

User Manual for Portable Sampler P6 L / P6 Mini MAXX



P6 L



P6 Mini MAXX

Access code for programming and settings

Password:

6299

Your Password:

Table of Contents

Section 1	SPECIFICATIONS	5
1.1	Dimension	6
Section 2	GENERAL INFORMATION.....	7
2.2	General Information	8
2.2.1	Areas of application.....	8
2.3	Product contents.....	9
Section 3	INSTALLATION.....	10
3.1.1	Required Tools	11
3.1.3	Installation location (P6 L and P6 MINI MAXX)	12
3.2	Electrical Connections	13
3.2.1	Electrical Installation	14
3.2.1.1	Prepare the electrical installation	14
3.2.1.2	Wiring diagram.....	15
3.2.1.3	Connection to a PC.....	16
3.3	Commission of the equipment.....	17
3.3.1	Switch on the device	17
3.3.1.	Tube connection and Positioning of the tubes	18
3.3.2	Set the individual sample volumes.....	19
3.3.2.1	Vacuum –dosing vessel	19
3.3.2.2	VAR Dosing vessel for flow-proportional sampling (Option).....	21
3.3.2.3	Peristaltic Pump.....	22
3.3.2.3	Calibration of the Peristaltic Pump	23
3.3.3	Remove the top part of the housing	24
3.3.5	Prepare the sample bottles.....	25
3.3.6	Attach the top part of the housing	26
3.3.7	Connect the equipment to the mains	27
Section 4	OPERATION.....	29
4.1	Control unit operation	29
4.1.1	Password.....	29
4.1.2	Programming.....	29
4.1.3	Keyboard layout/function	29
4.2	Normal operation	32
4.2.1	Replace the sample bottles	32
Section 5	MAINTENANCE AND CLEANING	34
5.1	Maintenance work.....	34
5.1.1	Desiccant replacement	34
5.2	Cleaning.....	39
5.2.1	Clean the housing and distribution unit.....	39

5.2.2 Clean the dosing vessel	40
5.3 Troubleshooting	42
5.3.1 Change the fuse	42
Section 6 REPLACEMENT PARTS AND ACCESSORIES.....	44
6.1 Spare parts - P6.....	44
6.1.1 Spare parts P6 Peristaltic Pump	44
6.1.1 Spare parts P6 Vacuum Dosingsystem	45
6.2 Accessories.....	47
Section 7 WARRANTY AND LIABILITY	49
List of Figures.....	50

Section 1 SPECIFICATIONS

TECHNICAL SPECIFICATION			
		P6 MINI MAXX	P6 L MAXX
Electric			
Power supply,			
	With integrated battery	12 V-7,5 Ah (DC)	
	With optional power pack	110–230 V/50–60 Hz.	
Rating		8 AT	
Power consumption		Peristaltic Pump: approx. 70VA / Vacuum System approx. 15VA	
Environment			
Medium temperature		0 to 40 °C [32 to 104 °F]	
Ambient temperature		0 to 50 °C [32 to 113 °F]	
Suction height		6,5 m [20 ft], optional < 8 m [26 ft]	
General specifications			
Maintenance requirements		Maintenance-free	
Weight			
	Top part		
	Bottle compartment		
	Complete	aprox. 9kg	aprox. 15kg
Dimensions (H X D) in mm			
	Top part	400 x 333	500 x 377
	Bottle compartment	400 x 310	500 x 415
	Complete	400 x 605	500 x 740
	With lid opened (90° / 110°)	90° 400 x 710 110° 400 x 685	90° 500 x 843 110° 500 x 819
Certification			
Certification		CE, sampling in accordance with ISO 5667-2/3-10	

These are subject to change without notice

1.1 Dimension

P6 L MAXX

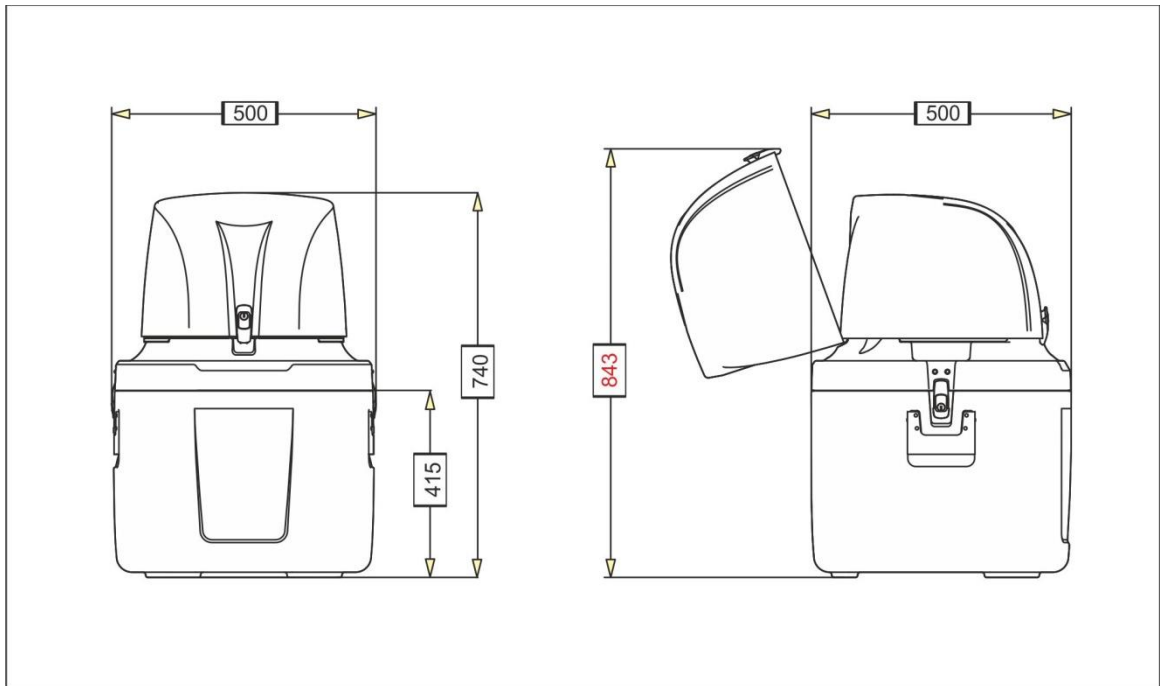

P6 MINI MAXX

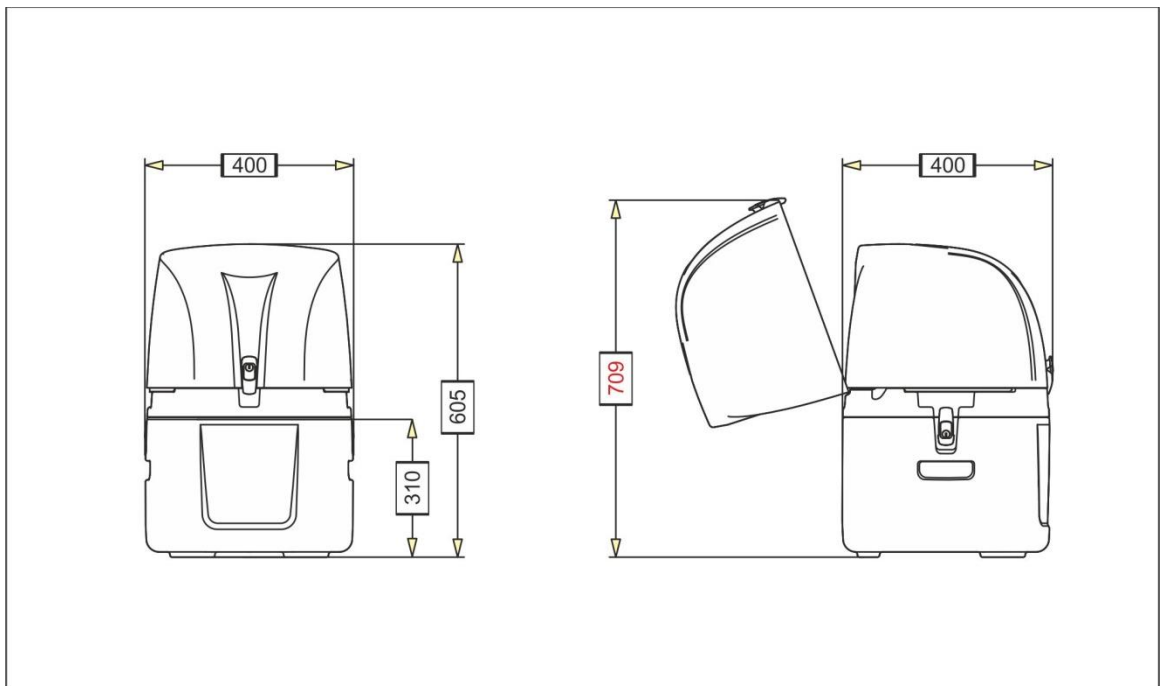

Figure 1 Dimension

Section 2 GENERAL INFORMATION

2.1 Safety information

Please read this entire manual before unpacking, setting up, or operating this equipment. Pay attention to all danger and caution statements. Failure to do so may result in personal injury or damage to the instrument.

To ensure that the protection provided by this equipment is not impaired, do not use or install this equipment in any manner other than that specified in this manual.

2.1.1 Use of hazard information



DANGER

Indicates a potentially or imminently hazardous situation which, if not avoided, will result in death or serious injury.



WARNING

Indicates a potentially or imminently hazardous situation that, if not avoided, could result in death or serious injury.



CAUTION

Indicates a potentially or imminently hazardous situation that could result in minor or moderate injury.

Important note: Information that requires special

emphasis. **Note:** Information that supplements



points in the main text.

2.1.2 Precautionary labels

Read all labels and tags attached to the instrument. Failure to do so may result in personal injury or damage to the instrument. A symbol, if noted on the instrument, will be included with a danger or caution statement in the manual.

	This symbol, if noted on the instrument, references the user manual for operation and/or safety information.
	This symbol, when noted on a product enclosure or barrier, indicates that a risk of electrical shock and/or electrocution exists.
	This symbol may appear on the product and indicates the need for protective eye wear.

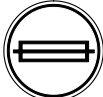
Specification

	This symbol may appear on the product and identifies the connection point for the protective ground.
	When this symbol appears on the product, it identifies the location of a fuse or a current limiter.
	Electrical equipment marked with this symbol may not be disposed of in European domestic or public disposal systems after 12 August 2005. In conformity with European local and national regulations (EU Directive 2002/96/EC), European electrical equipment users must now return old or end-of-life equipment to the manufacturer for disposal at no charge to the user Note: For return for recycling, please contact the equipment manufacturer or supplier for instructions on how to return end-of-life equipment, manufacturer-supplied electrical accessories, and all auxiliary items for proper disposal.

2.2 General Information

2.2.1 Areas of application

The equipment is used for sampling aqueous liquids with a temperature of 0 °C to 50 °C

(refer to [Section 1 Specifications, page 5](#)).

2.2.2 Functional description

The equipment provides temporary storage for liquids of a specified volume so that they can be analyzed.

2.3 Product contents

The equipment is supplied with a tube and brief operating instructions. The necessary charger is optional and available in IP20 or in IP 65.

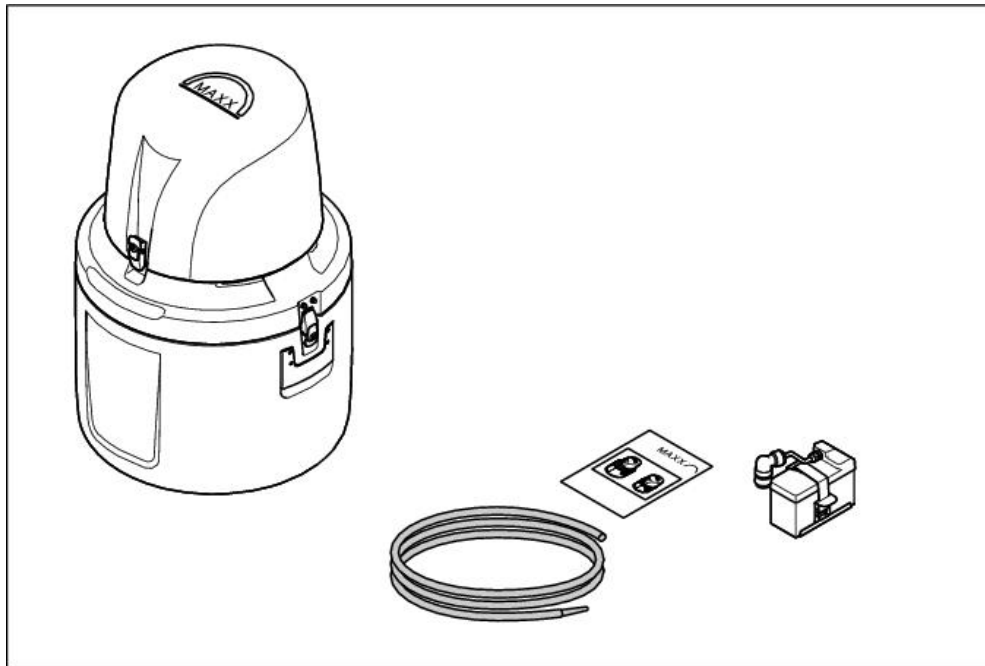

Figure 2 Scope of delivery (P6 L MAXX)

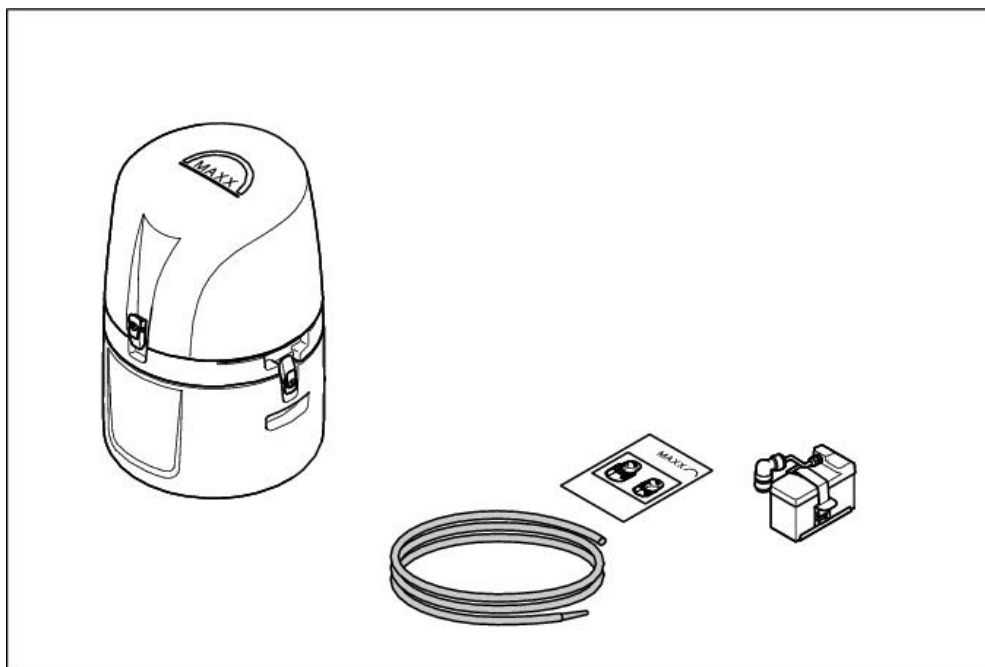

Figure 3 Scope of delivery (P6 MINI MAXX)

Section 3 INSTALLATION



DANGER

Only qualified experts should conduct the tasks described in this section.



DANGER

Select an appropriate installation location for the instrument.

Plan out the mechanical mount, before positioning poles or drilling holes. Make sure the mount has a sufficient bearing capacity. The dowels must be selected and authorized according to the condition of the wall. The manufacturer shall accept no liability if the instrument is installed incorrectly.

Plan how to lay cables and tubes and their path in advance. Lay the tubes, data cables and power cables without any bends and so they do not pose a tripping risk.

Do not connect the electrical supply to the mains if the equipment has not been wired and fused correctly.

Sufficiently protect the electrical power supply against short circuits.

For the external power supply, always connect a residual-current circuit breaker (trip current max.: 30 mA) between the mains and the system.

If the equipment is to be installed outdoors, switch the overload protection between mains and system.

Products intended by the manufacturer for outdoor use offer a higher level of protection against the penetration of liquids and dust. If these products are connected to a mains outlet with a cable and plug rather than a permanently connected cable, the plug and outlet are much more susceptible to liquid and dust penetration. The operator must sufficiently protect the plug and outlet against liquid and dust penetration in accordance with local safety regulations. If the instrument is to be used outdoors, it must be connected to a suitable outlet with a protection type of at least IP44 (splash protection).

3.1 Mechanical Installation

**DANGER**

Select an appropriate installation location for the instrument. Plan out the mechanical mount before positioning poles or drilling holes. Make sure the mount has a sufficient bearing capacity. The dowels must be selected and authorized according to the condition of the wall. The manufacturer shall accept no liability if the instrument is installed incorrectly. Plan how to lay cables and tubes and their path in advance. Lay the tubes, data cables and power cables without any bends and so they do not pose a tripping risk.

Note : For information on installation with optional accessories, refer to the relevant installation instructions.

3.1.1 Required Tools

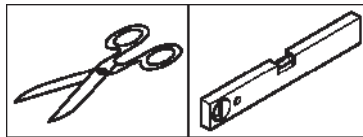

Figure 4 Required tools (P6 L and P6 MINI MAXX)

3.1.3 Installation location (P6 L and P6 MINI MAXX)

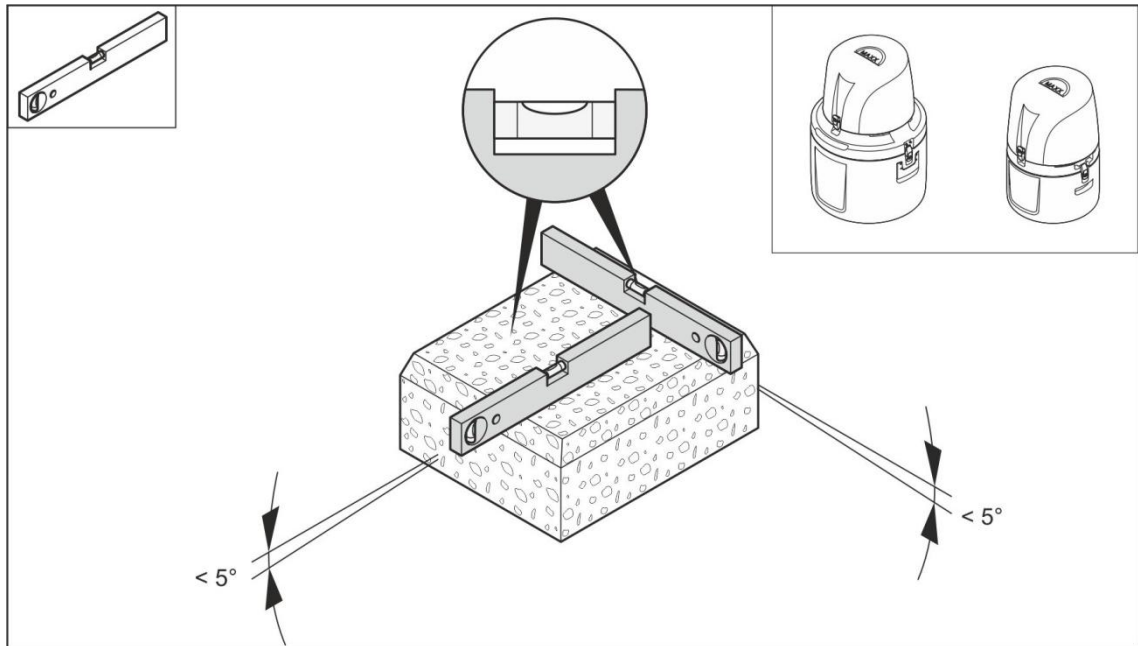

Figure 5 Select installation location (P6 L and P6 MINI MAXX)

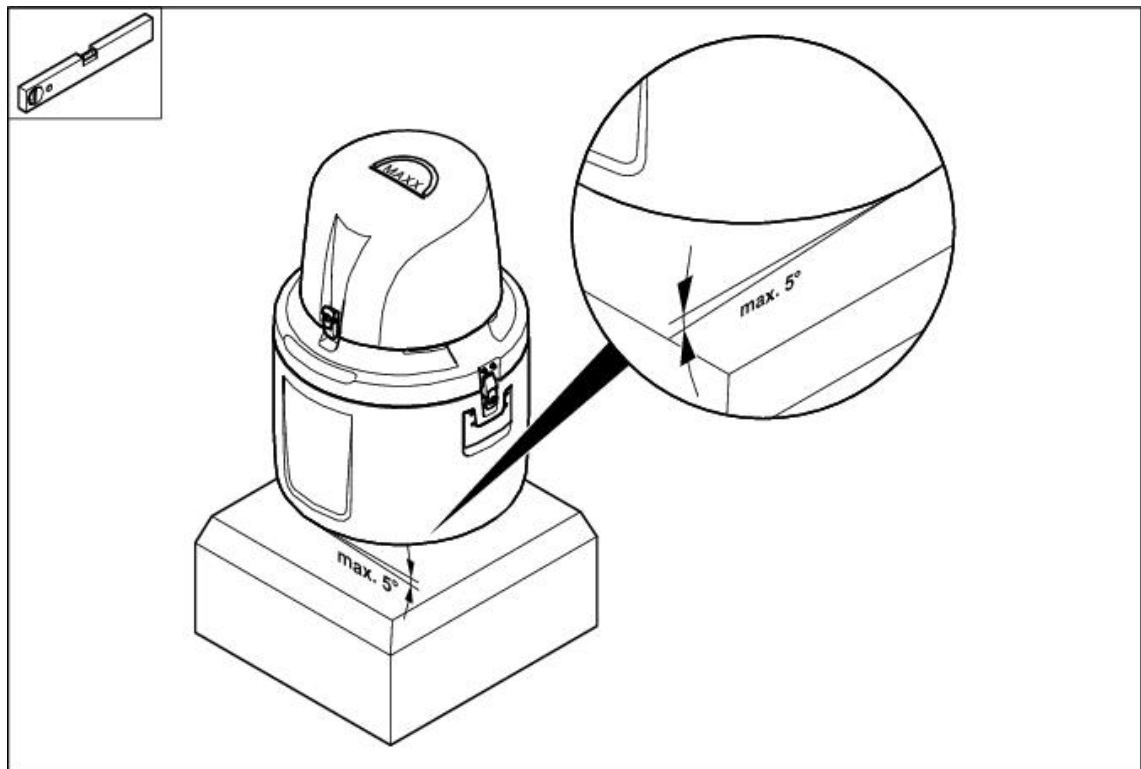

Figure 6 Position the equipment (P6 L and P6 MINI MAXX)

3.2 Electrical Connections

**DANGER**

Only qualified experts should conduct the tasks described in this section.

**DANGER**

Do not connect the electrical supply to the mains if the equipment has not been wired and fused correctly.

Sufficiently protect the electrical power supply against short circuits.

For the external power supply, always connect a residual-current circuit breaker (trip current max.: 30 mA) between the mains and the system.

If the equipment is to be installed outdoors, switch the overload protection between mains and system.

If the mains plug of the power supply cable is removed, a suitable double-pole one-way switch must be installed immediately next to the display unit with clear labeling for the power supply.

Products intended by the manufacturer for outdoor use offer a higher level of protection against the penetration of liquids and dust. If these products are connected to a mains socket with a cable and plug rather than a permanently connected cable, the plug and socket are much more susceptible to liquid and dust penetration. The operator must sufficiently protect the plug and outlet against liquid and dust penetration in accordance with local safety regulations. If the instrument is to be used outdoors, it must be connected to a suitable outlet with a protection type of at least IP44 (splash protection)

3.2.1 Electrical Installation

3.2.1.1 Prepare the electrical installation



Charging the storage battery

The integral battery is a maintenance-free sealed lead-acid battery.

Charge the storage battery for **at least 14 -16 hours** prior to the first use.

This charging time is also necessary if the storage battery is empty. To avoid a total discharge, a protective mechanism is built-in which automatically switches off the device when the voltage is too low.

The storage battery cannot be overcharged as the battery charger switches to compensation charge as soon as the battery is fully charged.

For longer periods of non-use, top up the charge regularly (connect the battery to the charger).

In any case, avoid a total discharge as otherwise the storage battery will be damaged

	In battery mode	In mains power mode
P6 L	Charge battery	Connect the Y cable as shown in Figure 7.and 8
P6 MINI MAXX	Charge battery	Connect the Y cable as shown in Figure 7 and 8.

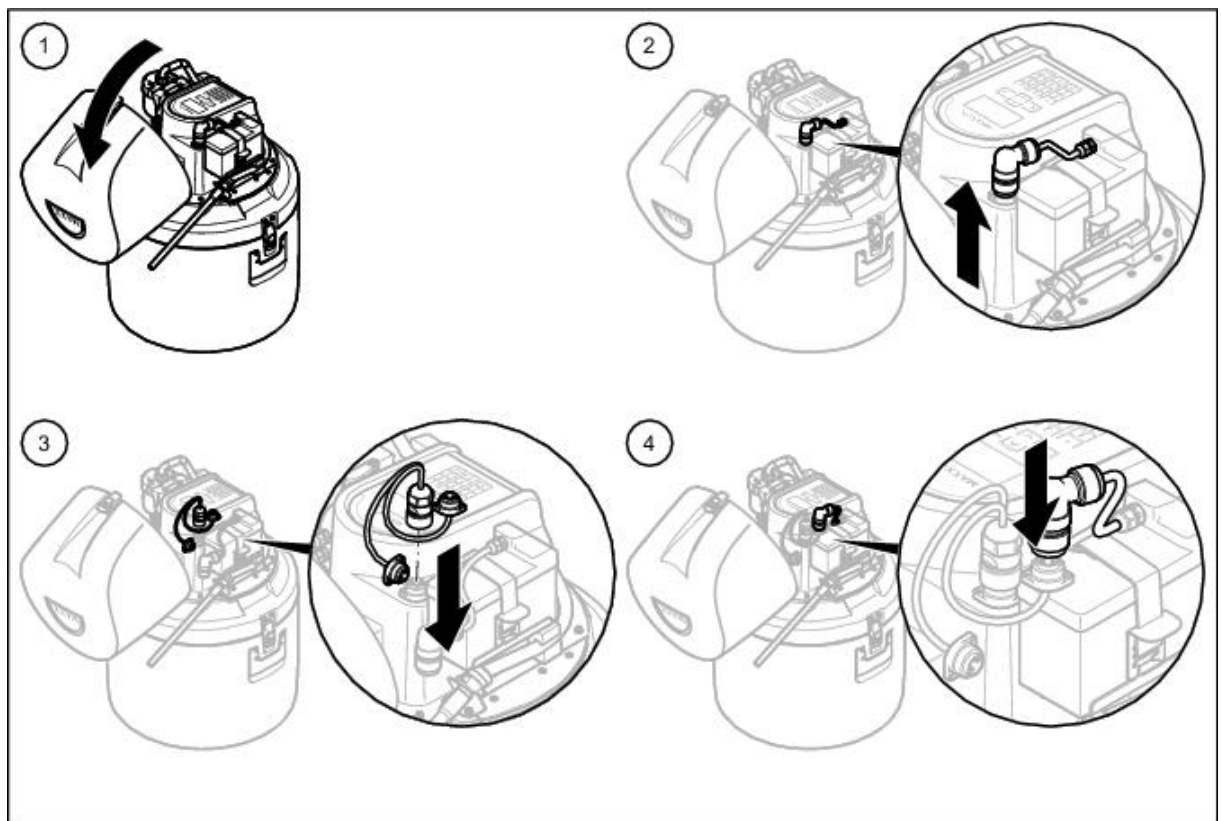

Figure 7 connect the Y-cabel

To connect the equipment to the mains, connect the Y-cable with the charger see Figure. 8

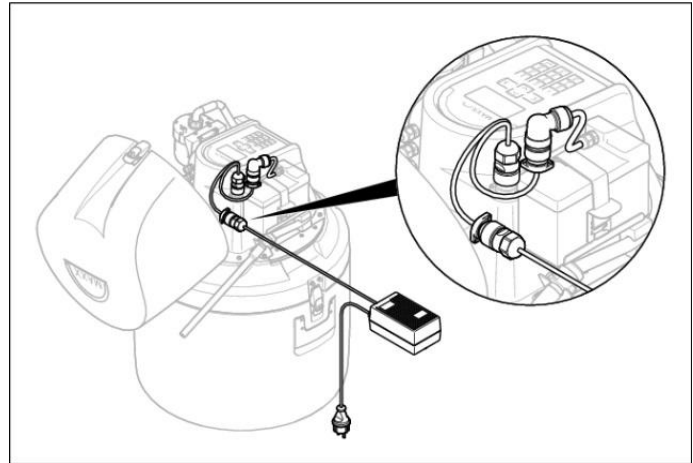

Figure 8 connect the Y-cabel with the charger

3.2.1.2 Wiring diagram

Please note:

- The assignment of the connections in the illustration below
- The cable color of the label on the cable.

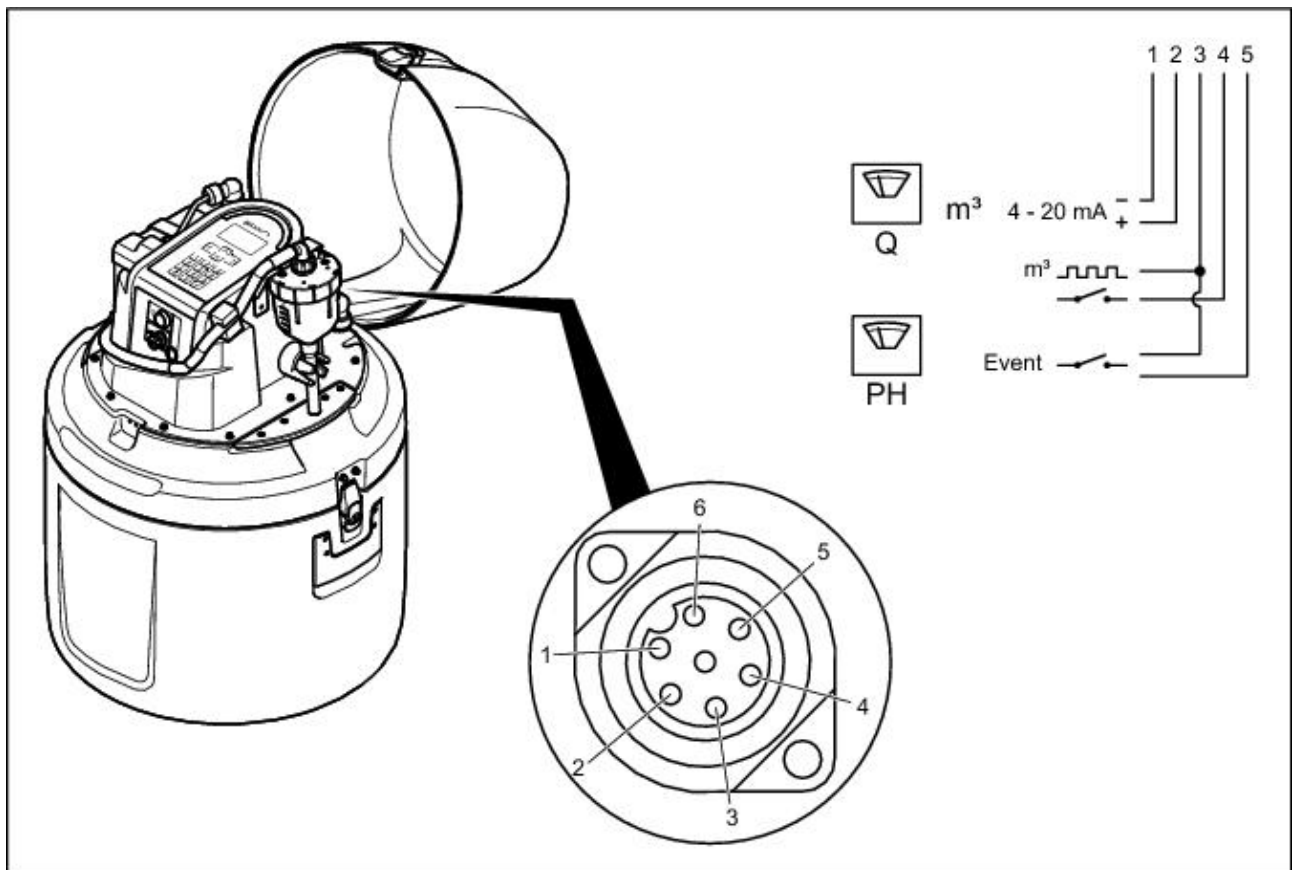

Figure 9 Connection plan for the optional signal cable (0069644)

3.2.1.3 Connection to a PC

The sampler is connected to a PC by means of an 3 m. MiniUSB interface cable (art. No. 0069793)
With the software “maxxware-Connect” it’s possible to read out the data to a PC.
As option is a LAN/WLAN/GPRS-UMTS board for remote communication also available.

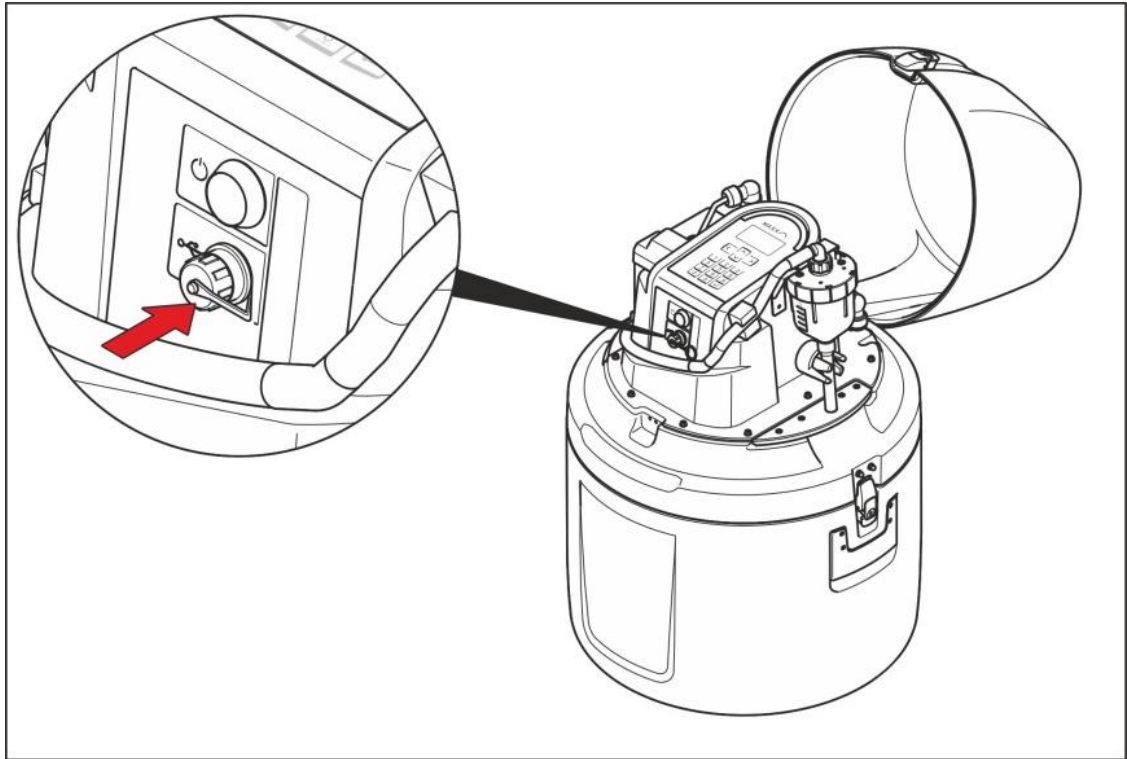

Figure 10 Connection to a PC

3.3 Commission of the equipment

3.3.1 Switch on the device

The device is switched on and off by the ON / OFF switch

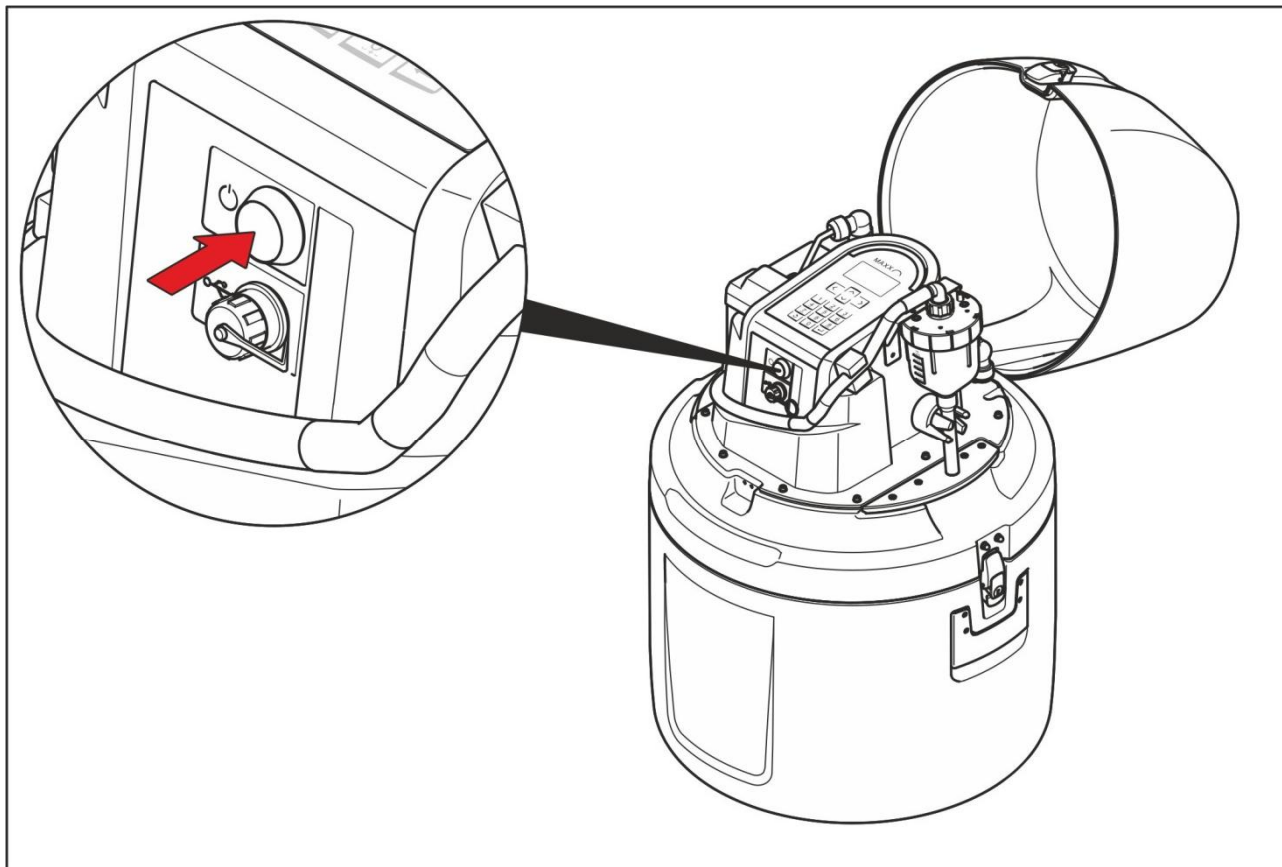

Figure 11 Switch-on and off

3.3.1. Tube connection and Positioning of the tubes

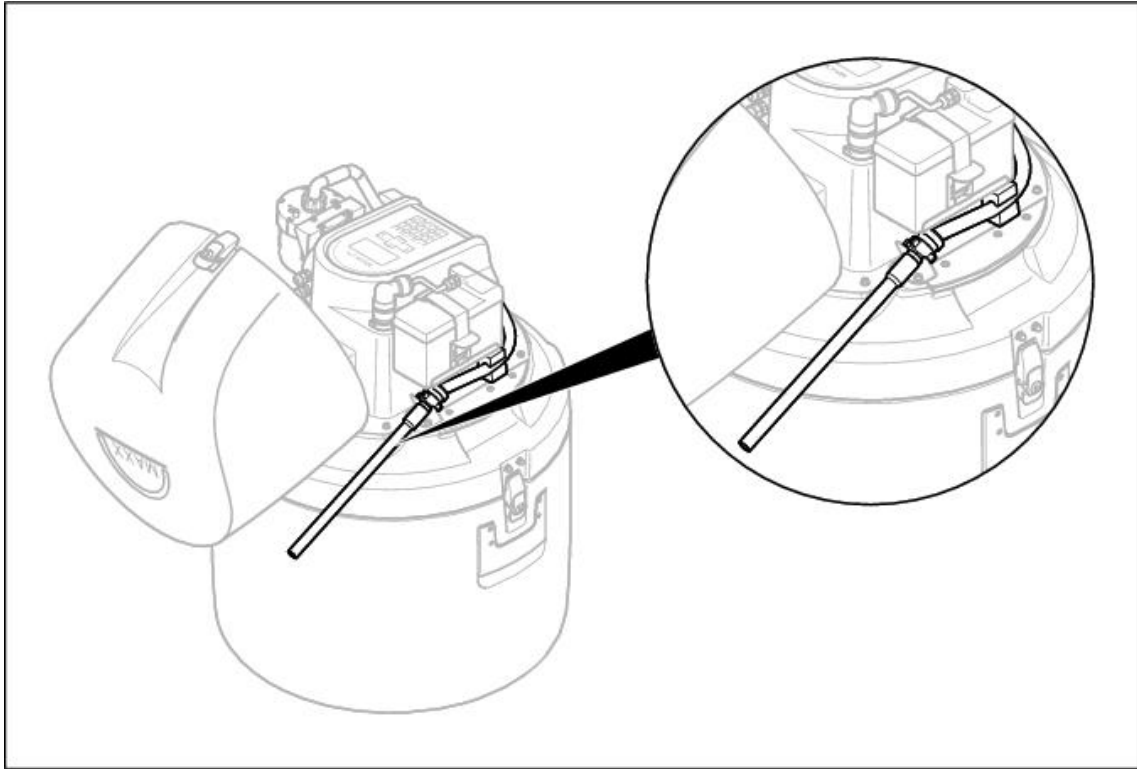

Figure 12 Connect the Intake tube

Positioning of the tubes according to the following installation diagram

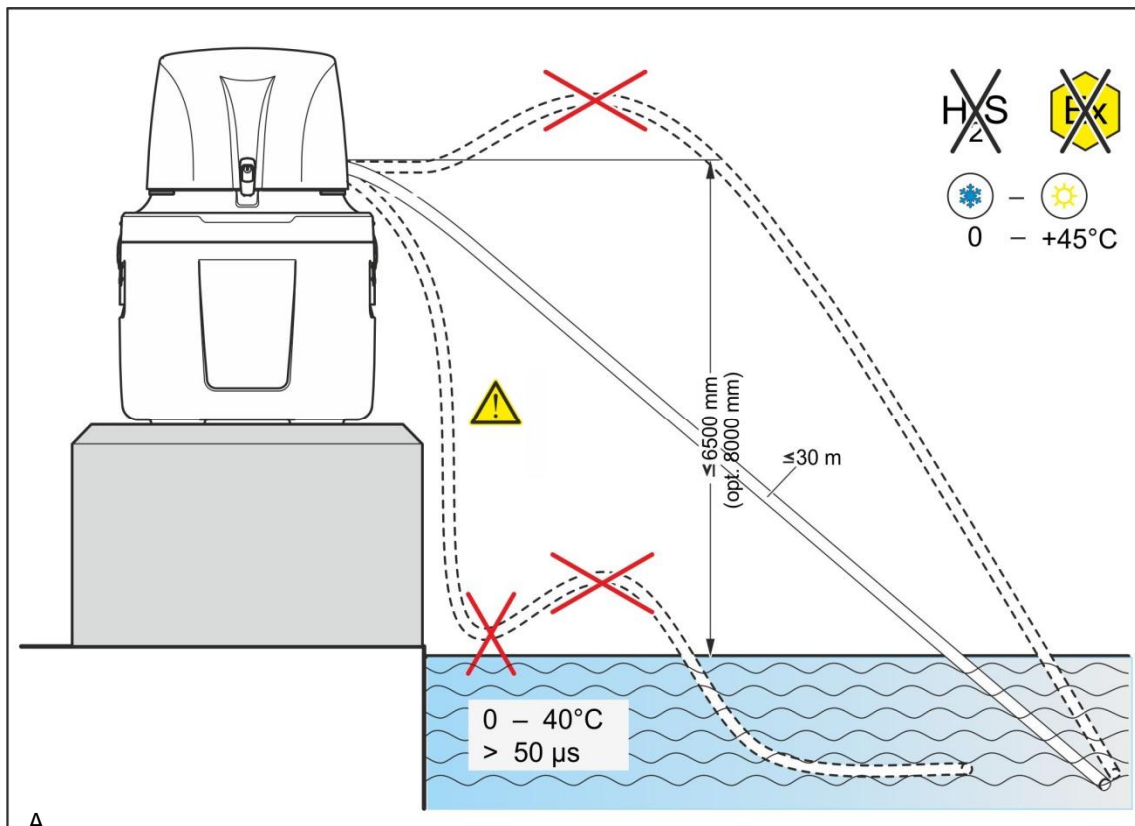

Figure 13 Installation diagram

3.3.2 Set the individual sample volumes

3.3.2.1 Vacuum –dosing vessel

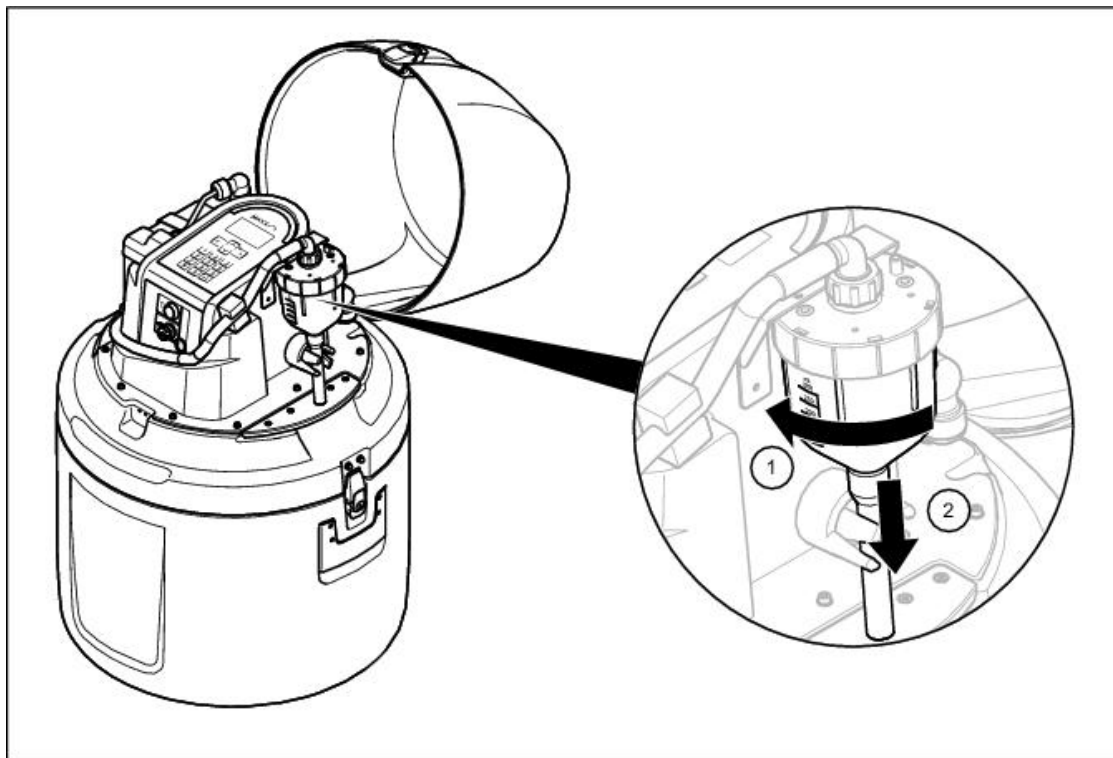

Figure 14 Unlock the bayonet cap on the plastic dosing vessel

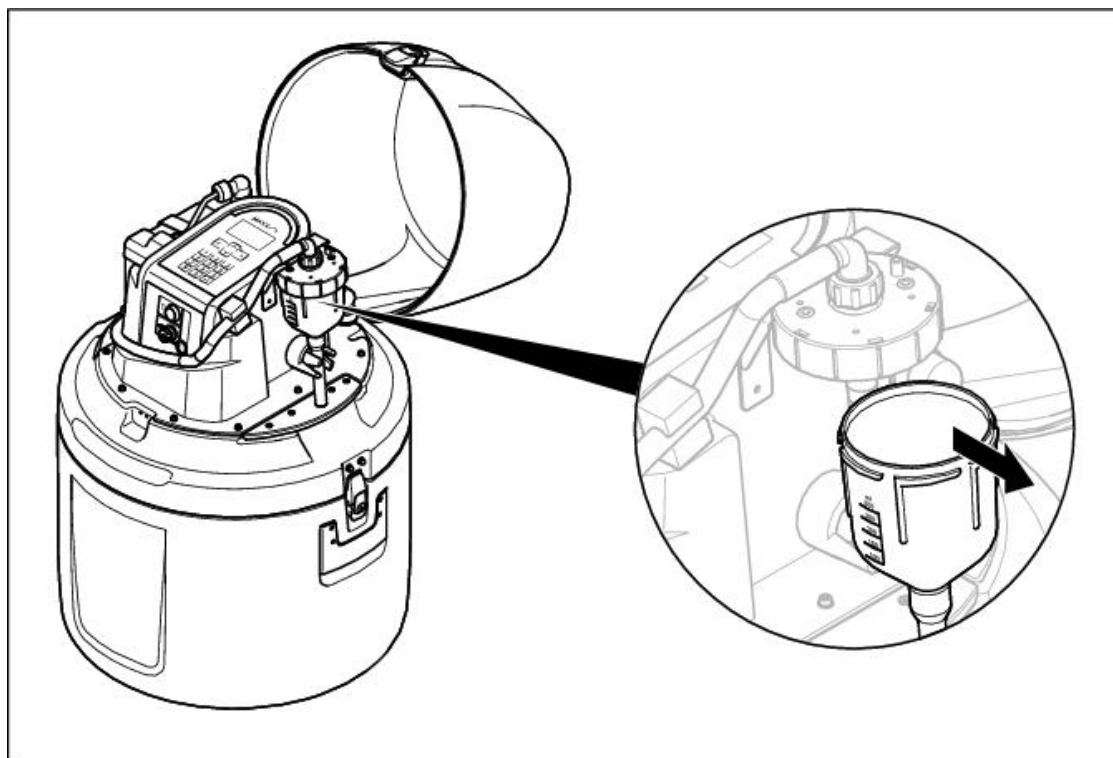

Figure 15 Remove the plastic dosing vessel

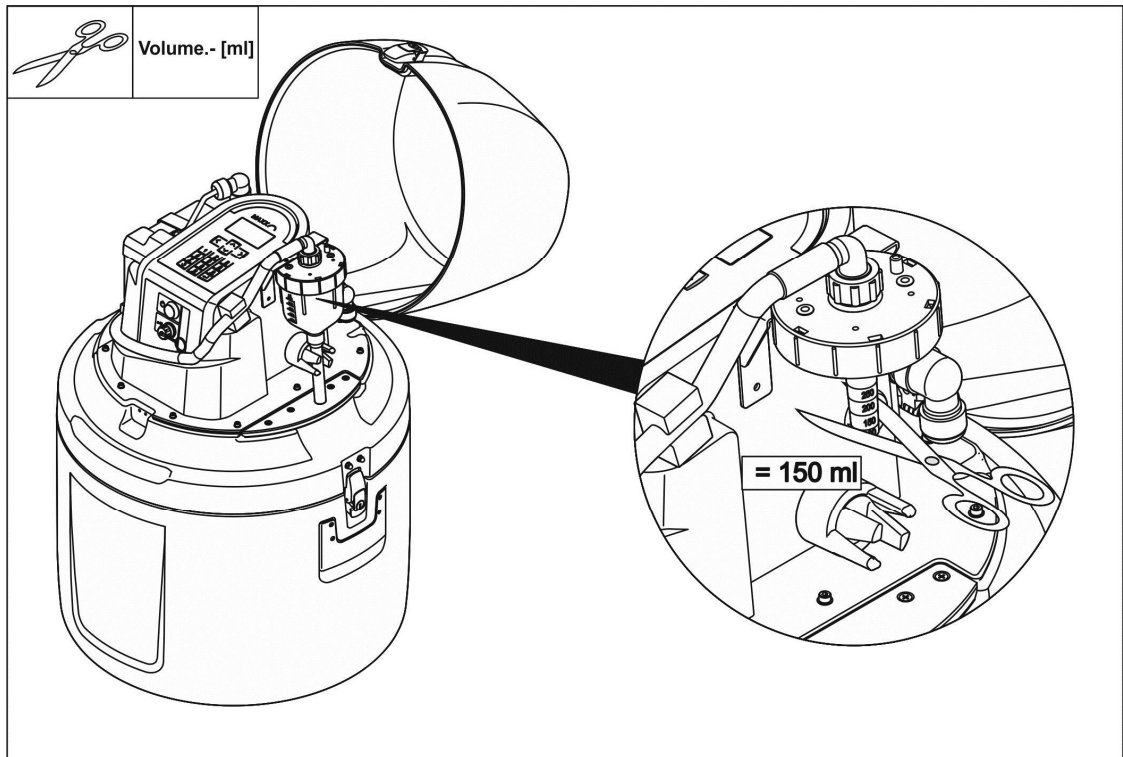

Figure 16 Cut the dosing tube to set the sample volume

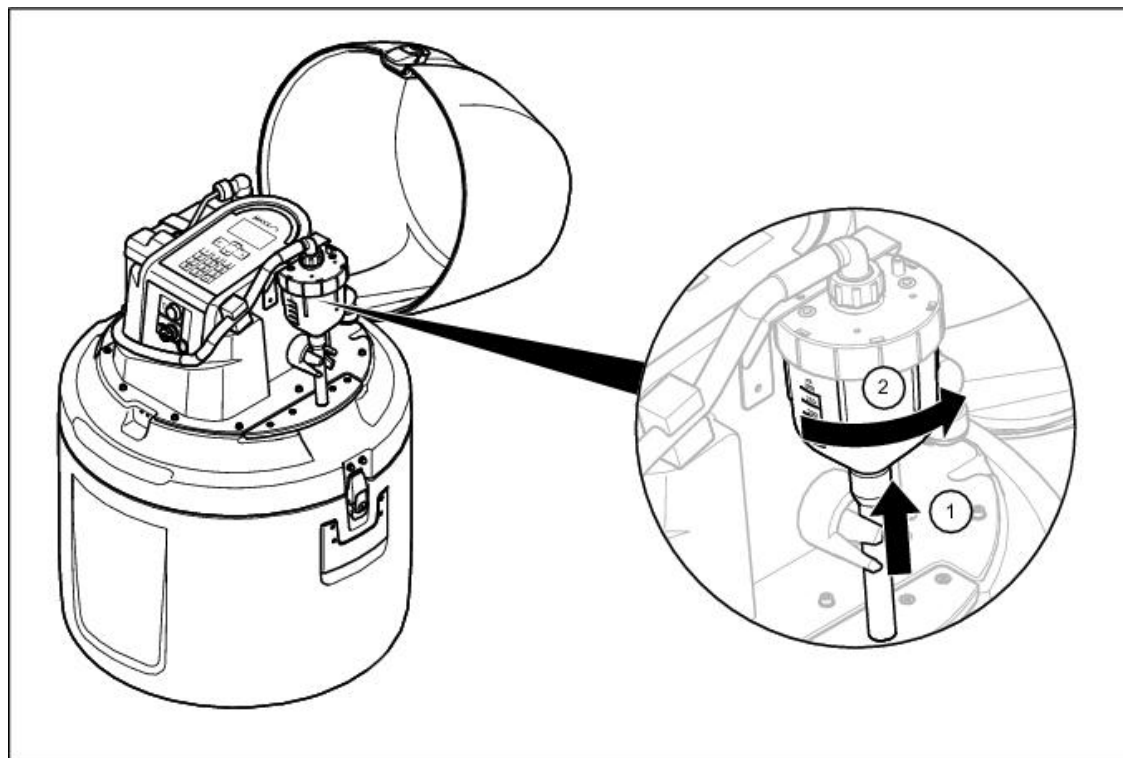

Figure 17 Assemble the plastic dosing vessel

3.3.2.2 VAR Dosing vessel for flow-proportional sampling (Option)

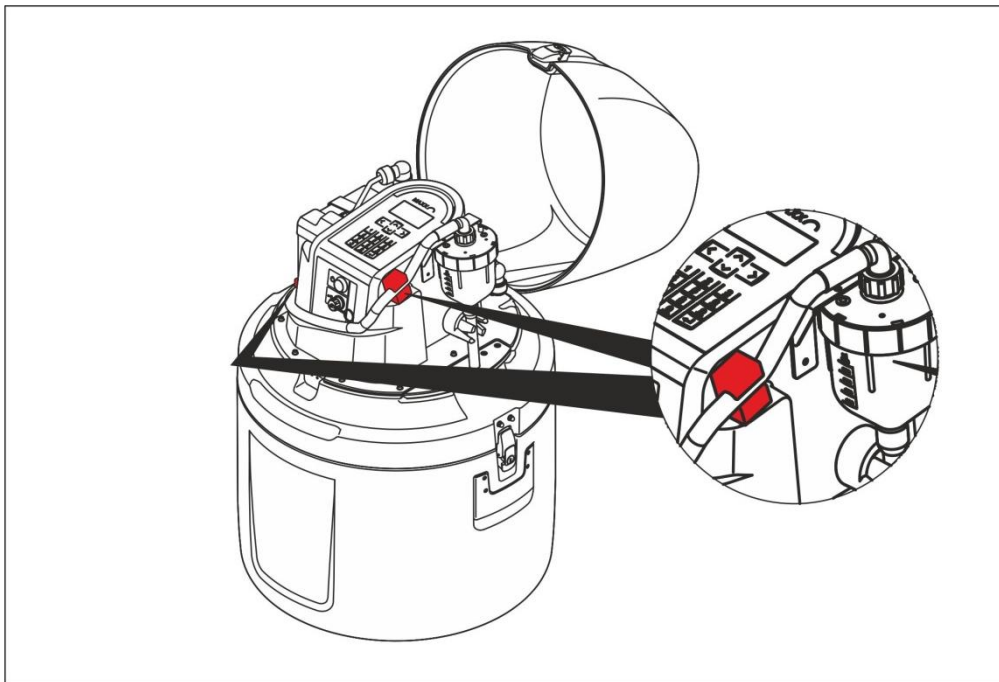
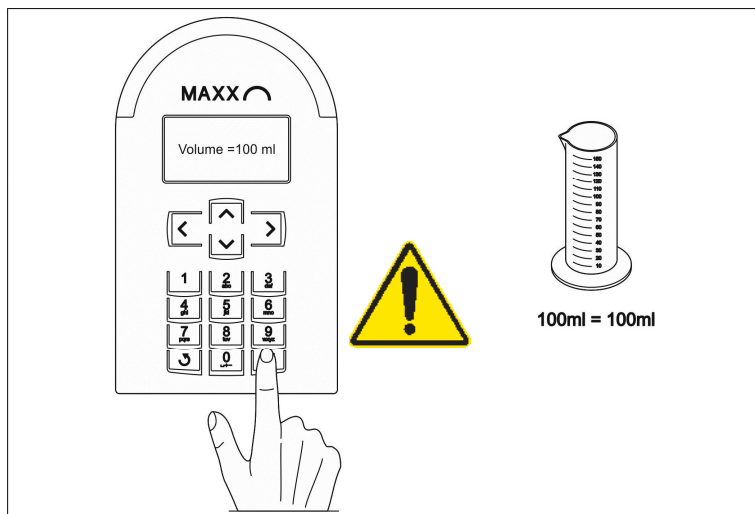

Figure 18 Unit with the VAR Sensors (optional)



Note: The accuracy is only guaranteed if the system was previously calibrated for the sampling site (see Programming Manual -> "calibration")

$$\Delta P = 0 \text{ hPa/bar}$$

The flow-proportional dosing vessel (VAR) can only be used, if there is **NO counter pressure!**

Figure 19 Calibrate the flow-proportional dosing vessel in the "Settings" Menu

With the VAR Dosing vessel, the sample volume is adjusted via keypad

3.3.2.3 Peristaltic Pump

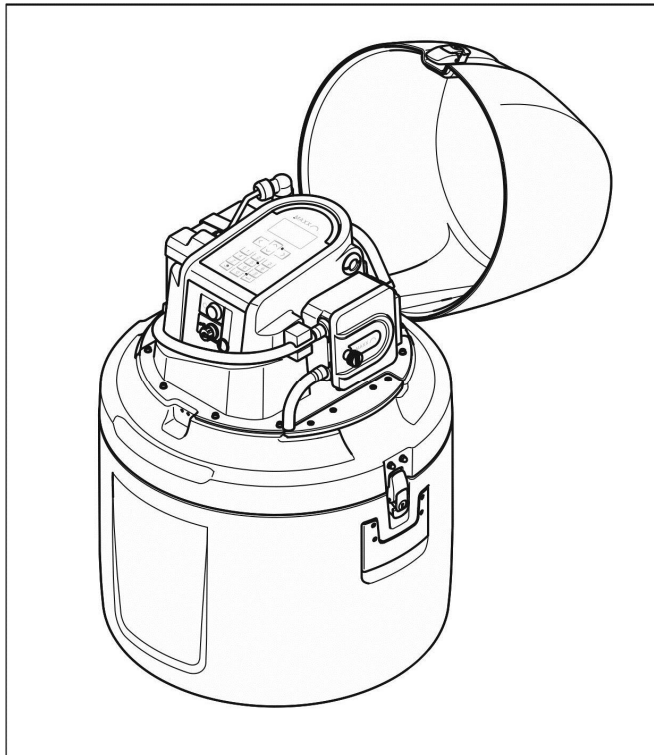

Figure 20 Unit with Peristaltic Pump

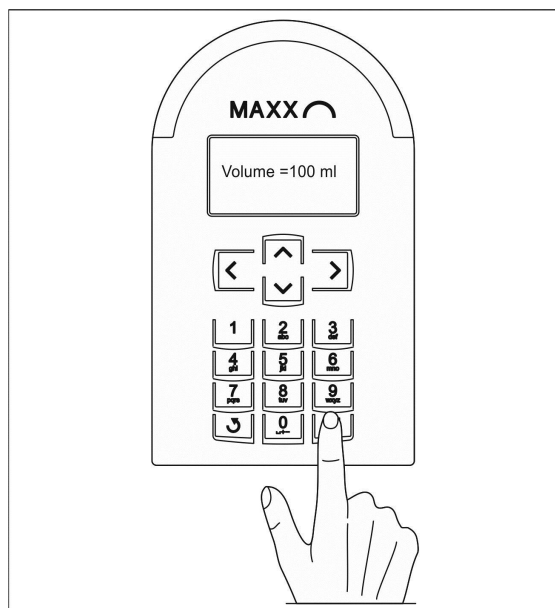

Figure 21 Set of the sample volume

With the Peristaltic Pump the sample volume is adjusted via keypad

3.3.2.3 Calibration of the Peristaltic Pump

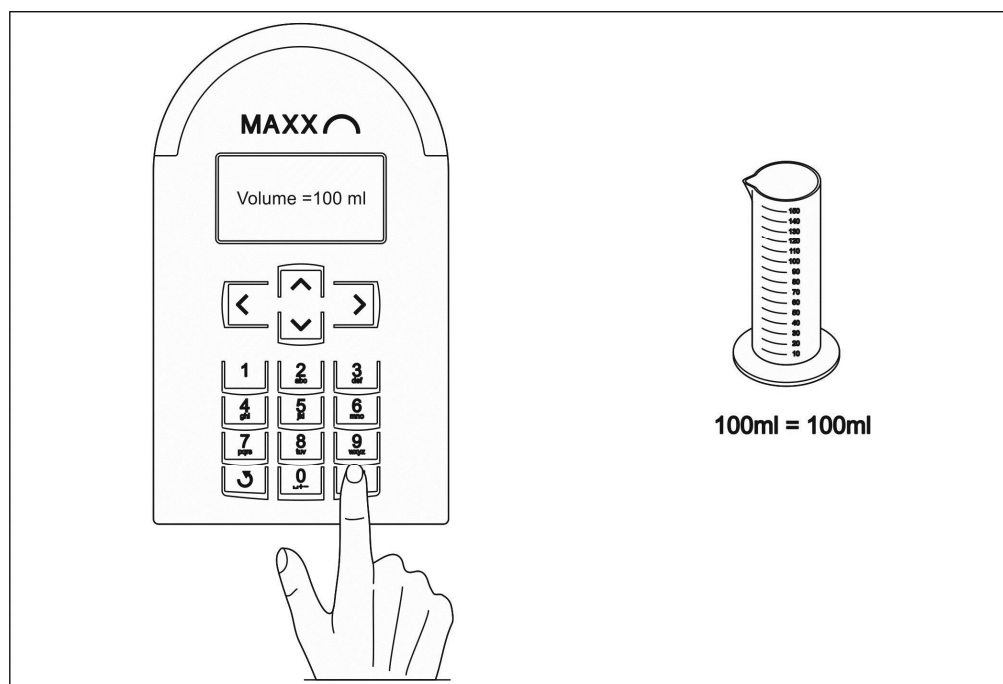

Figure 22 Calibrate the Peristaltic Pump for flow-proportional sampling

Note: The accuracy is only guaranteed if the system was previously calibrated for the sampling site (see **Programming Manual** -> "Settings" "calibration")

3.3.3 Remove the top part of the housing

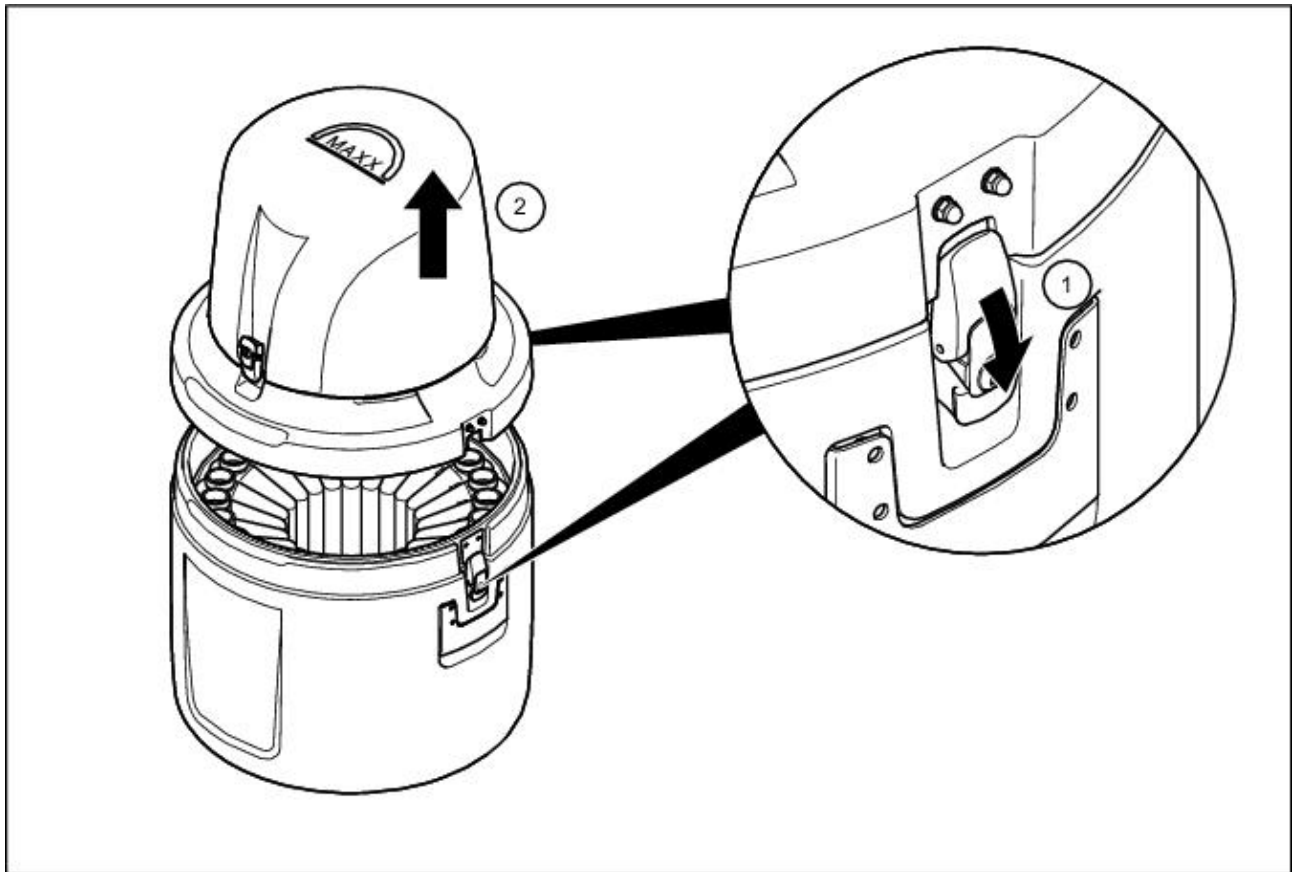

Figure 23 Remove the top part of the housing

3.3.5 Prepare the sample bottles

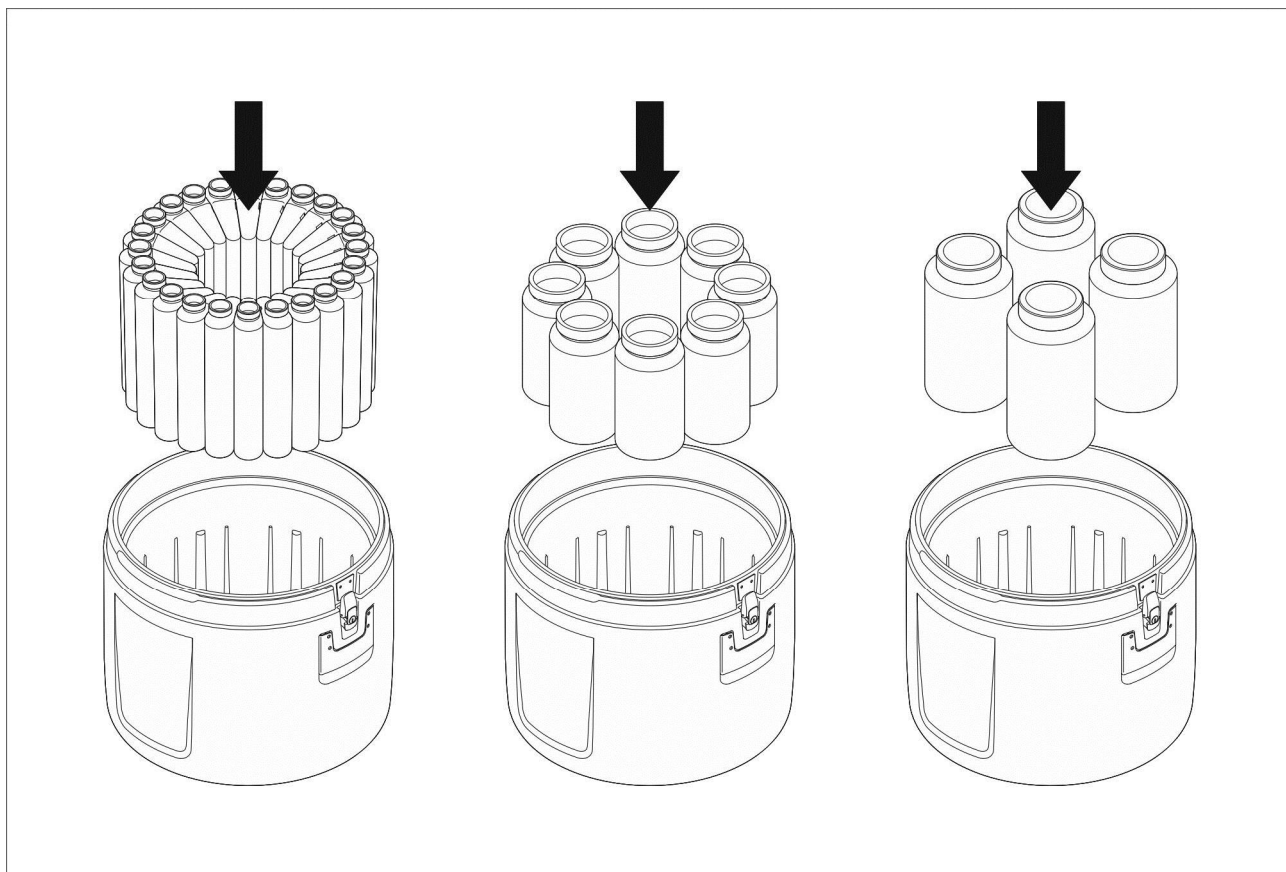

Figure 24 Place the empty bottles into the bottle compartment

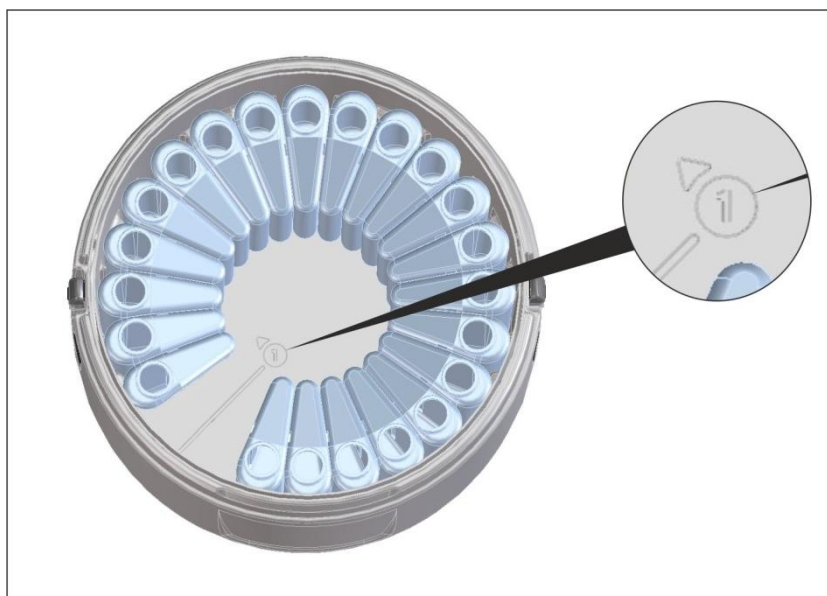

Figure 25 Position for bottle No. 1

Note:

At the bottom of the lower part is the position for bottle No. 1 marked together with the filling direction, thus you can assign the bottles with the sample cycle.

3.3.6 Attach the top part of the housing

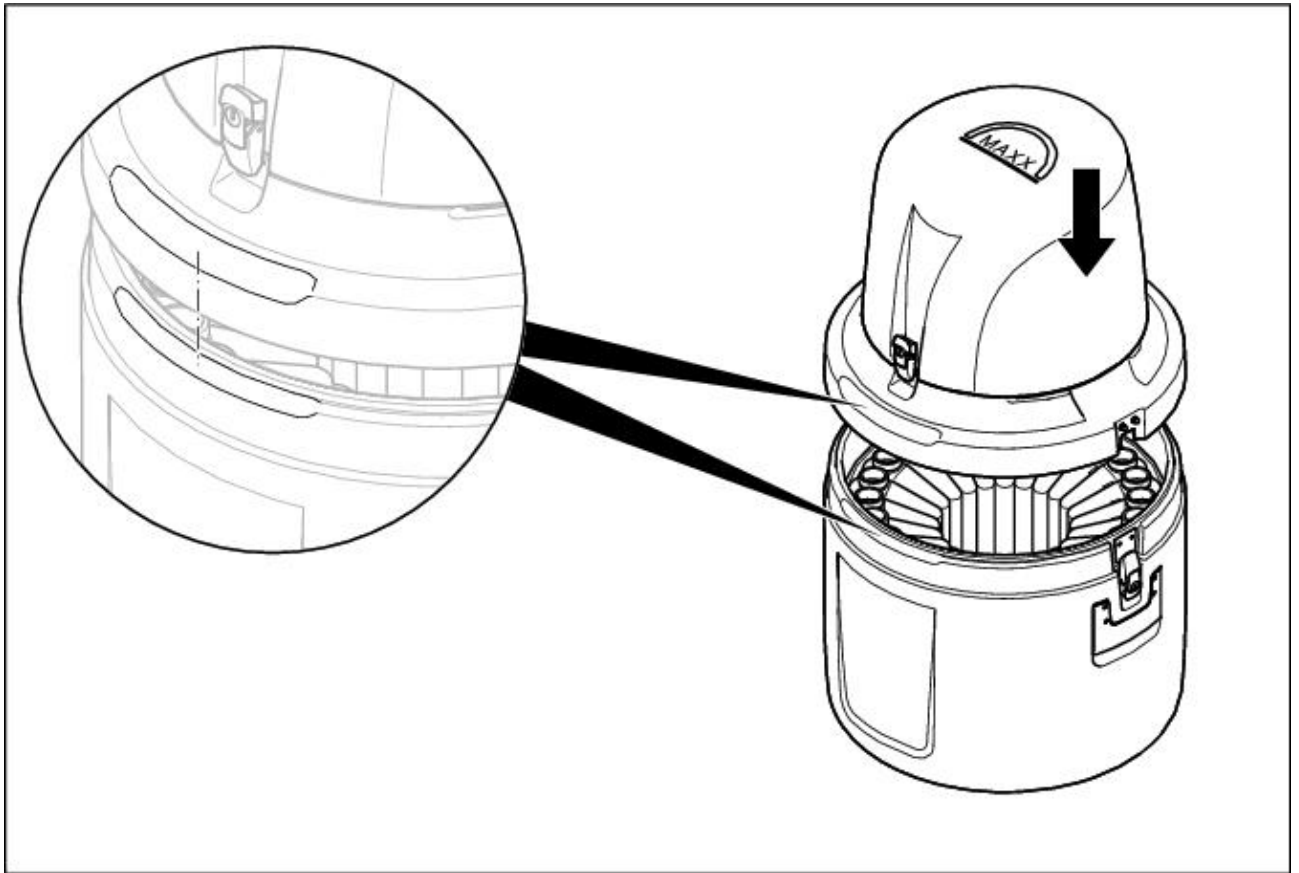

Figure 26 Attach the top part of the housing

3.3.7 Connect the equipment to the mains

Make sure that,

- The equipment has been fully prepared for commissioning,
- The data on the type plate corresponds to the data relating to the mains power supply (P6 L and P6 MINI MAXX in in connection with the charger and Y -plug 0069742),
- The correct plug has been attached or the direct wire has been implemented correctly
- The equipment can be put into operation without any risks

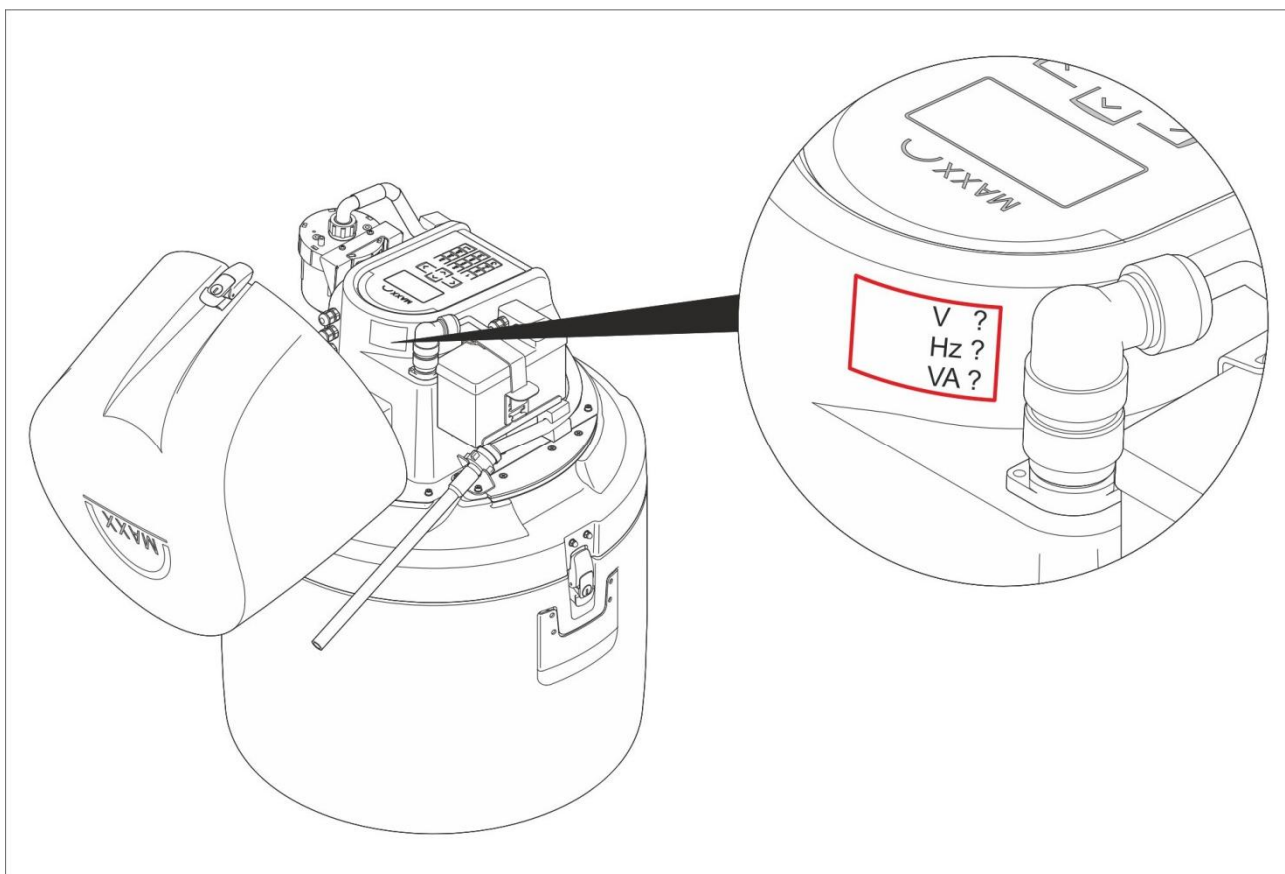

Figure 27 Rating label

Installation

Mains powered float charge option

The integral storage battery can be charged by means of the mains powered battery charger. In case of a higher energy demand, the battery charger can be permanently connected to the mains, so that the integral storage battery of the sampler is left permanently on charge (float charge).

Connect the charger with the Y-cable as shown in Figure 27

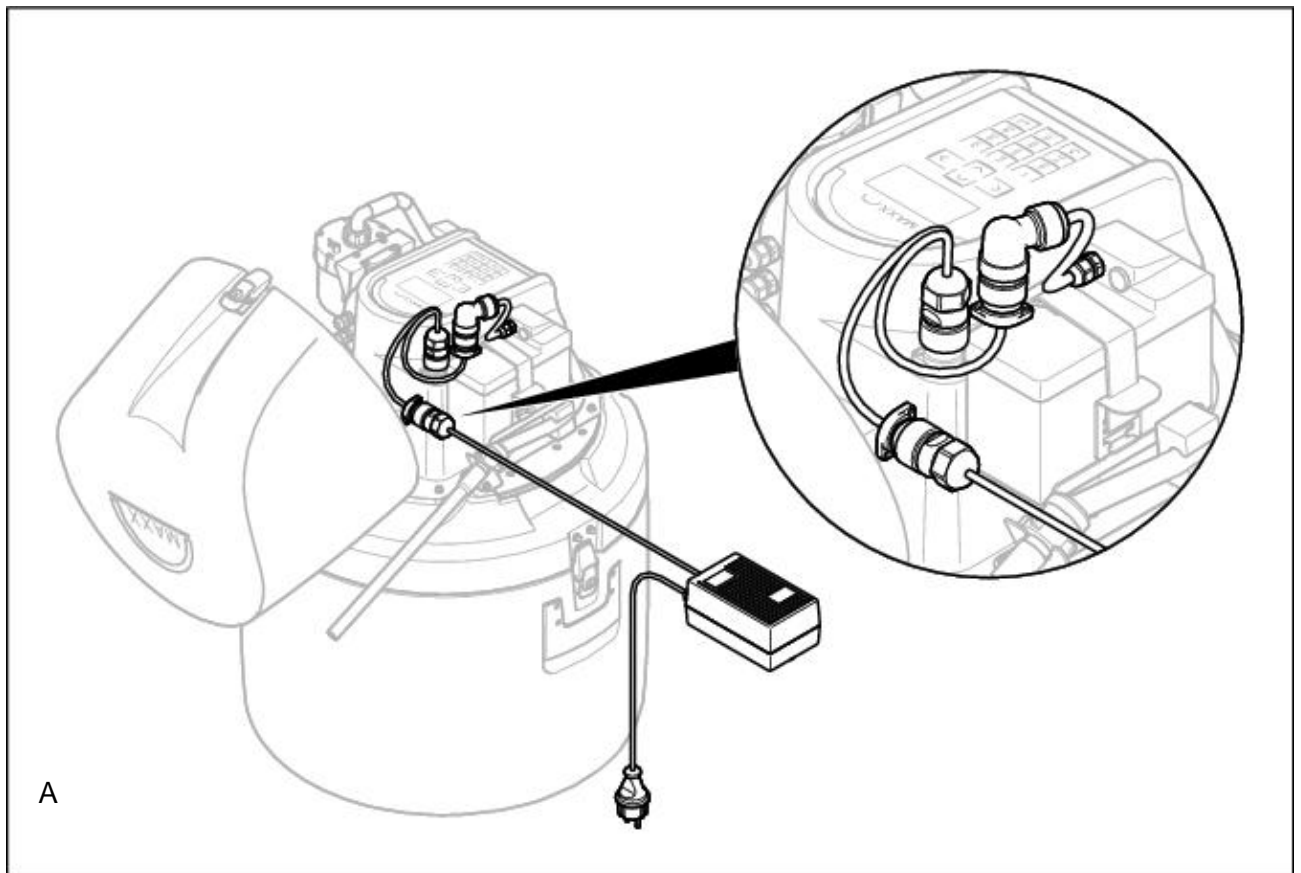

Figure 28 Connect the charger with the Y-cable



DANGER

Make sure that the power supply, cable (also refer to [Figure 27](#), [page 27](#)) and equipment are suitable for use with each other..

Section 4 OPERATION

4.1 Control unit operation

All the equipment functions are software-controlled.
See the detailed description in the Programming Manual“

4.1.1 Password

Default Password to program sampler and to change settings is

6299

4.1.2 Programming

The menu structure resembles the directory structure of a computer hard drive and is divided into main menus and sub menus.

4.1.3 Keyboard layout/function

The equipment can be programmed by the operator

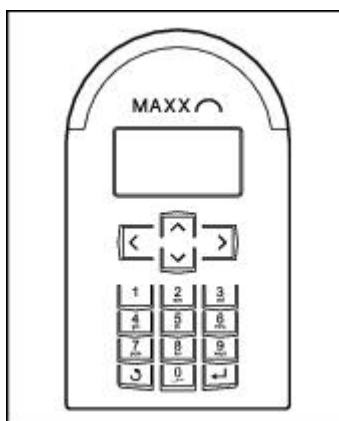





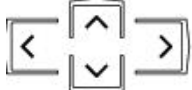





Figure 29 Control panel

The key functions are configured as follows to enable highly intuitive operation:

Table 1 Key functions

Display help text (in the case of selection fields, the cursor must be placed on the left-hand side)	Arrow- key	
Move from one menu item to the next menu selection	Arrow- key	
Select the desired menu	Enter-key	
Move within a menu	Arrow- key	
Select from within a menu	Arrow- key	
Confirm the selection (automatically marked with a ✓)	Enter-key	
Enter/change values	Arrow- key	
Confirm the entered values	Enter- key	
Return to the next superordinate menu level	Back- key	
Enter values	Numeric keypad	
Initialise (Reset) of Display - Press together	Back-key + Enter	Gemeinsam drücken
Wakeup sleep mode (press 5 sec. at least)	Back- key	Press 5 sec. at least
Restore factory settings (Display = „load factorysettings“) Hold Back-key until boot process is finished NOTE: All data will be deleted	Back- key	

Example: A setting needs to be changed.

1. Use the arrow keys to move the cursor until it is in the required position.
2. PRESS the ENTER-key

The selection is now confirmed and the program can be started

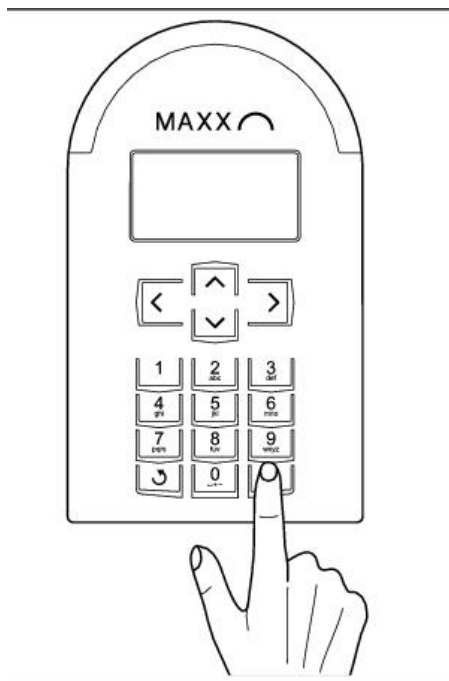

Figure 30 Start the program

Depending on the program range,

- an activity is started or
- the next menu item is automatically selected..

Note: *The general rule:*

If you press Back,

- *the activity is cancelled or*
- *the navigation takes one step back in the menu*

4.2 Normal operation

4.2.1 Replace the sample bottles

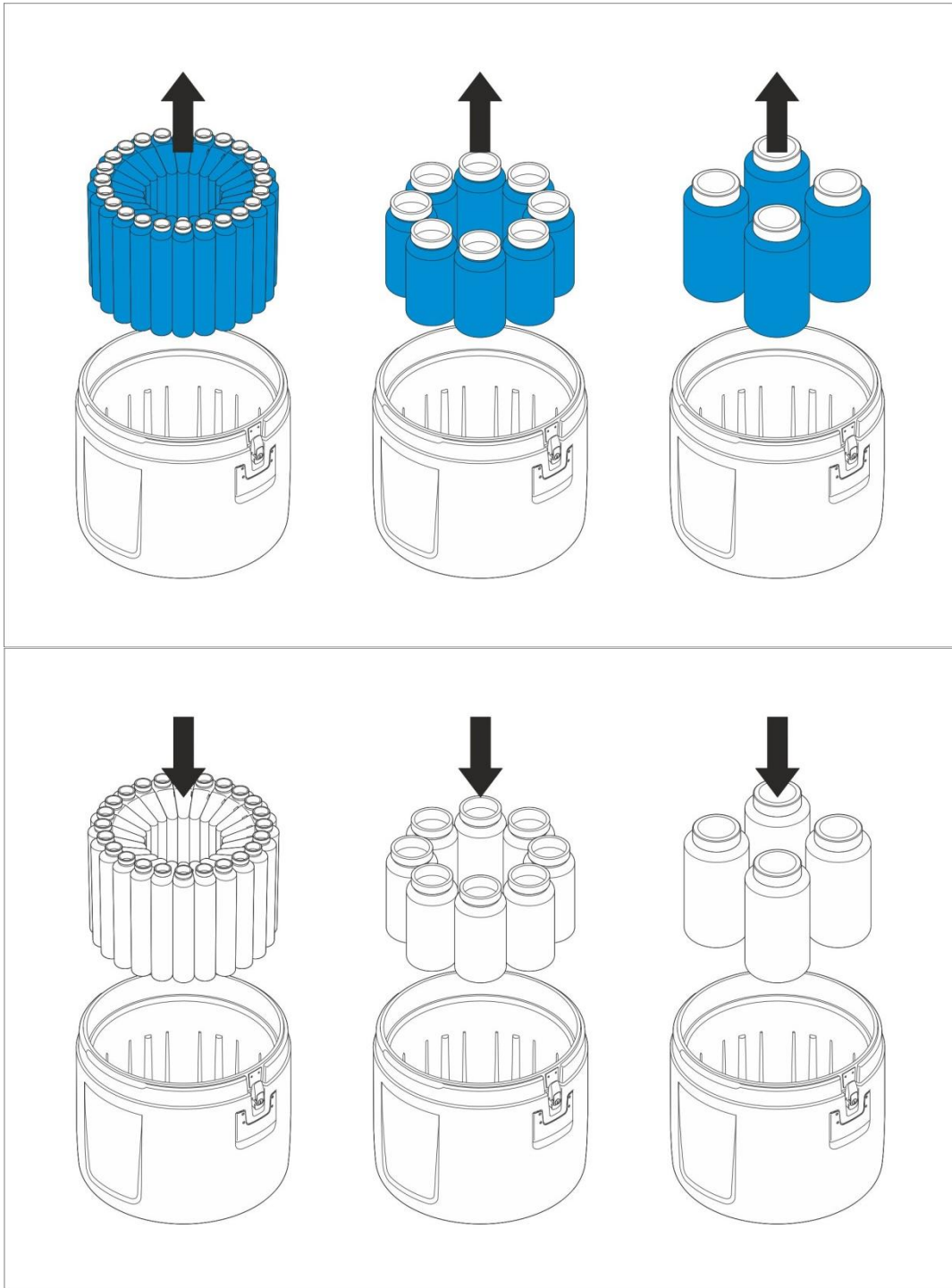

Figure 31 Replace full bottles

Section 5 MAINTENANCE AND CLEANING



DANGER

Only qualified experts should conduct the tasks described in this section.



WARNING

Please observe the following points for the use of chemicals and/or waste water:

Wear protective clothing: –

- *Laboratory coat*
- *Protective eyewear*
- *Rubber gloves*

5.1 Maintenance work

5.1.1 Desiccant replacement

A desiccant cartridge (40 % rel. humidity) is located inside the controller to absorb moisture and prevent corrosion . Over time the desiccant will become saturated with moisture and should be replaced. Monitor the desiccant color through the clear plastic window . The color will change from **blue to pink** when the desiccant is saturated

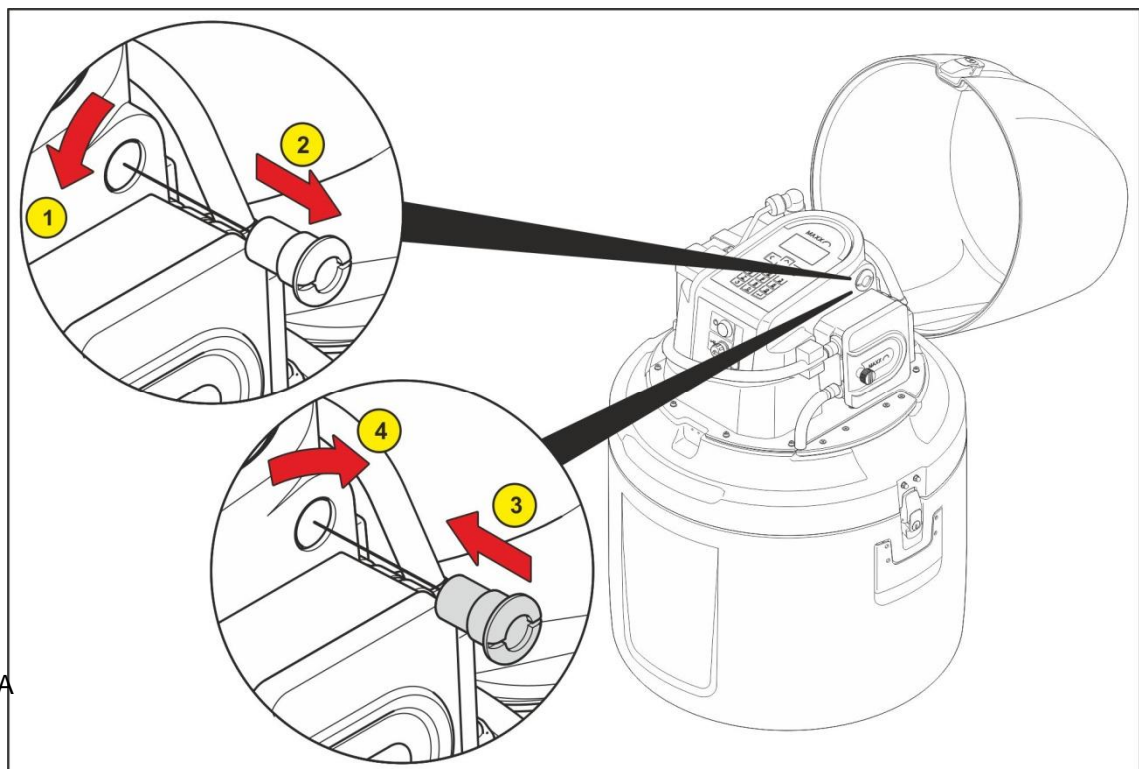

Figure 32 Desiccant replacement–Peristaltic Pump

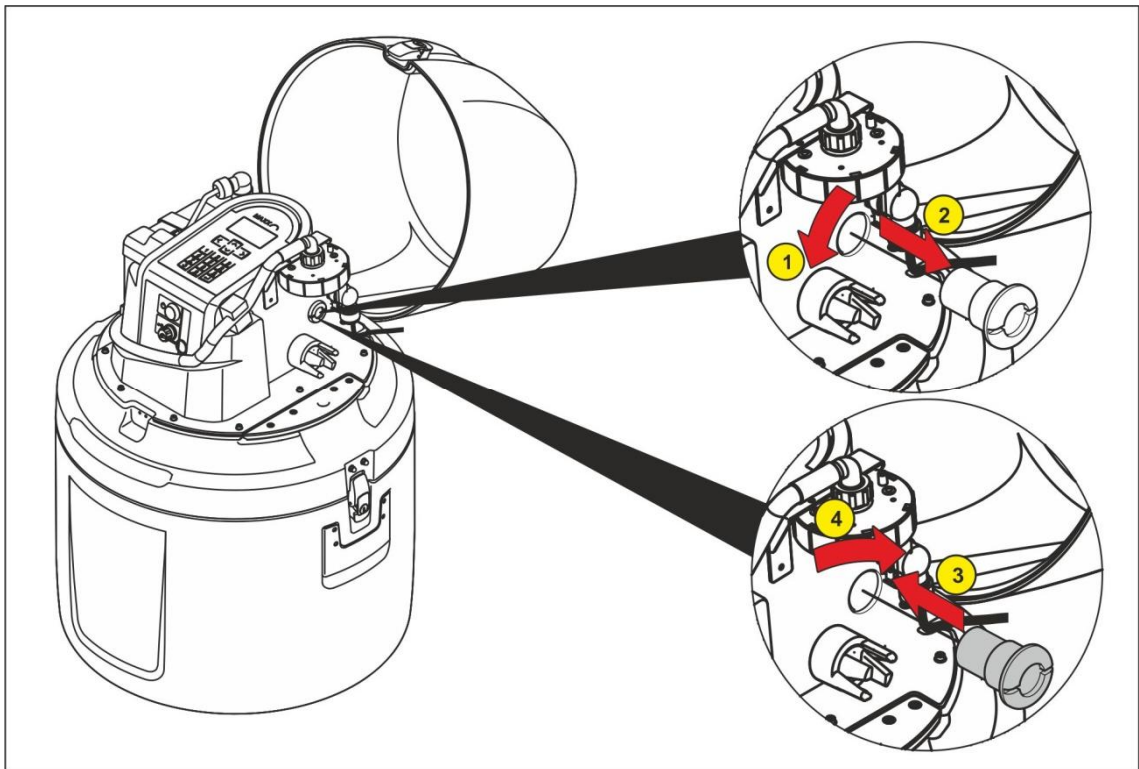

Figure 33 Desiccant replacement –Vacuumssystem

5.1.2 PUMP TUBE REPLACEMENT



Important Note: Use of tubing other than that supplied by the manufacturer may cause excessive wear on mechanical parts and/or poor pump performance!

Inspect and clean the pump tubing and rollers on a regular basis. Replace the tubing when deteriorated, at regular intervals.
Part.No. 0092216, L=245 mm

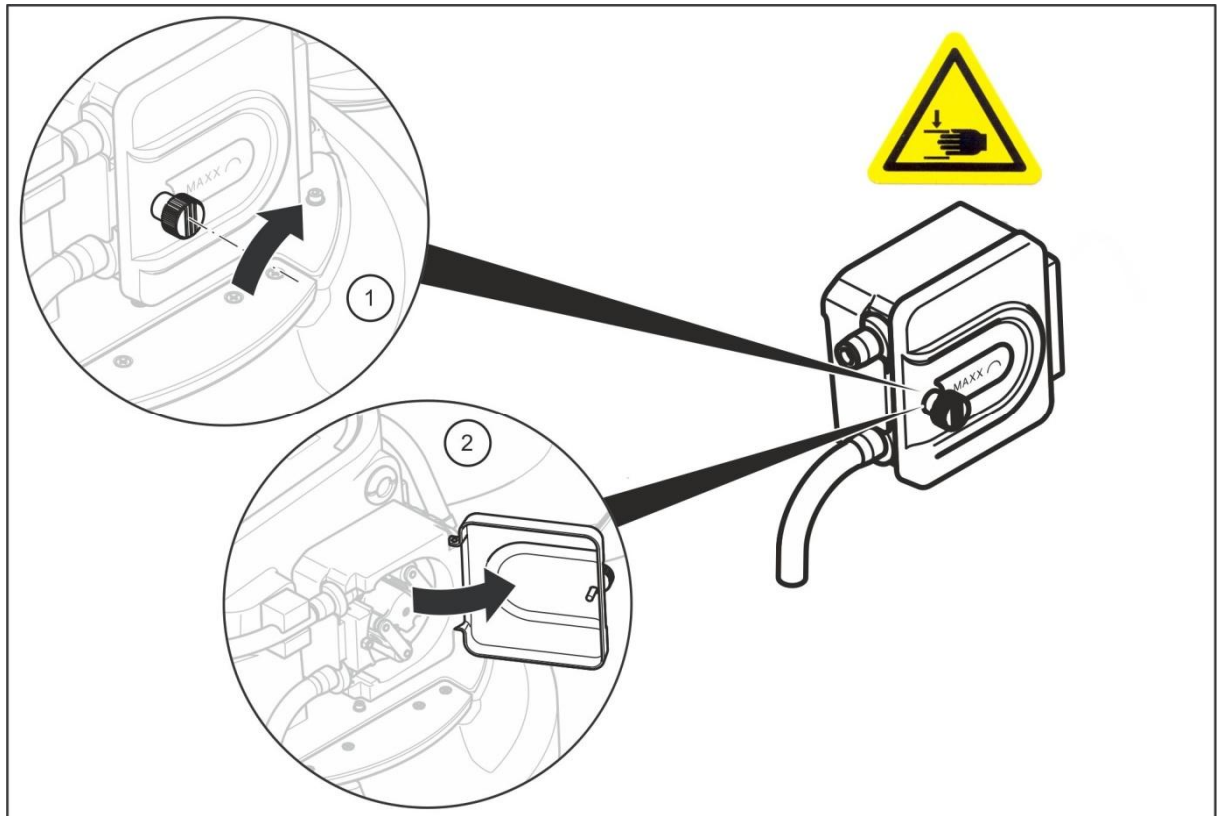

Figure 34 Pump tube replacement 1

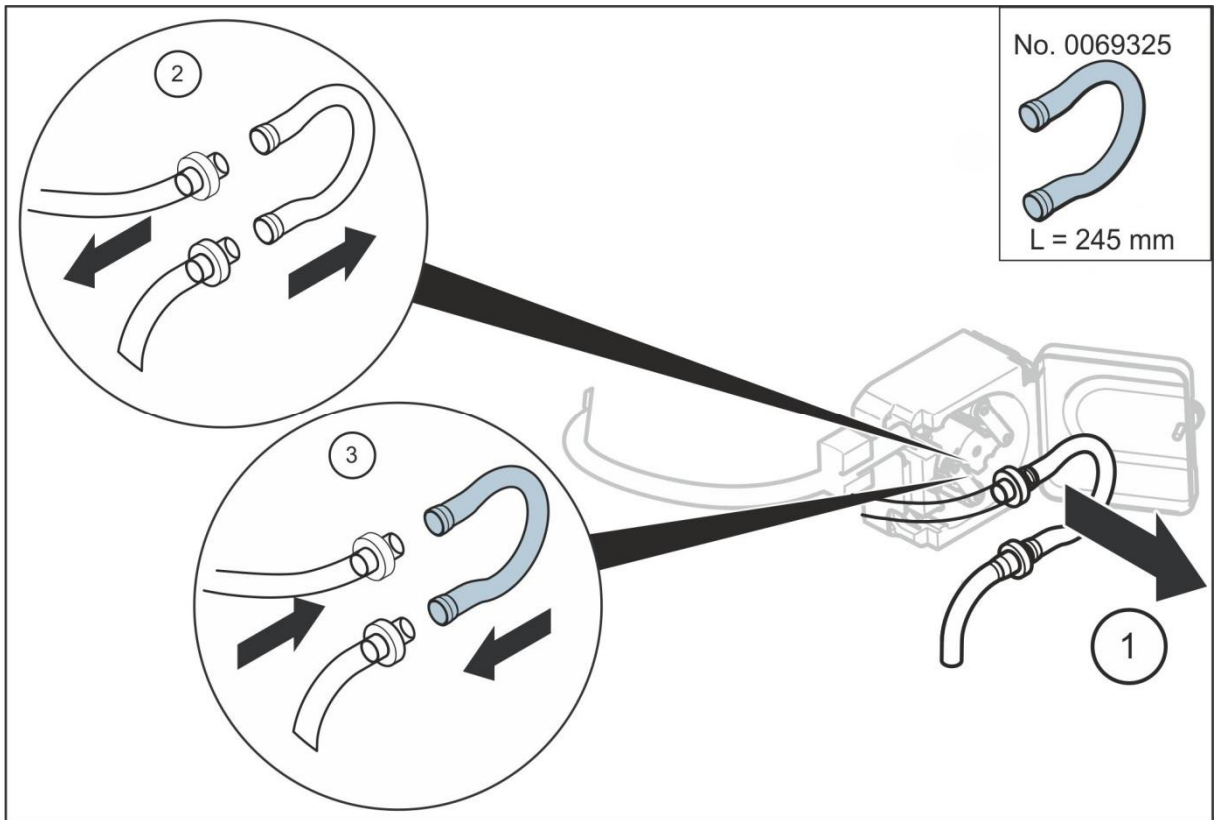

Figure 35 Pump tube replacement 2

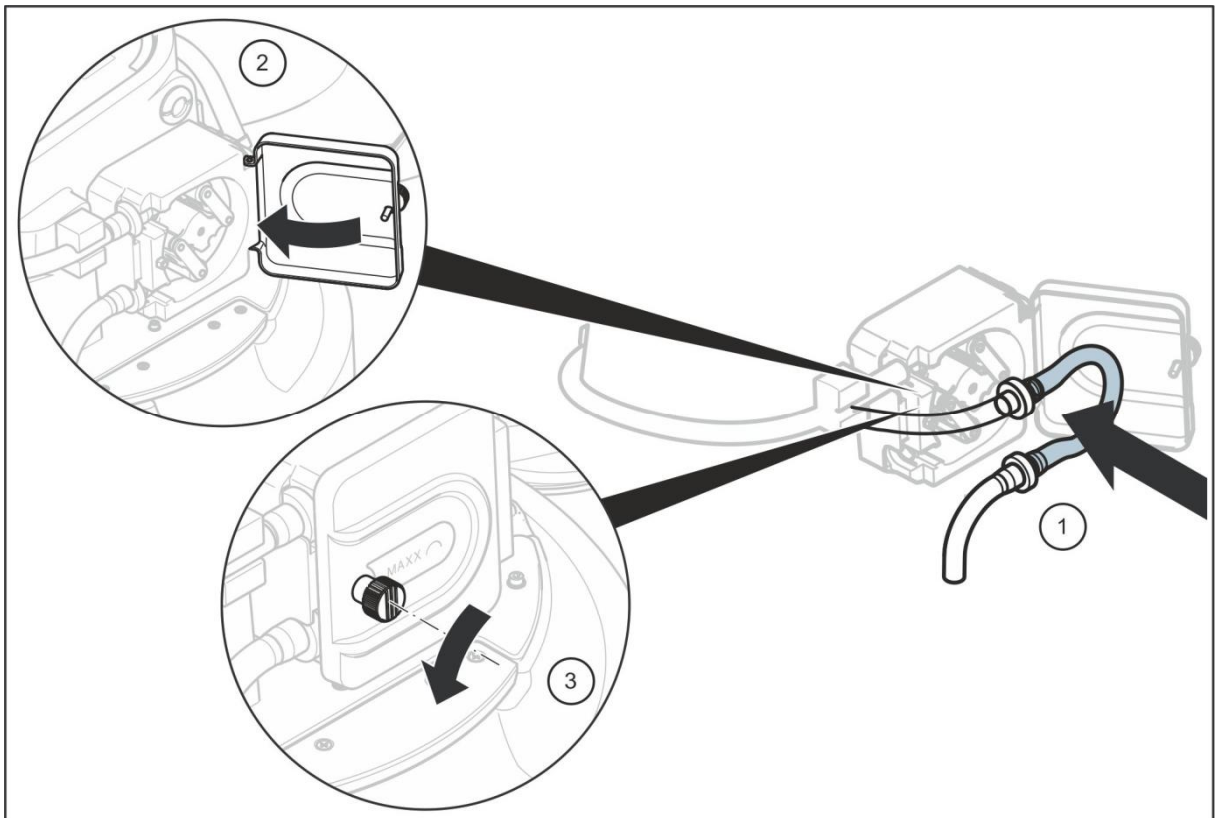

Figure 36 Pump tube replacement 3



Important Note:

The sampler measures the sampling volume with **2** capacitive Sensors. Depending to the sampling point after some time can be dirt in the silicon tube. If you get error messages (error sensor / error electrodes), you have to ***clean the tube!***

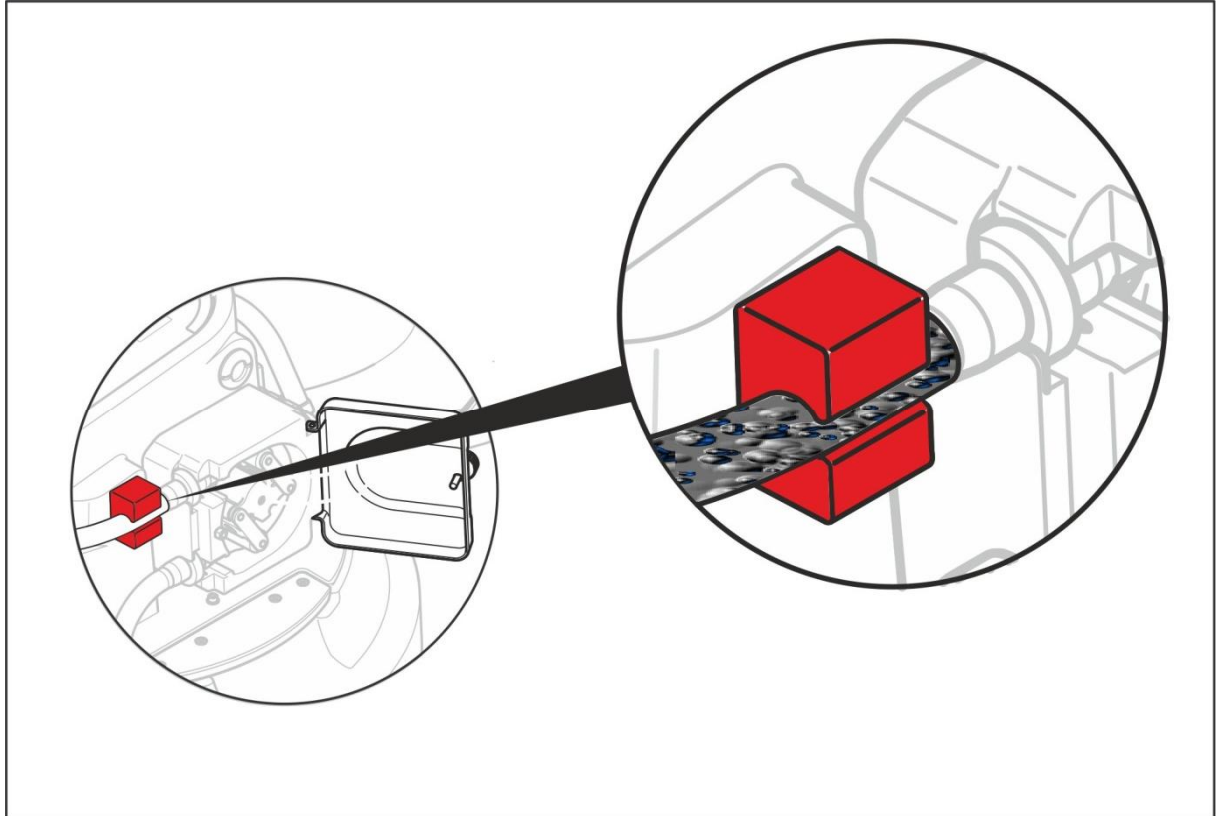

Figure 37 Peristaltic Pump – Cleaning of the tube

5.2 Cleaning

The apparatus **must be** cleaned regularly in accordance with the degree of contamination present. In

view of the quality of samples, we recommend to clean thoroughly especially the wetted parts like dosing unit, electrodes, distributor, bottles and inlet hose. Failure to do so could result in damage or destruction to the equipment, device that are not covered by warranty.

5.2.1 Clean the housing and distribution unit



WARNING!

***Manual rotation of the distribution unit can damage the drive.
Never rotate the distribution unit manually.***

Clean the interior and exterior of the housing with a damp, lint-free cloth. Add commercial household cleaner to the cleaning water as required.

1. Clean the interior and exterior of the housing with a damp, lint-free cloth. Add commercial household cleaner to the cleaning water as required..
2. Remove the top part as shown in the illustrations
3. Clean the unit around the distributor arm as required
4. Clean or replace the tubes as required (suction hose, dosing tube and tube down to the distributor arm)

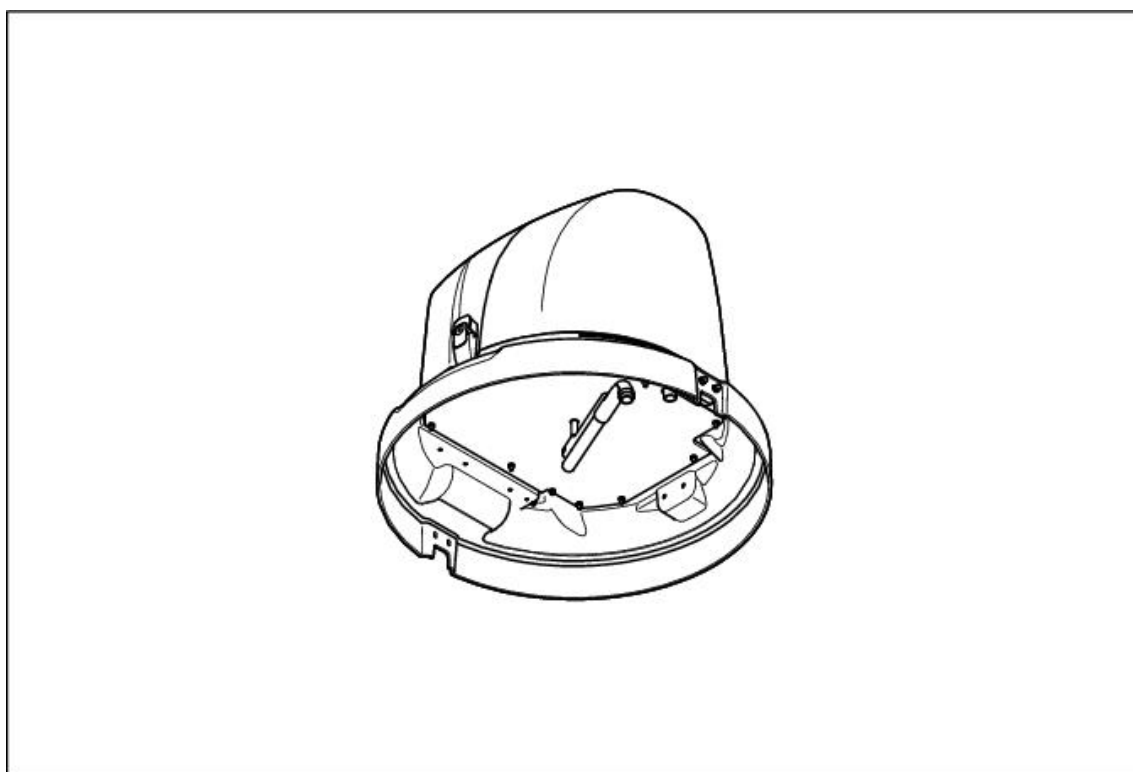

Figure 38 Distributor arm

5.2.2 Clean the dosing vessel

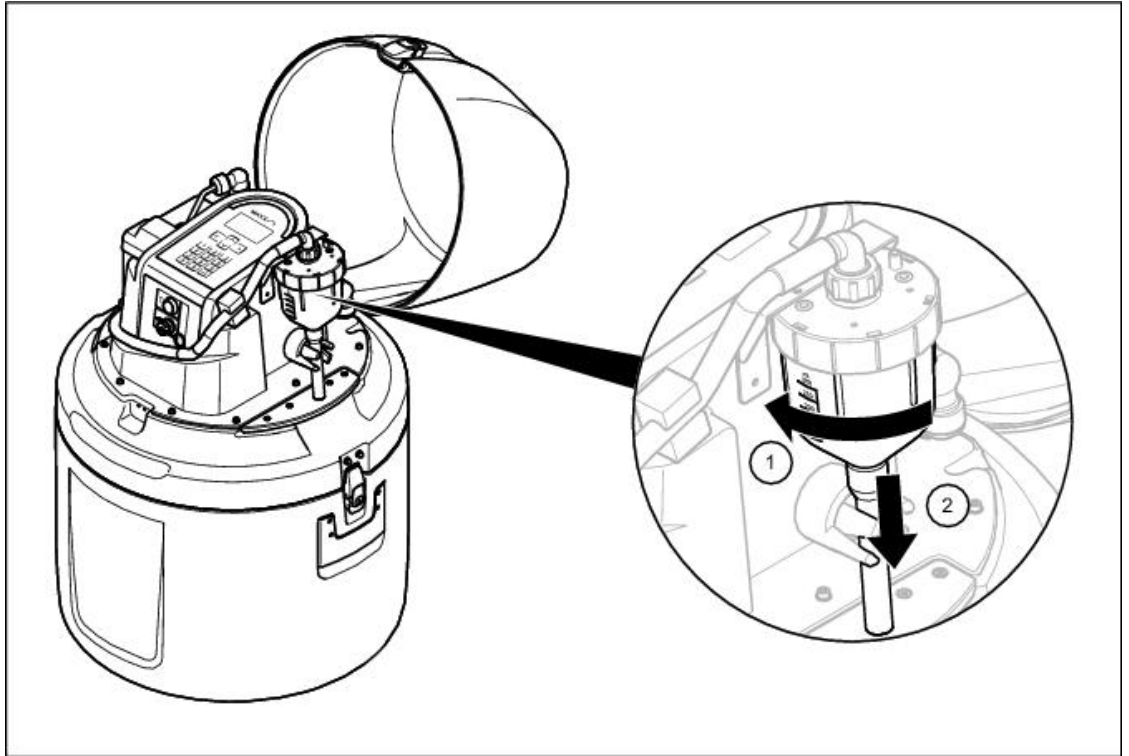

Figure 39 Release the dosing vessel

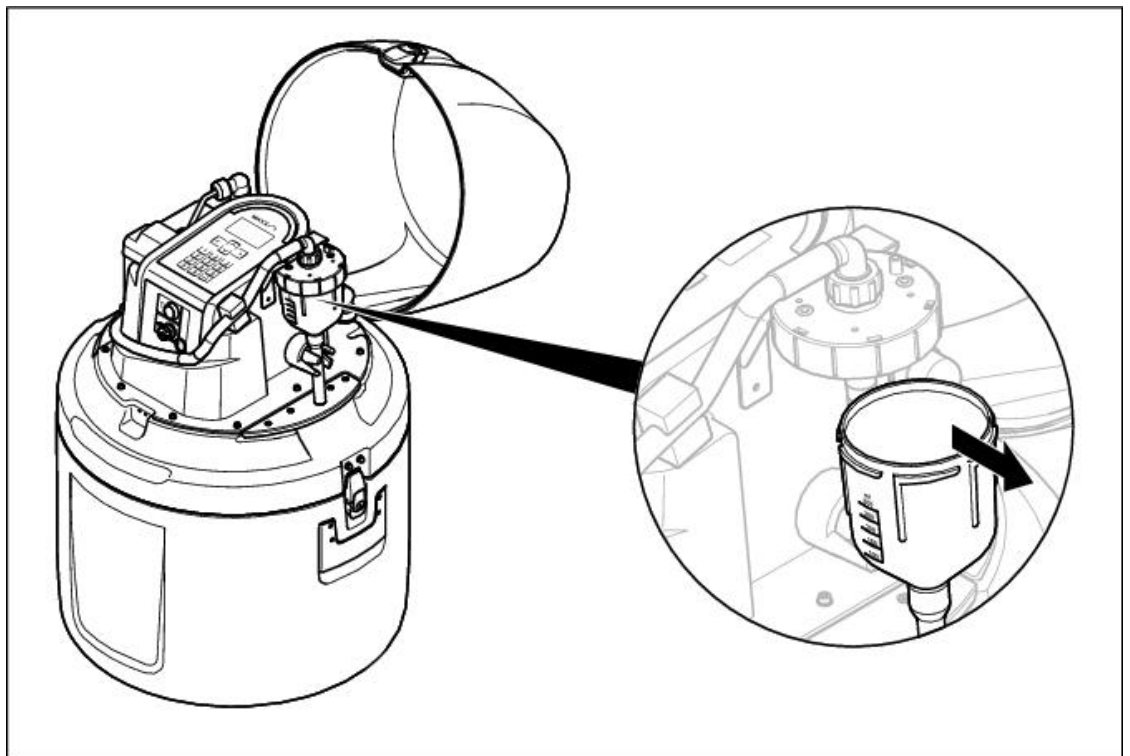

Figure 40 Remove the dosing vessel

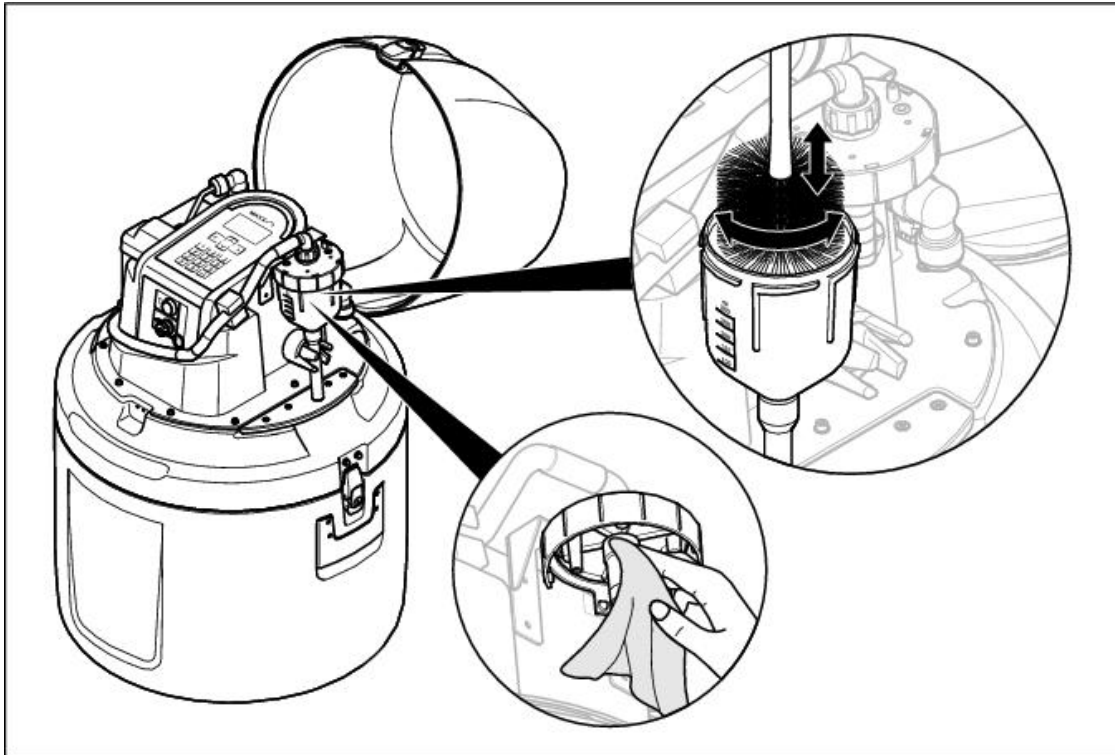

Figure 41 Clean the dosing vessel

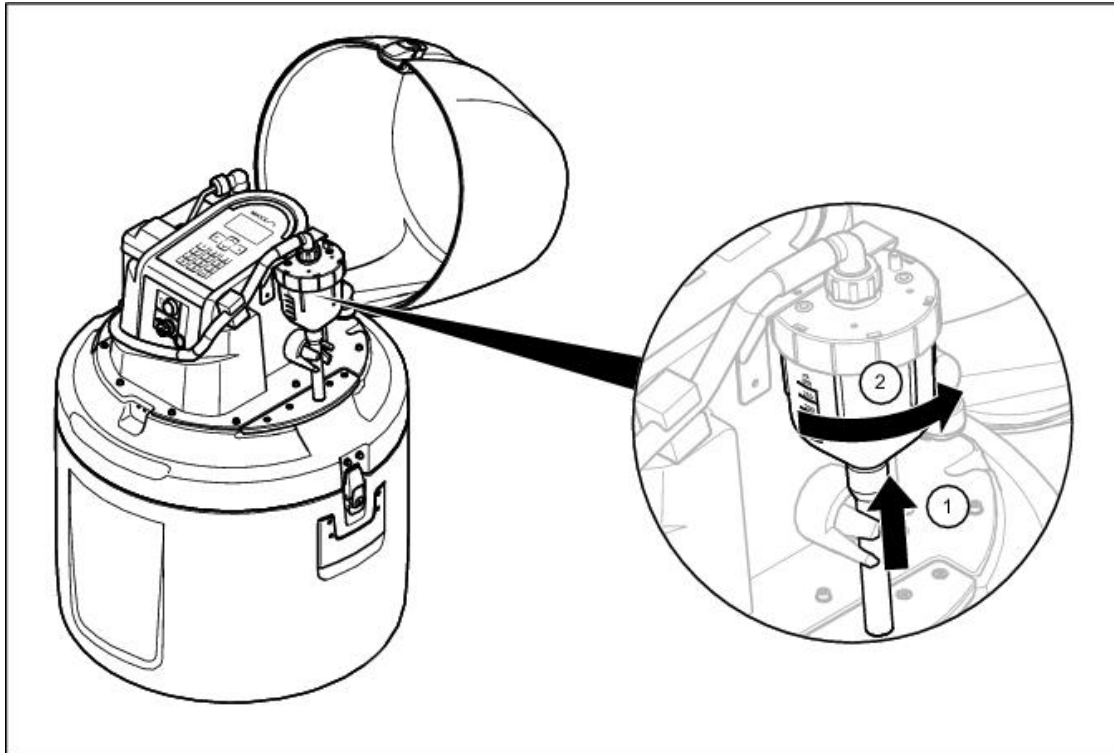

Figure 42 Insert the dosing vessel

5.3 Troubleshooting

If the equipment does not work as required, check the fuse and replace if necessary

5.3.1 Change the fuse

Open the fuse holder as shown in [Figure 42](#) and replace the defective fuse (**8 AT**).

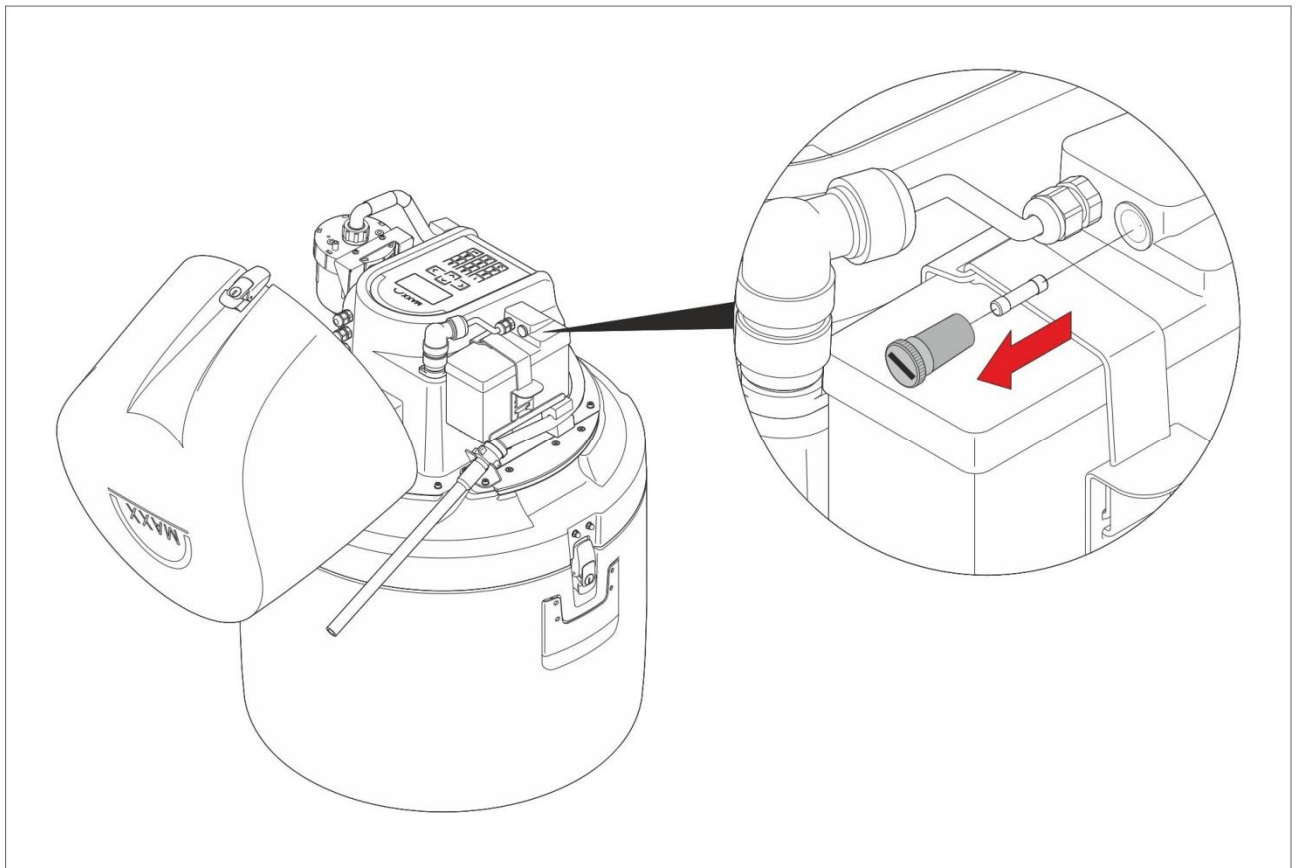

Figure 43 Position of the fuse in the portable sampler P6

If the error is not rectified, please contact the customer service of the manufacturer

5.4 Instrument decommissioning and storage

1. Close all active programs.
2. Switch the equipment off.
3. Remove all liquids and, if necessary, solid matter from the infeed and outfeed lines and bottle compartments and clean as required.

Section 6 REPLACEMENT PARTS AND ACCESSORIES

6.1 Spare parts - P6

Description	Art.Nr.
Plastic	
Replacement bottle, PE, 1 L Segment	0060584
Replacement Cap for 1 L Segment bottle	0060590
Replacement bottle, PE, 2 L	
Replacement bottle, PE, 4 L	
Replacement bottle, PE, 10 L	0060045
Glass	
Replacement bottle, glass, 350 ml	
Replacement bottle, glass, 950 ml	
Replacement bottle, glass, 2 L	

6.1.1 Spare parts P6 Peristaltic Pump

Description	Art.Nr.
Replacement Tube	0901062
Tube between the Sensors	0901063
Tube to distributor arm	0901064
Tube connector	0050695-VA

6.1.1 Spare parts P6 Vacuum Dosingsystem

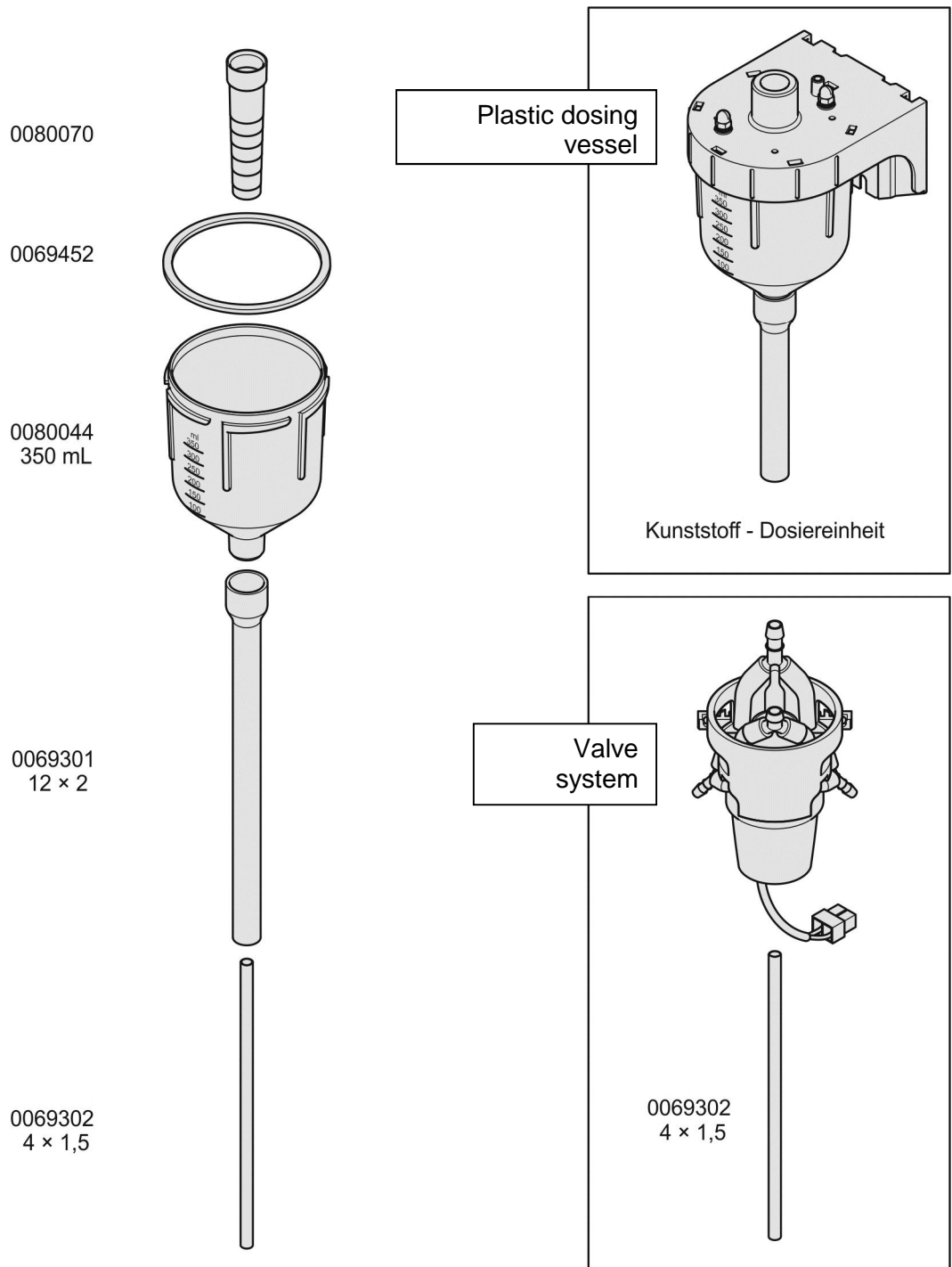

Figure 44 Vacuum Plastic dosing vessel

P6 Vacuum

Description	Art.Nr.
Tube between the Sensors VAR-System	0069325
Tube to distributor arm	0069301

6.2 Accessories

Description	Art.Nr.
Y cable, power supply	0069810
Charger IP20	0900026
Charger IP65	0900033
Signal cabel 10 m	0069644
Suction hose, ready for connection	0900812
Replacement cold pack	0060251
Transportation trolley	0900802
Replacement battery set 7,5 Ah with connection cable	0901055
USB data cable - USB2 to USB Mini -	0069793

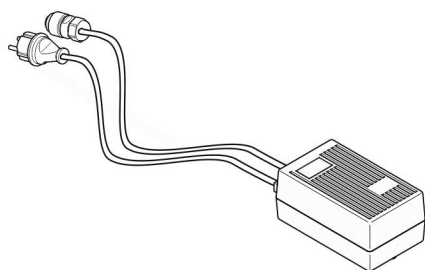

Figure 45 Charger IP20

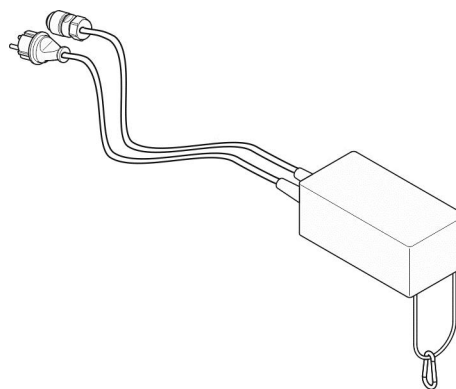

Figure 46 Charger IP65

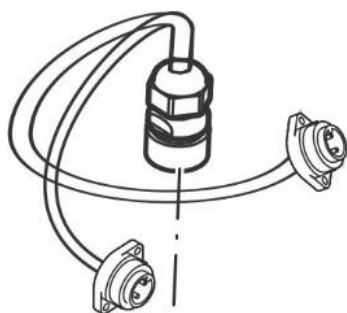

Figure 47 Y-cable

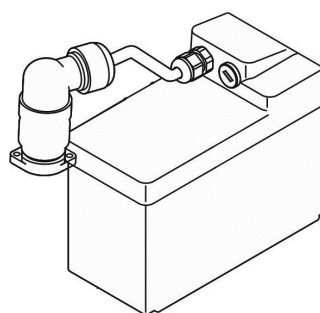

Figure 48 Replacement battery pack

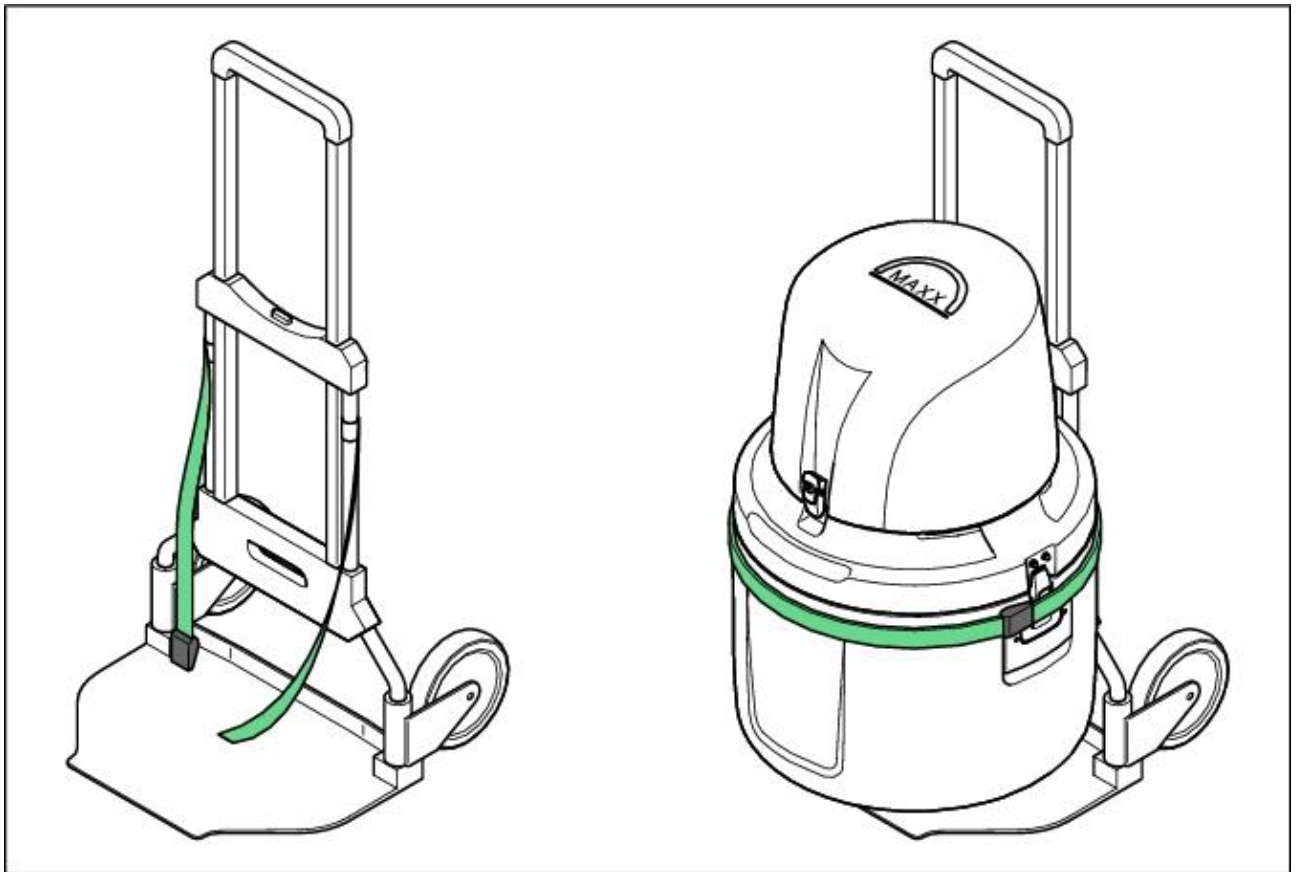

Figure 49 Transportation trolley

Section 7 WARRANTY AND LIABILITY

The manufacturer warrants that the product supplied is free of material and manufacturing defects and undertakes the obligation to repair or replace any defective parts at zero cost.

The warranty period is **12 months** from delivery resp. invoice date. Consumables and damage caused by improper handling, poor installation or incorrect use are excluded from this clause

With the exclusion of the further claims, the supplier is liable for defects including the lack of assured properties as follows: all those parts that, within the warranty period calculated from the day of the transfer of risk, can be demonstrated to have become unusable or that can only be used with significant limitations due to a situation present prior to the transfer of risk, in particular due to incorrect design, poor materials or inadequate finish will be improved or replaced, at the supplier's discretion. The identification of such defects must be notified to the supplier in writing without delay, however at the latest 7 days after the identification of the fault. If the customer fails to notify the supplier, the product is considered approved despite the defect. Further liability for any direct or indirect damages is not accepted.

If instrument-specific maintenance and servicing work defined by the supplier is to be performed within the warranty period by the customer (maintenance) or by the supplier (servicing) and these requirements are not met, claims for damages due to the failure to comply with the requirements are rendered void.

Any further claims, in particular claims for consequential damages cannot be made.

Consumables and damage caused by improper handling, poor installation or incorrect use are excluded from this clause.

List of Figures

Figure 1 Dimension	6
Figure 2 Scope of delivery (P6 L MAXX)	9
Figure 3 Scope of delivery (P6 MINI MAXX)	9
Figure 4 Required tools (P6 L and P6 MINI MAXX).....	11
Figure 5 Select installation location (P6 L and P6 MINI MAXX).....	12
Figure 6 Position the equipment (P6 L and P6 MINI MAXX).....	12
Figure 7 connect the Y-cabel	14
Figure 8 connect the Y-cabel with the charger	15
Figure 9 Connection plan for the optional signal cable (0069644)	15
Figure 10 Connection to a PC.....	16
Figure 11 Switch-on and off	17
Figure 12 Connect the Intake tube	18
Figure 13 Installation diagram.....	18
Figure 14 Unlock the bayonet cap on the plastic dosing vessel.....	19
Figure 15 Remove the plastic dosing vessel	19
Figure 16 Cut the dosing tube to set the sample volume.....	20
Figure 17 Assemble the plastic dosing vessel.....	20
Figure 18 Unit with the VAR Sensors (optional)	21
Figure 19 Calibrate the flow-proportional dosing vessel in the “Settings”Menu.....	21
Figure 20 Unit with Peristaltic Pump.....	22
Figure 21 Set of the sample volume.....	22
Figure 22 Calibrate the Peristaltic Pump for flow-proportional sampling.....	23
Figure 23 Remove the top part of the housing.....	24
Figure 24 Place the empty bottles into the bottle compartment	25
Figure 25 <i>Position for bottle No. 1</i>	25
Figure 26 Attach the top part of the housing	26
Figure 27 Rating label.....	27
Figure 28 Connect the charger with the Y-cable.....	28
Figure 29 Control panel.....	29
Figure 30 Start the program	31
Figure 31 Replace full bottles.....	32
Figure 32 Desiccant replacement–Peristaltic Pump	34
Figure 33 Desiccant replacement –Vacuumsystem.....	35
Figure 34 Pump tube replacement 1	36
Figure 35 Pump tube replacement 2	37
Figure 36 Pump tube replacement 3	37
Figure 37 Peristaltic Pump – Cleaning of the tube.....	38
Figure 38 Distributor arm	39
Figure 39 Release the dosing vessel	40
Figure 40 Remove the dosing vessel	40
Figure 41 Clean the dosing vessel	41
Figure 42 Insert the dosing vessel.....	41
Figure 43 Position of the fuse in the portable sampler P6	42
Figure 44 Vacuum Plastic dosing vessel.....	45
Figure 45 Charger IP20.....	47
Figure 46 Charger IP65.....	47
Figure 47 Y-cable.....	47
Figure 48 Replacement battery pack.....	47
Figure 49 Transportation trolley	48

MAXX Mess- u. Probenahmetechnik GmbH

Hechinger Str. 41, D-72414 Rangendingen

Tel. +49(0)7471-98481 0 Fax +49(0)7471-98481 44

www.maxx-gmbh.com

info@maxx-gmbh.com