



1200 Data Sheet



SERIES: 1000 WOOD GRILLES

STYLE: 1200 DOWEL GRILLE

Overview

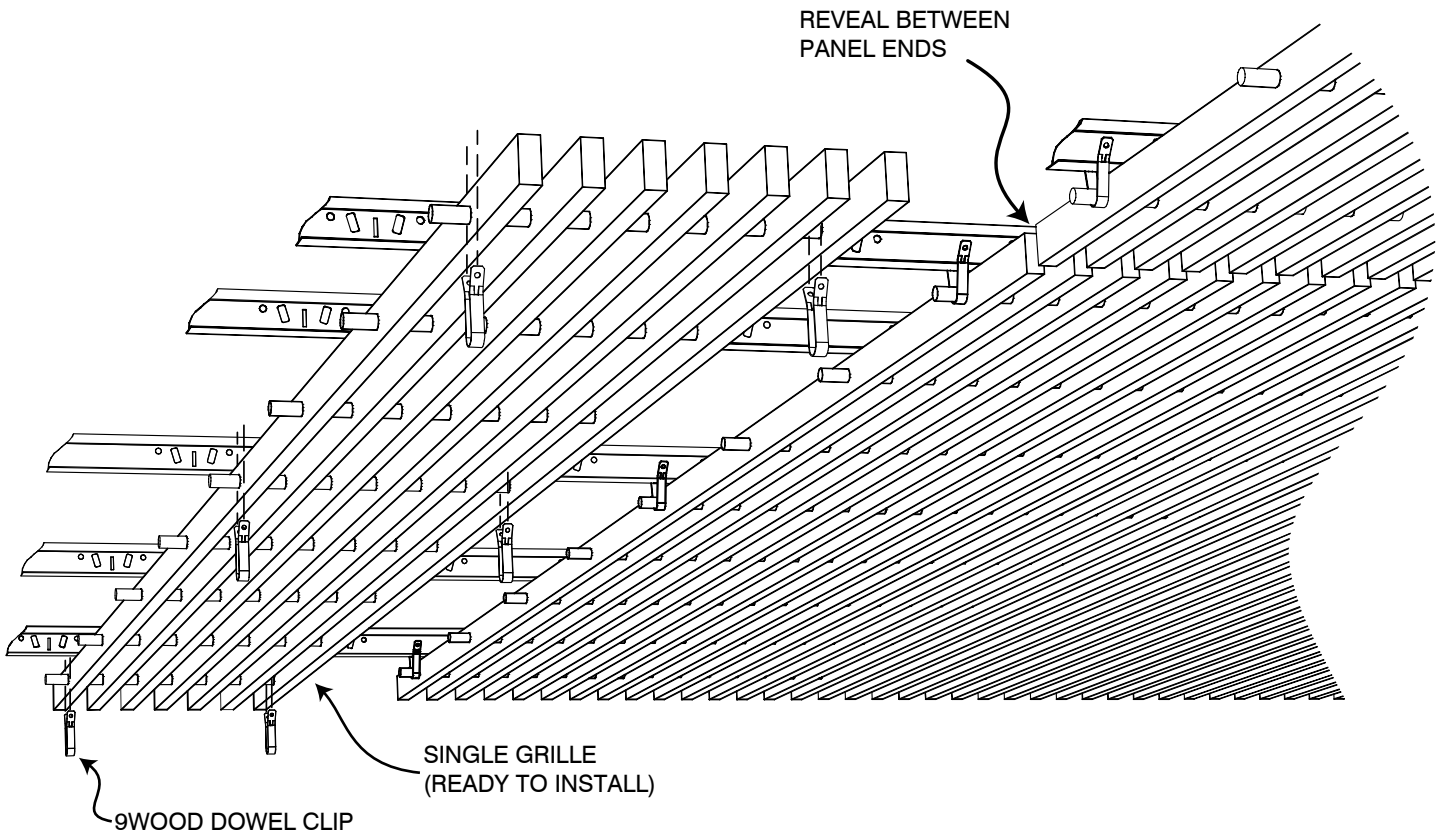

The **9Wood Dowel Grille** wood ceiling offers a design where the individual wood member is deeper than it is wide. The standard panel width is 12". Standard panel lengths are 4', 6', 8', or 10' (nominal).

Attachment for the Dowel Grille is via 9Wood Dowel Clips in non-seismic zones for a high level of accessibility. In seismic zones a supplemental cross piece backer is required (see 1400 Dowel/Cross Piece Grilles).





1200 Data Sheet



SERIES: 1000 WOOD GRILLES

STYLE: 1200 DOWEL GRILLE

Product Data

Application

The Dowel Grille uses a pre-assembled panel fabrication process. The 1200 Dowel Grille style is often specified for member depths greater than 3" to provide greater structural integrity. This product is easily accessible and installs efficiently to T-Bar grid via a dowel clip. The 1200 Dowel Grille Style should be considered when frequent accessibility is required or when deep members (>3") are desired.

Performance

Acclimatization

Dowel Grilles must be cared for in a controlled interior environment (RH 25%-55% max; temp. 60°-80°) and installed only after reaching equilibrium moisture content. Should the building fall outside these limits consult 9Wood, Inc. for our 3 Tests/3 Tracks Acclimatization Advisory.

Acoustics

The Dowel Grille can enhance acoustics via sound-absorbing material placed over open reveals within the T-Bar grid. Insulation is typically provided locally.

Fire Rating

Individual members and components can be treated with Class I (A) Fire Retardant chemicals (solid wood use FR coatings, veneered particleboard use FR formulas). Particular species or styles have not been tested.

LEED

Dowel Grilles may qualify toward MR-3, MR-4.1/4.2, MR-5.1/5.2, MR-6, MR-7, IEQ-4.2 or IEQ-4.4. As all products are custom-fabricated, LEED credit opportunities are project by project. Please contact 9Wood, Inc. for specifics.

MEP

The Dowel Grille permits MEP penetrations in the ceiling's surface. Cut panels may require supplemental reinforcement. Fixtures and diff users must be independently supported.

Seismic

Dowel Grilles can provide seismic code compliance by means of mechanical direct screw attachment to T-Bar via supplemental cross-piece backers, eliminating the nonseismic dowel clips. Please consult local code or a licensed engineer for any additional requirements.

Species & Finishes

9Wood can offer both domestic and imported species for the Dowel Grille. Clear, satin sheen finish is standard; custom stain matches are available.

Suspension

Dowel Grilles are clipped onto 15/16" heavy duty T-Bar main runners. Main runners are typically 2' on center.

System Weight

Dowel Grilles typically weigh 2-4 pounds per square foot, depending on members per linear foot and species.



1200 Data Sheet



SERIES: 1000 WOOD GRILLES

STYLE: 1200 DOWEL GRILLE

Typical Specifications

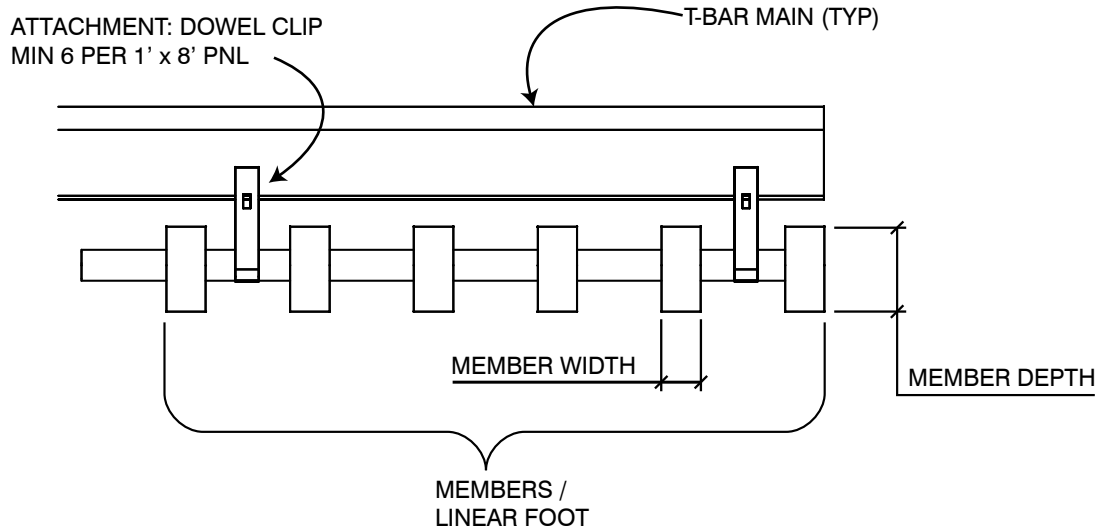

SKU Table

Width (Softwood)	Width (Hardwood)	Width (Veneer)	Depth	Grille Members per Linear Foot									
				2	3	4	5	6	7	8	9	10	
5/8"	3/4"	3/4"	1 3/8"	1212-2	1212-3	1212-4	1212-5	1212-6	1212-7	1212-8	1212-9	1212-10	
5/8"	3/4"	3/4"	2 1/4"	1213-2	1213-3	1213-4	1213-5	1213-6	1213-7	1213-8	1213-9	1213-10	
5/8"	3/4"	3/4"	3 1/4"	1214-2	1214-3	1214-4	1214-5	1214-6	1214-7	1214-8	1214-9	1214-10	
1 3/8"	1 3/8"	1 7/16"	1 3/8"	1222-2	1222-3	1222-4	1222-5	1222-6	[Patterned Area]				
1 3/8"	1 3/8"	1 7/16"	2 1/4"	1223-2	1223-3	1223-4	1223-5	1223-6					
1 3/8"	1 3/8"	1 7/16"	3 1/4"	1224-2	1224-3	1224-4	1224-5	1224-6					
1 3/8"	1 3/8"	1 7/16"	5 1/4"	1226-2	1226-3	1226-4	1226-5	1226-6					

* Other width, depth and M/LF combinations available. Please inquire.

** Please see 9wood.com for information on appropriate species selections.



1200 Data Sheet



SERIES: 1000 WOOD GRILLES

STYLE: 1200 DOWEL GRILLE

Perimeter Conditions and Suspension

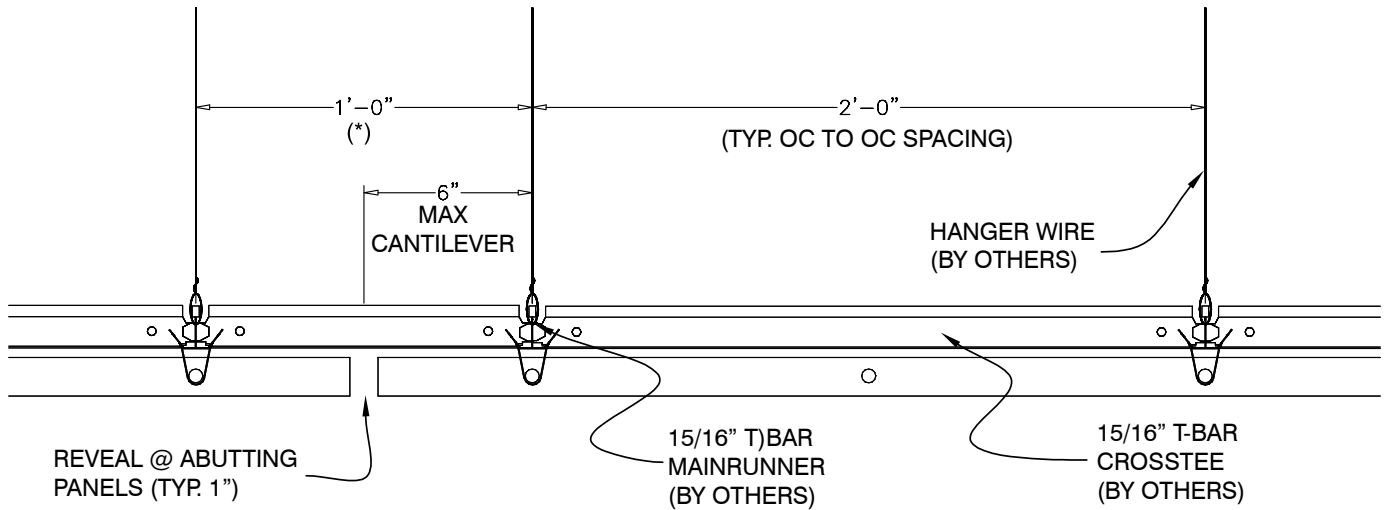

NOTE: A CENTER REVEAL TYPICALLY REQUIRES A CUSTOM OC SPACING IN THE SUSPENSION SYSTEM

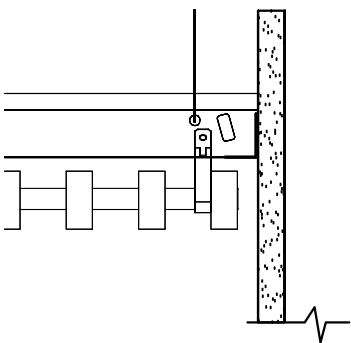

FLOATING:
OPEN REVEAL

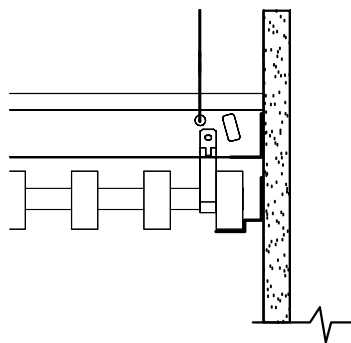

METAL TRIM:
CONT. SHADOW STYLE
WALL ANGLE

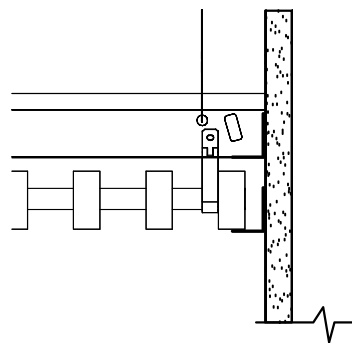

METAL TRIM:
CONT. WALL ANGLE

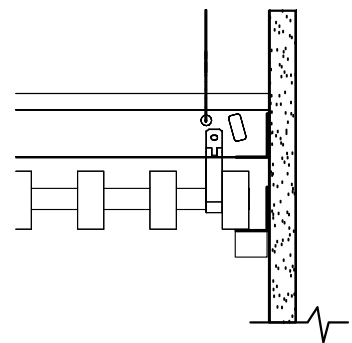

WOOD TRIM:
CONT. WALL ANGLE
W/WOOD TRIM