

PROJECT CERTIFICATIONS: YES NO

PROJECT

PROJECT NUMBER:
PROPOSAL NUMBER:

REVISION HISTORY

REV#	DATE	DESCRIPTION
10		
9		
8		
7		
6		
5		
4		
3		
2		
1		
0	08.29.25	RELEASE FOR APPROVALS

SHEET INFORMATION

DRAWING TYPE: SHOP DRAWINGS
DRAWN BY: ARZ
STANDARDS REVIEW: RAC
TECHNICAL REVIEW: RAC

THIS DOCUMENT CONTAINS PROPRIETARY INFORMATION OF 9WOOD, INC.
COPYRIGHT © 2025 9WOOD, INC.
ALL RIGHTS RESERVED.

KEY NOTES

- 1 15/16" HEAVY DUTY T-BAR MAIN RUNNER (TYP. BY SUBCONTRACTOR)
- 2 15/16" T-BAR CROSS TEE (TYP. BY SUBCONTRACTOR)
- 3 HANGER WIRE (TYP. BY SUBCONTRACTOR)
- 4 WALL ANGLE AND APPROPRIATE INSTALLATION FASTENER (TYP. BY SUBCONTRACTOR)
- 5 PERIMETER CONDITION (TYP. BY OTHERS)

SHEET TITLE

SYSTEM DETAILS

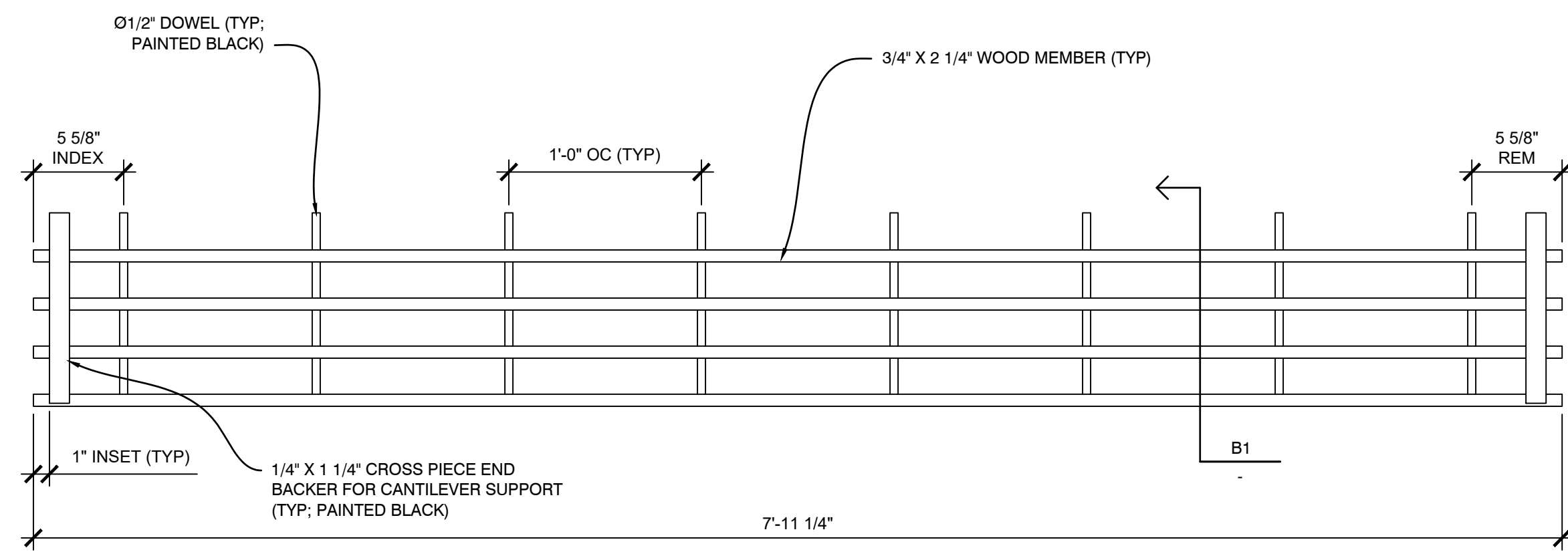

C1 PLAN VIEW - DOWEL CEILING GRILLE
SCALE: 1 1/2" = 1'

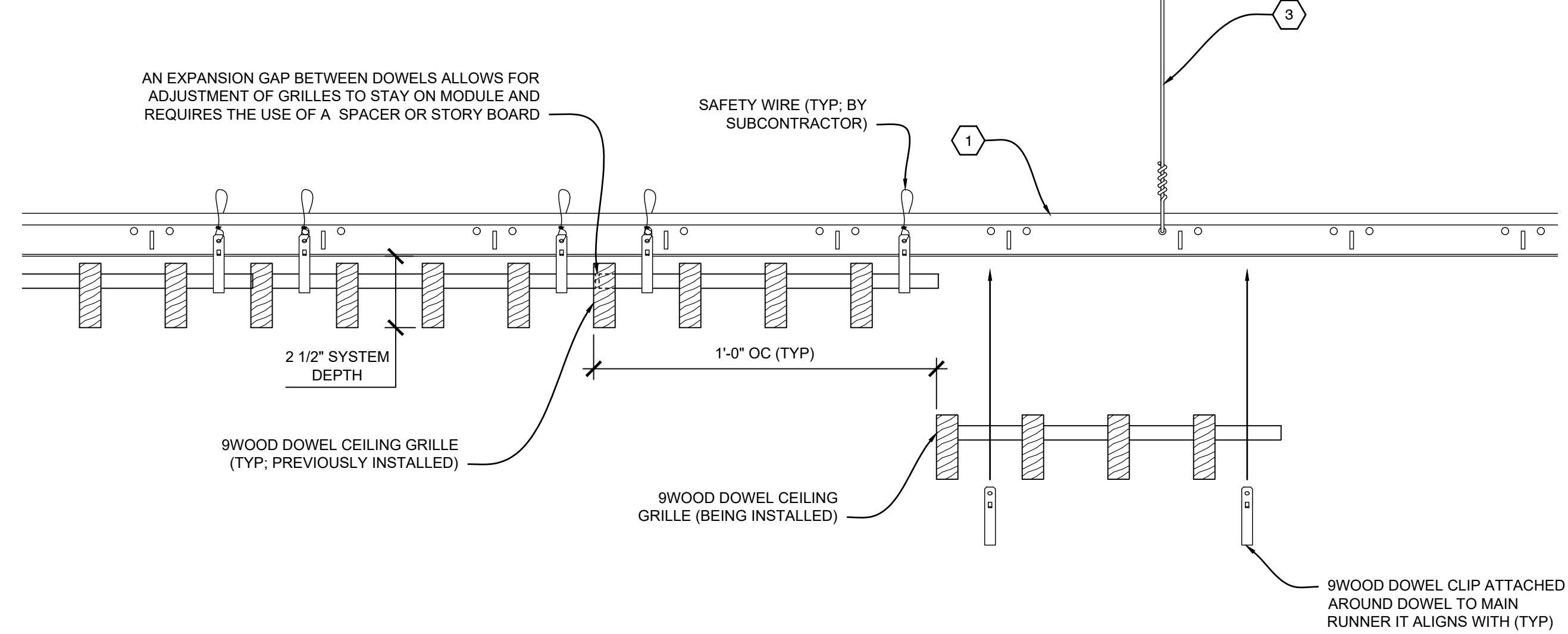

C3 INSTALLATION PROCESS - DOWEL CEILING GRILLE
SCALE: 1/4" = 1'

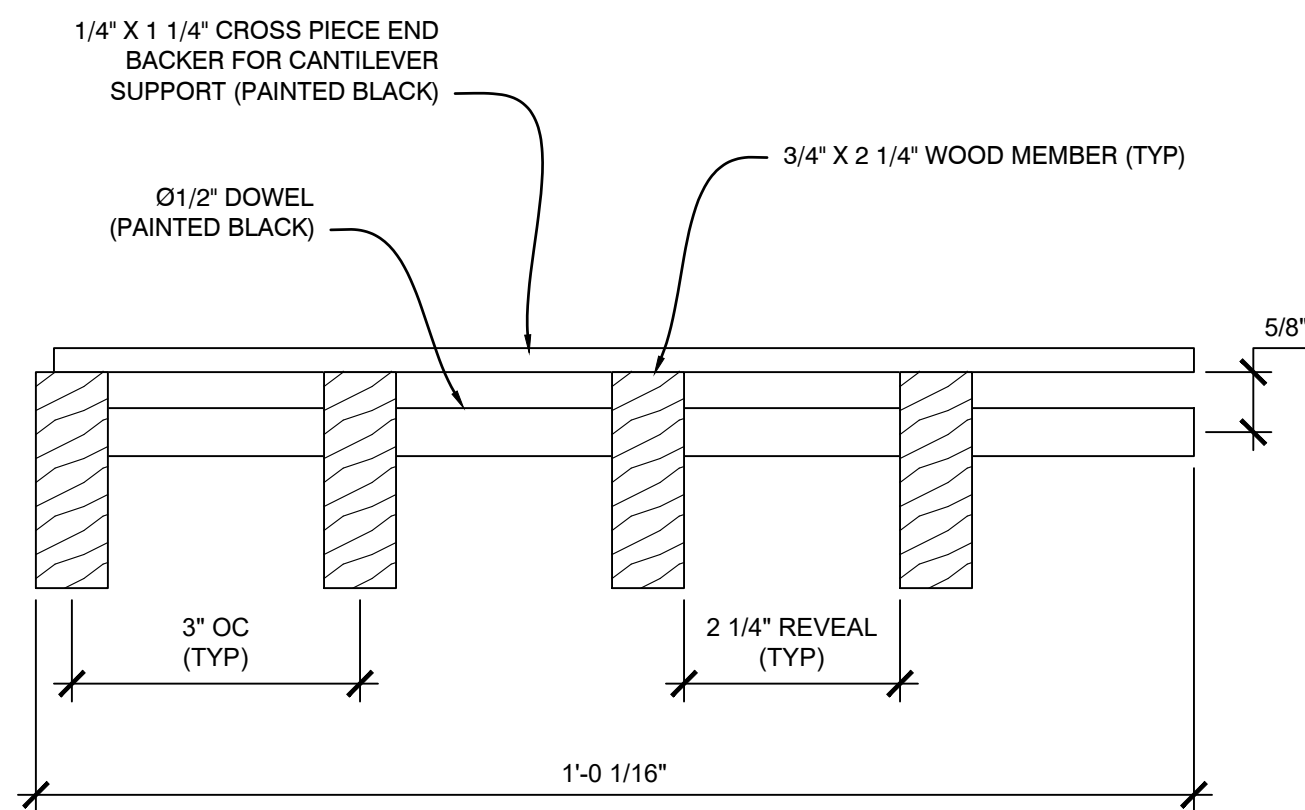

B1 SECTION - DOWEL CEILING GRILLE
SCALE: 1/2" = 1'

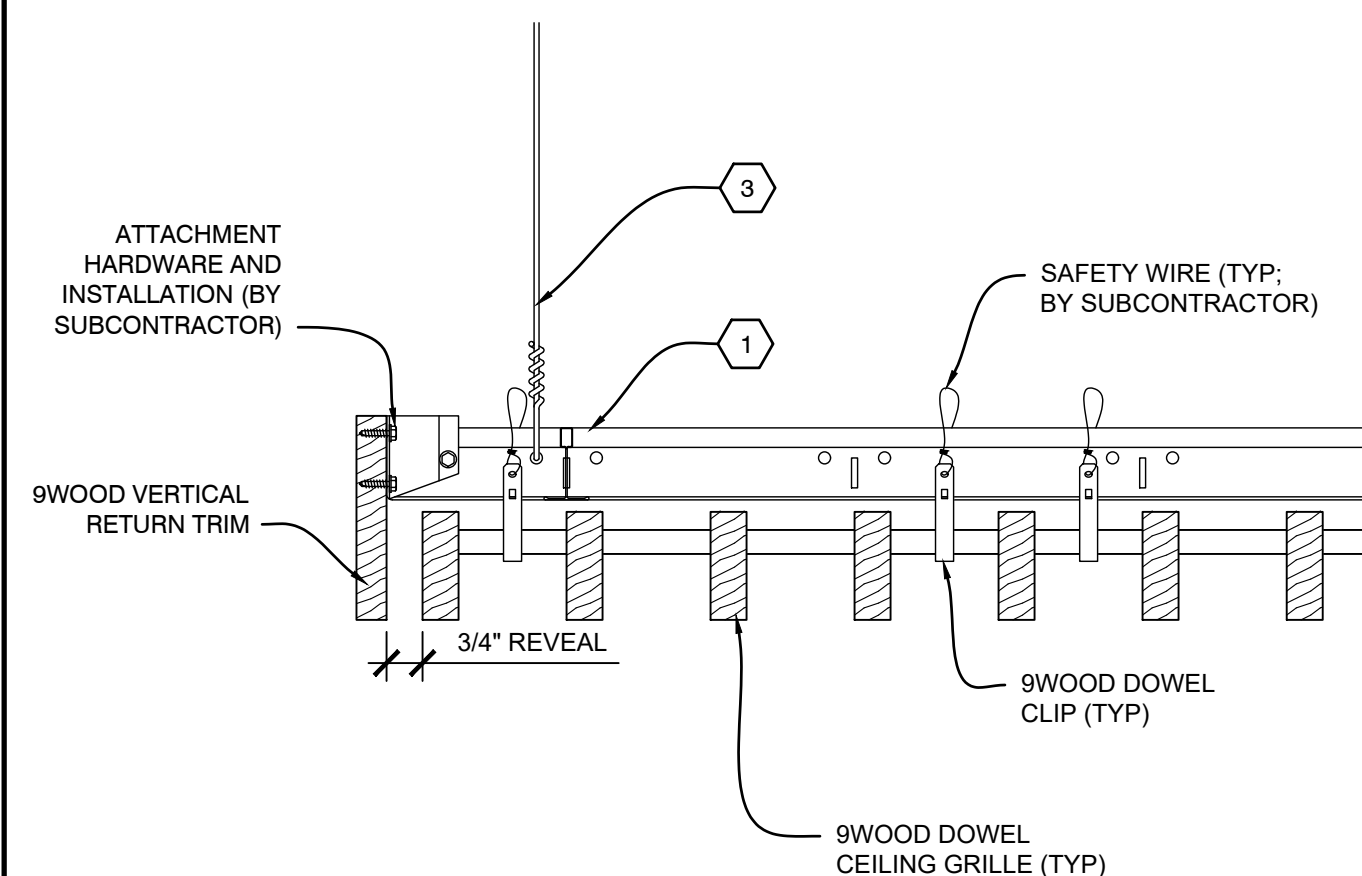

B2 SECTION - PERIMETER
SCALE: 1/4" = 1'

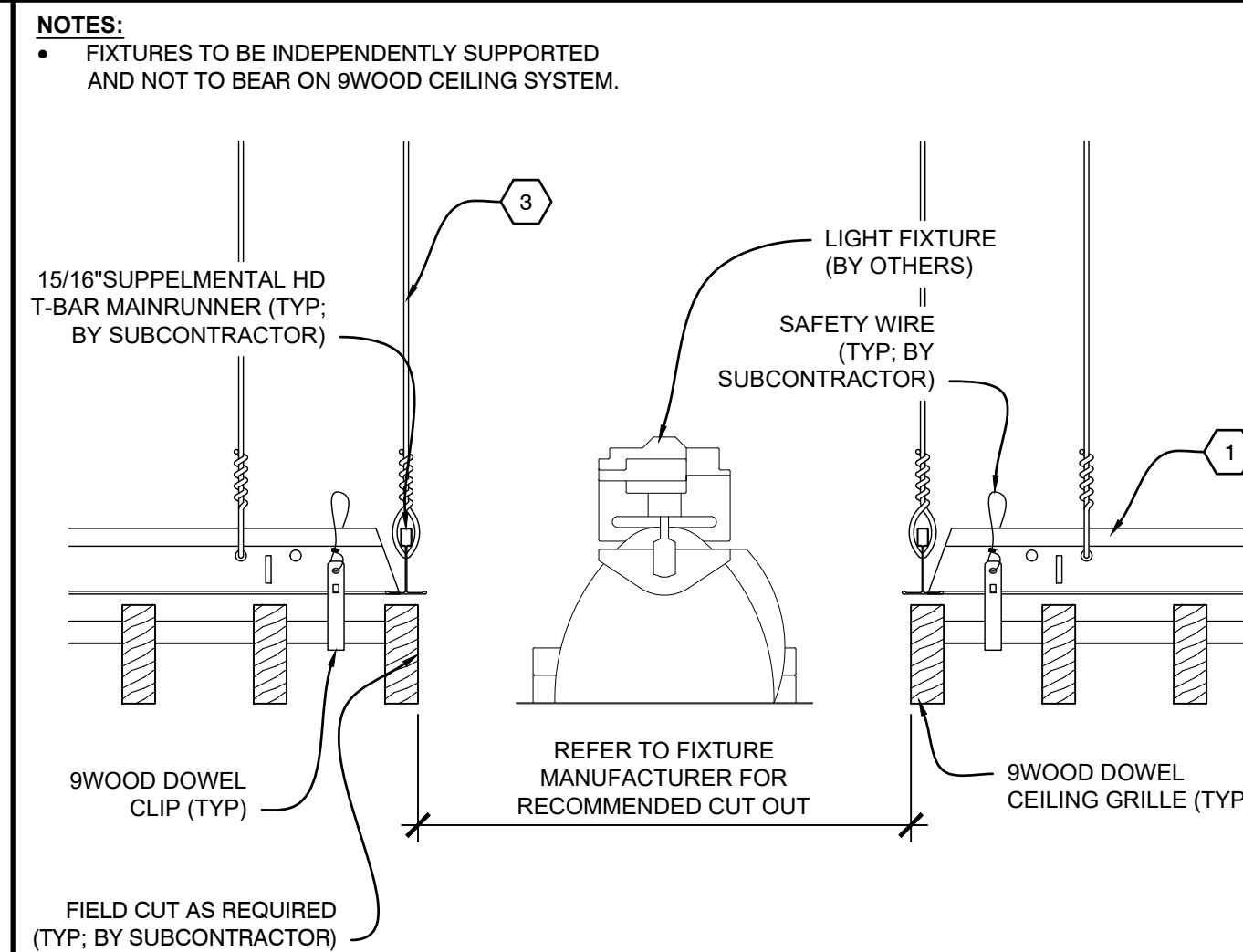

B3 SECTION - LIGHT FIXTURE
SCALE: 1/4" = 1'

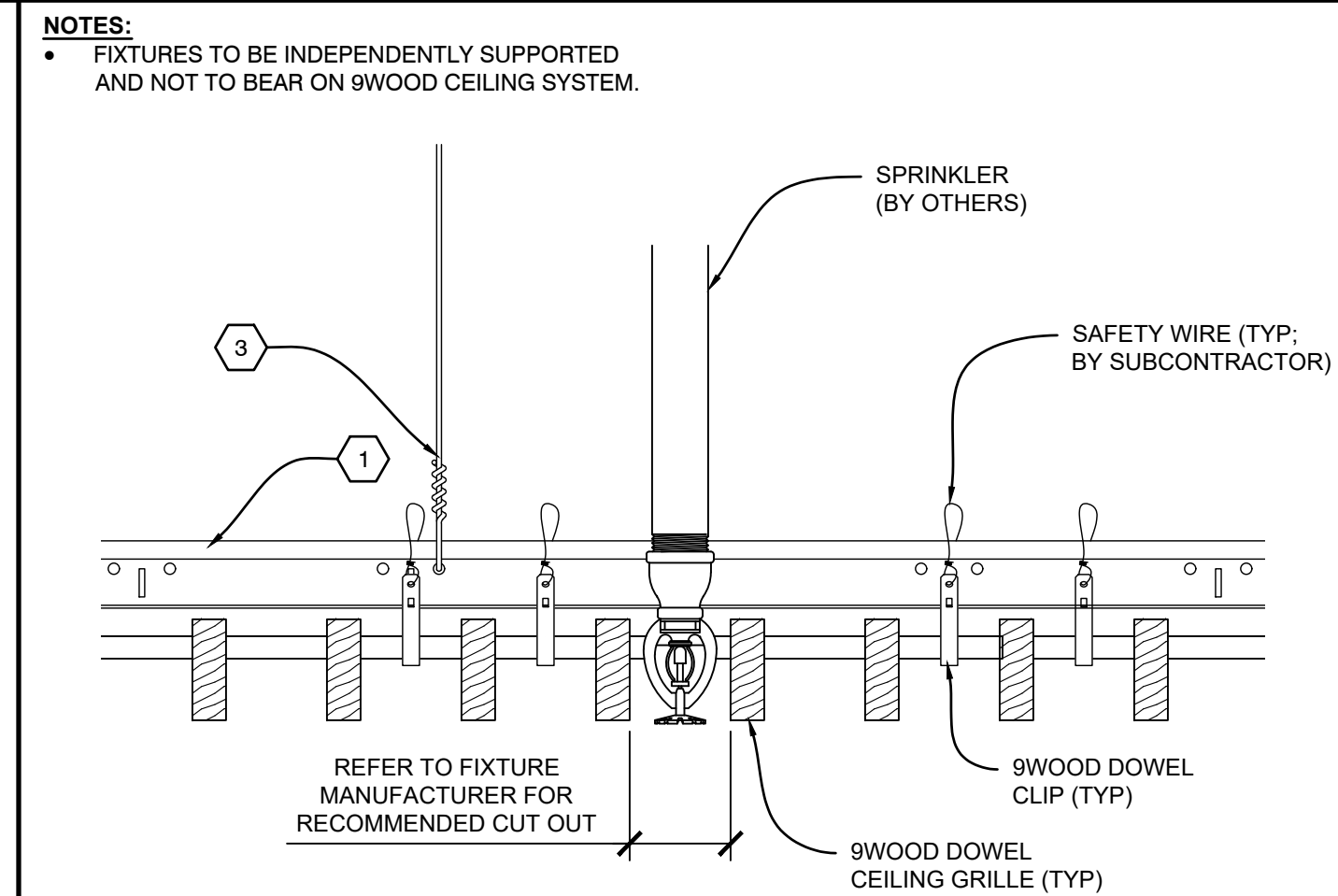

B4 SECTION - SPRINKLER
SCALE: 1/4" = 1'

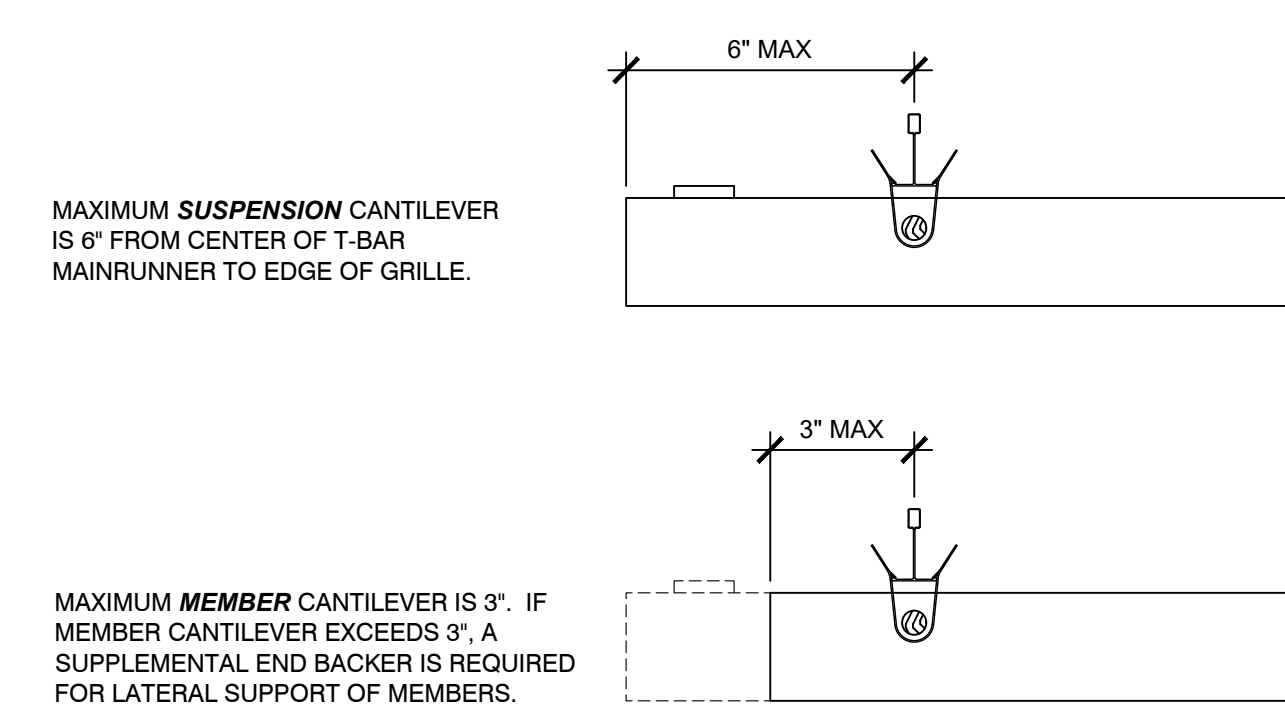

A1 SECTION - CANTILEVER
SCALE: 1/4" = 1'

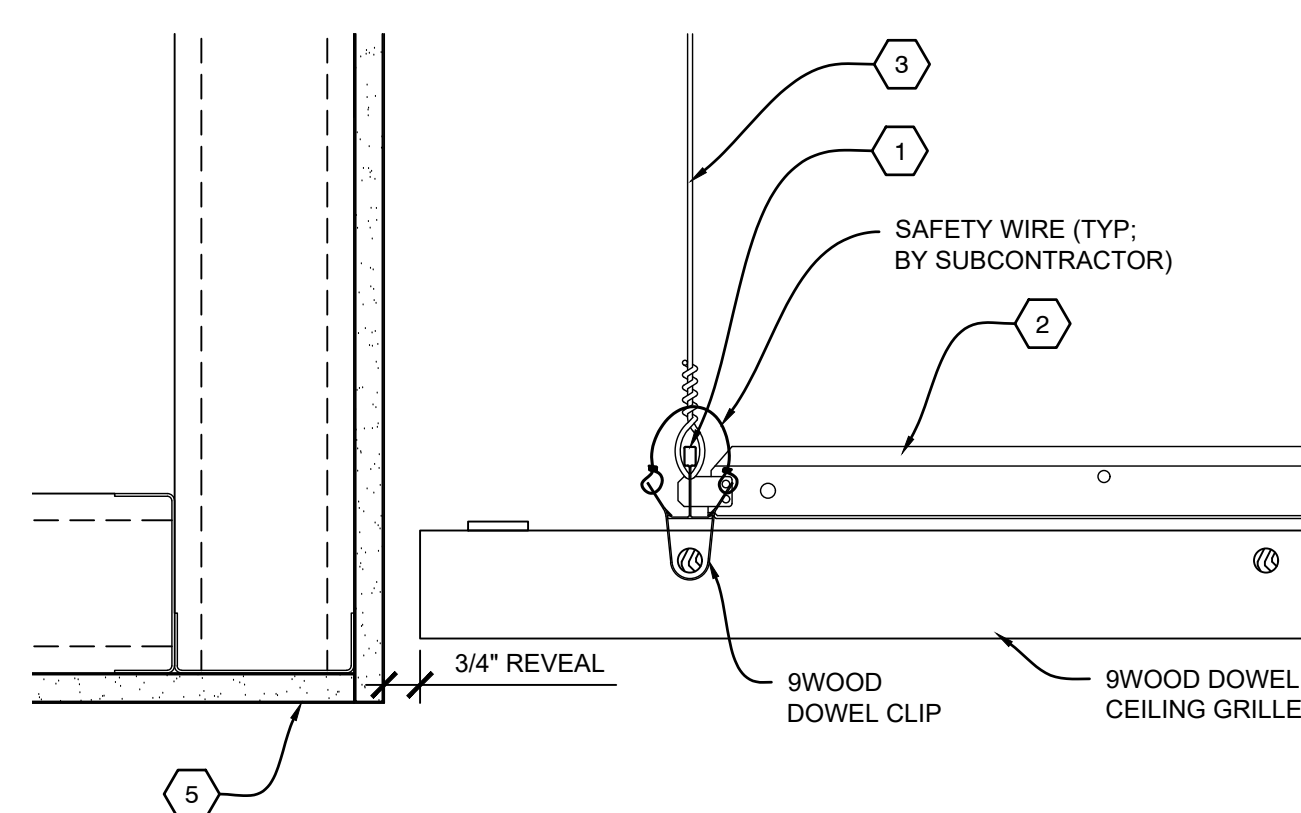

A2 SECTION - PERIMETER
SCALE: 1/4" = 1'

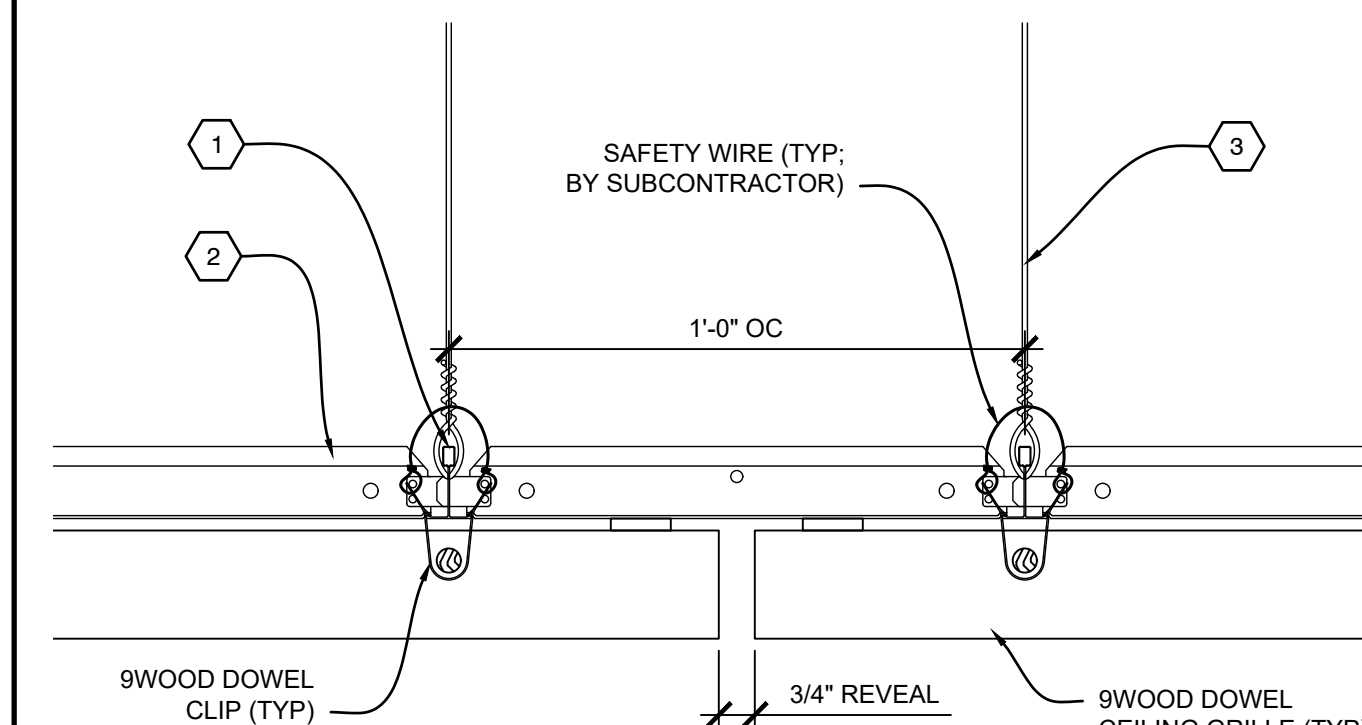

A3 SECTION - REVEAL
SCALE: 1/4" = 1'

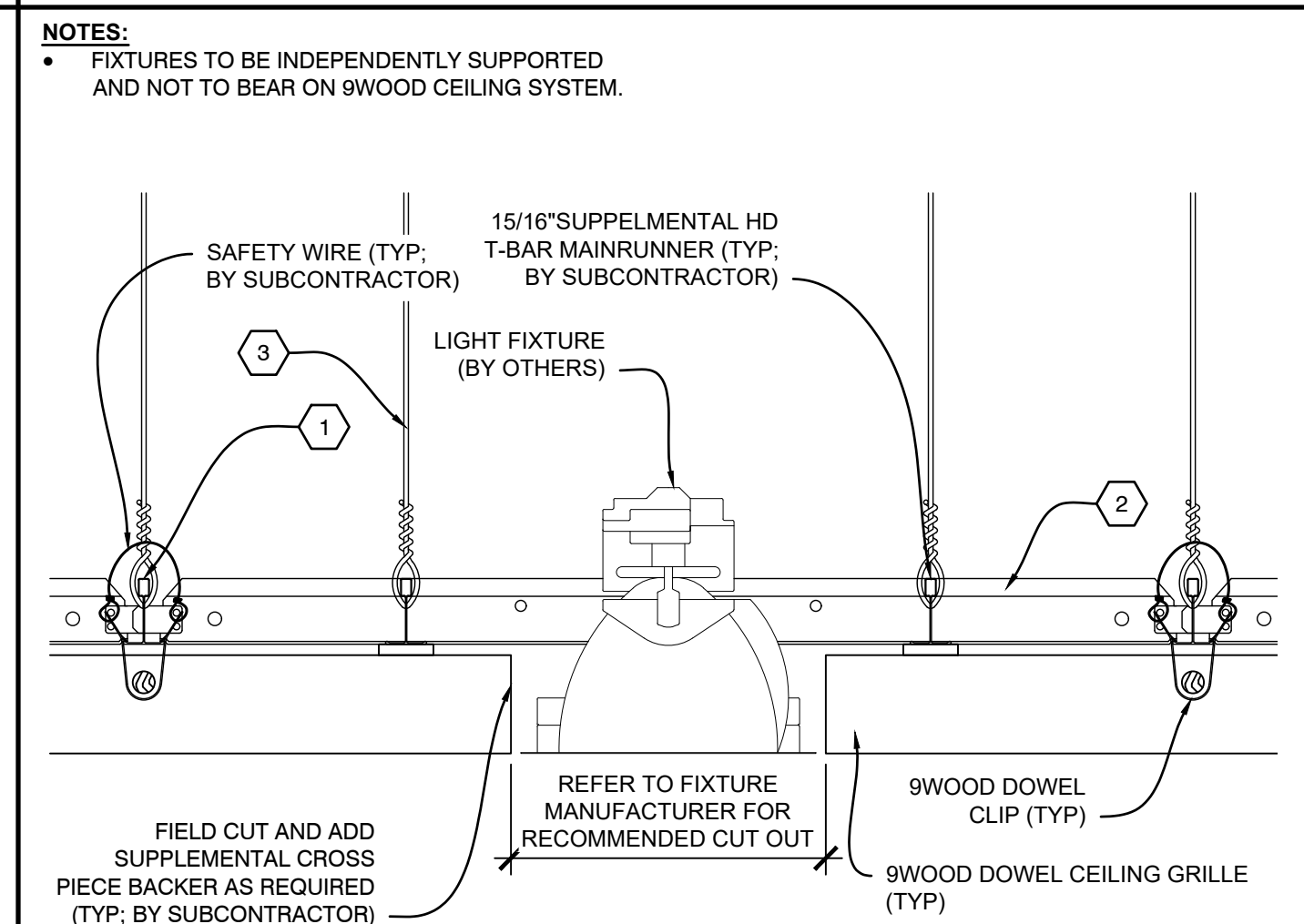

A4 SECTION - LIGHT FIXTURE
SCALE: 1/4" = 1'