

PROJECT CERTIFICATIONS: YES NO

PROJECT

PROJECT NUMBER:
PROPOSAL NUMBER:

REVISION HISTORY

REV#	DATE	DESCRIPTION
10		
9		
8		
7		
6		
5		
4		
3		
2		
1		
0	08.26.25	RELEASE FOR APPROVALS

SHEET INFORMATION

DRAWING TYPE: SHOP DRAWINGS
DRAWN BY: RAC
STANDARDS REVIEW: JBH
TECHNICAL REVIEW: JBH

THIS DOCUMENT CONTAINS PROPRIETARY INFORMATION OF 9WOOD, INC.
COPYRIGHT © 2025 9WOOD, INC.
ALL RIGHTS RESERVED.

KEY NOTES

- 1 15/16" HEAVY DUTY T-BAR MAIN RUNNER (TYP. BY SUBCONTRACTOR)
- 2 15/16" T-BAR CROSS TEE (TYP. BY SUBCONTRACTOR)
- 3 HANGER WIRE (TYP. BY SUBCONTRACTOR)
- 4 WALL ANGLE AND APPROPRIATE INSTALLATION FASTENER (TYP. BY SUBCONTRACTOR)
- 5 PERIMETER CONDITION (TYP. BY OTHERS)

SHEET TITLE

SYSTEM DETAILS

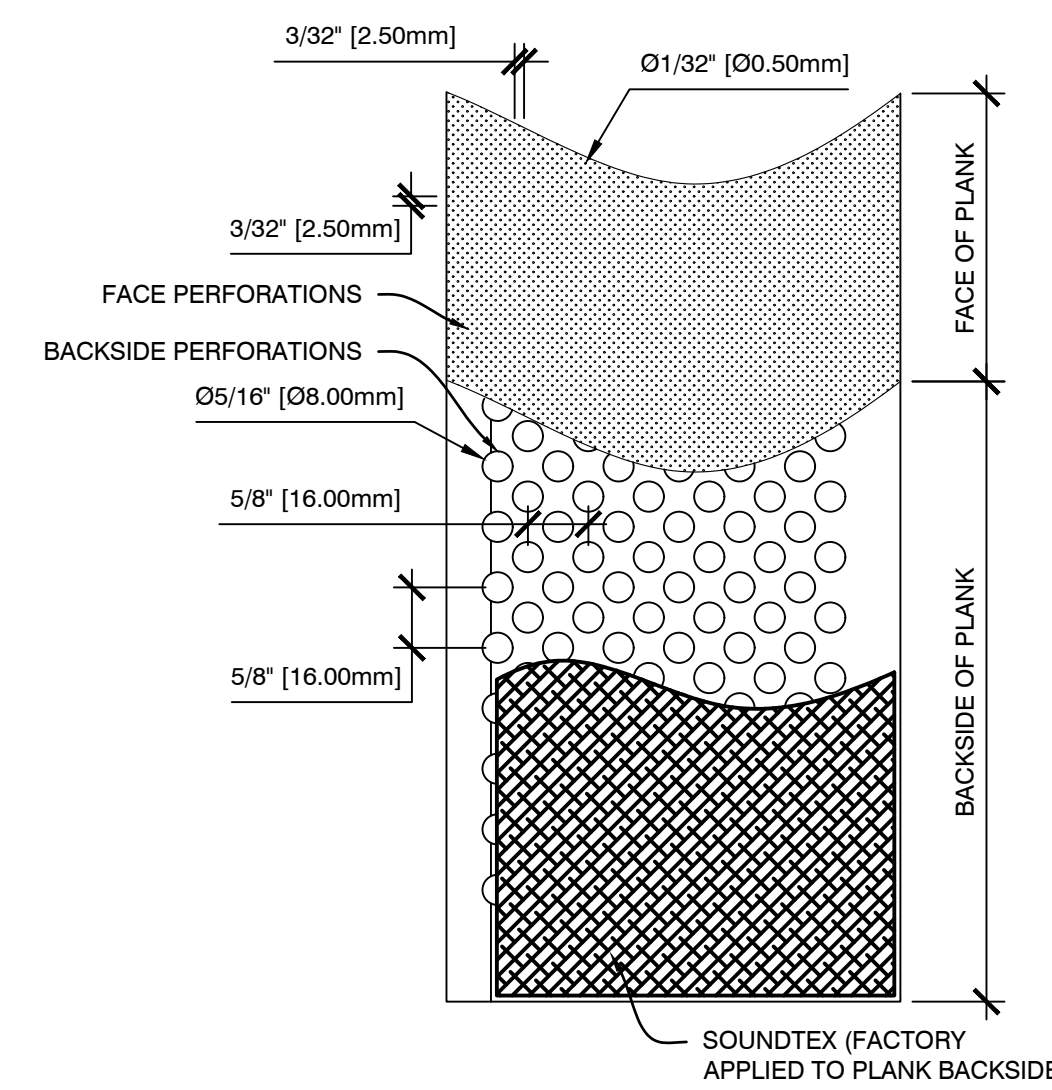

C2 FACE/PLAN VIEW -
NANOPERF PLANK

SCALE: 1/2" = 1" 0 1" 2" 3" 4"

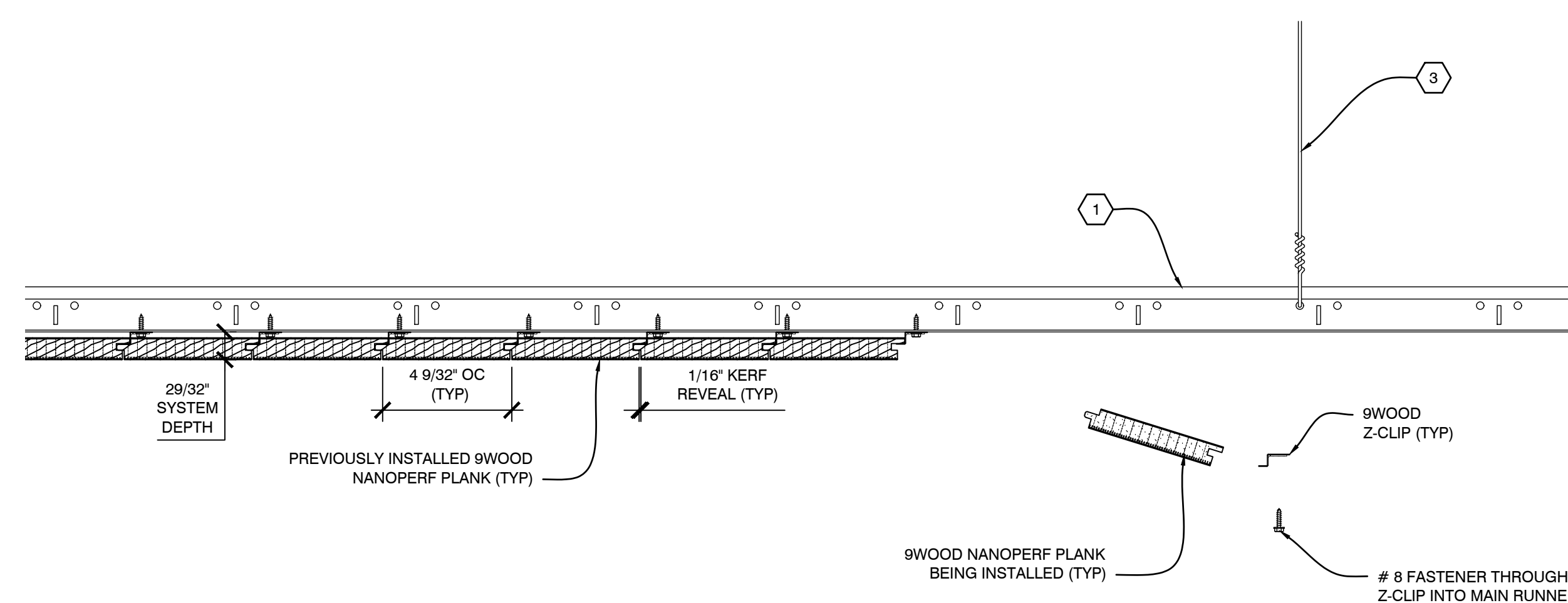

C3 INSTALLATION PROCESS - INSTALLATION PROCESS -
NANOPERF PLANK

SCALE: 1/4" = 1" 0 2" 4" 8"

NOTES:
• FIXTURES TO BE INDEPENDENTLY SUPPORTED AND NOT TO BEAR ON 9WOOD CEILING SYSTEM.

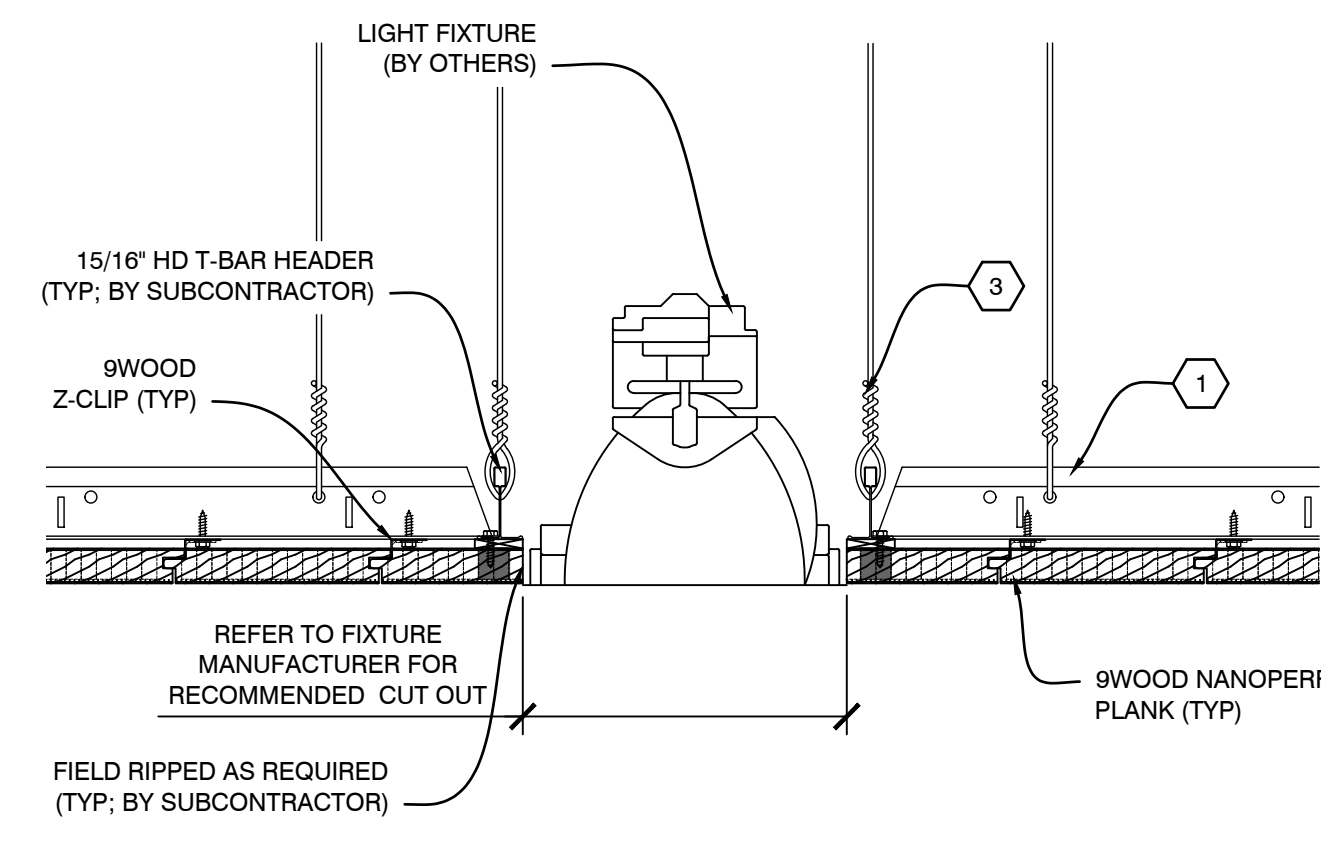

B2 SECTION - LIGHT FIXTURE

SCALE: 1/4" = 1" 0 2" 4" 8"

NOTES:
• FIXTURES TO BE INDEPENDENTLY SUPPORTED AND NOT TO BEAR ON 9WOOD CEILING SYSTEM.

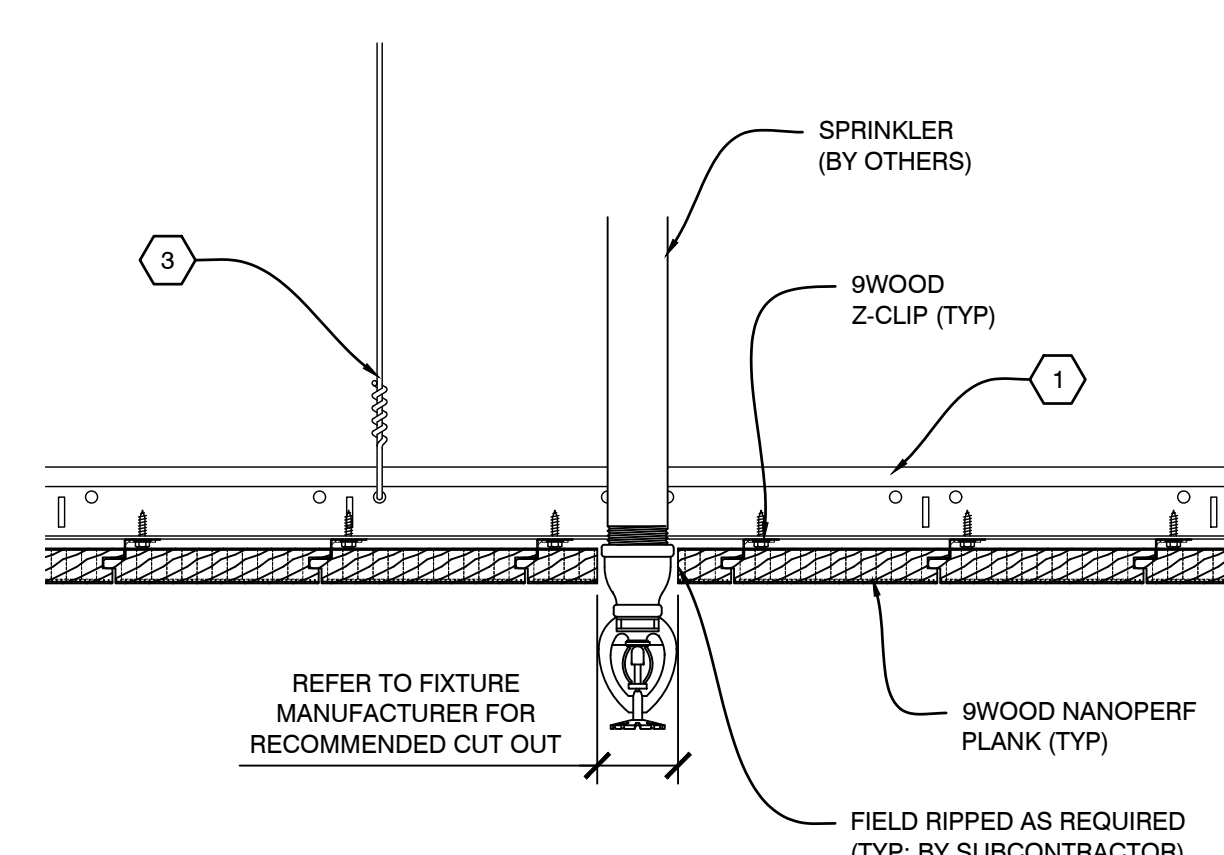

B3 SECTION - SPRINKLER

SCALE: 1/4" = 1" 0 2" 4" 8"

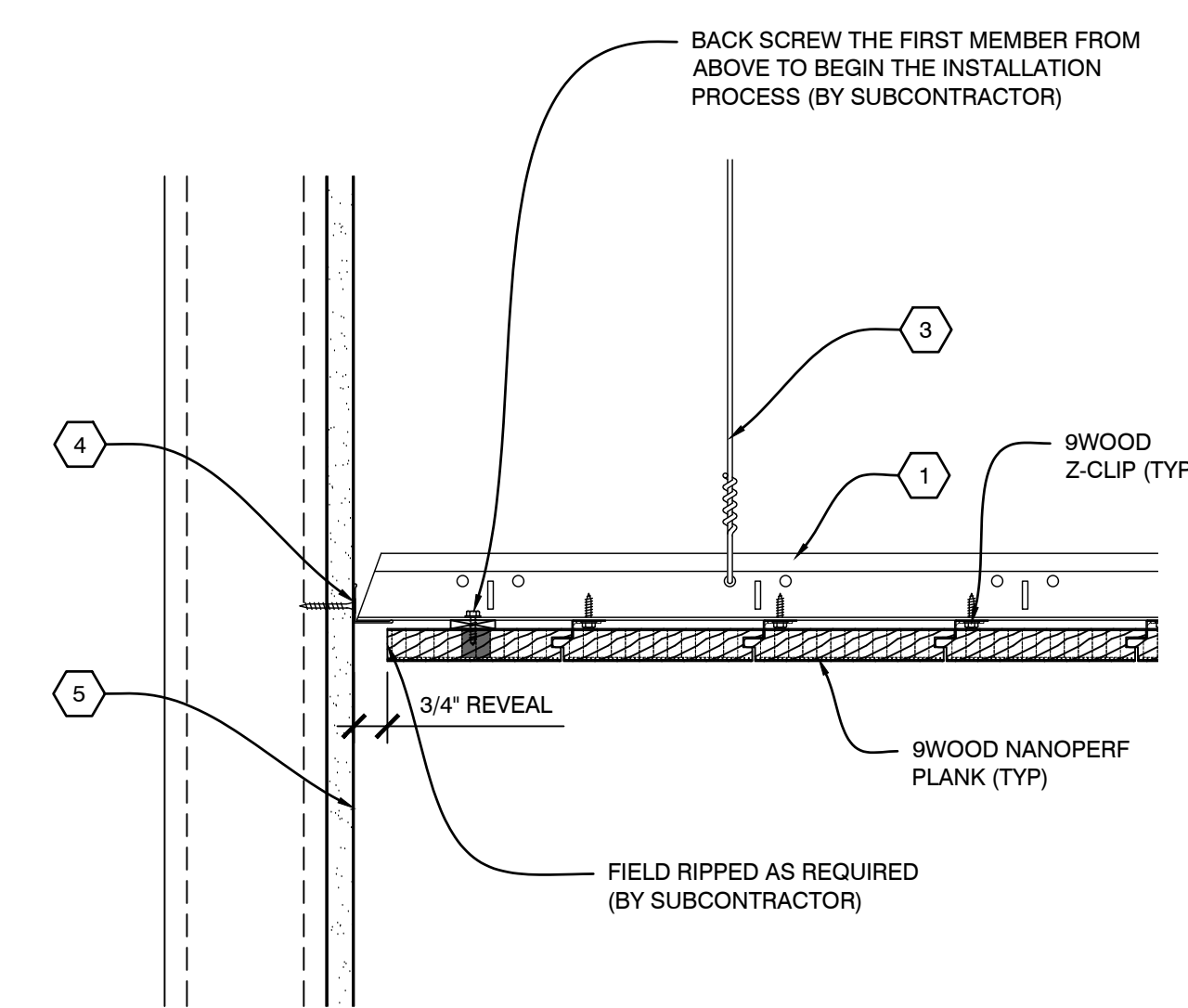

B1 SECTION - PERIMETER

SCALE: 1/4" = 1" 0 2" 4" 8"

NOTES:
• FIXTURES TO BE INDEPENDENTLY SUPPORTED AND NOT TO BEAR ON 9WOOD CEILING SYSTEM.

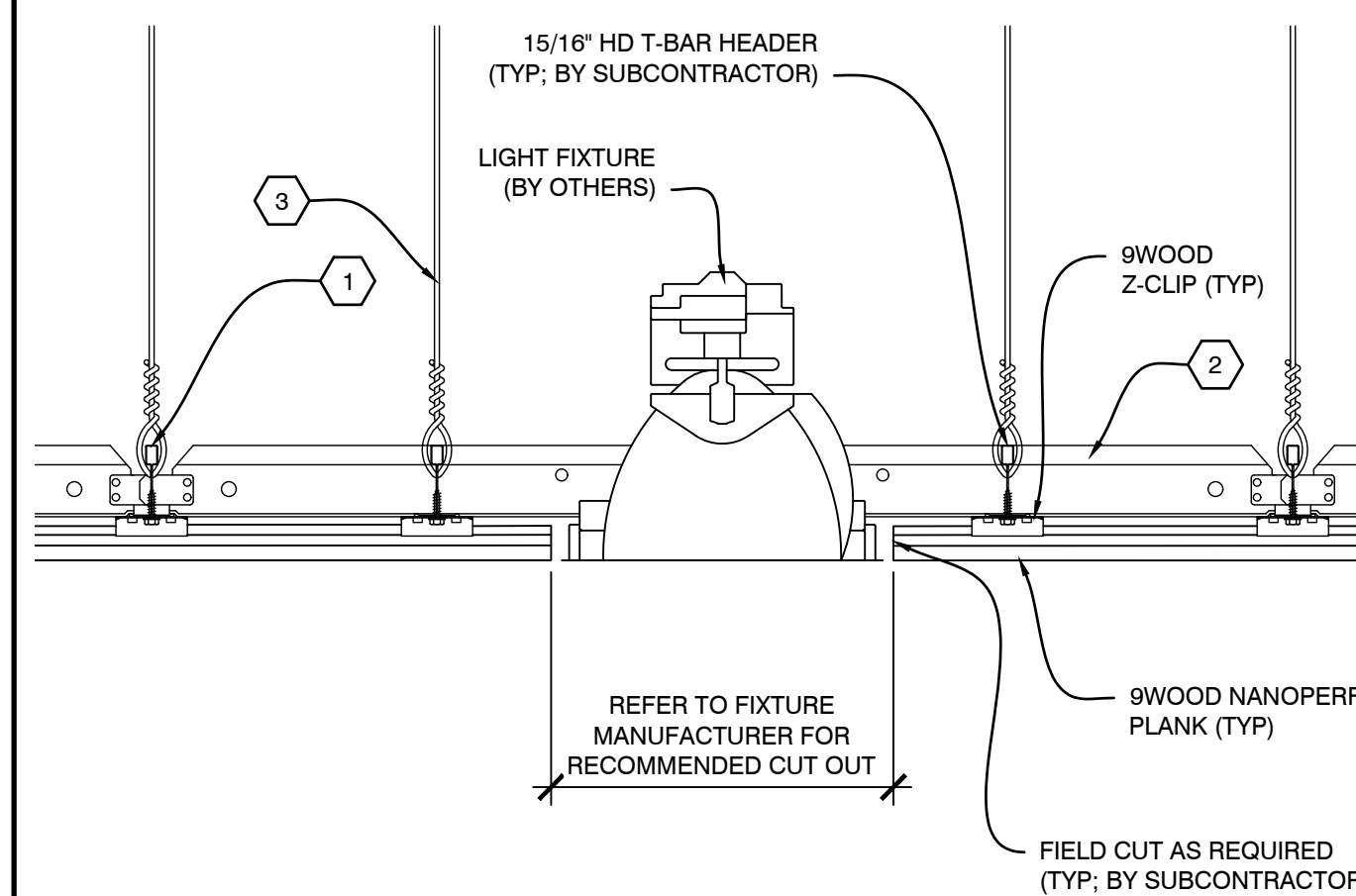

A3 SECTION - LIGHT FIXTURE

SCALE: 1/4" = 1" 0 2" 4" 8"

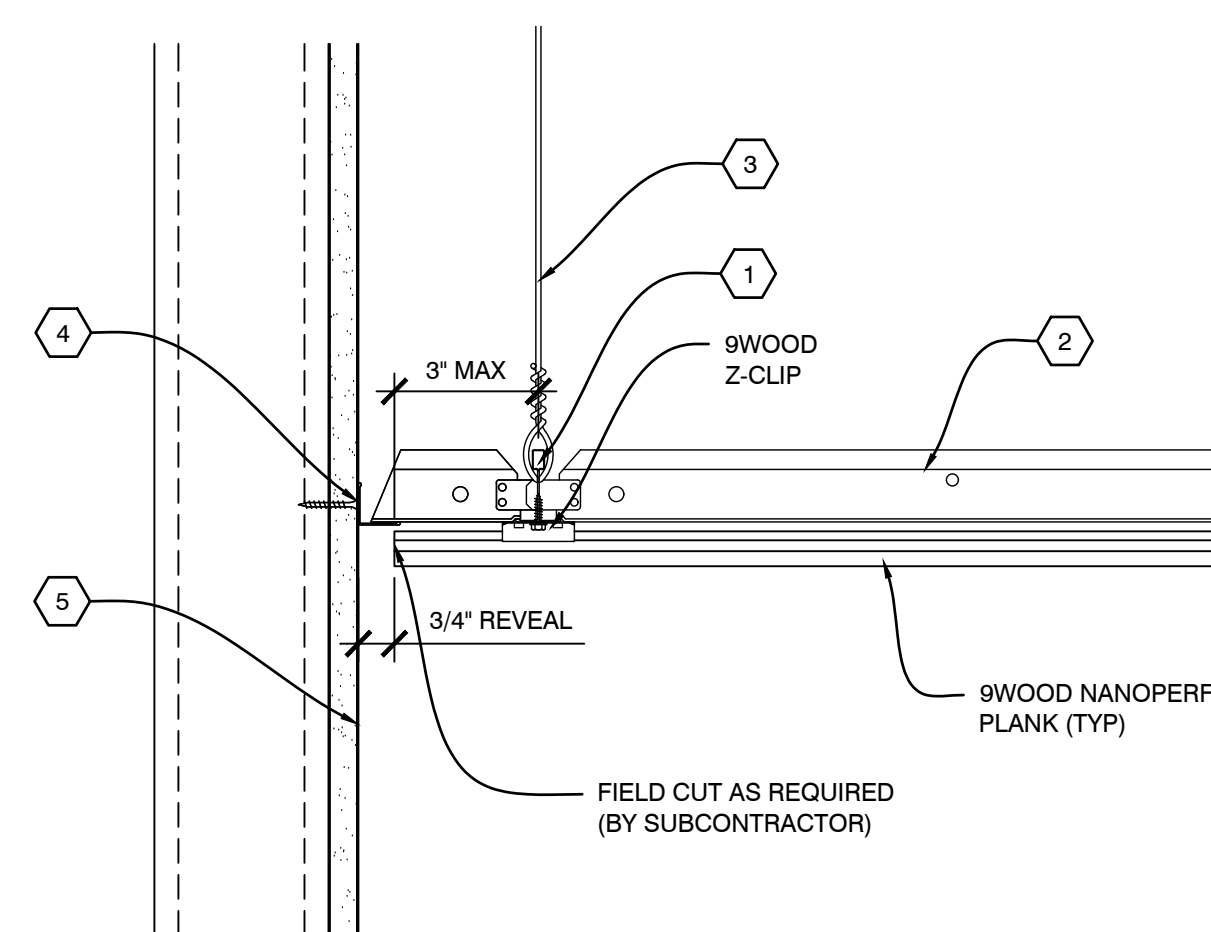

A2 SECTION - PERIMETER

SCALE: 1/4" = 1" 0 2" 4" 8"

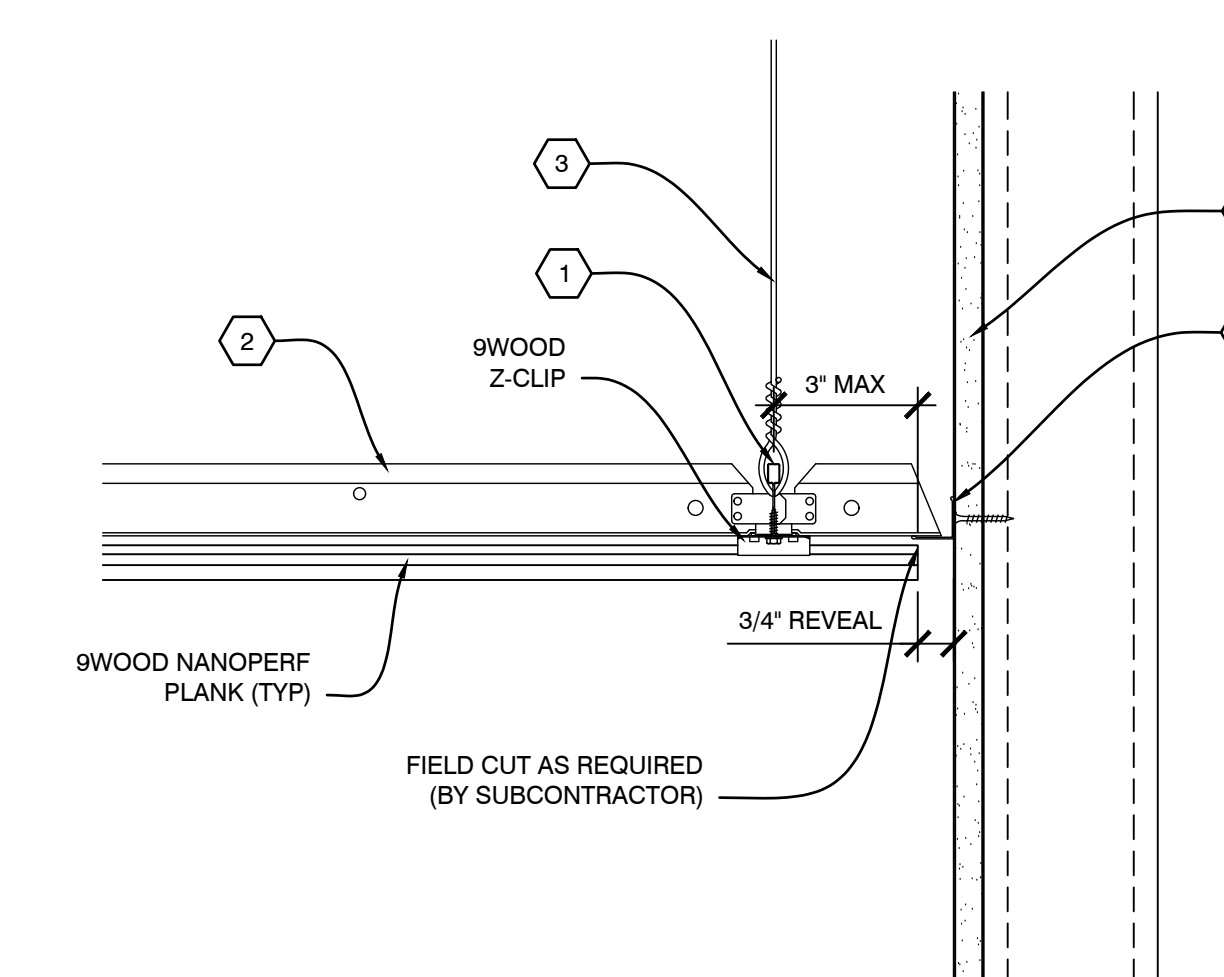

A4 SECTION - PERIMETER

SCALE: 1/4" = 1" 0 2" 4" 8"

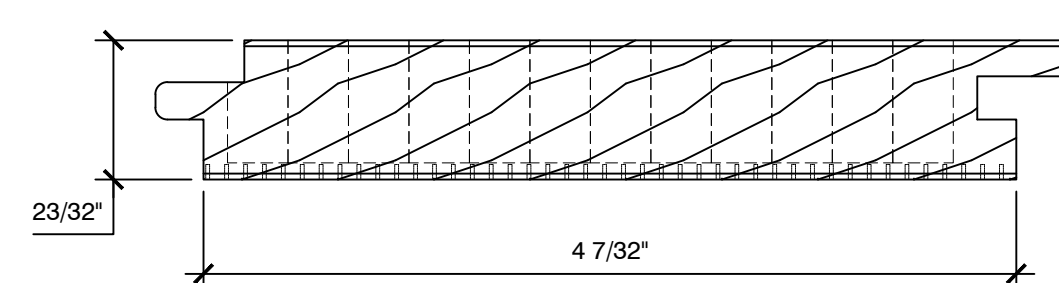

A1 SECTION - NANOPERF PLANK

SCALE: 1" = 1" 0 1" 2"