

PROJECT

PROJECT NUMBER:  
PROPOSAL NUMBER:

REVISION HISTORY

REV#	DATE	DESCRIPTION
10		
9		
8		
7		
6		
5		
4		
3		
2		
1		
0	07.17.25	RELEASE FOR APPROVALS

SHEET INFORMATION

DRAWING TYPE: SHOP DRAWINGS  
DRAWN BY: DMS  
STANDARDS REVIEW: RAC  
TECHNICAL REVIEW: RAC

THIS DOCUMENT CONTAINS PROPRIETARY INFORMATION OF 9WOOD, INC.  
COPYRIGHT © 2025 9WOOD, INC.  
ALL RIGHTS RESERVED.

KEY NOTES

- 1 15/16" HEAVY DUTY T-BAR MAIN RUNNER (TYP. BY SUBCONTRACTOR)
- 2 15/16" T-BAR CROSS TEE (TYP. BY SUBCONTRACTOR)
- 3 HANGER WIRE (TYP. BY SUBCONTRACTOR)
- 4 WALL ANGLE AND APPROPRIATE INSTALLATION FASTENER (TYP. BY SUBCONTRACTOR)
- 5 PERIMETER CONDITION (TYP. BY OTHERS)
- 6 9WOOD ALIGNMENT BRACKET (TYP. FACTORY INSTALLED)
- 7 9WOOD TRUE ACCESS CLIP ASSEMBLY (TYP. FACTORY INSTALLED)

SHEET TITLE

## SYSTEM DETAILS

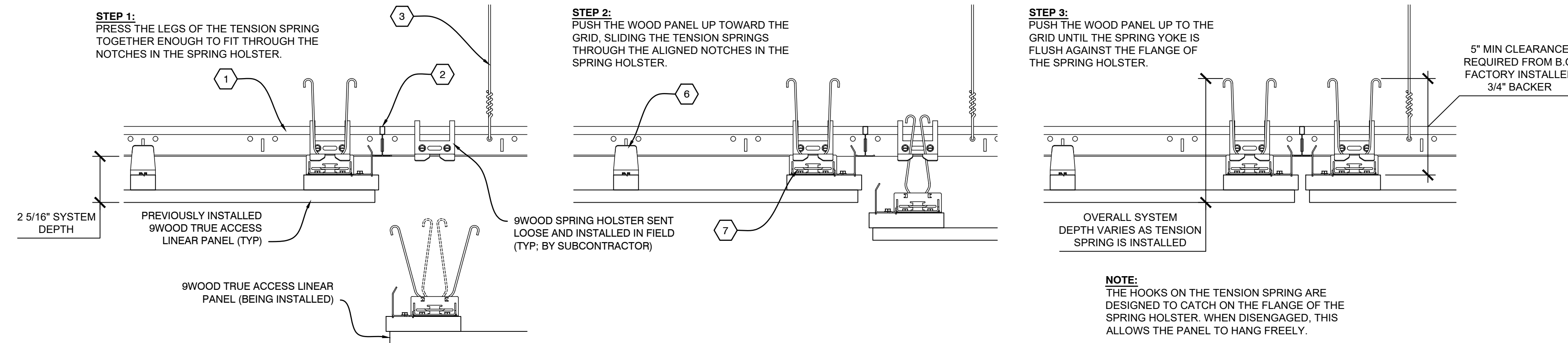

**D2** INSTALLATION PROCESS - TRUE ACCESS LINEAR CEILING PANEL  
SCALE: 1/4" = 1"

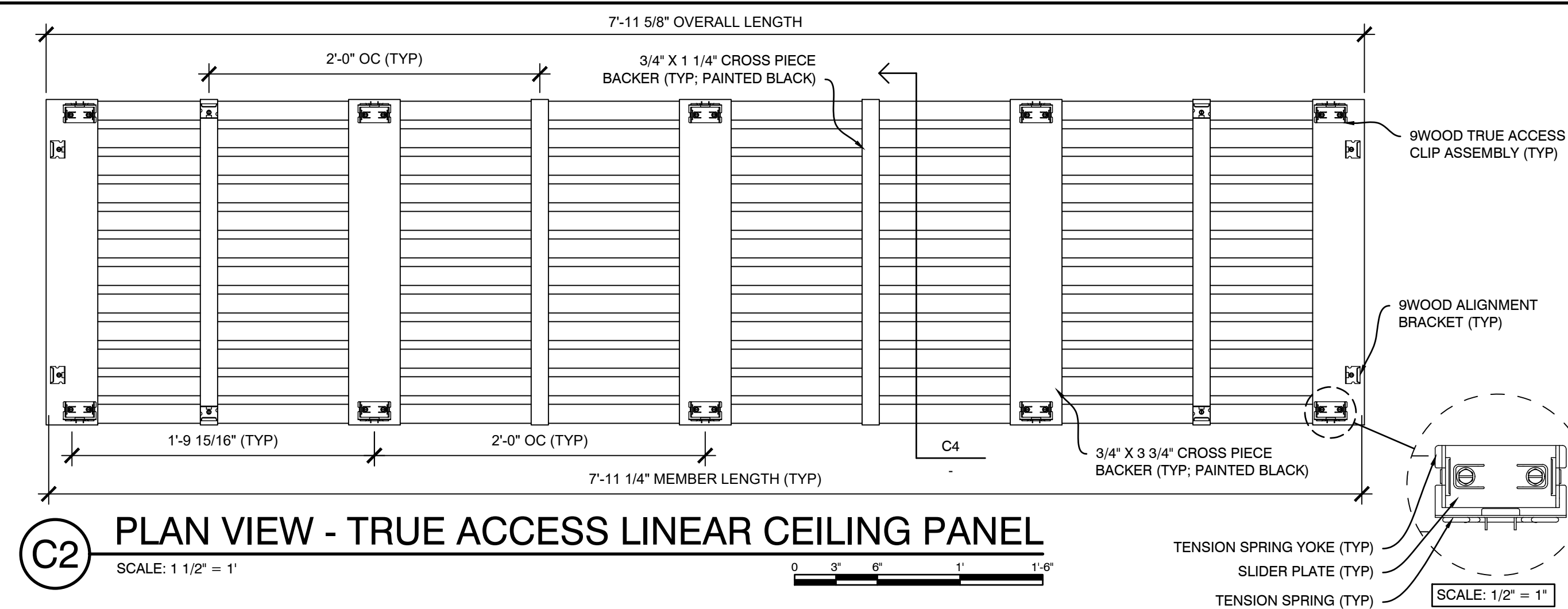

**C2** PLAN VIEW - TRUE ACCESS LINEAR CEILING PANEL  
SCALE: 1/2" = 1"

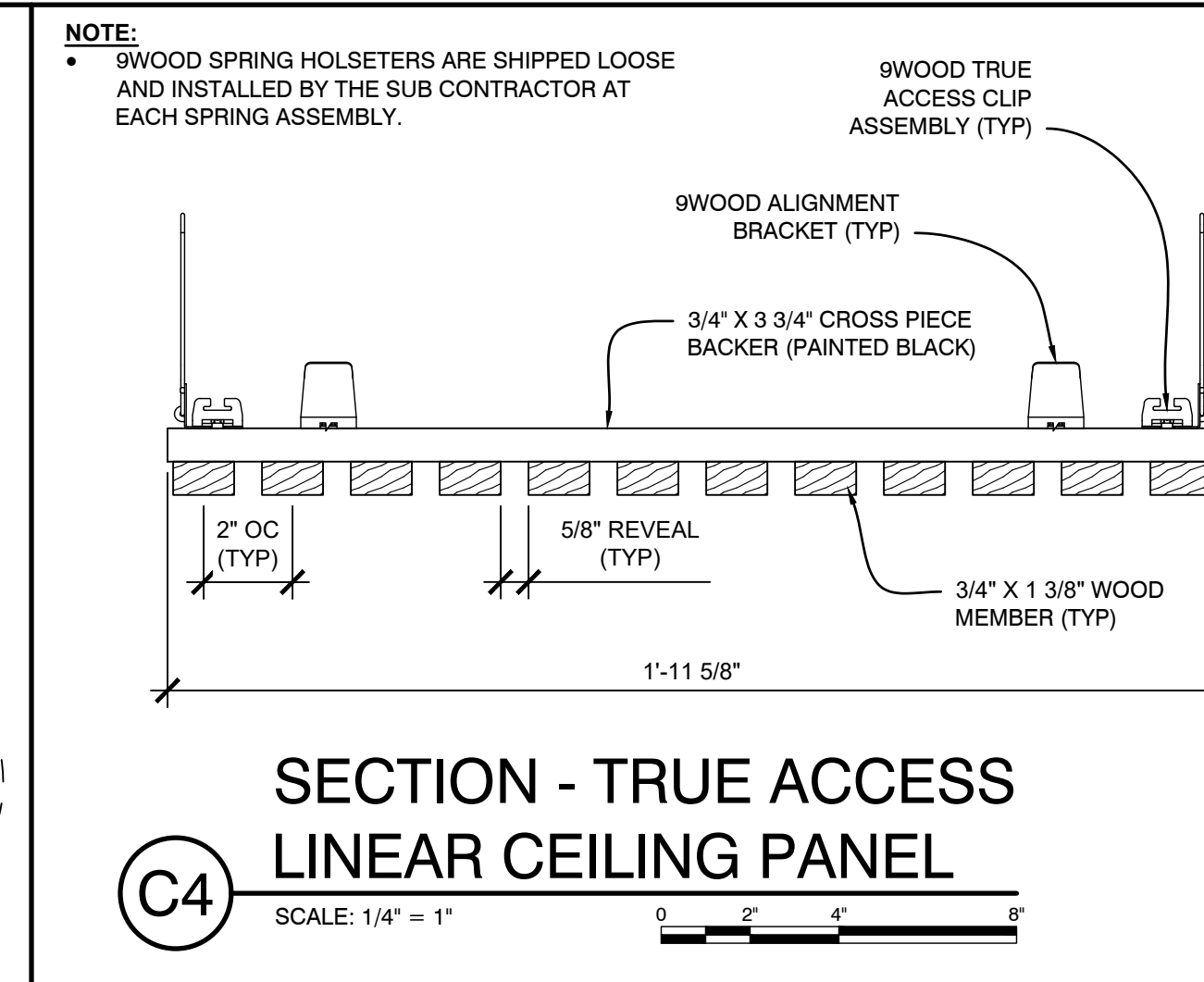

**C4** SECTION - TRUE ACCESS LINEAR CEILING PANEL  
SCALE: 1/4" = 1"

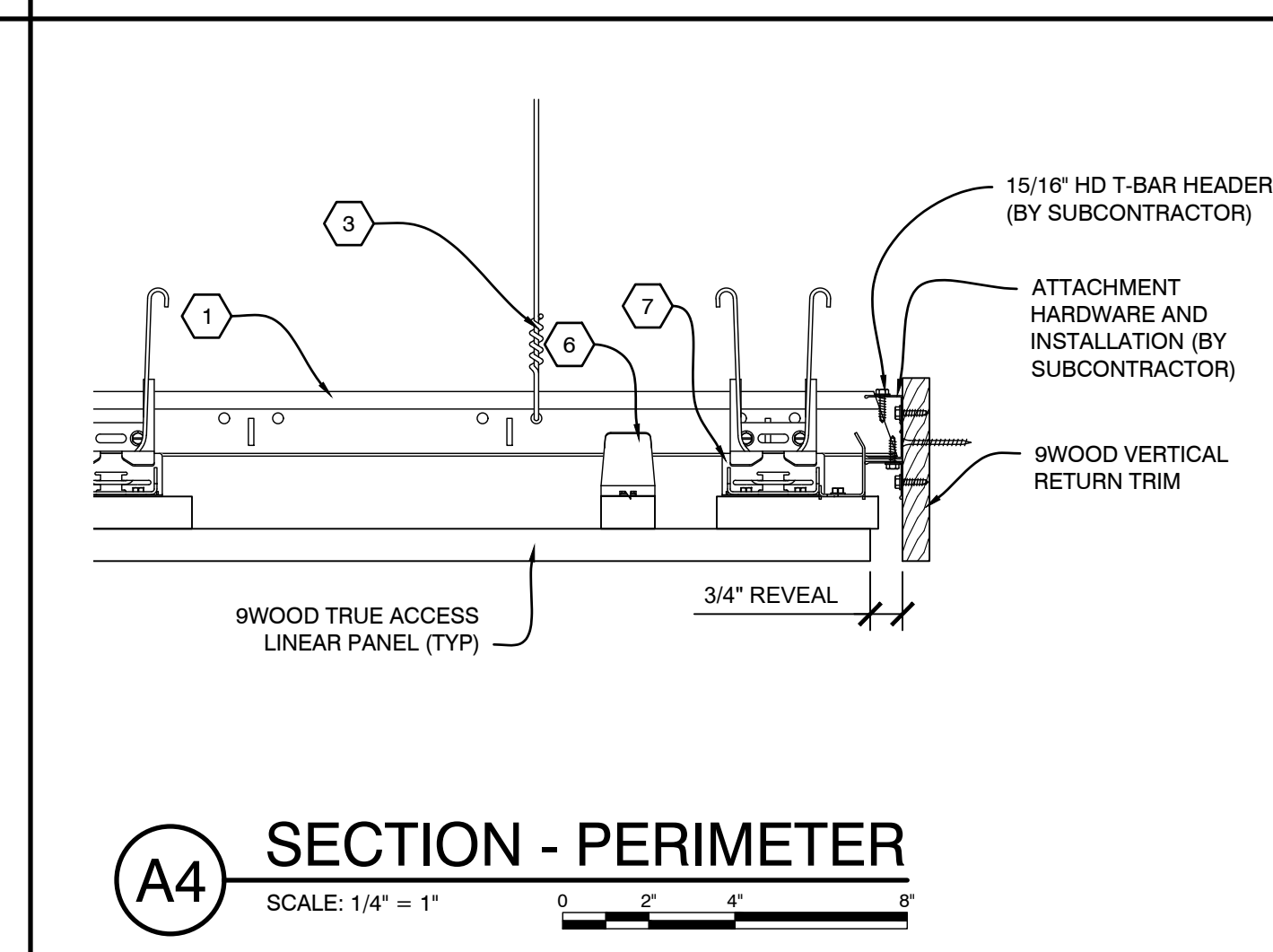
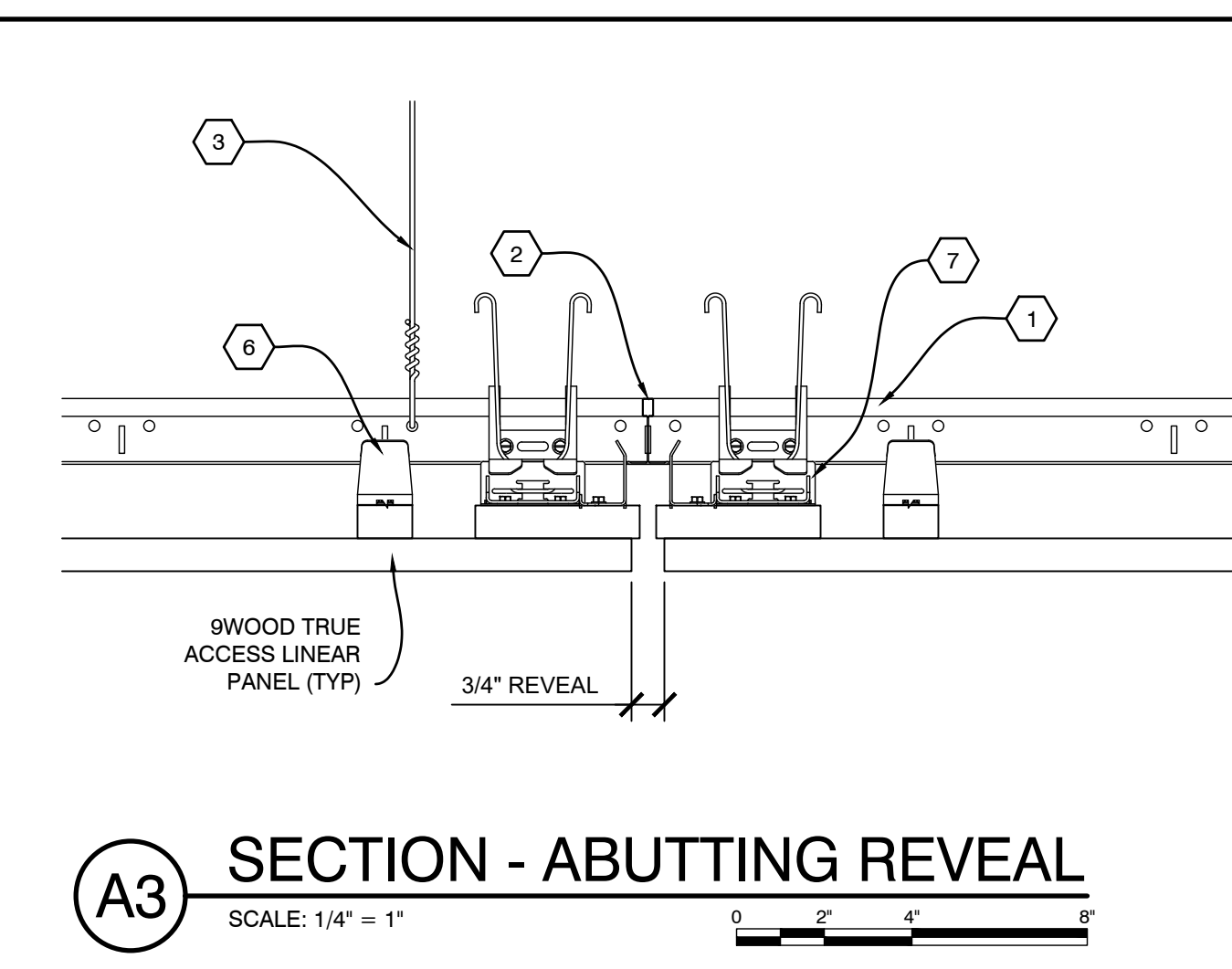
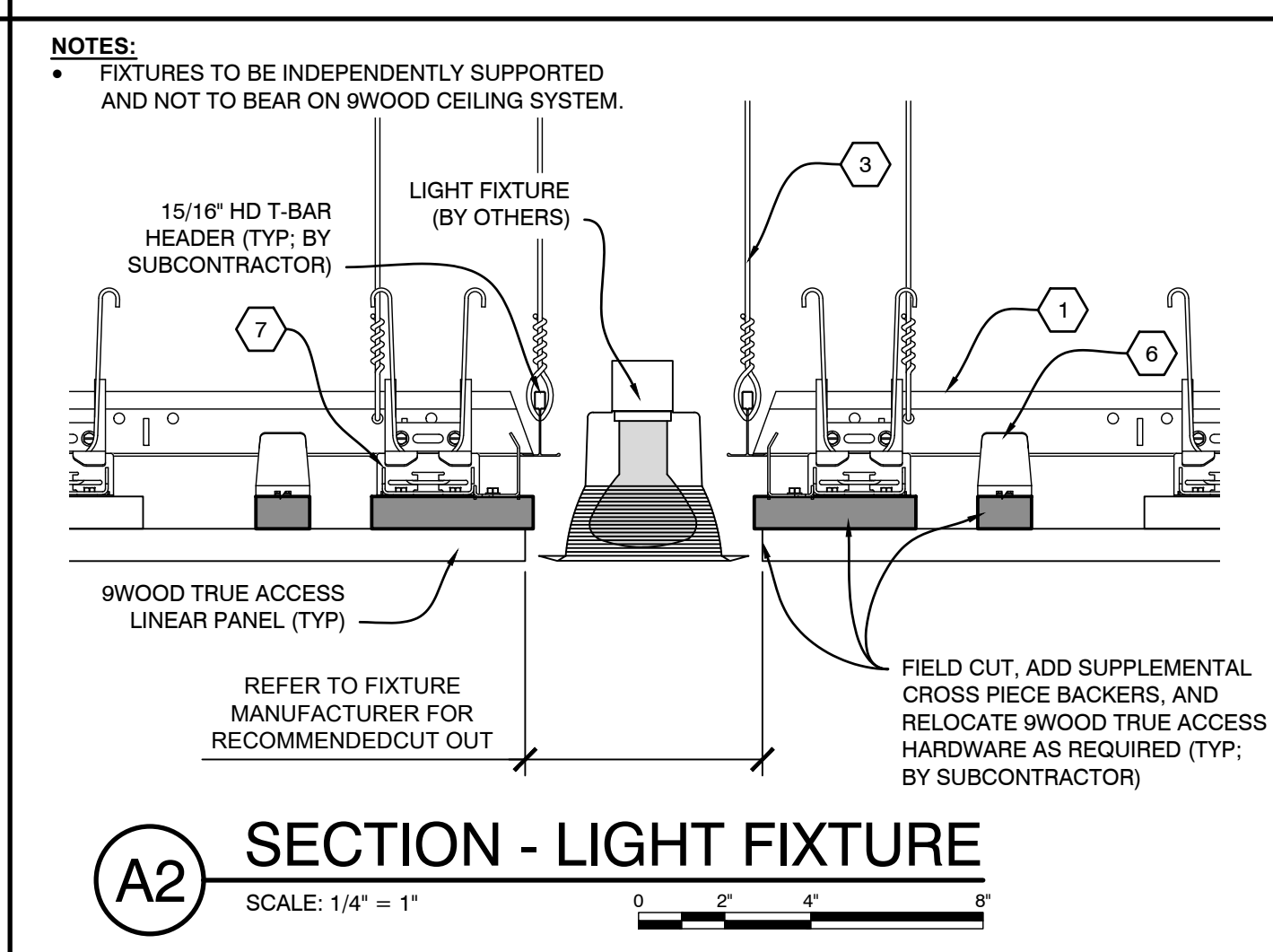
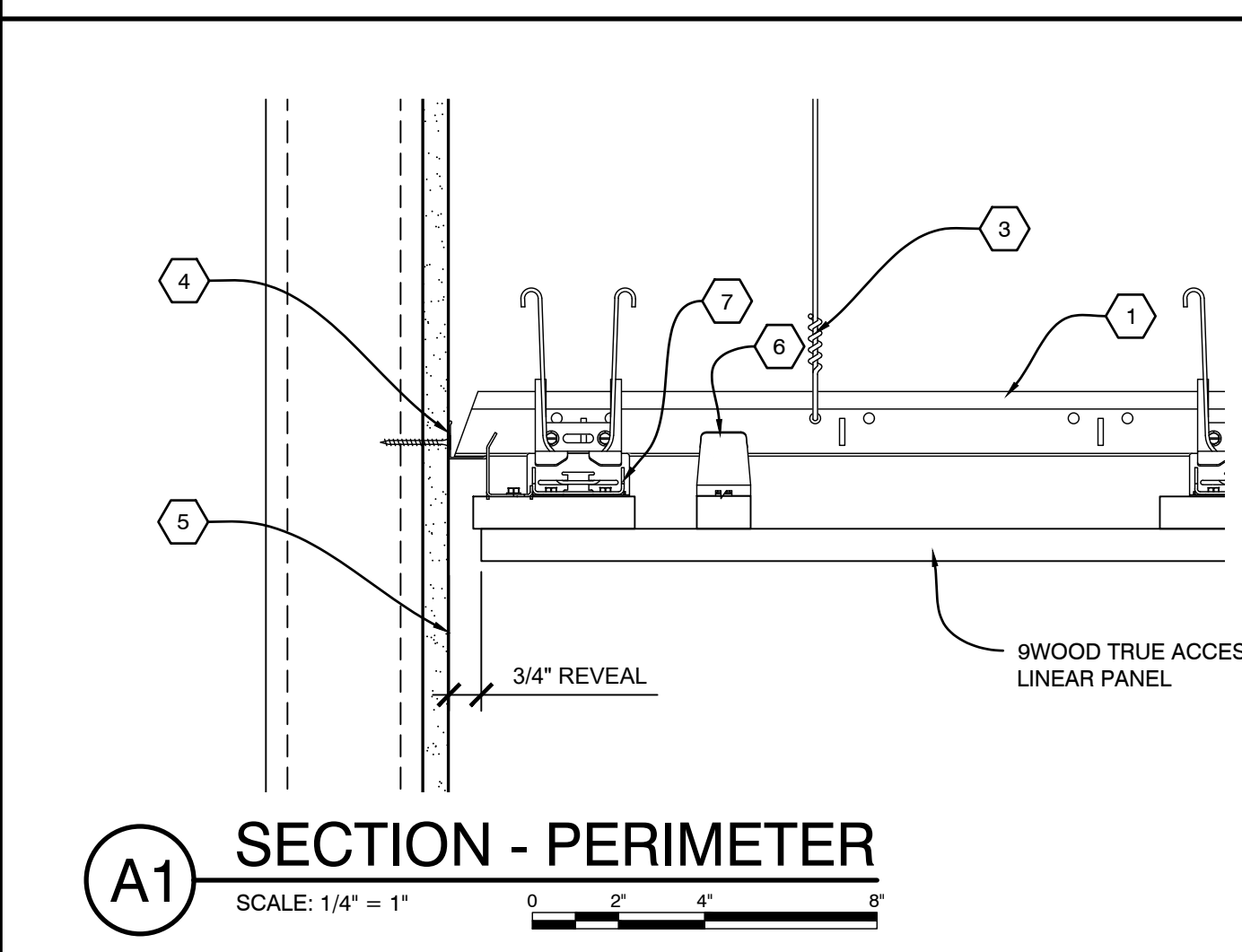
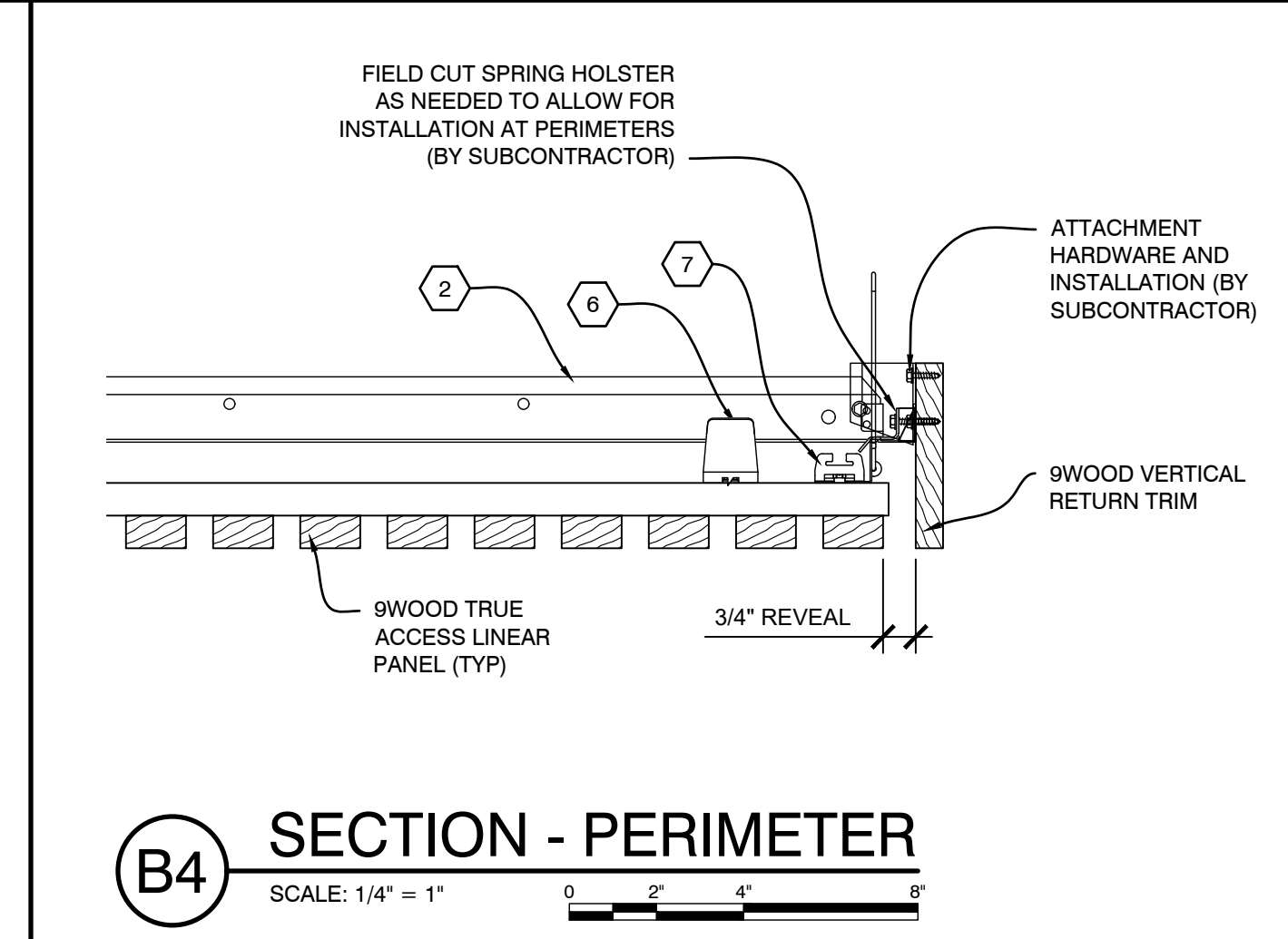
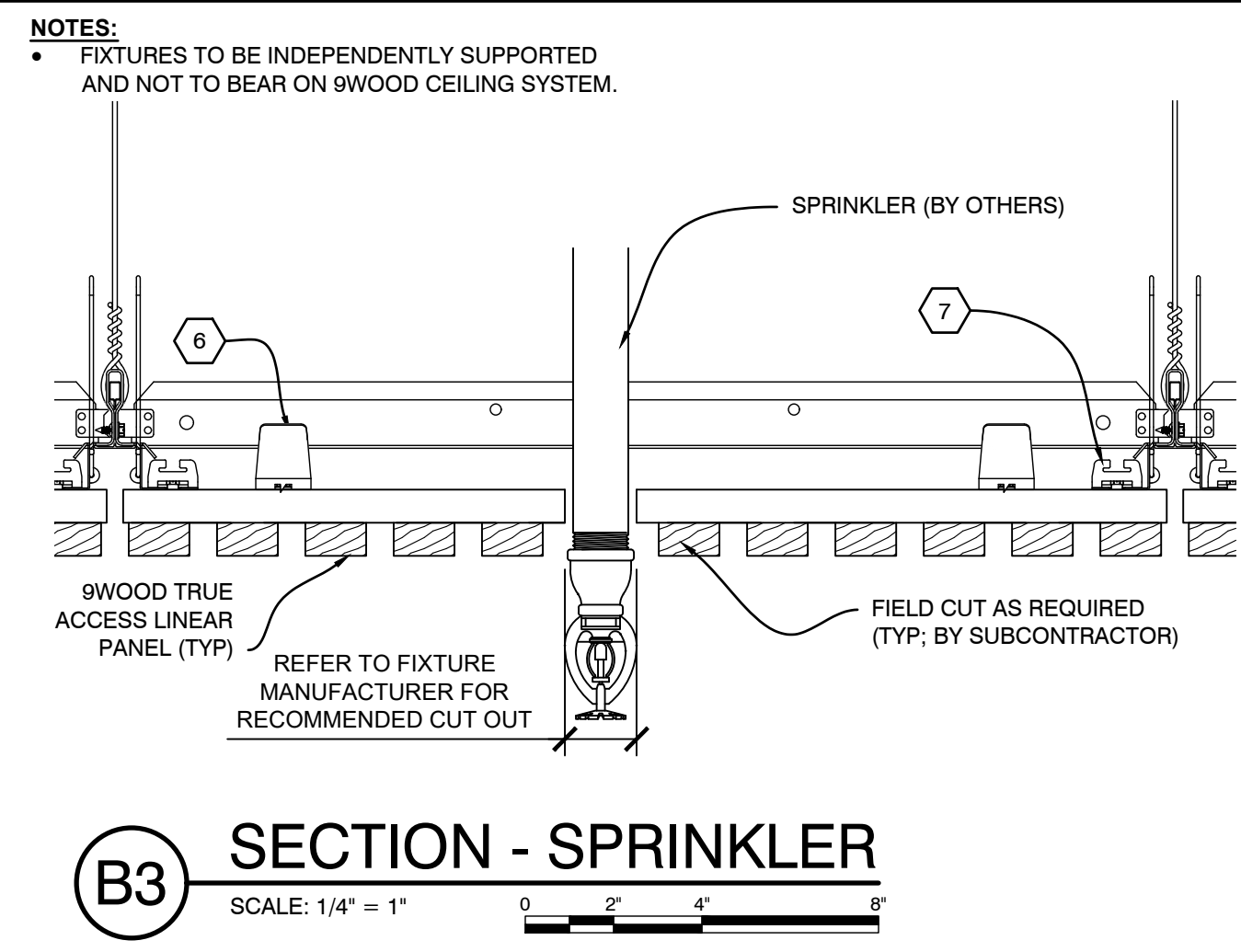
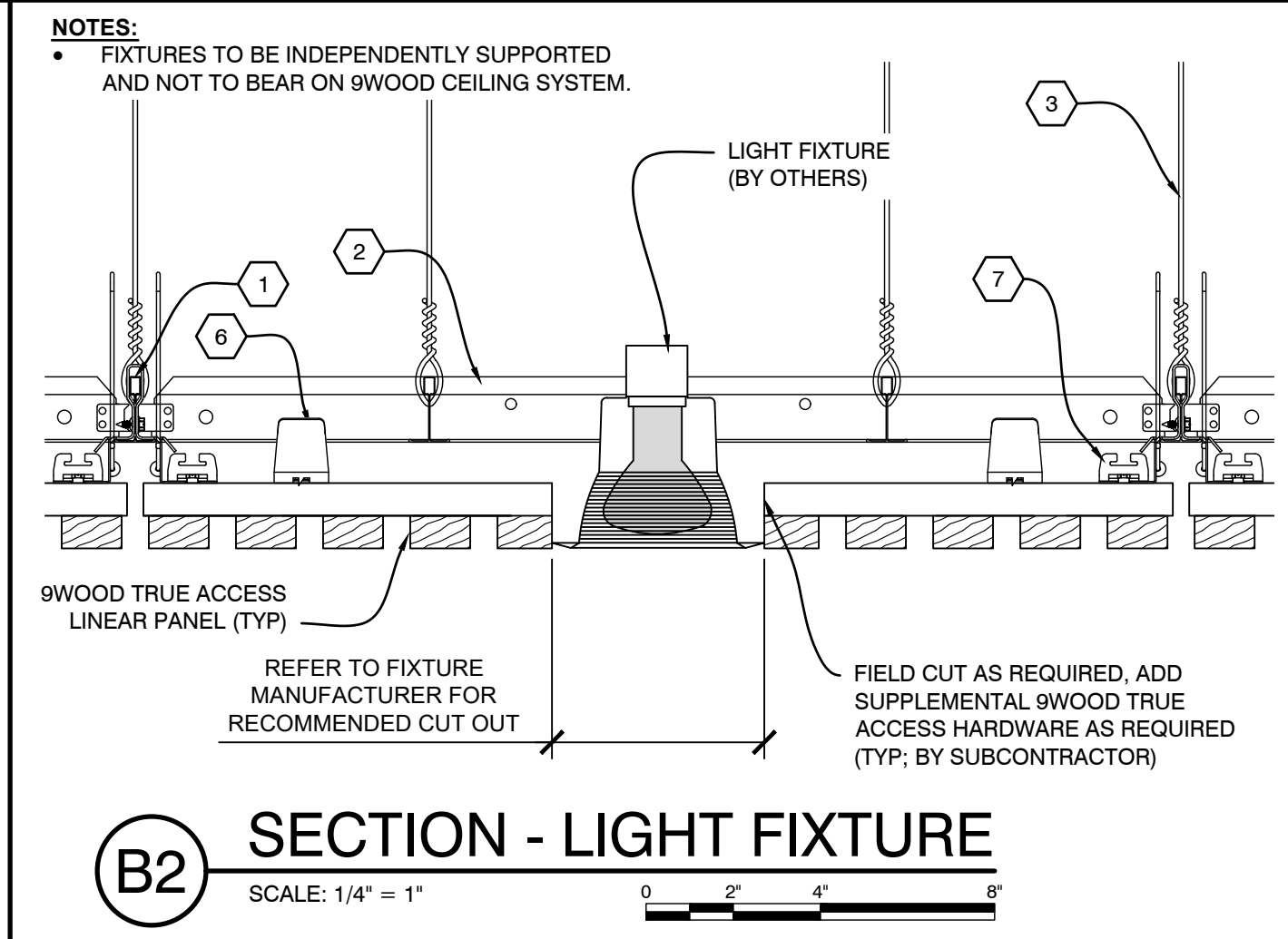
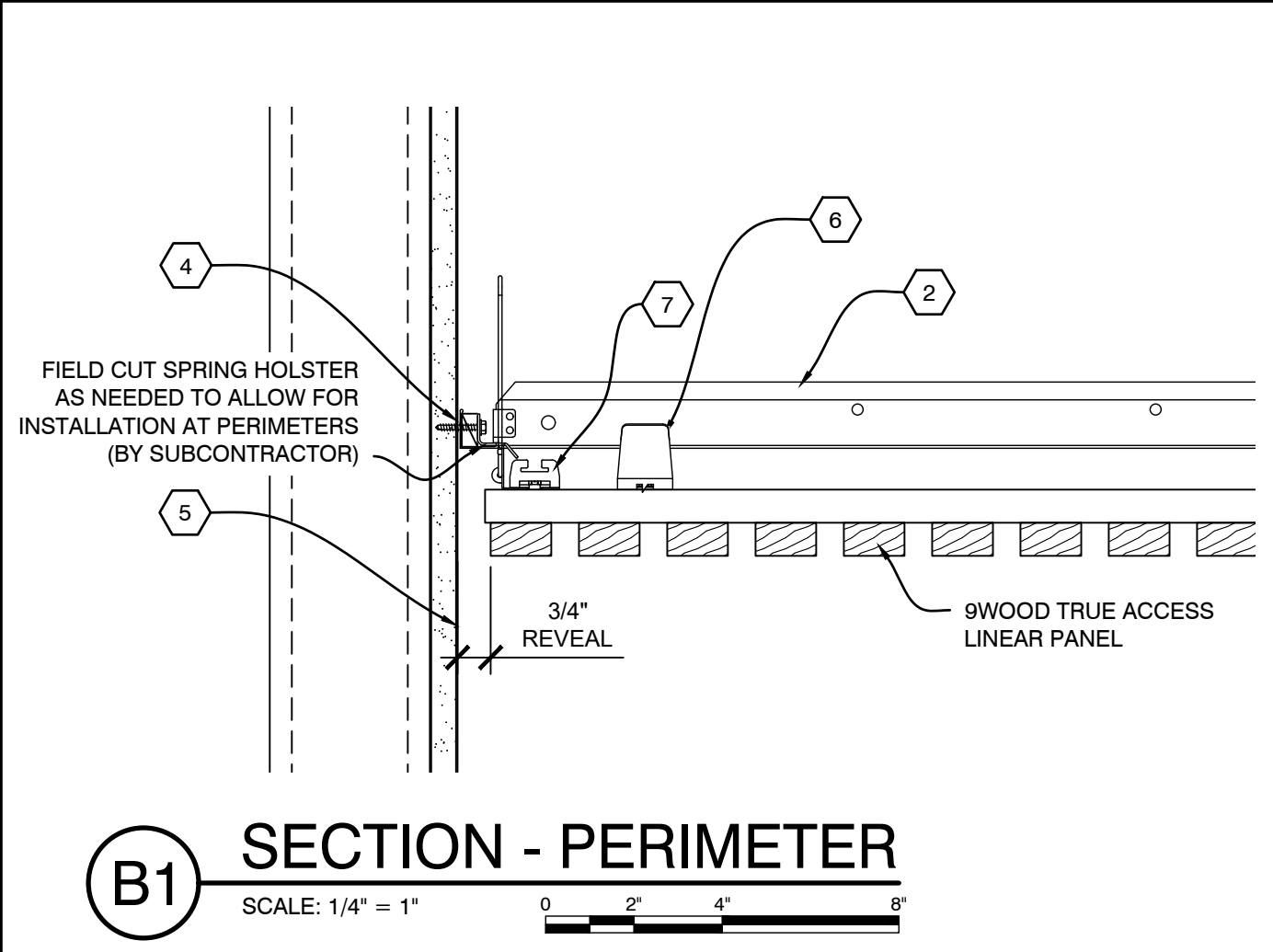

9WOOD TRUE ACCESS LINEAR CEILING PANEL SYSTEM DRAWING 2025-07-17 11:18:11 AM  
 DRAWN BY: DMS  
 CHECKED BY: RAC  
 DATE PLOTTED: 7/17/25 11:18:11 AM

