

**D3** PLAN VIEW - CROSS PIECE BACKER WOOD GRILLE  
SCALE: 1 1/2" = 1'

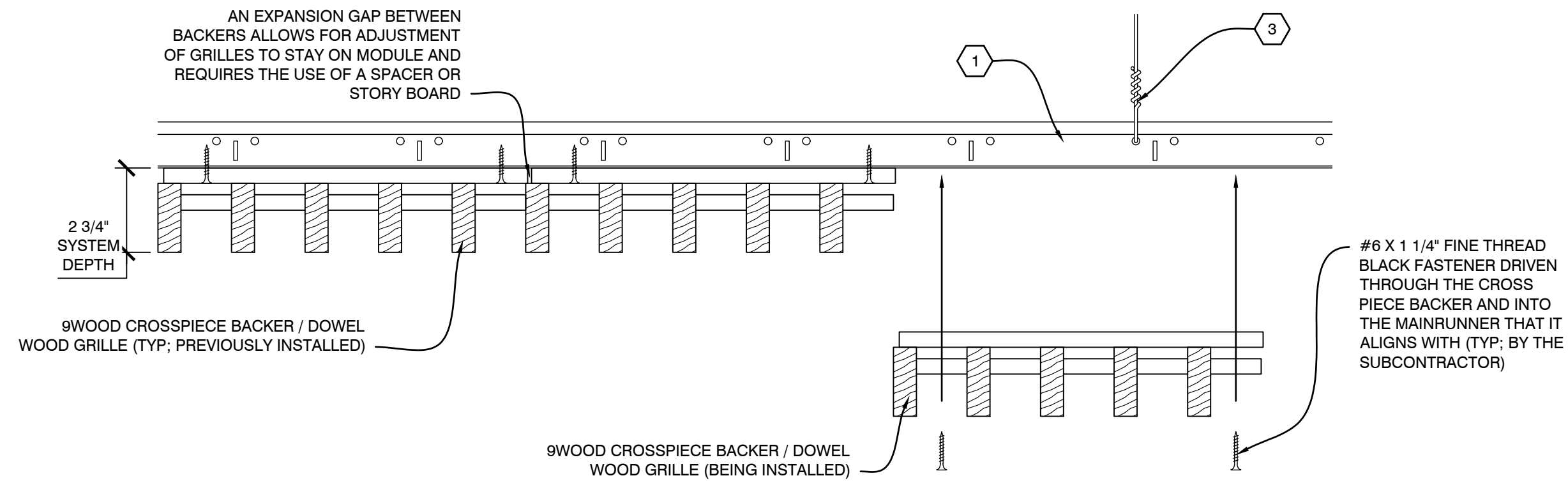

**C1** INSTALLATION PROCESS - CROSS PIECE BACKER WOOD GRILLE  
SCALE: 1/4" = 1'

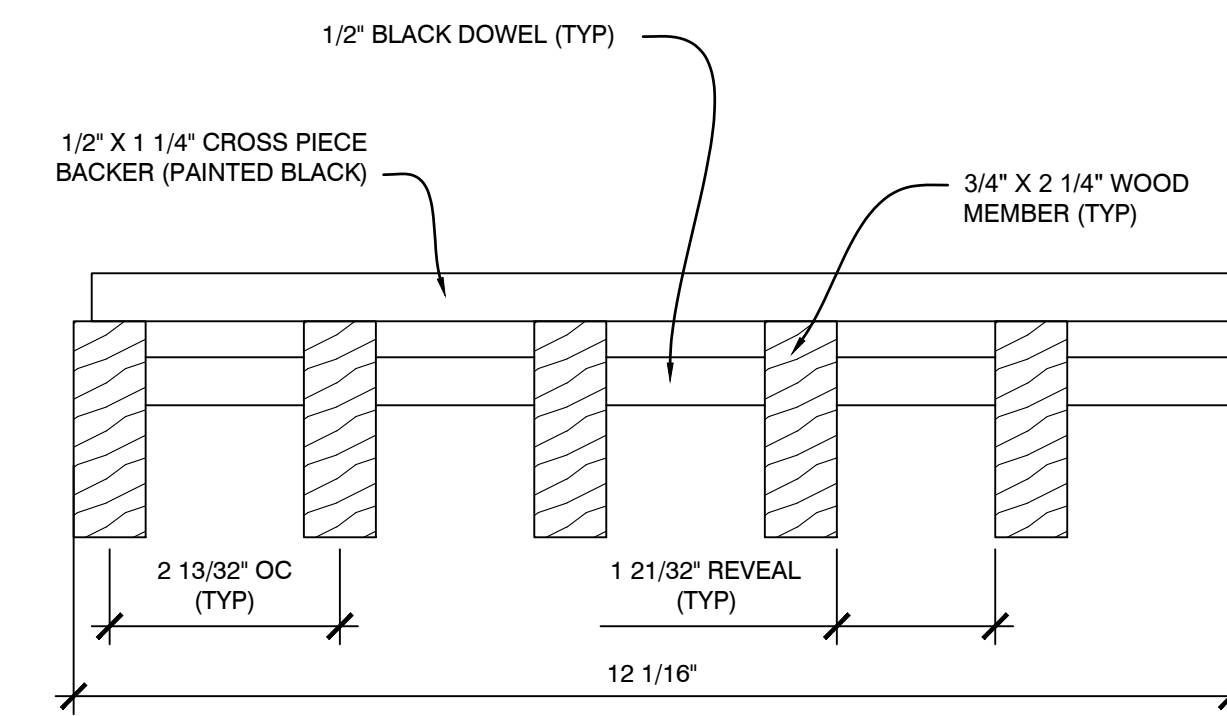

**C3** SECTION - CROSS PIECE BACKER WOOD GRILLE  
SCALE: 1/2" = 1'

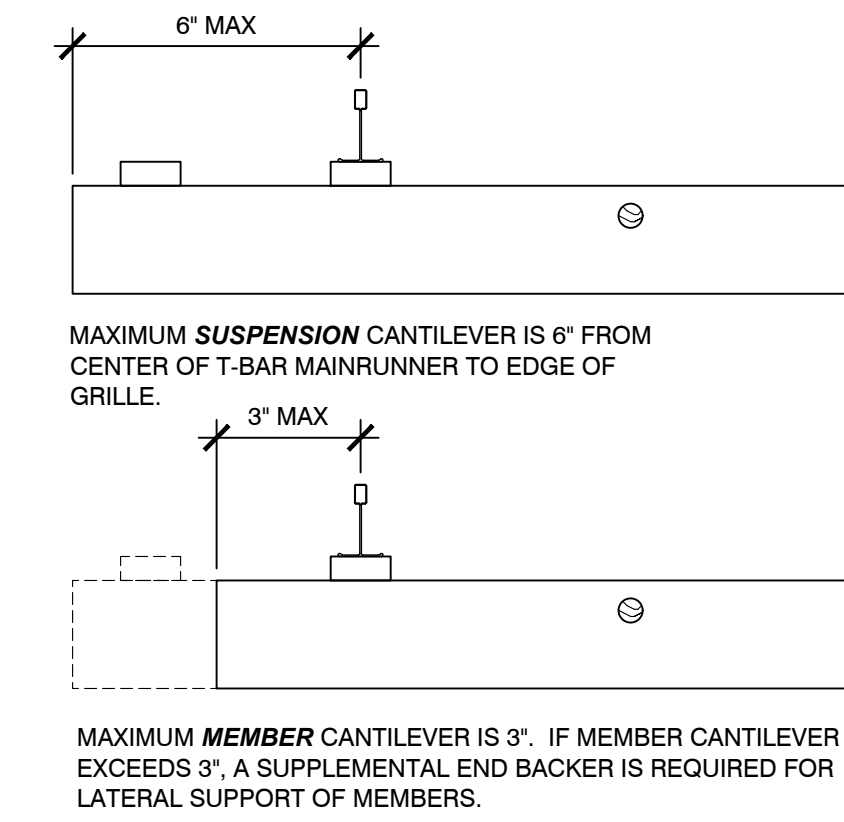

**C4** SECTION - CANTILEVER RULES  
SCALE: 1/4" = 1'

PROJECT  
**9WOOD**  
SPRINGFIELD, OREGON

PROJECT NUMBER:  
PROPOSAL NUMBER:

REVISION HISTORY

| REV# | DATE     | DESCRIPTION            |
|------|----------|------------------------|
| 10   |          |                        |
| 9    |          |                        |
| 8    |          |                        |
| 7    |          |                        |
| 6    |          |                        |
| 5    |          |                        |
| 4    |          |                        |
| 3    |          |                        |
| 2    |          |                        |
| 1    |          |                        |
| 0    | 08.27.25 | RELEASE FOR APPROVAL'S |

SHEET INFORMATION

DRAWING TYPE: SHOP DRAWINGS  
DRAWN BY: MAM  
STANDARDS REVIEW: RAC  
TECHNICAL REVIEW: RAC

THIS DOCUMENT CONTAINS PROPRIETARY INFORMATION OF 9WOOD, INC.  
COPYRIGHT © 2025 9WOOD, INC.  
ALL RIGHTS RESERVED.

KEY NOTES

- 1 15/16" HEAVY DUTY T-BAR MAINRUNNER (TYP; BY SUBCONTRACTOR)
- 2 15/16" T-BAR CROSSTEE (TYP; BY SUBCONTRACTOR)
- 3 HANGER WIRE (TYP; BY SUBCONTRACTOR)
- 4 WALL ANGLE AND APPROPRIATE INSTALLATION FASTENER (TYP; BY SUBCONTRACTOR)
- 5 PERIMETER CONDITION (TYP; BY OTHERS)

SHEET TITLE

**SYSTEM DETAILS**

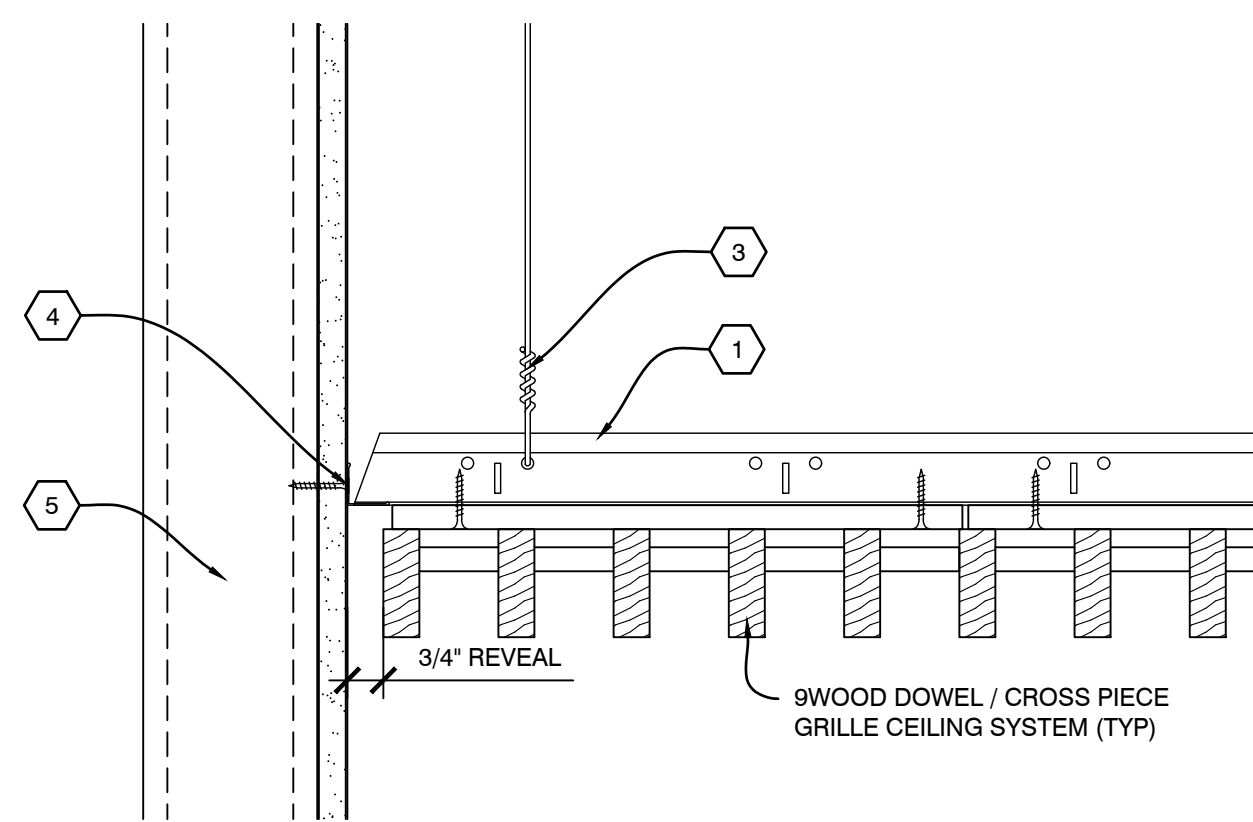

**B1** SECTION - PERIMETER  
SCALE: 1/4" = 1'

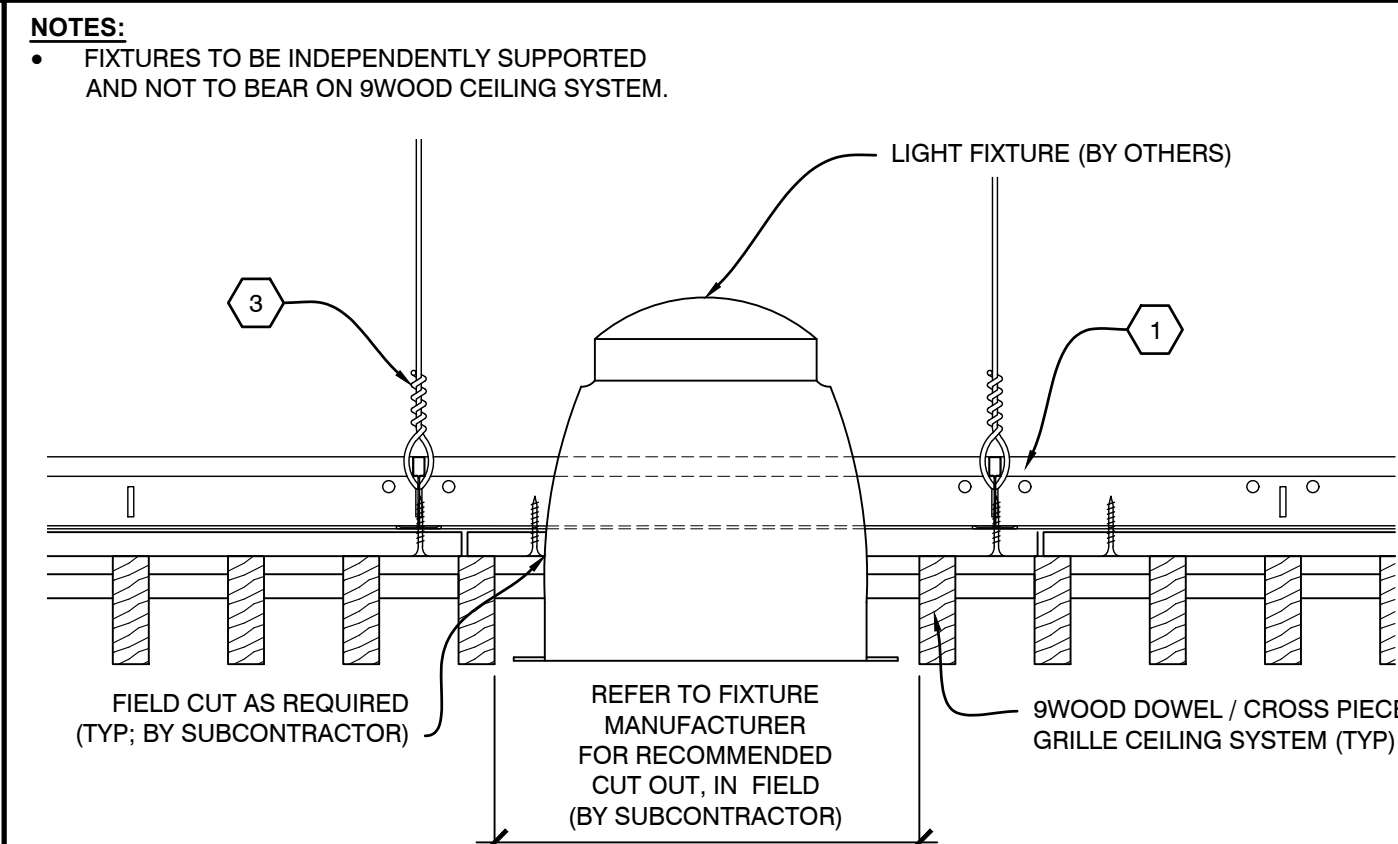

**B2** SECTION - LIGHT FIXTURE  
SCALE: 1/4" = 1'

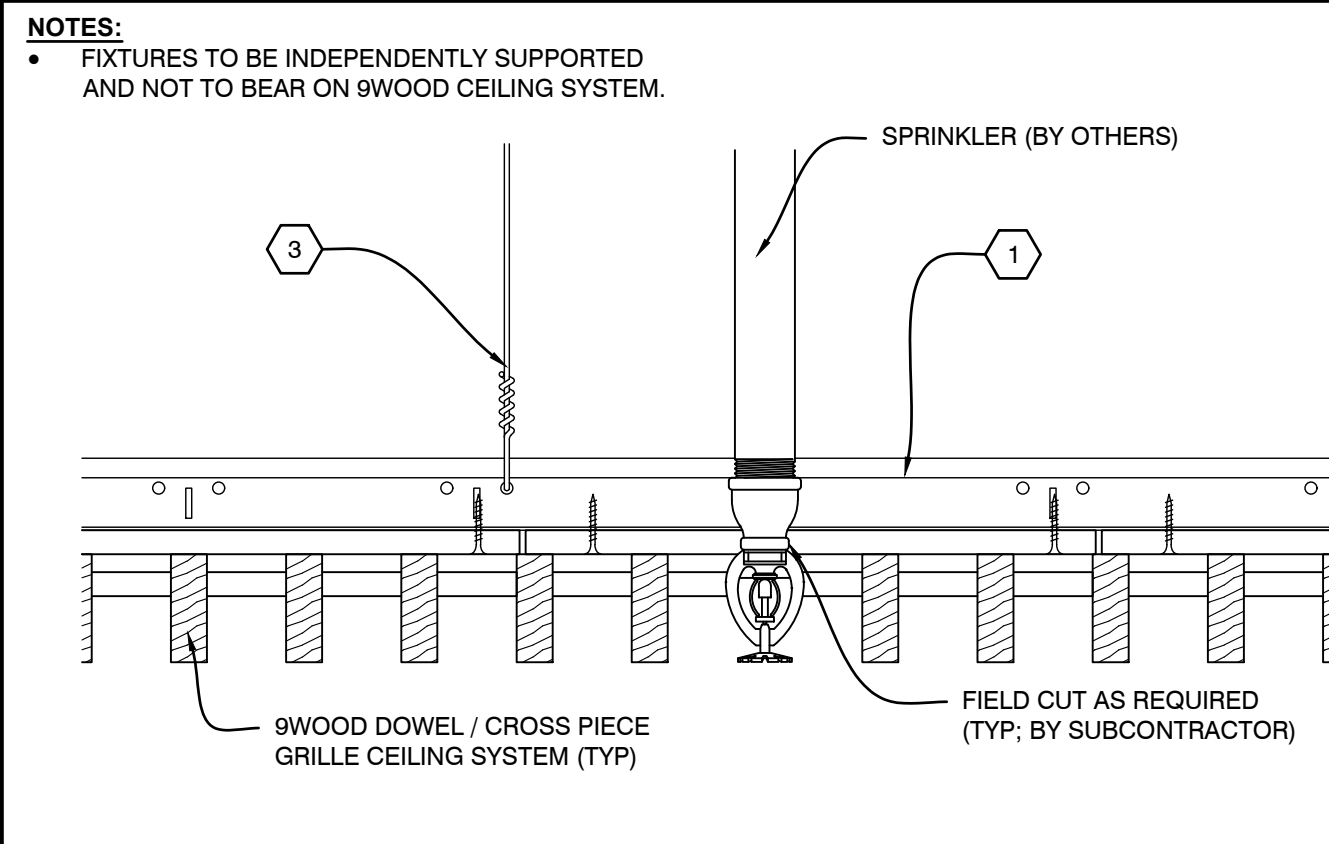

**B3** SECTION - SPRINKLER  
SCALE: 1/4" = 1'

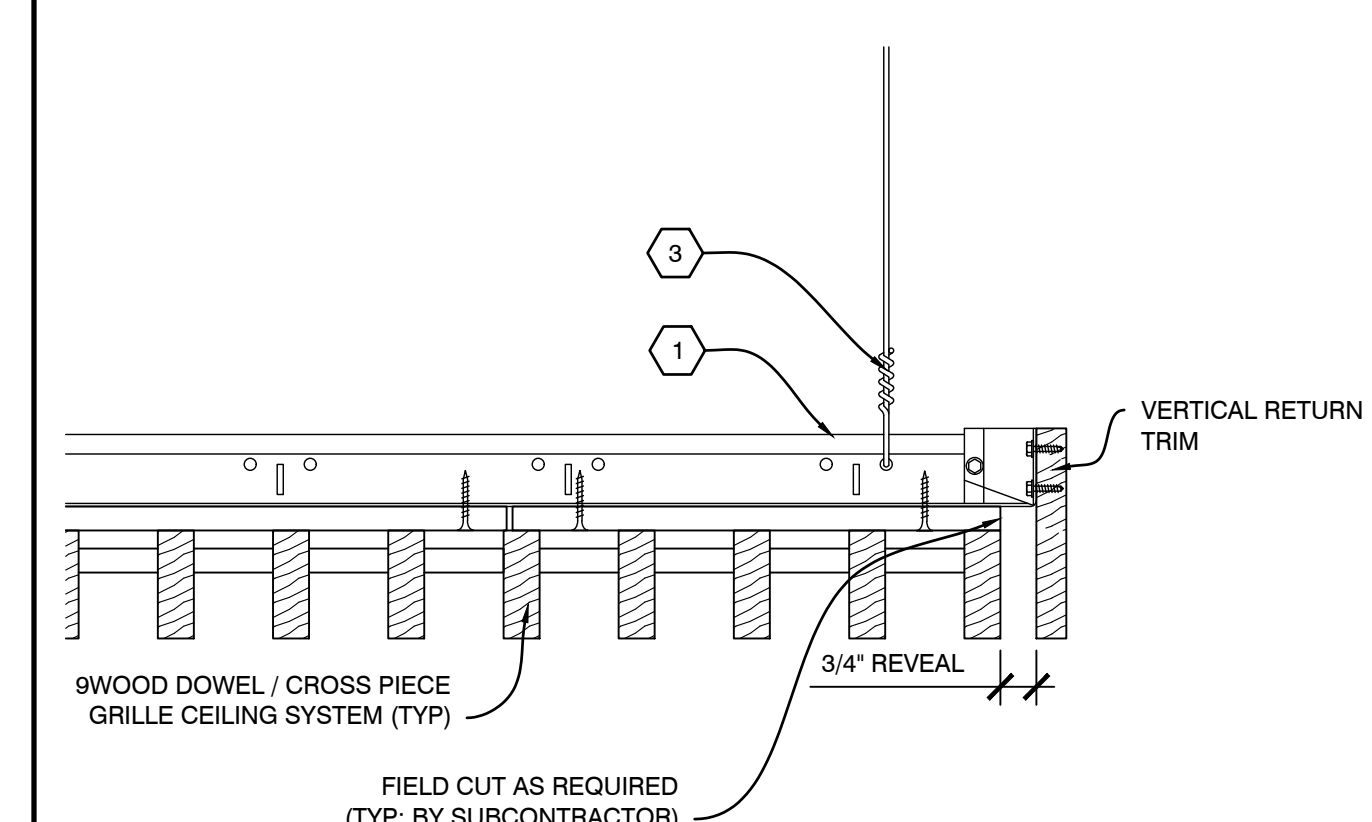

**B4** SECTION - PERIMETER  
SCALE: 1/4" = 1'

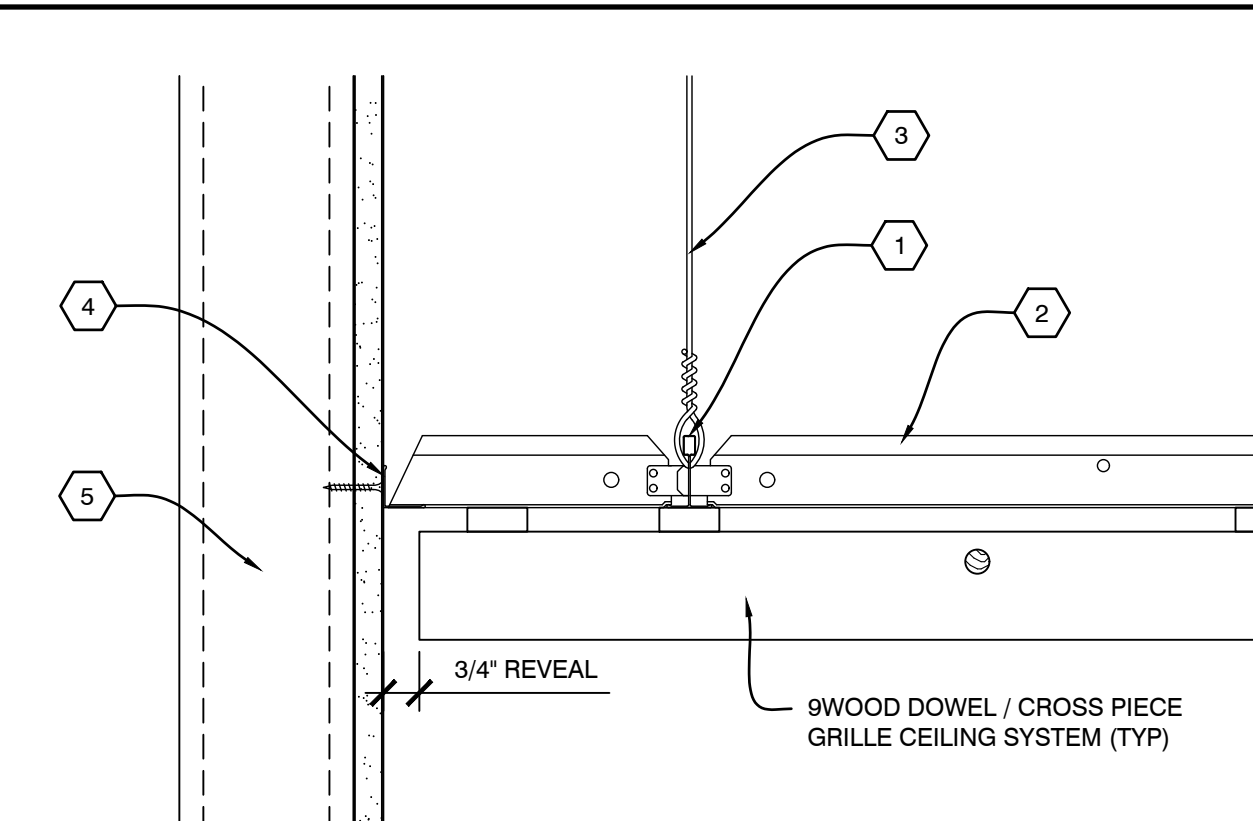

**A1** SECTION - PERIMETER  
SCALE: 1/4" = 1'

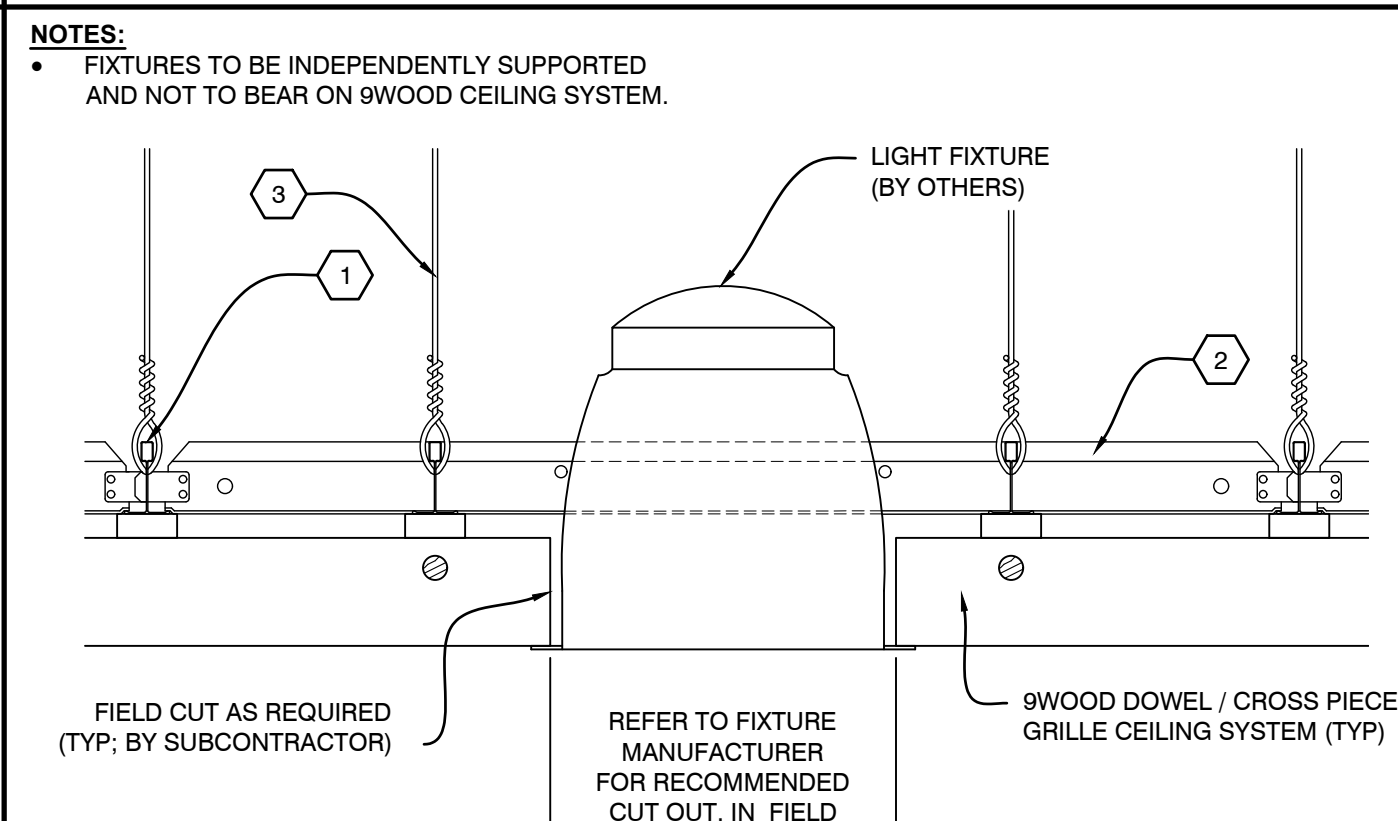

**A2** SECTION - LIGHT FIXTURE  
SCALE: 1/4" = 1'

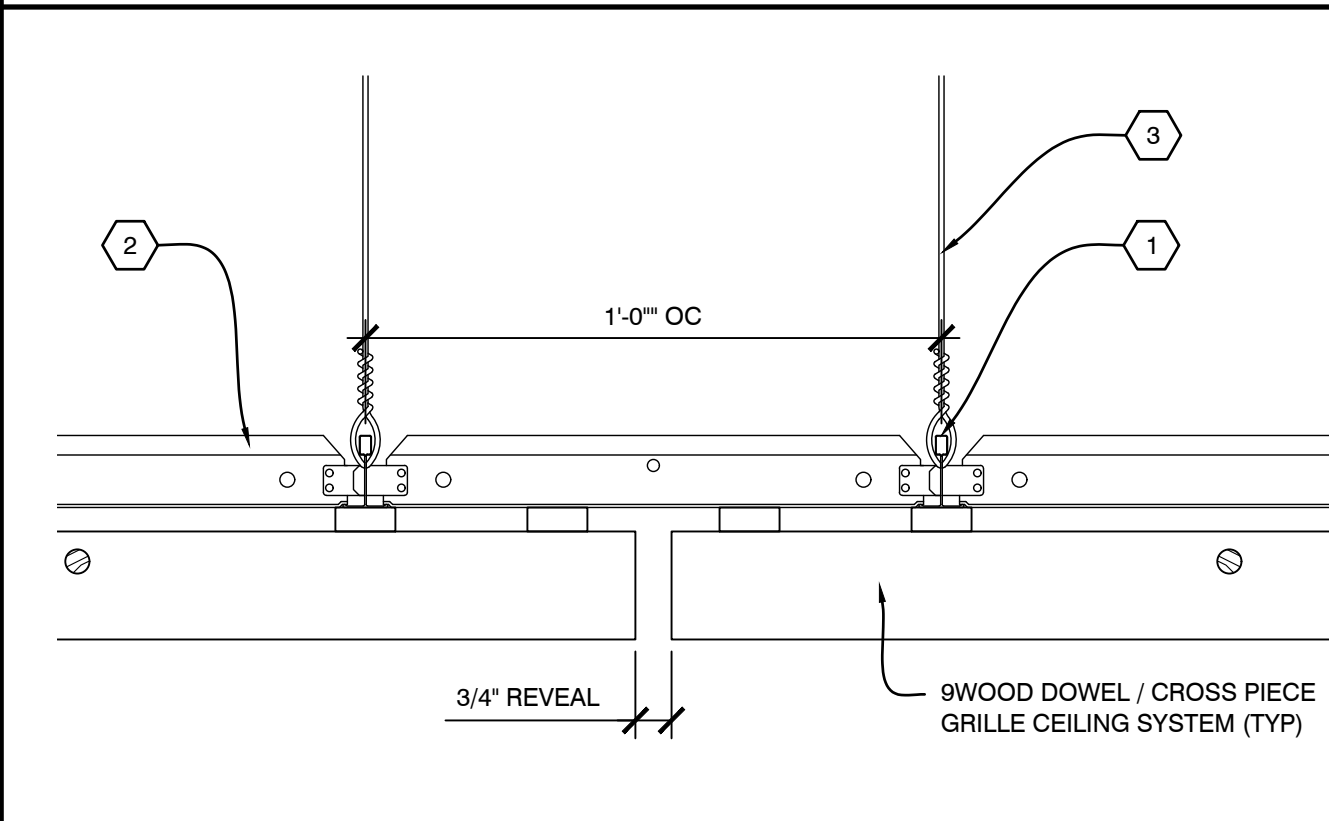

**A3** SECTION - ABUTTING REVEAL  
SCALE: 1/4" = 1'

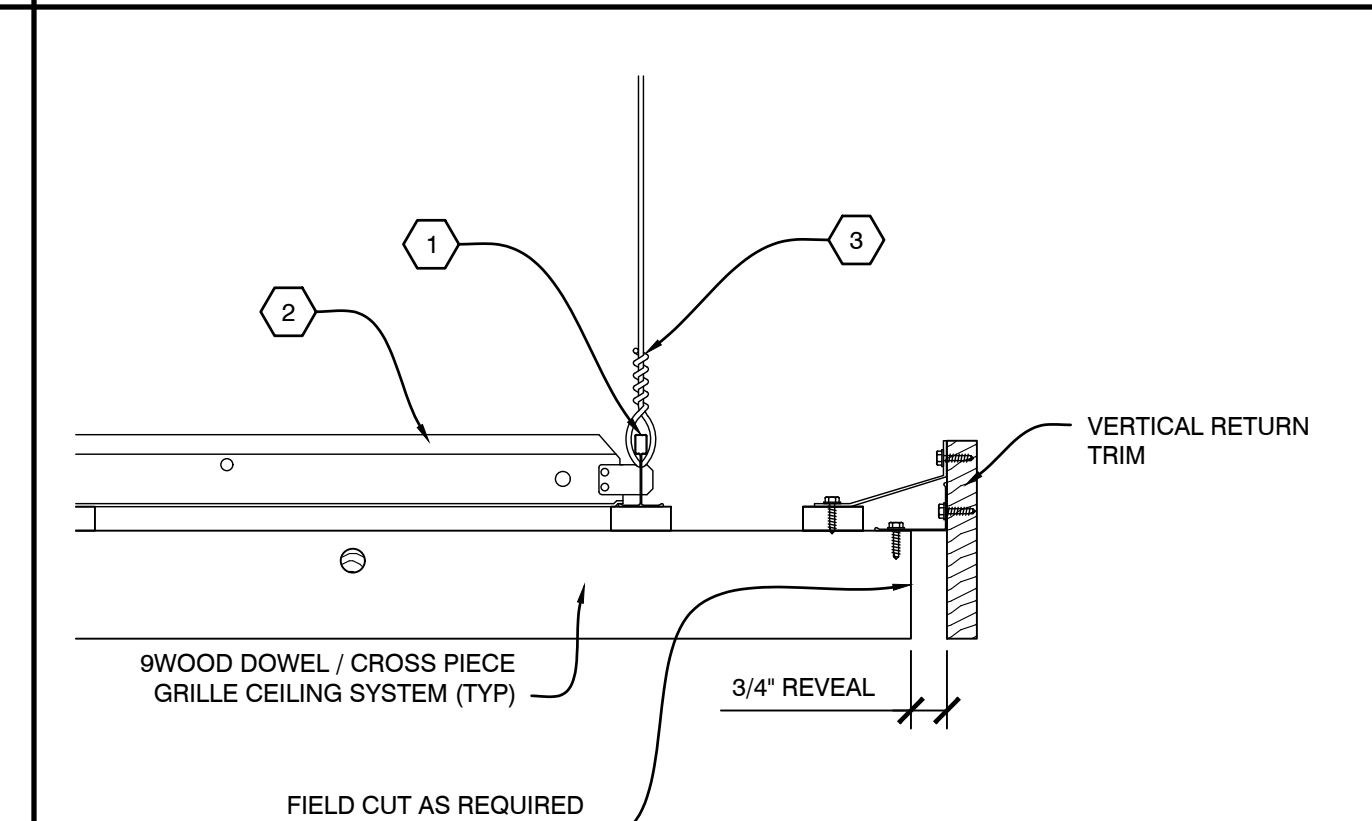

**A4** SECTION - PERIMETER  
SCALE: 1/4" = 1'

| REV# | DATE     | DESCRIPTION            |
|------|----------|------------------------|
| 10   |          |                        |
| 9    |          |                        |
| 8    |          |                        |
| 7    |          |                        |
| 6    |          |                        |
| 5    |          |                        |
| 4    |          |                        |
| 3    |          |                        |
| 2    |          |                        |
| 1    |          |                        |
| 0    | 08.27.25 | RELEASE FOR APPROVAL'S |

- 1 15/16" HEAVY DUTY T-BAR MAINRUNNER (TYP. BY SUBCONTRACTOR)
- 2 15/16" T-BAR CROSSTEE (TYP. BY SUBCONTRACTOR)
- 3 HANGER WIRE (TYP. BY SUBCONTRACTOR)
- 4 WALL ANGLE AND APPROPRIATE INSTALLATION FASTENER (TYP. BY SUBCONTRACTOR)
- 5 PERIMETER CONDITION (TYP. BY OTHERS)

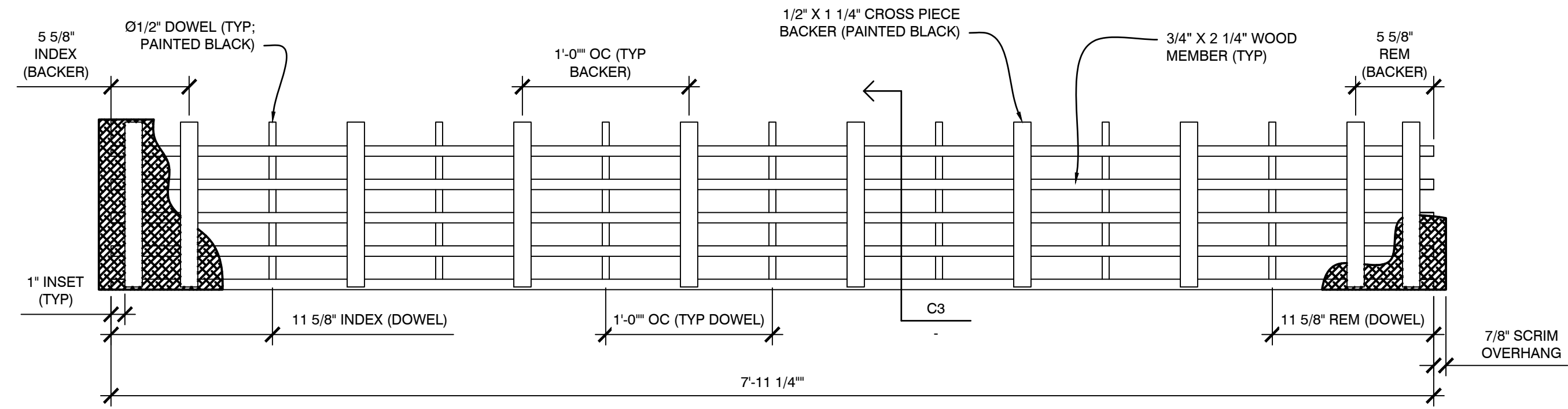

**D3** PLAN VIEW - CROSS PIECE BACKER WOOD GRILLE  
SCALE: 1 1/2" = 1"

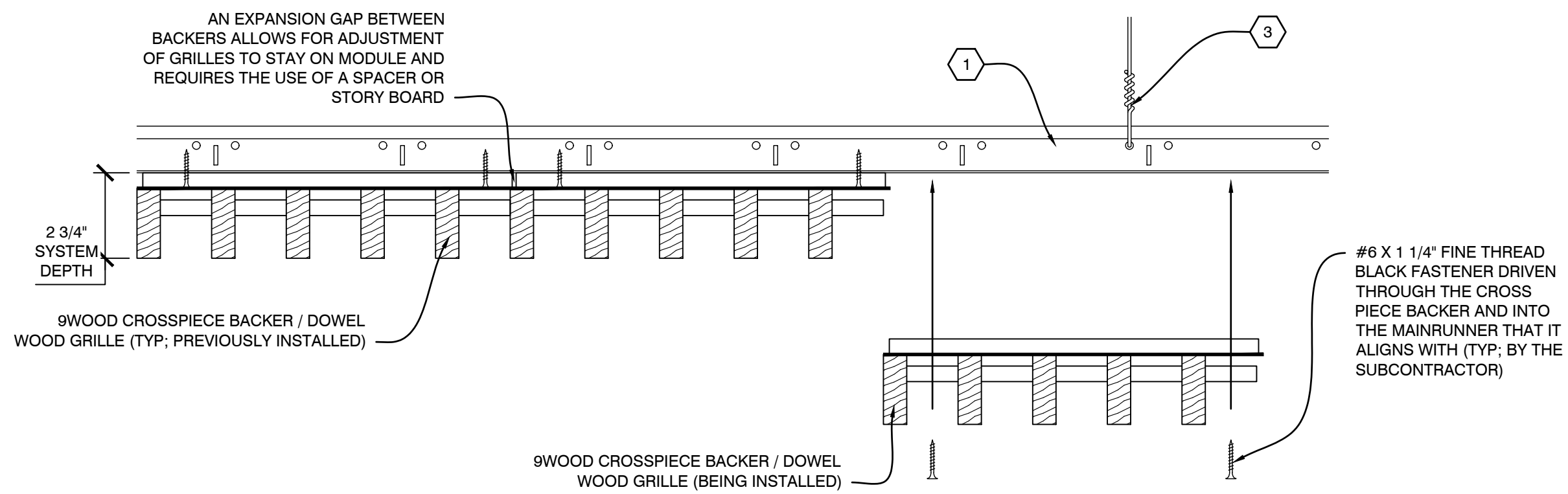

**C1** INSTALLATION PROCESS - CROSS PIECE BACKER WOOD GRILLE  
SCALE: 1/4" = 1"

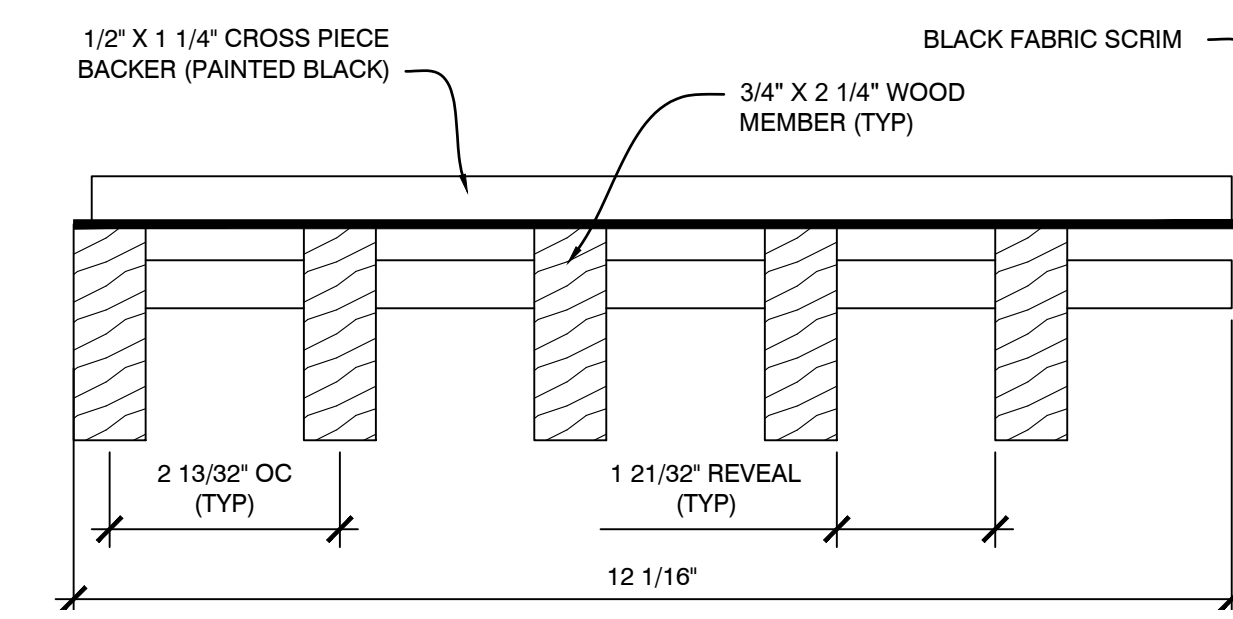

**C3** SECTION - CROSS PIECE BACKER WOOD GRILLE  
SCALE: 1/2" = 1"

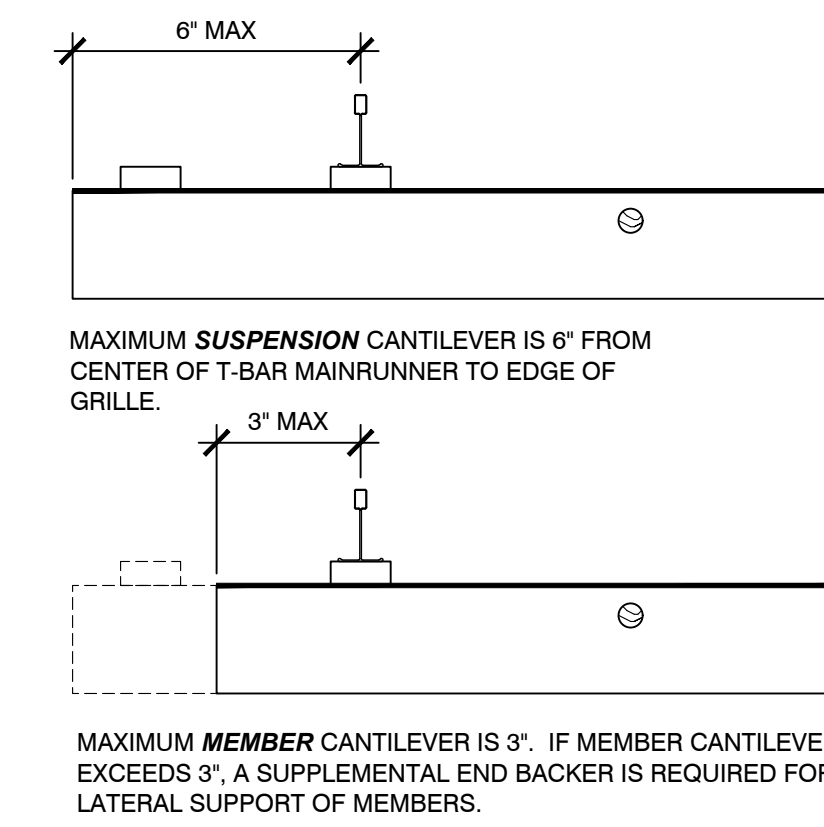

**C4** SECTION - CANTILEVER RULES  
SCALE: 1/4" = 1"

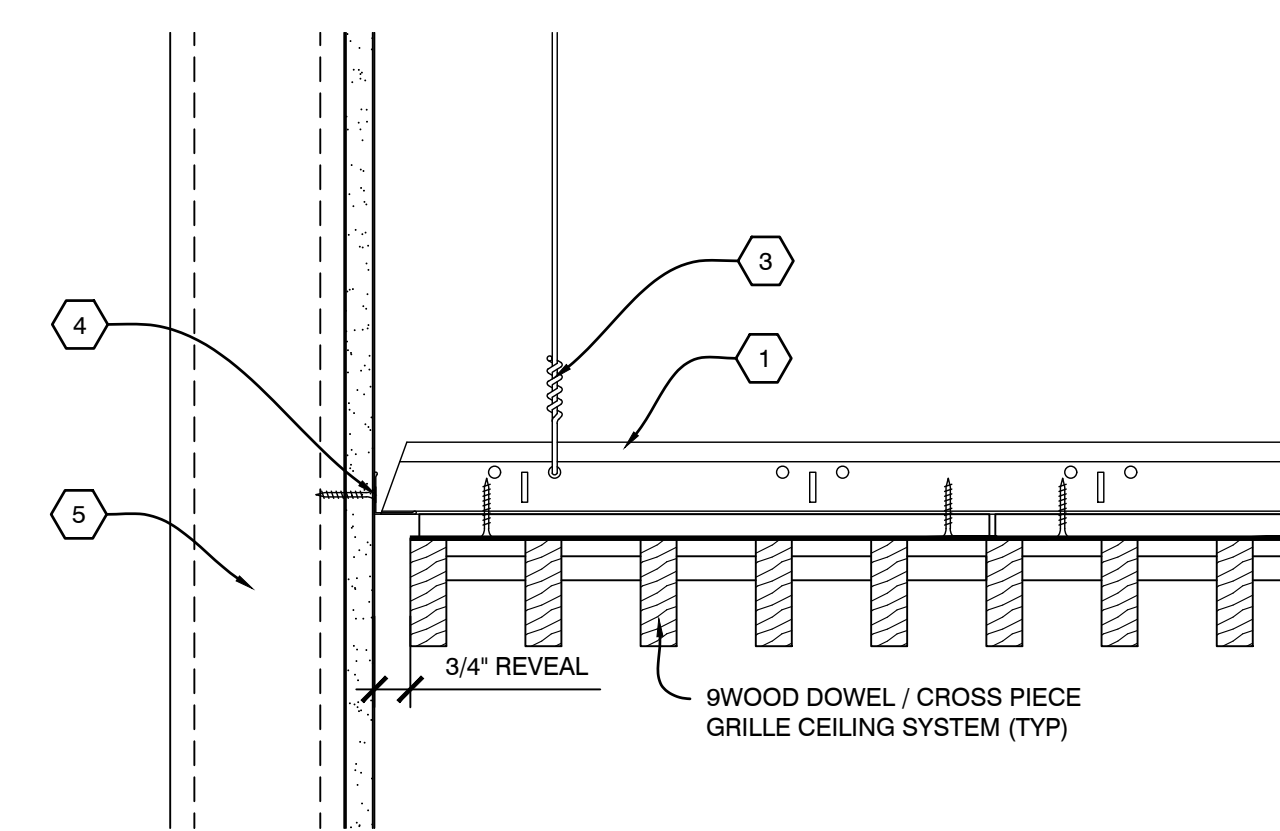

**B1** SECTION - PERIMETER  
SCALE: 1/4" = 1"

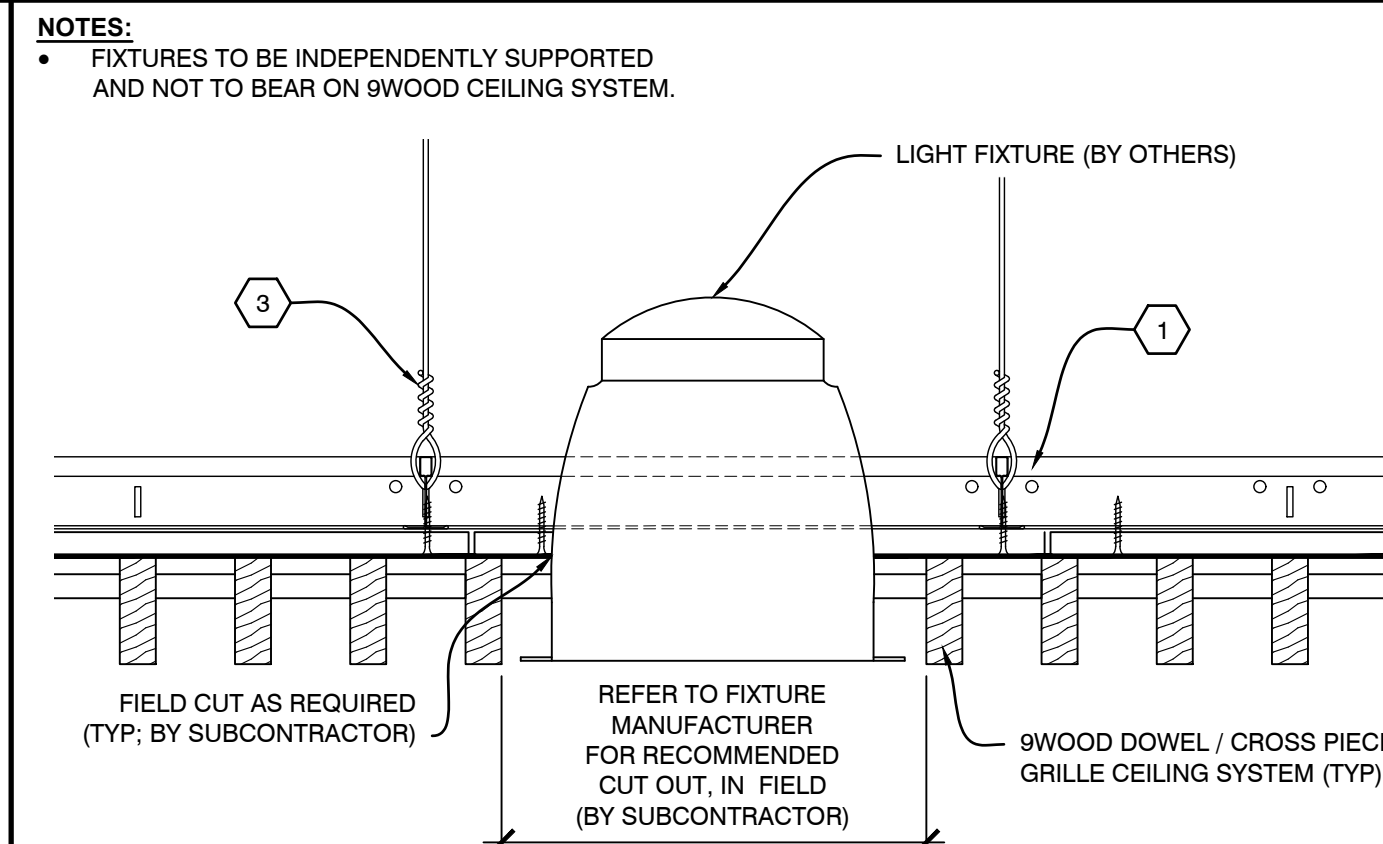

**B2** SECTION - LIGHT FIXTURE  
SCALE: 1/4" = 1"

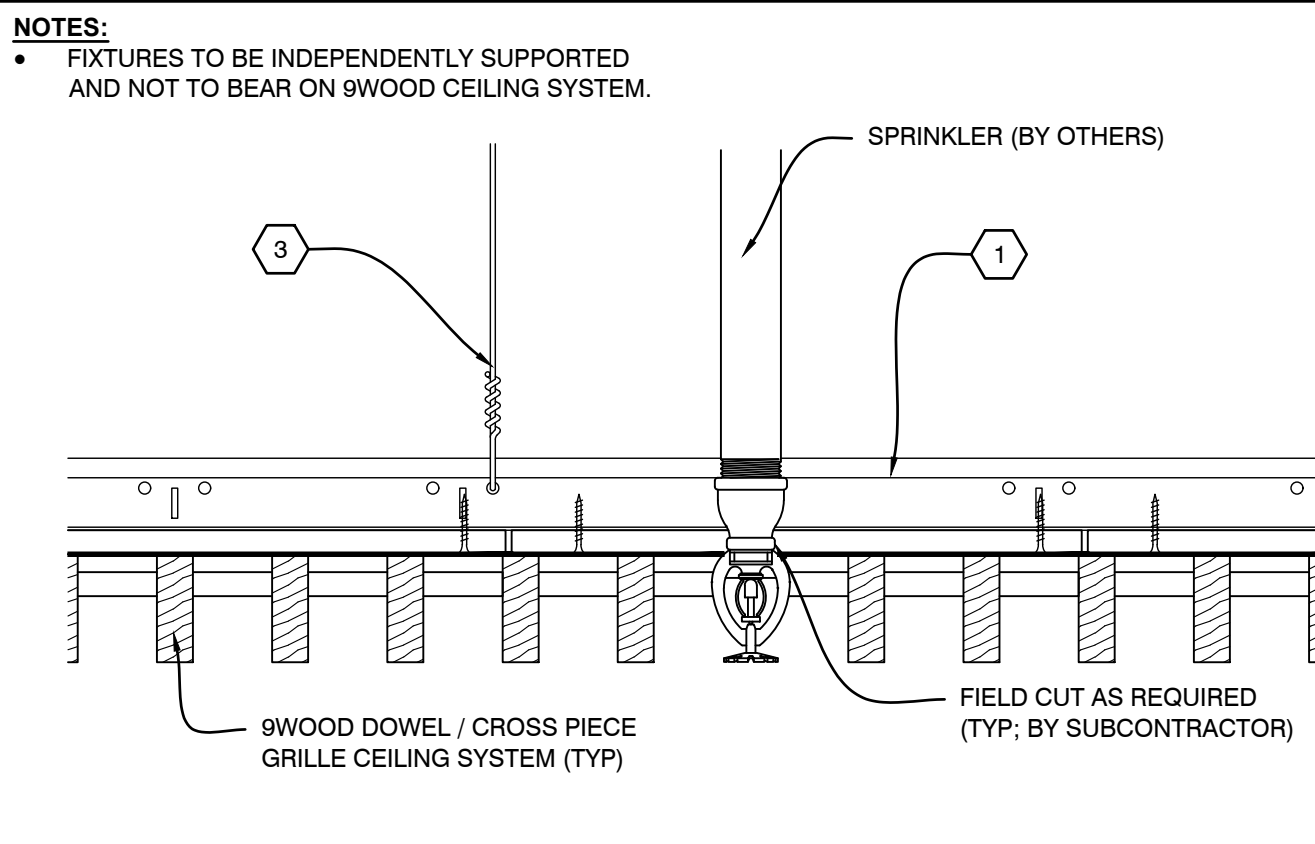

**B3** SECTION - SPRINKLER  
SCALE: 1/4" = 1"

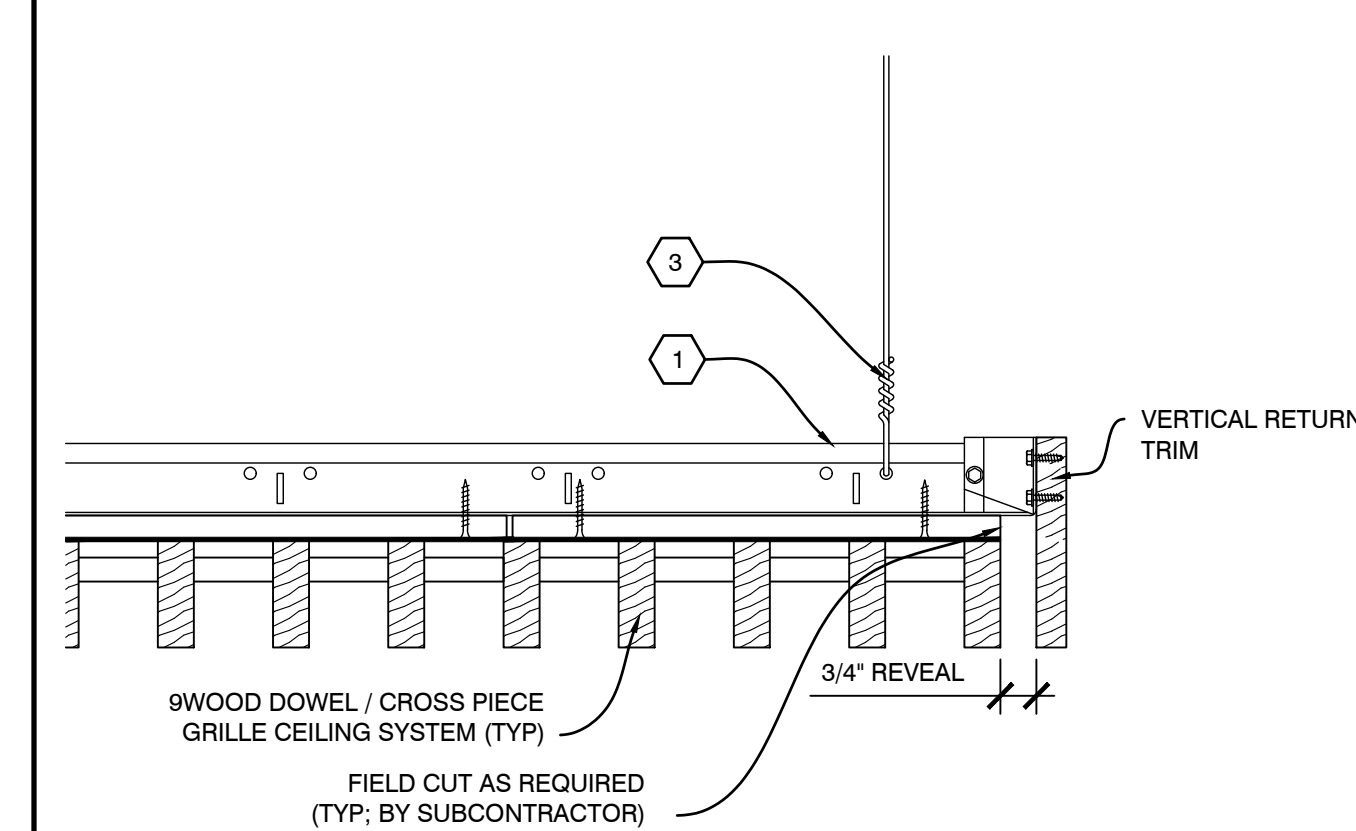

**B4** SECTION - PERIMETER  
SCALE: 1/4" = 1"

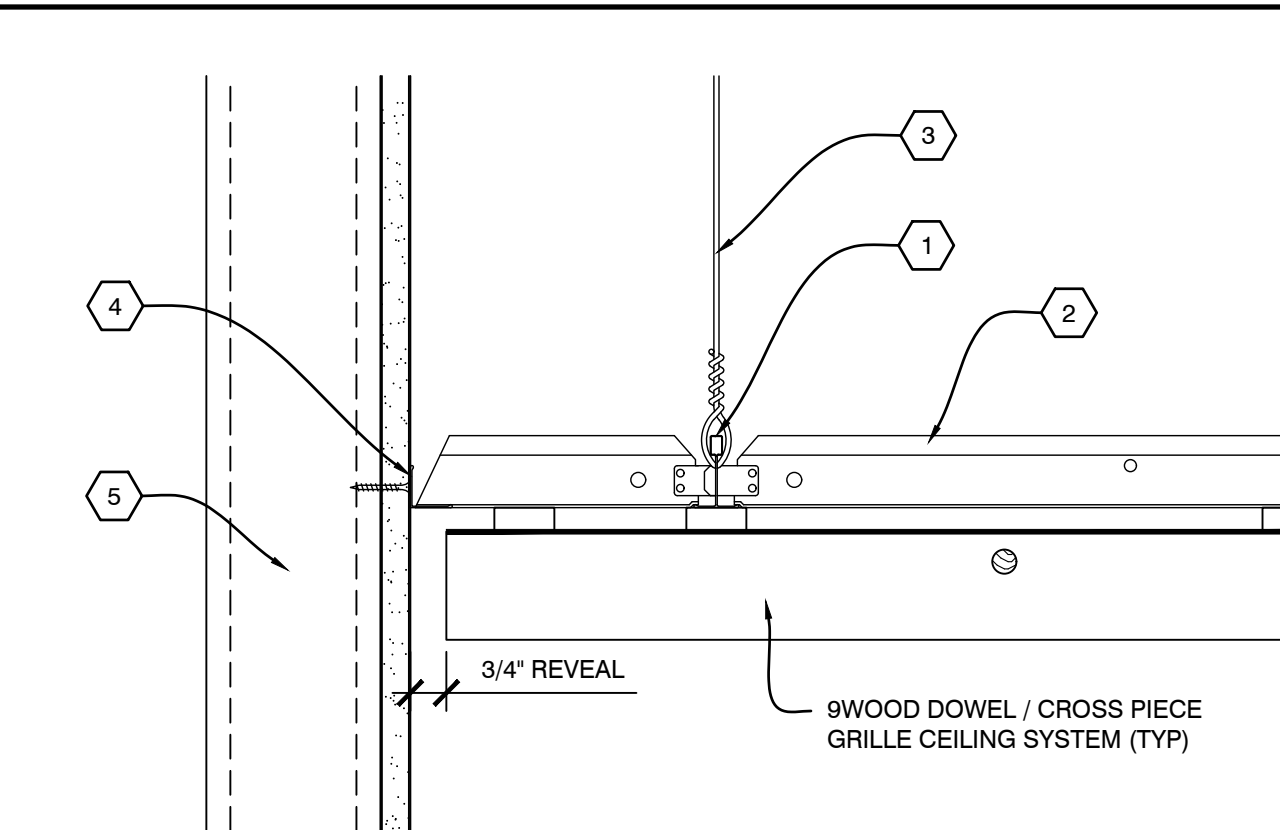

**A1** SECTION - PERIMETER  
SCALE: 1/4" = 1"

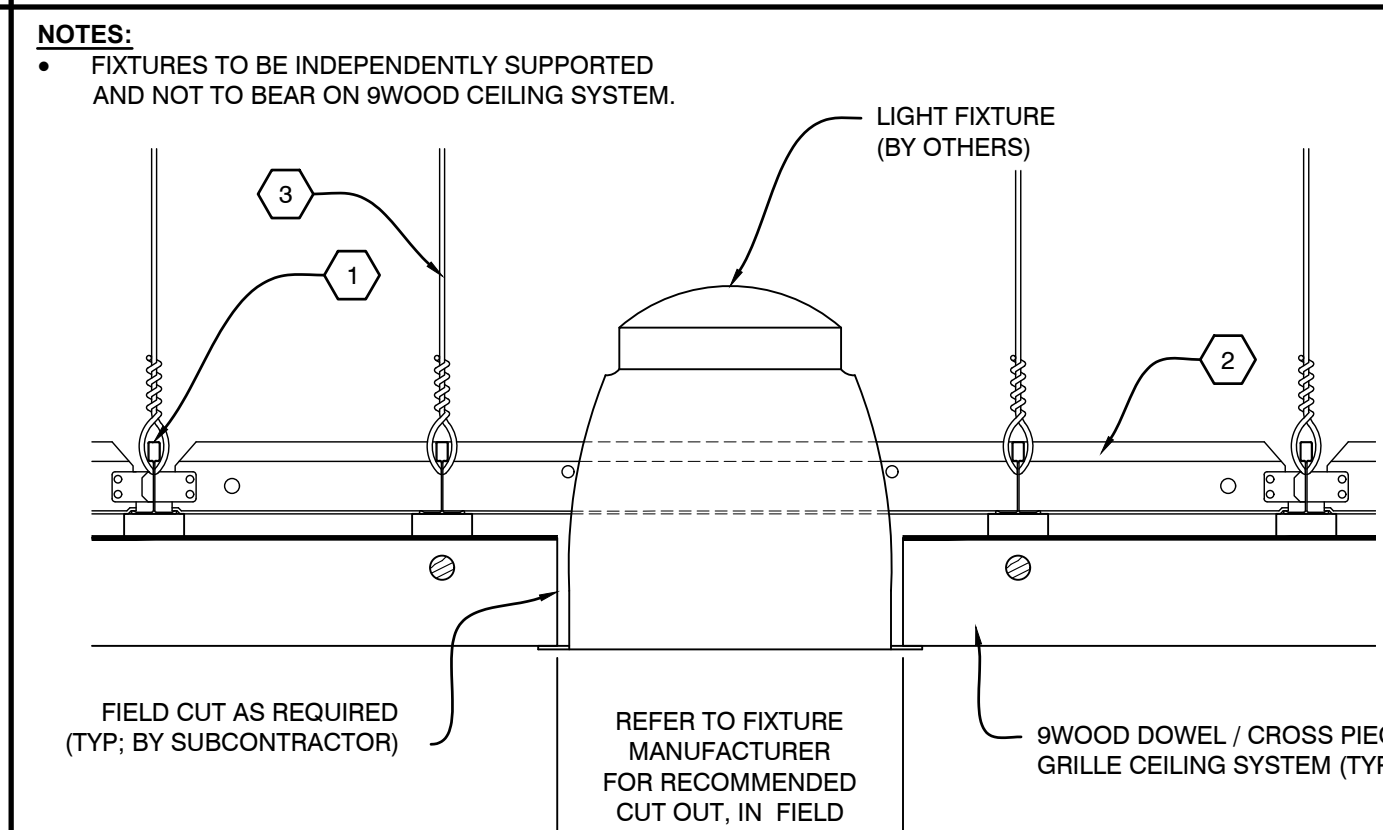

**A2** SECTION - LIGHT FIXTURE  
SCALE: 1/4" = 1"

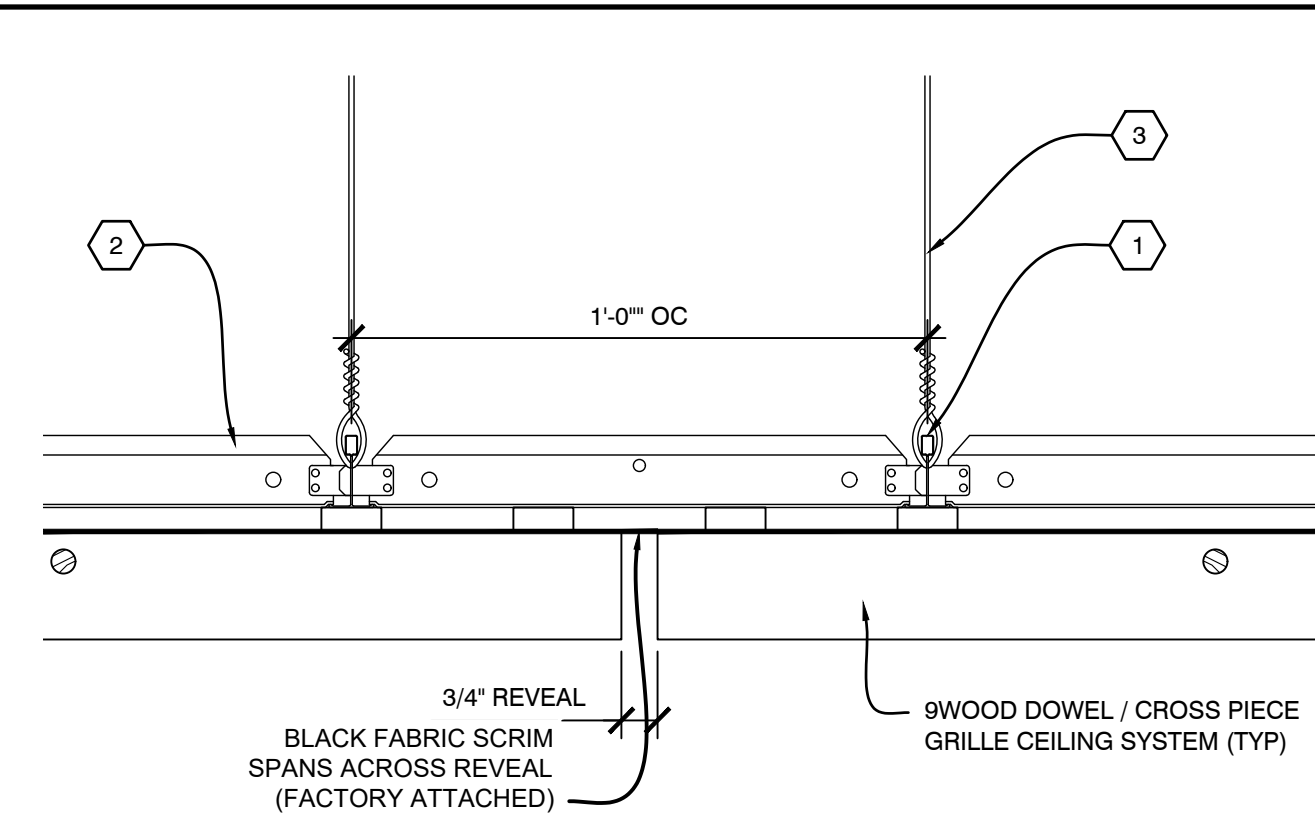

**A3** SECTION - ABUTTING REVEAL  
SCALE: 1/4" = 1"

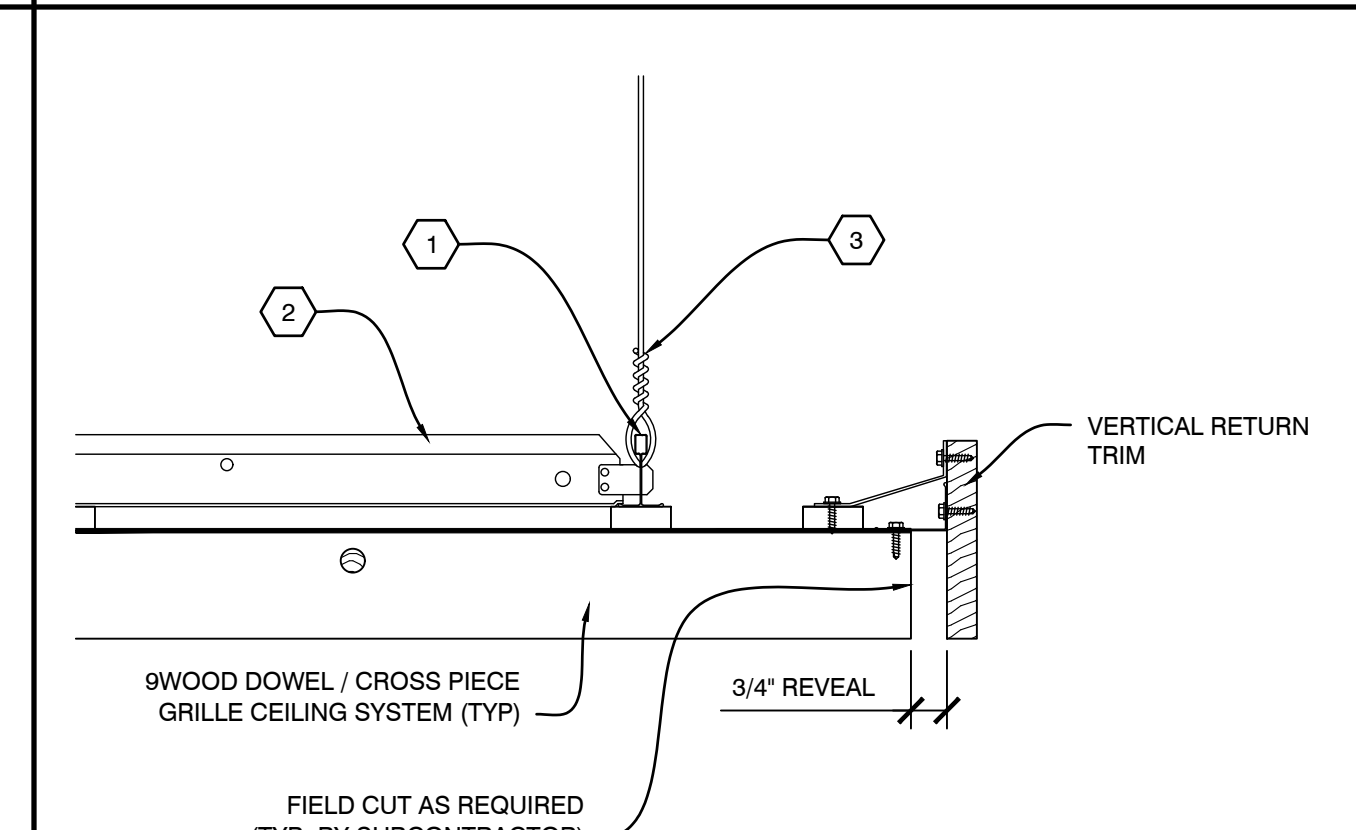

**A4** SECTION - PERIMETER  
SCALE: 1/4" = 1"