

**D3** PLAN VIEW - CROSS PIECE BACKER WOOD GRILLE  
SCALE: 1 1/2" = 1"

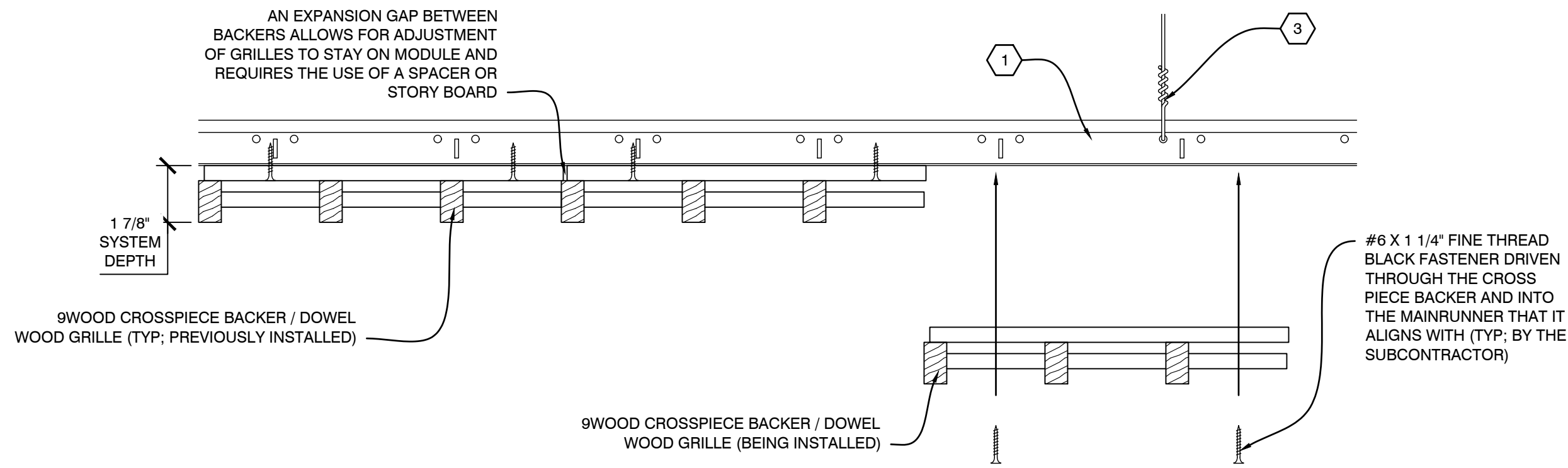

**C1** INSTALLATION PROCESS - CROSS PIECE BACKER WOOD GRILLE  
SCALE: 1/4" = 1"

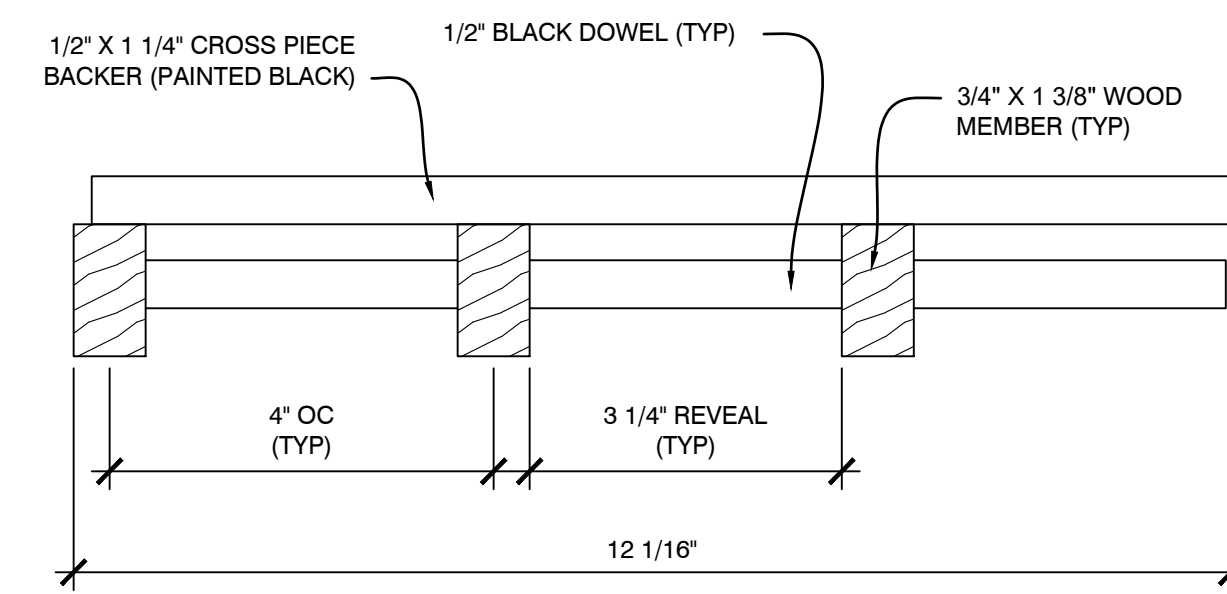

**C3** SECTION - CROSS PIECE BACKER WOOD GRILLE  
SCALE: 1/2" = 1"

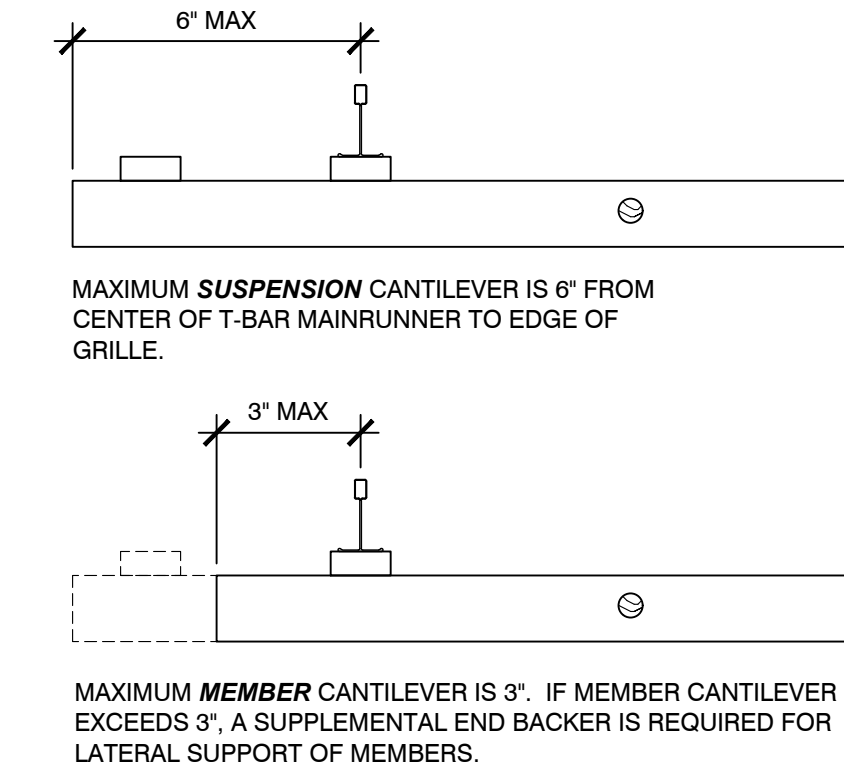

**C4** SECTION - CANTILEVER RULES  
SCALE: 1/4" = 1"

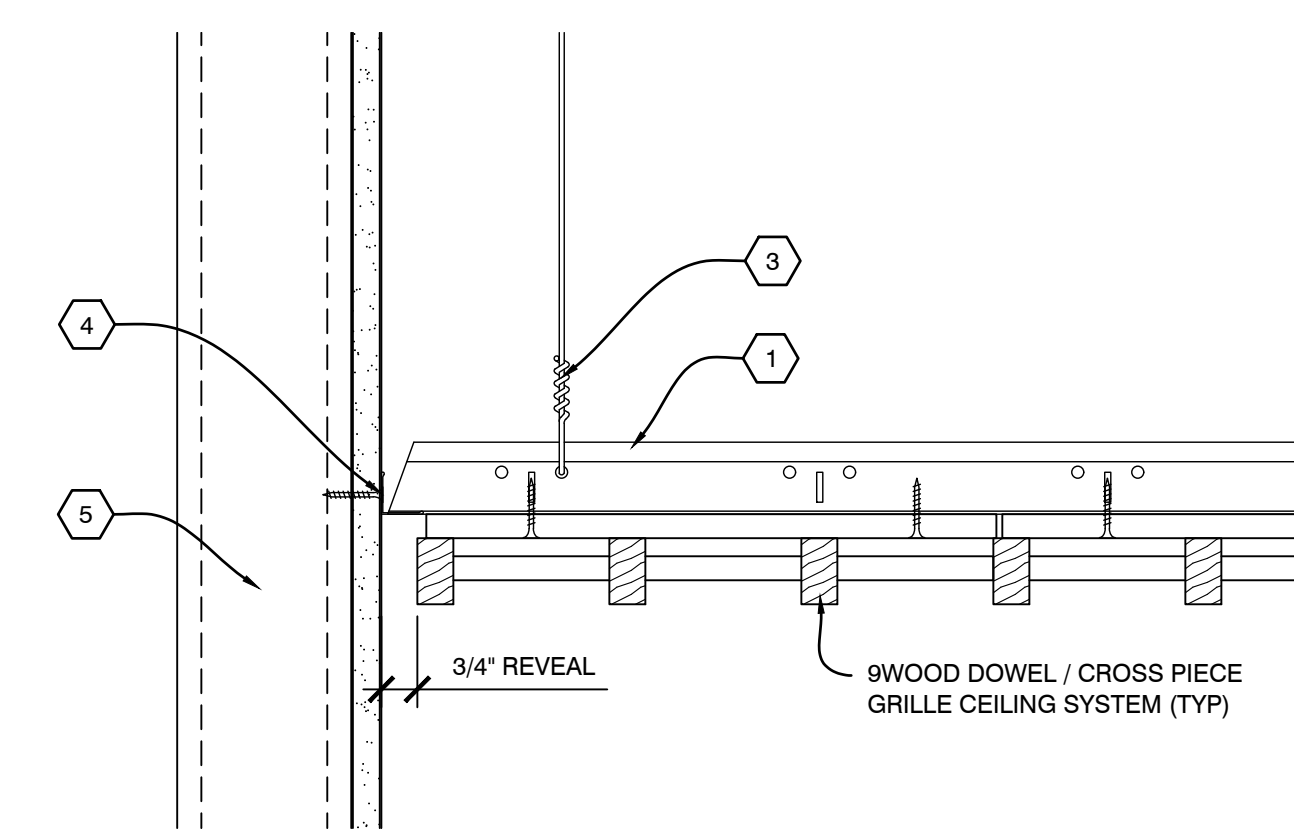

**B1** SECTION - PERIMETER  
SCALE: 1/4" = 1"

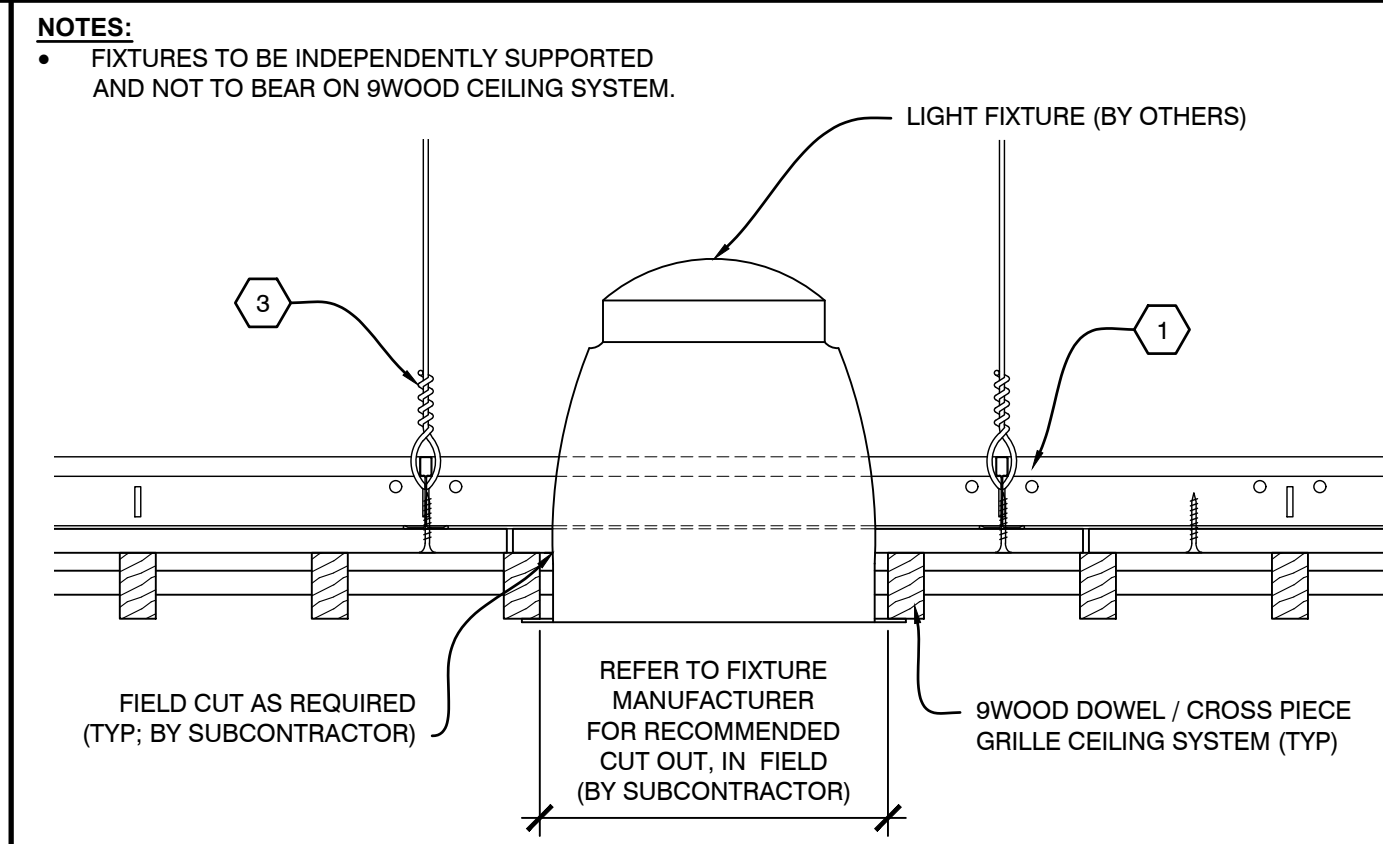

**B2** SECTION - LIGHT FIXTURE  
SCALE: 1/4" = 1"

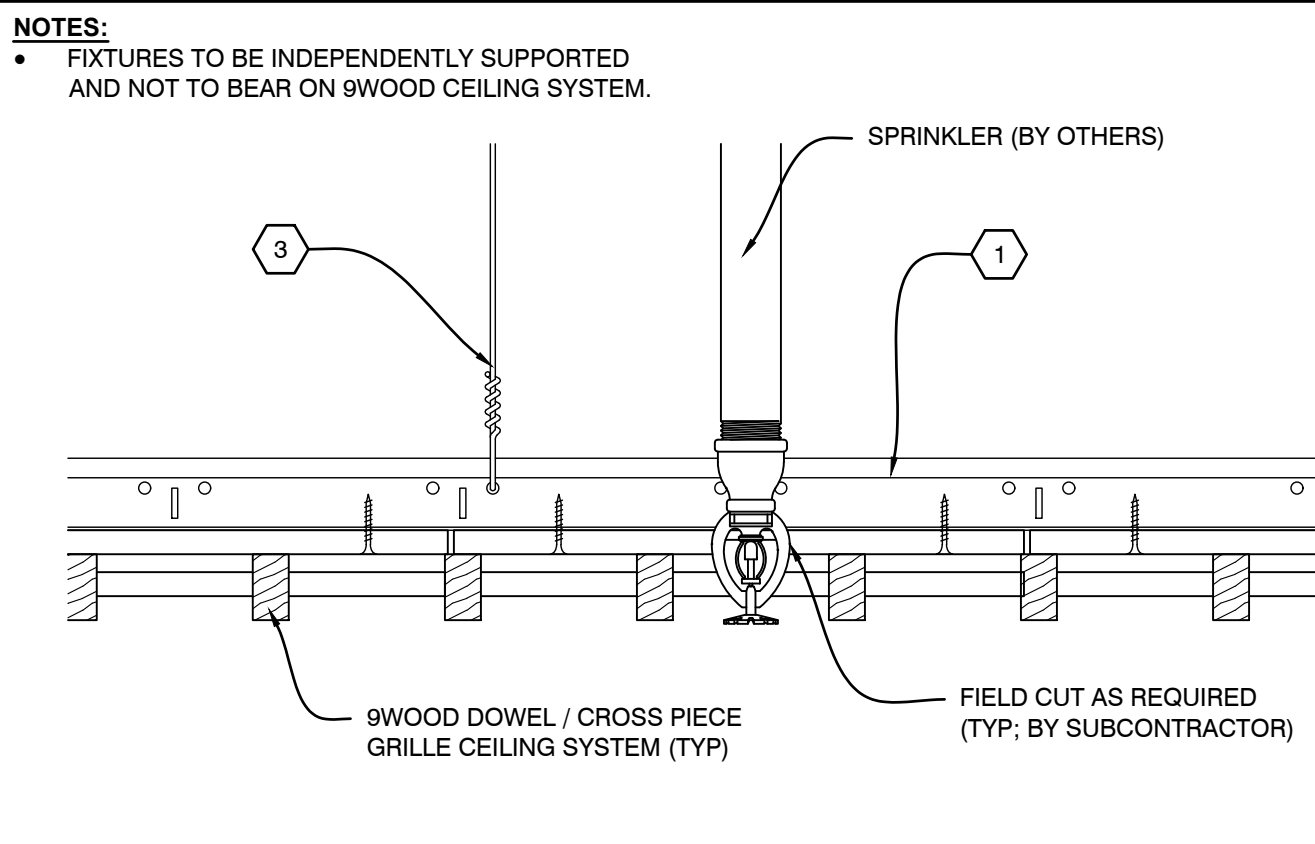

**B3** SECTION - SPRINKLER  
SCALE: 1/4" = 1"

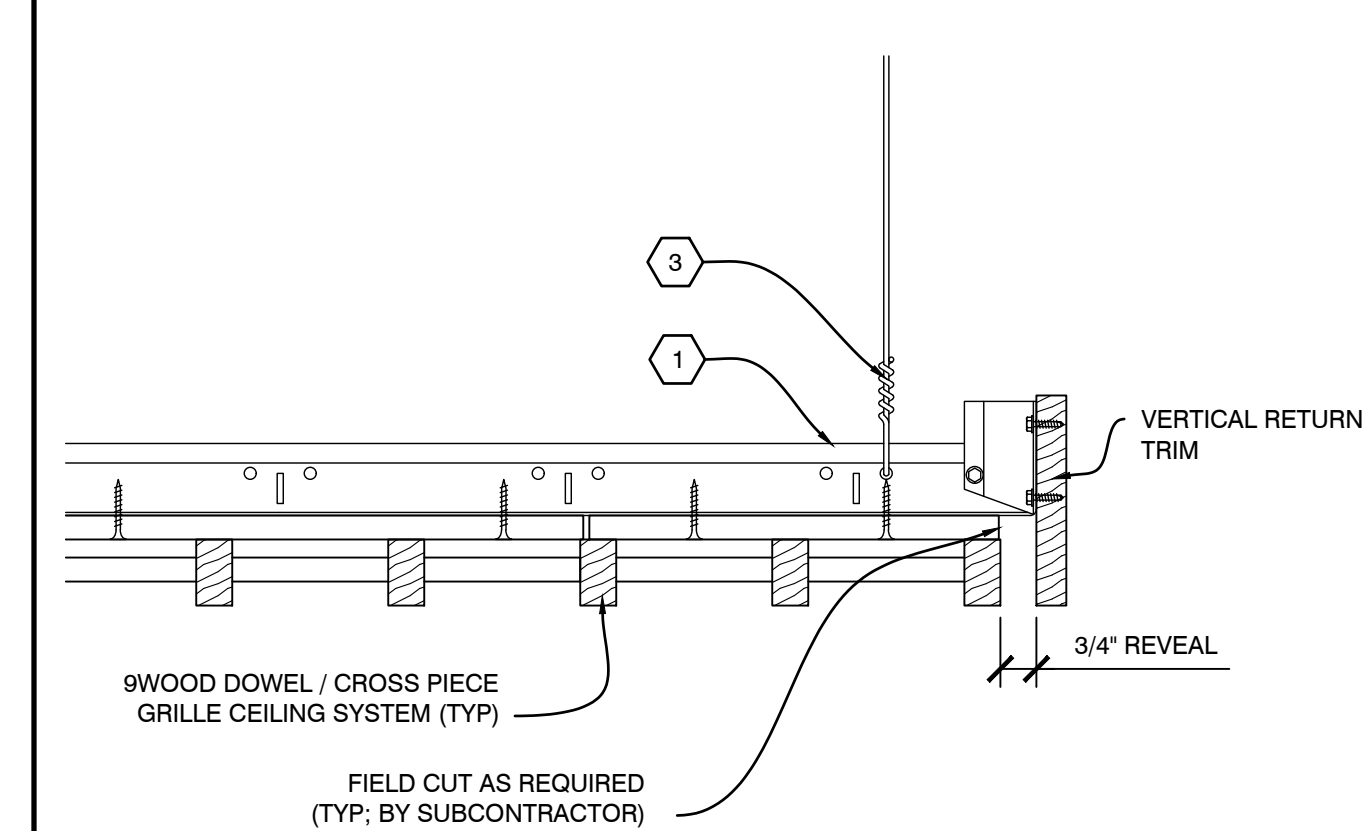

**B4** SECTION - PERIMETER  
SCALE: 1/4" = 1"

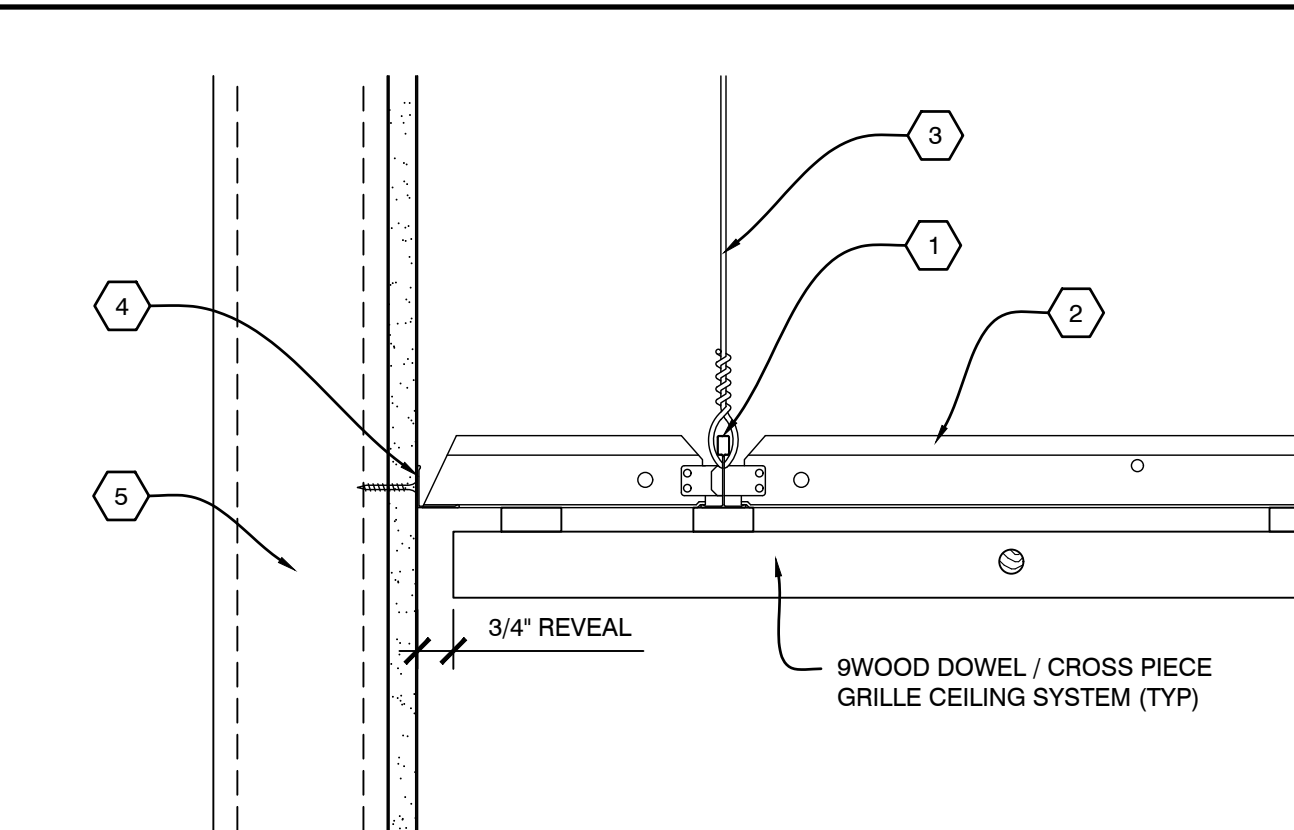

**A1** SECTION - PERIMETER  
SCALE: 1/4" = 1"

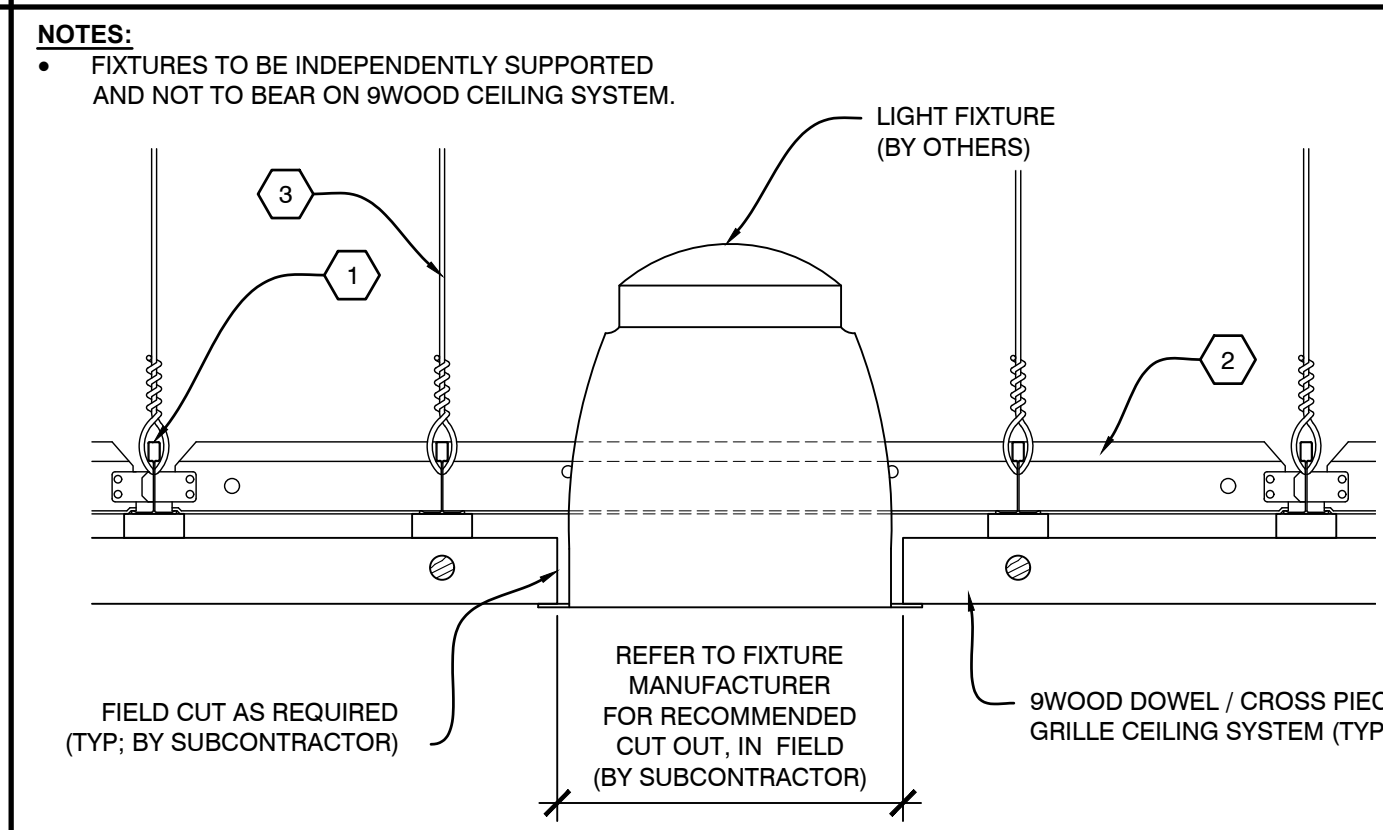

**A2** SECTION - LIGHT FIXTURE  
SCALE: 1/4" = 1"

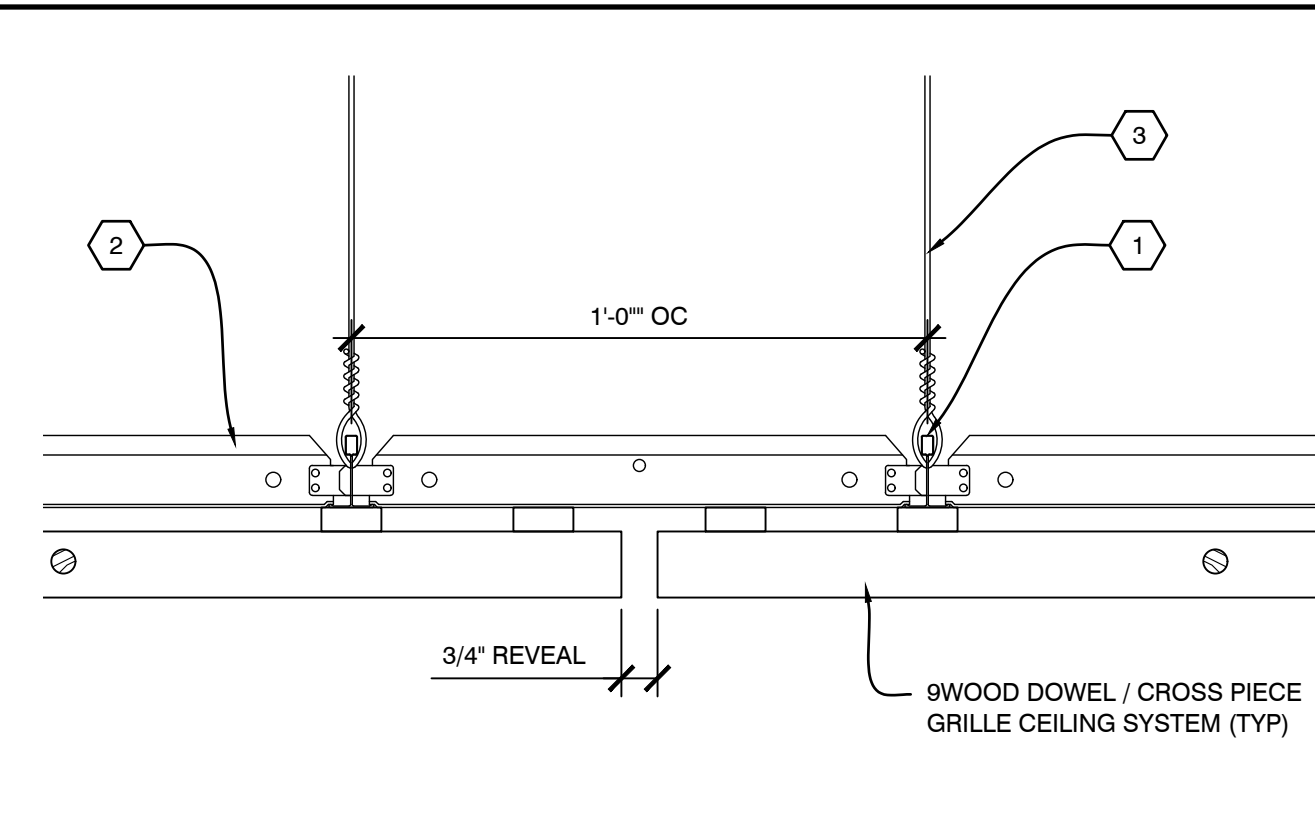

**A3** SECTION - ABUTTING REVEAL  
SCALE: 1/4" = 1"

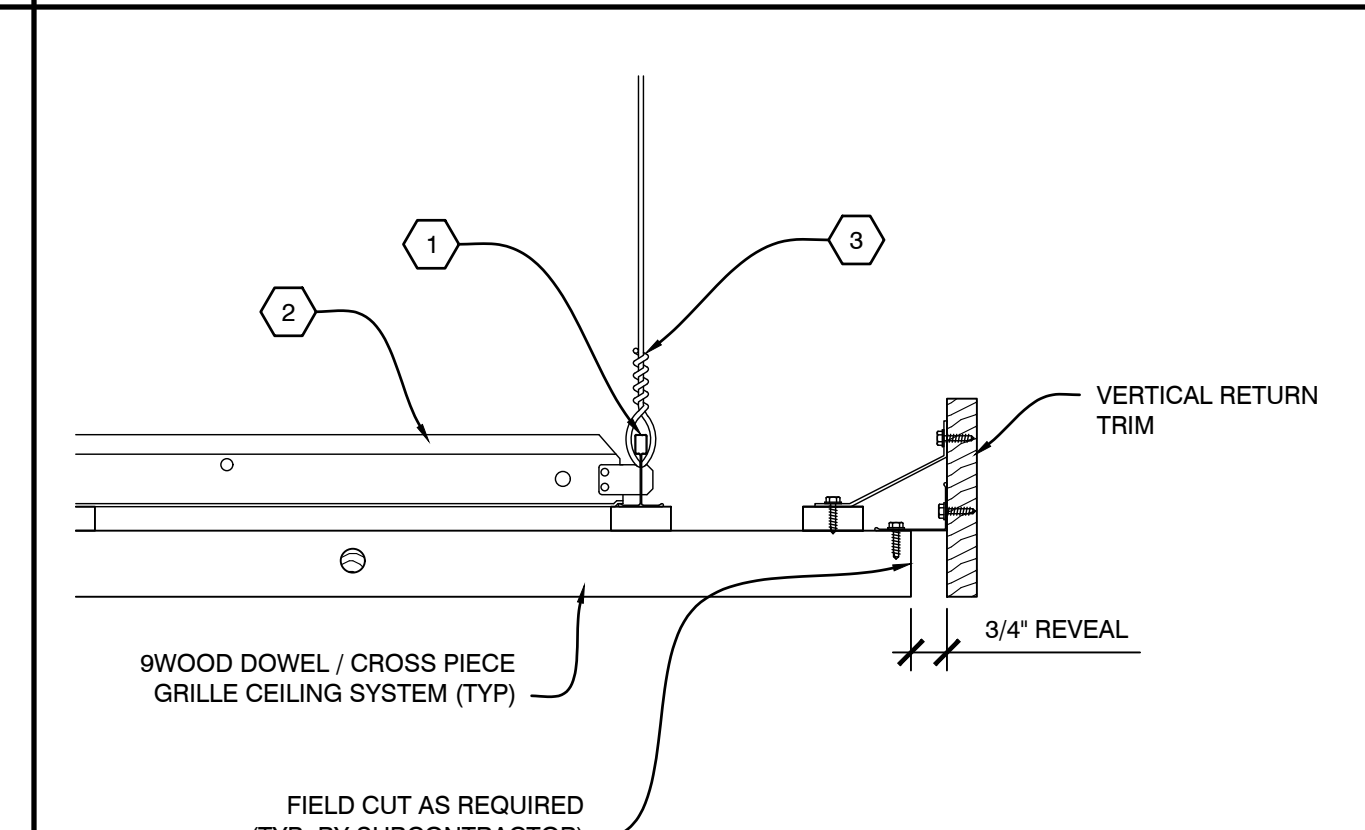

**A4** SECTION - PERIMETER  
SCALE: 1/4" = 1"

PROJECT  
**9WOOD**  
SPRINGFIELD, OREGON

PROJECT NUMBER:  
PROPOSAL NUMBER:

REVISION HISTORY

REV#	DATE	DESCRIPTION
10		
9		
8		
7		
6		
5		
4		
3		
2		
1		
0	08.27.25	RELEASE FOR APPROVAL'S

SHEET INFORMATION

DRAWING TYPE: SHOP DRAWINGS  
DRAWN BY: MAM  
STANDARDS REVIEW: RAC  
TECHNICAL REVIEW: RAC

THIS DOCUMENT CONTAINS PROPRIETARY INFORMATION OF 9WOOD, INC. COPYRIGHT © 2025 9WOOD, INC. ALL RIGHTS RESERVED.

KEY NOTES

- 1 15/16" HEAVY DUTY T-BAR MAINRUNNER (TYP. BY SUBCONTRACTOR)
- 2 15/16" T-BAR CROSSTEE (TYP. BY SUBCONTRACTOR)
- 3 HANGER WIRE (TYP. BY SUBCONTRACTOR)
- 4 WALL ANGLE AND APPROPRIATE INSTALLATION FASTENER (TYP. BY SUBCONTRACTOR)
- 5 PERIMETER CONDITION (TYP. BY OTHERS)

SHEET TITLE

**SYSTEM DETAILS**