

PROJECT

PROJECT NUMBER:
PROPOSAL NUMBER:

REVISION HISTORY

REV#	DATE	DESCRIPTION
10		
9		
8		
7		
6		
5		
4		
3		
2		
1		
0	10.03.25	RELEASE FOR APPROVALS

SHEET INFORMATION

DRAWING TYPE: SHOP DRAWINGS
DRAWN BY: BLH
STANDARDS REVIEW: RAC
TECHNICAL REVIEW: RAC

THIS DOCUMENT CONTAINS PROPRIETARY INFORMATION OF 9WOOD, INC.
COPYRIGHT © 2025 9WOOD, INC.
ALL RIGHTS RESERVED.

KEY NOTES

- 1 15/16" HEAVY DUTY T-BAR MAIN RUNNER (TYP. BY SUBCONTRACTOR)
- 2 15/16" T-BAR CROSS TEE (TYP. BY SUBCONTRACTOR)
- 3 HANGER WIRE (TYP. BY SUBCONTRACTOR)
- 4 WALL ANGLE AND APPROPRIATE INSTALLATION FASTENER (TYP. BY SUBCONTRACTOR)
- 5 PERIMETER CONDITION (TYP. BY OTHERS)
- 6 9WOOD ALIGNMENT BRACKET (TYP. FACTORY INSTALLED)
- 7 9WOOD TRUE ACCESS CLIP ASSEMBLY (TYP. FACTORY INSTALLED)

SHEET TITLE

SYSTEM DETAILS

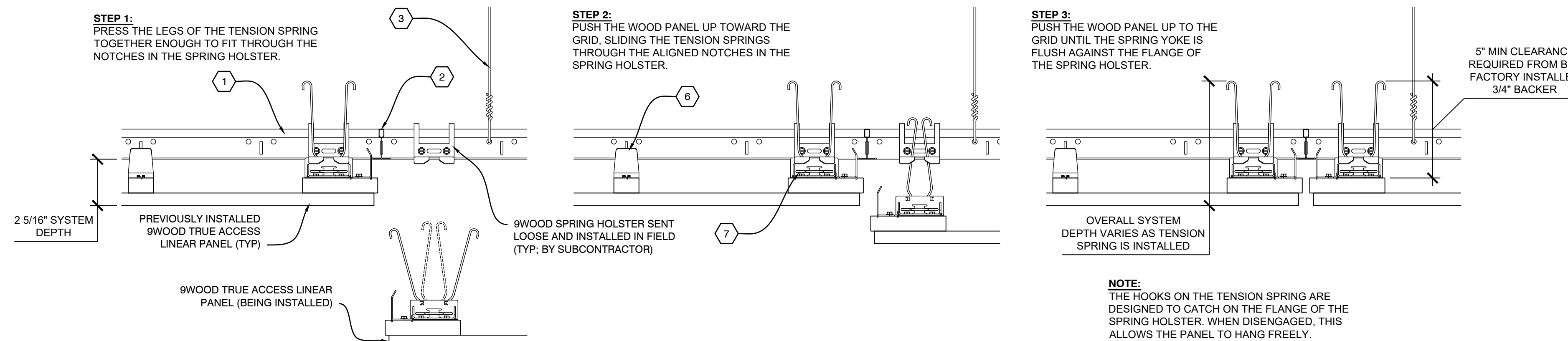

D2 INSTALLATION PROCESS - TRUE ACCESS LINEAR CEILING PANEL

SCALE: 1/4" = 1"

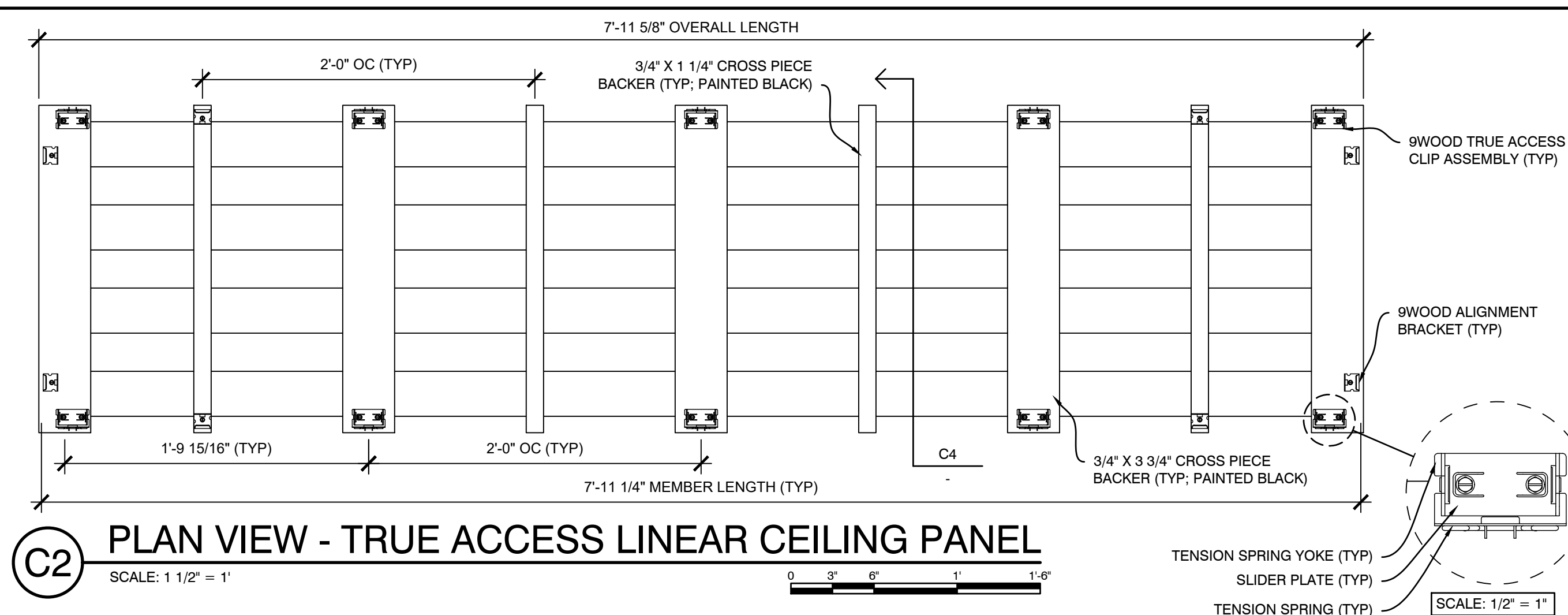

C2 PLAN VIEW - TRUE ACCESS LINEAR CEILING PANEL

SCALE: 1/2" = 1"

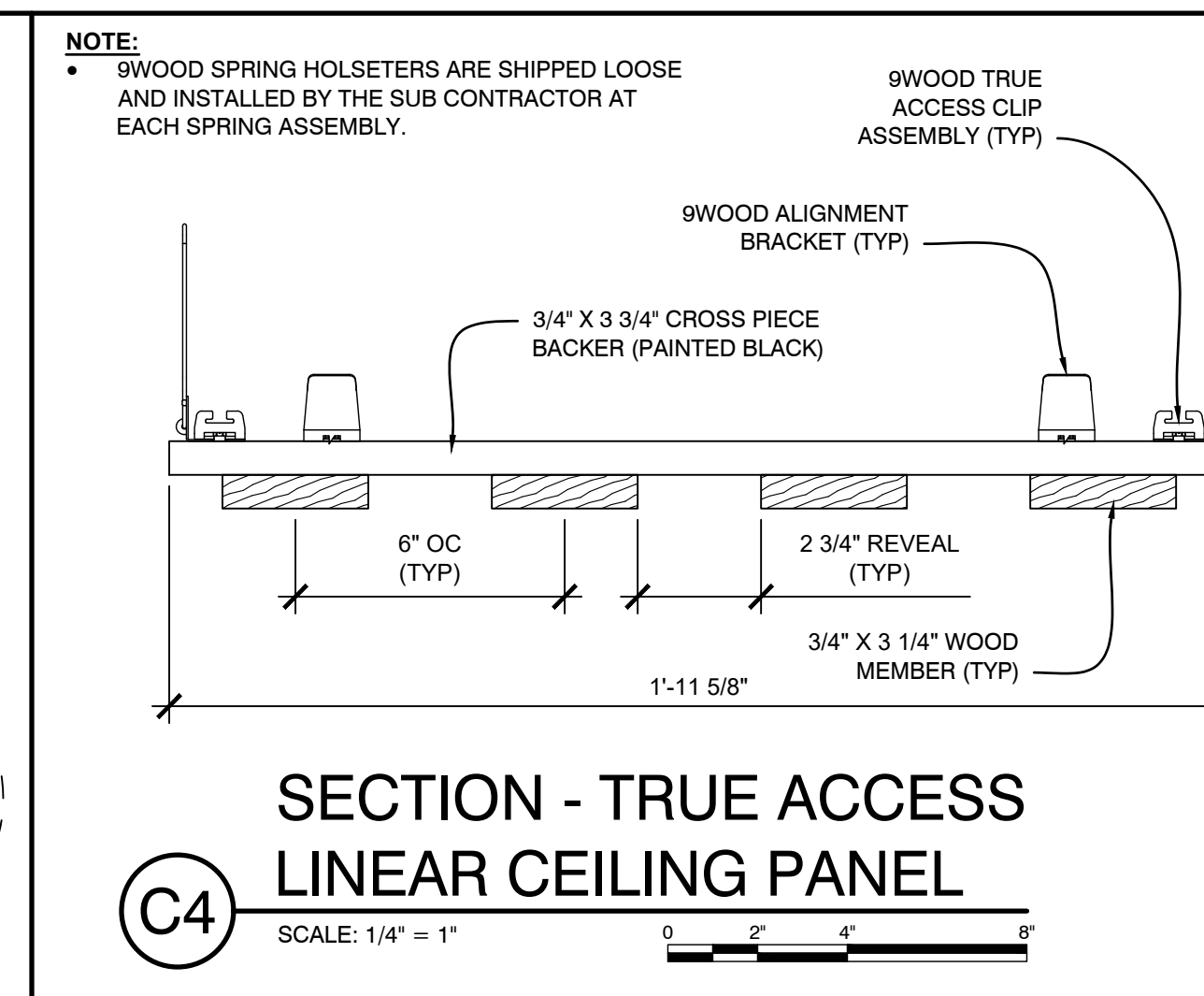

C4 SECTION - TRUE ACCESS LINEAR CEILING PANEL

SCALE: 1/4" = 1"

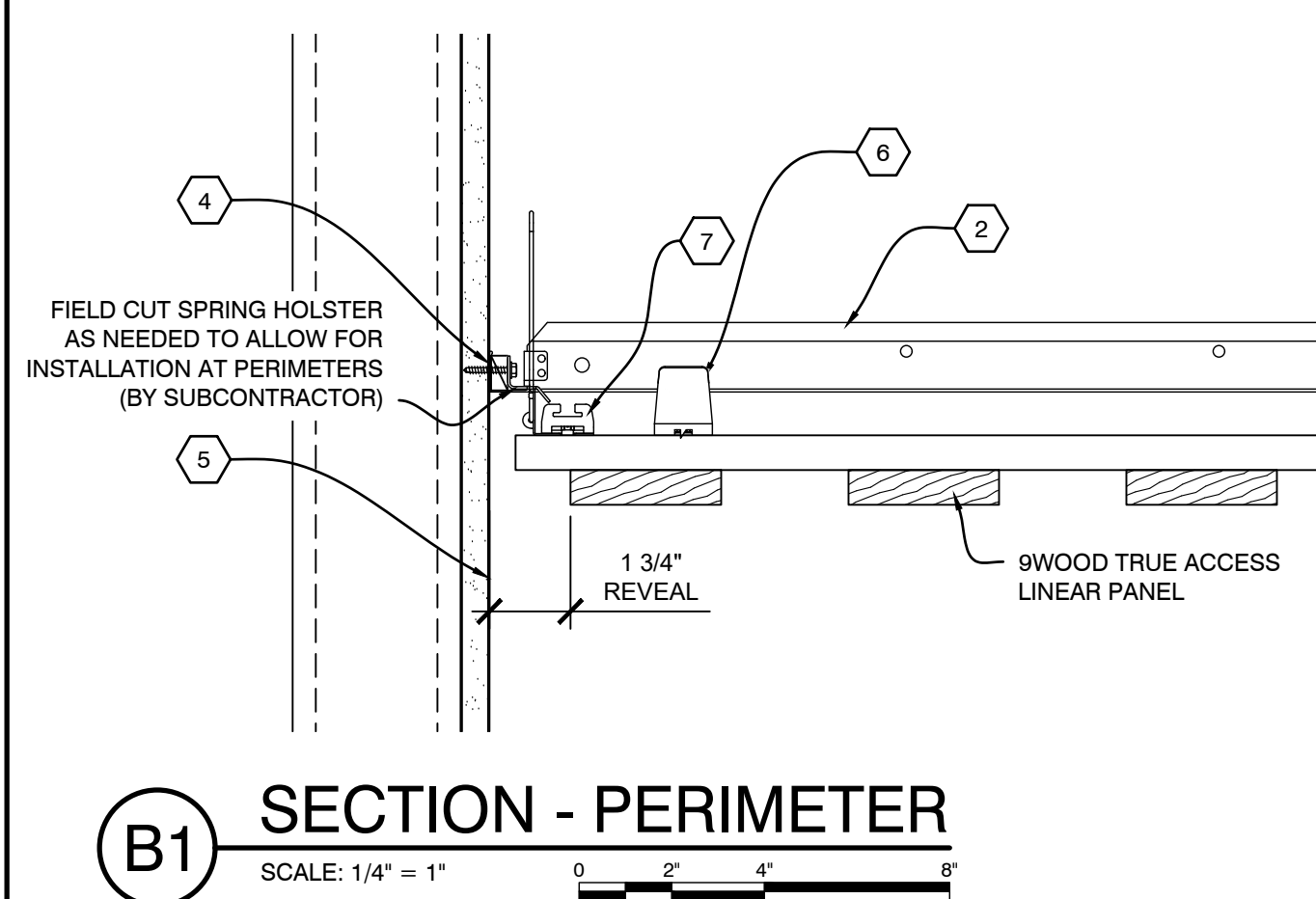

B1 SECTION - PERIMETER

SCALE: 1/4" = 1"

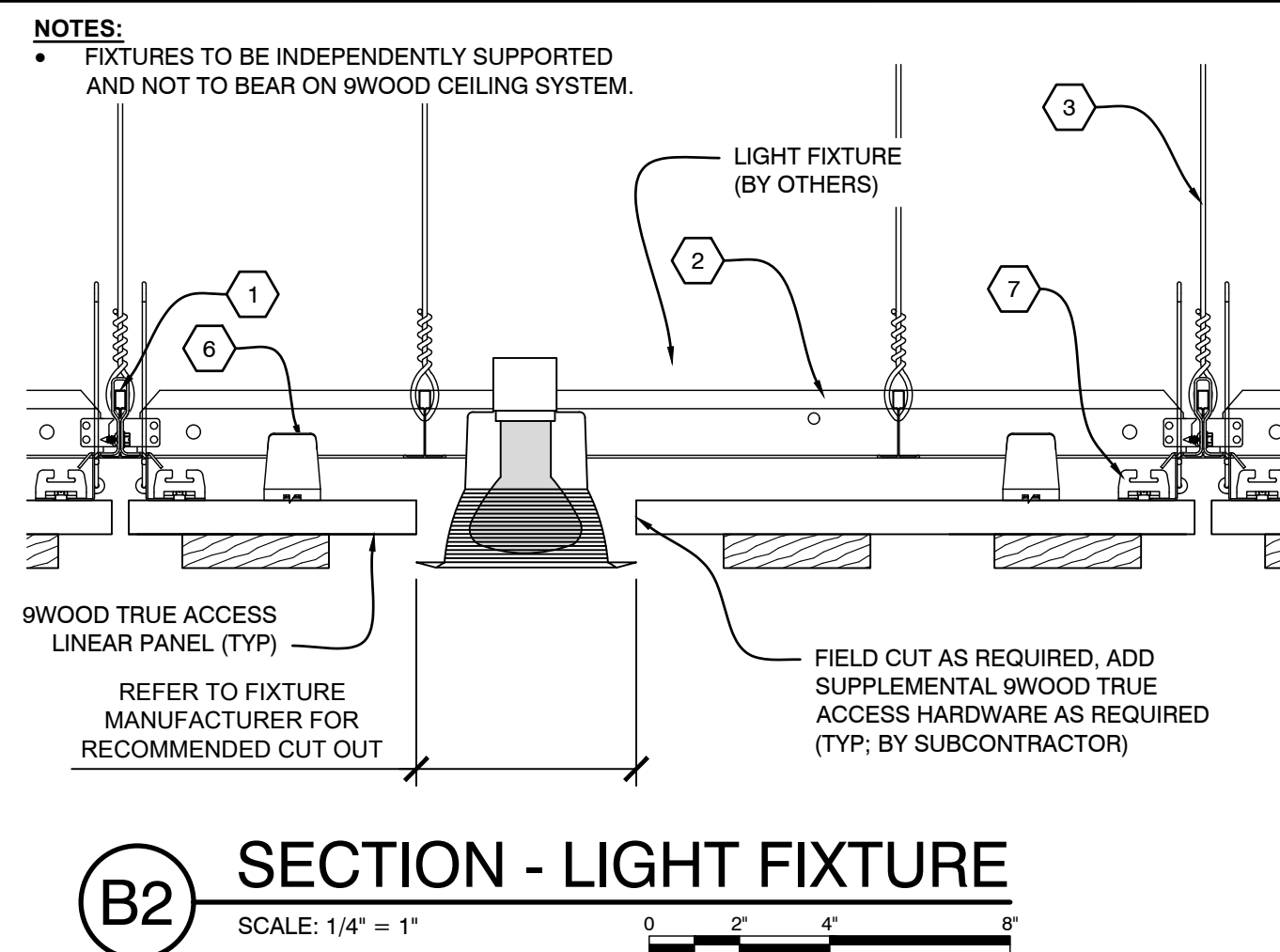

B2 SECTION - LIGHT FIXTURE

SCALE: 1/4" = 1"

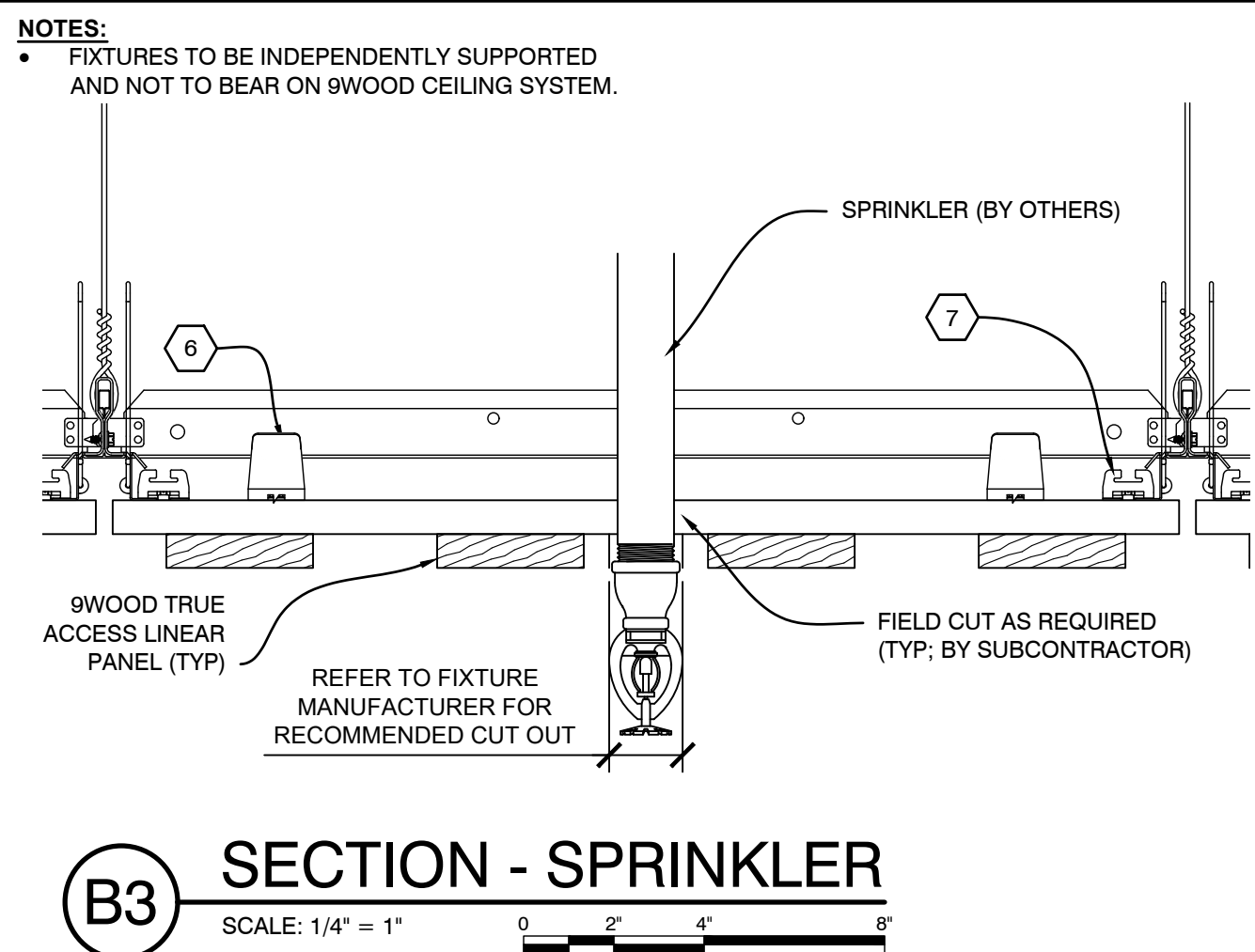

B3 SECTION - SPRINKLER

SCALE: 1/4" = 1"

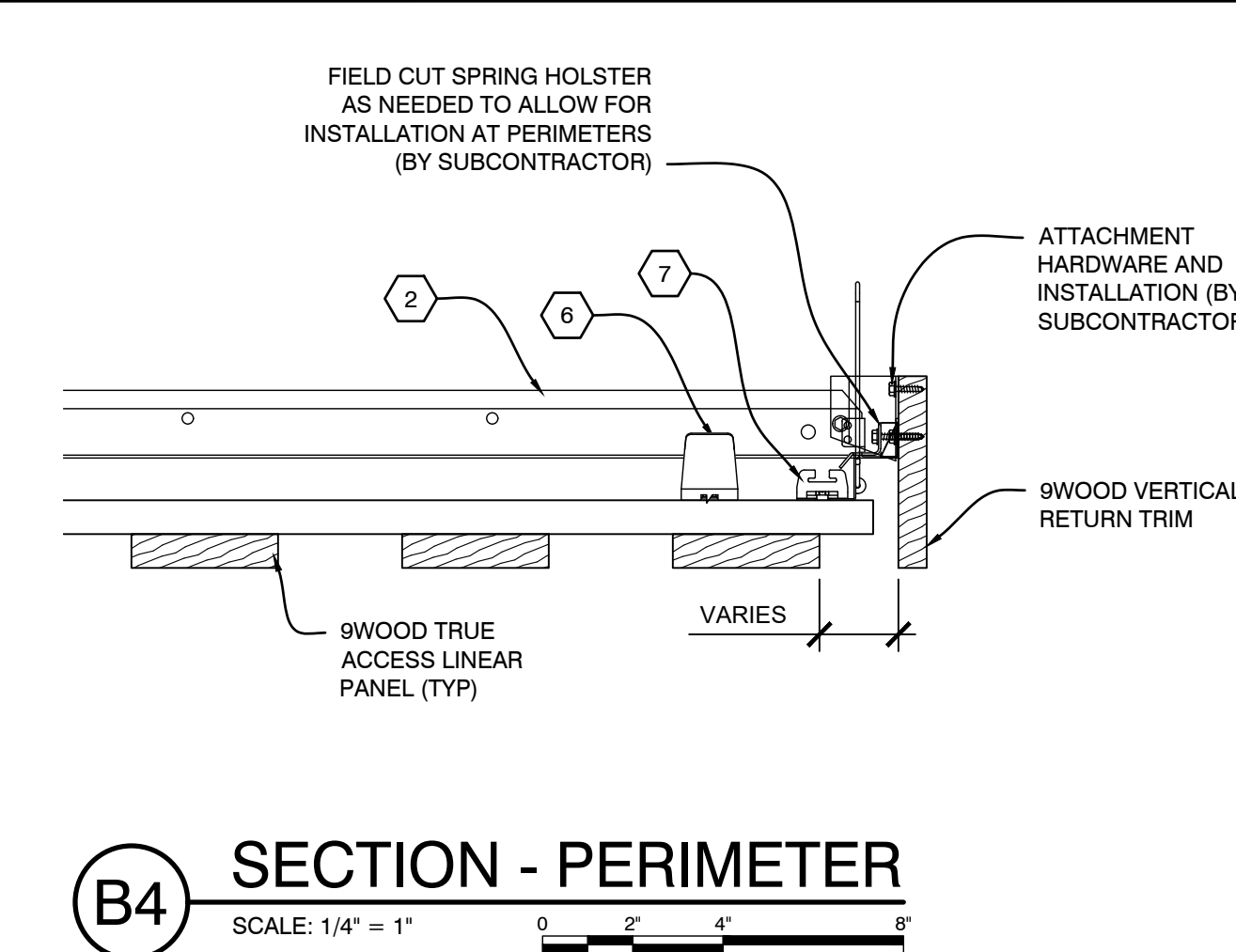

B4 SECTION - PERIMETER

SCALE: 1/4" = 1"

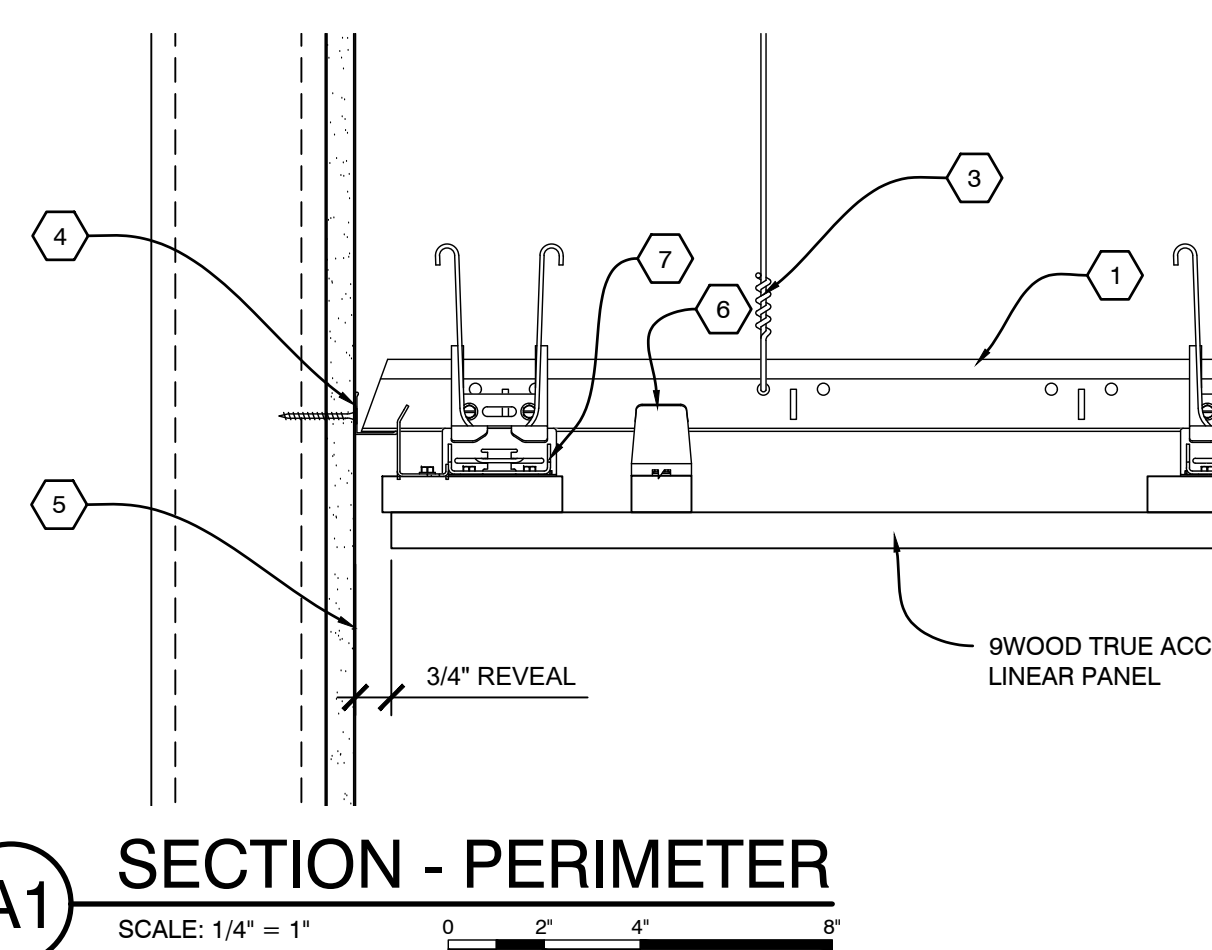

A1 SECTION - PERIMETER

SCALE: 1/4" = 1"

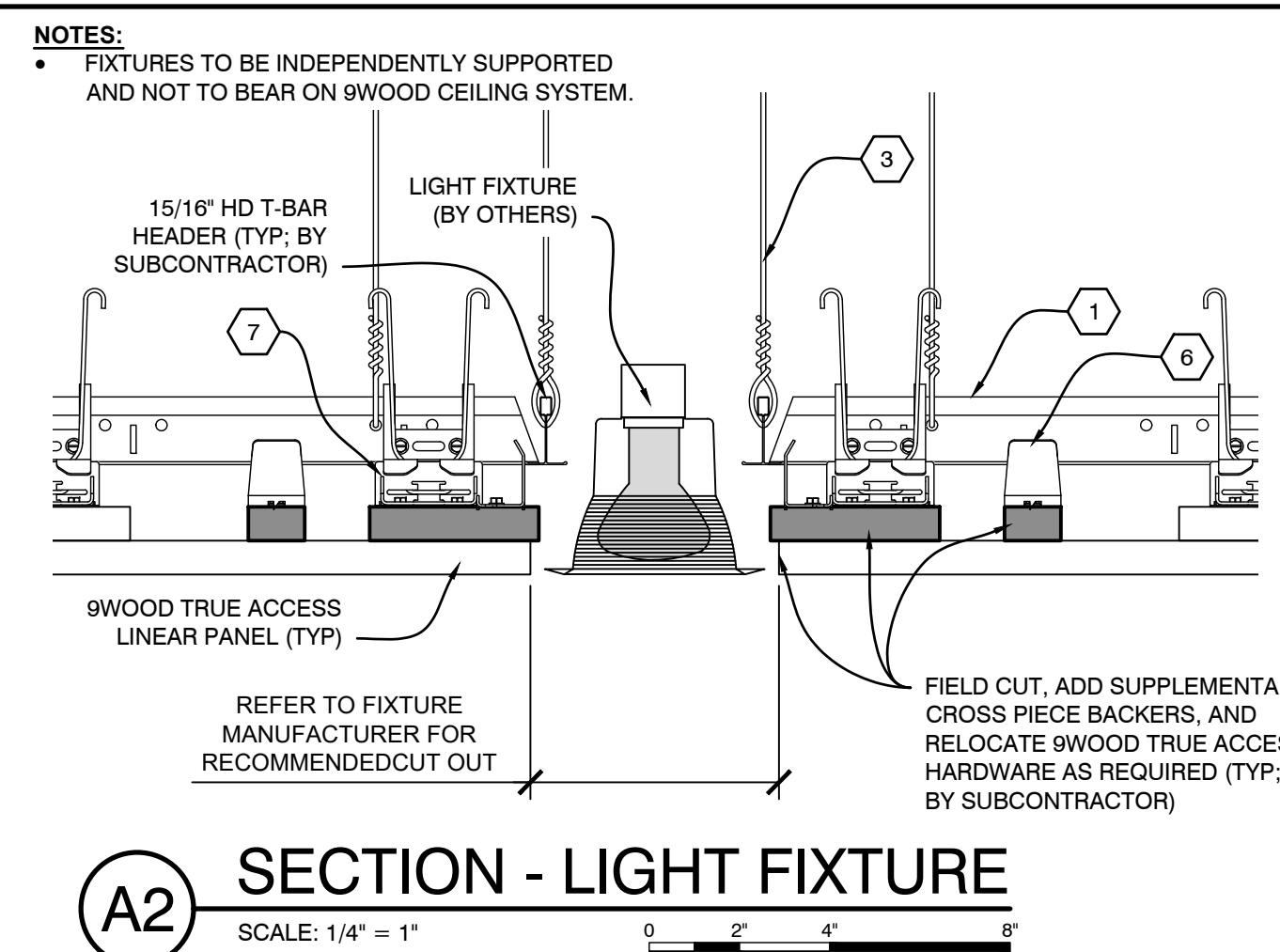

A2 SECTION - LIGHT FIXTURE

SCALE: 1/4" = 1"

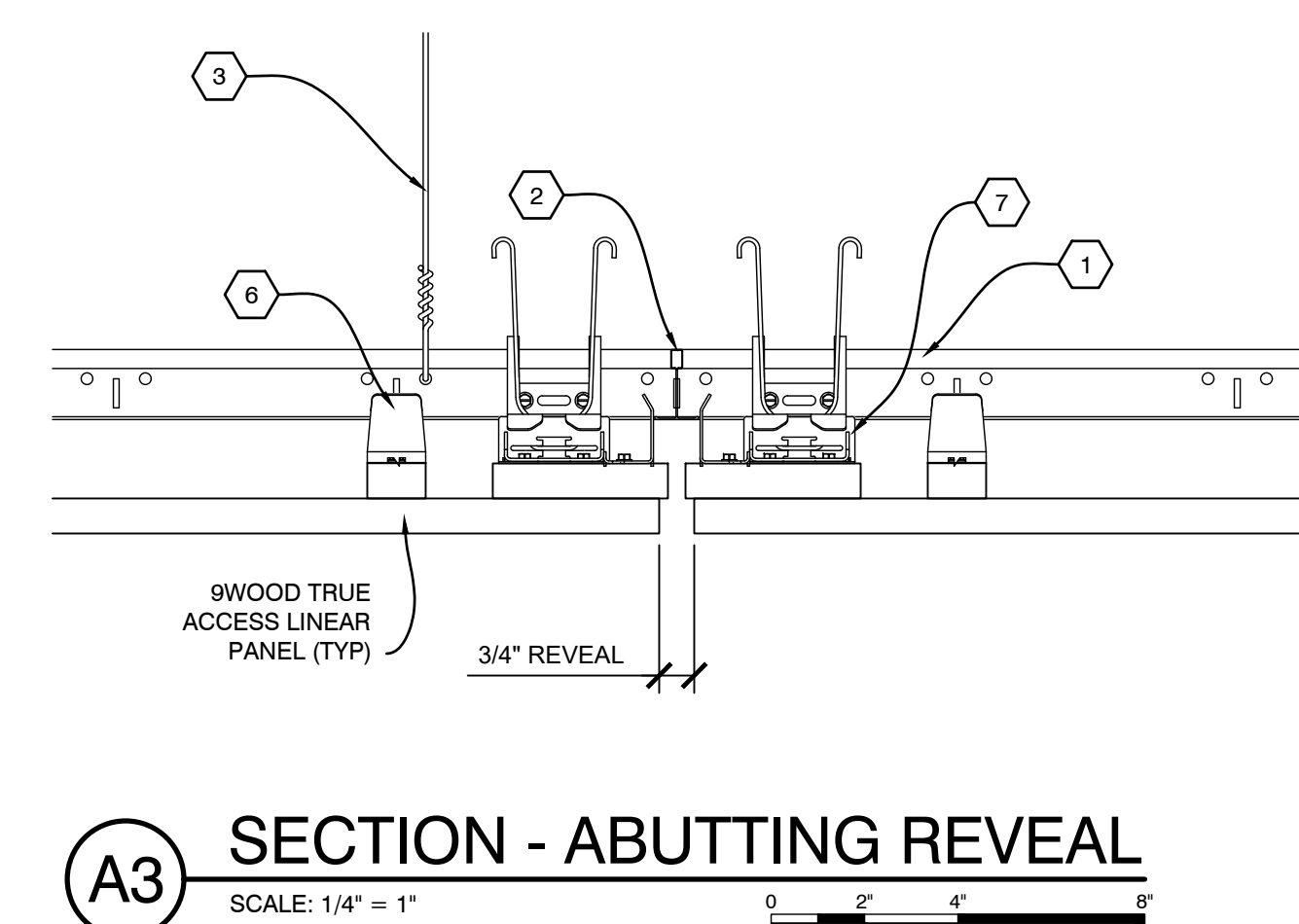

A3 SECTION - ABUTTING REVEAL

SCALE: 1/4" = 1"

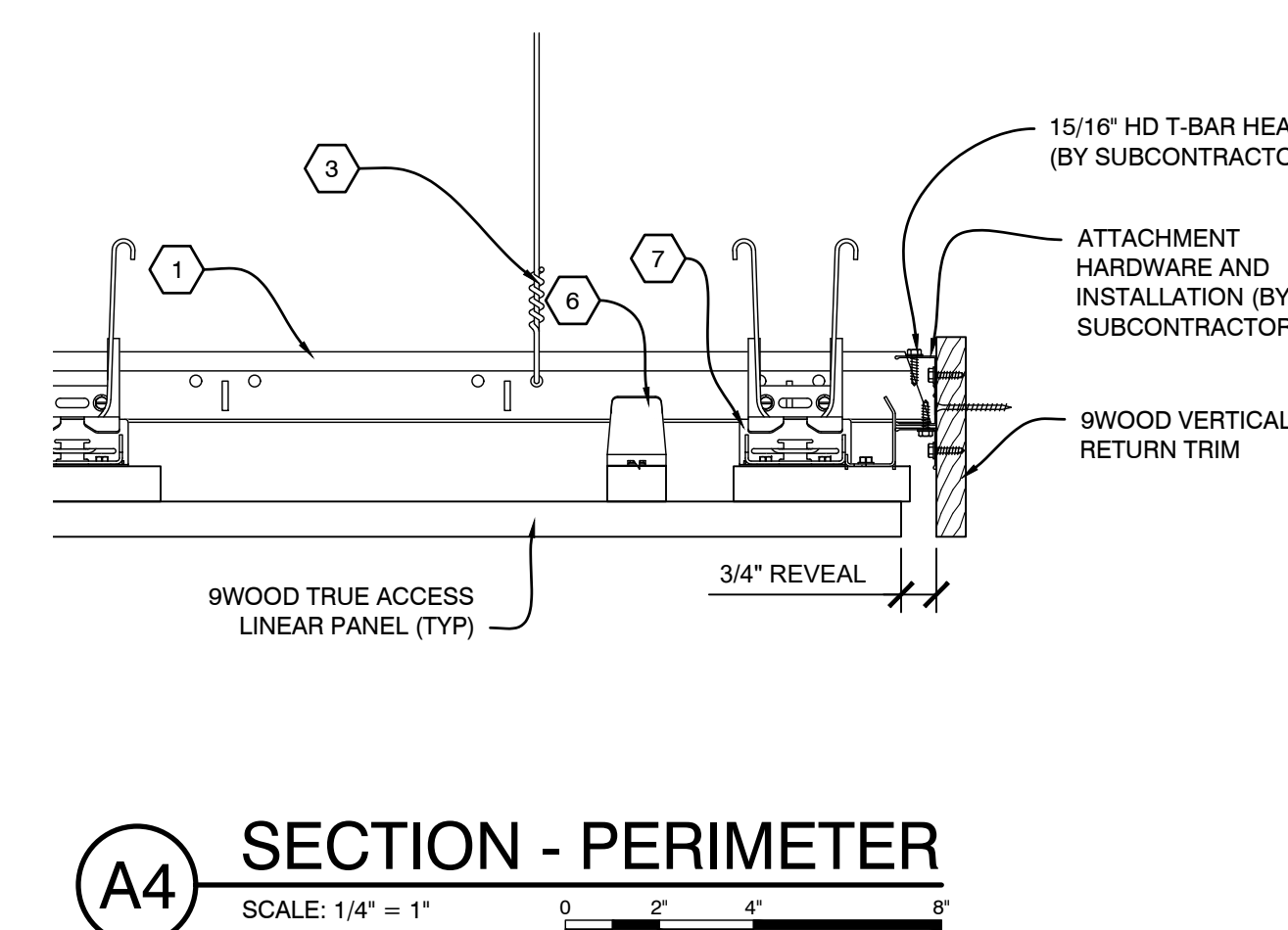

A4 SECTION - PERIMETER

SCALE: 1/4" = 1"