

Low-Level Sensing Systems

Cartridge Holders or 1-Gallon Bottle Drop-In
Tanks with Low-Level Sensor Systems
User Guide

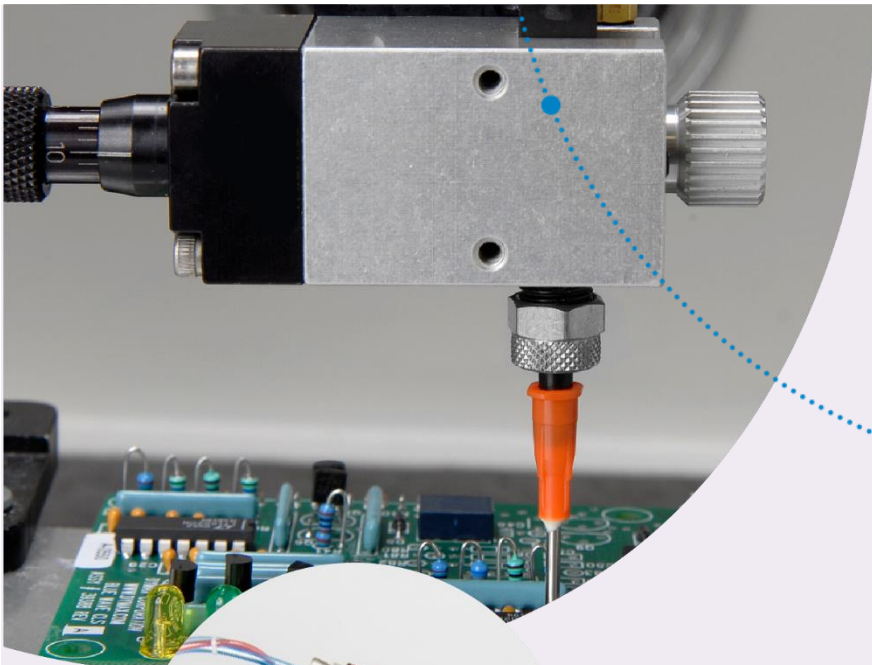



About Dymax

UV/Visible light-curable adhesives. Systems for light curing, fluid dispensing, and fluid packaging.

Dymax manufactures industrial, light-curable, epoxy, and activator-cured adhesives. We also manufacture a complete line of manual fluid dispensing systems, automatic fluid dispensing systems, and light-curing systems. Light-curing systems include LED light sources, spot, flood, and conveyor systems designed for compatibility and high performance with Dymax adhesives.

Dymax adhesives and light-curing systems optimize the speed of automated assembly, allow for in-line inspection, and increase throughput. System designs enable stand-alone configuration or integration into your existing assembly line.

Please note that most dispensing and curing system applications are unique. Dymax does not warrant the fitness of the product for the intended application. Any warranty applicable to the product, its application, and use is strictly limited to that contained in the Dymax standard Conditions of Sale. Dymax recommends that any intended application be evaluated and tested by the user to ensure that desired performance criteria are satisfied. Dymax is willing to assist users in their performance testing and evaluation by offering equipment trial rental and leasing programs to assist in such testing and evaluations. Data sheets are available for valve controllers or pressure pots upon request.

Contents

Introduction.....	4
Where to Get Help.....	4
Safety.....	4
General Safety Considerations.....	4
Specific Safety Considerations.....	4
1-Gallon Tank Potential Hazards.....	5
Product Overview.....	7
Description of the Dymax Low-Level Sensing System.....	7
Utilities Required.....	8
Main System Components.....	8
Unpacking.....	11
Unpacking and Inspecting Your Shipment.....	11
Parts Included with Cartridge Holder Systems.....	11
Parts Included with 1-Gallon Tank Systems.....	11
Sensor Set Up & Operation - Cartridge Holder Systems.....	11
Setting the Sensor Indication Level.....	11
Replacing the Cartridge.....	13
Sensor Setup & Operation – 1 Gallon Tank Systems.....	13
Connecting Air Regulators and Material Line to the Tank Cover.....	14
Connecting Material Outlet Tube.....	15
Installing Pressure Plate Sensor Assembly.....	15
Setting Low-Level Indication Level.....	16
Inserting the Bottle Reservoir into the Tank.....	17
1-Gallon Upgrade Kit Installation.....	17
SB-100 Controller Setup.....	20
Connecting the Sensor to the SB-100 Controller.....	20
SB-100 Function Options.....	22
Cleaning & Maintenance.....	24
System Cleaning.....	24
Periodic Sensor Maintenance.....	24
Troubleshooting.....	25
Spare Parts and Accessories.....	26
Specifications.....	26
Declaration of Conformity.....	27
Warranty.....	30

Introduction

This guide describes how to use Dymax Low-Level Sensing Systems. Sections in this guide describe how to assemble, use, and maintain the equipment safely and efficiently.

Intended Audience

Dymax prepared this user guide for experienced process engineers, technicians, and manufacturing personnel. If you do not understand the instructions, contact Dymax Application Engineering to answer your questions before using the equipment.

Where to Get Help

Dymax Customer Support and Application Engineering teams are available in the United States, Monday through Friday, from 8:00 a.m. to 5:30 p.m. Eastern Standard Time. You can also email Dymax at info@dymax.com. Contact information for additional Dymax locations can be found on the back cover of this user guide.

Additional resources are available to ensure a trouble-free experience with our products:

- Detailed product information on www.dymax.com
- Dymax adhesive Product Data Sheets (PDS) on our website
- Safety Data Sheets (SDS) provided with shipments of Dymax adhesives

Safety



WARNING! *If you use this equipment without first reading and understanding the information in this guide, personal injury can result from the uncontrolled release of high-pressure gas, injection, or exposure to chemicals. To reduce the risk of injury, read and understand this guide before assembling and using the Dymax fluid dispensing system.*

General Safety Considerations

All users of Dymax equipment systems should read and understand this user guide before assembling and using the system.

To learn about the safe handling and use of dispensing fluids, obtain and read the Safety Data Sheet and handling requirements for each fluid before using the fluid. Dymax includes a Safety Data Sheet with each adhesive we sell. You can also request Safety Data Sheets for our products on our website.

Specific Safety Considerations

Using Safe Operating Pressures

Pressurizing the components in the dispensing system beyond the maximum recommended pressure can result in the rupturing of components and serious personal injury. To minimize the risk of rupturing components and injury, do not exceed the maximum operating pressure of the components in your fluid dispensing system. (See system specifications)

Replacing System Parts

When replacing system parts, ensure the quality of replacement parts matches the quality of the original equipment parts to maintain the safety and operational performance of the system.

1-Gallon Tank Potential Hazards

Equipment Misuse



WARNINGS! This equipment is for professional use only. Serious injury can result from high-pressure fluids. To reduce the risk of injury, read and ensure you understand the information in this user guide before assembling and operating the Dymax pressure tank.



Read all instructions before operating the equipment. Use the equipment for its intended purpose only. If you are uncertain about usage, call Dymax Application Engineering before continuing. Improper use such as modifying or removing parts, using incompatible materials, over pressurizing the equipment, or using worn/damaged/incompatible parts can result in serious bodily injury.

Do not alter or modify this equipment in any way. If worn parts need to be replaced, use only Dymax parts and accessories.

Inspect all equipment components daily. Repair or replace any worn or damaged parts immediately. Do not use the equipment until all worn or damaged parts have been replaced.

Use materials which are compatible with the equipment's wetted parts. Reference the material manufacturer's warnings. If you are unsure about material compatibility, contact Dymax Application Engineering.

Do not exceed the maximum working pressure of the lowest rated system component. This pressure tank has a 60 psi (410 kPa, 0.41 MPa, 4.1 bar) maximum working pressure. Check the rating on all dispensing equipment and accessories to ensure they can withstand the operating pressure of the reservoir.

Never use 1.1.1 – trichloroethane, methylene chloride, or other halogenated hydrocarbon solvents or fluids containing such solvents in pressurized aluminum equipment. Use in pressurized equipment could result in a chemical reaction, with the possibility of explosion. Comply with all applicable fire, electrical, and safety regulations.

Tipping and Dropping



WARNINGS! Place the equipment on a sturdy, level surface. Check that all tubing lengths are long enough to allow for unrestricted movement of the system components. Do not lift pressurized equipment. If the equipment needs to be moved, do not pull on the tubing to move the reservoir.



Do not tip the reservoir or place it on its side. Fluid can enter and damage the pressure regulator and the pressure relief valve leading to an over-pressure condition within the reservoir. Once the pressure regulator and/or pressure relief valve become blocked, they must be replaced with new Dymax parts before the equipment can be operated again.

Do not drop the pressure tank. Dropping a pressure tank from any height can damage the pressure relief valve, pressure regulator, fittings, reservoir body, or cover. A damaged pressure regulator or damaged pressure relief valve may lead to an over-pressure condition within the reservoir while a damaged reservoir body or cover can lead to an explosion. If your reservoir is dropped, it must be thoroughly inspected for any cracks or damage to the pressure regulator and/or pressure relief valve. Any damaged parts must be replaced with Dymax parts before the equipment can be operated again. If you are unsure about the condition of your tank, please contact Dymax.

Tubing



WARNINGS! Pressurized tubing can be very dangerous. Worn, damaged, or misused tubing can develop a leak, spraying the contents of the tank at high pressure. Materials can be sprayed into eyes or onto skin causing serious bodily harm. Fire and other property damage can also occur from unwanted spraying.



Before pressurizing the system, make sure all fluid connections to the tank are secure and route tubing away from traffic areas, sharp edges, moving parts, and hot surfaces.

Inspect all tubing for cuts, leaks, or other damage and replace any damaged tubing immediately.

Check that the material being dispensed is compatible with the tubing material. Contact Dymax Applications Engineering if you are unsure of tubing/material compatibility.

Do not expose tubing to operating temperatures above 50°C (122°F) or below 0°C (32°F).

Pressurized Equipment



WARNINGS! Ruptured components in pressurized systems can spray or splash materials on the skin or in the eyes causing serious injury. Do not try to stop or repel fluid leaks with your hand, body, glove, or rag. In the event of a ruptured component, stop work immediately, close tank inlet valve, depressurize the tank, and disconnect the air supply. Any damaged parts must be replaced with Dymax parts before the equipment can be operated again.



Follow the pressure relief procedure whenever you are instructed to relieve the pressure, stop dispensing, clean, check, or service equipment, or install or clean the fluid nozzle.

Tighten all the fluid connections before operating the equipment.

Inspect the fluid line tubing and couplings daily for damage or wear. Replace worn, damaged, or loose parts immediately.

Fire and Explosion (For Spraying Applications)



WARNINGS! Ground all equipment in the work area. Improper grounding, poor ventilation, open flames, or sparks can cause hazardous conditions and result in a fire, explosion, or other serious injury.



If static sparking occurs or an electric shock is felt while using the equipment, stop spraying immediately. Do not use the equipment until you identify and correct the problem.

Always work in a well-ventilated area. Some materials give off flammable fumes or vapors. Upon buildup, these fumes can result in a fire or explosion.

Keep the work area free of debris (i.e. solvents, rags, gasoline). Always keep a fire extinguisher compatible with your equipment and processes in the work area in case of fire.

Electrically disconnect all the equipment in the spray area and extinguish all open flames or pilot lights.

Do not smoke in the work area.

Do not turn on or off any light switch in the work area while operating or if fumes are present.

Do not operate a gasoline engine in the work area.

Chemical



WARNINGS! Hazardous chemicals can give off fumes that can cause serious injury or death if inhaled, swallowed, or splashed in the eyes or on the skin. Wear respiratory protection and protective eyewear, gloves, and clothing. Consult the chemical manufacturer for recommended personal protective equipment and hazards specific to the chemical being used.



Fumes may contain both gases (vapors) and dust (smoke given off by a substance as a result of a chemical transformation).

Consult the Material Safety Data Sheet (MSDS) or Safety Data Sheet (SDS) for all chemical products you are using prior to commencing work.

Store hazardous chemicals in approved containers.

Dispose of hazardous chemicals according to all local, state, and federal regulations.

Product Overview

Description of the Dymax Low-Level Sensing System

Dymax low-level detection systems allow users to accurately monitor material levels during the dispensing process with an adjustable sensor mount. The level sensors are intended to be used with pressurized reservoirs. Two sensor system configurations are available allowing integration into cartridge holders (cartridge reservoirs) or 1-gallon tanks (pressure pot material reservoirs, bottle drop-in tanks). Both configurations feature an SB-100 controller which activates a warning (beacon and/or buzzer) when the material level in the reservoir reaches a specified low level. The SB-100 controller also features an external PLC connection that allows for a total line shut-down. Both functions save time and money by stopping the dispensing system when material is empty. Each sensor configuration is adjustable, allowing users to set specific levels of material to signal warning and automatic shut-off options.

Features & Benefits

Features	Benefits
No wetted components, sensor does not contact fluids	Level sensor is compatible with wide range of materials
Accurate sensor detection (Hysteresis = +/- .5%)	Dependable repeatability of accurate sensing level
Easy adjustment	Greater dispensing accuracy with quick level setting
SB-100 smart monitor	Low electrical power required Prevents air from entering fluid lines
Easy access to sensors	Ergonomic, accessible sensor locations for quick adjustment & visual verification of placement

Utilities Required

The level sensing system is designed to work within pressurized containers up to 100 psi (6.9 bar) as well as freestanding containers. The sensors and SB-100 controller is complete with power supply.

Power Source Specs:

Input range: 100-240V ~, 50-60Hz, 0.6A

Output: 24V ---- 0.75A

Main System Components

SB-100 Controller

The SB-100 controller interface controls power on/off, auto-shut down auxiliary jack, internal audio alarm, and external beacon alarm. Each setting is simply controlled as an on/off function by pressing on the appropriate button. When a button is in the on position, the LED indication light above the button will be illuminated. When the material level reaches the set low point, the LED light in the top right corner of the controller will turn on automatically.

Figure 1.
SB-100 Controller

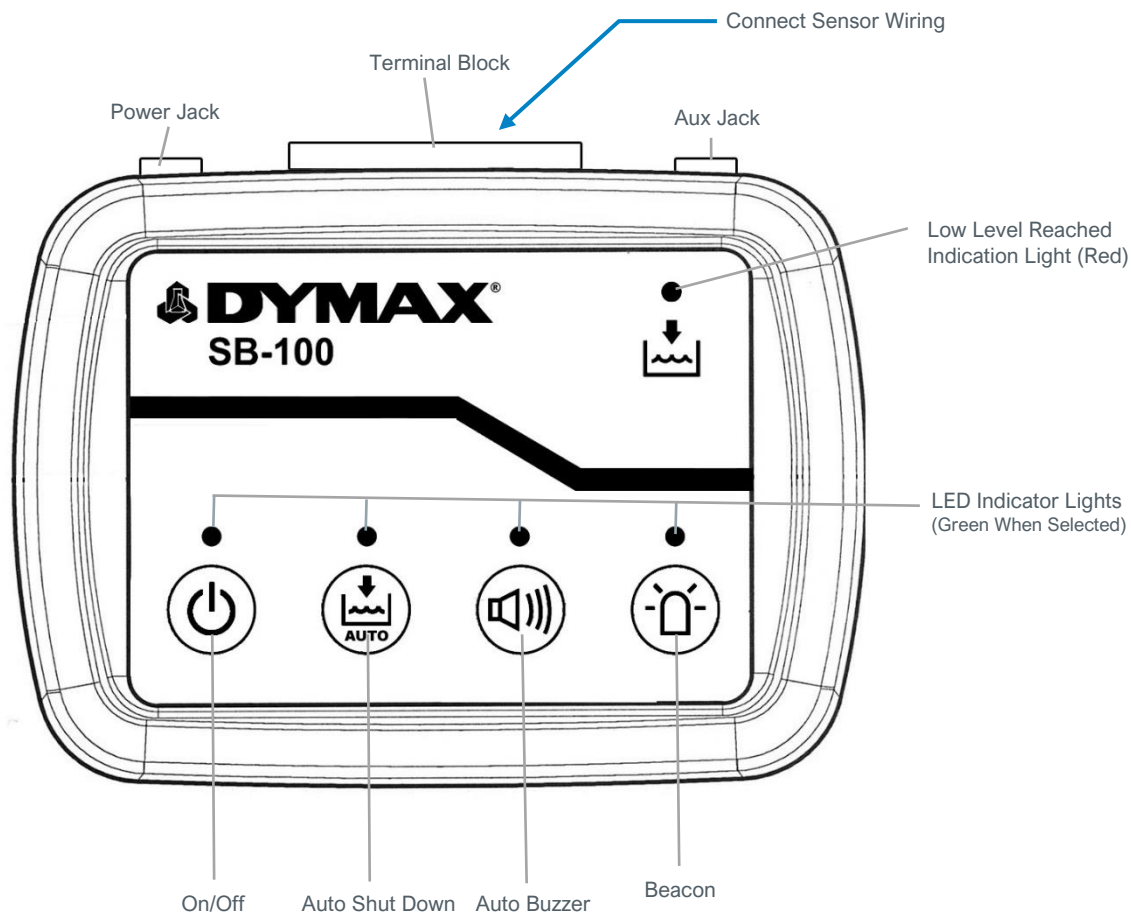

Cartridge Holder Assembly

A cartridge holder assembly consists of a cartridge holder (a metal cartridge retainer) and a cartridge (a polyethylene cartridge reservoir). The cartridge holder cover seals the top of the cartridge holder. The bottom of the cartridge holder includes a hole for the outlet port of the cartridge. Pressurizing the top of the cartridge holder pushes the cartridge piston down, which pushes the fluid from the outlet port.

The cartridge holder is supplied in several sizes but the design features of each are similar. Each cartridge holder includes one empty, disposable cartridge that can be filled with fluid for dispensing.

Level-sensing cartridge holders accept the same cartridges as standard cartridge holders. A sensor is seated in a bracket attached directly onto the lower portion of the cartridge holder, or to a mounting bracket. The sensor is adjustable within this bracket or up and down the cartridge holder. Once set at a desired position, the sensor detects when fluid level passes by the detection point and triggers audio and visual warnings through the SB-100 controller. The controller can also be set to automatically shut down a production line if the cartridge is empty.

Figure 2.
Cartridge Reservoir Assembly with Low-Level Sensor

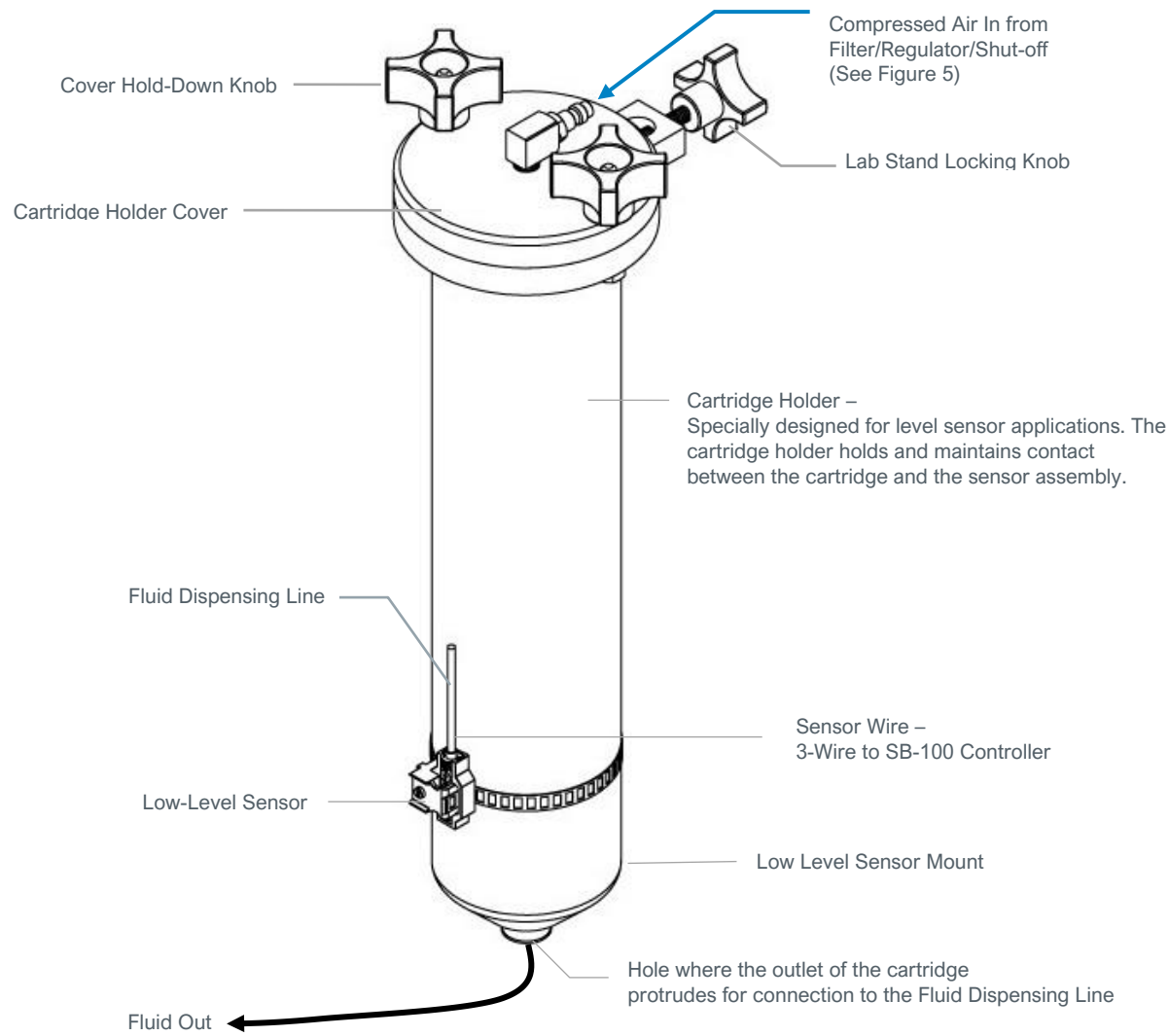

1-Gallon Bottle Drop-In Tanks

1-gallon tanks (1-gallon bottle drop-in material reservoirs) include a push-through fitting on the tank cover where a fluid dispensing line is pushed directly through the fitting and into the tank to form a draw tube. When the tank is pressurized, the fluid is pushed up the tube and into the fluid dispensing line. A precision air regulator is permanently attached to the cover of the tank for easy monitoring of pressure.

Level sensing is achieved with the addition of a pressure plate that rests on the bottom of the tank. When material in the bottle reaches a certain level/weight, the sensor will send a signal to the SB-100 controller, notifying the user that material level is low.

Figure 3.
1-Gallon Tank with Low-Level Sensor

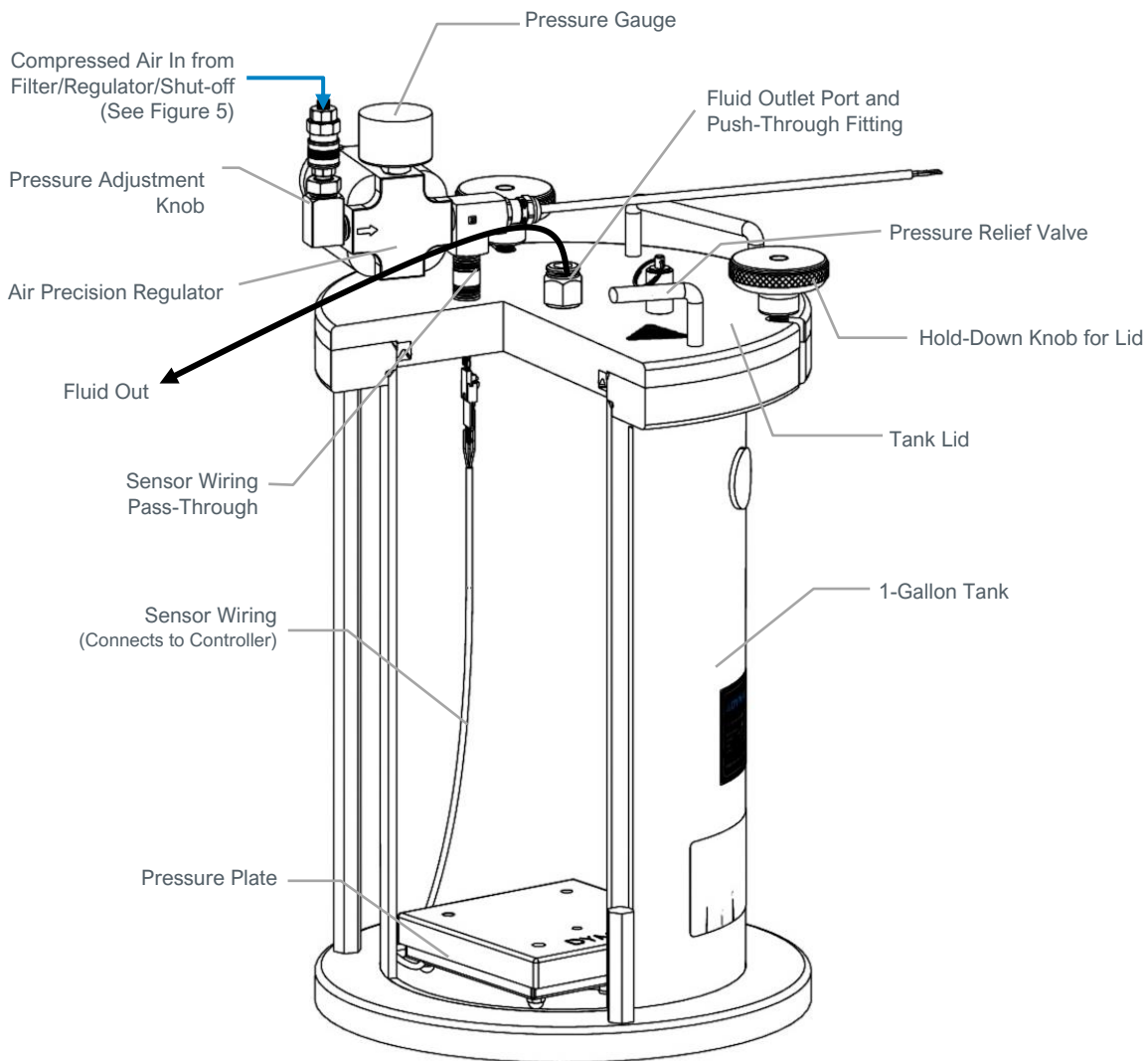

Unpacking

Unpacking and Inspecting Your Shipment

When your low-level sensing system arrives, inspect the box for damage and notify the shipper of box damage immediately.

Open the box and check for equipment damage. If parts are damaged, notify the shipper and submit a claim for the damaged parts. Contact Dymax so that new parts can be shipped to you immediately.

Check that the parts included in your order match those listed below. If parts are missing, contact your local Dymax representative or Dymax Customer Support to resolve the problem.

Parts Included with Cartridge Holder Systems

- Cartridge holder with sensor (6 oz., 12 oz., 20 oz., or 32 oz.)
- SB-100 controller
- Power supply (100-240V ~, 50-60Hz, 0.6A)
- Remote beacon
- Aux jack cable
- User guide

Parts Included with 1-Gallon Tank Systems

- 1-Gallon bottle drop-in tank with pass through (fits 0.26-gallon (1-L) and 0.5-gallon (2-L) bottles or 0.26-gallon (1-L), 0.5-gallon (2-L) and 1.0-gallon (3.78-L) bottles)
- SB-100 controller (packed inside the reservoir)
- Plate sensor assembly
- Power supply (100-240V ~, 50-60Hz, 0.6A)
- Remote beacon
- Aux jack cable
- User guide

Sensor Set Up & Operation - Cartridge Holder Systems

Assembling a cartridge holder system involves setting the appropriate sensor indication level and determining the level of logic and function required for the SB-100 controller.

Setting the Sensor Indication Level

1. Locate an appropriate place to operate your sensor system. The SB-100 Controller should be mounted in an area that is easy to access and where there is a clear line of sight to the Warning Beacon.

NOTE: *Keep in mind the wire routing between the Cartridge Holder, SB-100 Controller, and Warning Beacon when selecting your location.*

2. With the Cartridge Holder and Sensor in place, insert a Cartridge of material into the Cartridge Holder.

NOTE: *Some prefilled cartridges are protected with a cap on the piston side (large end). The cap must be removed for proper operation of the cartridge holder.*

3. Seal the Cartridge Holder Cap and attach the Fluid Outlet Tube to a controlled Dispense Valve.
4. For capacitive sensor systems, ensure the Sensor is pressing tightly against the plastic cartridge wall. Without physical contact, the capacitive sensor will not be able to read the material level in the cartridge. For magnetic sensor systems, ensure the sensor bracket is tight against the cartridge holder to maintain the locked position.

Figure 4.
Capacitive/Magnetic Sensor & Adjustment Bracket on Cartridge Holder

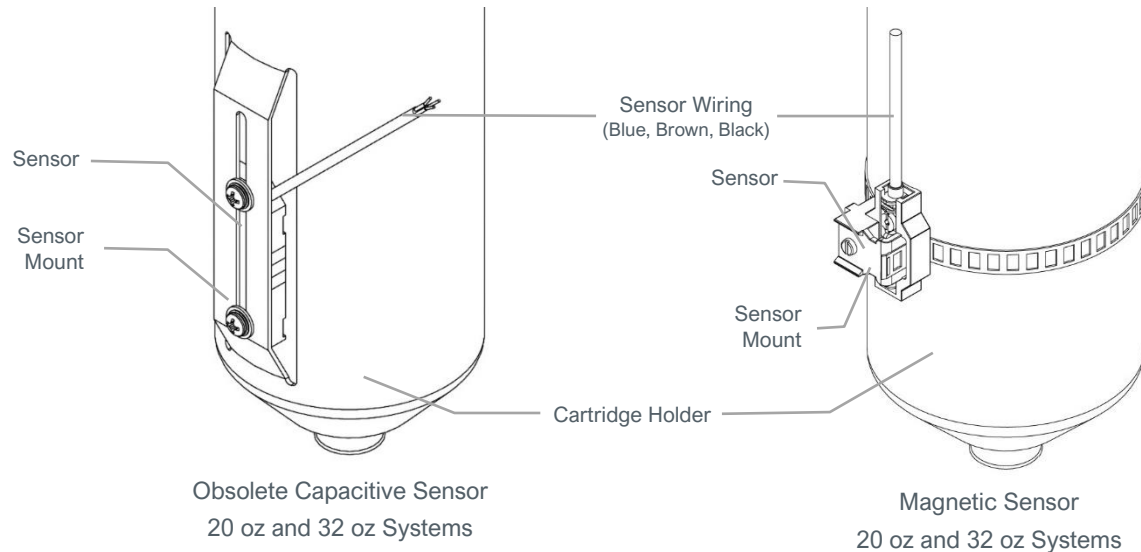

5. Depending on the rate and speed at which materials are being dispensed, adjust the height of the Sensor within the Sensor Bracket or on the Cartridge Holder (Figure 4) so that it will provide enough warning time for operators. The higher the Sensor is mounted in the Bracket or on the cartridge holder, the more time an operator must react before the Cartridge runs out of material. Setting the Sensor at the lowest point in the Bracket or on the cartridge holder will result in minimal time between the warning and the Cartridge reaching empty.
6. Connect the Power Supply to the SB-100 Controller. (See SB-100 Controller Setup, page 17)
7. Connect the Sensor Wiring to the SB-100 Terminal Connections. (See SB-100 Controller Setup, page 17)
8. Turn the SB-100 Controller on and adjust the warning functions to those preferred during operation. (See SB-100 Controller Setup, page 17)
9. Perform an initial trial. Dispense material until the level passes the Sensor to ensure the warnings are working properly.
10. Evaluate the time between the sensor indication and the container becoming completely empty. Adjust the sensor indication levels as necessary (repeat Step 5 to adjust the sensor height and evaluate indication preferences).

NOTE: For the 6 oz. (160 mL) and 12 oz. (300 mL) cartridges, the sensor can be set to about 0.75 oz. (22 mL) to 1.75 oz. (55 mL) remaining. For the 20 oz. (550 mL) and 32 oz. (900 mL) cartridges, the sensor can be set to about 4.3 oz. (130 mL) to 7.2 oz. (210 mL) remaining.

Replacing the Cartridge



WARNING! Some Dymax fluids can bond skin together in seconds. It can also irritate skin, eyes, and mucous membranes. To minimize the risk of bonded skin or irritation, wear protective gloves and eyewear when working with Dymax fluids and the hand-held spray gun system.

1. Remove the Cover from the Cartridge Holder by loosening the Cover Hold-Down Knobs. Remove the empty Cartridge if present.
2. For magnetic sensor systems, also remove magnet for the top of the piston and set aside.
3. Remove the Cap protecting the Piston from the new Cartridge.

NOTE: Some prefilled cartridges are protected with a cap on the piston side (large end). The cap must be removed for proper operation of the cartridge holder.

4. Place the new Cartridge in the Cartridge Holder so that the Fluid Outlet at the bottom of the Cartridge extends through the hole in the bottom of the Cartridge Holder.
5. For magnetic sensor systems, insert magnet on top of the new piston.
6. Install the Cover on the Cartridge Holder and tighten its Hold-Down Knobs.
7. To prevent low-viscosity fluids from flowing out of the Cartridge when the Outlet Plug is removed, remove the Cartridge Holder from the Lab Stand and hold the Cartridge Holder upside down.
8. Unscrew and remove the Plug from the Cartridge Outlet.
9. Screw the ¼ NPT to 3/8" (9.5 mm) OD Tube Fitting into the Cartridge Outlet until it is just snug, then turn it about one additional half turn.

NOTE: PTFE pipe thread tape should be on the threads of the 3/8" (9.5 mm) fitting. If the fitting does not have thread tape installed (or you are reusing the fitting), apply fresh thread tape to prevent fluid leaks.

The ¼ NPT to 3/8" (9.5 mm) OD tube fitting is specially designed to fit the Cartridge Outlet. The bottom three threads are machined from the fitting. Using a standard fitting in place of the Dymax-supplied fitting will split the Cartridge Outlet Port and lead to fluid leaks. Use only the Dymax-supplied fitting on the Outlet Port of a Cartridge.

For optimal dispensing performance, the length of all fluid lines should be as short as possible to reduce fluid pressure drop and other variations that may affect precision dispensing.

Sensor Setup & Operation – 1 Gallon Tank Systems

Assembling the low-level pressure plate sensor into a tank system involves completing four main processes:

- Connecting all regulators, air lines, and fluid output tubing (Ref: Bottle Drop-In User Manual)
- Connecting the pressure plate sensor wiring to SB-100 controller through tank lid bulkhead fitting
- Setting preferred point for sensor low-level indication
- Inserting the pressure plate sensor and bottle reservoir in the tank

NOTES: Ensure that air lines are connected correctly at the inlets and outlets of the dispensing system components. The dispensing system will not function properly if connections are wrong.

Ensure that the bottle or container to be used in the 1-gallon tank does not exceed 12" in height.

Connecting Air Regulators and Material Line to the Tank Cover

1. Locate an appropriate place to operate your sensor system. The SB-100 Controller should be mounted in an area that is easy to access and where there is a clear line of sight to the Warning Beacon.

NOTE: Keep in mind the wire routing between the Tank, SB-100 Controller, and Warning Beacon when selecting your location.

2. Securely mount the Air Filter/Regulator in an upright position (Filter Bowl at the bottom) (Figure 5). Failing to securely mount the Air Filter/Regulator in the upright position will prevent regulator from removing moisture and particulates from the incoming compressed air.
3. Assemble the Quick-Disconnect Fitting supplied with the Tank onto a suitable length of 1/4" (6.3mm) OD tubing. Connect the free end to the Air Filter/Regulator's Outlet Port. Connect the quick-disconnect end to the Inlet Port on the Precision Air Regulator.
4. Ensure the Shutoff Valve on the Air Filter/Regulator is in the closed position.
5. Connect supply air to the Air Inlet on the Air Filter/Regulator.

Figure 5.
Air Filter/Regulator Connection

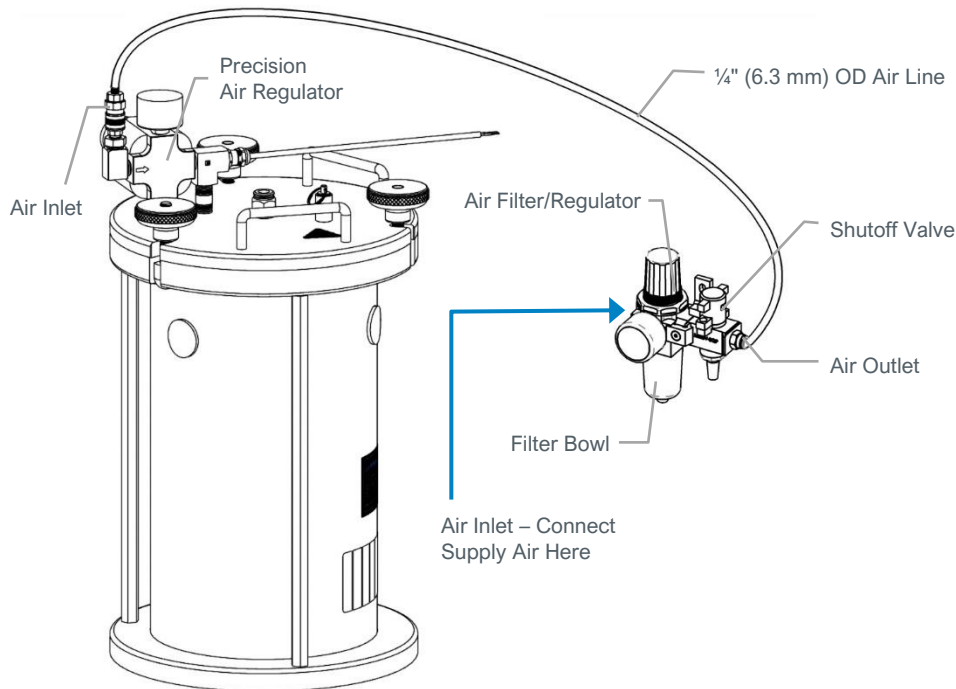

Connecting Material Outlet Tube

1. Insert the 3/8" (9.5 mm) OD material tubing through the push-through fitting on the top of the Tank Cover. Grab the tubing as it protrudes on the underside of the Tank Cover and pull the tubing through to form a Dip Tube. The Dip Tube should be of sufficient length to reach the bottom of the bottle or container when placed on the Level Sensor Plate. The exact distance from the Tank Cover to the Pressure Plate in the "at rest" position is 12.5" (31.75 cm).

IMPORTANT! Ensure tube is long enough to reach the bottom of the bottle without pressing downward on the bottle's bottom surface. If tube is cut too long, it will interfere with the Level Sensor Plate's function.

TIP: Cut the end of the tube at a 45° angle to ensure free flow of material at the bottom of the bottle.

2. Cut the other end of the Fluid Dispensing Line to a working length (6 ft. or less recommended). The dispensing line should be cut as short as possible to reduce pressure losses in the line, but long enough to enable you to reach and work comfortably in the work area.
3. Connect the Fluid Dispensing Line to dispensing equipment via press-fit or compression fitting.

NOTE: For optimal dispensing performance, the length of all fluid lines should be as short as possible to reduce fluid pressure drop and other variations that may affect precision dispensing

Installing Pressure Plate Sensor Assembly

1. Open the Tank and place the Pressure Plate Sensor Assembly inside. Rest it evenly on the bottom of the tank (Figure 6).
2. With the Tank Lid removed, connect the Sensor Wiring to the connector in the lid.

Figure 6.
Bottle Drop-In Tank Configuration

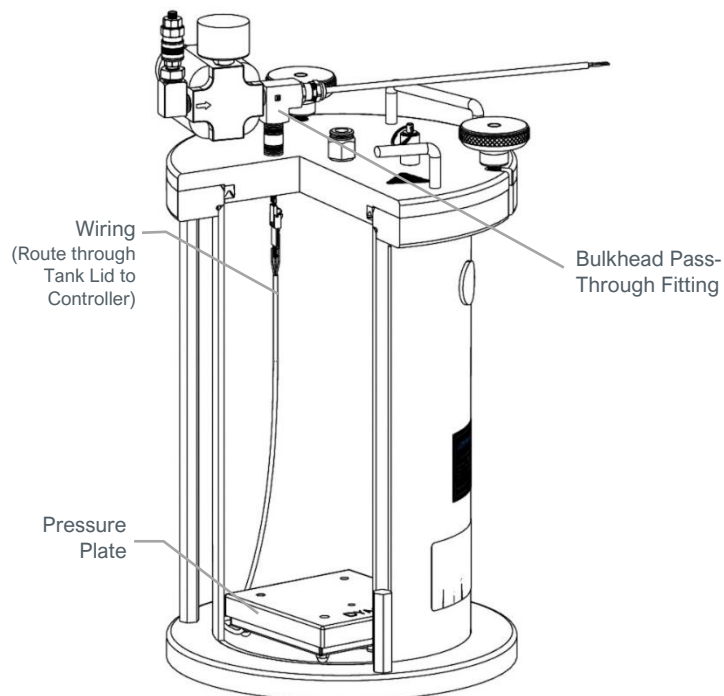

3. Strip the 1/4" wire ends and secure the connections to the SB-100 Controller. Ensure the Pressure Plate Sensor Connections are secure. (See SB-100 Controller Setup, page 17)

4. Connect the Power Jack, Beacon, and any external controls to the SB-100 Terminal Connections. (See SB-100 Controller Setup, page 17)

Setting Low-Level Indication Level

Calibrating the Sensor Plate requires adjusting the Sensor to the weight of the bottle when low-level indication is preferred. When bottle/container types or material changes are made, the Sensor must be re-calibrated to compensate for the new weight.

NOTES: *Calibrating can be done outside of the Tank. The Pressure Plate can be adjusted to trigger between 0-2 lbs. (0-900 g.)*

1. Place the Pressure-Plate Sensor on a level working surface near the Tank.
2. A similar sized bottle and water may be used for the initial setup instead of the intended bottle and material.
3. Slowly fill the empty bottle with material. Fill to the level representing “low” and where operators would prefer low-level indication to begin. (e.g. 1" of material in the bottom of the bottle).
4. Place the bottle on the Pressure-Plate Sensor. Make sure the bottle is centered and stable on the Pressure Plate’s surface.
5. Turn on power to the SB-100 Controller.
6. Turn on the Beacon and Buzzer Functions on the SB-100 Controller.
7. If no Buzzer/Beacon Signal is observed, loosen the locking screw and turn the Adjustment Dial (Figure 7) located on the side of the Pressure Plate to the left until the Sensor just turns on. Tighten lock screw to secure position.
8. If the Buzzer/Beacon Signal is observed, loosen locking screw and turn the Adjustment Dial to the right until the buzzer/beacon shuts off. Then turn the Adjustment Dial to the left until the Sensor just turns on. Tighten lock screw to secure position.
9. Confirm that the pressure pate has been set properly by lightly pushing down on the bottle. The buzzer/beacon should turn off. Let go of the bottle and the buzzer/beacon should turn back on.

Figure 7.
Pressure Plate Adjustment Knob/Wheel



10. Place the Tank in the location used during normal operation. Ensure the Tank is stable and level.
11. Place the Pressure-Plate Sensor in the bottom of the Tank. It should be secure, flat, level, and centered.
12. Place a new, full bottle containing product to be dispensed in the Tank. Make sure it is in the center of the Pressure-Plate Sensor. (See Next Section)
13. Install the Tank Lid ensuring the Sensor Wire is fully inside of the Tank and no pinching or kinking occurs. Be certain not to pinch the Sensor Wire between the Tank Lid and Body. (See Connecting Material Outlet Tube, page 15)

14. Secure the Tank Lid by tightening the Lid Hold-Down Knobs evenly to ensure uniform sealing.
15. With the SB-100 Controller on, adjust the functions to those preferred during operation. (See SB-100 Function Options, page 22)
16. Dispense normally. Evaluate the initial trial to determine the time between sensor indication and container reaching complete empty level. Adjust the sensor indication levels as necessary (repeat Steps 2 - 7 to adjust the sensor indication level).

Inserting the Bottle Reservoir into the Tank



WARNING! Some Dymax fluids can bond skin together in seconds. It can also irritate skin, eyes, and mucous membranes. To minimize the risk of bonded skin or irritation, wear protective gloves and eyewear when working with Dymax fluids and the hand-held spray gun system.

NOTE: Exposing Dymax adhesives to light causes most Dymax adhesives and fluids to begin curing. Hence, to prevent unintentional curing during the loading of bottle reservoirs, have the tank ready to accept the bottle reservoir and complete the loading process quickly after opening the bottle reservoir.

1. Remove the Lid from the Tank by loosening the Lid Hold-Down Knobs.
2. Unscrew the Lid from a 0.26-gal (1-L) or 0.5-gal (2-L) Bottle Reservoir and place the Reservoir into the Tank. Complete this step quickly to prevent initiation and curing of light-sensitive fluids.
3. Install the Tank Lid on the Tank, ensuring the Dip Tube is inserted to the bottom of the Bottle Reservoir. Complete this step quickly to prevent curing of light-sensitive fluids.
4. Tighten the Lid Hold-Down Knobs evenly to ensure uniform sealing.

1-Gallon Upgrade Kit Installation

Existing 1-gallon tanks may be modified by the customer for use with the low-level sensing system using Dymax kit number T18500.

Tools required:

- SAE Wrench Set (9/16", 11/16", 3/4")
- PTFE Tape

1. Remove the 3/8" One-Touch Fitting (connects the Regulator to Tank Lid) with the 3/4" Wrench. Remove the Relief Valve with the 11/16" Wrench.

Figure 8.
Remove Fitting and Relief Valve

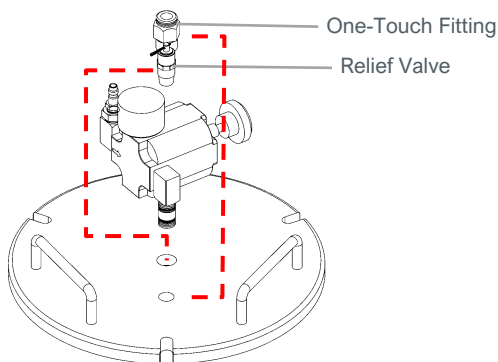

- Remove the Pressure Regulator Assembly (Figure 9). If the Nipple stays on the Lid, use the figures on the left for reference. If the Nipple comes off with the Regulator, use the figures on the right for reference. Kit T18500 comes with an additional Nipple.

Figure 9.
Remove Pressure Regulator

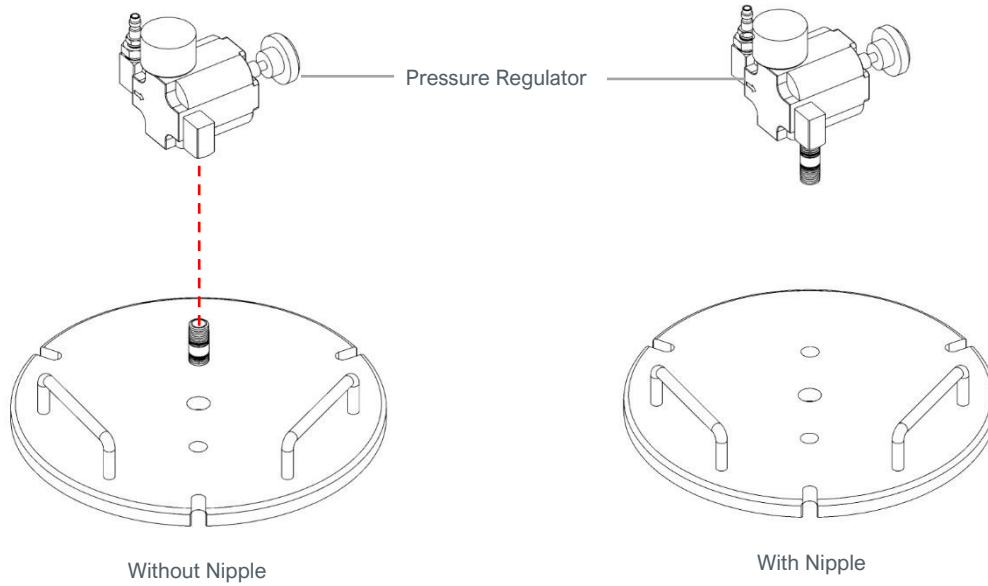

- Remove the Elbow using the 11/16" Wrench. (Figure 10)

Figure 10.
Remove Elbow

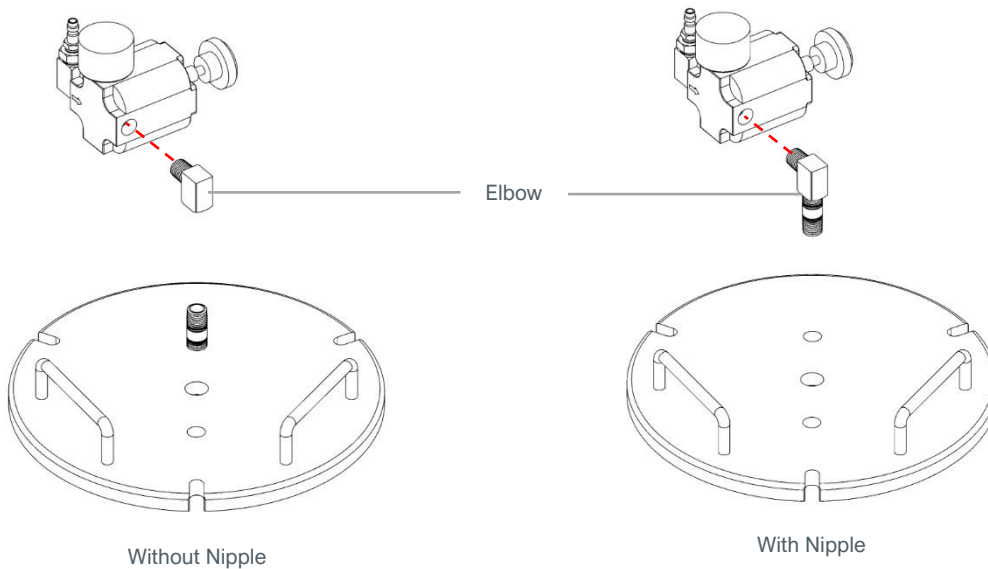

- Remove any old PTFE off the pipe threads and apply PTFE tape to all pipe threads. **Do NOT** apply PTFE tape to the Cord Grip. Feed the Cable through the Nipple, Tee, and Cord Grip as shown in Figure 11. Note that the Connector does NOT fit through the Nipple. Do NOT tighten the Cord Grip.

Figure 11.
Feed Cable through Nipple, Tee, and Cord Grip

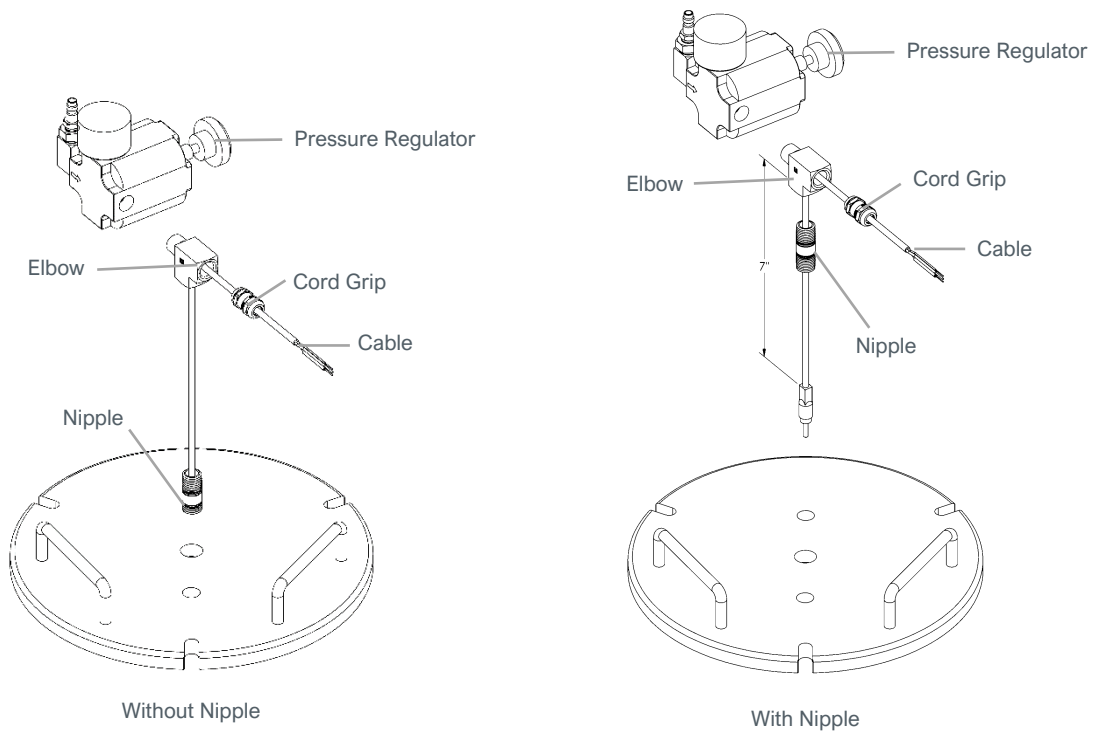

- Assemble the Regulator, Tee, and Cord Grip (and Nipple) together in the orientation shown in Figure 12. Ensure that the pipe threads are tight.

Figure 12.
Assemble Regulator, Tee, Cord Grip, and Nipple

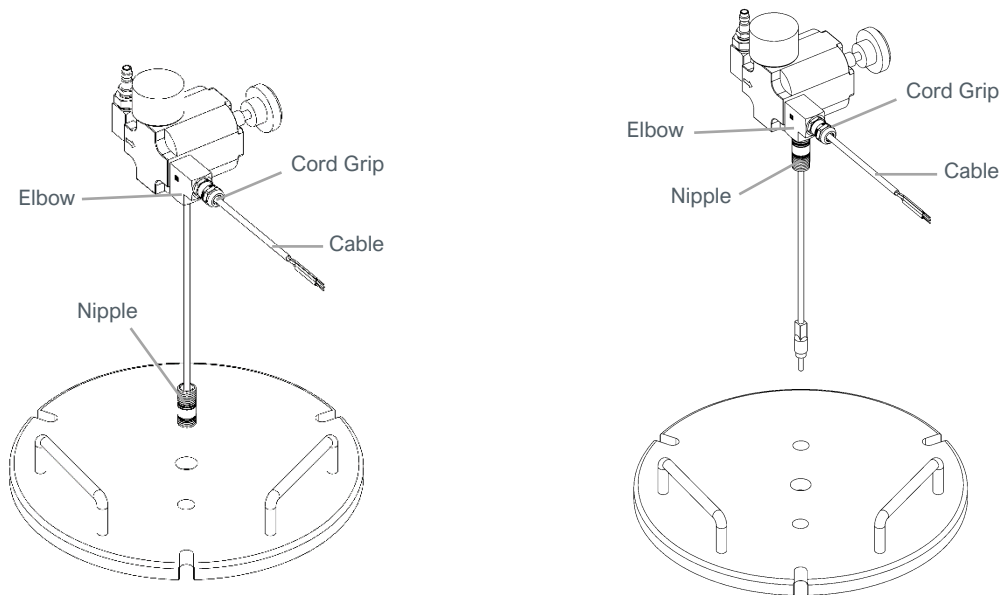

- Install the Regulator onto the Lid (approximate orientation shown below). Remove any old PTFE tape from the 3/8" One-Touch Fitting and the Relief Valve. Apply new PTFE tape and reinstall the One-Touch Fitting and Relief Valve on the Lid (Figure 13). Ensure that the pipe threads are tight.

Figure 13.
Reinstall One-Touch Fitting and Relief Valve on Tank Lid

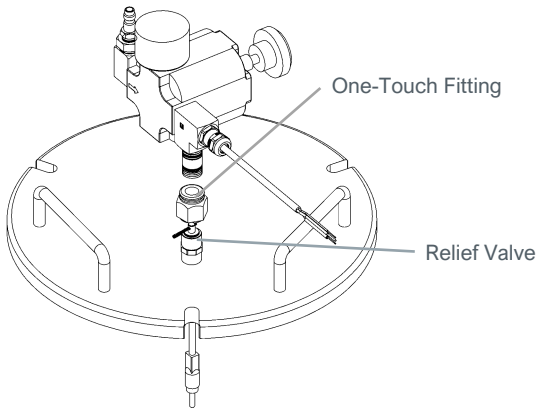

7. Install the Lid on the Tank with the Pressure Plate Sensor. Adjust the cable length inside the Tank so the Lid can be removed and placed next to the Tank without moving the Pressure Plate Sensor. Tighten the Nut on the Cord Grip. **Do NOT** over tighten. Install the Lid again and pressurize the Tank to inspect for air leaks. It is normal for the Pressure Regulator to bleed a small amount of air when pressurized.

SB-100 Controller Setup

Connecting the Sensor to the SB-100 Controller

The SB-100's Connection Terminal is located on the top face of the Controller (Figure 14). It is identified by a green Terminal Block and two Input Jack Terminals.

IMPORTANT! Each terminal serves a specific function, so connection to the proper terminal is critical in the proper operation and function of the level sensing system.

Figure 14.
SB-100 Controller Connection Terminal

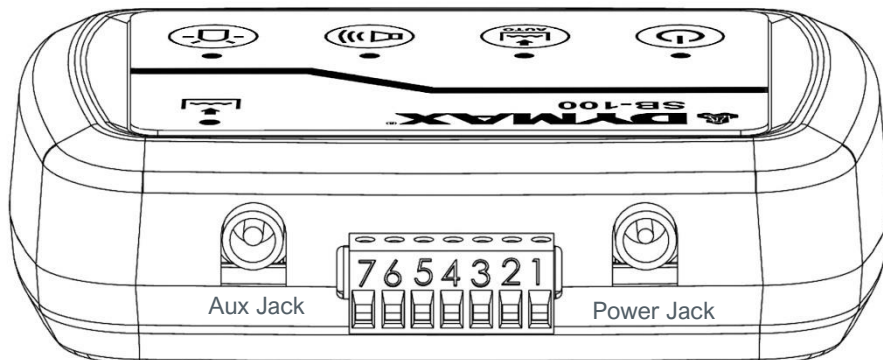

Figure 15.
SB-100 System Wiring Schematic

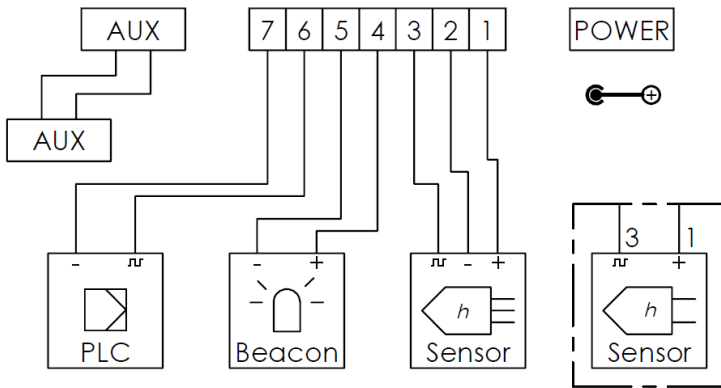

Table 1.
Controller Connections

Type	Terminal (Figure 14)	Description	Capacitive Sensor Connections	Magnetic Sensor Connections
Sensor Inputs If using two wires, connect them to terminals 1 & 3 If using three wires, connect them to terminals 1, 2, & 3	1	+24	Red	Brown
	2	Ground	Black	Blue
	3	Signal (+24V $\overline{\text{-----}}$)	White	Black
Beacon	4	+24V $\overline{\text{-----}}$	Red	Red
	5	Ground	Black	Black
PLC/Logic Terminals	6	Signal (+24V $\overline{\text{-----}}$)	---	---
	7	Ground	---	---
Power Jack	POWER	Input 24V $\overline{\text{-----}}$.75A		
Aux Jack	AUX	Output 24V $\overline{\text{-----}}$.6A		

SB-100 Function Options

The SB-100 Controller is a flexible interface between sensors, indicators, and automation logic/PLC platforms. The SB-100 can be run in “Driver” or “Driven” mode, supporting bench-top to automated manufacturing environments. The following is a review of functionality and connections required across these applications.

Low Level Detection & Warning Only

1. Ensure the power input and appropriate terminal connections are secure.
2. Press the Power Button to turn on the Controller.
3. Select the Audio Buzzer Warning Button and the Beacon Button. The Indicator Lights on the Controller should match Figure 16.
4. Dispense material, ensuring the material level in the cartridge passes by the Capacitive Sensor Eye. For magnetic sensor systems, ensure the magnet passes by the Magnetic Sensor Eye.
5. Evaluate the sensor activation and warning functions.
6. Replace the empty cartridge with a new, full cartridge of material (See Replacing the Cartridge on page 13). The system is ready to dispense.

Figure 16.

Indicator Lights when Power is On with Low-Level Detection & Warning Selected

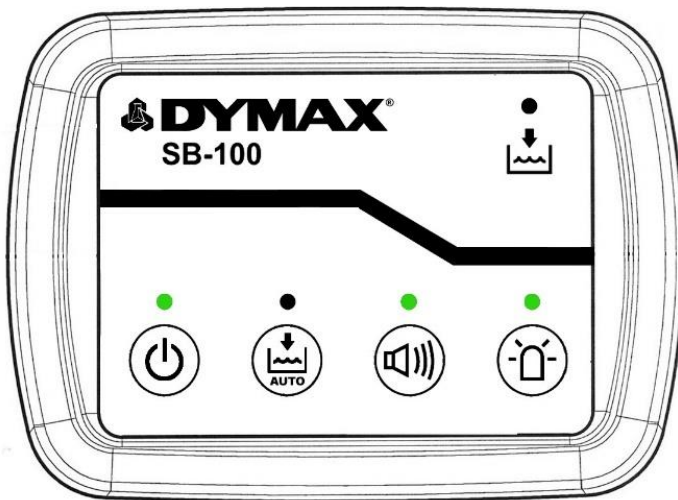

Low-Level Detection with PLC/Automation Logic

1. Ensure power input and appropriate terminal connections are secure.
2. Press the Power Button to turn on the Controller.
3. Select the Audio Buzzer Warning Button and Beacon Button. The Indicator Lights on the Controller should match Figure 16.
4. Connect the SB-100 Terminals to an External PLC or Automation Logic Control.
Note: PLC output is a N.C. (normally closed) design. There will be a steady +24VDC signal only if the sensor is detecting material.
5. Set the PLC/Automation Control to immediate or timed shut-down action based on the signal received from the SB-100.
6. Dispense material, ensuring the material level in the cartridge passes by the Capacitive Sensor Eye. For magnetic sensor systems, ensure the magnet passes by the Magnetic Sensor Eye.

7. Evaluate the sensor activation and warning functions.
8. Replace the empty cartridge with a new, full cartridge of material (See Replacing the Cartridge on page 13). The system is ready to dispense.

Low-Level Detection, Warning, and Auto-Shutdown

1. Ensure power input and appropriate terminal connections are secure.
2. Press the Power Button to turn on the Controller.
3. Select the Audio Buzzer Warning Button, Beacon Button and Auto Shut-Down button. The Indicator Lights on the Controller should match 10.
4. Connect the Aux Jack to an External Controller. Dymax recommends using a DVC-345 Controller, PN T11146.
5. Dispense material, ensuring the material level in the Cartridge passes by the Sensor Eye. For magnetic sensor systems, ensure the magnet passes by the Magnetic Sensor Eye. Once the Sensor is tripped, power to the External Controller will be automatically disconnected, forcing the dispensing line to shut down.
6. Evaluate the sensor activation and warning functions.
7. Replace the empty Cartridge with a new, full Cartridge of material (See Replacing the Cartridge on page 13). Power to External Controller will be automatically restored once the Cartridge is replaced.

Note: The External Controller may need to be restarted after an auto shut-down event.

8. The system is ready to dispense.

Figure 10.

Indicator Lights when Power is On with Low-Level Detection & Warning Selected

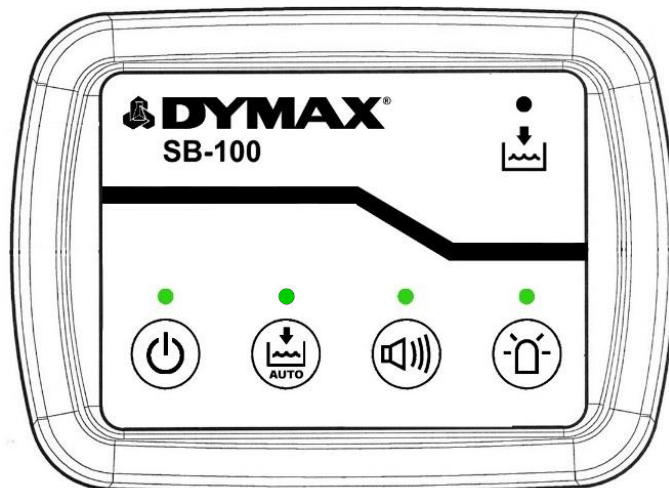

Cleaning & Maintenance

System Cleaning

Switching to a Different Fluid

Since the level sensors do not contact fluid material, the systems will work regardless of material. When switching your system over from dispensing one fluid to dispensing a new fluid, inspect that sensor surfaces are clean and free of obstruction. If you are uncertain about material compatibility or sensor capacity, contact Dymax Application Engineering for assistance.

Periodic Sensor Maintenance

Using a damp cloth, clean the cartridge sensor periodically with benign solvent or Isopropyl Alcohol to ensure contacts are free of debris.

Using a damp cloth, clean the tank pressure plate periodically with benign solvent or Isopropyl Alcohol to ensure the mechanism is clear of debris and maintains free range of motion.

Do not soak or submerge sensors in liquid.

Ensure ALL power is disconnected from SB-100 and sensors before cleaning.

Troubleshooting

Table 2.
Low-Level Sensing Systems with Cartridge Holders

Problem	Possible Cause	Corrective Action
Sensor is not detecting fluid levels	Sensor is not securely in contact with cartridge	Tighten connection between Cartridge Holder, sensor, and cartridge
	Sensor not signaling or random signaling	Check continuity between sensor and controller
	Material remaining on walls of cartridge	Check piston sizing, ensure wiper is fully cleaning material from walls during dispense
	Magnet is not in proper location	Ensure magnet is installed on the top of piston inside fluid cartridge
SB-100 indicators not working	SB-100 function turned off	Press function button to turn on/off indicators
Sensor moving during operation	Sensor bracket loose	Tighten sensor bracket fasteners
Sensor bracket shows hairline/stress cracks	Cartridge Holder air pressure too high	Reduce air pressure (psi)

Table 3.
Low-Level Sensing Systems with Bottle Drop-In Material Tanks

Problem	Possible Cause	Corrective Action
Tank does not maintain pressure	Bent Air Supply Line	Inspect the Air Supply Line. Straighten and remove any kinks in the Air Supply Line
	Damaged Air Regulator	Install a new Air Regulator
	Damaged Cover U-Cup Seal	Replace the damaged U-Cup Seal
	The Cover is not secured	Tighten all knobs on the cover to secure
	Damaged Air Relief Valve	Replace the Air Relief Valve
	The Sensor Wire is pinched	Ensure the Sensor Wire is inside Tank, free and clear of the Cover
SB-100 indicators not working	SB-100 function turned off	Press the Function Button to turn on/off indicators
	SB-100 alarm sounding	Check wiring for crossed terminal connections
Material not flowing	Material viscosity is too high	Increase the system's inlet fluid pressure
	Material Dispense Tube is too long	Shorten the length of material tube
	Material cured/blocked in tube	Clean or replace tubing
Inconsistent level indications	New bottle/container styles being used	Re-calibrate the Plate Sensor to the desired level
	Bottles/Containers are not exact	Ensure the bottles/containers are exactly the same style/weight
	The Pressure Plate's travel is impeded	Check that Sensor components are moving freely and the Material Dip Tube is not interfering with the bottle's bottom surface

Spare Parts and Accessories

Item	Part Number
Low Level Cartridge Holder Systems	
6 oz. Cartridge Holder and Sensor Only	T18404
12 oz. Cartridge Holder and Sensor Only	T17975
20 oz. Cartridge Holder and Sensor Only	T17971
32 oz. Cartridge Holder and Sensor Only	T17973
Replacement Capacitive Sensor with Mounting Hardware	T18086
Replacement Magnetic Sensor with Mounting Hardware	T18713
Tank Systems	
1-Gallon Bottle Drop-In Tank and Sensor	T18481
Sensor and Fittings to Upgrade Existing 1-Gallon Bottle Drop-In Tank	T18500
Controller	
SB-100 Controller, Beacon, and Power Supply	T18499

Specifications

Materials of Construction

Cartridge sensor = Polypropylene, stainless steel

Tank plate sensor = 304 stainless steel

SB-100 = ABS plastic, internal PCB & Polypropylene connectors

Fluid tubing = light-blocking, black, polyethylene, PTFE

Fluid tubing fittings = acetal, stainless steel

Dymax fluid reservoirs (cartridge, bottles, and pails) = polyethylene

Dymax fluid reservoir piston (on cartridge reservoirs only) = polyethylene

Operating Specifications

Recommended clean/dry compressed air supply to main regulator = 80 psi (5.5 bar) – 120 psi (8.3 bar), using air filter regulator below.

Air Filter Regulator with Dump Valve (Recommended)

Pressure gauge installed from factory = 80 psi (5.5 bar); adjust as required, if installed

Main System Air Regulator

Pressure gauge installed from factory = 80 psi (5.5 bar)

Precision Air Regulator for Material

This regulator controls the pressure on the material. Set at 15 psi (1 bar) for materials under 10,000 cP and 30 psi (2.1 bar) for materials over 10,000 cP.

Cartridge Holder and Tank Sizes

Cartridge Holders accept 6 oz. (160 mL), 12 oz. (300 mL), 20 oz. (550 mL) and 32 oz. (900 mL) reservoirs

Bottle reservoir tank holds 0.26-gal (1-L) and 0.5-gal (2-L) and 1gal (3.75-L) bottle reservoirs

Air Precision Regulator Pressure Gauges

Pressure gauge installed from factory = 0 to 60 psi (0 to 4.1 bar)

Alternative gauges supplied = 0 to 30 psi and 0 to 100 psi (0 to 2.1 bar and 0 to 6.9 bar)

Declaration of Conformity



EU Declaration of Conformity

Manufacturer:
Dymax Corporation
318 Industrial Lane
Torrington CT 06790, USA

Product description: Low Level Sensing System
Model name(s): SB-100

This product complies with the following relevant Union Harmonization Legislation:

Applicable EU Directives:

Electromagnetic Compatibility Directive(2014/30/EU)

Low Voltage Directive(2014/35/EU)

RoHS Directive 2011/65/EU (2015/863)

Applicable Harmonized Standards:

EN55011:2016/A1:2017/A11:2020

EN 61000-3-2:2014 Class A

EN 61000-3-3:2013

EN 61326-1:2013

EN 61010-1:2010 (3rd Edition)

EN IEC 63000:2018

Declaration:

This declaration of conformity is issued under the sole responsibility of the manufacturer.

Signed for and on behalf of:

 3/26/2025 Torrington, CT
Name Date Location



Authorized Signatory:

Robert Gallagher
Engineering Manager, Equipment
Dymax Corporation
Torrington CT., USA



www.dymax.com

North America: +1 860.482.1010 | Europe: +49 611.962.7900 | Asia: +65.67522887

© 2021-2022 Dymax Corporation. All rights reserved. All trademarks in this guide, except where noted, are the property of, or used under license by Dymax Corporation, U.S.A.

Please note that most dispensing and curing system applications are unique. Dymax does not warrant the fitness of the product for the intended application. Any warranty applicable to the product, its application and use is strictly limited to that contained in Dymax's standard Conditions of Sale. Dymax recommends that any intended application be evaluated and tested by the user to ensure that desired performance criteria are satisfied. Dymax is willing to assist users in their performance testing and evaluation by offering equipment trial rental and leasing programs to assist in such testing and evaluations. Data sheets are available for valve controllers or pressure pots upon request.



UK Declaration of Conformity

Manufacturer:
Dymax Corporation
318 Industrial Lane
Torrington CT 06790, USA

Product description: Low Level Sensing System
Model name(s): SB-100

This product complies with the following relevant UK Legislation:

Applicable UK Legislation:
Electromagnetic Compatibility Regulations 2016

Applicable Harmonized Standards:
EN55011:2016/A1:2017/A11:2020
EN 61000-3-2:2014 Class A
EN 61000-3-3:2013
EN 61326-1:2013
EN 61010-1:2010(3rd Edition)

Electrical Equipment Safety Regulations 2016

The Restriction of the Use of Certain Hazardous Substances in Electrical And Electronic Equipment Regulations 2012 EN IEC 63000:2018

Declaration:

This declaration of conformity is issued under the sole responsibility of the manufacturer.

Signed for and on behalf of:

 6/26/2025 Torrington, CT USA
Name Date Location



Authorized Signatory:

Robert Gallagher
Engineering Manager, Equipment
Dymax Corporation
Torrington CT., USA



North America +1 860.482.1010 | Europe, +49 511.362.7900 | Asia +65 67522887

© 2021-2022 Dymax Corporation. All rights reserved.

Please note that most dispensing and curing system applications are unique.

Warranty

From date of purchase, Dymax Corporation offers a one-year warranty against defects in material and workmanship on all system components with proof of purchase and purchase date. Unauthorized repair, modification, or improper use of equipment may void your warranty benefits. The use of aftermarket replacement parts not supplied or approved by Dymax Corporation will void any effective warranties and may result in damage to the equipment.

IMPORTANT NOTE: DYMAX CORPORATION RESERVES THE RIGHT TO INVALIDATE ANY WARRANTIES, EXPRESSED OR IMPLIED, DUE TO ANY REPAIRS PERFORMED OR ATTEMPTED ON DYMAX EQUIPMENT WITHOUT WRITTEN AUTHORIZATION FROM DYMAX. THOSE CORRECTIVE ACTIONS LISTED ABOVE ARE LIMITED TO THIS AUTHORIZATION.

Index

- Accessories, 26
- Assembly
 - Bottle drop-In Reservoirs, 13
 - Cartridge Reservoir Systems, 11
- Cartridge Reservoir Replacement, 13
- Cleaning, 24
- Connections
 - SB-100 Controller, 20
- Controller Settings, 21
- Help, 4
- Main Components, 8
- Maintenance, 24
- Parts List, 11
- PLC/Automation Logic Integration, 22
- Product Overview, 7
- Safety, 4, 5
 - Using Safe Operating Pressures, 4
- Settings
 - Sensor Indication Level, 11
- Spare Parts, 26
- Specifications, 27
 - Air Regulator Specifications, 27
 - Materials of Construction, 27
 - Operating Specifications, 27
 - Reservoir Specifications, 27
- Support, 4
- Troubleshooting, 25
- Unpacking, 11
- Utilities, 8
- Warranty, 29



Americas: +1.860.482.1010 | Europe: +49 611.962.7900 | Asia: +65.67522887

© 2014-2025 Dymax Corporation. All rights reserved. All trademarks in this guide, except where noted, are the property of, or used under license by Dymax Corporation, U.S.A.

Please note that most dispensing and curing system applications are unique. Dymax does not warrant the fitness of the product for the intended application. Any warranty applicable to the product, its application and use is strictly limited to that contained in Dymax standard Conditions of Sale published on our website. Dymax recommends that any intended application be evaluated and tested by the user to ensure that desired performance criteria are satisfied. Dymax is willing to assist users in their performance testing and evaluation. Data sheets are available for valve controllers or pressure pots upon request. T17982 MAN070 7/3/2025