

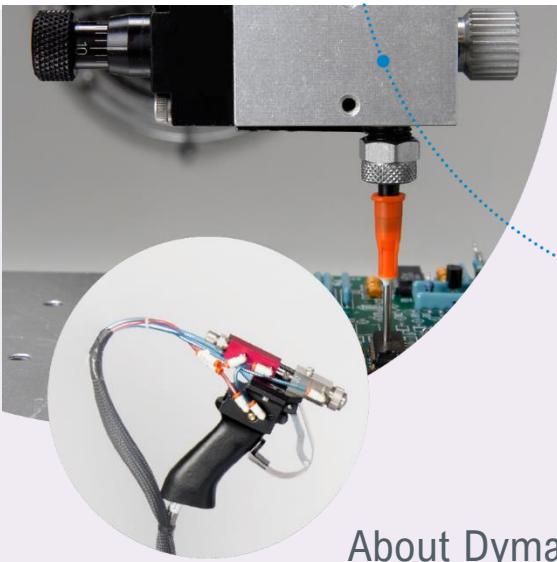

# Model 775 Spool Dispensing Valve

User Guide





## About Dymax

**Light-curable adhesives. Systems for light curing, fluid dispensing, and fluid packaging.**

Dymax manufactures industrial adhesives, light-curable adhesives, epoxy resins, cyanoacrylates, and activator-cured adhesives. We also manufacture a complete line of manual fluid dispensing systems, automatic dispensing systems, and light-curing systems. Light-curing systems include LED light sources, spot, flood, and conveyor systems designed for compatibility and high performance with Dymax adhesives. Dymax adhesives and light-curing systems optimize the speed of automated assembly, allow for 100% in-line inspection, and increase throughput. System designs enable stand-alone configuration or integration into your existing assembly line.

Please note that most dispensing and curing system applications are unique. Dymax does not warrant the fitness of the product for the intended application. Any warranty applicable to the product, its application, and use is strictly limited to that contained in the Dymax standard Conditions of Sale. Dymax recommends that any intended application be evaluated and tested by the user to ensure that desired performance criteria are satisfied. Dymax is willing to assist users in their performance testing and evaluation. Data sheets are available for valve controllers or pressure pots upon request.

# Contents

<b>Introduction</b> .....	<b>3</b>
Where to Get Help.....	4
<b>Safety</b> .....	<b>4</b>
General Safety Considerations .....	5
Specific Safety Considerations.....	5
<b>Product Overview</b> .....	<b>6</b>
Description of the Model 775 Dispensing Valve.....	6
Special Features and Benefits of the Model 775 .....	7
Suck-Back Feature.....	7
<b>Assembly and Setup</b> .....	<b>7</b>
Unpacking and Inspecting Your Shipment.....	7
Parts Included with the Model 775 Dispensing Valve..	8
Mounting.....	8
System Interconnect .....	8
Priming.....	10
Valve Setting Adjustments .....	11
<b>Operating the Dispensing Valve</b> .....	<b>13</b>
<b>Maintenance</b> .....	<b>14</b>
<b>Troubleshooting</b> .....	<b>15</b>
<b>Spare Parts and Accessories</b> .....	<b>16</b>
Special Options .....	16
<b>Specifications</b> .....	<b>19</b>
<b>Warranty</b> .....	<b>21</b>
<b>Index</b> .....	<b>21</b>

# Introduction

This guide describes how to assemble, use, and maintain the Dymax Model 775 dispensing valve safely and efficiently.

## Intended Audience

Dymax prepared this user guide for experienced process engineers, maintenance technicians, and manufacturing personnel. If you are new to pneumatically operated fluid dispensing equipment and do not understand the instructions, contact Dymax Application Engineering to answer your questions before using the equipment.

## Where to Get Help

Dymax Customer Support and Application Engineering teams are available in the United States, Monday through Friday, from 8:00 a.m. to 5:30 p.m. Eastern Standard Time. You can also email Dymax at [info@dymax.com](mailto:info@dymax.com). Contact information for additional Dymax locations can be found on the back cover of this user guide.

Additional resources are available to ensure a trouble-free experience with our products:

- Detailed product information on [Dymax.com](https://www.dymax.com)
- Dymax adhesive Product Data Sheets (PDS) on our website
- Safety Data Sheets (SDS) provided with shipments of Dymax adhesives

# Safety



**WARNING!** *If you use this fluid dispensing equipment without first reading and understanding the information in this guide, personal injury can result from the uncontrolled release of high-pressure gas, injection injury, or exposure to chemicals. To reduce the risk of injury, read and understand this guide before assembling and using Dymax fluid dispensing equipment.*

## General Safety Considerations

All users of Dymax fluid dispensing equipment should read and understand this user guide before assembling and using the equipment.

To learn about the safe handling and use of dispensing fluids, obtain and read the SDS for each fluid before using the fluid. Dymax includes an SDS with each adhesive sold. SDS for Dymax products can also be requested through the Dymax website.

## Specific Safety Considerations

### Using Safe Operating Pressures

Pressurizing the components in the dispensing system beyond the maximum recommended pressure can result in the rupturing of components and serious personal injury. To minimize the risk of rupturing components and injury, do not exceed the maximum operating pressure of the components in your fluid dispensing system (see system specifications on Page 17).

### Preventing Injection Injury

Discharging fluids or compressed air with a dispensing tip against your skin can cause very serious injection injury. To minimize the risk of injection injury, do not place the dispensing tip in contact with your skin.

# Product Overview

## Description of the Model 775 Dispensing Valve

The Model 775 dispensing valve is a pneumatically operated, normally closed spool valve. The 775 provides precise control over both the rate of flow while operating and the amount of suck-back when closing. Control over the amount of suck-back is mandatory to achieve constant string-less cut-off of tacky materials and to eliminate air entrapment. Suck-back control also prevents a droplet from remaining on a dispense nozzle when used with thin materials, which drastically effects accuracy and repeatability. Both controls are conveniently located on the end opposite the material outlet and are lockable to prevent drift or tampering.

The Model 775 dispense valve is ideally suited to automated applications but can also be configured in bench-top systems with a DVC-345 valve controller and material reservoir.

**Figure 1.**  
Model 775 Main Components

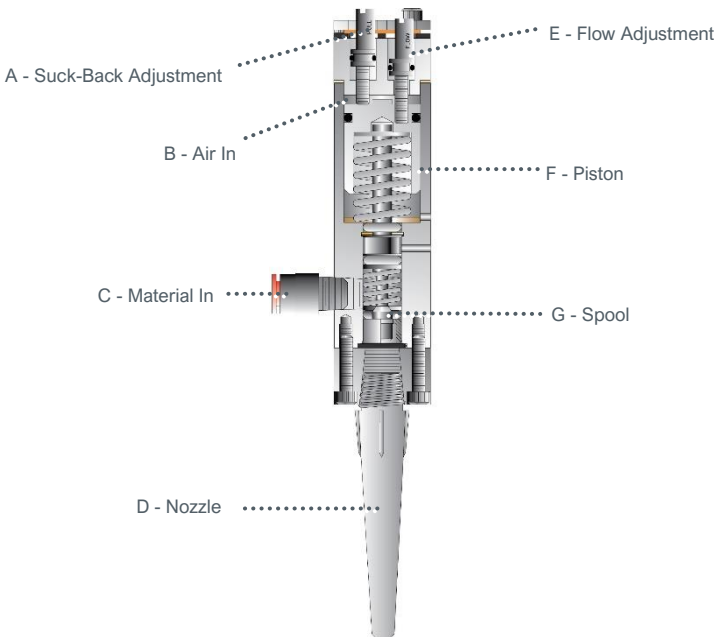

## Special Features and Benefits of the Model 775

Feature	Benefit
Lockable controls	Prevents drifting or tampering
Adjustable suck-back	Clean shutoff of thick, tacky, and/or stringy materials
	Minimizes skinning over of dispense tip

### Suck-Back Feature

The suck-back feature on the 775 valve allows for the clean shutoff of stringy and tacky materials and prevents the formation of a droplet at the end of the dispense nozzle. The suck-back feature also minimizes the "skinning" over of materials that tend to dry out at the end of the nozzle.

## Assembly and Setup

### Unpacking and Inspecting Your Shipment

When your Model 775 dispensing valve arrives, inspect the boxes for damage and notify the shipper of box damage immediately.

Open each box and check for equipment damage. If parts are damaged, notify the shipper and submit a claim for the damaged parts. Contact Dymax so that new parts can be shipped to you immediately.

Check that the parts included in your order match those shown on the Parts Included list. If parts are missing, contact your local Dymax representative or Dymax Customer Support to resolve the problem.

## Parts Included

- Model 775 spool valve
- 4" polyethylene nozzles with 1/16" and 1/8" diameter orifice
- 1/4" MNPT luer lock adapter
- Model 775 user guide

**Figure 2.**  
Model 775 Spool Valve



## Mounting

*Note: If the dispense valve is to be mounted in an area that limits access to the valve, it is recommended that the set-up operation be done prior to mounting. Access to various surfaces of the valve is necessary for periodic adjustment (see Specifications).*

To mount the valve, use the two 3/16" diameter thru holes clearance for 8-32 screws located on the valve's outlet block.

## System Interconnect

Before the valve has been mounted to a suitable support structure, connect the air and material lines to their respective fittings.



**Figure 3.**  
Model 775 Interconnect Diagram

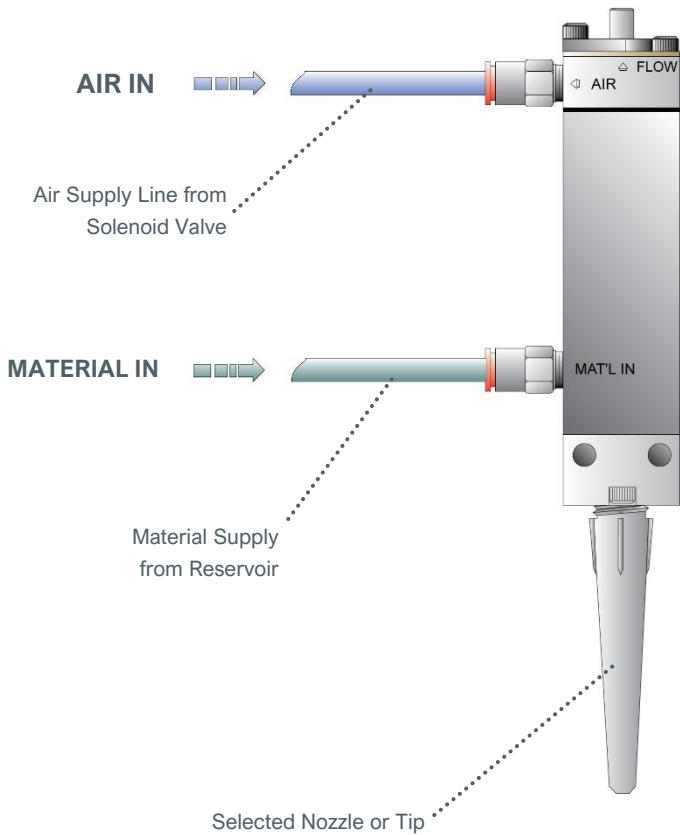

## Air

The valve is operated by a 60-80 psi external air signal provided from the Dymax DVC-345 digital valve controller or a user-supplied 3-way air valve. The airline connection is made through a 1/8 FNPT port marked AIR (see Figure 3 ).

Connect your air supply (60-80 psi) to your 3-way valve, then connect its normally closed outlet to the 775 valve fitting marketed "AIR".

## Fluid

The supply line for the fluid or material being dispensed is connected to a 1/8 FNPT marked MAT'L IN (see Figure 3). The opposite end of the supply line is connected to a pressurized material reservoir or pumping system.

## Priming

*Note: Priming the valve is necessary to prevent air entrapment in the valve, particularly when dispensing viscous materials. Air in the material can also prevent the valve from functioning properly and cause drooling.*

To prime the valve:

1. If installed, remove the dispense valve from the mount.
2. Invert the valve so that the nozzle end is pointing up.
3. Initiate the dispense cycle and maintain it until a constant and steady flow of material can be seen. Once this has been achieved, turn off the dispenser.

## Valve Setting Adjustments

*Note: All Dymax 775 dispense valves are factory set prior to shipment using air. It is still necessary to adjust both flow and suck-back using your material.*

On top of the 775 valve are two slotted adjustment screws. In order to adjust them, you must loosen the two Socket Head Cap Screws that hold the stainless steel Locking Plate on top of the valve.

*Note: Do not loosen the two screws that secure the end cap to the valve body.*

The Flow Adjustment Screw (marked “FLOW”, Figure 1, E), adjusts the flow rate of the dispensed material through the 775 valve. Clockwise rotation decreases the flow while counterclockwise increases the flow.

The Suck-Back Adjustment Screw (marked “SUCK-BACK”, Figure 1, A) adjusts the amount of pull-back at the end of the dispense cycle. Clockwise rotation decreases the amount of pull-back while counterclockwise increases it.

After the adjustments are made, tighten the two socket-head cap screws to lock the adjustment screws.



**WARNING!** *Under no circumstances should either the Flow or Suck-Back Screws be turned counterclockwise until the o-ring seal on their bodies are exposed. Doing so may cause damage to the valve or may present a hazard to personnel!*

**CAUTION!** *If the Suck-Back Adjustment is backed off too far counter-clockwise, in an effort to increase the pull-back, it may pull some air into the system causing the valve to drip or drool.*

*If the Suck-Back Adjustment is turned clockwise too far, the valve will not be able to close.*

## Adjusting Material Flow

1. Position the valve so the nozzle points down.
2. By turning the Flow Adjusting Screw (Figure 1, E) (clockwise to decrease; counterclockwise to increase) and the time allotted for the dispense cycle, you can adjust the flow rate until the desired volume is achieved.

## Adjusting Suck-Back

*Note: Suck-back adjustment is achieved only after the flow adjustment has been made.*

1. After the dispense cycle, inspect the tip of the nozzle for material.
2. If material is present, remove it from the tip with a cloth or paper towel.
3. Cycle the dispense.
4. If material is detected at the tip, turn the Suck-Back Adjustment Screw (Figure 1, A) counterclockwise (approx. 1/4 turn) to increase the amount of pull-back.
5. Initiate the dispense cycle again.
6. Repeat steps 1-5 until there is no material on the tip after each dispense cycle.

*Note: There should be a crisp shut-off of material if the adjustment is made properly. Care must be taken to avoid too much suck-back when adjusting. This can introduce air into the material or valve and effect the dispense volume.*

After the adjustments above have been made, the 775 dispense valve is ready for installation and use.

# Operating the Dispensing Valve

**Figure 4.**  
Model 775 Actuation

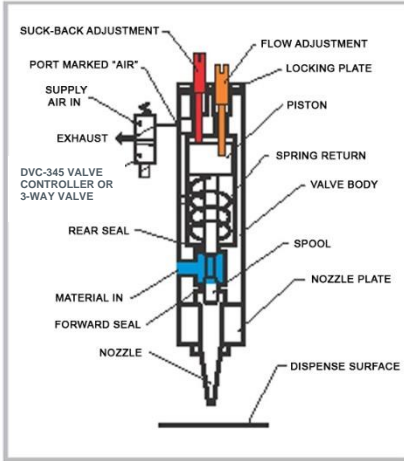

**A - Unactuated**

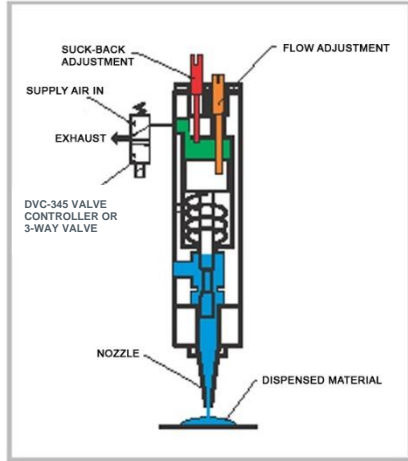

**B - Dispense**

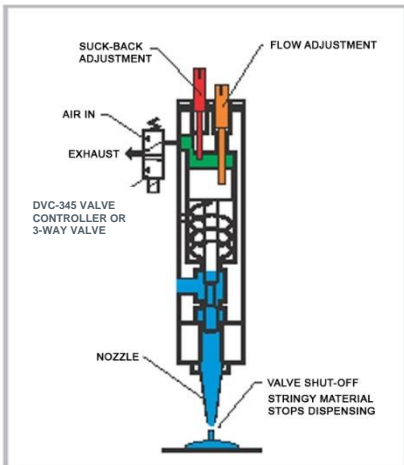

**C - Shut-Off**

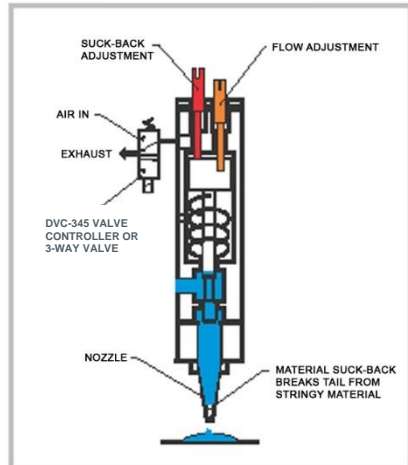

**D - Suck-Back**

Use a Dymax DVC-345 valve controller or a 3-way, normally closed valve to operate the Model 775 (CV of 0.1 or greater).

When the 3-way valve is turned on, the spool moves to its open position (B). The amount the valve opens in conjunction with the amount the material is pressurized determines the amount of flow. The amount the valve opens is set using the flow adjustment screw. When the valve that operates the 775 is turned off, the spool moves to its shut-off position as shown in (C). The spool then continues to travel an amount determined by the suck-back adjustment screw (D). It is this movement that creates the suck-back action. The suck-back can be set in a manner that breaks the “tail” from stringy materials or removes a tiny droplet that would normally remain at the tip of the nozzle with thin materials.

## Maintenance

To clean the Model 775 valve, flush the system with an appropriate solvent. For assistance in selecting a compatible solvent, please contact Dymax Application Engineering.

# Troubleshooting

**Table 1.**  
Troubleshooting Chart for Model 775 Dispensing Valve

Problem	Possible Cause	Corrective Action
<b>Valve does not dispense anything</b>	Fluid pressure is too low	Increase the fluid pressure
	Material is cured in the valve or tip	Disassemble and clean valve
	Flow Adjustment screw is not properly adjusted	Follow Valve Adjustment Procedure
<b>Air bubbles in fluid</b>	Valve not properly purged	Point valve up and cycle until air bubbles are removed
	Problem with material reservoir and fluid delivery system	Diagnose and repair
<b>Material leaks from the valve tip</b>	Suck-back Adjustment screw is not properly adjusted	Follow Valve Adjustment Procedure
	Air bubble trapped in the fluid section of the valve or in the dispense tip	Point the valve up and cycle it until air bubbles are purged out.

# Spare Parts and Accessories

Item	Part Number
<b>Air Regulators</b>	
Air Filter Regulator	T16307
High-Precision Air Regulator	T16629
<b>Controllers</b>	
DVC-345 Digital Valve Controller	T11146
<b>Seal Kits</b>	
Seal Replacement Kit, PTFE	T16566
<b>Stands</b>	
Lab Stand – 24" [60.96 cm]	T15279
Valve Mounting Assembly for Lab Stand	T15450
<b>Rebuild Kits</b>	
Valve Rebuild Kit	T18551

## Special Options

Dymax carries additional accessories for the Model 775 dispensing valve. Please contact Dymax for more information.

- Special nozzles and nozzle arrays
- All stainless and PTFE valve construction
- Integrated multiple valve assemblies
- Adapters to create a hand-held valve dispenser
- End-of-cycle sensing
- “L” style oiler, recommended for abrasive materials



**Figure 5.**  
775 Replacement Parts

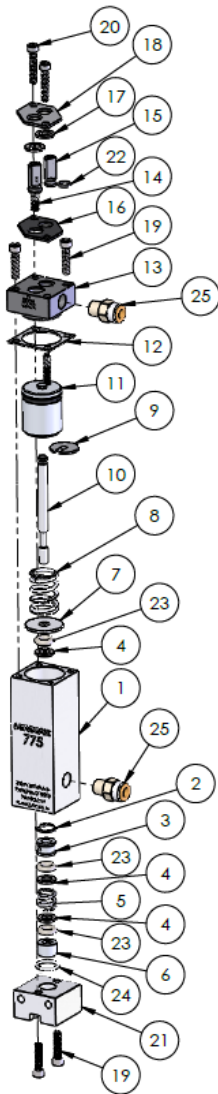

ATTACH END CAP TO VALVE BODY WITH  
SCREWS (19) FIRST. LOOSELY TIGHTEN  
THE LOCKING PLATE WITH SCREWS (20)

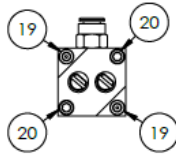

START ASSEMBLY HERE  
INSTALL WITH FLAT SIDE FACING  
THE TOP OF THE VALVE

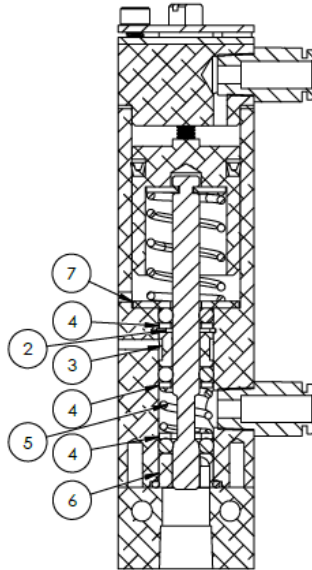

SECTION C-C

SCALE 1 : 1

**Table 2.**  
775 Replacement Parts (Figure 5)

Item	Part Number	Description	Qty
1	<b>T10904</b>	Model 775 Aluminum Valve Body	1
2	<b>T14135</b>	Retaining Ring, 0.5, Snap	1
3*	<b>T11070</b>	Model 775 Rear Bearing, Aluminum	1
4*	<b>T11060</b>	Model 775 Front Retainer Seal	3
5	<b>T14937</b>	Spring, 0.480 OD x 0.067 WR x 0.5 L x K180.7	1
6	<b>T10587</b>	Model 775 Front Spool, Al	1
7	<b>T10905</b>	Model 775 Retainer Seal, Al	1
8	<b>T14938</b>	Spring, 0.72 OD x 0.072 WR x 1.75 L x K22	1
9	<b>T11053</b>	Model 775 Retainer	1
10*	<b>T10587</b>	Model 775 Spool	1
11*	<b>T10345</b>	Model 775 Piston Assembly, Al	1
12	<b>T11067</b>	Model 775 End Cap Gasket	1
13	<b>T10908</b>	Model 775 End Cap, Back, Al	1
14	<b>T10164</b>	Model 775 Adjustment Nut Assembly	1
15	<b>T10906</b>	Model 775 Adjustment Nut	1
16	<b>T10902</b>	Model 775 Gasket, Locking	1
17	<b>T10186</b>	Model 775 Washer, D	2
18	<b>T10941</b>	Model 775 Plate, Locking	1
19	<b>T14212</b>	Socket Head Cap Screw, 8-32 X .75, 18-8	4
20	<b>T14214</b>	Socket Head Cap Screw, 8-32, 0.875	2
21	<b>T10901</b>	Nozzle Block, 1/4 NPT, Al	1
22	<b>T13591</b>	O-Ring, Fluoroelastomer, 009	1
23*	<b>T13581</b>	O-Ring, PTFE, 202	3
24*	<b>T13580</b>	O-Ring, PTFE, 014	1
25	<b>T11674</b>	Fitting, 1/4 OD, 1/8 NPT, Straight	2

\*Parts Included in Model 775 Valve Rebuild Kit **T18551**

# Specifications

Property	Specification
<b>Part Numbers</b>	<b>T15853</b> Model 775 with PTFE seals, 1/4" NPT
	<b>T15855</b> Model 775 with PTFE seals, 1/4 - 28 NPT
	<b>T15859</b> Model 775 with FKM seals, 1/4" NPT
<b>Valve Type</b>	Modified spool with adjustable flow and suck-back controls
<b>Construction Material</b>	Body                      Stainless steel, aluminum, hard-anodized PTFE impregnate, PTFE
	Wetted internal parts      303 and 316 Stainless, PTFE, hard-coated aluminum
	Seals                        FKM (fluoroelastomer) or PTFE
<b>Operating Air Pressure</b>	60-80 psi (4-6 bar)
<b>Maximum Fluid Pressure</b>	PTFE seals                700 psi (48 bar)
	FKM seals                 300 psi (21 bar)
<b>Maximum Operating Temperature</b>	400°F (204°C)
<b>Free Flow Orifice</b>	0.22" [5.59 mm] diameter
<b>Activation</b>	DVC-345 controller or 3-way, normally closed valve (CV of 0.1 or greater)
<b>Dimensions (W x H x D)</b>	1.25" x 5.42" x 1.25" [31.8 mm x 137.7 mm x 31.8 mm]
<b>Weight</b>	0.875 lbs (0.397 kg)
<b>Unit Warranty</b>	1 years from purchase date

\* Flow based on water at 50 psi: Infinitely adjustable from 0 to 7.5 l/min.

**Figure 6.**  
Model 775 Dimensional Drawing

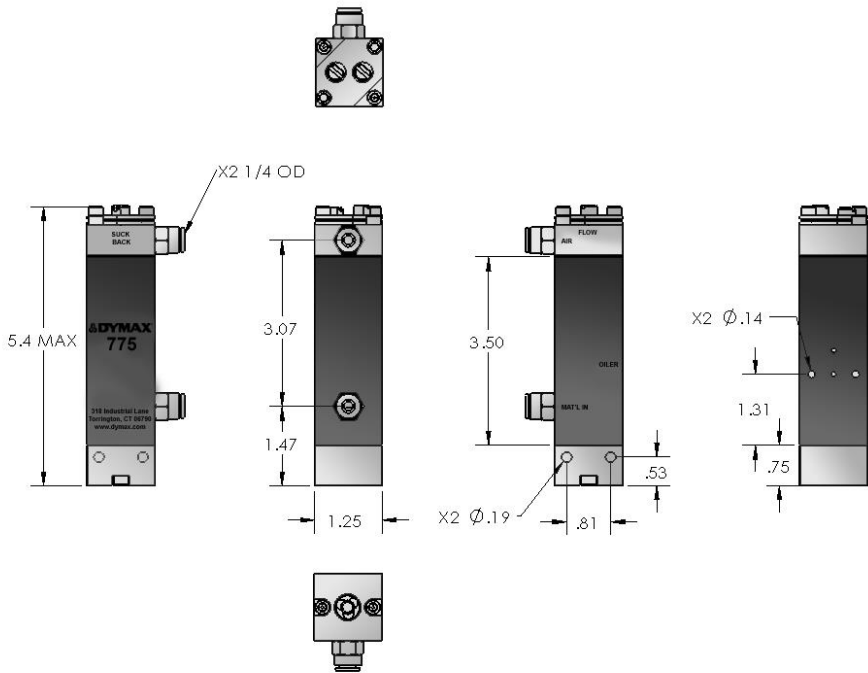

# Warranty

From date of purchase, Dymax Corporation offers a one-year warranty against defects in material and workmanship on all system components with proof of purchase and purchase date. Unauthorized repair, modification, or improper use of equipment may void your warranty benefits. The use of aftermarket replacement parts not supplied or approved by Dymax Corporation, will void any effective warranties and may result in damage to the equipment.

***IMPORTANT NOTE: DYMAX CORPORATION RESERVES THE RIGHT TO INVALIDATE ANY WARRANTIES, EXPRESSED OR IMPLIED, DUE TO ANY REPAIRS PERFORMED OR ATTEMPTED ON DYMAX EQUIPMENT WITHOUT WRITTEN AUTHORIZATION FROM DYMAX. THOSE CORRECTIVE ACTIONS LISTED ABOVE ARE LIMITED TO THIS AUTHORIZATION.***

# Index

- Assembly, 7
- Benefits, 7
- Contact Information, 4
- Description of Model 775, 6
- Dimensions, 18
- Features, 7
- Help, 4
- Maintenance, 13
- Material Flow Adjustment, 11
- Mounting, 8
- Operation, 12
- Optional Equipment, 14
- Parts Included, 7
- Priming, 10
- Product Overview, 6
- Safety, 5
  - Preventing Injection Injury, 5
  - Using Safe Operating Pressures, 5
- Setup, 7
- Spare Parts and Accessories, 14
- Specifications, 17
- Suck Back Adjustment, 11
- Suck Back Feature, 7
- System, 8
- System Interconnect
  - Air, 9
  - Fluid, 9
- Troubleshooting, 13
- Unpacking, 7
- Valve Setting Adjustment, 10
- Warranty, 19





[www.dymax.com](http://www.dymax.com)

North America: +1 860.482.1010 | Europe: +49 611.962.7900 | Asia: +65.67522887

© 2011-2024 Dymax Corporation. All rights reserved. All trademarks in this guide, except where noted, are the property of, or used under license by Dymax Corporation, U.S.A.

**Please note that most dispensing system applications are unique.** Dymax does not warrant the fitness of the product for the intended application. Any warranty applicable to the product, its application and use is strictly limited to that contained in Dymax standard Conditions of Sale published on our website. Dymax recommends that any intended application be evaluated and tested by the user to ensure that desired performance criteria are satisfied. Dymax is willing to assist users in their performance testing and evaluation. Data sheets are available for valve controllers or pressure pots upon request. T17585 MAN032DA 9/04/2024