

yuno  
price list

september 2024

**Laminate Selections**

A three character sku identifies each laminate selection as well as the standard finish offered. Individual components are priced with standard finish on standard laminate.

A variety of Wilsonart® standard laminates with standard finishes is offered on conference and multipurpose tables. Additional colors may be available but are

subject to upcharges and extended lead times. The laminate option is available on components where noted as an option in the material specification code.

All laminate tops will have a 3mm matching edge band.

**PLL Solid Laminate**

Standard Solid

- 671 Designer White, Wilsonart D354-60 Matte Finish
- 672 Frosty White, Wilsonart 1573-60 Matte Finish
- 673 Fashion Grey, Wilsonart D381-60 Matte Finish
- 674 North Sea, Wilsonart D90-60 Matte Finish
- 675 Black, Wilsonart 1595-60 Matte Finish

**20% Upcharge**

- 665 Snow White Velvet, Wilsonart 15501-31 Traceless Laminate
- 666 Charcoal Velvet, Wilsonart 15504-31 Traceless Laminate
- 667 Black Velvet, Wilsonart 15505-31 Traceless Laminate

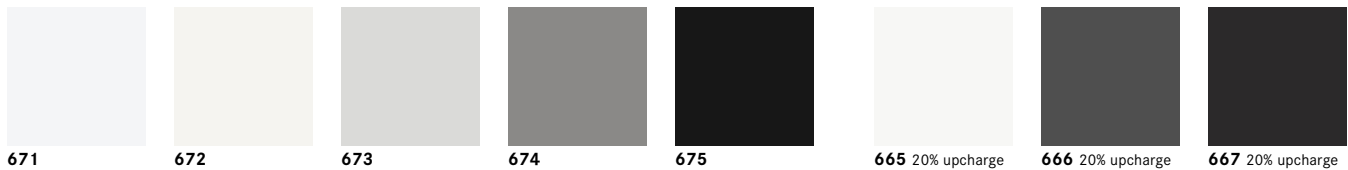

**WGL Woodgrain Laminate**

Standard Woodgrain

- 684 Phantom Pearl, Wilsonart 8211K-28 Gloss Line Finish w/Aeon Scratch Resistant Protection
- 685 Raw Chestnut, Wilsonart 7975K-12 Soft Grain Finish w/Aeon Scratch Resistant Protection
- 686 High Line, Wilsonart 7970K-18 Linearity Finish w/Aeon Scratch Resistant Protection
- 678 New Age Oak, Wilsonart 7938-16 Casual Rustic Finish
- 679 Brazilwood, Wilsonart 7946-38 Matte Finish
- 687 Boardwalk Oak, Wilsonart 7983-38 Fine Velvet Finish
- 683 Portico Teak (Grey), Wilsonart 8210K-28 Gloss Line Finish
- 681 Studio Teak, Wilsonart 7960-16 Casual Rustic Finish
- 680 Walnut Heights, Wilsonart 7965K-12 Soft Grain Finish
- 682 Asian Night, Wilsonart 7949-16 Casual Rustic Finish



**Edge Style Selection**

**FL** Flat Edge

Laminates

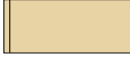

**FL** 3/4" Flat

**Base Selection**

**BK** Black Powder Coat

**CH** Polished Chrome



**Yuno**

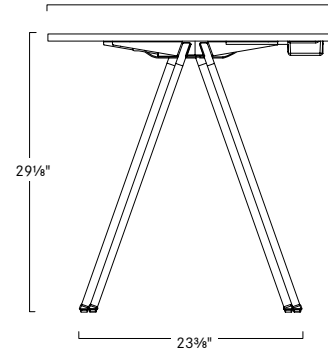

End View Shown With Optional Power Module

**Training Tables Overview**

Designed for use in flexible environments requiring reconfigurations and easy storage. The Yuno is an entry level mobile stacking table for training, work or café environments with options for ganging and grouping in a flexible environment. Available in a number of laminate options with options for basic power and USB charging.

Yuno legs are offered in polished chrome and black powder coat base finishes. The base glide has a small roller integrated so the table can easily be picked up at one end and rolled a short distance for easy arrangement of tables. A silver powder coat transportation cart is available for moving Yuno tables when reconfiguring.

SCS Indoor Advantage™ Gold and LEVEL® 2 certified. See terms and conditions for additional environmental information.

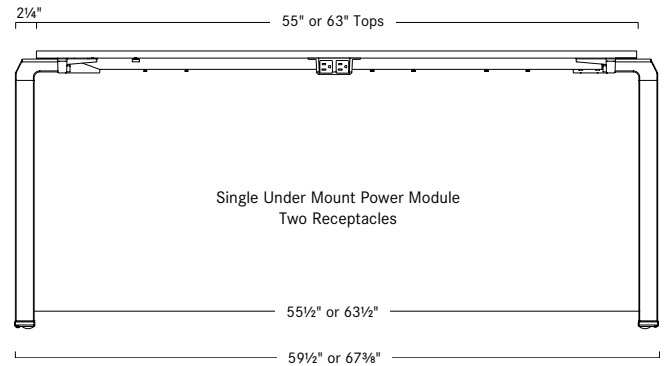

**Single Under Mount Power**

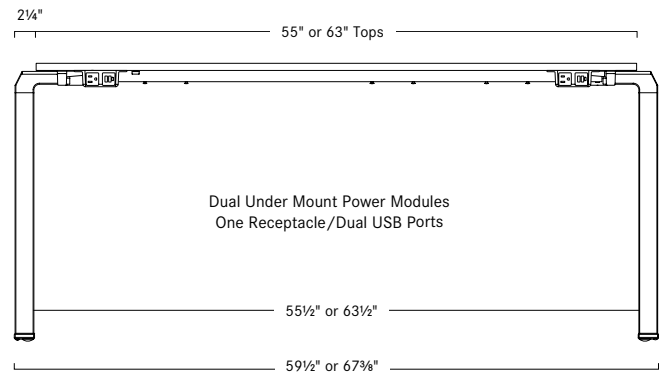

**Dual Under Mount Power**



**Yuno Power Management Overview**

Yuno offers a proprietary under mount power solution allowing quick and easy daisy chaining tables together. For single module configurations, up to (8) tables may be connected on a single power infeed. For dual module configurations, up to (4) tables may be connected on a single power infeed.

## Yuno Configurations

The Yuno table is an entry level mobile stacking table for training, work or café areas with options for ganging and grouping in a flexible environment requiring reconfigurations and simple storage. The worksurface is available in a number of laminate options, and the base is offered in a black powder coat or polished chrome finish.

A new under mount power module for basic power and USB charging is offered. A single under mount module with two receptacles is located in the center of the table; dual under mount modules are located at either end, each with a single receptacle and dual USB ports.

A starter table has the power control unit to power a configuration. Add-on tables connect with the starter table to create configurations. Depending on the application, up to (7) add-on tables may be connected to the starter table. When configurations are "daisy chained", the power infeed location must be specified as all power and wiring are pre-installed. Specify a right or left power infeed for configurations.

### Linear Conference



### Large Closed Conference



### Large Closed Conference with Corner Option



### Small Closed Conference



### Classroom Setting



## Moving Yuno Tables

Yuno impresses with its radically minimalist design by hiding design features such as bumpers, casters and interlocking features, which are not visible at first sight. With this type of design Yuno advances into the training table arena.

Moving Yuno tables is a one person operation. The glides on the foot of the table allow for easy alignment and arrangement of the tables, tilt the table back and let the glides do the work. When placed together the legs interlock and self align the mating table.

**Do not roll tables when they are stacked.**

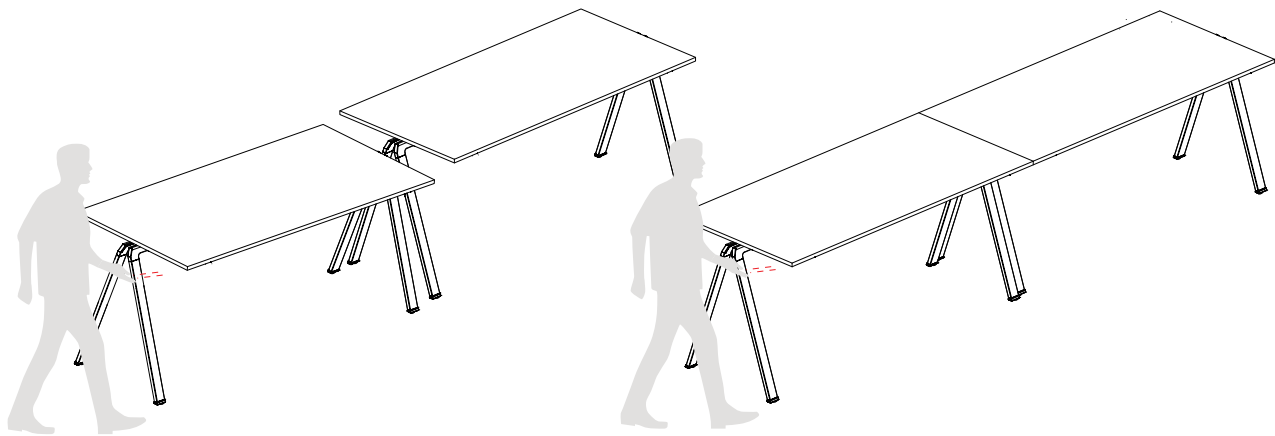

## Bumpers

Bumpers are put in place to protect the legs when nesting together and to protect the table tops when stacking.

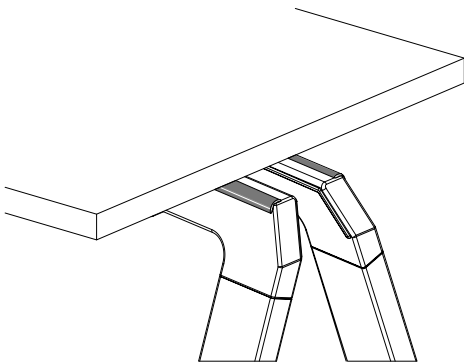

## Nesting

To nest tables, align legs and gently push together until table tops match.

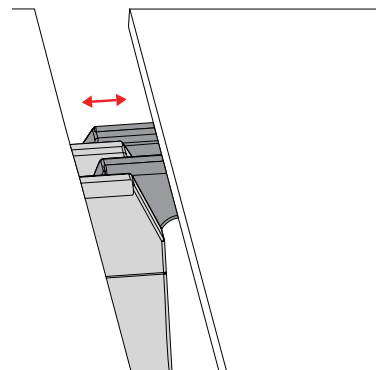

## Glides with Casters

Glides on the base of the legs contain small casters that allow for easy alignment and arrangement of the tables. **These are not intended for transporting the table over distances.**

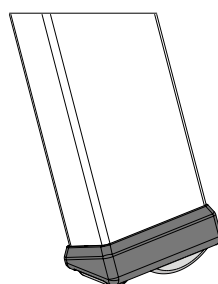

### Stacking and Storing Yuno Tables

A lightweight entry level training table, Yuno is designed to stack without folding. This unique design aids in the practicality of storage by allowing the table to be stacked on the ground with only two people and stacked on a cart by one person.

#### Stacking Yuno Tables on Ground

Stacking the Yuno table on the ground is a **two person** operation. Yuno tables may be stacked a maximum of ten tables high.

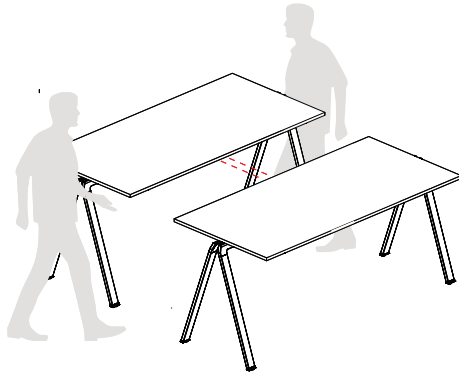

Move the first table near the connecting table.

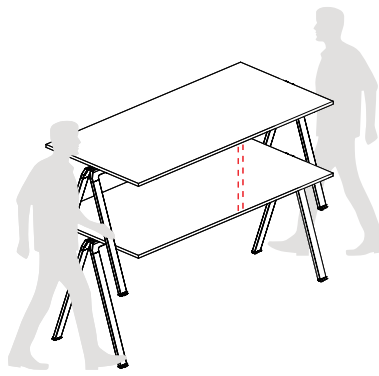

With two people, lift table above the table on the bottom, aligning the legs.

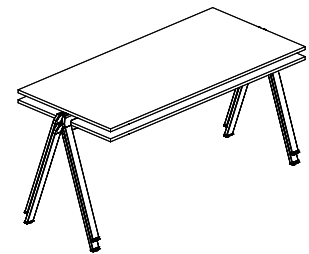

Slowly lower the table and repeat. Tables will stack a maximum of ten high. **Note: After tables are stacked, tables should not be rolled.**

#### Stacking Yuno Tables on Cart

Stacking the Yuno table on the ground is a two person operation while stacking Yuno tables on the transportation cart is a **one person** operation.

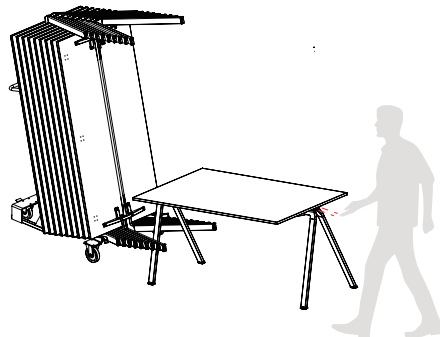

When nesting the Yuno tables on the transportation cart, first set the locking brakes on the cart. Push the table legs tightly up against the cart or receiving table.

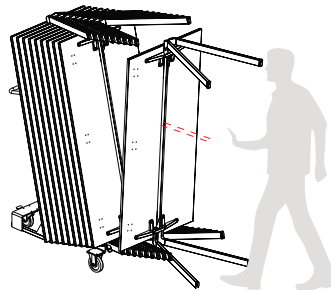

Lift the opposite end of the table to match the receiving table position. Push the table back to ensure the table legs fit snug.

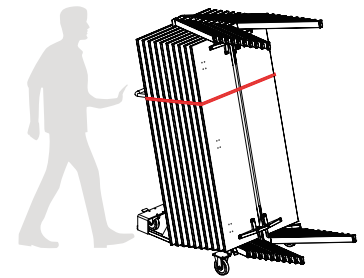

Fasten the tables with a strap and push the cart to storage. Cart will hold a maximum of ten tables.

#### Stacked on Ground

#### Stacked on Cart

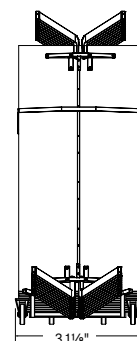
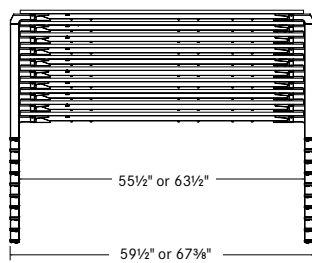
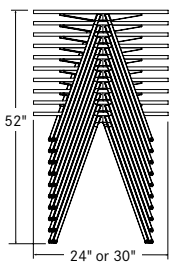

Table Shown - 67½" x 30"

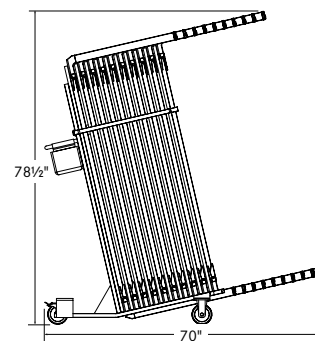
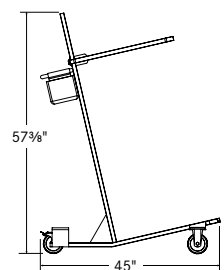
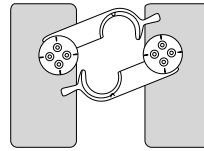

Table Shown - 67½" x 30"



## Ganging Brackets

Yuno tables feature pre-installed ganging brackets making it easier to provide a secure method for connecting tables. Position tables in desired grouping, with table ends touching, then connect the pre-installed ganging brackets. Tables can only be connected at table ends.



## Optional Yuno Accessories

### Modesty Panel

The Yuno modesty panel is constructed using a black elastomeric textile that simply stretches and clips on to each leg with an integral bracket. Each modesty panel has a height of 11".

The modesty panel must be removed for stacking or nesting on the transportation cart. The panel is easily detached and tools are not required for mounting or removing. The panel may be stored in the bag on the back of the cart.

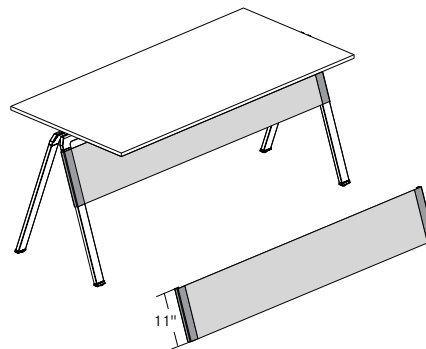

### Transportation Cart

Yuno transportation cart is designed for (1) person to easily load and move up to (10) tables. The cart is equipped with locking 4" casters, a storage bag for modesty panels and a tie down strap to secure the tables for movement.

Using the mobile transportation cart, an individual can break down and set up a room quickly, cutting cost and time.

The transportation cart has a silver powder coat finish.

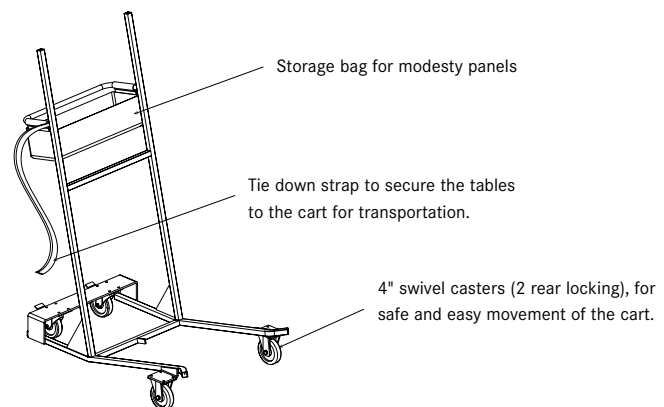



**Single Under Mount Power Module**

Yuno offers a proprietary under mount power solution allowing quick and easy daisy chaining tables together. For single module configurations, up to (8) tables may be connected on a single power infeed.

The single under mount power configuration features a module with (2) 15 amp receptacles mounted in the center of the table.

A starter table must be specified to begin a run of tables. The starter table includes the power module control unit with a 9' grounded plug to connect to the power source. It also provides circuiting allowing add-on tables to be plugged into each other in any order, making set-up and reconfiguration quick and easy.

Single module configurations can only be daisy chained with other single module configurations.

The power assembly and the Yuno tables are UL962 and CSA

**Note: All power and wiring are pre-installed on starter and add-on tables. Specify a right or left power infeed for the starter and add-on tables in a configuration.**

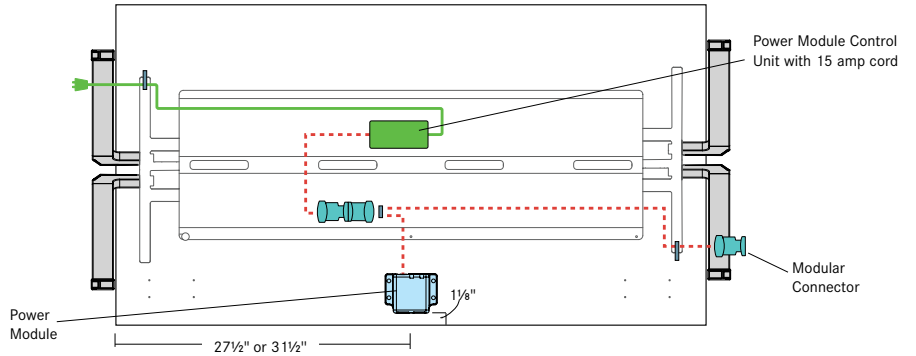

**Power Module**  
Matte Black Finish

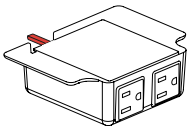

(2) 120 v 60 Hz. 15 amp receptacles

**Modular Connector**  
Matte Black Finish

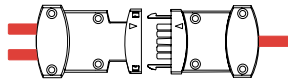

**Power Module Control Unit**  
Control Module with 9' Grounded Plug  
Installed on Starter Tables

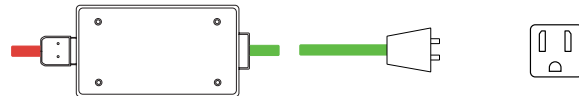

15 amp grounded plug

**Starter Table**

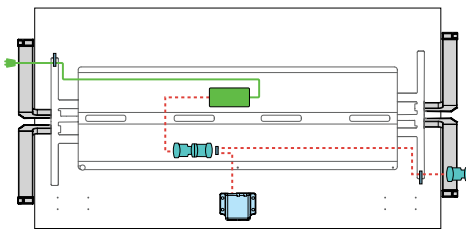

Left Power Infeed

**Add-On Table**

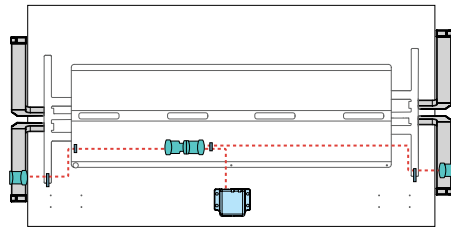

Left Power Add-On

**55" w Tables:** A maximum of (7) add-on tables is possible for a total of (8) daisy chained tables.

**63" w Tables:** A maximum of (3) add-on tables is possible for a total of (4) daisy chained tables.

**Connecting Tables With Single Under Mount Power Modules**

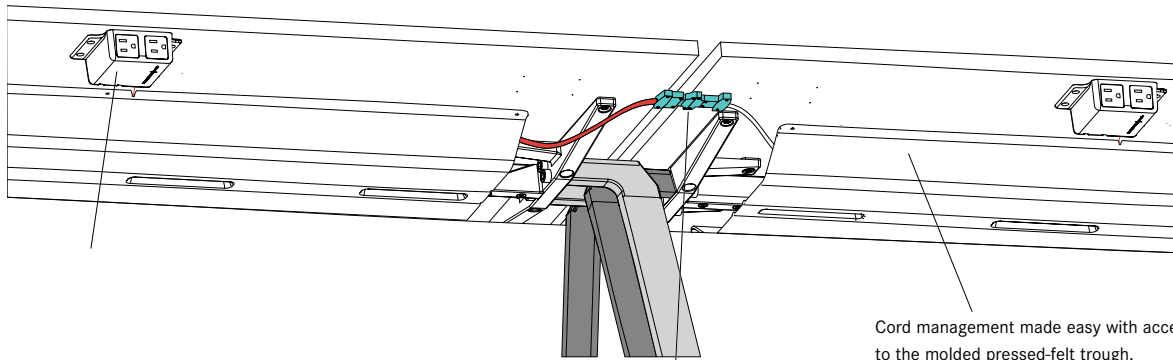

Power module location allows easy access from the front of table.

Align arrows and push whips together to connect power.

Cord management made easy with access to the molded pressed-felt trough.

Note: Molded pressed-felt trough standard with Yuno powered tables.

**Dual Under Mount Power Module**

Yuno offers a proprietary under mount power solution allowing quick and easy daisy chaining tables together. For dual module configurations, up to (4) tables may be connected on a single power infeed.

The dual under mount power configuration uses a (1) 15 amp receptacle, (1) 2 amp USB-A port and (1) 2 amp USB-C port module that comes mounted at the edge of the table.

A starter table must be specified to begin a run of tables. The starter table includes the power module control unit with a 9' grounded plug to connect to the power source. It also provides circuiting allowing add-on tables to be plugged into each other in any order, making set-up and reconfiguration quick and easy.

Dual module configurations can only be daisy chained with other dual module configurations. The power assembly and the Yuno tables are UL962 and CSA 22.2, No. 203.2 approved.

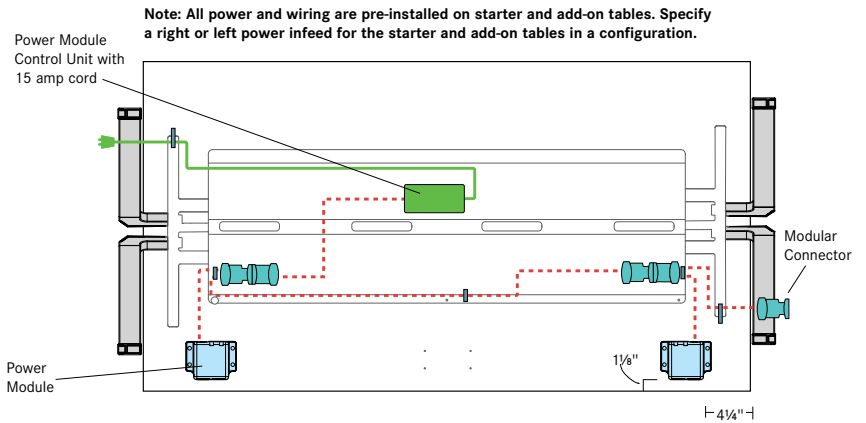

**Power Module**  
Matte Black Finish

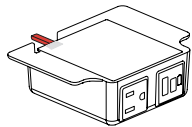

**Modular Connector**  
Matte Black Finish

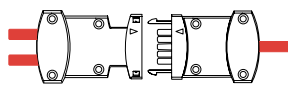

**Power Module Control Unit**  
Control Module with 9' Grounded Plug  
Installed on Starter Tables

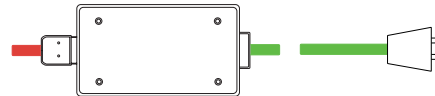

15 amp grounded plug

**power + usb-a + usb-c**

- Updated Information Shown in RED
- (1) 120 v 60 Hz. 15 amp receptacle
- (1) 2 amp USB-A port, 10 watt
- (1) 2 amp USB-C port, 20 watt

**Starter Table**

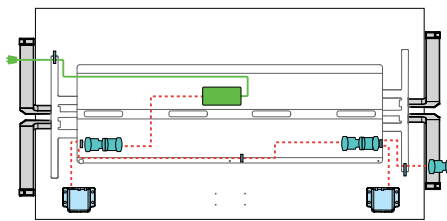

Left Power Infeed

**Add-On Table**

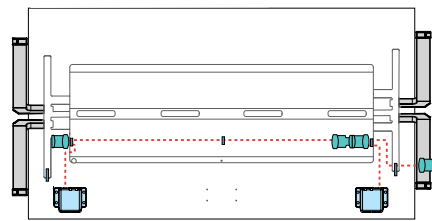

Left Power Add-On

**55" w and 63" w Tables:** A maximum of (3) add-on tables is possible for a total of (4) daisy chained tables.

**Connecting Tables With Dual Under Mount Power Modules**

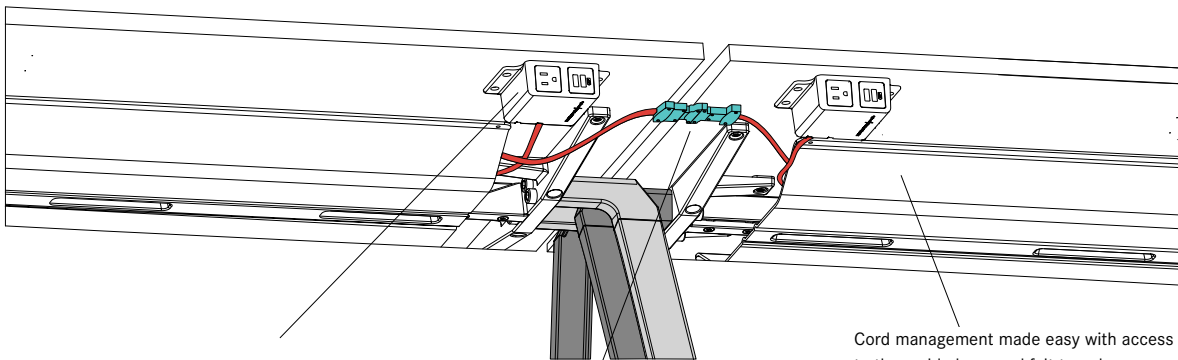

Power module location allows easy access from the front of table.

Align arrows and push whips together to connect power.

Cord management made easy with access to the molded pressed-felt trough.

Note: Molded pressed-felt trough standard with Yuno powered tables.

## Configurations + Power

The configurations below illustrate the number of receptacles in a particular work configuration. The set-ups shown are only some of the many configurations possible. Every situation is unique and should be assessed appropriately.

Please note that power source needs to be located within 6' of each starter table.

- Starter Table
- Add-on Table
- Power Source

### Single Under Mount Power Module

A maximum of (8) 55" w Yuno tables can be daisy chained together when a single under mount power option is specified.

A maximum of (4) 63" w Yuno tables can be daisy chained together when a single under mount power option is specified.

Single module configurations can only be daisy chained with other single module configurations.

### Large Closed Conference

Conference table set up with (8) 63" tables with single under mount power units, totaling (16) receptacles. Requires the customer to order (2) starter tables to power the configuration.

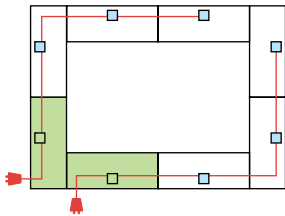

### Classroom Seating

Classroom set up with (24) 55" w tables with single under mount power units, totaling (16) receptacles per row. Requires the customer to order (1) starter table to power a row of (8) tables.

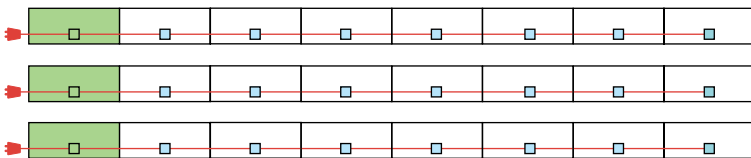

### Small Closed Conference

Conference table set up with (8) 63" w tables with single under mount power units, totaling (16) receptacles. Requires the customer to order (2) starter tables to power the configuration.

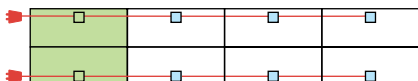

### Dual Under Mount Power Module

A maximum of (4) tables can be daisy chained together when the dual under mount power option is specified.

Dual module configurations can only be daisy chained with other dual module configurations.

### Large Closed Conference

Conference table set up with (8) tables with dual under mount power units, totaling (16) receptacles and (16) dual USB ports. Requires the customer to order (2) starter tables to power the configuration.

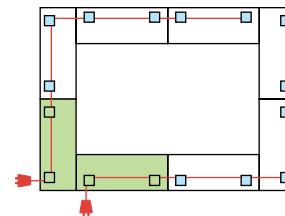

### Classroom Seating

Classroom set up with (18) tables with dual under mount power units, totaling (12) receptacles and (12) dual USB ports per row. Requires the customer to order (2) starter tables to power the row; (6) starter tables for the configuration.

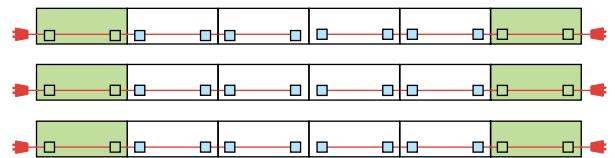

### Small Closed Conference

Conference table set up with (8) tables with dual under mount power units, totaling (16) receptacles and (16) dual USB ports. Requires the customer to order (2) starter tables to power the configuration.





**yuno tables**

standard table without power  
pre-installed ganging brackets  
specify base code BK black powder coat or CH for polished chrome  
shipped KD - assembly required

**corner worksurface**

use pre-installed ganging brackets to connect worksurface to adjoining tops  
when using the corner worksurface in conjunction with surface mount  
daisy chained power, jumpers must be ordered. see page 16.  
specify laminate and finish code

**standard**

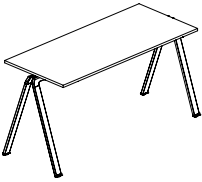

sku	w	d	h	weight	specifications	PLL solid laminate WGL woodgrain laminate	
						BK black base	CH chrome base
TT1	59½	24	29⅞	53 lbs.	55" w top	\$ 2011	\$ 2201
TT2	67⅞	24	29⅞	-	63" w top	2174	2383
TT3	59½	30	29⅞	-	55" w top	2174	2383
TT4	67⅞	30	29⅞	65 lbs.	63" w top	2340	2563

**corner worksurface**

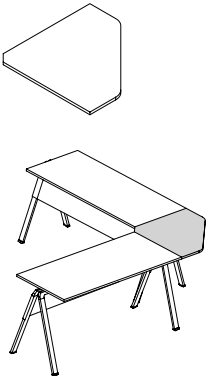

TT5	26¾	26¾	¾		use with 24" d tops	\$ 954	
TT6	32¾	32¾	¾		use with 30" d tops	1037	

**Note:** When using the corner worksurface in conjunction with surface mount daisy chained power, jumpers must be ordered. Jumpers count as a power unit when calculating the number of tables in a powered configuration. See page 16.

specification codes example: YNS-SKU

series	sku
YNS yuno	
Y   N   S   -	

material + finish code example: BK PLL 71

base	top	laminate finish
BK black powder coat CH polished chrome	PLL solid laminate WGL woodgrain laminate	see page 2



**single under mount - daisy chain power**

table includes single under mount power module: double receptacle module, 15 amp grounded plug, 9' cord  
**power pre-installed** - see page 9 for electrical details

pre-installed ganging brackets

specify base code BK black powder coat or CH for polished chrome

starter table: power module control units connects maximum of (8) 55" w or (4) 63" w tables

add-on table: use in configuration with starter table; maximum of (7) 55" w or

(3) 63" w add-on tables with each starter table

specify power infeed location code LP for left hand power infeed; RP for right hand power infeed

shipped KD - assembly required

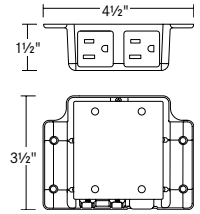

	sku	w	d	h	weight	specifications	PLL solid laminate	
							BK black base	CH chrome base
<b>starter table</b>	AT1	59 1/2	24	29 1/8	53 lbs.	55" w top	\$ 3226	\$ 3547
	AT2	67 3/8	24	29 1/8	-	63" w top	3349	3682

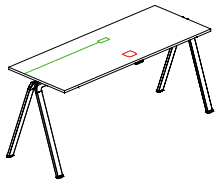

AT3	59 1/2	30	29 1/8	-	55" w top	3349	3682
AT4	67 3/8	30	29 1/8	65 lbs.	63" w top	3471	3818

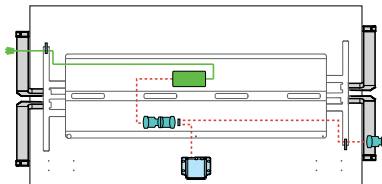

LP Left Power Infeed

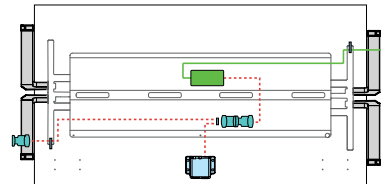

RP Right Power Infeed

<b>add-on table</b>	sku	w	d	h	weight	specifications	2647	2911
BT2	67 3/8	24	29 1/8	-	63" w top, 3 max add-ons per starter table	2772	3048	

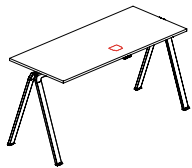

BT3	59 1/2	30	29 1/8	-	55" w top, 7 max add-ons per starter table	2894	3185
BT4	67 3/8	30	29 1/8	65 lbs.	63" w top, 3 max add-ons per starter table	2894	3185

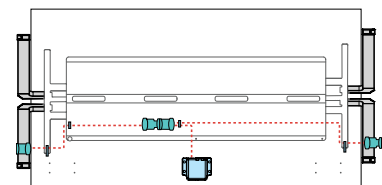

LP Left Power Add-On

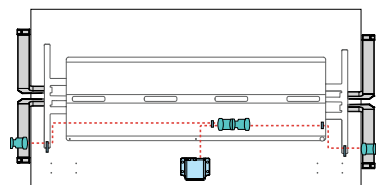

RP Right Power Add-On

specification codes example: YNS-SKU-LP

series	sku	LP RP	left infeed right infeed
YNS yuno		LP	left infeed
		RP	right infeed
Y   N   S   -	-		

material + finish code example: BK PLL 71

base	top	laminat finish
BK black powder coat	PLL solid laminate	see page 2
CH polished chrome	WGL woodgrain laminate	



**dual under mount - daisy chain power**

table includes dual under mount power modules: (1) 15 amp receptacle, (1) 2 amp USB-A port and (1) 2 amp USB-C port; 9' cord grounded plug

**power pre-installed** - see page 10 for electrical details

pre-installed ganging brackets

specify base code BK black powder coat or CH for polished chrome

starter table: power module control units connects maximum of (4) tables

add-on table: use in configuration with starter table; maximum of (3) connecting tables with each starter table

specify power infeed location code LP for left hand power infeed; RP for right hand power infeed

shipped KD - assembly required

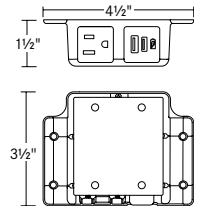

	sku	w	d	h	weight	specifications	PLL solid laminate	
							BK black base	CH chrome base
<b>starter table</b>	CT1	59 1/2	24	29 1/8	53 lbs.	55" w top	\$ 3721	\$ 4000
	CT2	67 3/8	24	29 1/8	-	63" w top	3843	4227

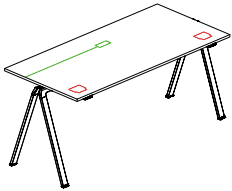

CT3	59 1/2	30	29 1/8	-	55 lbs.	55" w top	3843	4227
CT4	67 3/8	30	29 1/8	65 lbs.	63" w top		3968	4363

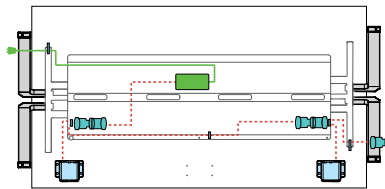

LP Left Power Infeed

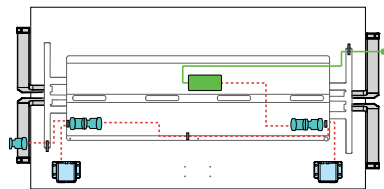

RP Right Power Infeed

<b>add-on table</b>	DT1	59 1/2	24	29 1/8	53 lbs.	55" w top, 3 max add-ons per starter table	3059	3367
	DT2	67 3/8	24	29 1/8	-	63" w top, 3 max add-ons per starter table	3226	3547

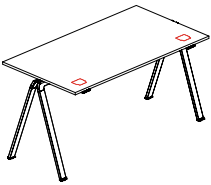

DT3	59 1/2	30	29 1/8	-	55 lbs.	55" w top, 3 max add-ons per starter table	3226	3547
DT4	67 3/8	30	29 1/8	65 lbs.	63" w top, 3 max add-ons per starter table		3391	3729

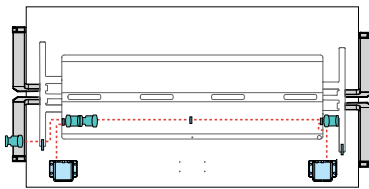

LP Left Power Add-On

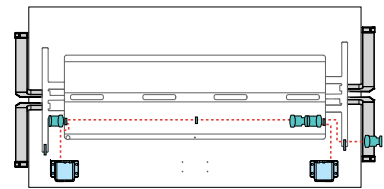







RP Right Power Add-On

specification codes example: YNS-SKU-LP

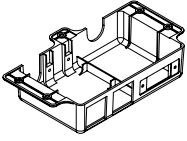
series	sku	
YNS yuno		LP left infeed
		RP right infeed
Y   N   S   -	-	

material + finish code example: BK PLL 71

base	top	laminate finish
BK black powder coat	PLL solid laminate	see page 2
CH polished chrome	WGL woodgrain laminate	

description	sku	w	d	h	specifications	price
 <p><b>under mount replacement housing</b></p> <p>for use with Extron® MAAP installed in the field by end user switch existing housing onsite to this housing to accommodate Extron® MAAP</p>	UPH	7¾	3¾	1½		\$ 201
 <p><b>blank plate</b></p> <p>Extron® MAAP blank plate black powder coat finish single space insert</p>	MP6	2⅛	-	⅝		150
 <p><b>computer/audio/video mini module</b></p> <p>Extron® MAAP HDMI female to HDMI female on 10" pigtail single space insert</p>	MP1	2⅛	-	⅝		385
 <p><b>computer/audio/video mini module</b></p> <p>Extron® MAAP display port female to display port female on 10" pigtail single space insert</p>	MP3	2⅛	-	⅝		385
 <p><b>phone/data mini module</b></p> <p>Extron® MAAP one RJ45 female to punch down leviton CAT6 data single space insert</p>	MP4	2⅛	-	⅝		267
 <p><b>phone/data mini module</b></p> <p>Extron® MAAP one RJ45 female to female barrel single space insert</p>	MP5	2⅛	-	⅝		230

specification codes example: ACS-SKU

series	sku
accessories	
A   C   S   -	

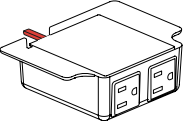
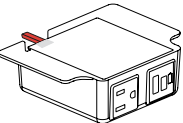
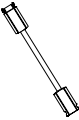
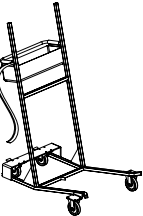
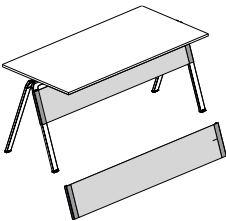
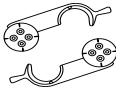
	description	sku	w	d	h	weight	specifications	price
	<b>power module</b> (2) 120 v 60 Hz. 15 amp receptacles 9' cord grounded plug UL 962 listed  Not for use with single module or dual module configuration Can be added to any Yuno standard table as a single power source	UPK	4¾	3½	1½			\$ 316
	<b>power module</b> Updated Information Shown in RED (1) 120 v 60 Hz. 15 amp receptacles (1) 2 amp USB-A port, 10 watt (1) 2 amp USB-C port, 20 watt 9' cord grounded plug UL 962 listed  Not for use with single module or dual module configuration Can be added to any Yuno standard table as a single power source	UPM	4¾	3½	1½			551
	<b>jumper kit</b> Note: When using the corner worksurface in conjunction with surface under mount daisy chained power, jumpers must be ordered. Jumpers count as a power unit when calculating the number of tables in a powered configuration.	JMI	60	1¼	1½	1		154
	<b>transportation cart</b> storage bag, tie down strap (4) casters - two locking accommodates 10 tables shipped KD	TRY	45	18	60			2503
	<b>modesty panel</b> black elastomeric fabric tools not required for mounting or removing	TM1 TM2	55 63	¾ ¾	11 11			268 268
	<b>ganging brackets</b> (4) brackets (1 table) molded nylon	GNG	6½	2	5/8			191

specification codes example: ACS-SKU

series	sku
accessories	
A   C   S   -	



**Prices and Specifications**

Prices and specifications are subject to change without notice. All prices quoted will be FOB our factories. If applicable, sales tax will be based on ship-to destination.

Bernhardt Design reserves the right to make changes in dimensions, construction, price lists, or product literature without prior notice.

All measurements and weights are approximate and subject to change without notice.

**Order Entry**

All orders are subject to final acceptance by Bernhardt Design in Lenoir, NC. Receipt of our acknowledgment indicates acceptance of your order subject to the terms set forth on the acknowledgment.

Bernhardt Design attempts to clarify all purchase orders. However, in the event the price list number and description on the purchase order differ, the price list number will prevail.

**Changes/Cancellation**

All orders in production are considered firm orders and are not subject to changes or cancellation.

**Shipping**

Bernhardt Design will ship in accordance with customer instructions whenever possible. For convenience, Bernhardt Design offers a guaranteed freight program (GFP). Bernhardt Design will exercise our best judgment in selecting a carrier under our GFP. When selecting a carrier, Bernhardt Design will make our best effort to meet requested delivery dates.

Transportation lead-times and delays including equipment problems, weather, general traffic, traffic accidents, customer warehouse space, labor disputes, customer changes, etc., that occur on a carrier will not be the responsibility of Bernhardt Design. Furthermore, Bernhardt Design will not be responsible for additional costs incurred due to aforementioned delays.

For customers who decline our GFP, Bernhardt Design will stage orders for pick up at 1% of the list price, or \$75 minimum.

Customer orders in production will be shipped as scheduled and will not be held. Bernhardt Design reserves the right to make partial shipments on any order, unless notified otherwise by the customer.

High quality cartoning meeting trucking and railroad specifications is standard at no extra charge. Some items may be blanket wrapped for shipment.

**Freight Damage and Claims**

Bernhardt Design is not liable for any damages to products that occur during transit or storage. The carrier assumes all responsibility upon acceptance of product. It is the customer's responsibility to inspect products upon receipt and file any claims with the carrier. No product should be refused. If products are received damaged, a written exception should be made on the bill of lading and an immediate inspection be requested of the carrier.

Concealed damage must be reported to the carrier within 10 business days from date of delivery. Failure to make claims shall constitute acceptance of the products and waiver any claims of defects, errors or shortages.

In the event delivery is made on a Bernhardt Design truck, the products should be carefully inspected for transit damage. If contents are damaged, the driver should be notified to call his dispatcher for immediate disposition.

Concealed damage must be reported within 10 business days from date of delivery and product/packaging held for inspection by a Bernhardt Design representative. Replacements for product damaged in shipment or storage will be manufactured upon receipt of a purchase order.

**Returns**

No merchandise may be returned to Bernhardt Design without written consent in the form of a Return Authorization from our Quality Assurance Department stating why item is being returned and how item will be shipped.

Unauthorized returns will be automatically refused by our receiving department as well as returns not in accordance with Bernhardt Design shipping instructions. Liability for defective merchandise shall be limited to the replacement or repair of that merchandise, and Bernhardt Design shall not be liable for other damages or losses.

**Terms and Credit**

Pricing and terms of sale apply to orders accepted by Bernhardt Design, and no terms, stipulations, or conditions contained in the dealer's submitted purchase orders shall have any force or effect. Bernhardt Design requires a completed and signed credit application from every dealer. Bernhardt Design also requires dealers to provide a Blanket Certificate of Resale/Use containing valid sales tax exemption number(s) for their respective state(s).

If credit has been approved, the standard terms for all Bernhardt Design products are Net 30 from the invoice date. In certain instances, as an additional condition of order acceptance, buyer may be required to provide a deposit at time of order and/or remit the balance before shipment is released. If credit has not been approved, a 100% prepayment, including any freight charges, is required prior to production.

Acceptable forms of payment include a certified check or electronic bank transfer. For information on where to send check/electronic bank information contact our Financial Services Department. If a dealer or company check is submitted, three (3) weeks should be allowed for the clearance of the check. If electronic bank transfer is submitted, one (1) week should be allowed for the clearance of the electronic bank transfer. The order is subject to cancellation if payment in full is not received within three (3) weeks from the acknowledgment date.

The dealer may not make deductions for advertising, promotions, quality problems, freight, or any other reason without prior authorization by Bernhardt Design. Such a deduction could result in the curtailment or suspension of further shipments until the matter is resolved. Delinquency notices are generated and mailed periodically. Service charges of 18% per annum will be added to each past-due transaction. Unpaid service charges

will be accrued and invoiced on a periodic basis. Past-due notices may result in orders being held until the situation is resolved. This credit hold could prevent orders from being placed into production or shipped. Orders not in production that are placed on credit hold for three (3) weeks will be subject to cancellation.

Severe past-due situations may result in the employment of a collection agency or other collection litigation. If any collection activity is necessary regarding a dealer account, the dealer will be responsible for the payment of any and all attorney and collection agency fees.

A slow payment history may result in reducing or eliminating an open line of credit. At the discretion of Bernhardt Design, amounts owed by a dealer to Bernhardt Design arising from any transaction or dealings between the dealer and Bernhardt Design may be offset against any amounts owed to the dealer by Bernhardt Design.

### Warranty

Bernhardt Design will repair or replace, at its discretion, any product or part thereof which fails as the result of defects in material and workmanship, under single shift use and normal care for five years from date of shipment. This warranty shall apply only to the original purchaser.

This warranty does not cover normal wear and tear, misuse or abuse of product, dramatic temperature changes, exposure to unusual conditions or damages incurred by contact with seating products, tables, desks or other surfaces. Natural color changes, variations or movements in lumber or veneer products, exposure to extreme temperature changes and direct sunlight may cause color changes and/or surface damage. These are circumstances beyond the control of Bernhardt Design and are not warranty issues. Repair or replacement of discontinued product will be at the discretion of Bernhardt Design.

This warranty is the customer's exclusive remedy for product defect and does not apply to damage caused by a freight carrier, dealer, installer, user modification, attachments to a product, or any third party. Bernhardt Design has the exclusive right to make the final determination of product misuse or abuse. Except as stated above, Bernhardt Design makes no express or implied warranties as to any product, and in particular, makes no warranty of merchantability or of fitness for any particular purpose. Bernhardt Design shall not be liable for any consequential or incidental damages or for commercial loss arising from any product defect.

### Operational Parts Warranty

Drawer glides, drawer boxes, drawer pulls, and lock mechanisms have a Life-Time Warranty for original purchaser. Power and communication components are warranted for one year.

### Parts Order

Bernhardt Design parts have a \$25 net minimum per order. This does not include freight costs.

### Custom Design

Bernhardt Design may alter products to meet specific needs. Contact your local sales representative when a custom design is needed. Custom designs,

**if approved**, require minimum quantities, additional leadtime and upcharges. A custom job number, available from your Bernhardt Design sales representative, must be submitted with purchase orders.

Orders combining custom design with standard product cannot be scheduled for production until custom items are approved. Custom design orders are not subject to revision or cancellation after acknowledgment.

### Wood Finishes

Bernhardt Design tables are available in finishes that are compatible with credenzas and seating finishes. However, finishes on tables may vary slightly from those on seating due to the natural characteristics of the wood. No absolute match is implied or guaranteed.

### Light Finishes

Bernhardt Design offers lighter finishes on certain veneers and solid woods. When specifying light finishes the natural characteristics of the wood will be visible and color will vary.

Natural characteristics include the natural discolorations of the wood substance and color variations in glued up stock. These natural characteristics are not considered defects by Bernhardt Design, and therefore merchandise will not be replaced.

### Special Finishes

Special finishes, made to customer specifications and subject to factory approval, may be available at a **10% net upcharge with a \$500 net minimum**.

Additional leadtime may be required for special finish items. Special finish orders will not be acknowledged until the special finish sample is approved in writing and received by Bernhardt Design Customer Service. Special finish orders are not subject to revision or cancellation after acknowledgment.

### Installation and Maintenance

All freestanding tables and credenzas are equipped with leveling devices. Local floor conditions vary, and it is always necessary to properly adjust leveling devices. Proper leveling is essential to the alignment and function of doors and drawers.

Improperly leveled units result in misaligned doors and drawers and may impair locking mechanisms or other functional hardware.

After the initial installation of credenzas, it may be necessary to readjust and align the units to compensate for settling. This should be expected as a matter of routine maintenance and follow-up to assure proper case function.

Proper installation of Bernhardt Design tables and credenzas is the responsibility of the dealer. Improperly installed units can result in permanent damage to case components. Damage due to improperly installed furniture not covered under product warranty.

Orders combining custom design with standard product cannot be scheduled for production until custom items are approved. Custom design orders are not subject to revision or cancellation after acknowledgment.

**Care and Cleaning**

Finished wood surfaces should be cleaned with a soft damp cloth, wiping in the direction of the grain. Furniture should be buffed dry immediately with a soft cloth.

**Design and Patent Rights**

All of the products shown in Bernhardt Design catalogs and described in Bernhardt Design price lists are, and remain, the property of Bernhardt Design, with the sole right reserved to manufacture and to distribute.

Some of the product designs shown are patented in the United States and will remain the property of Bernhardt Design. Any reproduction of the products constitutes an infringement of patented copyright laws and will be subject to prosecution.

**Environmental**

Some tables and credenzas are LEVEL® for ANSI/BIFMA e3-2019 – Furniture Sustainability Standard and SCS Indoor Advantage™ Gold certified. Visit the product page at [bernhardtdesign.com](http://bernhardtdesign.com) for certifications.

**Preferred Carrier Guaranteed Freight Rates**

Freight charges will be applied to orders as a separate line item based on the zones listed. Rates are based on zones with a minimum for each zone. All zones are located within the Continental United States.

The freight amount is calculated on the total merchandise list COM price. Additional freight fuel surcharges may apply. Rates are based on deliveries made Monday through Friday, 8 am until 5 pm.

All orders are shipped by Bernhardt Design company trucks or preferred carriers specified by Bernhardt Design. **If a purchase order does not specify that the product must ship complete, Bernhardt Design reserves the right to select the most effective shipping method necessary, including split shipments.** Dealer warehouse information, including phone number and contact name, must be specified on the purchase order.

Zone	Percent	Minimum
Zone 1	3%	\$150
Zone 2	4%	\$150
Zone 3	5%	\$150
Zone 4	5.5%	\$150
Zone 5	6%	\$150

Percent bases on List Price.

Direct site deliveries may be requested with an additional freight cost. Requests for direct site deliveries must be made 2 weeks prior to the scheduled ship week and meet the following criteria:

- Minimum of half truckload
- Delivery site accessible by a 53' trailer
- Complete delivery site address with contact name and on-site phone number
- Labor available for unloading

Deliveries that do not meet the criteria must be directed to a receiver warehouse. If a receiver warehouse is not available, the dealer may make arrangements with their own 3rd party carrier. If a 3rd party carrier is elected, a contact name, phone number and e-mail address is required.

Bernhardt Design has a no touch freight policy. Drivers are not allowed to unload freight.

Weekend direct site deliveries will incur a \$500 per trailer weekend delivery fee. Weekend is defined as between 5 pm Friday and 8 am Monday.

Customers who decline GFP should refer to the shipping section of the Terms and Conditions page.

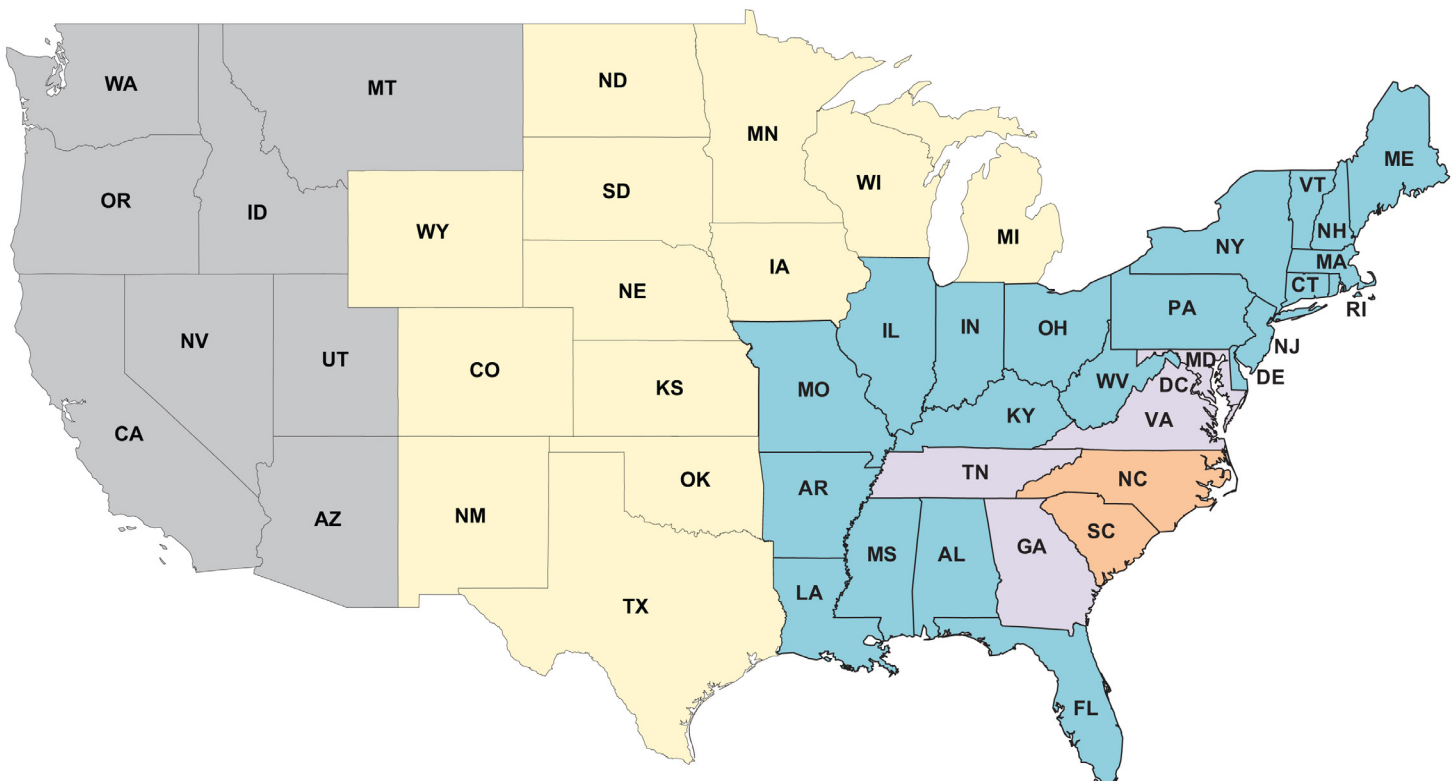

**Preferred Carrier Guaranteed Freight Rates - Canada**

Freight charges will be applied to orders as a separate line item based on the zones listed. Rates are based on zones with a minimum for each zone.

The freight amount is calculated on the total merchandise list COM price. Additional freight fuel surcharges may apply. Rates are based on deliveries made Monday through Friday, 8 am until 5 pm.

All orders are shipped by Bernhardt Design company trucks or preferred carriers specified by Bernhardt Design. If a purchase order does not specify that the product must ship complete, Bernhardt Design reserves the right to select the most effective shipping method necessary, including split shipments. Dealer warehouse information, including phone number and contact name, must be specified on the purchase order.

Direct site deliveries may be requested with an additional freight cost. Requests for direct site deliveries must be made 2 weeks prior to the scheduled ship week and meet the following criteria:

- Minimum of half truckload
- Delivery site accessible by a 53' trailer
- Complete delivery site address with contact name and on-site phone number
- Labor available for unloading

Deliveries that do not meet the criteria must be directed to a receiver warehouse. If a receiver warehouse is not available, the dealer may make arrangements with their own 3rd party carrier. If a 3rd party carrier is elected, a contact name, phone number and e-mail address is required.

Bernhardt Design has a no touch freight policy. Drivers are not allowed to unload freight.

Weekend direct site deliveries will incur a \$500 per trailer weekend delivery fee. Weekend is defined as between 5 pm Friday and 8 am Monday.

Customers who decline GFP should refer to the shipping section of the Terms and Conditions page.

Zone	Minimums	Freight	Avg. Bus. Days
Zone 1	\$200	5%	10-15
Zone 2	\$200	9%	10-15
Zone 3	\$200	8%	10-15
Zone 4	\$200	11%	10-15
Zone 5	Quote	Quote	

The attached rates are strictly freight and do not include brokerage fees.

