

# larkin table price list

january 2025



collection overview		<b>power</b>	21
laminate selections	3	<b>larkin</b>	
veneer selections	4	grommet kit overview	22
base + powder coat selections	5	power	23
collection overview	6	power grommet kits	24-25
tops	7	power with pass thru grommet	26
bases	8	power with pass thru grommet kits	27-28
power overview	9	power with light grommet	29
larkin power overview	10	power with light grommet kits	30-31
wire management	11	light	32
rectangular tops		light grommet kits	33-34
4 leg assembly	12-14	power with light grommet kits plus light	35
6 leg assembly	15-19	<b>under mount</b>	
8 leg assembly	20	power overview	36
		grommet placement kits	37
		grommet kits	38-39
		extron® AAP modules	40
		<b>mediatrac1™</b>	
		power overview	41
		4-trac power system	42
		grommet placement kits	43
		grommet kits	44-47
		wire management	48-49
		extron® AAP modules	50-51
		terms and conditions	52-54
		guaranteed freight	55
		guaranteed freight - canada	56

**Laminate Selections**

A three character sku identifies each laminate selection as well as the standard finish offered. Individual components are priced with standard finish on standard laminate.

subject to upcharges and extended lead times. The laminate option is available on components where noted as an option in the material specification code.

All laminate tops will have a 3mm matching edge band.

A variety of Wilsonart® standard laminates with standard finishes is offered on conference and multipurpose tables. Additional colors may be available but are

**PLL Solid Laminate**

Standard Solid

- 671 Designer White, Wilsonart D354-60 Matte Finish
- 672 Frosty White, Wilsonart 1573-60 Matte Finish
- 673 Fashion Grey, Wilsonart D381-60 Matte Finish
- 674 North Sea, Wilsonart D90-60 Matte Finish
- 675 Black, Wilsonart 1595-60 Matte Finish

**Traceless Laminates - 30% Upcharge**

- 665 Snow White Velvet, Wilsonart 15501-31 Traceless Laminate
- 666 Charcoal Velvet, Wilsonart 15504-31 Traceless Laminate
- 667 Black Velvet, Wilsonart 15505-31 Traceless Laminate

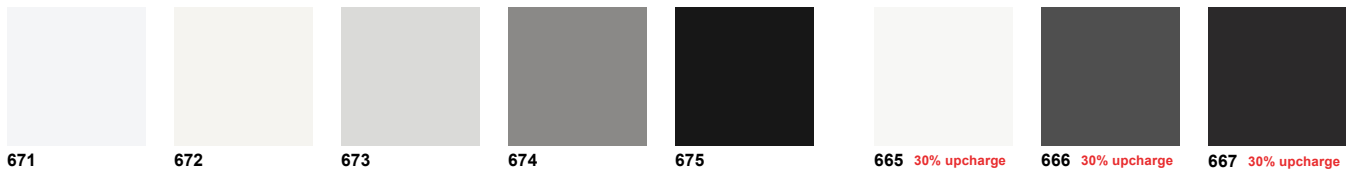

**WGL Woodgrain Laminate**

Standard Woodgrain

- 684 Phantom Pearl, Wilsonart 8211K-28 Gloss Line Finish w/Aeon Scratch Resistant Protection
- 685 Raw Chestnut, Wilsonart 7975K-12 Soft Grain Finish w/Aeon Scratch Resistant Protection
- 686 High Line, Wilsonart 7970K-18 Linearity Finish w/Aeon Scratch Resistant Protection
- 678 New Age Oak, Wilsonart 7938-16 Casual Rustic Finish
- 679 Brazilwood, Wilsonart 7946-38 Matte Finish
- 687 Boardwalk Oak, Wilsonart 7983-38 Fine Velvet Finish
- 683 Portico Teak (Grey), Wilsonart 8210K-28 Gloss Line Finish
- 681 Studio Teak, Wilsonart 7960-16 Casual Rustic Finish
- 680 Walnut Heights, Wilsonart 7965K-12 Soft Grain Finish
- 682 Asian Night, Wilsonart 7949-16 Casual Rustic Finish



**Veneer Selections**

A three character sku identifies each species as well as the standard finish offered. Individual components are priced with standard finish. Special finishes on veneers made to customer specifications are subject to factory approval and a 10% net upcharge with a \$500 net minimum.

Transparent stains and sealers are applied in multiple steps to enhance the beauty of the natural wood. A durable, baked-on, top-coat of conversion varnish

or UV topcoat is applied to protect the product. It is recommended that felt, cork or fabric backed desk pads and accessories are used on worksurfaces to minimize wear.

When specifying light finishes the natural characteristics of the wood will be visible and color will vary. Paint finishes are available as custom orders. See terms and conditions for additional finish information.

**OAK** Oak  
Rift Cut

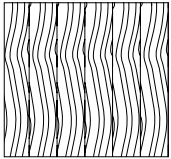

Standard Finish

- \*871 870 839
- 837 860 861
- 865 836 866
- 872 805 845

**WLT** Walnut  
Flat Cut

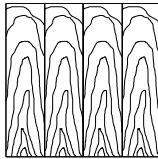

Standard Finish

- 872 861
- \*870 823
- 860 866
- 839

*\*NOTE: Both solid wood and veneers are used in the design of the Larkin tables. This mixing of materials will show a tone/color difference between the parts when natural finishes are specified. Slight shading and color differences may be noticed between the two materials.*

**OAK** Select Finishes

- M73 M72 M75
- M74 M76 M77
- M71

**OAK** Oak



- \*871 837 865 872 870 860 836 805



- 839 861 866 845

**OAK** Select Finishes

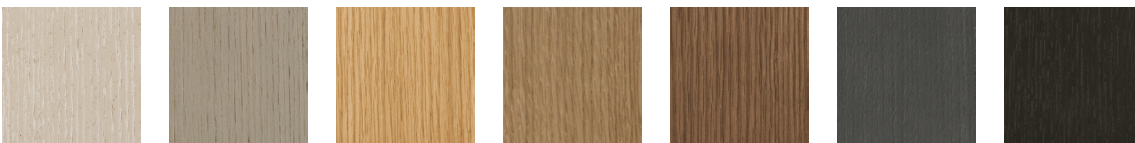

- M73 Whitewash M74 Fawn M71 Blonde M72 Toast M76 Caramel M75 Smoke M77 Coffee

**WLT** Walnut

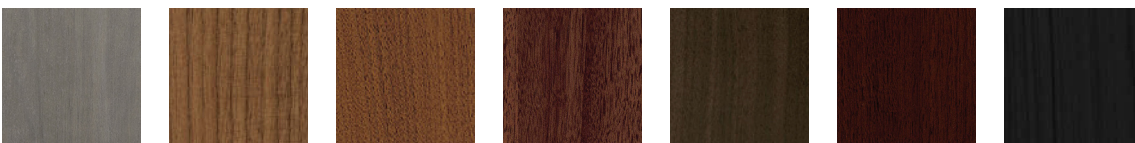

- 872 \*870 860 839 861 823 866

## Base Standard Finishes



**PA** Polished Aluminum

## Powder Coat Selections

A two character sku identifies each powder coat finish offered. Individual skus are priced with standard metal finish. Non-standard finishes may incur an additional charge.

### Powder Coat Finishes

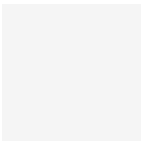

**WH** Satin White



**AL** Matte Aluminum

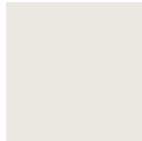

**EC** Ecru

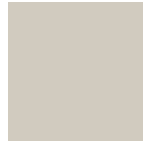

**LA** Latte



**GR** Graphite

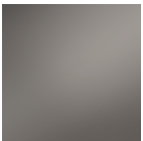

**BZ** Bronze



**SG** Sage



**IG** Iron Grey



**RD** Black Red



**BK** Matte Black

### Optional Powder Coat Colors - RAL

- Lead Time - Three weeks additional lead-time after color approval
- Net Up-charge - \$1000 for colors shown in Bernhardt Design RAL Powder Coat Selector
- Minimum Order Quantity - None
- Approval Sample Cost - None
- Combining Products - One up-charge is applicable for multiple products on a single purchase order when they are in the same color

Larkin Table Collection



The Larkin meeting table offers a design that works beautifully within today's casual work environments. The table features a reverse beveled edge top, solid wood base, polished or power coat aluminum components and new innovative surface mount power options. The most unique offering is a new integrated light that can be used within a power module or alone within the work surface. Blending all these options together, the Larkin meeting table meets the needs of today's flexible work environment.



**Conference Height Table**  
4 Leg Assembly - Ranging from 36" to 60" wide by 60" to 120" long



**Conference Height Table**  
Shown with coordinating Larkin Credenza



**Conference Height Table**  
6 Leg Assembly - Ranging from 36" to 60" wide by 126" to 222" long



**Conference Height Table**  
8 Leg Assembly - Ranging from 36" to 60" wide by 228" to 240" long

**Larkin Tops**



Larkin tops are specifically constructed to accommodate the Larkin bases. Bases and tops are sold as a complete assembly.

Rectangular tops are available in 36" - 60" widths and 60" - 240" lengths. Tops 126"- 222" will have 6 legs, tops 228"- 240" will have 8 legs. Larkin table height is 29½".

Larkin tables are SCS Indoor Advantage™ Gold certified and LEVEL® 1 certified.

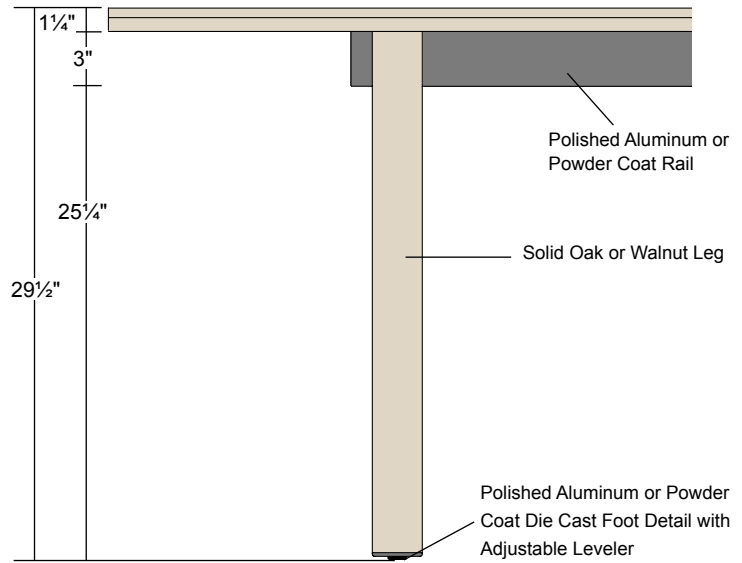

**Front View**

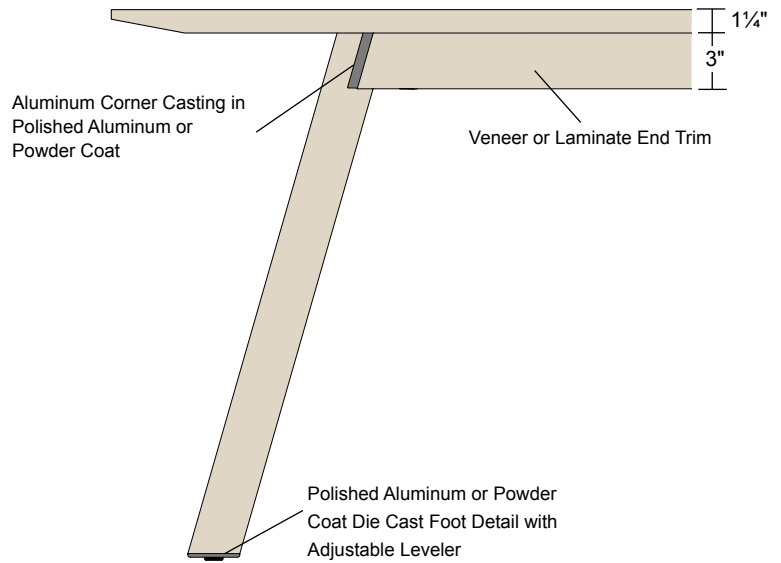

**Side View**

**Edge Details**

**Laminate**

- PLL** Solid Laminate
- WGL** Woodgrain Laminate

**Veneer**

- OAK** Oak
- WLT** Walnut

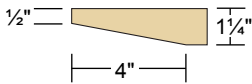

specification codes example: LKS-SKU-XXX

series	sku	grommet location
larkin		<b>larkin power</b> see pages 22-35 for location codes
		<b>under mount</b> see pages 38-39 for location codes
		<b>mediatrac1</b> see pages 44-47 for location codes
		<b>000</b> none
L   K   S   -	-	

material + finish code example: BK OAK 871 OAK 871

rail and feet finish	top material	top finish	base material	base finish
<b>PA</b> polished aluminum	<b>PLL</b> solid laminate	see finish pages	<b>OAK</b> oak	see finish pages
<b>powder coat upcharge</b>	<b>WGL</b> woodgrain laminate		<b>WLT</b> walnut	
<b>WH</b> satin white powder coat	<b>OAK</b> oak			
<b>EC</b> ecru powder coat	<b>WLT</b> walnut			
<b>LA</b> latte powder coat				
<b>AL</b> matte aluminum powder coat				
<b>GR</b> graphite powder coat				
<b>BZ</b> bronze powder coat				
<b>IG</b> iron grey powder coat				
<b>SG</b> sage powder coat				
<b>RD</b> black red powder coat				
<b>BK</b> matte black powder coat				

**Larkin Bases**



The Larkin conference table features an aluminum frame supported by solid wood legs equipped with adjustable levelers with a 1/2" range. Aluminum frames are available in polished or a range of powder coat finishes. Bases and tops are sold as a complete assembly.

Wood legs are available in solid oak or solid walnut with standard Bernhardt finishes. The Larkin conference table comes in a 4, 6, or 8 leg version. Table lengths up to 120" have 4 legs, lengths 126" to 222" have 6 legs and lengths 228" to 240" have 8 legs.

Larkin tables are SCS Indoor Advantage™ Gold and LEVEL 2 certified.

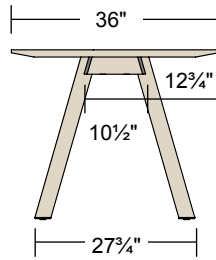

**Side View**

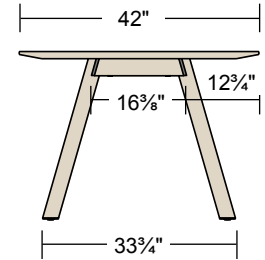

**Side View**

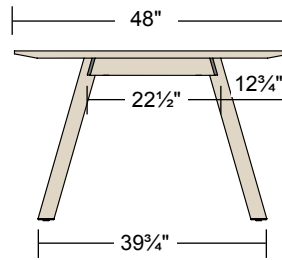

**Side View**

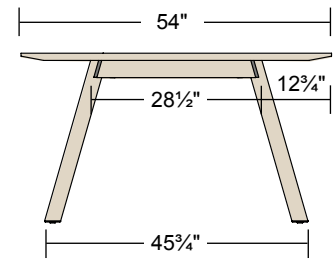

**Side View**

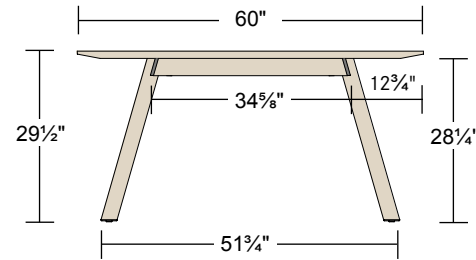

**Side View**

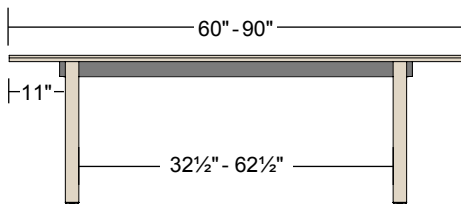

**Front View**

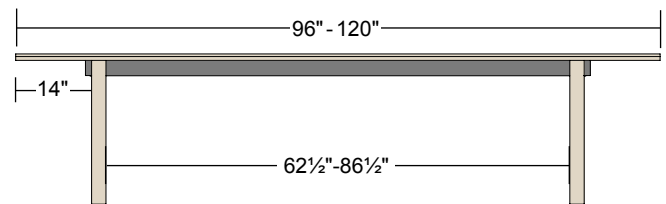

**Front View**

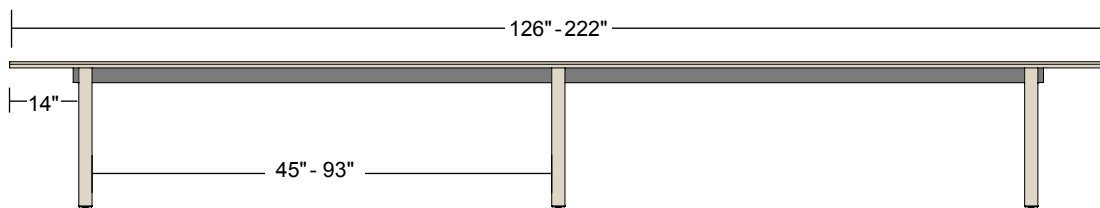

**Front View**

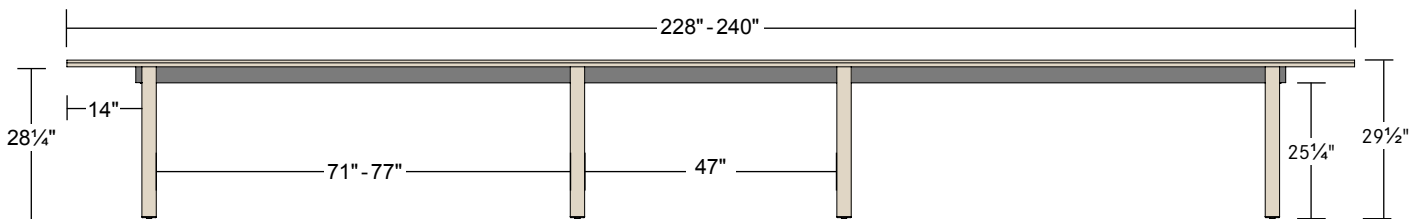

**Front View**



**Power Overview**



The Larkin meeting table collection offers a selection of power options designed to meet the diverse needs in today's work environment. Our traditional undermount and mediatrac1™ power are offered along with new Larkin surface mount power options. Larkin power options are tailor made and offer a variety of power options along with an integrated light that can be used with or without the power module.



**Larkin Power with Pass Thru**  
(3) Receptacles on the faceplate, (1) receptacle on the underside of the module, (4) USB-C ports and (1) pass thru location for HDMI or other cables. Available in white and graphite.



**Larkin Power**  
(3) Receptacles on the faceplate, (1) receptacle on the underside of the module and (4) USB-C ports. Available in white and graphite.



**Under Mount Power**  
(1) Grounded receptacle, (1) USB-A port and (1) USB-C port available as single corded or in multiples.



**Mediatrac1**  
(4) Grounded receptacles with open positions for (4) AAP plates.

**Larkin Power Overview**



The Larkin meeting table collection features custom, surface mount power options designed to allow for increased functionality on the work surface. Options are: the Larkin Power grommet, Larkin Power with pass thru, Larkin Power with light grommet and Larkin light.

The power grommet offers USB-C and receptable power only. The power with accessory grommet offers the choice of (2) faceplate options; a power with light grommet and power with pass thru for HDMI and other cables. The power with light option features an integrated light that plugs into a power module located conveniently beneath the table and features a USB-A port. An optical sensor is used to turn on, dim and turn off the light.

The Larkin light can be used within the power with light grommet or used separately on the table. When using the light separately and additional power is needed, under mount power can be specified. Offered in white and graphite, tables can accept 1-6 lights depending on the size of the table.

Power is certified to UL STD 962 A CSA STD 22.2 No. 21.

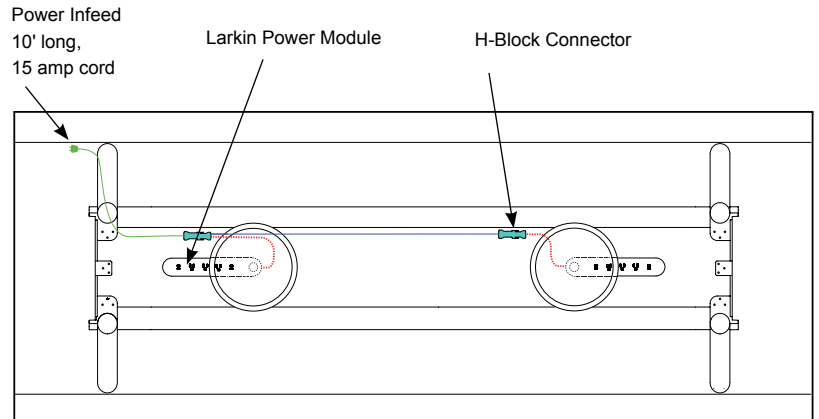

**Note:** Bernhardt Design provides recommendations for installation locations. End user installation will be required per individual sku. Power is specified separately.

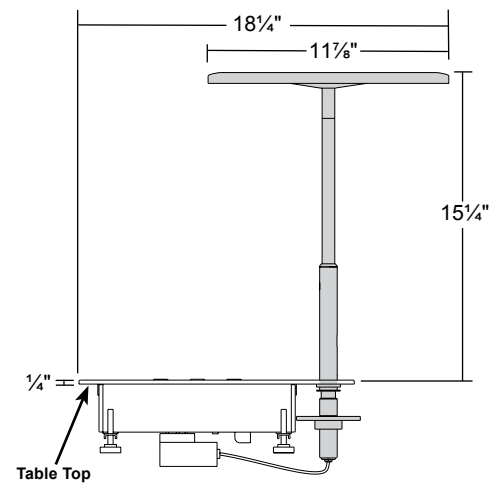

**Larkin Power with Light Grommet Side View**

**Larkin Power**

White or Graphite Finish

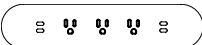

- (3) 15 amp receptacles, 120 v 60 Hz.
- (1) receptacle on the underside of the module
- (4) 2 amp USB-C ports, 20 watt
- 11 3/4" w x 2 1/2" d x 1/4" h above worksurface
- integrated circuit breaker
- UL 962 listed

**Larkin Power with Pass Thru Grommet**

White or Graphite Finish

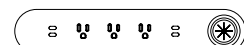

- (3) 15 amp receptacles, 120 v 60 Hz.
- (1) receptacle is on the underside of the module
- (4) 2 amp USB-C ports, 20 watt
- (1) cable pass thru
- 13 3/8" w x 2 1/2" d x 1/4" h above worksurface
- integrated circuit breaker
- UL 962 listed

**Larkin Power with Light Grommet**

White or Graphite Finish

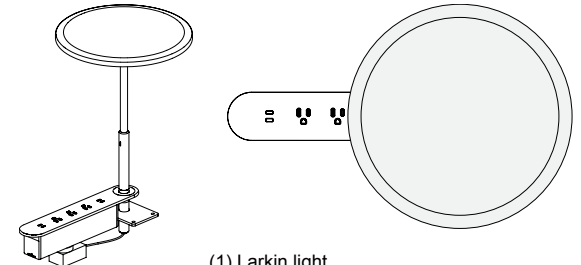

- (1) Larkin light
- (3) 15 amp receptacles, 120 v 60 Hz.
- (1) receptacle on the underside of the module
- (4) 2 amp USB-C ports, 20 watt
- (1) Integrated light pass through
- 13 3/8" w x 2 1/2" d x 1/4" h above worksurface
- 18 1/4" w x 11 7/8" d x 15 1/4" h - overall dimensions
- integrated circuit breaker
- UL 962 listed

**Jumper**

included in kit

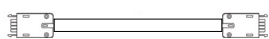

Jumper is determined by the length of the top specified and is included in the grommet code kit

**H-Block Connector**

Grey Finish  
included in kit



**Power Infeed**

included in kit

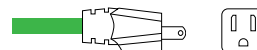

10' grounded 15 amp plug,  
Required per individual SKU,  
Braided Cord

**Larkin Wire Management**



The Larkin Conference collection offers a concealed wire management solution through the use of a cable pass thru. The cable pass thru is a plastic tray that is mounted in a pocket machined in the underside of the tabletop. This allows the cable to travel above the rail to the center of the table. The cable can then be routed down a leg with clear plastic clips, or down a drop down power tube.

A drop down power tube is recommended when using a floor core. The tube does not run all the way to ground to allow for flexibility of its location to any floor cores that may be used. The drop down power tube is sold separately.

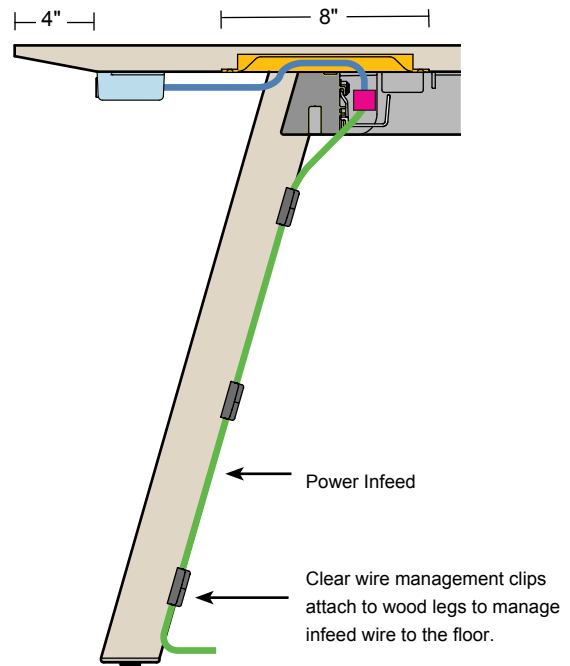

**Single Under Mount Shown**

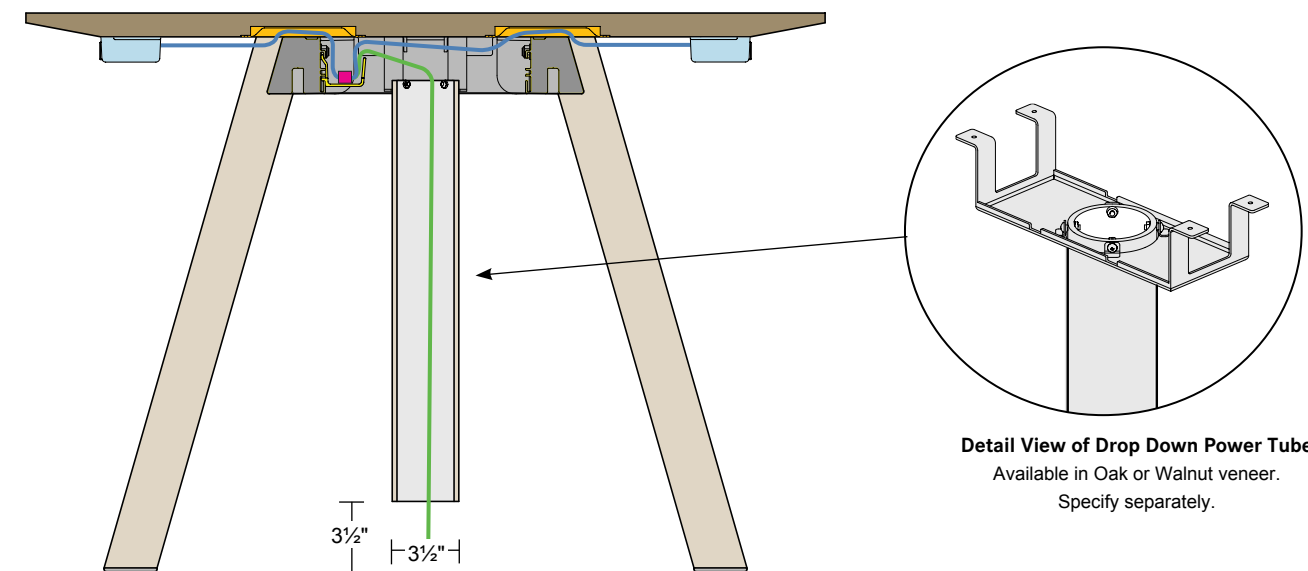

**Note:** End user installation will be required per individual sku. Drop Down Power Tube is specified separately. See accessory pages for add-ons.

rectangular tops - 4 leg assembly



rails and die cast feet are available in polished aluminum or powder coat, specify below  
mediatrac™ power not available on 36" width tables

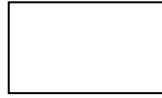

tops 60" - 120" length x 36" - 60" wide  
have one sectional top

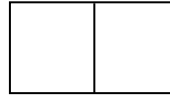

tops 126" - 240" length x 36" - 60" wide  
have two sectional tops

sku	l	w	h	legs	PLL	WGL	OAK	WLT
					solid laminate	woodgrain laminate	oak	walnut
EEA	60	36	29½"	(4) angled legs		5795		4830
EEB	60	42	29½"	(4) angled legs		5976		4980
EEC	60	48	29½"	(4) angled legs		6117		5098
EED	60	54	29½"	(4) angled legs		6303		5253
EFA	66	36	29½"	(4) angled legs		5884		4903
EFB	66	42	29½"	(4) angled legs		6091		5076
EFC	66	48	29½"	(4) angled legs		6248		5207
EFD	66	54	29½"	(4) angled legs		6433		5361
EFE	66	60	29½"	(4) angled legs		6647		5540
EGA	72	36	29½"	(4) angled legs		5978		4982
EGB	72	42	29½"	(4) angled legs		6140		5117
EGC	72	48	29½"	(4) angled legs		6364		5303
EGD	72	54	29½"	(4) angled legs		6575		5479
EGE	72	60	29½"	(4) angled legs		6789		5657
EHA	78	36	29½"	(4) angled legs		6076		5063
EHB	78	42	29½"	(4) angled legs		6045		5037
EHC	78	48	29½"	(4) angled legs		6454		5378
EHD	78	54	29½"	(4) angled legs		6691		5576
EHE	78	60	29½"	(4) angled legs		6929		5774

specification codes example: LKS-SKU-XXX

series	sku	grommet location
larkin		larkin power see pages 22-35 for location codes
		under mount see pages 38-39 for location codes
		mediatrac™ see pages 44-47 for location codes
		000 none
L   K   S   -	-	

material + finish code example: BK OAK 871 OAK 871

rail and feet finish	top material	top finish	base material	base finish
PA polished aluminum	PLL solid laminate	see finish pages	OAK oak	see finish pages
powder coat upcharge \$250	WGL woodgrain laminate		WLT walnut	
WH satin white powder coat	OAK oak			
EC ecru powder coat	WLT walnut			
LA latte powder coat				
AL matte aluminum powder coat				
GR graphite powder coat				
BZ bronze powder coat				
IG iron grey powder coat				
SG sage powder coat				
RD black red powder coat				
BK matte black powder coat				

rectangular tops - 4 leg assembly



rails and die cast feet are available in polished aluminum or powder coat, specify below  
mediatrac1™ power not available on 36" width tables

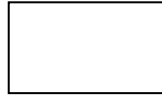

tops 60" - 120" length x 36" - 60" wide  
have one sectional top

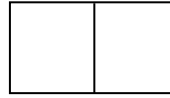

tops 126" - 240" length x 36" - 60" wide  
have two sectional tops

sku	l	w	h	legs	PLL	WGL	OAK	WLT
					solid laminate	woodgrain laminate	oak	walnut
EIA	84	36	29½"	(4) angled legs		6166		5138
EIB	84	42	29½"	(4) angled legs		6134		5112
EIC	84	48	29½"	(4) angled legs		6543		5452
EID	84	54	29½"	(4) angled legs		6748		5622
EIE	84	60	29½"	(4) angled legs		6953		5792
EJA	90	36	29½"	(4) angled legs		6586		5489
EJB	90	42	29½"	(4) angled legs		6605		5504
EJC	90	48	29½"	(4) angled legs		7014		5845
EJD	90	54	29½"	(4) angled legs		7219		6015
EJE	90	60	29½"	(4) angled legs		7424		6185
EKA	96	36	29½"	(4) angled legs		6676		5564
EKB	96	42	29½"	(4) angled legs		6698		5582
EKC	96	48	29½"	(4) angled legs		7112		5926
EKD	96	54	29½"	(4) angled legs		7317		6096
EKE	96	60	29½"	(4) angled legs		7522		6266
ELA	102	36	29½"	(4) angled legs		6766		5638
ELB	102	42	29½"	(4) angled legs		6792		5660
ELC	102	48	29½"	(4) angled legs		7200		6000
ELD	102	54	29½"	(4) angled legs		7405		6170
ELE	102	60	29½"	(4) angled legs		7610		6340

specification codes example: LKS-SKU-XXX

series	sku	grommet location
larkin		larkin power see pages 22-35 for location codes  under mount see pages 38-39 for location codes  mediatrac1™ see pages 44-47 for location codes  000 none
L   K   S   -	-	

material + finish code example: BK OAK 871 OAK 871

rail and feet finish	top material	top finish	base material	base finish
PA polished aluminum powder coat upcharge \$250 WH satin white powder coat EC ecru powder coat LA latte powder coat AL matte aluminum powder coat GR graphite powder coat BZ bronze powder coat IG iron grey powder coat SG sage powder coat RD black red powder coat BK matte black powder coat	PLL solid laminate WGL woodgrain laminate OAK oak WLT walnut	see finish pages	OAK oak WLT walnut	see finish pages

rectangular tops - 4 leg assembly



rails and die cast feet are available in polished aluminum or powder coat, specify below  
mediatrac1™ power not available on 36" width tables

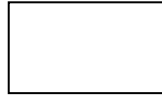

tops 60" - 120" length x 36" - 60" wide  
have one sectional top

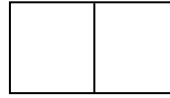

tops 126" - 240" length x 36" - 60" wide  
have two sectional tops

sku	l	w	h	legs	PLL	OAK
					WGL	WLT
EMA	108	36	29½"	(4) angled legs	7182	5985
EMB	108	42	29½"	(4) angled legs	7223	6019
EMC	108	48	29½"	(4) angled legs	7614	6345
EMD	108	54	29½"	(4) angled legs	7819	6515
EME	108	60	29½"	(4) angled legs	8024	6685
ENA	114	36	29½"	(4) angled legs	7281	6067
ENB	114	42	29½"	(4) angled legs	7488	6240
ENC	114	48	29½"	(4) angled legs	7805	6504
END	114	54	29½"	(4) angled legs	8108	6756
ENE	114	60	29½"	(4) angled legs	8411	7009
EOA	120	36	29½"	(4) angled legs	7373	6144
EOB	120	42	29½"	(4) angled legs	7603	6336
EOC	120	48	29½"	(4) angled legs	7920	6600
EOD	120	54	29½"	(4) angled legs	8235	6862
EOE	120	60	29½"	(4) angled legs	8578	7148

specification codes example: LKS-SKU-XXX

series	sku	grommet location
larkin		larkin power see pages 22-35 for location codes
		under mount see pages 38-39 for location codes
		mediatrac1™ see pages 44-47 for location codes
		000 none
L   K   S   -	-	

material + finish code example: BK OAK 871 OAK 871

rail and feet finish	top material	top finish	base material	base finish
PA polished aluminum	PLL solid laminate	see finish pages	OAK oak	see finish pages
power coat upcharge \$250	WGL woodgrain laminate		WLT walnut	
WH satin white powder coat	OAK oak			
EC ecru powder coat	WLT walnut			
LA latte powder coat				
AL matte aluminum powder coat				
GR graphite powder coat				
BZ bronze powder coat				
IG iron grey powder coat				
SG sage powder coat				
RD black red powder coat				
BK matte black powder coat				



rectangular tops - 6 leg assembly

rails and die cast feet are available in polished aluminum or powder coat, specify below  
mediatrac1™ power not available on 36" width tables



tops 60" - 120" length x 36" - 60" wide  
have one sectional top

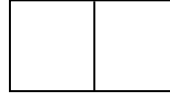

tops 126" - 240" length x 36" - 60" wide  
have two sectional tops

sku	l	w	h	legs	PLL	WGL	OAK	WLT
					solid laminate	woodgrain laminate	oak	walnut
EPA	126	36	29½"	(6) angled legs		10636		8863
EPB	126	42	29½"	(6) angled legs		11034		9195
EPC	126	48	29½"	(6) angled legs		11366		9471
EPD	126	54	29½"	(6) angled legs		11650		9708
EPE	126	60	29½"	(6) angled legs		12034		10028
EQA	132	36	29½"	(6) angled legs		10895		9080
EQB	132	42	29½"	(6) angled legs		11139		9282
EQC	132	48	29½"	(6) angled legs		11507		9589
EQD	132	54	29½"	(6) angled legs		11791		9826
EQE	132	60	29½"	(6) angled legs		12175		10146
ERA	138	36	29½"	(6) angled legs		10985		9155
ERB	138	42	29½"	(6) angled legs		11227		9356
ERC	138	48	29½"	(6) angled legs		11596		9663
ERD	138	54	29½"	(6) angled legs		11880		9900
ERE	138	60	29½"	(6) angled legs		12289		10241
ESA	144	36	29½"	(6) angled legs		11090		9242
ESB	144	42	29½"	(6) angled legs		11334		9445
ESC	144	48	29½"	(6) angled legs		11703		9752
ESD	144	54	29½"	(6) angled legs		11987		9989
ESE	144	60	29½"	(6) angled legs		12418		10349

specification codes example: LKS-SKU-XXX

series	sku	grommet location
larkin		<p><b>larkin power</b> see pages 22-35 for location codes</p> <p><b>under mount</b> see pages 38-39 for location codes</p> <p><b>mediatrac1™</b> see pages 44-47 for location codes</p> <p><b>000</b> none</p>
L   K   S   -	-	

material + finish code example: BK OAK 871 OAK 871

rail and feet finish	top material	top finish	base material	base finish
<p><b>PA</b> polished aluminum</p> <p><b>WH</b> satin white powder coat</p> <p><b>EC</b> ecru powder coat</p> <p><b>LA</b> latte powder coat</p> <p><b>AL</b> matte aluminum powder coat</p> <p><b>GR</b> graphite powder coat</p> <p><b>BZ</b> bronze powder coat</p> <p><b>IG</b> iron grey powder coat</p> <p><b>SG</b> sage powder coat</p> <p><b>RD</b> black red powder coat</p> <p><b>BK</b> matte black powder coat</p>	<p><b>PLL</b> solid laminate</p> <p><b>WGL</b> woodgrain laminate</p> <p><b>OAK</b> oak</p> <p><b>WLT</b> walnut</p>	see finish pages	<p><b>OAK</b> oak</p> <p><b>WLT</b> walnut</p>	see finish pages



rectangular tops - 6 leg assembly

rails and die cast feet are available in polished aluminum or powder coat, specify below  
mediatrac1™ power not available on 36" width tables

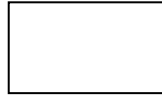

tops 60" - 120" length x 36" - 60" wide  
have one sectional top

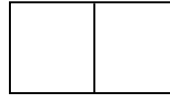

tops 126" - 240" length x 36" - 60" wide  
have two sectional tops

sku	l	w	h	legs	PLL	WGL	OAK	WLT
					solid laminate	woodgrain laminate	oak	walnut
ETA	150	36	29½"	(6) angled legs		11175		9312
ETB	150	42	29½"	(6) angled legs		11423		9519
ETC	150	48	29½"	(6) angled legs		11791		9826
ETD	150	54	29½"	(6) angled legs		12076		10063
ETE	150	60	29½"	(6) angled legs		12529		10441
EUA	156	36	29½"	(6) angled legs		11279		9399
EUB	156	42	29½"	(6) angled legs		11525		9604
EUC	156	48	29½"	(6) angled legs		11894		9912
EUD	156	54	29½"	(6) angled legs		12178		10149
EUE	156	60	29½"	(6) angled legs		12654		10545
EVA	162	36	29½"	(6) angled legs		11364		9470
EVB	162	42	29½"	(6) angled legs		11614		9678
EVC	162	48	29½"	(6) angled legs		11983		9986
EVD	162	54	29½"	(6) angled legs		12267		10223
EVE	162	60	29½"	(6) angled legs		12765		10637
EWA	168	36	29½"	(6) angled legs		11464		9554
EWB	168	42	29½"	(6) angled legs		12191		10160
EWC	168	48	29½"	(6) angled legs		12520		10434
EWD	168	54	29½"	(6) angled legs		12805		10671
EWE	168	60	29½"	(6) angled legs		13325		11104

specification codes example: LKS-SKU-XXX

series	sku	grommet location
larkin		larkin power see pages 22-35 for location codes  under mount see pages 38-39 for location codes  mediatrac1™ see pages 44-47 for location codes  000 none
L   K   S   -	-	

material + finish code example: BK OAK 871 OAK 871

rail and feet finish	top material	top finish	base material	base finish
PA polished aluminum powder coat upcharge \$300 WH satin white powder coat EC ecru powder coat LA latte powder coat AL matte aluminum powder coat GR graphite powder coat BZ bronze powder coat IG iron grey powder coat SG sage powder coat RD black red powder coat BK matte black powder coat	PLL solid laminate WGL woodgrain laminate OAK oak WLT walnut	see finish pages	OAK oak WLT walnut	see finish pages





rectangular tops - 6 leg assembly

rails and die cast feet are available in polished aluminum or powder coat, specify below  
mediatrac1™ power not available on 36" width tables

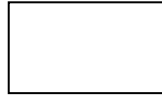

tops 60" - 120" length x 36" - 60" wide  
have one sectional top

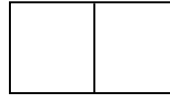

tops 126" - 240" length x 36" - 60" wide  
have two sectional tops

sku	l	w	h	legs	PLL	WGL	OAK	WLT
					solid laminate	woodgrain laminate	oak	walnut
EXA	174	36	29½"	(6) angled legs		12193		10161
EXB	174	42	29½"	(6) angled legs		13520		11267
EXC	174	48	29½"	(6) angled legs		13889		11574
EXD	174	54	29½"	(6) angled legs		14174		11811
EXE	174	60	29½"	(6) angled legs		14716		12263
EYA	180	36	29½"	(6) angled legs		12915		10763
EYB	180	42	29½"	(6) angled legs		14231		11860
EYC	180	48	29½"	(6) angled legs		14600		12167
EYD	180	54	29½"	(6) angled legs		14885		12404
EYE	180	60	29½"	(6) angled legs		15449		12874
EZA	186	36	29½"	(6) angled legs		13030		10859
EZB	186	42	29½"	(6) angled legs		14347		11956
EZC	186	48	29½"	(6) angled legs		14716		12263
EZD	186	54	29½"	(6) angled legs		15000		12500
EZE	186	60	29½"	(6) angled legs		15587		12989
E1A	192	36	29½"	(6) angled legs		13110		10925
E1B	192	42	29½"	(6) angled legs		14436		12030
E1C	192	48	29½"	(6) angled legs		14805		12337
E1D	192	54	29½"	(6) angled legs		15089		12574
E1E	192	60	29½"	(6) angled legs		15698		13082

specification codes example: LKS-SKU-XXX

series	sku	grommet location
larkin		<p><b>larkin power</b> see pages 22-35 for location codes</p> <p><b>under mount</b> see pages 38-39 for location codes</p> <p><b>mediatrac1™</b> see pages 44-47 for location codes</p> <p><b>000</b> none</p>
L   K   S   -	-	

material + finish code example: BK OAK 871 OAK 871

rail and feet finish	top material	top finish	base material	base finish
<p><b>PA</b> polished aluminum</p> <p><b>WH</b> satin white powder coat</p> <p><b>EC</b> ecru powder coat</p> <p><b>LA</b> latte powder coat</p> <p><b>AL</b> matte aluminum powder coat</p> <p><b>GR</b> graphite powder coat</p> <p><b>BZ</b> bronze powder coat</p> <p><b>IG</b> iron grey powder coat</p> <p><b>SG</b> sage powder coat</p> <p><b>RD</b> black red powder coat</p> <p><b>BK</b> matte black powder coat</p>	<p><b>PLL</b> solid laminate</p> <p><b>WGL</b> woodgrain laminate</p> <p><b>OAK</b> oak</p> <p><b>WLT</b> walnut</p>	see finish pages	<p><b>OAK</b> oak</p> <p><b>WLT</b> walnut</p>	see finish pages



rectangular tops - 6 leg assembly

rails and die cast feet are available in polished aluminum or powder coat, specify below  
mediatrac1™ power not available on 36" width tables



tops 60" - 120" length x 36" - 60" wide  
have one sectional top



tops 126" - 240" length x 36" - 60" wide  
have two sectional tops

sku	l	w	h	legs	PLL	WGL	OAK	WLT
					solid laminate	woodgrain laminate	oak	walnut
E2A	198	36	29½"	(6) angled legs		13209		11008
E2B	198	42	29½"	(6) angled legs		14538		12115
E2C	198	48	29½"	(6) angled legs		14907		12423
E2D	198	54	29½"	(6) angled legs		15191		12660
E2E	198	60	29½"	(6) angled legs		15823		13186
E3A	204	36	29½"	(6) angled legs		13298		11082
E3B	204	42	29½"	(6) angled legs		14627		12189
E3C	204	48	29½"	(6) angled legs		14996		12497
E3D	204	54	29½"	(6) angled legs		15280		12734
E3E	204	60	29½"	(6) angled legs		15934		13278
E4A	210	36	29½"	(6) angled legs		13388		11157
E4B	210	42	29½"	(6) angled legs		14725		12271
E4C	210	48	29½"	(6) angled legs		15094		12578
E4D	210	54	29½"	(6) angled legs		15369		12808
E4E	210	60	29½"	(6) angled legs		16054		13378
E5A	216	36	29½"	(6) angled legs		13493		11244
E5B	216	42	29½"	(6) angled legs		14823		12352
E5C	216	48	29½"	(6) angled legs		15245		12704
E5D	216	54	29½"	(6) angled legs		15467		12889
E5E	216	60	29½"	(6) angled legs		16174		13478

specification codes example: LKS-SKU-XXX

series	sku	grommet location
larkin		larkin power see pages 22-35 for location codes
		under mount see pages 38-39 for location codes
		mediatrac1™ see pages 44-47 for location codes
		000 none
L   K   S   -	-	

material + finish code example: BK OAK 871 OAK 871

rail and feet finish	top material	top finish	base material	base finish
PA polished aluminum	PLL solid laminate	see finish pages	OAK oak	see finish pages
powder coat upcharge \$300	WGL woodgrain laminate		WLT walnut	
WH satin white powder coat	OAK oak			
EC ecru powder coat	WLT walnut			
LA latte powder coat				
AL matte aluminum powder coat				
GR graphite powder coat				
BZ bronze powder coat				
IG iron grey powder coat				
SG sage powder coat				
RD black red powder coat				
BK matte black powder coat				



rectangular tops - 6 leg assembly

rails and die cast feet are available in polished aluminum or powder coat, specify below  
mediatrac1™ power not available on 36" width tables



tops 60" - 120" length x 36" - 60" wide  
have one sectional top

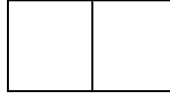

tops 126" - 240" length x 36" - 60" wide  
have two sectional tops

sku	l	w	h	legs	PLL	WGL	OAK	WLT
					solid laminate	woodgrain laminate	oak	walnut
E6A	222	36	29½"	(6) angled legs		13577		11315
E6B	222	42	29½"	(6) angled legs		14911		12426
E6C	222	48	29½"	(6) angled legs		15423		12852
E6D	222	54	29½"	(6) angled legs		15734		13111
E6E	222	60	29½"	(6) angled legs		16285		13571

specification codes example: LKS-SKU-XXX

series	sku	grommet location
larkin		<p><b>larkin power</b> see pages 22-35 for location codes</p> <p><b>under mount</b> see pages 38-39 for location codes</p> <p><b>mediatrac1™</b> see pages 44-47 for location codes</p> <p><b>000</b> none</p>
L   K   S   -	-	

material + finish code example: BK OAK 871 OAK 871

rail and feet finish	top material	top finish	base material	base finish
<p><b>PA</b> polished aluminum</p> <p><b>WH</b> satin white powder coat</p> <p><b>EC</b> ecru powder coat</p> <p><b>LA</b> latte powder coat</p> <p><b>AL</b> matte aluminum powder coat</p> <p><b>GR</b> graphite powder coat</p> <p><b>BZ</b> bronze powder coat</p> <p><b>IG</b> iron grey powder coat</p> <p><b>SG</b> sage powder coat</p> <p><b>RD</b> black red powder coat</p> <p><b>BK</b> matte black powder coat</p>	<p><b>PLL</b> solid laminate</p> <p><b>WGL</b> woodgrain laminate</p> <p><b>OAK</b> oak</p> <p><b>WLT</b> walnut</p>	see finish pages	<p><b>OAK</b> oak</p> <p><b>WLT</b> walnut</p>	see finish pages

rectangular tops - 8 leg assembly

rails and die cast feet are available in polished aluminum or powder coat, specify below  
mediatrac1™ power not available on 36" width tables



tops 60" - 120" length x 36" - 60" wide  
have one sectional top



tops 126" - 240" length x 36" - 60" wide  
have two sectional tops

sku	l	w	h	legs	PLL	OAK
					WGL	WLT
E7A	228	36	29½"	(8) angled legs	15013	12511
E7B	228	42	29½"	(8) angled legs	15388	12824
E7C	228	48	29½"	(8) angled legs	15937	13281
E7D	228	54	29½"	(8) angled legs	16511	13759
E7E	228	60	29½"	(8) angled legs	16859	14049
E8A	234	36	29½"	(8) angled legs	15102	12585
E8B	234	42	29½"	(8) angled legs	15504	12920
E8C	234	48	29½"	(8) angled legs	16053	13377
E8D	234	54	29½"	(8) angled legs	16626	13855
E8E	234	60	29½"	(8) angled legs	17202	14335
E9A	240	36	29½"	(8) angled legs	15191	12659
E9B	240	42	29½"	(8) angled legs	15593	12994
E9C	240	48	29½"	(8) angled legs	16178	13482
E9D	240	54	29½"	(8) angled legs	16767	13973
E9E	240	60	29½"	(8) angled legs	17369	14474

specification codes example: LKS-SKU-XXX

series	sku	grommet location
larkin		<p><b>larkin power</b> see pages 22-35 for location codes</p> <p><b>under mount</b> see pages 38-39 for location codes</p> <p><b>mediatrac1™</b> see pages 44-47 for location codes</p> <p>000 none</p>
L   K   S   -	-	

material + finish code example: BK OAK 871 OAK 871

rail and feet finish	top material	top finish	base material	base finish
<p>PA polished aluminum</p> <p><b>powder coat upcharge \$350</b></p> <p>WH satin white powder coat</p> <p>EC ecru powder coat</p> <p>LA latte powder coat</p> <p>AL matte aluminum powder coat</p> <p>GR graphite powder coat</p> <p>BZ bronze powder coat</p> <p>IG iron grey powder coat</p> <p>SG sage powder coat</p> <p>RD black red powder coat</p> <p>BK matte black powder coat</p>	<p>PLL solid laminate</p> <p>WGL woodgrain laminate</p> <p>OAK oak</p> <p>WLT walnut</p>	see finish pages	<p>OAK oak</p> <p>WLT walnut</p>	see finish pages



power + accessories

**Larkin Grommet Placement Kits**

Larkin power options by Bernhardt Design are offered as a grommet kit which includes all lights, grommets, jumpers and necessary components needed to bring power from the floor to the user. The number of grommets and lengths of jumpers are determined by the lengths and power options selected. Your kit will come complete with all necessary parts to install in the field.

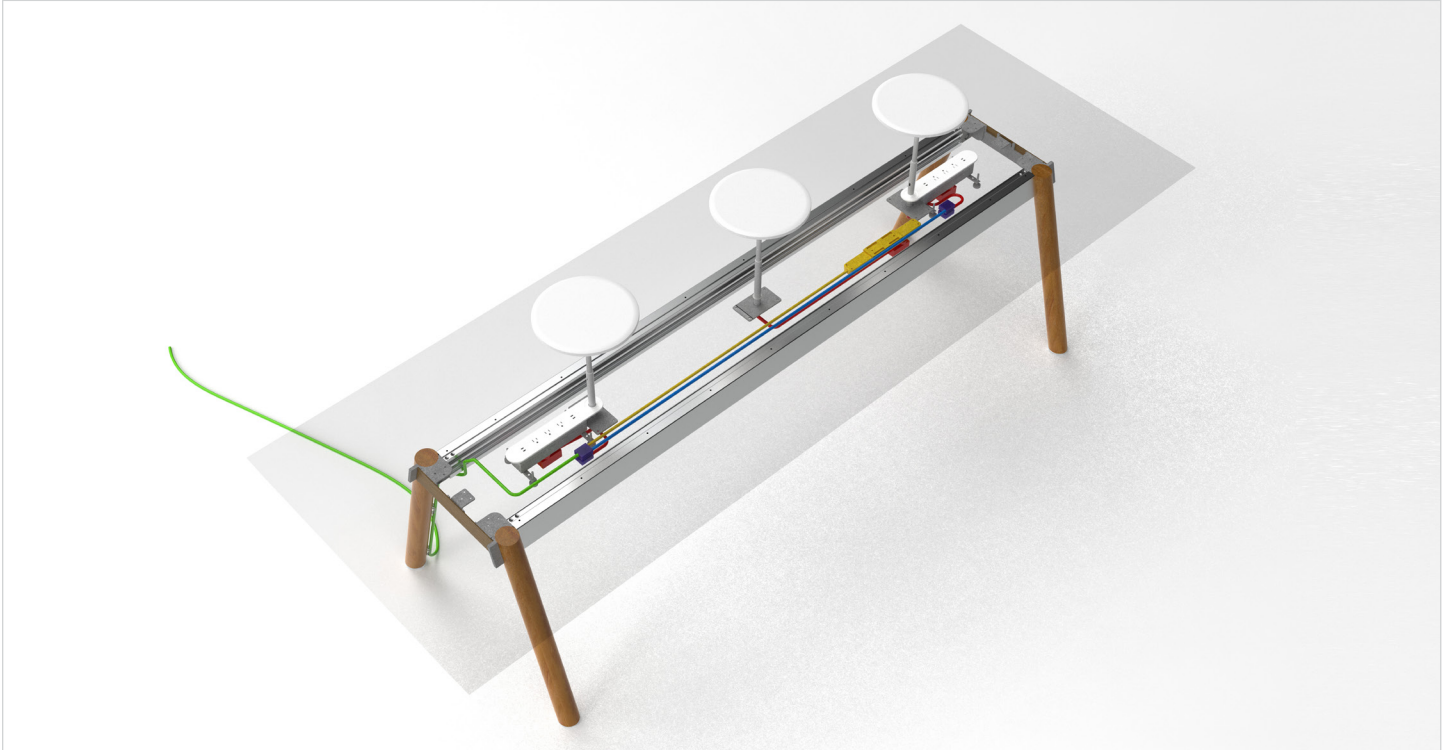

**Ordering Larkin Power Grommets**

- Determine the amount of power and data needed
- Select the grommet code that best suits your requirements
- Select the power option
- Select the length of table that this is to be used on  
*(make sure that this grommet code matches the code used when ordering your top)*
- Select the faceplate finish

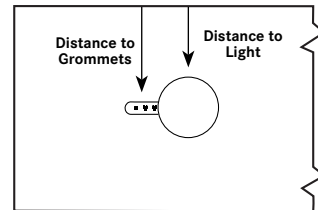

The Grommet Kit will ship separately and will be installed in the field.

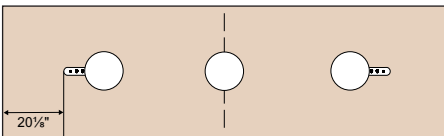

**Ordering Example:**  
120" x 60" Table Top  
Oak veneer, 870 finish  
WH Faceplate Finish  
LKS-LP3-CRD-120

Top Depth	Distance to Grommet	Distance to Light
42"	19 3/4"	15"
48"	22 3/4"	18"
54"	25 3/4"	21"
60"	28 3/4"	24"

**specification codes example: LKS-SKU-CRD-240**

series	sku	power option	table length
Larkin		CRD corded	060 108 156 204 066 114 162 210 072 120 168 216 078 126 174 222 084 132 180 228 090 138 186 234 096 144 192 240 102 150 198
L   K   S   -	-		

**Important:**  
Specify the length of the table that your configuration is to go on, this will insure the proper length of wiring is provided in the kit.

**faceplate finish code example: WH**

faceplate finish
GR graphite
WH white

**Larkin Power**

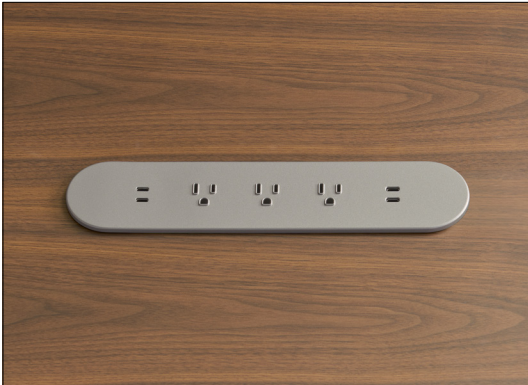

Larkin power module offers (3) receptacles on the faceplate, (1) receptacle on the underside of the module and (4) USB-C ports allowing for accessibility of power on the table top. Multiple grommets can be used on the table top depending on the size of the table.

Certified to UL STD 962 A CSA STD 22.2 No 21.

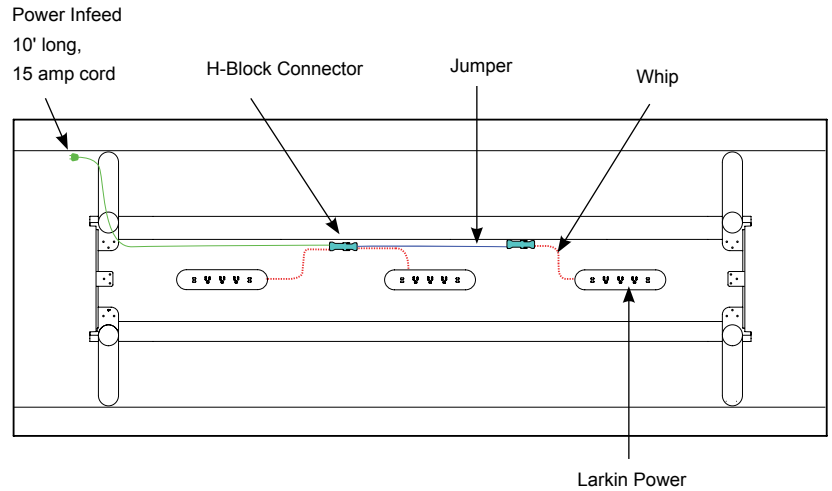

**Note:** Bernhardt Design provides recommendations for installation locations on the following pages. Further installation instructions are included with each power unit. End user installation will be required per individual sku. Power is specified separately.

**Larkin Power**

White or Graphite Finish

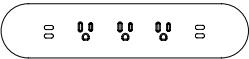

- (3) 15 amp receptacles, 120 v 60 Hz.
- (1) receptacle on the underside of the module
- (4) 2 amp USB-C ports, 20 watt
- 11¾" w x 2½" d x ¼" h above worksurface
- integrated circuit breaker
- UL 962 listed

**H-Block Connector**

Grey Finish  
included in kit

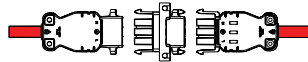

Not used with corded or hardwired modules

**Power Infeed**

included in kit

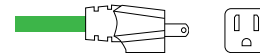

10' Grounded, 15 amp plug,  
Braided Cord

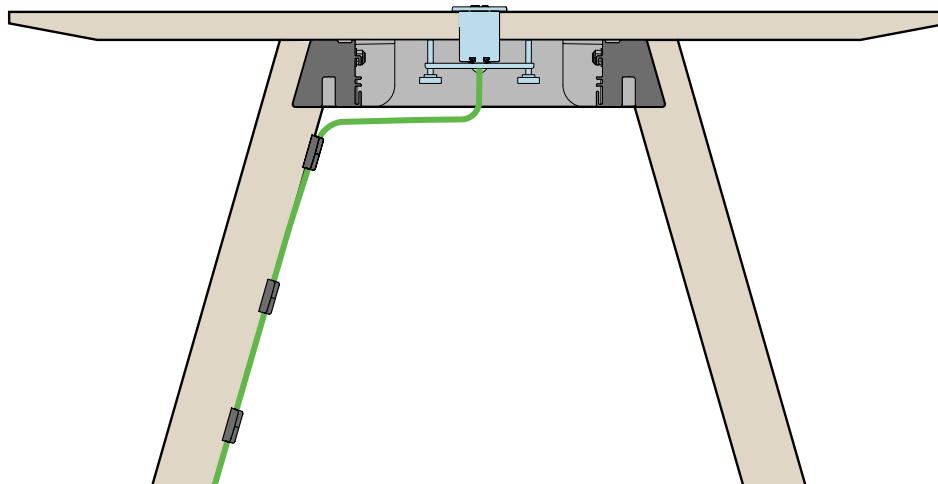

**Single Larkin Power**

**Larkin Power**

Grommet kits and locations codes for veneer and laminate tops.  
Kits include all jumpers and necessary components based on table length and power option.  
Grommet kits ship separately from tops.

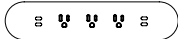

sku	descriptions	price
LK1	<b>60" - 240" Tables      36" - 60" Wide</b>	\$ 2150
LK2	<b>84" - 240" Tables      36" - 60" Wide</b>	3500
LK3	<b>108" - 240" Tables      36" - 60" Wide</b>	4900

**specification codes example: LKS-SKU-CRD-240**

series	sku	power option	table length
Larkin		CRD corded	060 108 156 204
			066 114 162 210
			072 120 168 216
			078 126 174 222
			084 132 180 228
			090 138 186 234
			096 144 192 240
			102 150 198

**Important:**  
Specify the length of the table that your configuration is to go on, this will insure the proper length of wiring is provided in the kit.

**faceplate finish code example: WH**

faceplate finish
GR graphite
WH white



**Larkin Power**

Grommet kits and locations codes for veneer and laminate tops.  
Kits include all jumpers and necessary components based on table length and power option.  
Grommet kits ship separately from tops.

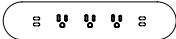

sku	descriptions	price
LK4	144" - 240" Tables 36" - 60" Wide	\$ 6300
LK5	180" - 240" Tables 36" - 60" Wide	7700
LK6	228" - 240" Tables 36" - 60" Wide	9150

specification codes example: LKS-SKU-CRD-240

series	sku	power option	table length
Larkin		CRD corded	144 180 216
			150 186 222
			156 192 228
			162 198 234
			168 204 240
			174 210

**Important:**  
Specify the length of the table that your configuration is to go on, this will insure the proper length of wiring is provided in the kit.

faceplate finish code example: WH

faceplate finish
GR graphite
WH white

**Larkin Power with Pass Thru Grommet**



The power with pass thru grommet offers a cable pass thru, (3) receptacles on the faceplate, (1) receptacle on the underside of the module and (4) USB-C ports allowing for accessibility of power on the table top. Multiple grommets can be used on the table top depending on the size of the table.

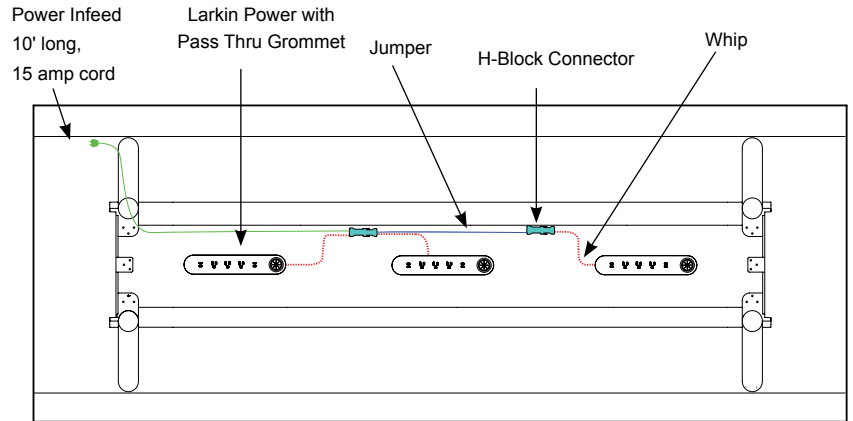

**Note:** Bernhardt Design provides recommendations for installation locations on the following pages. Further installation instructions are included with each power unit. End user installation will be required per individual sku. Power is specified separately.

Certified to UL STD 962 A CSA STD 22.2 No 21.

**Power with Pass Thru Grommet**

White or Graphite Finish

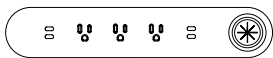

- (3) 15 amp receptacles, 120 v 60 Hz.
- (1) receptacle on the underside of the module
- (4) 2 amp USB-C ports, 20 watt
- (1) cable pass thru
- 13 3/4" w x 2 1/2" d x 1/4" h above worksurface
- integrated circuit breaker
- UL 962 listed

**Jumper**

included in kit  
(if required)



Jumper is determined by the length of the top specified and is included in the grommet code kit

**H-Block Connector**

Grey Finish  
included in kit

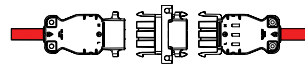

**Power Infeed**

included in kit

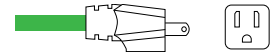

10' grounded 15 amp plug,  
Braided Cord

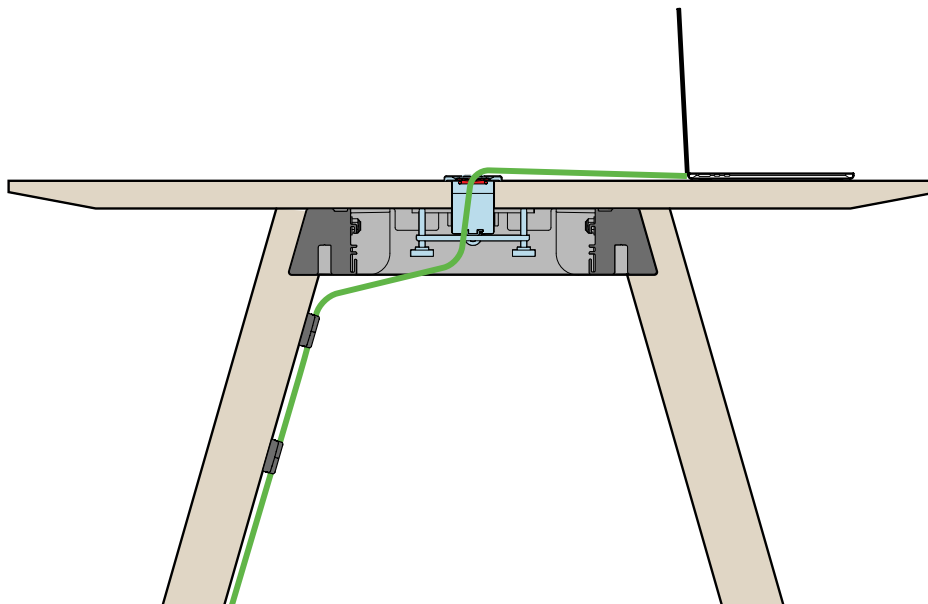

**HDMI Cord Connected to a Laptop for Presentation Purposes**

**Larkin Power with Pass Thru Grommet**

Grommet kits and locations codes for veneer and laminate tops.  
Kits include all jumpers and necessary components based on table length and power option.  
Grommet kits ship separately from tops.

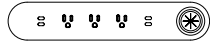

sku	descriptions	price
LG1	<b>60" - 240" Tables      36" - 60" Wide</b>	\$ 2250
LG2	<b>84" - 240" Tables      36" - 60" Wide</b>	3700
LG3	<b>108" - 240" Tables      36" - 60" Wide</b>	5200

**specification codes example: LKS-SKU-CRD-240**

series	sku	power option	table length
Larkin		CRD corded	060 108 156 204
			066 114 162 210
			072 120 168 216
			078 126 174 222
			084 132 180 228
			090 138 186 234
			096 144 192 240
			102 150 198

**Important:**  
Specify the length of the table that your configuration is to go on, this will insure the proper length of wiring is provided in the kit.

**faceplate finish code example: WH**

faceplate finish
GR graphite
WH white

**Larkin Power with Pass Thru Grommet**

Grommet kits and locations codes for veneer and laminate tops.  
Kits include all jumpers and necessary components based on table length and power option.  
Grommet kits ship separately from tops.

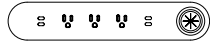

sku	descriptions	price
<b>LG4</b>	<b>144" - 240" Tables      36" - 60" Wide</b>	<b>\$ 6700</b>
<b>LG5</b>	<b>180" - 240" Tables      36" - 60" Wide</b>	<b>8200</b>
<b>LG6</b>	<b>228" - 240" Tables      36" - 60" Wide</b>	<b>9750</b>

**specification codes example: LKS-SKU-CRD-240**

series	sku	power option	table length
Larkin		CRD corded	144 180 216
			150 186 222
			156 192 228
			162 198 234
			168 204 240
			174 210

**Important:**  
Specify the length of the table that your configuration is to go on, this will insure the proper length of wiring is provided in the kit.

**faceplate finish code example: WH**

faceplate finish
GR graphite
WH white

**Larkin Power with Light Grommet**



The power with light grommet features an integrated light that plugs into a power module underneath the table. The light features a USB-A port and is available in white and graphite. An optical sensor is used to turn on, dim and turn off the light.

The power module also offers (3) receptacles on the faceplate, (1) receptacle on the underside of the module and (4) USB-C ports allowing for accessibility of power on the table top. Multiple grommets can be used on the table top depending on the size of the table.

Certified to UL STD 962 A CSA STD 22.2 No 21.

**Larkin Power with Light Grommet**

White or Graphite Finish

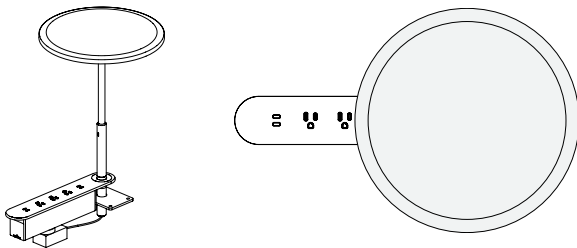

- (1) Larkin Light
- (3) 15 amp receptacles, 120 v 60 Hz.
- (1) receptacle on the underside of the module
- (4) 2 amp USB-C ports, 20 watt
- (1) Integrated light pass through  
13<sup>5</sup>/<sub>8</sub>"w x 2<sup>1</sup>/<sub>2</sub>"d x 1<sup>1</sup>/<sub>4</sub>"h above worksurface  
18<sup>1</sup>/<sub>4</sub>"w x 11<sup>1</sup>/<sub>8</sub>" x 15<sup>1</sup>/<sub>4</sub>"h overall dimensions  
integrated circuit breaker  
UL 962 listed

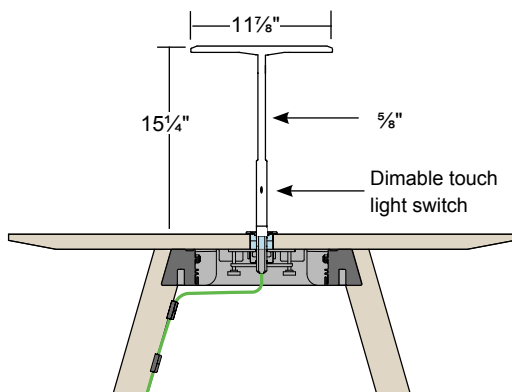

**Section View**  
Showing Light Dimensions

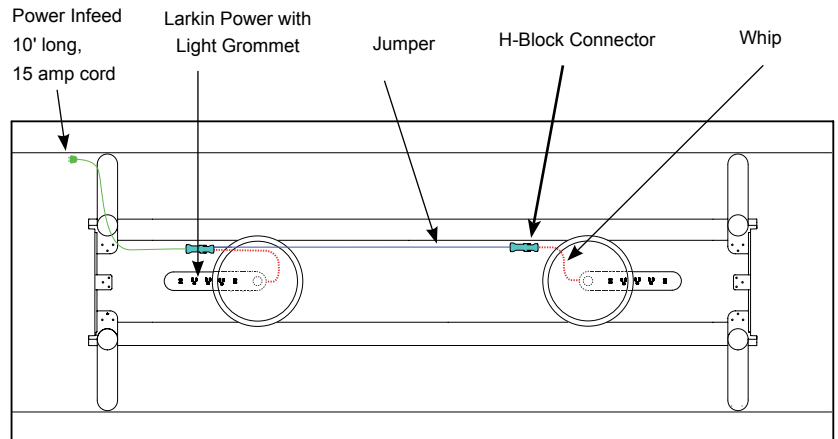

**Note:** Bernhardt Design provides recommendations for installation locations on the following pages. Further installation instructions are included with each power unit. End user installation will be required per individual sku. Power is specified separately.

**Jumper**

included in kit  
(if required)

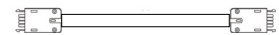

Jumper is determined by the length of the top specified and is included in the grommet code kit

**H-Block Connector**

Grey Finish  
included in kit



**Power Infeed**

included in kit

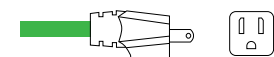

10' Grounded 15 amp plug,  
Braided Cord

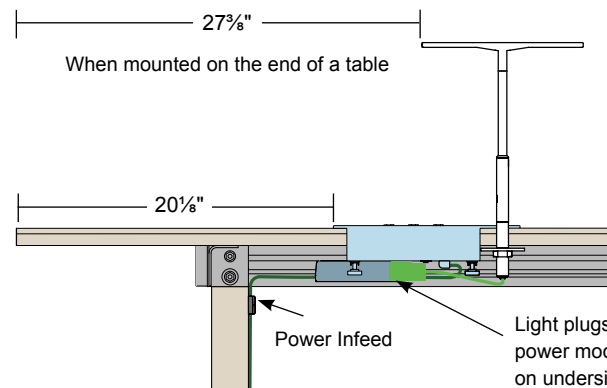

**Front View**

**Larkin Power with Light Grommet**

Grommet kits and locations codes for veneer and laminate tops.  
Kits include Larkin light and all jumpers and necessary components based on table length and power option.  
Grommet kits ship separately from tops.

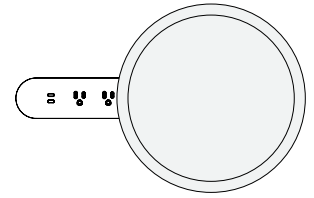

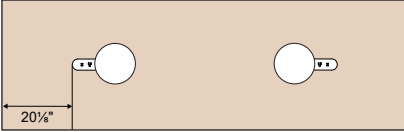
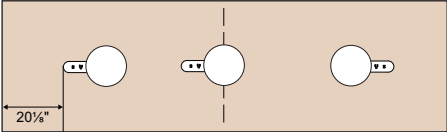
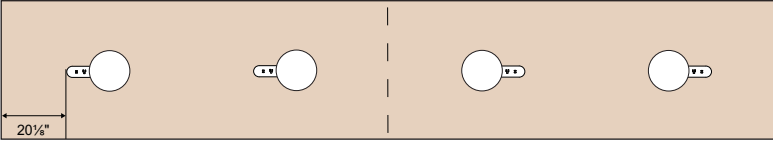
sku	descriptions	price
LT2	<b>90" - 240" Tables      36" - 60" Wide</b>	\$ 7250
		
LT3	<b>120" - 240" Tables      36" - 60" Wide</b>	10600
		
LT4	<b>144" - 240" Tables      36" - 60" Wide</b>	13800
		

**specification codes example: LKS-SKU-CRD-240**

series	sku	power option	table length			
Larkin		CRD corded	090	132	168	204
			096	138	174	210
			102	144	180	216
			108	150	186	222
			114	156	192	234
			120	162	198	240
			126			

**Important:**  
Specify the length of the table that your configuration is to go on, this will insure the proper length of wiring is provided in the kit.

**faceplate finish code example: WH**

faceplate finish
GR graphite
WH white

### Larkin Power with Light Grommet

Grommet kits and locations codes for veneer and laminate tops.  
Kits include Larkin light and all jumpers and necessary components based on table length and power option.  
Grommet kits ship separately from tops.

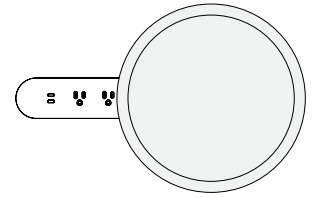

sku	descriptions	price
LT5	<b>180" - 240" Tables    36" - 60" Wide</b>	\$ 17100
LT6	<b>228" - 240" Tables    36" - 60" Wide</b>	20300

**specification codes example: LKS-SKU-CRD-240**

series	sku	power option	table length
Larkin		CRD corded	180 210 186 216 192 222 198 234 204 240
L   K   S   -	-		

**Important:**  
Specify the length of the table that your configuration is to go on, this will insure the proper length of wiring is provided in the kit.

**faceplate finish code example: WH**

faceplate finish
GR graphite WH white

**Larkin Light - Only**



Larkin offers a custom power module with an integrated light that plugs into a power module underneath the table. The light features a USB-A port and is available in white and graphite. An optical sensor is used to turn on, dim and turn off the light. Depending on the size of the table, 1-6 lights can be used.

Under mount power is certified to UL STD 962 A CSA STD 22.2 No. 21.

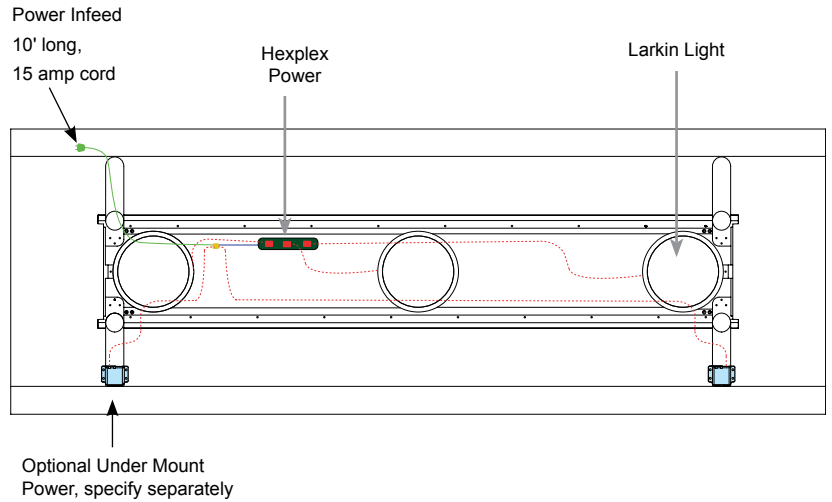

**Note:** Bernhardt Design provides recommendations for installation locations on the following pages. Further installation instructions are included with each power unit. End user installation will be required per individual sku. Power is specified separately.

**Larkin Light**

White or Graphite Finish

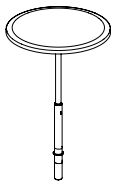

(1) USB-A port  
5 watt  
Dimmable touch light switch

**Hexplex**

Matte Black Finish

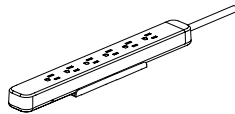

(5) 15 amp receptacles,  
120 v 60 Hz.

**H-Block Connector**

Grey Finish  
included in kit

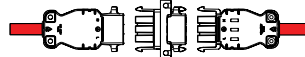

**Power Infeed**

included in kit



10' grounded 15 amp plug,  
Braided Cord

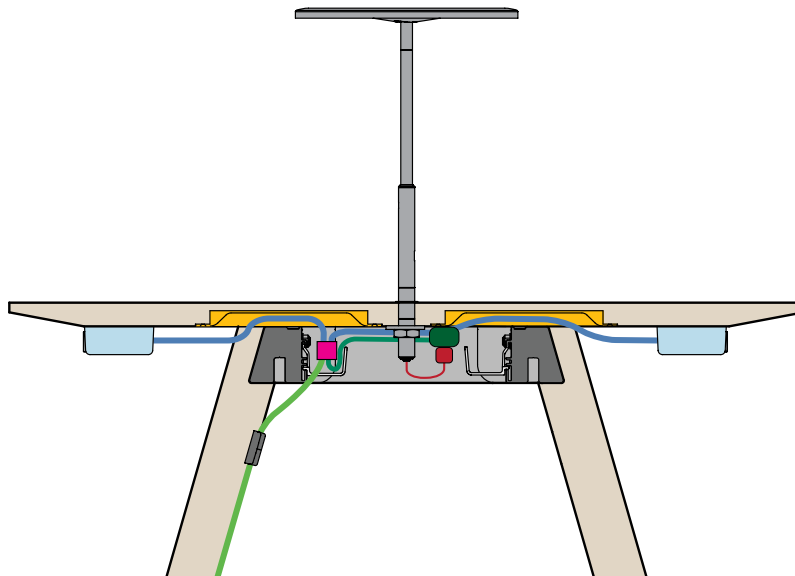

**Larkin Light shown with optional Under Mount Power Option**  
Under mount to be specified separately



**Larkin Light - Only**

Grommet kits and locations codes for veneer and laminate tops.  
Kits include Larkin light and necessary components based on table length and power option.  
Grommet kits ship separately from tops.

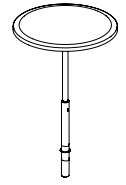

sku	descriptions	price
LL1	<b>72" - 108" Tables      36" - 60" Wide</b>	\$ 2100
LL2	<b>72" - 120" Tables      36" - 60" Wide</b>	4200
LL3	<b>90" - 144" Tables      36" - 60" Wide</b>	6100

specification codes example: LKS-SKU-CRD-144

series	sku	power option	table length
Larkin		CRD corded	072 114
			078 120
			084 126
			090 132
			096 138
			102 144
			108

**Important:**  
Specify the length of the table that your configuration is to go on, this will insure the proper length of wiring is provided in the kit.

faceplate finish code example: WH

faceplate finish
GR graphite
WH white

**Larkin Light - Only**

Grommet kits and locations codes for veneer and laminate tops.  
Kits include Larkin light and necessary components based on table length and power option.  
Grommet kits ship separately from tops.

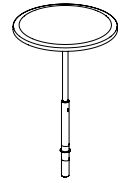

sku	descriptions	price
LL4	<b>126" - 240" Tables      36" - 60" Wide</b>	\$ 7800
LL5	<b>144" - 240" Tables      36" - 60" Wide</b>	9600
LL6	<b>228" - 240" Tables      36" - 60" Wide</b>	11500

**specification codes example: LKS-SKU-CRD-240**

series	sku	power option	table length
Larkin		CRD corded	126 168 210
			132 174 216
			138 180 222
			144 186 228
			150 192 234
			156 198 240
			162 204

**Important:**  
Specify the length of the table that your configuration is to go on, this will insure the proper length of wiring is provided in the kit.

**faceplate finish code example: WH**

faceplate finish
GR graphite
WH white

### Larkin Power with Light Grommet and Larkin Light

Grommet kits and locations codes for veneer and laminates tops.  
 Kits include Larkin power with light grommets, Larkin light and all jumpers and necessary components based on table length and power option.  
 Grommet kits ship separately from tops.

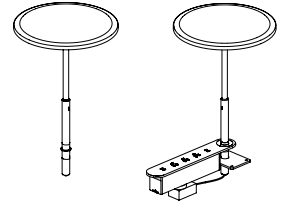

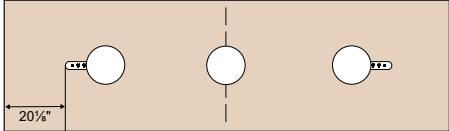
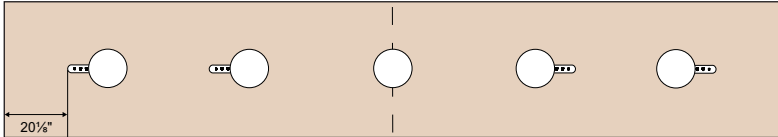
sku	descriptions	price
<b>LP3</b>	<b>120" - 240" Tables      36" - 60" Wide</b> Includes (2) Larkin power with light grommets and (1) Larkin light 	\$ 9400
<b>LP5</b>	<b>144" - 240" Tables      36" - 60" Wide</b> Includes (4) Larkin power with light grommets and (1) Larkin light 	15900

specification codes example: LKS-SKU-CRD-240

series	sku	power option	table length		
Larkin		CRD corded	120	162	234
			126	168	210
			132	174	216
			138	180	222
			144	186	228
			150	192	234
			156	198	240

**Important:**  
 Specify the length of the table that your configuration is to go on, this will insure the proper length of wiring is provided in the kit.

faceplate finish code example: WH

faceplate finish	
GR	graphite
WH	white

### Under Mount Power



Larkin offers a proprietary under mount power solution allowing quick and easy daisy chaining of modules together. A maximum of (6) under mount power modules can be connected on one power infeed.

The under mount power modules are available in (1) configuration: (1) receptacle, (1) 2 amp USB-A port and (1) 2 amp USB-C port. End user installation will be required per individual SKU. Each SKU includes a separate power infeed with a 10' grounded plug to connect to the power source. See installation instructions for installing.

The Larkin table collection provides suggested locations for 2 - 6 under mount power modules. See following pages for details on recommended configurations. Under mount power is certified to UL STD 962 A CSA STD 22.2 No. 21.

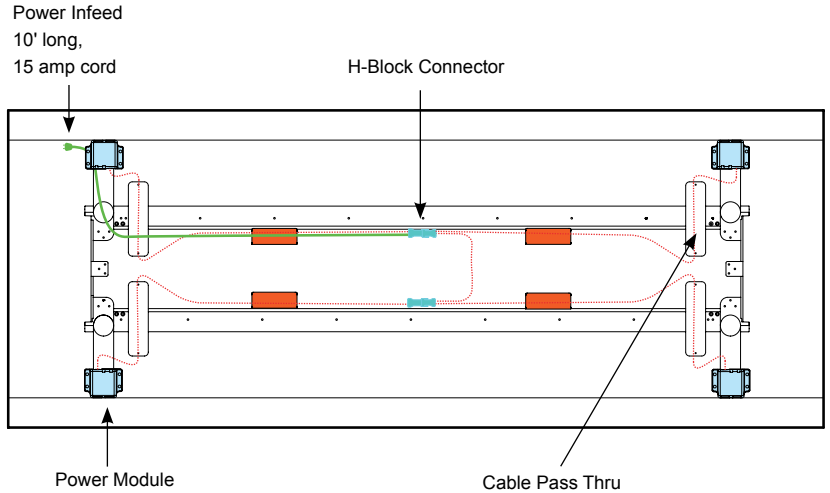

**Note:** Bernhardt Design provides recommendations for installation locations on the following pages. Further installation instructions are included with each power unit. End user installation will be required per individual sku. Power is specified separately.

#### Power Module Matte Black Finish

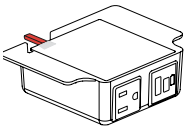

power + usb-a + usb-c  
(1) 15 amp receptacle, 120 v 60 Hz.  
(1) 2 amp USB-A port, 10 watt  
(1) 2 amp USB-C port, 20 watt  
36" pattern whip or  
braided cotton 10' cord,  
grounded plug, UL 962 listed

#### Jumper included in kit (if required)

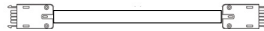

Jumper is determined by the length of the top specified and is included in the grommet code kit

#### H-Block Connector Grey Finish included in kit

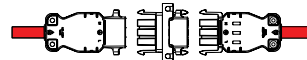

Not used with corded or hardwired modules

#### Power Infeed included in kit

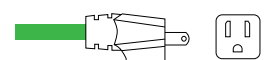

10' Grounded, 15 amp plug,  
Braided Cord

### Under Mount Management

The following illustration shows a section view of the Larkin table with under mount power.

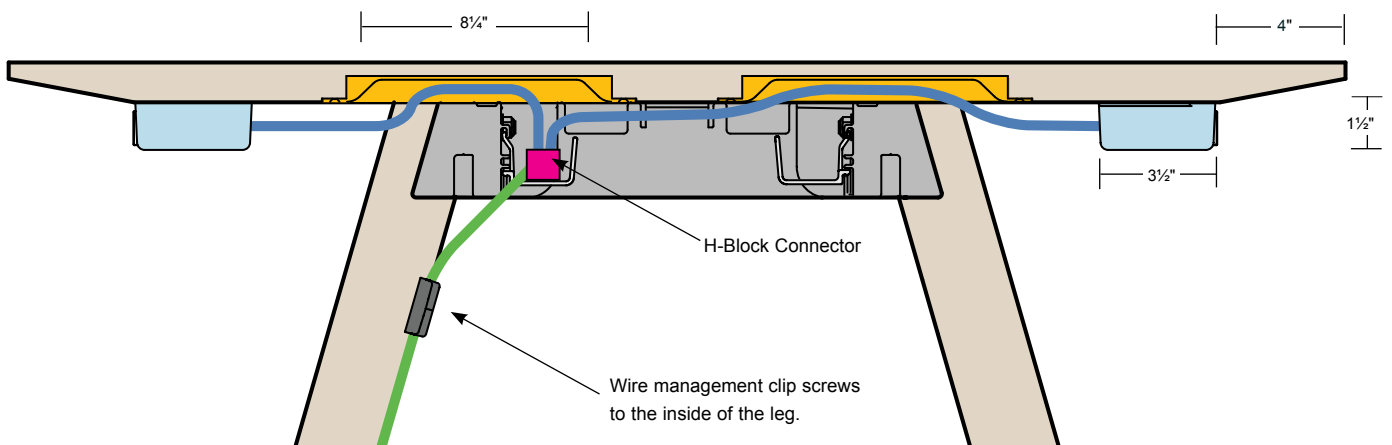

### Under Mount Power Placement Kits

Under Mount power options by Bernhardt Design are offered as a kit which includes all modules and wire management needed to bring power from the floor to the user. The number of modules and lengths of wire management are determined by the table lengths selected. Your kit will come complete with all necessary parts to install in the field.

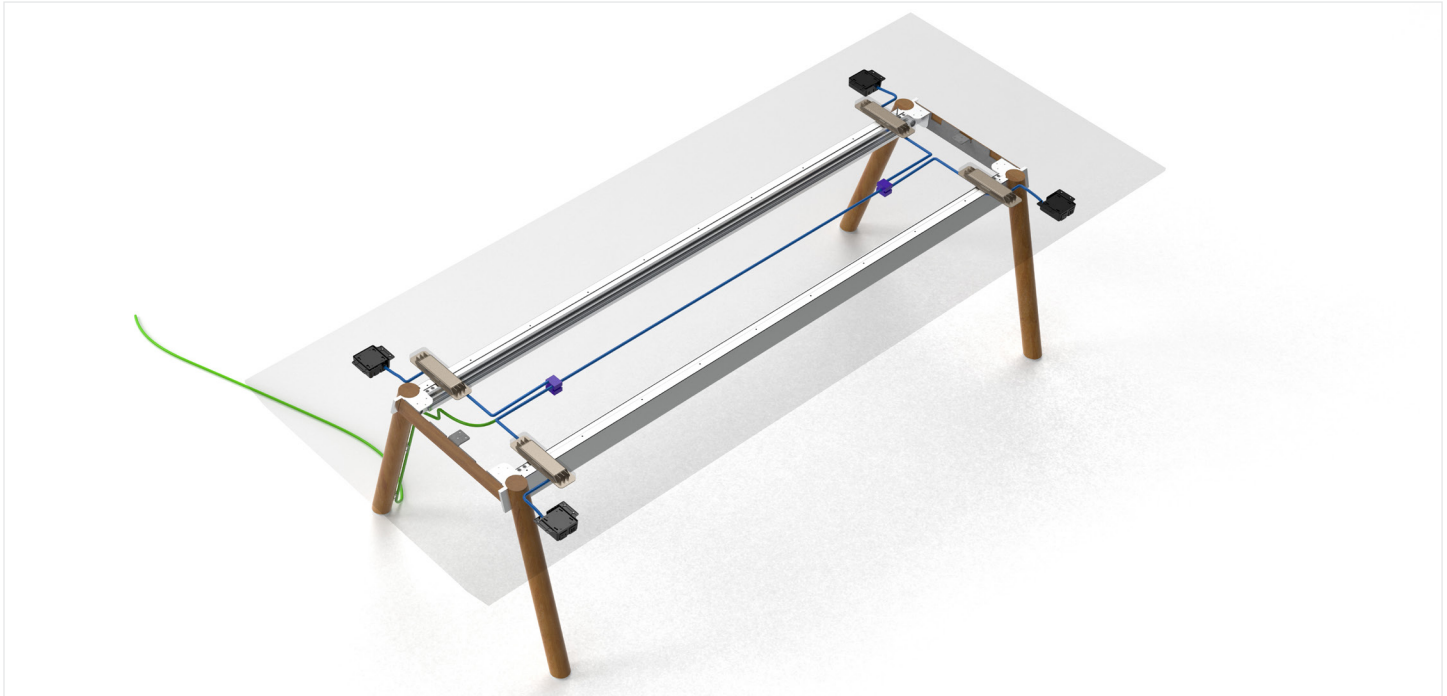

#### Ordering Under Mount Power

- Select the grommet code that best suits your requirements
- Select the power style

The Grommet Kit will ship separately and will be installed in the field.

#### 60" - 150" Table

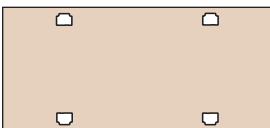

#### Ordering Example:

60" x 150" Table Top  
Oak veneer, 870 finish  
LU4 Grommet Code

#### 126 - 222" Table

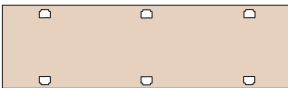

#### Ordering Example:

126" x 222" Table Top  
Walnut veneer, 872 finish  
LU6 Grommet Code

#### Under Mount Dimensions for 60" - 90" Tables

Top Depth	Distance to Grommet
36"	10¾"
42"	10¾"
48"	10¾"
54"	10¾"
60"	10¾"

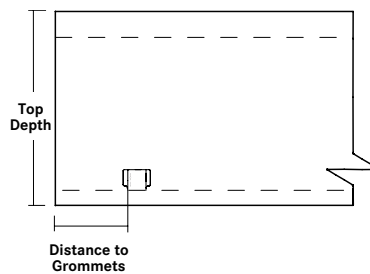

#### Under Mount Dimensions for 96" - 240" Tables

Top Depth	Distance to Grommet
36"	13¾"
42"	13¾"
48"	13¾"
54"	13¾"
60"	13¾"

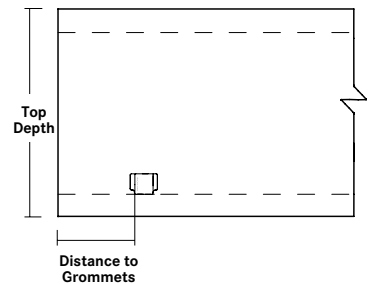

specification codes example: ACS-SKU-PU060

series	sku	power style	table length
A   C   S   -	-	PU power + usb + usb-c	060 108 156 204
			066 114 162 210
			072 120 168 216
			078 126 174 222
			084 132 180 228
			090 138 186 234
			096 144 192 240
			102 150 198

#### Important:

Specify the length of the table that your configuration is to go on, this will insure the proper length of wiring is provided in the kit.



Under mount power kits are specified and sold separately. Each kit lists the table top sizes compatible with the number of power units shown.

All kits include a 10' corded infeed with grounded and fused plug.

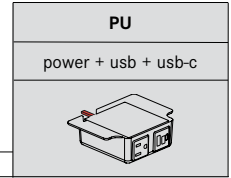

# of Kits sku specifications

8 Module Kits

LU8 228" - 240" Tables 48" - 60" Wide Tables

\$ 5576

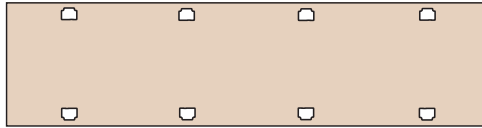

10 Module Kits

LU10 228" - 240" Tables 48" - 60" Wide Tables

7350

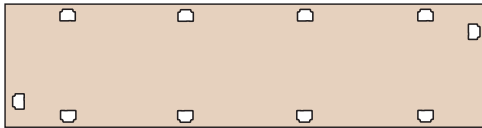

specification codes example: ACS-SKU-PU0240

series	sku	power style	table length
A   C   S   -	-	PU power + usb + usb-c	228 234 240
P   U	-		

**Important:**  
Specify the length of the table that your configuration is to go on, this will insure the proper length of wiring is provided in the kit.

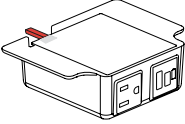
description	sku	w	d	h	specifications	price
 <p><b>power module</b></p> <p>(1) 15 amp receptacle, 120 v 60 Hz.                  (1) 2 amp USB-A port, 10 watt                  (1) 2 amp USB-C port, 20 watt                  9' cord grounded plug                  UL 962 listed</p>	UPM	4¾	3½	1½		551

specification codes example: ACS-SKU

series	sku
accessories A   C   S   -	



## Mediatrac1™

The Larkin collection introduces new structural rails that work in conjunction with Mediatrac1.

Mediatrac1 is a simplified system for routing power and data to the conference table worksurface while managing wires and auxiliary equipment.

Mediatrac1 grommet system provides power and (16) different options for Extron data configurations. Grommets are available in (5) different sizes ranging from an 8" x 4" single door unit to a 48" x 8" (4) door unit. All units have brushed aluminum trim with options for aluminum, laminate, or veneer lids in corded, hardwired or 4-Trac system power infeed.

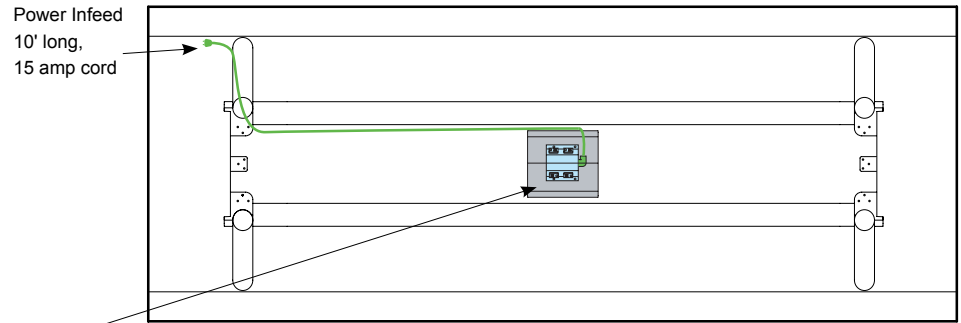

**Note:** Bernhardt Design provides recommendations for installation locations. End user installation will be required per individual sku. Power is specified separately.

Mediatrac1™ offers power options that utilize the electrical 4-Trac Power System, allowing for easy installation and reconfiguration capabilities. 4-Trac snaps together easily underneath the worksurface using whips from each power module and the integral 4-Trac jumpers specified for use with each particular Mediatrac1 grommet size. The grommet layout and wiring scheme is specified specifically for each top size, requiring the customer to separately purchase only the required infeeds and jumpers.

Mediatrac1 is certified to UL STD 962A, UL STD 1363, CSA STD 22.2 No. 308-14. 4-Trac is certified to UL STD 183 CSA STD 22.2 No. 203.1-14.

## Mediatrac1 Options

### 8" Single Door Mediatrac™ Grommet

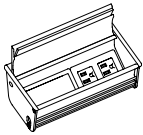

2 grounded outlets, 1 exit plug, accepts 2 Extron single space AAP's, AAP modules specified separately, brushed aluminum frame

### 8" Double Door Mediatrac™ Grommet

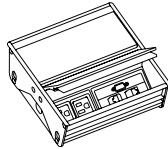

4 grounded outlets, 1 exit plug, accepts 4 Extron single space AAP's, AAP modules specified separately, brushed aluminum frame

### 24" Double Door Mediatrac™ Grommet

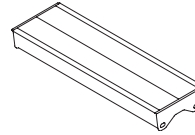

8 grounded outlets, 2 exit plugs, accepts 8 Extron single space AAP's, AAP modules specified separately, brushed aluminum frame

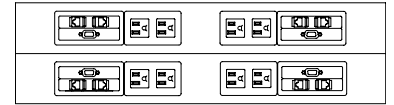

## Mediatrac1 Grommet Kits (Includes the following)

### Power Module

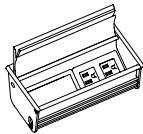

Number and configuration of grommet modules determined by the grommet code

### Jumper (if required)



Jumper are determined by the length of the top specified

### H-Block Connector Grey Finish



Not used with cored or hardwired modules

### Power Infeed Options

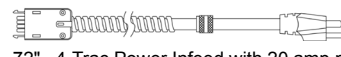

72" 4-Trac Power Infeed with 20 amp plug



20 amp receptacle 4-trac Only



72" 4-Trac Power Infeed with Hardwired Conduit

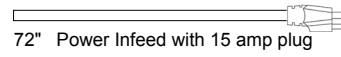

72" Power Infeed with 15 amp plug



15 amp receptacle

## Mediatrac1 Features

Mediatrac1 is available in a range of sizes up to 72" which can be used in longer spans. Mediatrac1 utilizes the plug and play power system and offers 1" diameter round grommets that are available for speakerphone wire management. Single door grommets have (2) receptacles and (2) AAP single plates while double door grommets have (4) receptacles and (4) AAP single plates. Mediatrac1 is UL listed.

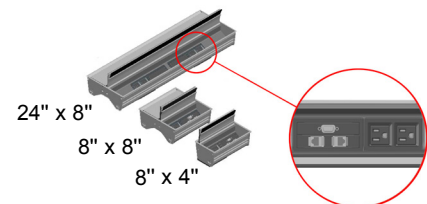
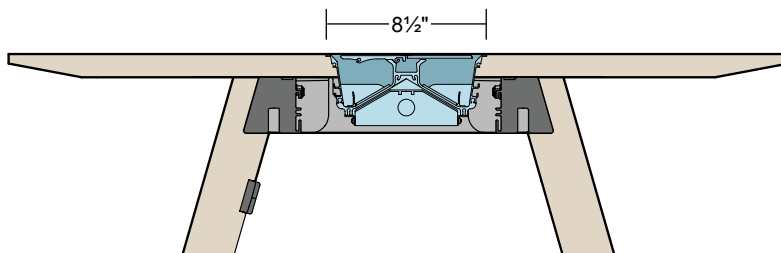

Power/Data locations in Mediatrac1 grommets

### Mediatrac1™ 4-Trac Power System

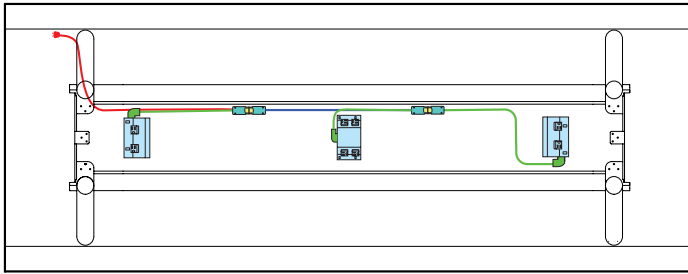

Mediatrac1 is available in our 4-Trac Power System, allowing for easy installation and reconfiguration capabilities.

4-Trac snaps together easily underneath the worksurface using whips from each power module and the integral 4-Trac jumpers specified for use with each particular Mediatrac1 grommet size. **The grommet layout and wiring scheme is specified specifically for each top size and is included with each kit.**

Each power transition is accommodated by an H-Block, which gives the ability to snap together four power leads. Using the provided documentation to facilitate installation, powering the Mediatrac1 system is as easy as snapping together connectors.

Infeeds are available in both hardwired and corded version in a 72" length. The plug version for the Mediatrac1 power system is 20 amps and will require plugging into a 20 amp outlet to comply with electrical codes.

#### Mediatrac1 Grommets Using Electrical 4-Trac Power System

- Power Infeed
- Power Module Whip
- Modular Connector
- Jumper
- Power Drop
- Power Module
- H-Block



4-Trac Infeed snaps into an H-Block connected to a Mediatrac1 power module with a 18" modular end.



72" 4-Trac Power Infeed with Hardwired Conduit

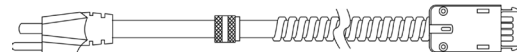

72" 4-Trac Power Infeed with 20 amp Plug



20 amp Receptacle

Illustrations showing electrical 4-Trac power infeed end options – hardwired conduit and 20 amp corded plug. Both are available in 72" lengths. 20 amp receptacle must be used with the plug.

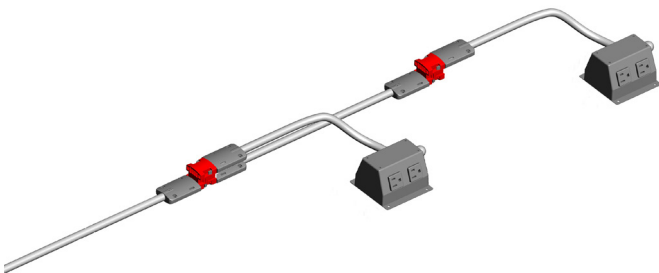

4-Trac H-Block connects up to (4) Jumpers and Power Modules.

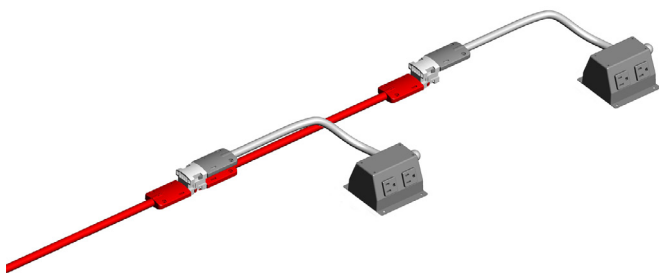

4-Trac Jumpers used in conjunction with the H-Block to wire the system.

### Mediatrac 1™ Grommet Placement Kits

Mediatrac 1™ power options by Bernhardt Design are offered as a grommet kit which includes all grommets, jumpers and necessary components needed to bring power from the floor to the user. The number of grommets and lengths of jumpers are determined by the lengths and power options selected. Your kit will come complete with all necessary parts to install in the field.

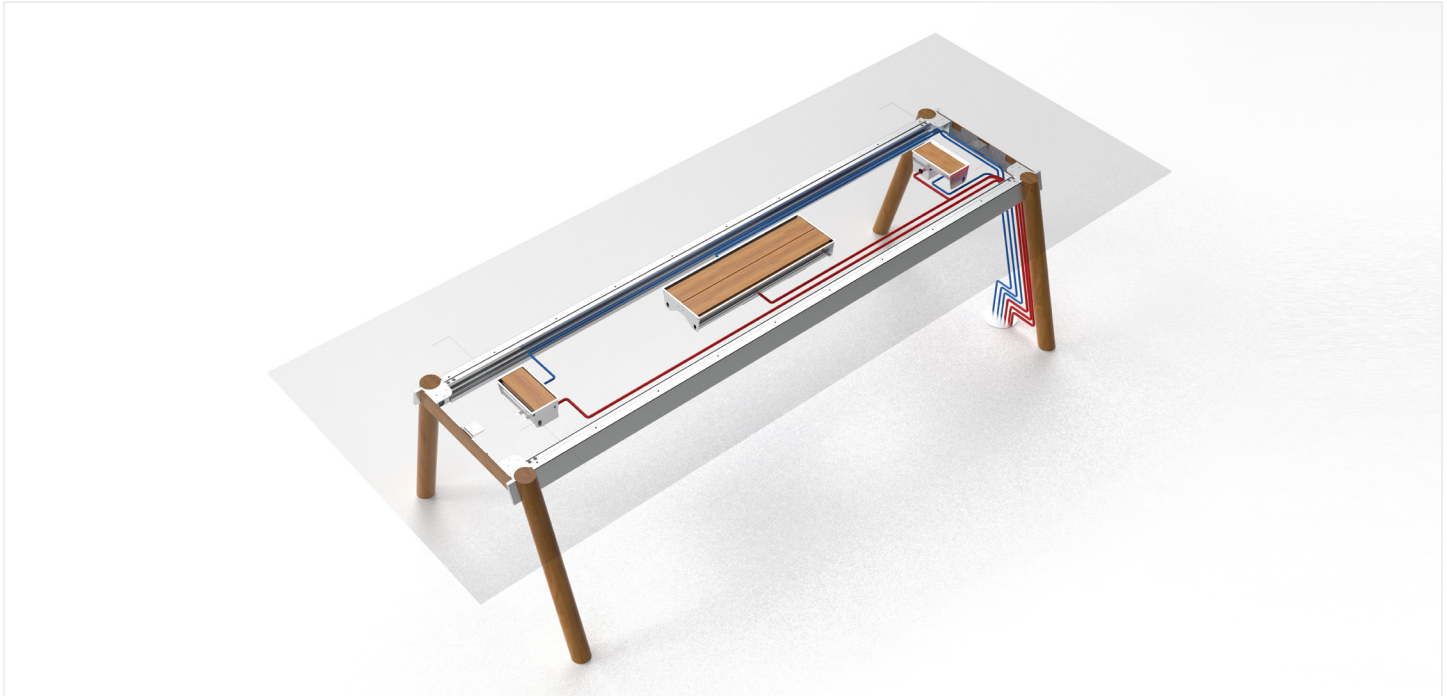

### Ordering Mediatrac 1 Grommets

- Determine the amount of power and data needed
- Select the grommet code that best suits your requirements
- Select the type of power infeed you need
- Select the length of table that this is to be used on  
*(make sure that this grommet code matches the code used when ordering your top)*
- Select the grommet trim/frame finish
- Select the lid/door material
- Select the lid/door finish

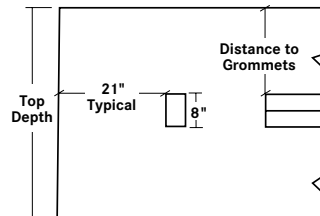

Top Depth	Distance to Grommet
42"	17"
48"	20"
54"	23"
60"	26"

The Grommet Kit will ship separately and will be installed in the **field**.

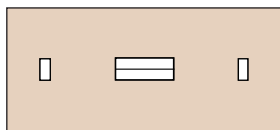

#### Ordering Example:

**120" x 54" Table Top**  
**Oak Veneer, 870 Finish**  
**M08 Grommet Code with 4trac Corded Power**  
**Polished Aluminum Frame, Oak Lid, 870 Finish**

specification codes example: **MGS-SKU-CRD120**

series	sku	power option	table length
top		<b>CRD</b> corded	048 102 150 198
		<b>HWD</b> hardwired	054 108 156 204
		<b>4TC</b> four trac corded	060 114 162 204
		<b>4TH</b> four trac hardwired	066 120 168 216
			072 126 174 222
			078 132 180 228
			084 138 186 234
			090 144 192 240
			096

#### Important:

Specify the length of the table that your configuration is to go on, this will insure the proper length of wiring is provided in the kit.

material + finish code example: **BA WLT 870**

frame finish	lid material	lid finish
<b>BA</b> brushed aluminum	<b>ALM</b> aluminum	see finish pages
<b>upcharge will apply</b>	<b>PLL</b> solid laminate	
see powder coat finishes	<b>WGL</b> woodgrain laminate	
	<b>OAK</b> oak	
	<b>WLT</b> walnut	

Mediatrac 1 grommet kits and locations codes for veneer, laminates and solid surface tops.  
Kits include all jumpers and necessary components based on table length and power option.  
Grommet kits ship separately from tops.

Mediatrac not available on 36" wide tables.

Specify table length, power style, lid material and frame finish below.

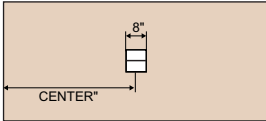
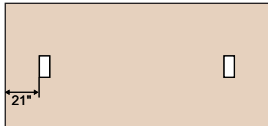
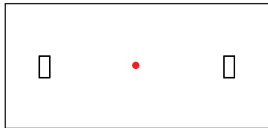
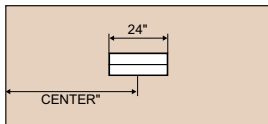
sku	specifications	lid material		
		ALM aluminum	PLL solid laminate WGL woodgrain laminate	OAK oak WLT walnut
<b>M03</b>	<b>60" - 240" Tables</b> <b>42" - 60" Wide Tables</b>  (1) 8" double door mediatrac grommet 	\$ 1999	\$ 2250	\$ 3125
<b>M04</b>	<b>60" - 240" Tables</b> <b>42" - 60" Wide Tables</b>  (2) 8" single door mediatrac grommets 	2749	2999	5062
<b>P04</b>	<b>60" - 240" Tables</b> <b>42" - 60" Wide Tables</b>  same information as M04 (1) 1" dia. grommet for microphone 	2875	3125	5186
<b>M06</b>	<b>60" - 240" Tables</b> <b>42" - 60" Wide Tables</b>  (1) 24" double door mediatrac grommet 	2813	3063	4186

specification codes example: MGS-SKU-CRD120

series	sku	power option	table length
top		CRD corded	060 108 156 204
		HWD hardwired	066 114 162 210
		4TC four trac corded	072 120 168 216
		4TH four trac hardwired	078 126 174 222
			084 132 180 228
			090 138 186 234
			096 144 192 240
			102 150 198

**Important:**  
Specify the length of the table that your configuration is to go on, this will insure the proper length of wiring is provided in the kit.

material + finish code example: BA WLT 870

frame finish	lid material	lid finish
BA brushed aluminum	ALM aluminum	see finish pages
powder coat upcharge \$75 see powder coat finishes	PLL solid laminate	
	WGL woodgrain laminate	
	OAK oak	
	WLT walnut	

Mediatrac 1 grommet kits and locations codes for veneer, laminates and solid surface tops.  
Kits include all jumpers and necessary components based on table length and power option.  
Grommet kits ship separately from tops.

Mediatrac not available on 36" wide tables.

Specify table length, power style, lid material and frame finish below.

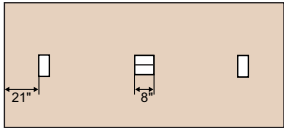
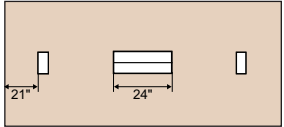
sku	specifications	lid material		
		ALM aluminum	PLL solid laminate WGL woodgrain laminate	OAK oak WLT walnut
<b>M05</b>	<b>72" - 240" Tables      42" - 60" Wide Tables</b>  (2) 8" double door mediatrac grommets 	\$ 3624	\$ 3874	\$ 5997
<b>M07</b>	<b>84" - 240" Tables      42" - 60" Wide Tables</b>  (1) 8" double door mediatrac grommet (2) 8" single door mediatrac grommets 	4374	4874	7872
<b>M08</b>	<b>84" - 240" Tables      42" - 60" Wide Tables</b>  (1) 24" double door mediatrac grommet (2) 8" single door mediatrac grommets 	5124	5623	8684

specification codes example: MGS-SKU-CRD120

series	sku	power option	table length
top		CRD corded	072 120 162 201
		HWD hardwired	078 126 168 210
		4TC four trac corded	084 132 174 216
		4TH four trac hardwired	090 138 180 222
			096 144 186 228
			102 150 192 234
			108 156 198 240
			114

**Important:**

Specify the length of the table that your configuration is to go on, this will insure the proper length of wiring is provided in the kit.

material + finish code example: BA WLT 870

frame finish	lid material	lid finish
BA brushed aluminum	ALM aluminum	see finish pages
powder coat upcharge \$150 see powder coat finishes	PLL solid laminate	
	WGL woodgrain laminate	
	OAK oak	
	WLT walnut	

Mediatrac 1 grommet kits and locations codes for veneer, laminates and solid surface tops.  
Kits include all jumpers and necessary components based on table length and power option.  
Grommet kits ship separately from tops.

Mediatrac not available on 36" wide tables.

Specify table length, power style, lid material and frame finish below.

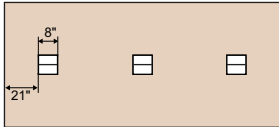
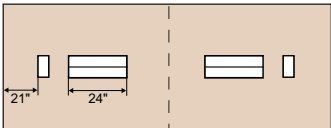
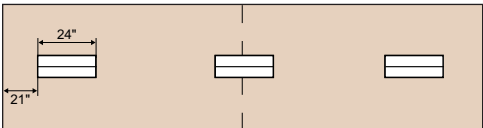
sku	specifications	lid material		
		ALM aluminum	PLL solid laminate WGL woodgrain laminate	OAK oak WLT walnut
<b>M10</b>	<b>96" - 240" Tables      42" - 60" Wide Tables</b>  (3) 8" double door mediatrac grommets 	\$ 5436	\$ 5936	\$ 8995
<b>M15</b>	<b>132" - 240" Tables      42" - 60" Wide Tables</b>  (2) 8" single door mediatrac grommets (2) 24" double door mediatrac grommets 	7122	7746	11744
<b>M30</b>	<b>156" - 240" Tables      42" - 60" Wide Tables</b>  (3) 24" double door mediatrac grommets Two power infeeds will be arranged for a power drop located at the center of the table. Complies with UL standards. 	7622	8371	11619

specification codes example: MGS-SKU-CRD120

series	sku	power option	table length
top		CRD corded	096 138 174 210
		HWD hardwired	102 144 180 216
		4TC four trac corded	108 150 186 222
		4TH four trac hardwired	114 156 192 228
			120 162 198 234
			126 168 204 240
			132

**Important:**  
Specify the length of the table that your configuration is to go on, this will insure the proper length of wiring is provided in the kit.

material + finish code example: BA WLT 870

frame finish	lid material	lid finish
BA brushed aluminum	ALM aluminum	see finish pages
powder coat upcharge \$225 see powder coat finishes	PLL solid laminate	
	WGL woodgrain laminate	
	OAK oak	
	WLT walnut	

Mediatrac 1 grommet kits and locations codes for veneer, laminates and solid surface tops.  
Kits include all jumpers and necessary components based on table length and power option.  
Grommet kits ship separately from tops.

Mediatrac not available on 36" wide tables.

Specify table length, power style, lid material and frame finish below.

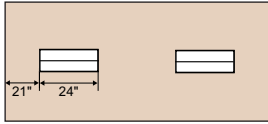
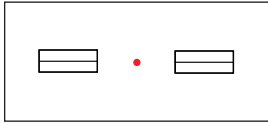
sku	specifications	lid material		
		ALM aluminum	PLL solid laminate WGL woodgrain laminate	OAK oak WLT walnut
<b>M12</b>	<b>108" - 240" Tables      42" - 60" Wide Tables</b> (2) 24" double door mediatrac grommets 	\$ 5636	\$ 6135	\$ 7810
<b>P12</b>	<b>108" - 240" Tables      42" - 60" Wide Tables</b> same information as M12 (1) 1" dia. grommet for microphone 	5762	6261	7935

specification codes example: MGS-SKU-CRD120

series	sku	power option	table length
top		CRD corded	108 144 180 216
		HWD hardwired	114 150 186 222
		4TC four trac corded	120 156 192 228
		4TH four trac hardwired	126 162 198 234
			132 168 204 240
			138 174 210

**Important:**  
Specify the length of the table that your configuration is to go on, this will insure the proper length of wiring is provided in the kit.





material + finish code example: BA WLT 870

frame finish	lid material	lid finish
BA brushed aluminum	ALM aluminum	see finish pages
powder coat upcharge \$150 see powder coat finishes	PLL solid laminate	
	WGL woodgrain laminate	
	OAK oak	
	WLT walnut	



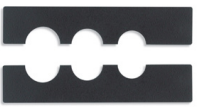
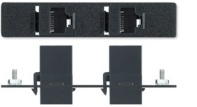







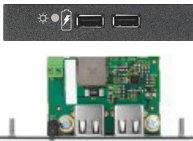

	description	sku	w	d	h	price
	<b>blank plate</b> Extron® AAP blank plate with black powder coat finish single space insert	VGG	3½	-	5⁄8	161
	<b>cable pass-through module</b> Extron® AAP single space, cable pass-through plates sold as a set of (2) black powder coat finish specify for use with VMW cable sling	VGY	3½	-	1¾	459
	<b>phone/data module</b> Extron® AAP two RJ-45 pass-through barrels CAT 5e single space insert	VGD	3½	-	5⁄8	346
	<b>phone/data module</b> Extron® AAP one RJ-45 female to punch down block leviton CAT6 data single space insert	VGK	3½	-	5⁄8	277
	<b>phone/data module</b> Extron® AAP two RJ-45 female to punch down block leviton CAT6 data single space insert	VGP	3½	-	5⁄8	384
	<b>phone/data module</b> Extron® AAP two RJ-45 female to punch down block AMP CAT6 data single space insert	VGL	3½	-	5⁄8	384

series	sku
accessories	
A   C   S   -	

description	sku	w	d	h	price
 <p><b>phone/data module</b></p> <p>Extron® AAP two RJ-45 female to punch down block higher than CAT6 data type connectors systemax MGS500 backward compatible double space insert</p>	VGQ	3½	-	1¾	\$ 523
 <p><b>computer/audio/video module</b></p> <p>Extron® AAP HDMI female to HDMI female on 10" pigtail single space insert</p>	VG3	3½	-	5⁄8	384
 <p><b>control/computer module</b></p> <p>Extron® AAP two USB A female to female barrels single space insert</p>	VGR	3½	-	5⁄8	384
 <p><b>power plate charging module</b></p> <p>type 5 VDC USB C power outlet 3 A/45 watts type 5 VDC USB A power outlet 2.1A/10.5 watts of power for charging mobile devices, single space insert</p>	VG9	3½	-	5⁄8	1316
 <p><b>usb charging module</b></p> <p>Extron® AAP Power Plate charging module 2 5 VCD USB power outlets 2.1 A / 10.5 watts of power for charging mobile devices single space insert</p>	VGU	3½	-	5⁄8	746
 <p><b>computer/audio/video module</b></p> <p>Extron® SuperPlate 110 - HDMI/DisplayPort/Stereo Audio/USB HDMI: female to female, 10" (25 cm) pigtail DisplayPort: female to female, 10" (25 cm) pigtail Stereo/Audio: 3.5 mm mini jack to captive screw, 10" (25 cm) pigtail USB A: female to female, 10" (25 cm) pigtail double space insert</p>	VG6	3½	-	1¾	610

series	sku
accessories	
A   C   S   -	

**Prices and Specifications**

Prices and specifications are subject to change without notice. All prices quoted will be FOB our factories. If applicable, sales tax will be based on ship-to destination.

Bernhardt Design reserves the right to make changes in dimensions, construction, price lists, or product literature without prior notice.

All measurements and weights are approximate and subject to change without notice.

**Order Entry**

All orders are subject to final acceptance by Bernhardt Design in Lenoir, NC. Receipt of our acknowledgment indicates acceptance of your order subject to the terms set forth on the acknowledgment.

Bernhardt Design attempts to clarify all purchase orders. However, in the event the price list number and description on the purchase order differ, the price list number will prevail.

**Changes/Cancellation**

All orders in production are considered firm orders and are not subject to changes or cancellation.

**Shipping**

Bernhardt Design will ship in accordance with customer instructions whenever possible. For convenience, Bernhardt Design offers a guaranteed freight program (GFP). Bernhardt Design will exercise our best judgment in selecting a carrier under our GFP. When selecting a carrier, Bernhardt Design will make our best effort to meet requested delivery dates.

Transportation lead-times and delays including equipment problems, weather, general traffic, traffic accidents, customer warehouse space, labor disputes, customer changes, etc., that occur on a carrier will not be the responsibility of Bernhardt Design. Furthermore, Bernhardt Design will not be responsible for additional costs incurred due to aforementioned delays.

For customers who decline our GFP, Bernhardt Design will stage orders for pick up at 1% of the list price, or \$75 minimum.

Customer orders in production will be shipped as scheduled and will not be held. Bernhardt Design reserves the right to make partial shipments on any order, unless notified otherwise by the customer.

High quality cartoning meeting trucking and railroad specifications is standard at no extra charge. Some items may be blanket wrapped for shipment.

**Freight Damage and Claims**

Bernhardt Design is not liable for any damages to products that occur during transit or storage. The carrier assumes all responsibility upon acceptance of product. It is the customer's responsibility to inspect products upon receipt and file any claims with the carrier. No product should be refused. If products are received damaged, a written exception should be made on the bill of lading and an immediate inspection be requested of the carrier.

Concealed damage must be reported to the carrier within 10 business days from date of delivery. Failure to make claims shall constitute acceptance of the products and waiver any claims of defects, errors or shortages.

In the event delivery is made on a Bernhardt Design truck, the products should be carefully inspected for transit damage. If contents are damaged, the driver should be notified to call his dispatcher for immediate disposition.

Concealed damage must be reported within 10 business days from date of delivery and product/package held for inspection by a Bernhardt Design representative. Replacements for product damaged in shipment or storage will be manufactured upon receipt of a purchase order.

**Returns**

No merchandise may be returned to Bernhardt Design without written consent in the form of a Return Authorization from our Quality Assurance Department stating why item is being returned and how item will be shipped.

Unauthorized returns will be automatically refused by our receiving department as well as returns not in accordance with Bernhardt Design shipping instructions. Liability for defective merchandise shall be limited to the replacement or repair of that merchandise, and Bernhardt Design shall not be liable for other damages or losses.

**Terms and Credit**

Pricing and terms of sale apply to orders accepted by Bernhardt Design, and no terms, stipulations, or conditions contained in the dealer's submitted purchase orders shall have any force or effect. Bernhardt Design requires a completed and signed credit application from every dealer. Bernhardt Design also requires dealers to provide a Blanket Certificate of Resale/Use containing valid sales tax exemption number(s) for their respective state(s).

If credit has been approved, the standard terms for all Bernhardt Design products are Net 30 from the invoice date. In certain instances, as an additional condition of order acceptance, buyer may be required to provide a deposit at time of order and/or remit the balance before shipment is released. If credit has not been approved, a 100% prepayment, including any freight charges, is required prior to production.

Acceptable forms of payment include a certified check or electronic bank transfer. For information on where to send check/electronic bank information contact our Financial Services Department. If a dealer or company check is submitted, three (3) weeks should be allowed for the clearance of the check. If electronic bank transfer is submitted, one (1) week should be allowed for the clearance of the electronic bank transfer. The order is subject to cancellation if payment in full is not received within three (3) weeks from the acknowledgment date.

The dealer may not make deductions for advertising, promotions, quality problems, freight, or any other reason without prior authorization by Bernhardt Design. Such a deduction could result in the curtailment or suspension of further shipments until the matter is resolved. Delinquency notices are generated and mailed periodically. Service charges of 18% per annum will be added to each past-due transaction. Unpaid service charges

will be accrued and invoiced on a periodic basis. Past-due notices may result in orders being held until the situation is resolved. This credit hold could prevent orders from being placed into production or shipped. Orders not in production that are placed on credit hold for three (3) weeks will be subject to cancellation.

Severe past-due situations may result in the employment of a collection agency or other collection litigation. If any collection activity is necessary regarding a dealer account, the dealer will be responsible for the payment of any and all attorney and collection agency fees.

A slow payment history may result in reducing or eliminating an open line of credit. At the discretion of Bernhardt Design, amounts owed by a dealer to Bernhardt Design arising from any transaction or dealings between the dealer and Bernhardt Design may be offset against any amounts owed to the dealer by Bernhardt Design.

### Warranty

Bernhardt Design will repair or replace, at its discretion, any product or part thereof which fails as the result of defects in material and workmanship, under single shift use and normal care for five years from date of shipment. This warranty shall apply only to the original purchaser.

This warranty does not cover normal wear and tear, misuse or abuse of product, dramatic temperature changes, exposure to unusual conditions or damages incurred by contact with seating products, tables, desks or other surfaces. Natural color changes, variations or movements in lumber or veneer products, exposure to extreme temperature changes and direct sunlight may cause color changes and/or surface damage. These are circumstances beyond the control of Bernhardt Design and are not warranty issues. Repair or replacement of discontinued product will be at the discretion of Bernhardt Design.

This warranty is the customer's exclusive remedy for product defect and does not apply to damage caused by a freight carrier, dealer, installer, user modification, attachments to a product, or any third party. Bernhardt Design has the exclusive right to make the final determination of product misuse or abuse. Except as stated above, Bernhardt Design makes no express or implied warranties as to any product, and in particular, makes no warranty of merchantability or of fitness for any particular purpose. Bernhardt Design shall not be liable for any consequential or incidental damages or for commercial loss arising from any product defect.

### Operational Parts Warranty

Drawer glides, drawer boxes, drawer pulls, and lock mechanisms have a Life-Time Warranty for original purchaser. Power and communication components are warranted for one year.

### Parts Order

Bernhardt Design parts have a \$25 net minimum per order. This does not include freight costs.

### Custom Design

Bernhardt Design may alter products to meet specific needs. Contact your local sales representative when a custom design is needed. Custom designs,

**if approved**, require minimum quantities, additional leadtime and upcharges. A custom job number, available from your Bernhardt Design sales representative, must be submitted with purchase orders.

Orders combining custom design with standard product cannot be scheduled for production until custom items are approved. Custom design orders are not subject to revision or cancellation after acknowledgment.

### Wood Finishes

Bernhardt Design tables are available in finishes that are compatible with credenzas and seating finishes. However, finishes on tables may vary slightly from those on seating due to the natural characteristics of the wood. No absolute match is implied or guaranteed.

### Light Finishes

Bernhardt Design offers lighter finishes on certain veneers and solid woods. When specifying light finishes the natural characteristics of the wood will be visible and color will vary.

Natural characteristics include the natural discolorations of the wood substance and color variations in glued up stock. These natural characteristics are not considered defects by Bernhardt Design, and therefore merchandise will not be replaced.

### Special Finishes

Special finishes, made to customer specifications and subject to factory approval, may be available at a **10% net upcharge with a \$500 net minimum**.

Additional leadtime may be required for special finish items. Special finish orders will not be acknowledged until the special finish sample is approved in writing and received by Bernhardt Design Customer Service. Special finish orders are not subject to revision or cancellation after acknowledgment.

### Installation and Maintenance

All freestanding tables and credenzas are equipped with leveling devices. Local floor conditions vary, and it is always necessary to properly adjust leveling devices. Proper leveling is essential to the alignment and function of doors and drawers.

Improperly leveled units result in misaligned doors and drawers and may impair locking mechanisms or other functional hardware.

After the initial installation of credenzas, it may be necessary to readjust and align the units to compensate for settling. This should be expected as a matter of routine maintenance and follow-up to assure proper case function.

Proper installation of Bernhardt Design tables and credenzas is the responsibility of the dealer. Improperly installed units can result in permanent damage to case components. Damage due to improperly installed furniture not covered under product warranty.

Orders combining custom design with standard product cannot be scheduled for production until custom items are approved. Custom design orders are not subject to revision or cancellation after acknowledgment.

**Care and Cleaning**

Finished wood surfaces should be cleaned with a soft damp cloth, wiping in the direction of the grain. Furniture should be buffed dry immediately with a soft cloth.

**Design and Patent Rights**

All of the products shown in Bernhardt Design catalogs and described in Bernhardt Design price lists are, and remain, the property of Bernhardt Design, with the sole right reserved to manufacture and to distribute.

Some of the product designs shown are patented in the United States and will remain the property of Bernhardt Design. Any reproduction of the products constitutes an infringement of patented copyright laws and will be subject to prosecution.

**Environmental**

Some tables and credenzas are LEVEL® for ANSI/BIFMA e3-2019 – Furniture Sustainability Standard and SCS Indoor Advantage™ Gold certified. Visit the product page at [bernhardtdesign.com](http://bernhardtdesign.com) for certifications.



**Preferred Carrier Guaranteed Freight Rates - Canada**

Freight charges will be applied to orders as a separate line item based on the zones listed. Rates are based on zones with a minimum for each zone.

The freight amount is calculated on the total merchandise list COM price. Additional freight fuel surcharges may apply. Rates are based on deliveries made Monday through Friday, 8 am until 5 pm.

All orders are shipped by Bernhardt Design company trucks or preferred carriers specified by Bernhardt Design. If a purchase order does not specify that the product must ship complete, Bernhardt Design reserves the right to select the most effective shipping method necessary, including split shipments. Dealer warehouse information, including phone number and contact name, must be specified on the purchase order.

Direct site deliveries may be requested with an additional freight cost. Requests for direct site deliveries must be made 2 weeks prior to the scheduled ship week and meet the following criteria:

- Minimum of half truckload
- Delivery site accessible by a 53' trailer
- Complete delivery site address with contact name and on-site phone number
- Labor available for unloading

Deliveries that do not meet the criteria must be directed to a receiver warehouse. If a receiver warehouse is not available, the dealer may make arrangements with their own 3rd party carrier. If a 3rd party carrier is elected, a contact name, phone number and e-mail address is required.

Bernhardt Design has a no touch freight policy. Drivers are not allowed to unload freight.

Weekend direct site deliveries will incur a \$500 per trailer weekend delivery fee. Weekend is defined as between 5 pm Friday and 8 am Monday.

Customers who decline GFP should refer to the shipping section of the Terms and Conditions page.

Zone	Minimums	Freight	Avg. Bus. Days
Zone 1	\$200	5%	10-15
Zone 2	\$200	9%	10-15
Zone 3	\$200	8%	10-15
Zone 4	\$200	11%	10-15
Zone 5	Quote	Quote	

The attached rates are strictly freight and do not include brokerage fees.

