

seating
price list

january 2025

seating section index

barstools	6-21	accessories - pillows	546-549	powder coat selections - PLANK	558
ottomans/benches	22-57	accessories - stacking carts	550-552	polyethylene selections - PLANK	558
swivel	58-82	accessories - general	553	polypropylene selections - PLANK	558
guest	83-122	veneer selections	554-555	graded-in textiles	559-565
lounge	123-189	powder coat selections	556	term and conditions	566-569
lounge - modular	190-545	veneer & metal selections - PLANK	557	freight	570-571

seating product alphabetical index

abra	123	chapelle	141-146	glasgow lounge	167-168	neve	108
ace	6	charlotte	88	go®	93	nico	184
alloro	190-217	chiara	147-148	halo	94	orbit®	109
alta	58-65	chloe swivel	68	harmony	311-356	orbit® wood	108-109
anne	83, 123	chloe guest	88-90	harper	169	oslo	184
apel	22-23	cinema lounge	148	helium	95	oslo.02	185
aro	7-8	cinema lounge modular	236-247	ibis	169-170	pasadena	480-540
astra	124	claire	149	item	357-362	pause	56
atlantic	125	claris	90	jackson	170-175	prelude barstools	20-21
aubry	66	code lounge	149-158	kl	13-14	prelude guest	110-111
automatic	125-126	code lounge modular	248-269	kylo	72-73	prelude lounge	185-187
avant	83	colours	270-280	l.a.m.	73-75	prelude swivel	76
balance	24-25	cooper	91	land	176-177	queue	112
bardot	127-128	corvo	91-92	largo	15	ravel	187-188
becca lounge	128-131	cp.1 ottoman/benches	26-27	lava	75	remo	112-118
becca lounge modular	218-226	cp.1 lounge	158-159	lily	177-178	renn	77
belmont	131-132	cp.2 ottoman/benches	28	lilypad	179-180	rice	77-81
blaine	133	cp.2 lounge	159	loft	180	rkc	189
blaine.02	134	cup	160	luca ottoman/benches	44-54	session	118
blitz	84	darby	12	luca lounge modular	363-392	sonar	119-121
blocco	9-11	decorative pillows	554-557	matinee	95-96	stacking carts	560-562
bombom	135	diego	160-161	mellow	181	stay	56
canelle	136-139	duet	68-72	mezzo	16-18	tour	57
cantata	140	elevation	30-27	mirador ottoman/benches	55	valentina	541-545
capri	84	elio	161-162	mirador lounge modular	393-429	valera	81-82
casino	227-235	finale	162-164	mitt	182-183	velit	121-122
catherine	141	friends	281-306	miura	19	vika	189
catia	25	gaia lounge	164-167	monza	96-106		
celon	85	gaia lounge modular	307-310	mulholland	107		
chantal swivel	67	gallery	38-43	myto	107		
chantal guest	86-87	glasgow guest	92-93	neighborhood	430-479		

111 ganging bracket	54, 392	1084, 1084L becca	221	1560U mezzo	16	2405A oslo.02	185
558 rice	77	1085, 1085L becca	129-130	1560W mezzo	16	3302, 3303, 3304 lily	177-178
559, 560 rice	78	1087, 1087L becca	130-131	1561C mezzo	17	3305 rkc	189
561, 562 rice	79	1088, 1088L becca	222	1561U mezzo	17	3306RB, 3307LB lilypad	179-180
563, 564 rice	80	1089, 1089L becca	223	1561W mezzo	18	3401, 3402 belmont	131-132
565 rice	81	1095, 1095K, 1097, 1097K ibis	168-170	1566, 1567 darby	12	3801A - 3804AK elevation	31-33
570, 571, 572 duet	68-69	1100-00 land	176	1570, 1570U cooper	91	3812A - 3814AK elevation	33-34
573, 574, 574K duet	70	1101, 1102 orbit® wood	108-109	1571 mulholland	107	3820A - 3823A elevation	36-37
575, 576, 576K duet	71	1103 orbit®	109	1574 prelude guest	110	4680, 4681 jackson	170-175
577 duet	72	1105 stacking cart	550	1575, 1576 prelude guest	111	4700 vika	189
580, 580F, 580K alta	58	1106, 1108 halo	94	1577 prelude swivel	76	4742, 4745, 4747 bardot	127-128
581, 581F, 581K alta	62	1126, 1126B sonar	119	1578, 1579 prelude barstools	20-21	4750 catherine	141
582, 582F, 582K alta	59-60	1126U, 1126UB sonar	119	1580, 1581 largo	15	4755, 4755W chiara	147-148
583, 583F, 583K alta	63-64	1127, 1127B sonar	120	1585U blitz	84	4756, 4756P canelle	136-137
584, 584F, 584K alta	60-61	1127U, 1127UB sonar	120	1605 claris	90	4757M, 4757PM canelle	138
585, 585F, 585K alta	64-65	1128, 1128B sonar	121	1615 session	118	4757W, 4757PW canella	139
586, 587, 588, 589 l.a.m.	73-75	1150-00 land	176	1700-1770 stacking carts	550-552	4772, 4774 astra	124
594 lava	75	1170, 1171 ace	6	1710, 1711 corvo	91-92	4792 catia	25
600, 600K kylo	72	1200, 1201 matinee	95-96	1712 helium	95	4799 claire	149
602, 602K kylo	73	1202, 1203 cantata	140	1714, 1715 capri	84	4800 cinema	148
605 aubry	66	1207-20 myto	107	1717 charlotte	88	4811-4826 cinema	236-247
608C, 608W valera	81-82	1209-40 monza	96-99	1718C, 1718W neve	108	4831- 4843 colours	270-280
610 renn	77	1209-40-98 monza	100-102	1800-40 velit	121	4862, 4864 elio	161-162
1011, 1011SW go®	93	1209-40-99 monza	103-106	1800-40-99 velit	122	4874-4897 chapelle	141-146
1019M chloe	90	1209-90 monza linking device	553	1800-99 velit	122	4970-4982 casino	227-235
1020 chloe	88	1415-10 remo	112	1889 harper	169	4B11SX-4B37SR alloro	212-217
1021 chloe	89	1415-10-99 remo	113	1890 anne	83, 123	4C15SL-4C27SR alloro	199-203
1022 chloe	68	1415-20 remo	113	1995, 1996 avant	83	4D25SL-4D37SR alloro	204-211
1023 chantal	86	1415-20-99 remo	114	1960-12 cup	160	4F15SL-4F37SX alloro	192-198
1024 chantal	87	1416-20 remo	115	2100-2147C code lounge	149-158	5047, 5048, 5049, 5050 mellow	181
1025 chantal	67	1416-20-99 remo	116	2160-2197 code modular	248-269	5281-5284 gallery	38-40
1026M chantal	87	1417-20 remo	117	2202, 2205, 2207 gaia	164-165	5291, 5291M gallery	41
1037 queue	112	1417-20-99 remo	117	2215, 2225 gaia	308	5295, 5295M gallery	42
1050-00 land	177	1418-20 remo	118	2217, 2227 gaia	309	5297, 5297M gallery	43
1076, 1076K bombom	135	1518, 1519, 1520 aro	7	2250 gaia	310	5604, 5605 prelude	185-186
1079, 1079L becca	224	1521, 1522, 1523 aro	8	2302, 2305, 2307 gaia	166-167	5606-5607 prelude high back	186-187
1080, 1080L becca	225	1525, 1526 celon	85	2315, 2325 gaia	308	5650-5655 valentina	543-545
1081, 1081L becca	226	1558, 1558K kl	13	2317, 2327 gaia	309	5682, 5682C, 5683 diego	160-161
1082, 1082L becca	128-129	1559, 1559K kl	14	2401 loft	180	5720 5720L mitt	182
1083, 1083L becca	220	1560C mezzo	18	2405 oslo	184	5721, 5721L mitt	183

5730, 5730W, 5731 automatic	125-126	6180 abra	123	8042A mirador	55, 429	8D33L, 8D33R luca	390-391
5838 pause	56	6262 atlantic	125	8200-00 miura	19	8D35L, 8D35R luca	369-370
5850, 5851 apel	22-23	6458 blaine	133	8255 nico	184	8D36D, 8D42D luca	47
5860, 5860G stay	56	6459 blaine.02	134	8500-00 blocco	9-10	8D37L, 8D37R luca	373-374
5880 tour	57	6460 blaine.02	134	8500-60 blocco	10-11	8D45L, 8D45R luca	372
5900-5905 item	359-362	6465 blaine	133	8D01N luca	49, 387	8D47L, 8D47R luca	376
5B5XX friends	300	6492 glasgow	92, 167	8D02N luca	50, 388	8D48D, 8D60D luca	48
5B7XX friends	305	6493 glasgow	93, 168	8D05N luca	49, 387	8D55L, 8D55R luca	371
5C5XX friends	306	6494 glasgow	93, 168	8D06N, 8P06N luca	52, 386	8D57L, 8D57R luca	375
5D5LC, 5D5RC friends	297	6501, 6501B, 6501K cp.1	158-159	8D07N luca	50, 388	K1A-K6E harmony	311-356
5D5LU, 5D5RU friends	296	6502, 6502B, 6502K cp.2	159	8D08N, 8P08N luca	53, 385	PA01 decorative pillows	546
5D5LW, 5D5RW friends	298	6503, 6503B, 6503K cp.1	26	8D09N luca	51, 389	PA02 decorative pillows	546
5D5LX, 5D5RX friends	299	6504, 6504b, 6504K cp.2	28	8D15N luca	370	PA03 decorative pillows	546
5D7LC, 5D7RC friends	302	6505, 6505B, 6505K cp.1	27	8D16L, 8P16L luca	381-382	PA04 decorative pillows	547
5D7LU, 5D7RU friends	301	6506, 6506B, 6506K cp.2	28-29	8D16R, 8P16R luca	383-384	PA05 decorative pillows	547
5D7LW, 5D7RW friends	303	6510L, 6510BL, 6510KL finale	162-163	8D17N luca	374	PA06 decorative pillows	547
5D7LX, 5D7RX friends	304	6517L, 6517BL, 6517KL finale	163-164	8D25N luca	368, 369	PA07 decorative pillows	548
5F5XC-5F5XX friends	288-291	6860, 6861, 6865 balance	24	8D26L, 8P26L luca	377-378	PB01 decorative pillows	549
5F7XC-5F7XX friends	292-295	6867 balance	25	8D26R, 8P26R luca	379-380	PB02 decorative pillows	549
6019-6049 neighborhood	446-479	6ALL-6WSX pasadena	486-540	8D27N luca	368, 373	V10, V60 elevation	35
6170A ravel	187	8010-8045 mirador	399-428	8D31N luca	390		
6170W, 6177A, 6177W ravel	188	8040A, 8041A mirador	55, 429	8D32N luca	389		

adore	563	daybreak	559	loop	560	sereno	561
align	559	delight	559	mesh	562	shift	562
allude	561, 565	diffuse	559	midnight	562	sketch	559
aspire	563	elan	565	mirage	563	smooth	560
bangkok	562	element	560	muse	564	snug	563
bella	562	emerge	559, 565	nightfall	562	soft	561
blended	562, 565	essential	565	océane	564	soft spun	560
bomber jacket	559, 565	focus	562	palette	561	solo	559
brisa	561, 565	forte	563	patina	563	still	559
cadence	561	fresca	562	pearl	561	stitch	561
cameo	564	hendese	562	perfect plaid	562	tailored	563
canvas	560, 565	hero	561	pix	560	twilight	563
capture	563	image	561, 565	plush	561	urban	560
cherish	559	imprint	564	pocket square	559	valencia	564
chunky	561	ink	560	posh	564	vella	560
cielo	561	istanbul	562	random	561	venture	563
classic fit	559	kavir	559	rogue	565	vista	560
crafted wool	563	kumasi	563	roma	563	vivid	561
crosshatch	559	london	565	sella	562		

ace 1170

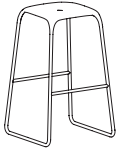

Barstool
 Chrome or powder coat frame
 Polypropylene seat

Seat: 13 $\frac{3}{4}$ " x 13 $\frac{3}{4}$ "

SCS Indoor Advantage™ Gold and LEVEL® 2 Certified. See terms and conditions for additional finish and environmental information.

Seat Height	Arm Height	W	D	H	Fabric	Leather	Weight	Cubes/Qty
29 $\frac{1}{2}$ "	-	18 $\frac{3}{4}$ "	18 $\frac{1}{4}$ "	29 $\frac{1}{2}$ "	-	-	17 lbs	6.48/1
750 mm	-	467 mm	464 mm	750 mm	-	-	7.7 kg	.18 cu

List Price
743

sku

1	1	7	0
---	---	---	---

frame

G	charcoal grey powder coat steel frame with matching seat
W	white steel frame with matching seat
WC	polished chrome frame with white polypropylene seat

ace 1171



Counter height stool
 Chrome or powder coat frame
 Polypropylene seat

Seat: 13 $\frac{3}{4}$ " x 13 $\frac{3}{4}$ "

SCS Indoor Advantage™ Gold and LEVEL® 2 certified. See terms and conditions for additional finish and environmental information.

Seat Height	Arm Height	W	D	H	Fabric	Leather	Weight	Cubes/Qty
25 $\frac{1}{4}$ "	-	17 $\frac{3}{4}$ "	17 $\frac{1}{2}$ "	25 $\frac{1}{4}$ "	-	-	16 lbs	5.64/1
641 mm	-	448 mm	445 mm	641 mm	-	-	7.3 kg	.15 cu

List Price
699

sku

1	1	7	1
---	---	---	---

frame

G	charcoal powder coat frame with matching seat
W	white steel frame with matching seat
WC	polished chrome frame with white polypropylene seat

aro 1518

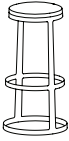

Swivel barstool
Polished stainless steel frame
Solid maple seat

Seat available in all maple finishes. When specifying light finishes the natural characteristics of the wood will be visible and color will vary.

SCS Indoor Advantage™ Gold and LEVEL® 2 certified. See terms and conditions for additional finish and environmental information.

Seat Height	Arm Height	W	D	H	Fabric	Leather	Weight	Cubes/Qty
31¼"	-	16¾"	16¾"	31¼"	-	-	28 lbs	10.36'/1
806 mm	-	416 mm	416 mm	806 mm	-	-	12.7 kg	.29 cu

List Price
2109

aro 1519



Swivel counter height stool
Polished stainless steel frame
Solid maple seat

Seat available in all maple finishes. When specifying light finishes the natural characteristics of the wood will be visible and color will vary.

SCS Indoor Advantage™ Gold and LEVEL® 2 certified. See terms and conditions for additional finish and environmental information.

Seat Height	Arm Height	W	D	H	Fabric	Leather	Weight	Cubes/Qty
24½"	-	15½"	15½"	24½"	-	-	25 lbs	7.56'/1
613 mm	-	403 mm	403 mm	613 mm	-	-	11.3 kg	.21 cu

List Price
1892

aro 1520

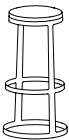

Swivel barstool
Polished stainless steel frame
Solid walnut seat

Seat available in all walnut finishes. When specifying light finishes the natural characteristics of the wood will be visible and color will vary.

SCS Indoor Advantage™ Gold and LEVEL® 2 certified. See terms and conditions for additional finish and environmental information.

Seat Height	Arm Height	W	D	H	Fabric	Leather	Weight	Cubes/Qty
31¼"	-	16¾"	16¾"	31¼"	-	-	28 lbs	7.56'/1
806 mm	-	416 mm	416 mm	806 mm	-	-	12.7 kg	.21 cu

List Price
2163

aro 1521



Swivel counter height stool
Polished stainless steel frame
Solid walnut seat

Seat available in all walnut finishes. When specifying light finishes the natural characteristics of the wood will be visible and color will vary.

SCS Indoor Advantage™ Gold and LEVEL® 2 certified. See terms and conditions for additional finish and environmental information.

Seat Height	Arm Height	W	D	H	Fabric	Leather	Weight	Cubes/Qty
24½"	-	15⅞"	15⅞"	24½"	-	-	25 lbs	7.56'/1
613 mm	-	403 mm	403 mm	613 mm	-	-	11.3 kg	.21 cu

List Price
1945

aro 1522

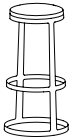

Swivel barstool
Polished stainless steel frame
Upholstered seat

Certain thick or heavy pile fabrics or fabrics with very little stretch are not suitable for application on this product.

SCS Indoor Advantage™ Gold and LEVEL® 2 certified. See terms and conditions for additional finish and environmental information.

Seat Height	Arm Height	W	D	H	Fabric	Leather	Weight	Cubes/Qty
31¼"	-	16⅝"	16⅝"	31¼"	.75 yd.	10.0'	28 lbs	10.36'/1
806 mm	-	416 mm	416 mm	806 mm	.7 m	.93 sqm	12.7 kg	.29 cu

COM	COL	1	2	3	4	5	6	7	8	9	10	11
1945	1960	2015	2027	2034	2047	2059	2064	2072	2084	2094	2105	2172

aro 1523



Swivel counter height stool
Polished stainless steel frame
Upholstered seat

Certain thick or heavy pile fabrics or fabrics with very little stretch are not suitable for application on this product.

SCS Indoor Advantage™ Gold and LEVEL® 2 certified. See terms and conditions for additional finish and environmental information.

Seat Height	Arm Height	W	D	H	Fabric	Leather	Weight	Cubes/Qty
24½"	-	15⅞"	15⅞"	24½"	.75 yd.	10.0'	25 lbs	7.56'/1
613 mm	-	403 mm	403 mm	613 mm	.7 m	.93 sqm	11.3 kg	.21 cu

COM	COL	1	2	3	4	5	6	7	8	9	10	11
1734	1749	1804	1816	1823	1836	1848	1853	1861	1873	1883	1894	1961

blocco 8500-00 ash

PLANK

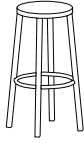

Barstool
Solid ash frame
Satin or polished aluminum footrest

Available in Plank ash finishes. When specifying light finishes the natural characteristics of the wood will be visible and color will vary.

ANSI/BIFMA certified.

Seat Height	Arm Height	W	D	H	Fabric	Leather	Weight	Cubes/Qty
29 7/8"	-	18 7/8"	13 3/8"	29 7/8"	-	-	15 lbs.	7.75'/1
759 mm	-	480 mm	340 mm	759 mm	-	-	6.9 kg	.22 cu.

Aluminum Satin	Aluminum Polished
1050	1210

sku	frame finish	footrest finish	glides
8 5 0 0 - 0 0	AN ash natural AWH ash white AG ash grey ABL ash blue AB ash black	ALS aluminum satin ALP aluminum polished	ST standard FT felt

blocco 8500-00 walnut

PLANK

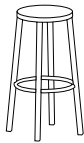

Barstool
Solid walnut frame
Satin or polished aluminum footrest

Available in Plank canaletto walnut natural finish.

ANSI/BIFMA certified.

Seat Height	Arm Height	W	D	H	Fabric	Leather	Weight	Cubes/Qty
29 7/8"	-	18 7/8"	13 3/8"	29 7/8"	-	-	15 lbs.	7.75'/1
759 mm	-	480 mm	340 mm	759 mm	-	-	6.9 kg	.22 cu.

Aluminum Satin	Aluminum Polished
1471	1631

sku	frame finish	footrest finish	glides
8 5 0 0 - 0 0	WLT canaletto walnut natural	ALS aluminum satin ALP aluminum polished	ST standard FT felt

blocco 8500-00 oak

PLANK

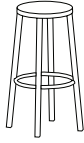

Barstool
Solid oak frame
Satin or polished aluminum footrest

Available in Plank oak natural finish. When specifying light finishes the natural characteristics of the wood will be visible and color will vary.

ANSI/BIFMA certified.

Seat Height	Arm Height	W	D	H	Fabric	Leather	Weight	Cubes/Qty
29 7/8"	-	18 7/8"	13 3/8"	29 7/8"	-	-	15 lbs.	7.75/1
759 mm	-	480 mm	340 mm	759 mm	-	-	6.9 kg	.22 cu.

Aluminum Satin	Aluminum Polished
1084	1243

sku	frame finish	footrest finish	glides
8 5 0 0 - 0 0	OAK oak natural O A K	ALS aluminum satin ALP aluminum polished 	ST standard FT felt

blocco 8500-60 ash

PLANK

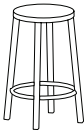

Counter stool
Solid ash frame
Satin or polished aluminum footrest

Available in Plank ash finishes. When specifying light finishes the natural characteristics of the wood will be visible and color will vary.

ANSI/BIFMA certified.

Seat Height	Arm Height	W	D	H	Fabric	Leather	Weight	Cubes/Qty
24 3/4"	-	17 3/4"	13 3/8"	24 3/4"	-	-	15 lbs.	7.75/1
629 mm	-	451 mm	340 mm	629 mm	-	-	6.9 kg	.22 cu.

Aluminum Satin	Aluminum Polished
1038	1199

sku	frame finish	footrest finish	glides
8 5 0 0 - 6 0	AN ash natural AWH ash white AG ash grey ABL ash blue AB ash black 	ALS aluminum satin ALP aluminum polished 	ST standard FT felt

blocco 8500-60 walnut

PLANK

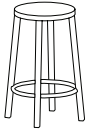

Counter stool
Solid walnut frame
Satin or polished aluminum footrest

Available in Plank canaletto walnut natural finish.

ANSI/BIFMA certified.

Seat Height	Arm Height	W	D	H	Fabric	Leather	Weight	Cubes/Qty
24 3/4"	-	17 3/4"	13 3/8"	24 3/4"	-	-	15 lbs.	7.75'/1
629 mm	-	451 mm	340 mm	629 mm	-	-	6.9 kg	.22 cu.

Aluminum Satin	Aluminum Polished
1461	1620

sku	frame finish	footrest finish	glides
8 5 0 0 - 6 0	WLT canaletto walnut natural W L T	ALS aluminum satin ALP aluminum polished 	ST standard FT felt

blocco 8500-60 oak

PLANK



Counter stool
Solid oak frame
Satin or polished aluminum footrest

Available in Plank oak natural finish. When specifying light finishes the natural characteristics of the wood will be visible and color may vary.

ANSI/BIFMA certified.

Seat Height	Arm Height	W	D	H	Fabric	Leather	Weight	Cubes/Qty
24 3/4"	-	17 3/4"	13 3/8"	24 3/4"	-	-	15 lbs.	7.75'/1
629 mm	-	451 mm	340 mm	629 mm	-	-	6.9 kg	.22 cu.

Aluminum Satin	Aluminum Polished
1073	1233

sku	frame finish	footrest finish	glides
8 5 0 0 - 6 0	OAK oak natural O A K	ALS aluminum satin ALP aluminum polished 	ST standard FT felt

darby 1566



Barstool
Solid ash frame
Upholstered seat cushion

Frame available in all ash finishes. When specifying light finishes the natural characteristics of the wood will be visible and color will vary.

Inside Seat Width: 17½" Inside Seat Depth: 16½" Inside Back Height: 5"

SCS Indoor Advantage™ Gold and LEVEL® 2 certified. See terms and conditions for additional environmental information.

Seat Height	Arm Height	W	D	H	Fabric	Leather	Weight	Cubes/Qty
30 1/4"	3"	23 1/2"	18 5/8"	34 3/4"	.75 yds	10'	31 lbs	21.35'/1
768 mm	76 mm	597 mm	473 mm	883 mm	.69 m	.93 sqm	14.1 kg	.6 cu

COM	COL	1	2	3	4	5	6	7	8	9	10	11
988	1003	1058	1070	1077	1090	1102	1107	1115	1127	1137	1148	1215

darby 1567



Counter height stool
Solid ash frame
Upholstered seat cushion

Frame available in all ash finishes. When specifying light finishes the natural characteristics of the wood will be visible and color will vary.

Inside Seat Width: 17½" Inside Seat Depth: 16½" Inside Back Height: 5"

SCS Indoor Advantage™ Gold and LEVEL® 2 certified. See terms and conditions for additional environmental information.

Seat Height	Arm Height	W	D	H	Fabric	Leather	Weight	Cubes/Qty
25 1/2"	3"	23 1/8"	17 5/8"	30 1/2"	.75 yds	10'	30 lbs	21.35'/1
648 mm	76 mm	587 mm	448 mm	775 mm	.69 m	.93 sqm	13.6 kg	.6 cu

COM	COL	1	2	3	4	5	6	7	8	9	10	11
962	977	1032	1044	1051	1064	1076	1081	1089	1101	1111	1122	1189

kl 1558



Barstool
Solid maple frame
Polished stainless steel footrest
Upholstered

Frame available in all maple finishes. When specifying light finishes the natural characteristics of the wood will be visible and color will vary.

Certain thick or heavy pile fabrics or fabrics with very little stretch are not suitable for application on this product.

When using a combination of fabrics or leather, specify the application by designating the appropriate letter, shown below, on the purchase order. Yardage shown must be used.

See terms and conditions for contrasting fabric upcharges.

- A) One fabric or leather for seat
yardage: 1.0 yds. leather: 17.0 sq. ft.
- B) One fabric or leather for seat back
yardage: 1.0 yds. leather: 17.0 sq. ft.

SCS Indoor Advantage™ Gold and LEVEL® 2 certified. See terms and conditions for additional finish and environmental information.

Seat Height	Arm Height	W	D	H	Fabric	Leather	Weight	Cubes/Qty
30"	-	17 3/4"	20 1/4"	39 1/4"	2.0 yds	33.0'	25 lbs	21.82/1
762 mm	-	451 mm	514 mm	997 mm	1.8 m	3.1 sqm	11.4 kg	.62 cu

COM	COL	1	2	3	4	5	6	7	8	9	10	11
1776	1816	1963	1994	2012	2048	2079	2092	2114	2145	2172	2203	2381

kl 1558K



Barstool
Solid maple frame
Matte black powder coat footrest
Upholstered

Frame available in all maple finishes. When specifying light finishes the natural characteristics of the wood will be visible and color will vary.

Certain thick or heavy pile fabrics or fabrics with very little stretch are not suitable for application on this product.

When using a combination of fabrics or leathers, specify the application by designating the appropriate letter, shown below, on the purchase order. Yardage shown must be used.

See terms and conditions for contrasting fabric upcharges.

- A) One fabric or leather for seat
yardage: 1.0 yds. leather: 17.0 sq. ft
- B) One fabric or leather for seat back
yardage: 1.0 yds. leather: 17.0 sq. ft.

SCS Indoor Advantage™ Gold and LEVEL® 2 certified. See terms and conditions for additional finish and environmental information.

Seat Height	Arm Height	W	D	H	Fabric	Leather	Weight	Cubes/Qty
30"	-	17 3/4"	20 1/4"	39 1/4"	2.0 yds	33.0'	25 lbs	21.82/1
762 mm	-	451 mm	514 mm	997 mm	1.8 m	3.1 sqm	11.4 kg	.62 cu

COM	COL	1	2	3	4	5	6	7	8	9	10	11
1880	1920	2067	2098	2116	2152	2183	2196	2218	2249	2276	2307	2485

kl 1559



Counter height stool
 Solid maple frame
 Polished stainless steel footrest
 Upholstered

Frame available in all maple finishes. When specifying light finishes the natural characteristics of the wood will be visible and color will vary.

Certain thick or heavy pile fabrics or fabrics with very little stretch are not suitable for application on this product.

When using a combination of fabrics or leathers, specify the application by designating the appropriate letter, shown below, on the purchase order. Yardage shown must be used.

See terms and conditions for contrasting fabric upcharges.

- A) One fabric or leather for seat
 yardage: 1.0 yds. leather: 17.0 sq. ft.
- B) One fabric or leather for seat back
 yardage: 1.0 yds. leather: 17.0 sq. ft.

SCS Indoor Advantage™ Gold and LEVEL® 2 certified. See terms and conditions for additional finish and environmental information.

Seat Height	Arm Height	W	D	H	Fabric	Leather	Weight	Cubes/Qty
25½"	-	17¾"	20¼"	34¾"	2.0 yds	33.0'	25 lbs	21.82/1
648 mm	-	451 mm	514 mm	883 mm	1.8 m	3.1 sqm	11.4 kg	.62 cu

COM	COL	1	2	3	4	5	6	7	8	9	10	11
1741	1781	1928	1959	1977	2013	2044	2057	2079	2110	2137	2168	2346

kl 1559K



Counter height stool
 Solid maple frame
 Matte black powder coat footrest
 Upholstered

Frame available in all maple finishes. When specifying light finishes the natural characteristics of the wood will be visible and color will vary.

Certain thick or heavy pile fabrics or fabrics with very little stretch are not suitable for application on this product.

When using a combination of fabrics or leathers, specify the application by designating the appropriate letter, shown below, on the purchase order. Yardage shown must be used.

See terms and conditions for contrasting fabric upcharges.

- A) One fabric or leather for seat
 yardage: 1.0 yds. leather: 17.0 sq. ft.
- B) One fabric or leather for seat back
 yardage: 1.0 yds. leather: 17.0 sq. ft.

SCS Indoor Advantage™ Gold and LEVEL® 2 certified. See terms and conditions for additional finish and environmental information.

Seat Height	Arm Height	D	W	H	Fabric	Leather	Weight	Cubes/Qty
25 1/2"	-	20 1/4"	17 3/4"	34 3/4"	2.0 yds	33.0'	25 lbs	21.82/1
648 mm	-	451 mm	514 mm	883 mm	1.8 m	3.1 sqm	11.4 kg	.62 cu

COM	COL	1	2	3	4	5	6	7	8	9	10	11
1844	1884	2031	2062	2080	2116	2147	2160	2182	2213	2240	2271	2449

largo 1580



Barstool
Solid walnut frame
Upholstered seat pad

Brushed graphite stainless steel stretcher

Only available in walnut LV8 finish.

Inside Seat Depth: 14¼"

SCS Indoor Advantage™ Gold and LEVEL® 2 certified. See terms and conditions for additional environmental information.

Seat Height	Arm Height	W	D	H	Fabric	Leather	Weight	Cubes/Qty
30"	-	16 1/2"	16 1/2"	30 3/4"	1.0 yds	18.0'	23 lbs	7.03/1
762 mm	-	419 mm	419 mm	781 mm	.91 m	1.7 sqm	10.4 kg	.19 cu

COM	COL	1	2	3	4	5	6	7	8	9	10	11
1456	1476	1550	1565	1574	1592	1608	1614	1625	1641	1654	1670	1759

largo 1581



Counter height stool
Solid walnut frame
Upholstered seat pad

Brushed graphite stainless steel stretcher

Only available in walnut LV8 finish.

Inside Seat Depth: 14¼"

SCS Indoor Advantage™ Gold and LEVEL® 2 certified. See terms and conditions for additional environmental information.

Seat Height	Arm Height	W	D	H	Fabric	Leather	Weight	Cubes/Qty
26 1/8"	-	16 1/2"	16 1/2"	26 5/8"	1.0 yds	18.0'	24 lbs	7.03/1
664 mm	-	419 mm	419 mm	676 mm	.91 m	1.7 sqm	10.9 kg	.19 cu

COM	COL	1	2	3	4	5	6	7	8	9	10	11
1352	1372	1446	1461	1470	1488	1504	1510	1521	1537	1550	1566	1655

mezzo 1560U



Barstool
 Polished chrome or powder coat frame
 Upholstered
 Non-marring glides

Certain thick or heavy pile fabrics or fabrics with very little stretch are not suitable for application on this product.

SCS Indoor Advantage™ Gold and LEVEL® 2 certified. See terms and conditions for additional finish and environmental information.

Seat Height	Arm Height	W	D	H	Fabric	Leather	Weight	Cubes/Qty
30 1/8"	-	18 3/4"	18 3/4"	38 1/4"	1.0 yds	20.0'	34 lbs	21.5'/1
765 mm	-	476 mm	476 mm	972 mm	.92 m	1.86 sqm	15.4 kg	.61 cu

COM	COL	1	2	3	4	5	6	7	8	9	10	11
1316	1336	1410	1425	1434	1452	1468	1474	1485	1501	1514	1530	1619

sku

1 | 5 | 6 | 0 | U

frame finish

polished chrome standard, OR
 specify powder coat, upcharge \$75
K matte black powder coat
W satin white powder coat

mezzo 1560W



Barstool
 Polished chrome or powder coat frame
 Walnut veneer seat

Non-marring glides

Seat available in all walnut finishes except LV8. When specifying light finishes the natural characteristics of the wood will be visible and color will vary.

SCS Indoor Advantage™ Gold and LEVEL® 2 certified. See terms and conditions for additional finish and environmental information.

Seat Height	Arm Height	W	D	H	Fabric	Leather	Weight	Cubes/Qty
30 1/8"	-	18 3/4"	18 3/4"	38 1/4"	-	-	31 lbs	21.5'/1
765 mm	-	476 mm	476 mm	972 mm	-	-	14.1 kg	.61 cu

List Price

1172

sku

1 | 5 | 6 | 0 | W

frame finish

polished chrome standard, OR
 specify powder coat, upcharge \$75
K matte black powder coat
W satin white powder coat

mezzo 1561C



Counter height stool
 Polished chrome or powder coat frame
 Oak veneer seat

Non-marring glides

Seat available in all oak finishes. When specifying light finishes the natural characteristics of the wood will be visible and color will vary.

SCS Indoor Advantage™ Gold and LEVEL® 2 certified. See terms and conditions for additional finish and environmental information.

Seat Height	Arm Height	W	D	H	Fabric	Leather	Weight	Cubes/Qty
26"	-	18"	18¾"	34½"	-	-	30 lbs	21.5/1
660 mm	-	457 mm	476 mm	867 mm	-	-	14.0 kg	.61 cu

List Price
1088

sku

frame finish

1 | 5 | 6 | 1 | C |

polished chrome standard, OR

specify powder coat, upcharge \$75

K matte black powder coat

W satin white powder coat

mezzo 1561U



Counter height stool
 Polished chrome or powder coat frame
 Upholstered

Non-marring glides

Certain thick or heavy pile fabrics or fabrics with very little stretch are not suitable for application on this product.

SCS Indoor Advantage™ Gold and LEVEL® 2 certified. See terms and conditions for additional finish and environmental information.

Seat Height	Arm Height	W	D	H	Fabric	Leather	Weight	Cubes/Qty
26"	-	18"	18¾"	34½"	1.0 yds	20.0'	33 lbs	21.5/1
660 mm	-	457 mm	476 mm	867 mm	.92 m	1.86 sqm	15.1 kg	.61 cu

COM	COL	1	2	3	4	5	6	7	8	9	10	11
1289	1309	1383	1398	1407	1425	1441	1447	1458	1474	1487	1503	1592

sku

frame finish

1 | 5 | 6 | 1 | U |

polished chrome, OR

specify powder coat, upcharge \$75

K matte black

W satin white

mezzo 1561W



Counter height stool
Polished chrome or powder coat frame
Walnut veneer seat

Non-marring glides

Seat available in all walnut finishes except LV8. When specifying light finishes the natural characteristics of the wood will be visible and color will vary.

SCS Indoor Advantage™ Gold and LEVEL® 2 certified. See terms and conditions for additional finish and environmental information.

Seat Height	Arm Height	W	D	H	Fabric	Leather	Weight	Cubes/Qty
26"	-	18"	18¾"	34½"	-	-	30 lbs	21.5'/1
660 mm	-	457 mm	476 mm	867 mm	-	-	14.0 kg	.61 cu

List Price
1142

sku

frame finish

1 | 5 | 6 | 1 | W |

polished chrome standard, OR
specify powder coat, upcharge \$75
K matte black powder coat
W satin white powder coat

mezzo 1560C



Barstool
Polished chrome or powder coat frame
Oak veneer seat

Non-marring glides

Seat available in all oak finishes. When specifying light finishes the natural characteristics of the wood will be visible and color will vary.

SCS Indoor Advantage™ Gold and LEVEL® 2 certified. See terms and conditions for additional finish and environmental information.

Seat Height	Arm Height	W	D	H	Fabric	Leather	Weight	Cubes/Qty
30½"	-	18¾"	18¾"	38¼"	-	-	31 lbs	21.5'/1
765 mm	-	476 mm	476 mm	972 mm	-	-	14.1 kg	.61 cu

List Price
1114

sku

frame finish

1 | 5 | 6 | 0 | C |

polished chrome standard, OR
specify powder coat, upcharge \$75
K matte black powder coat
W satin white powder coat

miura 8200-00

PLANK



Stacking barstool
Polypropylene frame

Stacks four high
When using stacking cart 1720-00, stacks 4 high

Indoor and outdoor use

Seat Height	Arm Height	W	D	H	Fabric	Leather	Weight	Cubes/Qty
30 3/4"	-	18 1/2"	15 3/4"	31 7/8"	-	-	16 lbs.	7.75'/1
782 mm	-	470 mm	401 mm	810 mm	-	-	7.3 kg	.22 cu.

List Price
546

sku

frame finish

glides

8	2	0	0	-	0	0
---	---	---	---	---	---	---

01	black	06	yellow green
02	white	08	light blue
03	traffic red	13	wine red
04	pure orange		

ST	standard
TL	teflon
FT	felt

prelude 1578



Barstool
Polished stainless steel or powder coat frame and stretcher
Upholstered

Non-marring glides

Inside seat depth: 17"

When using a combination of fabrics or leathers, specify the application by designating the appropriate letter, shown below, on the purchase order. Yardage shown must be used.

See terms and conditions for contrasting upholstery upcharges.

- A) One fabric or leather for seat
yardage: 1.75 yds. leather: 29.0 sq. ft
- B) One fabric or leather for inside and outside back
yardage: 1.75 yds. leather: 29.0 sq. ft.

SCS Indoor Advantage™ Gold and LEVEL® 2 certified. See terms and conditions for additional finish and environmental information.

Seat Height	Arm Height	W	D	H	Fabric	Leather	Weight	Cubes/Qty
30 1/8"	-	17 1/2"	20"	39"	2 yds	33 .0'	31 lbs.	22.69/1
765 mm	-	445 mm	492 mm	991 mm	1.9 m	3.1 sqm	14.1 kg.	.64 cu.

COM	COL	1	2	3	4	5	6	7	8	9	10	11
1300	1340	1487	1518	1536	1572	1603	1616	1638	1669	1696	1727	1905

sku

1	5	7	8										

powder coat finish

PA polished stainless steel standard, OR

specify powder coat, upcharge \$125

- | | | |
|-----------------------|---------------------|-----------------------|
| WH satin white | GR graphite | SG sage green |
| EC ecru | BZ bronze | RD black red |
| LA latte | IG iron grey | BK matte black |

prelude 1579



Counter height stool
 Polished stainless steel or powder coat frame and stretcher
 Upholstered

Non-marring glides

Inside seat depth: 17"

When using a combination of fabrics or leathers, specify the application by designating the appropriate letter, shown below, on the purchase order. Yardage shown must be used.

See terms and conditions for contrasting upholstery upcharges.

- A) One fabric or leather for seat
 yardage: 1.75 yds. leather: 29.0 sq. ft
- B) One fabric or leather for inside and outside back
 yardage: 1.75 yds. leather: 29.0 sq. ft.

SCS Indoor Advantage™ Gold and LEVEL® 2 certified. See terms and conditions for additional finish and environmental information.

Seat Height	Arm Height	W	D	H	Fabric	Leather	Weight	Cubes/Qty
27 1/4"	-	17 1/2"	20"	36 1/4"	2 yds	33.0'	29 lbs.	22.69/1
692 mm	-	445 mm	508 mm	921 mm	1.9 m	3.1 sqm	13.2 kg.	.64 cu.

COM	COL	1	2	3	4	5	6	7	8	9	10	11
1250	1290	1437	1468	1486	1522	1553	1566	1588	1619	1646	1677	1855

sku

1	5	7	9	

powder coat finish

- PA** polished stainless steel standard, OR
- specify powder coat, upcharge \$125
- WH** satin white **GR** graphite **SG** sage green
- EC** ecru **BZ** bronze **RD** black red
- LA** latte **IG** iron grey **BK** matte black

apel 5850



Ottoman
Fully upholstered
Saddle stitched

SCS Indoor Advantage™ Gold and LEVEL® 2 certified. See terms and conditions for additional environmental information.

Seat Height	Arm Height	W	D	H	Fabric	Leather	Weight	Cubes/Qty
17¼"	-	22¼"	22¼"	17½"	1.6 yds	30.0'	20.0 lbs	7.0/1
438 mm	-	565 mm	565 mm	445 mm	1.5 m	2.8 sqm	9.07 kg	.19 cu

COM	COL	1	2	3	4	5	6	7	8	9	10	11
950	982	1100	1125	1139	1167	1192	1203	1221	1246	1267	1292	1434

apel 5850L



Ottoman
Fully upholstered
Loop master stitched

Thread color must be specified. Reference Apel/Stitching on bernhardtdesign.com for color options.

SCS Indoor Advantage™ Gold and LEVEL® 2 certified. See terms and conditions for additional environmental information.

Seat Height	Arm Height	W	D	H	Fabric	Leather	Weight	Cubes/Qty
17¼"	-	22¼"	22¼"	17½"	1.6 yds	30.0'	20.0 lbs	7.0/1
438 mm	-	565 mm	565 mm	445 mm	1.5 m	2.8 sqm	9.07 kg	.19 cu

COM	COL	1	2	3	4	5	6	7	8	9	10	11
1235	1267	1385	1410	1424	1452	1477	1488	1506	1531	1552	1577	1719

apel 5850M



Mobile ottoman
Fully upholstered
Saddle stitched

Eight small concealed casters

SCS Indoor Advantage™ Gold and LEVEL® 2 certified. See terms and conditions for additional environmental information.

Seat Height	Arm Height	W	D	H	Fabric	Leather	Weight	Cubes/Qty
17½"	-	22¼"	22¼"	17½"	1.6 yds	30.0'	20.0 lbs	7.0/1
445 mm	-	565 mm	565 mm	445 mm	1.5 m	2.8 sqm	9.07 kg	.19 cu

COM	COL	1	2	3	4	5	6	7	8	9	10	11
1140	1172	1290	1315	1329	1357	1382	1393	1411	1436	1457	1482	1624

apel 5850ML



Mobile ottoman
Fully upholstered
Loop master stitched

Eight small concealed casters

Thread color must be specified. Reference Apel/Stitching on bernhardtdesign.com for color options.

SCS Indoor Advantage™ Gold and LEVEL® 2 certified. See terms and conditions for additional environmental information.

Seat Height	Arm Height	W	D	H	Fabric	Leather	Weight	Cubes/Qty
17½"	-	22¼"	22¼"	17½"	1.6 yds	30.0'	20.0 lbs	7.0'/1
445 mm	-	565 mm	565 mm	445 mm	1.5 m	2.8 sqm	9.07 kg	.19 cu

COM	COL	1	2	3	4	5	6	7	8	9	10	11
1421	1453	1571	1596	1610	1638	1663	1674	1692	1717	1738	1763	1905

apel 5851



Ottoman
Fully upholstered
Saddle stitched

SCS Indoor Advantage™ Gold and LEVEL® 2 certified. See terms and conditions for additional environmental information.

Seat Height	Arm Height	W	D	H	Fabric	Leather	Weight	Cubes/Qty
16½"	-	41¼"	41¼"	16½"	3.3 yds	65.0'	66 lbs	32.1'/1
419 mm	-	1048 mm	1048 mm	419 mm	3.0 m	6.0 sqm	29.9 kg	.91 cu

COM	COL	1	2	3	4	5	6	7	8	9	10	11
1938	2004	2246	2298	2327	2386	2437	2459	2496	2547	2591	2642	2936

apel 5851L



Ottoman
Fully upholstered
Loop master stitched

Thread color must be specified. Reference Apel/Stitching on bernhardtdesign.com for color options.

SCS Indoor Advantage™ Gold and LEVEL® 2 certified. See terms and conditions for additional environmental information.

Seat Height	Arm Height	W	D	H	Fabric	Leather	Weight	Cubes/Qty
16½"	-	41¼"	41¼"	16½"	3.3 yds	65.0'	66 lbs	32.1'/1
419 mm	-	1048 mm	1048 mm	419 mm	3.0 m	6.0 sqm	29.9 kg	.91 cu

COM	COL	1	2	3	4	5	6	7	8	9	10	11
2222	2288	2530	2582	2611	2670	2721	2743	2780	2831	2875	2926	3220

balance 6860



**Mobile stool
Fully upholstered**

Six casters

Specify the fabric or leather application by designating the appropriate letter on the purchase order. When using a combination of fabrics or leathers, the following yardage must be used.

See terms and conditions for contrasting upholstery charges.

- A) One fabric or leather for top seat panel
yardage: 0.8 yds. leather: 6.8 sq. ft.
- B) One fabric or leather for body
yardage: 2.0 yds. leather: 21.0 sq. ft.

SCS Indoor Advantage™ Gold and LEVEL® 2 certified. See terms and conditions for additional environmental information.

Seat Height	Arm Height	W	D	H	Fabric	Leather	Weight	Cubes/Qty
18½"	-	19"	19"	18½"	2.8 yds	27.8'	20 lbs	7.0'/1
470 mm	-	483 mm	483 mm	470 mm	2.6 m	2.6 sqm	9 kg	.19 cu

COM	COL	1	2	3	4	5	6	7	8	9	10	11
739	795	1001	1044	1069	1119	1163	1181	1212	1256	1293	1337	1586

balance 6861

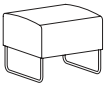

**Ottoman
Polished chrome frame
Upholstered**

SCS Indoor Advantage™ Gold and LEVEL® 2 certified. See terms and conditions for additional environmental information.

Seat Height	Arm Height	W	D	H	Fabric	Leather	Weight	Cubes/Qty
18"	-	20½"	20"	18"	2.3 yds	20.0'	35 lbs	7.0'/1
457 mm	-	521 mm	508 mm	457 mm	2.1 m	1.9 sqm	15.9 kg	.19 cu

COM	COL	1	2	3	4	5	6	7	8	9	10	11
1348	1394	1563	1599	1619	1660	1696	1711	1737	1773	1803	1839	2044

balance 6865

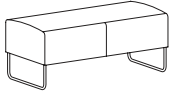

**Two-seat bench
Polished chrome frame
Upholstered**

SCS Indoor Advantage™ Gold and LEVEL® 2 certified. See terms and conditions for additional environmental information.

Seat Height	Arm Height	W	D	H	Fabric	Leather	Weight	Cubes/Qty
18"	-	41½"	20"	18"	2.8 yds	37.7'	55 lbs	29.75'/1
457 mm	-	1054 mm	508 mm	457 mm	2.6 m	3.5 sqm	24.9 kg	.84 cu

COM	COL	1	2	3	4	5	6	7	8	9	10	11
1709	1765	1971	2014	2039	2089	2133	2151	2182	2226	2263	2307	2556

balance 6867

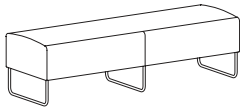

**Three-seat bench
Polished chrome frame
Fully upholstered**

SCS Indoor Advantage™ Gold and LEVEL® 2 certified. See terms and conditions for additional environmental information.

Seat Height	Arm Height	W	D	H	Fabric	Leather	Weight	Cubes/Qty
18"	-	63"	20"	18"	3.6 yds	54.4'	85 lbs	29.75'/1
457 mm	-	1600 mm	508 mm	457 mm	3.3 m	5.1 sqm	38.6 kg	.84 cu

COM	COL	1	2	3	4	5	6	7	8	9	10	11
2375	2447	2711	2767	2799	2863	2919	2943	2983	3039	3087	3143	3463

catia 4792

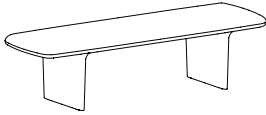

**Two-seat bench
Solid walnut frame
Upholstered**

Available in all walnut finishes. When specifying light finishes the natural characteristics of the wood will be visible and color will vary.

Standard with center seam and welt around seat. For seamless seats specify railroaded. If railroaded add 1.0 yard to fabric or leather alternative requirement. Leather will have center seam.

SCS Indoor Advantage™ Gold and LEVEL® 1 certified. See terms and conditions for additional finish and environmental information.

Seat Height	Arm Height	W	D	H	Fabric	Leather	Weight	Cubes/Qty
17½"	-	67"	21¼"	17½"	2.5 yds	41.0'	106 lbs	37.62'/1
448 mm	-	1702 mm	540 mm	448 mm	1.4 m	3.1 sqm	48.1 kg	1.07 cu

COM	COL	1	2	3	4	5	6	7	8	9	10	11
4377	4427	4611	4650	4672	4716	4755	4772	4800	4839	4872	4911	5133

colours

4831 - 4843 Colours Modular Lounge

Colours: a modular seating product comprised of 12 unique modules which may be used interchangeably to create an unlimited number of configurations.

For complete information, reference Colours in the lounge / modular section of the price list.

cp.1 6503/6503B



**Ottoman
Loop stitch cording
Quilted seat**

6503 Polished stainless steel base
6503B Brushed stainless steel base

Base dimensions: 23¾"w x 18¼"d x 13½"h

A loop stitch cording traces the perimeter of the ottoman. Contrasting thread options are available. For thread color options reference CP.1/Stitching on BernhardtDesign.com.

Available in leather, coated fabrics, suede or felt only. Firm, non-flexible leathers not recommended.

SCS Indoor Advantage™ Gold and LEVEL® 2 Certified. See terms and conditions for additional environmental information.

Seat Height	Arm Height	W	D	H	Fabric	Leather	Weight	Cubes/Qty
15½"	-	26¾"	22"	15½"	2.2 yds.	27.0'	31 lbs.	11.46'/1
391 mm	-	680 mm	559 mm	403 mm	2.0 m	2.5 sqm	14.1 kg	.32 cu.

COM	COL	1	2	4	6	7
2005	2049	2211	2245	2304	2353	2377

cp.1 6503K



Ottoman
Matte black powder coat base
Loop stitch cording
Quilted seat

Base dimensions: 23³/₈"w x 18³/₄"d x 13¹/₂"h

A loop stitch cording traces the perimeter of the ottoman. Contrasting thread options are available. For thread color options reference CP.1/Stitching on bernhardtdesign.com.

Available in leather, leather alternatives, suede or felt only. Firm, non-flexible leathers not recommended.

SCS Indoor Advantage™ Gold and LEVEL® 2 Certified. See terms and conditions for additional environmental information.

Seat Height	Arm Height	W	D	H	Fabric	Leather	Weight	Cubes/Qty
15 ⁷ / ₈ "	-	26 ³ / ₄ "	22"	15 ⁷ / ₈ "	2.2 yds.	27.0'	31 lbs.	11.46/1
391 mm	-	680 mm	559 mm	403 mm	2.0 m	2.5 sqm	15.2 kg	.32 cu.

COM	COL	1	2	4	6	7
2163	2207	2369	2403	2462	2511	2535

cp.1 6505/6505B

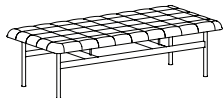

Two-seat bench
Loop stitch cording
Quilted seat
6505 Polished stainless steel base
6505B Brushed stainless steel base

Base dimensions: 50¹/₄"w x 18¹/₂"d x 13⁷/₈"h

A loop stitch cording traces the perimeter of the bench. Contrasting thread options are available. For thread color options reference CP.1/Stitching on bernhardtdesign.com.

Available in leather, leather alternatives, suede or felt only. Firm, non-flexible leathers not recommended.

SCS Indoor Advantage™ Gold and LEVEL® 2 Certified. See terms and conditions for additional environmental information.

Seat Height	Arm Height	W	D	H	Fabric	Leather	Weight	Cubes/Qty
16 ³ / ₈ "	-	56 ¹ / ₂ "	26 ¹ / ₂ "	16 ³ / ₈ "	3.6 yds	49.0'	60 lbs	17.11/1
416 mm	-	1435 mm	673 mm	416 mm	3.3 m	4.6 sqm	27.3 kg	.48 cu

COM	COL	1	2	4	6	7
3692	3764	4028	4084	4180	4260	4300

cp.1 6505K

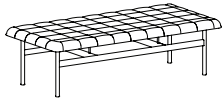

Two-seat bench
Matte black powder coat base
Loop stitch cording
Quilted seat

Base dimensions: 50¼"w x 18½"d x 13⅝"h

A loop stitch cording traces the perimeter of the bench. Contrasting thread options are available. For thread color options reference CP.1/Stitching on bernhardtdesign.com.

Available in leather, leather alternatives, suede or felt only. Firm, non-flexible leathers not recommended.

SCS Indoor Advantage™ Gold and LEVEL® 2 Certified. See terms and conditions for additional environmental information.

Seat Height	Arm Height	W	D	H	Fabric	Leather	Weight	Cubes/Qty
16⅝"	-	56½"	26½"	16⅝"	3.6 yds	49.0'	60 lbs	17.11/1
416 mm	-	1435 mm	673 mm	416 mm	3.3 m	4.6 sqm	27.3 kg	.48 cu

COM	COL	1	2	4	6	7
4015	4087	4351	4407	4503	4583	4623

cp.2 6504/6504B



Ottoman
Upholstered seat

6504 Polished stainless steel base
6504B Brushed stainless steel base

Base dimensions: 23⅝"w x 18¾"d x 13½"h

SCS Indoor Advantage™ Gold and LEVEL® 2 Certified. See terms and conditions for additional environmental information.

Seat Height	Arm Height	W	D	H	Fabric	Leather	Weight	Cubes/Qty
15⅝"	-	26¾"	26½"	15⅝"	2.2 yds	27.0'	31 lbs	11.46/1
403 mm	-	680 mm	559 mm	403 mm	2.0 m	2.5 sqm	14.1 kg	.32 cu

COM	COL	1	2	3	4	5	6	7	8	9	10	11
1472	1516	1678	1712	1732	1771	1805	1820	1844	1878	1908	1942	2137

cp.2 6504K

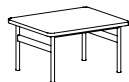

Ottoman
Matte black powder coat base
Upholstered seat

Base dimensions: 23⅝"w x 18¾"d x 13½"h

SCS Indoor Advantage™ Gold and LEVEL® 2 Certified. See terms and conditions for additional environmental information.

Seat Height	Arm Height	W	D	H	Fabric	Leather	Weight	Cubes/Qty
15⅝"	-	26¾"	26½"	15⅝"	2.2 yds	27.0'	31 lbs	11.46/1
403 mm	-	680 mm	559 mm	403 mm	2.0 m	2.5 sqm	14.1 kg	.32 cu

COM	COL	1	2	3	4	5	6	7	8	9	10	11
1634	1678	1840	1874	1894	1933	1967	1982	2006	2040	2070	2104	2299

cp.2 6506/6506B

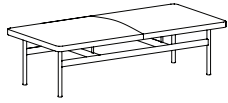

**Two-seat bench
Upholstered seat**

6506 Polished stainless steel base
6506B Brushed stainless steel base

Base dimensions: 50¼"w x 18½"d x 13½"h

SCS Indoor Advantage™ Gold and LEVEL® 1 Certified. See terms and conditions for additional environmental information.

Seat Height	Arm Height	W	D	H	Fabric	Leather	Weight	Cubes/Qty
16⅝"	-	56½"	26½"	16⅝"	3.6 yds	49.0'	60 lbs	17.11'/1
416 mm	-	1435 mm	673 mm	416 mm	3.3 m	4.6 sqm	27.3 kg	.48 cu

COM	COL	1	2	3	4	5	6	7	8	9	10	11
2721	2793	3057	3113	3145	3209	3265	3289	3329	3385	3433	3489	3809

cp.2 6506K

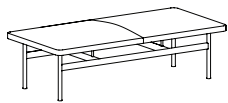

**Two-seat bench
Matte black powder coat base
Upholstered seat**

Base dimensions: 50¼"w x 18½"d x 13½"h

SCS Indoor Advantage™ Gold and LEVEL® 2 Certified. See terms and conditions for additional environmental information.

Seat Height	Arm Height	W	D	H	Fabric	Leather	Weight	Cubes/Qty
16⅝"	-	56½"	26½"	16⅝"	3.6 yds	49.0'	60 lbs	17.11'/1
416 mm	-	1435 mm	673 mm	416 mm	3.3 m	4.6 sqm	27.3 kg	.48 cu

COM	COL	1	2	3	4	5	6	7	8	9	10	11
3042	3114	3378	3434	3466	3530	3586	3610	3650	3706	3754	3810	4130

Elevation Seating and Tables System Specification Guide

Elevation is a modular system of benches, ottomans, and tables that can be used in groupings or as individual products. Benches are available in two and three-seat versions and feature a quilted seat resting on an oak or walnut platform. Metal base options include: an asymmetrical T-leg and a symmetrical fin leg with finish options offered in a bronze metallic or matte black powder coat. Connecting and corner tables are available as an option with benches to create a scalable solution for larger spaces. Tables can be

positioned between or on either end of an Elevation bench. The collection also includes occasional, drum, and multipurpose tables that offer wireless and corded power options.

For additional information on Elevation tables see Bernhardtdesign.com. SCS Indoor Advantage™ Gold and LEVEL® 2 certified. See terms and conditions for additional finish and environmental information.

Elevation System Sample Configurations

Sku Description

Configuration 1



- 3812A** Three-seat asymmetrical bench (2)
- V60** Connecting table (2)
- 3804A** Two-seat symmetrical bench (2)
- V10** Corner Table
- ERL** 60" Round table*

*See Elevation Occasional Price List for more information.

Configuration 2



- 3814A** Three-seat symmetrical bench (2)
- V60** Connecting table (2)
- 3804A** Two-seat symmetrical bench (2)
- V10** Corner table
- 3820A** 21" Ottomans (4)
- DRH** 54" Round table*

*See Elevation Multipurpose Price List for more information.

Configuration 3



- 3812A** Three-seat asymmetrical bench (2)
- XDS** 28" Square drum table (3)*
- 3802A** Two-seat asymmetrical bench (2)
- UDS** 48" Square drum table*

*See Elevation Drum Price List for more information.

For additional information on other products in the collection visit Bernhardtdesign.com.

elevation 3801A/3801AK

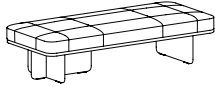

Two-seat bench
Powder coat metal asymmetrical t-leg base
Quilted seat rests on oak platform

3801A Bronze metallic powder coat
3801AK Matte black powder coat

Platform available in all oak finishes. When specifying light finishes the natural characteristics of the wood will be visible and color will vary.

SCS Indoor Advantage™ Gold and LEVEL® 2 certified. See terms and conditions for additional finish and environmental information.

Seat Height	Arm Height	W	D	H	Fabric	Leather	Weight	Cubes/Qty
17½"	-	68"	28"	17½"	3.0 yds	41.0'	155 lbs	32.0'/1
445 mm	-	1727 mm	711 mm	445 mm	2.7 m	3.8 sqm	70.5 kg	.9 cu

COM	COL	1	2	3	4	5	6	7	8	9	10	11
5454	5514	5734	5781	5808	5861	5908	5928	5961	6008	6048	6094	6361

elevation 3802A/3802AK

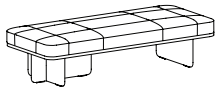

Two-seat bench
Powder coat metal asymmetrical t-leg base
Quilted seat rests on walnut platform

3802A Bronze metallic powder coat
3802AK Matte black powder coat

Platform available in all walnut finishes. When specifying light finishes the natural characteristics of the wood will be visible and color will vary.

SCS Indoor Advantage™ Gold and LEVEL® 2 certified. See terms and conditions for additional finish and environmental information.

Seat Height	Arm Height	W	D	H	Fabric	Leather	Weight	Cubes/Qty
17½"	-	68"	28"	17½"	3.0 yds	41.0'	155 lbs	32.0'/1
445 mm	-	1727 mm	711 mm	445 mm	2.7 m	3.8 sqm	70.5 kg	.9 cu

COM	COL	1	2	3	4	5	6	7	8	9	10	11
5601	5661	5881	5928	5955	6008	6055	6075	6108	6155	6195	6241	6508

elevation 3803A/3803AK

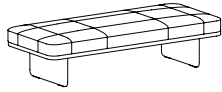

Two-seat bench
Powder coat metal symmetrical fin base
Quilted seat rests on oak platform

3803A Bronze metallic powder coat
3803AK Matte black powder coat

Platform available in all oak finishes. When specifying light finishes the natural characteristics of the wood will be visible and color will vary.

SCS Indoor Advantage™ Gold and LEVEL® 2 certified. See terms and conditions for additional finish and environmental information.

Seat Height	Arm Height	W	D	H	Fabric	Leather	Weight	Cubes/Qty
17½"	-	68"	28"	17½"	3.0 yds	41.0'	142 lbs	32.0'/1
445 mm	-	1727 mm	711 mm	445 mm	2.7 m	3.8 sqm	64.5 kg	.9 cu

COM	COL	1	2	3	4	5	6	7	8	9	10	11
4128	4188	4408	4455	4482	4535	4582	4602	4635	4682	4722	4768	5035

elevation 3804A/3804AK

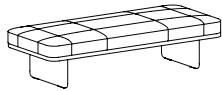

Two-seat bench
Powder coat metal symmetrical fin base
Quilted seat rests on walnut platform

3804A Bronze metallic powder coat
3804AK Matte black powder coat

Platform available in all walnut finishes. When specifying light finishes the natural characteristics of the wood will be visible and color will vary.

SCS Indoor Advantage™ Gold and LEVEL® 2 certified. See terms and conditions for additional finish and environmental information.

Seat Height	Arm Height	W	D	H	Fabric	Leather	Weight	Cubes/Qty
17½"	-	68"	28"	17½"	3.0 yds	41.0'	142 lbs	32.0'/1
445 mm	-	1727 mm	711 mm	445 mm	2.7 m	3.8 sqm	64.5 kg	.9 cu

COM	COL	1	2	3	4	5	6	7	8	9	10	11
4277	4337	4557	4604	4631	4684	4731	4751	4784	4831	4871	4917	5184

elevation 3811A/3811AK

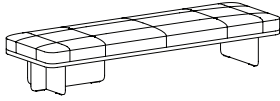

Three-seat bench
Powder coat metal asymmetrical t-leg base
Quilted seat rests on oak platform

3811A Bronze metallic powder coat
3811AK Matte black powder coat

Platform available in all oak finishes. When specifying light finishes the natural characteristics of the wood will be visible and color will vary.

SCS Indoor Advantage™ Gold and LEVEL® 2 certified. See terms and conditions for additional finish and environmental information.

Seat Height	Arm Height	W	D	H	Fabric	Leather	Weight	Cubes/Qty
17½"	-	92"	28"	17½"	3.25 yds	51.0'	232 lbs	42.22/1
445 mm	-	2337 mm	711 mm	445 mm	3.0 m	4.7 sqm	104.5 kg	1.2 cu

COM	COL	1	2	3	4	5	6	7	8	9	10	11
6634	6699	6938	6988	7017	7075	7126	7147	7183	7234	7277	7328	7617

elevation 3812A/3812AK

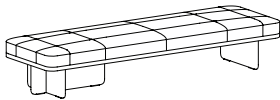

Three-seat bench
Powder coat metal asymmetrical t-leg base
Quilted seat rests on walnut platform

3812A Bronze metallic powder coat
3812AK Matte black powder coat

Platform available in all walnut finishes. When specifying light finishes the natural characteristics of the wood will be visible and color will vary.

SCS Indoor Advantage™ Gold and LEVEL® 2 certified. See terms and conditions for additional finish and environmental information.

Seat Height	Arm Height	W	D	H	Fabric	Leather	Weight	Cubes/Qty
17½"	-	92"	28"	17½"	3.25 yds	51.0'	232 lbs	42.22/1
445 mm	-	2337 mm	711 mm	445 mm	3.0 m	4.7 sqm	104.5 kg	1.2 cu

COM	COL	1	2	3	4	5	6	7	8	9	10	11
6779	6844	7083	7133	7162	7220	7271	7292	7328	7379	7422	7473	7762

elevation 3813A/3813AK

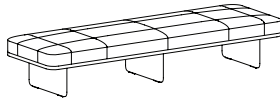

Three-seat bench
Powder coat metal symmetrical fin base
Quilted seat rests on oak platform

3813A Bronze metallic powder coat
3813AK Matte black powder coat

Platform available in all oak finishes. When specifying light finishes the natural characteristics of the wood will be visible and color will vary.

SCS Indoor Advantage™ Gold and LEVEL® 2 certified. See terms and conditions or additional finish and environmental information.

Seat Height	Arm Height	W	D	H	Fabric	Leather	Weight	Cubes/Qty
17½"	-	92"	28"	17½"	3.25 yds	51.0'	196 lbs	42.22/1
445 mm	-	2337 mm	711 mm	445 mm	3.0 m	4.7 sqm	89.1 kg	1.2 cu

COM	COL	1	2	3	4	5	6	7	8	9	10	11
5307	5372	5611	5661	5690	5748	5799	5820	5856	5907	5950	6001	6290

elevation 3814A/3814AK

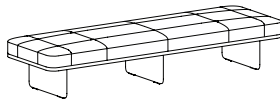

Three-seat bench
Powder coat metal symmetrical fin base
Quilted seat rests on walnut platform

3814A Bronze metallic powder coat
3814AK Matte black powder coat

Platform available in all walnut finishes. When specifying light finishes the natural characteristics of the wood will be visible and color will vary.

SCS Indoor Advantage™ Gold and LEVEL® 2 certified. See terms and conditions for additional finish and environmental information.

Seat Height	Arm Height	W	D	H	Fabric	Leather	Weight	Cubes/Qty
17½"	-	92"	28"	17½"	3.25 yds	51.0'	196 lbs	42.22/1
445 mm	-	2337 mm	711 mm	445 mm	3.0 m	4.7 sqm	89.1 kg	1.2 cu

COM	COL	1	2	3	4	5	6	7	8	9	10	11
5454	5519	5758	5808	5837	5895	5946	5967	6003	6054	6097	6148	6437

elevation 3820A



**Ottoman
Fully upholstered**

Quilted seat
Non-marring glides

SCS Indoor Advantage™ Gold and LEVEL® 2 certified. See terms and conditions for additional environmental information.

Seat Height	Arm Height	W	D	H	Fabric	Leather	Weight	Cubes/Qty
17"	-	21"	21"	17"	2.0 yds	31.0'	36 lbs	5.88'/1
435 mm	-	533 mm	533 mm	432 mm	1.8 m	2.9 sqm	16.4 kg	.17 cu

COM	COL	1	2	3	4	5	6	7	8	9	10	11
1257	1297	1444	1475	1493	1529	1560	1573	1595	1626	1653	1684	1862

elevation 3820AM



**Mobile ottoman
Fully upholstered**

Quilted seat
Casters

SCS Indoor Advantage™ Gold and LEVEL® 2 certified. See terms and conditions for additional environmental information.

Seat Height	Arm Height	W	D	H	Fabric	Leather	Weight	Cubes/Qty
17"	-	21"	21"	17½"	2.0 yds	31.0'	36 lbs	5.88'/1
435 mm	-	533 mm	533 mm	435 mm	1.8 m	2.9 sqm	16.4 kg	.17 cu

COM	COL	1	2	3	4	5	6	7	8	9	10	11
1366	1406	1553	1584	1602	1638	1669	1682	1704	1735	1762	1793	1971

elevation 3821A

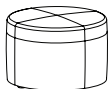

**Ottoman
Fully upholstered**

Quilted seat
Non-marring glides

SCS Indoor Advantage™ Gold and LEVEL® 2 certified. See terms and conditions for additional environmental information.

Seat Height	Arm Height	W	D	H	Fabric	Leather	Weight	Cubes/Qty
17"	-	25"	25"	17"	2.25 yds	36.0'	44 lbs	12.5'/1
435 mm	-	635 mm	635 mm	432 mm	2.1 m	3.3 sqm	20.0 kg	.35 cu

COM	COL	1	2	3	4	5	6	7	8	9	10	11
1550	1595	1760	1795	1815	1855	1890	1905	1930	1965	1995	2030	2230

elevation 3821AM

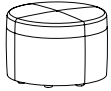

**Mobile ottoman
Fully upholstered**

Quilted seat
Casters

SCS Indoor Advantage™ Gold and LEVEL® 2 certified. See terms and conditions for additional environmental information.

Seat Height	Arm Height	W	D	H	Fabric	Leather	Weight	Cubes/Qty
17½"	-	25"	25"	17½"	2.25 yds	36.0'	44 lbs	12.5'/1
435 mm	-	635 mm	635 mm	435 mm	2.1 m	3.3 sqm	20.0 kg	12.5'/1

COM	COL	1	2	3	4	5	6	7	8	9	10	11
1661	1706	1871	1906	1926	1966	2001	2016	2041	2076	2106	2141	2341

elevation 3822A

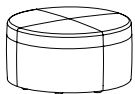

**Ottoman
Fully upholstered**

Quilted seat
Non-marring glides

SCS Indoor Advantage™ Gold and LEVEL® 2 certified. See terms and conditions for additional environmental information.

Seat Height	Arm Height	W	D	H	Fabric	Leather	Weight	Cubes/Qty
16"	-	31"	31"	16"	2.75 yds	37.5'	41 lbs	13.86'/1
406 mm	-	787 mm	787 mm	406 mm	2.5 m	3.5 sqm	18.6 kg	.4 cu

COM	COL	1	2	3	4	5	6	7	8	9	10	11
1844	1899	2101	2144	2168	2217	2260	2278	2309	2352	2388	2431	2676

elevation 3823A

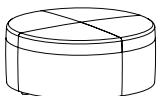

**Ottoman
Fully upholstered**

Quilted seat
Non-marring glides

SCS Indoor Advantage™ Gold and LEVEL® 2 certified. See terms and conditions for additional environmental information.

Seat Height	Arm Height	W	D	H	Fabric	Leather	Weight	Cubes/Qty
16"	-	37"	37"	16"	4.0 yds	64.0'	57 lbs	79.09'/1
406 mm	-	940 mm	940 mm	406 mm	2.5 m	5.9 sqm	25.9 kg	2.2 cu

COM	COL	1	2	3	4	5	6	7	8	9	10	11
2140	2220	2514	2576	2612	2683	2745	2772	2816	2878	2932	2994	3349

Elevation System Tables

Connecting and corner tables are available as an option with benches to create a scalable solution for larger spaces. The tables are designed to be used with Elevation benches only and can be positioned between or on either end of a bench. Tops are available in solid laminate - 671, oak, walnut and glacier white Corian®. Metal symmetrical fin base available in bronze metallic and matte black powder coat. **For use with Elevation benches only.**

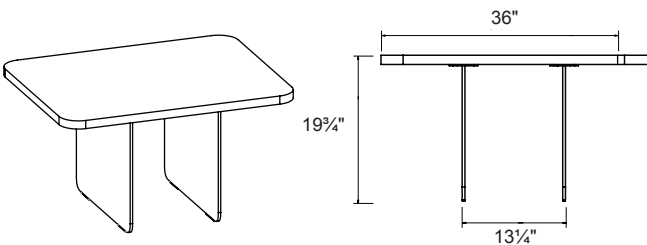
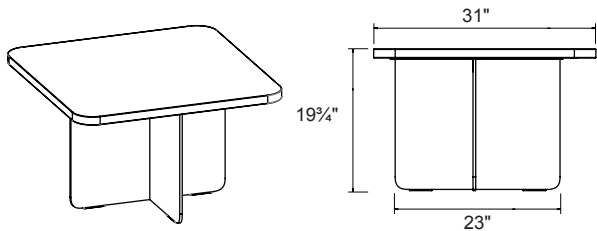

Finish Selection

When specifying light finishes the natural characteristics of the wood will be visible and color will vary.

Oak Veneer

Standard Finish	
805	860
836	861
837	865
839	866
840	870
845	

Walnut

Standard Finish	
823	861
839	866
841	870
860	

Veneer Selection

Oak Veneer

Order Code - C
Rift Cut, Slip Matched

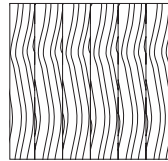

Walnut Veneer

Order Code - 9
Quarter Cut, Slip Matched

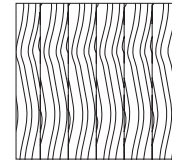

Laminate Selections

Order Code - F
Designer White

Standard Finish
671 Wilsonart D354-60

Corian®

Order Code - 8
Glacier White

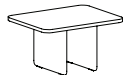
	description	sku	w	d	h	weight	solid laminate	oak	walnut	corian
	corner table for use with elevation benches only	V10	31	31	19π	165	\$ 3097	\$ 3243	\$ 3391	\$ 5454
	connecting table for use with elevation benches only	V60	36	28	19π	106	2360	2508	2657	4717

specification codes

series

T

sku

|||

base

M metal
M

base finish

Z bronze metallic powder coat
3 matte black powder coat

top

F white laminate - 671
C oak
9 walnut
8 corian® - glacier white

top finish

see above
|||

gallery 5281



Ottoman
Fully upholstered
Saddle stitched

Non-marring glides
 Standard with welt

When using a combination of fabrics or leathers, specify the application by designating the appropriate letter, shown below, on the purchase order. Yardage shown must be used.

See terms and conditions for contrasting upholstery and welt upcharges.

- A) One fabric or leather for top seat panel and upper body
 yardage: 2.0 yds leather: 36.0 sq. ft.
- B) One fabric or leather for lower body
 yardage: 1.0 yds. leather: 18.0 sq. ft.
- C) One fabric or leather for welt
 yardage: 1.0 yds. leather: 18.0 sq. ft.

SCS Indoor Advantage™ Gold and LEVEL® 2 Certified. See terms and conditions for additional environmental information.

Seat Height	Arm Height	W	D	H	Fabric	Leather	Weight	Cubes/Qty
17"	-	21"	21"	17"	3.0 yds	53.0'	25 lbs.	5.88'/1
432 mm	-	533 mm	533 mm	432 mm	2.7 m	4.9 sqm	11.3 kg	.17 cu

COM	COL	1	2	3	4	5	6	7	8	9	10	11
1045	1105	1325	1372	1399	1452	1499	1519	1552	1599	1639	1685	1952

gallery 5281M



Mobile ottoman
Fully upholstered
Saddle stitched

Six small concealed casters
 Standard with welt

When using a combination of fabrics or leathers, specify the application by designating the appropriate letter, shown below, on the purchase order. Yardage shown must be used.

See terms and conditions for contrasting upholstery and welt upcharges.

- A) One fabric or leather for top seat panel and upper body
 yardage: 2.0 yds. leather: 36.0 sq. ft.
- B) One fabric or leather for lower body
 yardage: 1.0 yds. leather: 18.0 sq. ft.
- C) One fabric or leather for welt
 yardage: 1.0 yds. leather: 18.0 sq. ft.

SCS Indoor Advantage™ Gold and LEVE® 2 Certified. See terms and conditions for additional environmental information.

Seat Height	Arm Height	W	D	H	Fabric	Leather	Weight	Cubes/Qty
17"	-	21"	21"	17"	3.0 yds	53.0'	25 lbs.	5.88'/1
432 mm	-	533 mm	533 mm	432 mm	2.7 m	4.9 sqm	11.3 kg	.17 cu

COM	COL	1	2	3	4	5	6	7	8	9	10	11
1149	1209	1429	1476	1503	1556	1603	1623	1656	1703	1743	1789	2056

gallery 5282

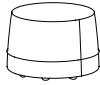

Ottoman
Fully upholstered
Saddled stitched

Non-marring glides
 Standard with welt

When using a combination of fabrics or leathers, specify the application by designating the appropriate letter, shown below, on the purchase order. Yardage shown must be used.

See terms and conditions for contrasting upholstery and welt upcharges.

- A) One fabric or leather for top seat panel and upper body
 yardage: 2.0 yds. leather: 36.0 sq. ft.
- B) One fabric or leather for lower body
 yardage: 1.0 yds. leather: 18.0 sq. ft.
- C) One fabric or leather for welt
 yardage: 1.0 yds. leather: 18.0 sq. ft.

SCS Indoor Advantage™ Gold and LEVEL® 2 Certified. See terms and conditions for additional environmental information.

Seat Height	Arm Height	W	D	H	Fabric	Leather	Weight	Cubes/Qty
17"	-	25"	25"	17"	3.0 yds	53.0	33 lbs.	13.86'/1
432 mm	-	635 mm	635 mm	432 mm	2.7 m	4.9 sqm	15.0 kg	.40 cu

COM	COL	1	2	3	4	5	6	7	8	9	10	11
1220	1280	1500	1547	1574	1627	1674	1694	1727	1774	1814	1860	2127

gallery 5282M

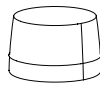

Mobile ottoman
Fully upholstered
Saddle stitched

Six small concealed casters
 Standard with welt

When using a combination of fabrics or leathers, specify the application by designating the appropriate letter, shown below, on the purchase order. Yardage shown must be used.

See terms and conditions for contrasting upholstery and welt upcharges.

- A) One fabric or leather for top seat panel and upper body
 yardage: 2.0 yds. leather: 36.0 sq. ft.
- B) One fabric or leather for lower body
 yardage: 1.0 yds. leather: 18.0 sq. ft.
- C) One fabric or leather for welt
 yardage: 1.0 yds. leather: 18.0 sq. ft.

SCS Indoor Advantage™ Gold and LEVEL® 2 Certified. See terms and conditions for additional environmental information.

Seat Height	Arm Height	W	D	H	Fabric	Leather	Weight	Cubes/Qty
17"	-	25"	25"	17"	3.0 yds	53.0	33 lbs.	13.86'/1
432 mm	-	635 mm	635 mm	432 mm	2.7 m	4.9 sqm	15.0 kg	.40 cu

COM	COL	1	2	3	4	5	6	7	8	9	10	11
1323	1383	1603	1650	1677	1730	1777	1797	1830	1877	1917	1963	2230

gallery 5283

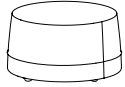

Ottoman
Fully upholstered
Saddle stitched

Non-marring glides
 Standard with welt

When using a combination of fabrics or leathers, specify the application by designating the appropriate letter, shown below, on the purchase order. Yardage shown must be used.

See terms and conditions for contrasting upholstery and welt upcharges.

- A) One fabric or leather for top seat panel and upper body
 yardage: 2.0 yds. leather: 36.0 sq. ft.
- B) One fabric or leather for lower body
 yardage: 1.25 yds. leather: 36.0 sq. ft.
- C) One fabric or leather for welt
 yardage: 1.25 yds. leather: 32.0 sq. ft.

SCS Indoor Advantage™ Gold and LEVEL® 2 Certified. See terms and conditions for additional environmental information.

Seat Height	Arm Height	W	D	H	Fabric	Leather	Weight	Cubes/Qty
17"	-	31"	31"	17"	4.75 yds.	82.0'	43 lbs.	13.86'/1
432	-	788 mm	788 mm	432 mm	4.3 m	7.6 sqm	20 kg	.40 cu

COM	COL	1	2	3	4	5	6	7	8	9	10	11
1463	1558	1907	1981	2023	2107	2181	2213	2266	2340	2403	2477	2899

gallery 5284



Ottoman
Fully upholstered
Saddle stitched

Non-marring glides
 Standard with welt

When using a combination of fabrics or leathers, specify the application by designating the appropriate letter, shown below, on the purchase order. Yardage shown must be used.

See terms and conditions for contrasting upholstery and welt upcharges.

- A) One fabric or leather for top seat panel and upper body
 yardage: 2.0 yds. leather: 36.0 sq. ft.
- B) One fabric or leather for lower body
 yardage: 1.25 yds. leather: 36.0 sq. ft.
- C) One fabric or leather for welt
 yardage: 1.25 yds. leather: 32.0 sq. ft.

SCS Indoor Advantage™ Gold and LEVEL® 2 Certified. See terms and conditions for additional environmental information.

Seat Height	Arm Height	W	D	H	Fabric	Leather	Weight	Cubes/Qty
17"	-	37"	37"	17"	4.75 yds.	86.0'	64 lbs.	19.36'/1
432 mm	-	940 mm	940 mm	432 mm	4.3 m	8.0 sqm	29 kg	.55 cu

COM	COL	1	2	3	4	5	6	7	8	9	10	11
1776	1871	2220	2294	2336	2420	2494	2526	2579	2653	2716	2790	3212

gallery 5291



Bench
Fully upholstered
Saddle stitched

Non-marring glides

When using a combination of fabrics or leathers, specify the application by designating the appropriate letter, shown below, on the purchase order. Yardage shown must be used.

See terms and conditions for contrasting upholstery and welt upcharges.

- A) One fabric or leather for top seat panel and upper body
 yardage: 2.0 yds. leather: 36.0 sq. ft.
- B) One fabric or leather for lower body
 yardage: 1.0 yds. leather: 18.0 sq. ft.
- C) One fabric or leather for welt
 yardage: 1.0 yds. leather: 18.0 sq. ft.

SCS Indoor Advantage™ Gold and LEVEL® 2 Certified. See terms and conditions for additional environmental information.

Seat Height	Arm Height	W	D	H	Fabric	Leather	Weight	Cubes/Qty
17"	-	22"	19"	17"	2.5 yds	44.0'	30 lbs.	5.88'/1
432 mm	-	559 mm	483 mm	432 mm	2.3 m	4.1 sqm	14.0 kg	.27 cu

COM	COL	1	2	3	4	5	6	7	8	9	10	11
1045	1095	1279	1318	1340	1384	1423	1440	1468	1507	1540	1579	1801

gallery 5291M



Mobile bench
Fully upholstered
Saddle stitched

Four small concealed casters

When using a combination of fabrics or leather, specify the application by designating the appropriate letter, shown below, on the purchase order. Yardage shown must be used.

See terms and conditions for contrasting upholstery and welt upcharges.

- A) One fabric or leather for top seat panel and upper body
 yardage: 2.0 yds. leather: 36.0 sq. ft.
- B) One fabric or leather for lower body
 yardage: 1.0 yds. leather: 18.0 sq. ft.
- C) One fabric or leather for welt
 yardage: 1.0 yds. leather: 18.0 sq. ft.

SCS Indoor Advantage™ Gold and LEVEL® 2 Certified. See terms and conditions for additional environmental information.

Seat Height	Arm Height	W	D	H	Fabric	Leather	Weight	Cubes/Qty
17"	-	22"	19"	17"	2.5 yds	44.0'	30 lbs.	5.88'/1
432 mm	-	559 mm	483 mm	432 mm	2.3 m	4.1 sqm	14.0 kg	.27 cu

COM	COL	1	2	3	4	5	6	7	8	9	10	11
1149	1199	1383	1422	1444	1488	1527	1544	1572	1611	1644	1683	1905

gallery 5295

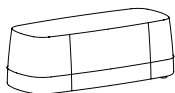

**Two-seat bench
Fully upholstered
Saddle stitched**

Non-marring glides
Standard with welt

When using a combination of fabrics or leathers, specify the application by designating the appropriate letter, shown below, on the purchase order. Yardage shown must be used.

See terms and conditions for contrasting upholstery and welt upcharges.

- A) One fabric or leather for top seat panel and upper body
yardage: 2.25 yds. leather: 39.0 sq. ft.
- B) One fabric or leather for lower body
yardage: 1.25 yds. leather: 18.0 sq. ft.
- C) One fabric or leather for welt
yardage: 1.0 yds. leather: 18.0 sq. ft.

SCS Indoor Advantage™ Gold and LEVEL® 2 Certified. See terms and conditions for additional environmental information.

Seat Height	Arm Height	W	D	H	Fabric	Leather	Weight	Cubes/Qty
17"	-	48 1/8"	20 3/4"	17"	2.8 yds	50.0'	66 lbs.	29.75'/1
432 mm	-	1222 mm	527 mm	432 mm	2.6 m	4.6 sqm	30 kg	.84 cu

COM	COL	1	2	3	4	5	6	7	8	9	10	11
1776	1832	2038	2081	2106	2156	2200	2218	2249	2293	2330	2374	2623

gallery 5295M

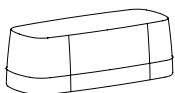

**Two-seat mobile bench
Fully upholstered
Saddle stitched**

Six small concealed casters
Standard with welt

When using a combination of fabrics or leathers, specify the application by designating the appropriate letter, shown below, on the purchase order. Yardage shown must be used.

See terms and conditions for contrasting upholstery and welt upcharges.

- A) One fabric or leather for top seat panel and upper body
yardage: 2.25 yds. leather: 39.0 sq. ft.
- B) One fabric or leather for lower body
yardage: 1.25 yds. leather: 18.0 sq. ft.
- C) One fabric or leather for welt
yardage: 1.0 yds. leather: 18.0 sq. ft.

SCS Indoor Advantage™ Gold and LEVEL® 2 Certified. See terms and conditions for additional environmental information.

Seat Height	Arm Height	W	D	H	Fabric	Leather	Weight	Cubes/Qty
17"	-	48 1/8"	20 3/4"	17"	2.8 yds	50.0'	66 lbs.	29.75'/1
432 mm	-	1222 mm	527 mm	432 mm	2.6 m	4.6 sqm	30 kg	.84 cu

COM	COL	1	2	3	4	5	6	7	8	9	10	11
1947	2003	2209	2252	2277	2327	2371	2389	2420	2464	2501	2545	2794

gallery 5297

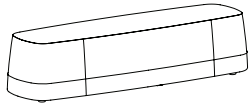

**Three-seat bench
Upholstered
Saddle stitched**

Non-marring glides
Standard with welt

When using a combination of fabrics or leathers, specify the application by designating the appropriate letter, shown below, on the purchase order. Yardage shown must be used.

See terms and conditions for contrasting upholstery and welt upcharges.

- A) One fabric or leather for top seat panel and upper body
yardage: 3.0 yds. leather: 49.0 sq. ft.
- B) One fabric or leather for lower body
yardage: 1.75 yds. leather: 18.0 sq. ft.
- C) One fabric or leather for welt
yardage: 1.0 yds. leather: 18.0 sq. ft.

SCS Indoor Advantage™ Gold and LEVEL® 2 Certified. See terms and conditions for additional environmental information.

Seat Height	Arm Height	W	D	H	Fabric	Leather	Weight	Cubes/Qty
17"	-	72"	21"	17"	3.8 yds	66.0'	105 lbs.	37.62'/1
432 mm	-	1829 mm	533 mm	432 mm	3.5 m	6.1 sqm	48 kg	1.07 cu

COM	COL	1	2	3	4	5	6	7	8	9	10	11
2295	2371	2650	2709	2743	2811	2870	2895	2937	2996	3047	3106	3444

gallery 5297M

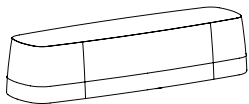

**Three-seat mobile bench
Fully upholstered
Saddle stitched**

Eight small concealed casters
Standard with welt

When using a combination of fabrics or letters, specify the application by designating the appropriate letter, shown below, on the purchase order. Yardage shown must be used.

See terms and conditions for contrasting upholstery and welt upcharges.

- A) One fabric or leather for top seat panel and upper body
yardage: 3.0 yds. leather: 49.0 sq. ft.
- B) One fabric or leather for lower body
yardage: 1.75 yds. leather: 18.0 sq. ft.
- C) One fabric or leather for welt
yardage: 1.0 yds. leather: 18.0 sq. ft.

SCS Indoor Advantage™ Gold and LEVEL® 2 Certified. See terms and conditions for additional environmental information.

Seat Height	Arm Height	W	D	H	Fabric	Leather	Weight	Cubes/Qty
17"	-	72"	21"	17"	3.8 yds	66.0'	105 lbs.	37.62'/1
432 mm	-	1829 mm	533 mm	432 mm	3.5 m	6.1 sqm	48 kg	1.07 cu

COM	COL	1	2	3	4	5	6	7	8	9	10	11
2400	2476	2755	2814	2848	2916	2975	3000	3042	3101	3152	3211	3549

Luca Benches

Standard Features



The Luca bench collection offers a series of round and rectangular benches that can be used as freestanding or interchangeably with product from the Luca modular seating system. Select benches feature end tables that are available in oak or walnut and are offered with and without power. Legs are available in one of three finishes: polished aluminum, matte black powder coat and satin white powder coat.

Luca benches are part of the Luca modular seating system that is comprised of 41 unique modules. Options include freestanding benches, two-seat and three-seat modules, corner modules and seating and bench modules with end tables.

Luca is fully upholstered with 5/8" diameter non-marring adjustable nylon glides. When ordering configurations, please provide the total COM yardage from the same dye lot in a continuous roll(s). All COM/COL fabrics must be preapproved by Bernhardt Design prior to application. SCS Indoor Advantage™ Gold and LEVEL® 2 certified.

Configurations are connected by a ganging bracket. Ganging brackets are sold separately and will ship with product. See the Luca bench accessories page for ordering information.

Please visit BernhardtDesign.com for a complete library of 2D, 3D and Revit models. You may also contact your local sales representative or the Bernhardt Design corporate office for specification assistance.

Leg Options

Polished Aluminum - 6



Matte Black Powder Coat- 3



Satin White Powder Coat- W



Luca Bench Options



Veneer Selections

OAK Oak
Order Code - C
Rift Cut

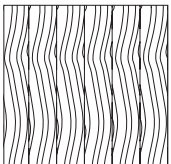

WLT Walnut
Order Code - 9
Flat Cut

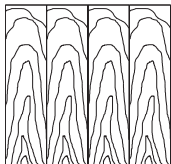

A three-character sku identifies each wood veneer option as well as standard finishes. Base and top finishes are specified separately. When specifying light finishes the natural characteristics of the wood will be visible and color will vary. Therefore, exact color matches are not possible.

OAK Oak

Standard Finish
871 860 870
837 836 861
865 805 866
872 839 845

WLT Walnut

Standard Finish
872 861
860 823
839 866
870

Standard Finish
M73 M71 M75
M74 M76 M77

Edge Profile

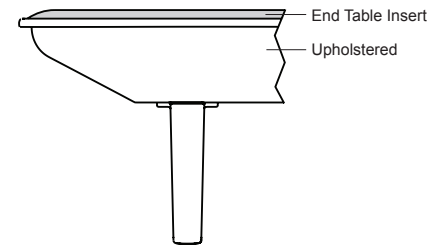

Surface Mount Power Modules

Luca offers a proprietary surface mount power solution which is installed flush to the worksurface and provides (2) 15 amp receptacles, (1) 2 amp USB-A port and (1) 2 amp USB-C port. The unit has a 10' infeed with a grounded plug. Power module finish is determined by leg finish selection.



Power Module
Black Finish

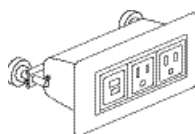

(2) 120 v 60 Hz. 15 amp receptacles
(1) 2 amp USB-A port, 10 watt
(1) 2 amp USB-C port, 20 watt
6½" w x 3" d x 2¾" h

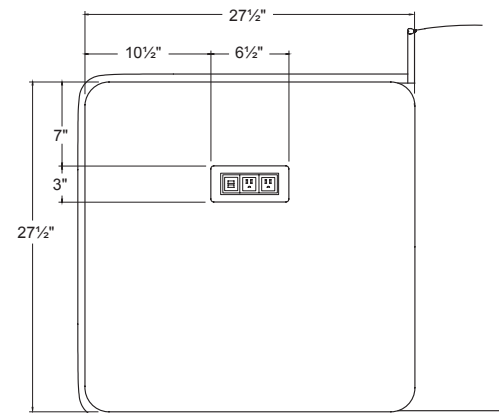

Connecting Modules



Luca modules connect by attaching a ganging bracket to the underside of the furniture. Order one ganging bracket per point of connection of modular units. Ganging brackets are sold separately and will ship with product.

To connect the modules together insert the three fasteners into the inserts at the location each module is desired to be connected. Push modules together in desired location.

Leave 1/4" between head of fastener and upholstery. Fit bracket over heads of fasteners and slide bracket to lock fasteners into keyhole slots cut into fastener. Tighten fasteners against bracket.

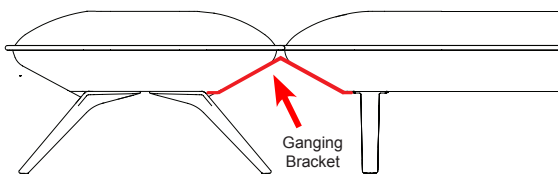

Ganging bracket is concealed behind flange and is not visible when looking at the sofa.

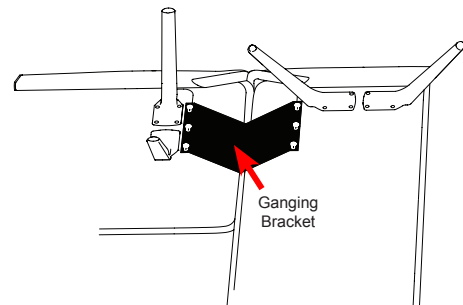

Under side view of the ganging bracket placement

luca 8D36D



36" Round bench
Freestanding
Polished aluminum or powder coat legs
Upholstered

SCS Indoor Advantage™ Gold and LEVEL® 2 certified. See terms and conditions for instructions for additional environmental information.

Seat Height	Arm Height	W	D	H	Fabric	Leather	Weight	Cubes/Qty
16½"	-	36"	36"	16½"	3.0 yds.	49.0'	68 lbs.	19.4'/1
419 mm	-	914 mm	914 mm	419 mm	2.7 m	4.6 sqm	30.8 kg	0.55 cu.

COM	COL	1	2	3	4	5	6	7	8	9	10	11
1947	2007	2227	2274	2301	2354	2401	2421	2454	2501	2541	2587	2854

luca 8D42D



42" Round bench
Freestanding
Polished aluminum or powder coat legs
Upholstered

SCS Indoor Advantage™ Gold and LEVEL® 2 certified. See terms and conditions for instructions for additional environmental information.

Seat Height	Arm Height	W	D	H	Fabric	Leather	Weight	Cubes/Qty
16½"	-	42"	42"	16½"	3.5 yds.	57.0'	90 lbs.	25.72'/1
419 mm	-	1067 mm	1067 mm	419 mm	3.2 m	5.3 sqm	40.8 kg	.72 cu.

COM	COL	1	2	3	4	5	6	7	8	9	10	11
2225	2295	2552	2607	2638	2700	2754	2778	2817	2871	2918	2972	3283

sku

--	--	--	--	--	--	--	--	--	--	--	--	--	--

frame finish

- 6** polished aluminum standard, OR
- specify powder coat, upcharge \$150*
- 3** matte black powder coat
- W** satin white powder coat

luca 8D48D

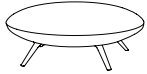

48" Round bench
Freestanding
Polished aluminum or powder coat legs
Upholstered

SCS Indoor Advantage™ Gold and LEVEL® 2 certified. See terms and conditions for additional environmental information.

Seat Height	Arm Height	W	D	H	Fabric	Leather	Weight	Cubes/Qty
16½"	-	48"	48"	16½"	5.75 yds.	95.0'	109 lbs.	32.86'/1
419 mm	-	1219 mm	1219mm	419 mm	5.3 m	8.2 sqm	49.4 kg	.93 cu.

COM	COL	1	2	3	4	5	6	7	8	9	10	11
2505	2620	3042	3132	3183	3285	3374	3413	3477	3566	3643	3732	4243

luca 8D60D



60" Round bench
Freestanding
Polished aluminum powder coat legs
Upholstered

SCS Indoor Advantage™ Gold and LEVEL® 2 certified. See terms and conditions for additional environmental information.

Seat Height	Arm Height	W	D	H	Fabric	Leather	Weight	Cubes/Qty
16 ½"	-	60"	60"	16½"	6.3 yds.	103.0'	148 lbs.	49.78'/1
419 mm	-	1524 mm	1524 mm	419 mm	5.8 m	9.6 sqm	67.1 kg	1.40 cu.

COM	COL	1	2	3	4	5	6	7	8	9	10	11
3061	3187	3649	3747	3803	3915	4013	4055	4125	4223	4307	4405	4965

sku

--	--	--	--	--	--	--	--	--	--	--	--	--	--	--

frame finish

- 6** polished aluminum standard, OR
- specify powder coat, upcharge \$150*
- 3** matte black powder coat
- W** satin white powder coat

luca 8D01N



Module bench
Polished aluminum or powder coat legs
Upholstered

Ganging brackets are sold separately and will ship with the product. See Luca accessories page to order brackets.

SCS Indoor Advantage™ Gold and LEVEL® 2 certified. See terms and conditions for additional environmental information.

Seat Height	Arm Height	W	D	H	Fabric	Leather	Weight	Cubes/Qty
16½"	-	45¼"	28¾"	16½"	3.5 yds.	57.0'	78 lbs.	25.67'/1
419 mm	-	1149 mm	730 mm	419 mm	3.2 m	5.3 sqm	35.4 kg	.73 cu.

COM	COL	1	2	3	4	5	6	7	8	9	10	11
1809	1879	2136	2191	2222	2284	2338	2362	2401	2455	2502	2556	2867

luca 8D05N

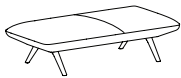

Two-seat module bench
Polished aluminum or powder coat legs
Upholstered

Ganging brackets are sold separately and will ship with the product. See Luca accessories page to order brackets.

SCS Indoor Advantage™ Gold and LEVEL® 2 certified. See terms and conditions for additional environmental information.

Seat Height	Arm Height	W	D	H	Fabric	Leather	Weight	Cubes/Qty
16½"	-	58½"	28¾"	16½"	5 yds.	81.0'	91 lbs.	25.67'/1
419 mm	-	1486 mm	730 mm	419 mm	4.6 m	7.5 sqm	41.3 kg	.73 cu.

COM	COL	1	2	3	4	5	6	7	8	9	10	11
2225	2325	2692	2770	2814	2903	2981	3014	3070	3148	3214	3292	3737

sku

--	--	--	--	--	--	--	--	--	--	--	--	--

frame finish

- 6** polished aluminum standard, OR
- specify powder coat, upcharge \$150
- 3** matte black powder coat
- W** satin white powder coat

--

luca 8D07N

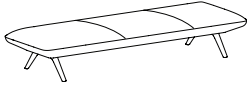

Three-seat module bench
Polished aluminum or powder coat legs
Upholstered

Ganging brackets are sold separately and will ship with the product. See Luca accessories page to order brackets.

SCS Indoor Advantage™ Gold and LEVEL® 2 certified. See terms and conditions for additional environmental information.

Seat Height	Arm Height	W	D	H	Fabric	Leather	Weight	Cubes/Qty
16½"	-	87¼"	28¾"	16½"	7.25 yds.	118.0'	121 lbs	37.6'/1
419 mm	-	2216 mm	730 mm	419 mm	6.6 m	11.0 sqm	54.9 kg	1.10 cu.

COM	COL	1	2	3	4	5	6	7	8	9	10	11
2642	2787	3319	3432	3496	3625	3738	3786	3867	3980	4076	4189	4834

luca 8D02N

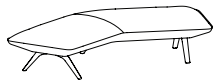

45° Modular bench
Polished aluminum or powder coat legs
Upholstered

Ganging brackets are sold separately and will ship with the product. See Luca accessories page to order brackets.

SCS Indoor Advantage™ Gold and LEVEL® 2 certified. See terms and conditions for additional environmental information.

Seat Height	Arm Height	W	D	H	Fabric	Leather	Weight	Cubes/Qty
16½"	-	80½"	40¼"	16½"	4.75 yds.	78.0'	119 lbs.	45.45'/1
419 mm	-	2045 mm	1022 mm	419 mm	4.3 m	7.2 sqm	54.0 kg	1.30 cu.

COM	COL	1	2	3	4	5	6	7	8	9	10	11
2642	2737	3086	3160	3202	3286	3360	3392	3445	3519	3582	3656	4078

sku

frame finish

--	--	--	--	--	--	--	--	--	--	--	--	--

- 6** polished aluminum standard, OR
- specify powder coat, upcharge \$150
- 3** matte black powder coat
- W** satin white powder coat

luca 8D09N

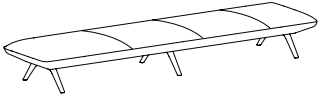

Four-seat module bench
Polished aluminum or powder coat legs
Upholstered

Ganging brackets are sold separately and will ship with product. See Luca accessories page to order brackets

SCS Indoor Advantage™ Gold and LEVEL® 2 certified. See terms and conditions for additional environmental information.

Seat Height	Arm Height	W	D	H	Fabric	Leather	Weight	Cubes/Qty
16½"	-	117"	28¾"	16½"	9.5 yds.	154.0'	159 lbs.	50.0'/1
419 mm	-	2972 mm	730 mm	419 mm	8.7 m	14.3 sqm	72.1 kg	1.40 cu.

COM	COL	1	2	3	4	5	6	7	8	9	10	11
3338	3528	4225	4373	4457	4626	4774	4837	4943	5091	5217	5365	6210

sku	frame finish
<input type="checkbox"/> <input type="checkbox"/> <input type="checkbox"/> <input type="checkbox"/> <input type="checkbox"/>	6 polished aluminum standard, OR specify powder coat, upcharge \$200 3 matte black powder coat W satin white powder coat

luca 8D06N

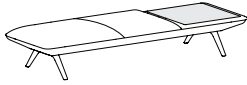

Two-seat bench with end table
Polished aluminum or powder coat legs
Upholstered

End table available in all oak and walnut finishes. When specifying light finish the natural characteristics of the wood will be visible and color will vary.

Ganging brackets are sold separately and will ship with the product. See Luca accessories page to order brackets.

SCS Indoor Advantage™ Gold and LEVEL® 2 certified. See terms and conditions for additional finish and environmental information.

Seat Height	Arm Height	W	D	H	Fabric	Leather	Weight	Cubes/Qty
16½"	-	86¼"	28¾"	16½"	6.75 yds.	110.0'	140 lbs.	37.6'/1
419 mm	-	2191 mm	730 mm	419 mm	6.2 m	10.2 sqm	63.5 kg	1.10 cu.

COM	COL	1	2	3	4	5	6	7	8	9	10	11
3198	3333	3828	3933	3993	4113	4218	4263	4338	4443	4533	4638	5238

luca 8P06N

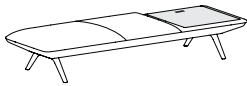

Power
Two-seat bench with end table
Polished aluminum or powder coat legs
Upholstered

End table available in all oak and walnut finishes. When specifying light finish the natural characteristics of the wood will be visible and color will vary.

Ganging brackets are sold separately and will ship with the product. See Luca accessories page to order brackets.

Power: Surface mount power provides (2) 15 amp receptacles, (1) 2 amp USB-A port, 10 watt and (1) 2 amp USB-C port, 20 watt.

SCS Indoor Advantage™ Gold and LEVEL® 2 certified. See terms and conditions for additional finish and environmental information.

Seat Height	Arm Height	W	D	H	Fabric	Leather	Weight	Cubes/Qty
16½"	-	86¼"	28¾"	16½"	6.75 yds.	110.0'	143 lbs.	37.6'/1
419 mm	-	2191 mm	730 mm	419 mm	6.2 m	10.2 sqm	64.9 kg	1.10 cu.

COM	COL	1	2	3	4	5	6	7	8	9	10	11
3963	4098	4593	4698	4758	4878	4983	5028	5103	5208	5298	5403	6003

sku	frame finish	run-off top species	wood top finish
	6 polished aluminum standard, OR specify powder coat, upcharge \$150 3 matte black powder coat W satin white powder coat	C oak 9 walnut	see seating finishes

luca 8D08N

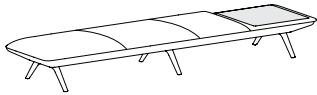

Three-seat bench with end table
Polished aluminum or powder coat legs
Upholstered

End table available in all oak and walnut finishes. When specifying light finish the natural characteristics of the wood will be visible and color will vary.

Ganging brackets are sold separately and will ship with the product. See Luca accessories page to order brackets.

SCS Indoor Advantage™ Gold and LEVEL® 2 certified. See terms and conditions for additional finish and environmental information.

Seat Height	Arm Height	W	D	H	Fabric	Leather	Weight	Cubes/Qty
16½"	-	115¼"	28¾"	16½"	8.5 yds.	140.0'	178 lbs.	50.0'/1
419 mm	-	2921 mm	730 mm	419 mm	7.8 m	13.0 sqm	80.7 kg	1.40 cu.

COM	COL	1	2	3	4	5	6	7	8	9	10	11
3755	3925	4549	4681	4757	4908	5040	5097	5191	5323	5437	5569	6324

luca 8P08N

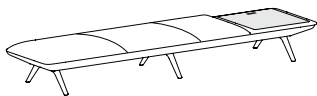

Power
Three-seat bench with end table
Polished aluminum or powder coat legs
Upholstered

End table available in all oak and walnut finishes. When specifying light finish the natural characteristics of the wood will be visible and color will vary.

Ganging brackets are sold separately and will ship with the product. See Luca accessories page to order brackets. .

Power: Surface mount power provides (2) 15 amp receptables, (1) 2 amp USB-A port, 10 watt and (1) 2 amp USB-C port, 20 watt.

SCS Indoor Advantage™ Gold and LEVEL® 2 certified. See terms and conditions for additional finish and environmental information.

Seat Height	Arm Height	W	D	H	Fabric	Leather	Weight	Cubes/Qty
16½"	-	115¼"	28¾"	16½"	8.5 yds.	140.0'	181 lbs.	50.0'/1
419 mm	-	2921 mm	730 mm	419 mm	7.8 m	13.0 sqm	82.1 kg	1.40 cu.

COM	COL	1	2	3	4	5	6	7	8	9	10	11
4519	4689	5313	5445	5521	5672	5804	5861	5955	6087	6201	6333	7088

sku	frame finish	run-off top species	wood top finish
	6 polished aluminum standard, OR specify powder coat, upcharge \$200 3 matte black powder coat W satin white powder coat	C oak 9 walnut	see seating finishes

description	sku	w	d	h	price
 <p>ganging bracket Order one ganging bracket per point of connection of modular units. Ganging brackets are sold separately and will ship with product.</p>	111	14½	9½	3½	\$ 108

series

sku

8 | D |

1 | 1 | 1 |

mirador 8040A



Bench
Polished aluminum frame
Upholstered

Levelers and non-marring glides

SCS Indoor Advantage™ Gold and LEVEL® 2 certified. See terms and conditions for additional environmental information.

Seat Height	Arm Height	W	D	H	Fabric	Leather	Weight	Cubes/Qty
16½"	-	30"	28¾"	16½"	3.0 yds	40.0'	55 lbs	22.67/1
419 mm	-	762 mm	730 mm	419 mm	2.7 m	3.7 sqm	25.0 kg	.64 cu

COM	COL	1	2	3	4	5	6	7	8	9	10	11
1606	1666	1886	1933	1960	2013	2060	2080	2113	2160	2200	2246	2513

mirador 8041A

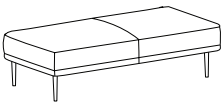

Two-seat bench
Polished aluminum frame
Upholstered

Levelers and non-marring glides

SCS Indoor Advantage™ Gold and LEVEL® 2 certified. See terms and conditions for additional environmental information.

Seat Height	Arm Height	W	D	H	Fabric	Leather	Weight	Cubes/Qty
16½"	-	60"	28¾"	16½"	5.5 yds	75.0'	122 lbs	68.33/1
419 mm	-	1524 mm	730 mm	419 mm	5.0 m	7.0 sqm	55.5 kg	1.93 cu

COM	COL	1	2	3	4	5	6	7	8	9	10	11
2493	2603	3007	3092	3141	3239	3325	3361	3422	3508	3581	3667	4156

mirador 8042A

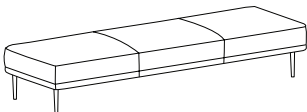

Three-seat bench
Polished aluminum frame
Upholstered

Levelers and non-marring glides

SCS Indoor Advantage™ Gold and LEVEL® 2 certified. See terms and conditions for additional environmental information.

Seat Height	Arm Height	W	D	H	Fabric	Leather	Weight	Cubes/Qty
16½"	-	90"	28¾"	16½"	7.5 yds	101.0'	181 lbs	101.65/1
419 mm	-	2286 mm	730 mm	419 mm	6.9 m	9.4 sqm	82.3 kg	2.87 cu

COM	COL	1	2	3	4	5	6	7	8	9	10	11
2670	2820	3370	3487	3554	3687	3804	3854	3937	4054	4154	4270	4937

pause 5838



**Two-seat bench
Solid maple frame
Upholstered**

Fabric railroaded
Standard with accent welt
Leather and leather alternatives will have a center seam

Available in all maple finishes. When specifying light finishes the natural characteristics of the wood will be visible and color will vary.

When using a combination of fabrics or leathers, specify the application by designating the appropriate letter, shown below, on the purchase order. Yardage shown must be used.

See terms and conditions for contrasting upholstery and welt upcharges.

- A) One fabric or leather for seat cushion
yardage: 1.8 yds. leather: 25.0 sq. ft.
- B) One fabric or leather for contrasting welt
yardage: .5 yds. leather: 15.0 sq. ft.

SCS Indoor Advantage™ Gold and LEVEL® 2 certified. See terms and conditions for additional environmental information.

Seat Height	Arm Height	W	D	H	Fabric	Leather	Weight	Cubes/Qty
17 $\frac{3}{8}$ "	-	60"	20"	17 $\frac{3}{8}$ "	1.8 yds	30.0'	60 lbs	29.34/1
441 mm	-	1524 mm	508 mm	441 mm	1.6 m	2.8 sqm	27.2 kg	.83 cu

COM	COL	1	2	3	4	5	6	7	8	9	10	11
2694	2730	2862	2890	2906	2938	2966	2978	2998	3026	3050	3078	3238

stay 5860, 5860G

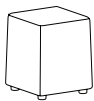

**Ottoman
Fully upholstered**

5860 **Concealed casters**
5860G **Glides**

Available with four small concealed casters

SCS Indoor Advantage™ Gold and LEVEL® 2 certified. See terms and conditions for additional environmental information.

Seat Height	Arm Height	W	D	H	Fabric	Leather	Weight	Cubes/Qty
19 $\frac{1}{4}$ "	-	16"	16"	19 $\frac{1}{4}$ "	2.25 yds	40.0'	24 lbs	7.0/1
489 mm	-	406 mm	406 mm	489 mm	2.1 m	3.7 sqm	10.9 kg	0.19 cu

COM	COL	1	2	3	4	5	6	7	8	9	10	11
688	733	898	933	953	993	1028	1043	1068	1103	1133	1168	1368

tour 5880

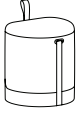

Ottoman with leather handle
Fully upholstered

Non-slip base surface

Seat and main body available in any approved Bernhardt Textiles, COM or COL. Back and lower body available only in leather and coated fabrics.

COM/COL price includes belting leather handle. Specify approved inline Bernhardt Textiles as COM/COL.

Seat and main body available in any approved COM, COL or Bernhardt Textiles. Specify approved inline Bernhardt Textiles as COM/COL.

When using a combination of fabrics or leather, specify the application by designating the appropriate letter, shown below, on the purchase order. Yardage shown must be used. Contrasting upcharge not applicable.

*A) One fabric, coated fabric or leather for seat and main upper body.
yardage: 1.0 yds. leather: 18.0 sq. ft.

Back and lower body available only in coated fabrics and leather. Specify approved inline Bernhardt Textiles as COM/COL.

**B) One coated fabric or leather for back and lower body.
yardage: 1.0 yds. leather: 18.0 sq. ft.

SCS Indoor Advantage™ Gold and LEVEL® 2 Certified. See terms and conditions for additional environmental information.

Seat Height	Arm Height	W	D	H	Fabric	Leather	Weight	Cubes/Qty
19¼"	-	17"	14¾"	19¼"	*	**	21 lbs	12.1/1
489 mm	-	432 mm	372 mm	489 mm	*	**	9.5 kg	.34 su.

COM
1407

sku

5	8	8	0
---	---	---	---

leather handle

BL	black belting
BR	brown belting

alta 580



**Mid back swivel
5-star polished aluminum base and arms
Adjustable height**

Cantilevered arms with upholstered arm pads
Synchro tilt mechanism with adjustable height gas pneumatic lift

Inside seat width: 19½", Inside seat depth: 19¾", Inside arm height: 7"

SCS Indoor Advantage™ Gold and LEVEL® 2 certified. See terms and conditions for additional environmental information.

Seat Height	Arm Height	W	D	H	Fabric	Leather	Weight	Cubes/Qty
17½-20½"	24-27"	25½"	25⅞"	33½-36½"	2 yd	30.0'	57 lbs	28.98'/1
445-521 mm	610-686 mm	648 mm	657mm	851-927 mm	1.8 m	2.79 sqm	25.9 kg	.82 cu

COM	COL	1	2	3	4	5	6	7	8	9	10	11
2172	2212	2359	2390	2408	2444	2475	2488	2510	2541	2568	2599	2777

alta 580F



**Mid back swivel
5-star polished aluminum base and arms
Fixed height**

Cantilevered arms with upholstered arm pads
Synchro tilt mechanism with fixed height

Inside seat width: 19½", Inside seat depth: 19¾", Inside arm height: 7"

SCS Indoor Advantage™ Gold and LEVEL® 2 certified. See terms and conditions for additional environmental information.

Seat Height	Arm Height	W	D	H	Fabric	Leather	Weight	Cubes/Qty
19¾"	24-27"	25½"	25⅞"	33½-36½"	2 yd	30.0'	57 lbs	28.98'/1
445-521 mm	610-686 mm	648 mm	657mm	851-927 mm	1.8 m	2.79 sqm	25.9 kg	.82 cu

COM	COL	1	2	3	4	5	6	7	8	9	10	11
2172	2212	2359	2390	2408	2444	2475	2488	2510	2541	2568	2599	2777

alta 580K



**Mid back swivel
5-star matte black powder coat base and arms
Adjustable height**

Cantilevered arms with upholstered arm pads
Synchro tilt mechanism with adjustable height gas pneumatic lift

Inside seat width: 19½", Inside seat depth: 19¾", Inside arm height: 7"

SCS Indoor Advantage™ Gold and LEVEL® 2 certified. See terms and conditions for additional environmental information.

Seat Height	Arm Height	W	D	H	Fabric	Leather	Weight	Cubes/Qty
17½-20½"	24-27"	25½"	25⅞"	33½-36½"	2 yd	30.0'	57 lbs	28.98'/1
445-521 mm	610-686 mm	648 mm	657mm	851-927 mm	1.8 m	2.79 sqm	25.9 kg	.82 cu

COM	COL	1	2	3	4	5	6	7	8	9	10	11
2322	2362	2509	2540	2558	2594	2625	2638	2660	2691	2718	2749	2927

alta 582



**Mid back swivel
5-star polished aluminum base and arms
Adjustable height**

Upholstered back pad
Cantilevered arms with upholstered arm pads
Synchro tilt mechanism with adjustable height gas pneumatic lift

Inside seat width: 19½", Inside seat depth: 19¼", Inside arm height: 7"

When using a combination of fabrics or leathers, specify the application by designating the appropriate letter, shown below, on the purchase order. Yardage shown must be used.

See terms and conditions for contrasting fabric and welt upcharges.

- A) One fabric or leather for seat, back, and arm pads
yardage: 2.0 yds. leather: 30.0 sq. ft.
- B) One fabric or leather for back pad and welt
yardage: 1.0 yds. leather: 13.5 sq. ft.

SCS Indoor Advantage™ Gold and LEVEL® 2 certified. See terms and conditions for additional environmental information.

Seat Height	Arm Height	W	D	H	Fabric	Leather	Weight	Cubes/Qty
17½"-20½"	24-27"	25½"	25⅝"	33½"-36½"	3.0 yd	43.5'	57 lbs	28.98'/1
445-521 mm	610-686 mm	648 mm	657mm	851-927 mm	2.8 m	4.0 sqm	25.9 kg	.82 cu

COM	COL	1	2	3	4	5	6	7	8	9	10	11
2580	2640	2860	2907	2934	2987	3034	3054	3087	3134	3174	3220	3487

alta 582F



**Mid back swivel
5-star polished aluminum base and arms
Fixed height**

Upholstered back pad
Cantilevered arms with upholstered arm pads
Synchro tilt mechanism with fixed height

Inside seat width: 19½", Inside seat depth: 19¼", Inside arm height: 7"

When using a combination of fabrics or leathers, specify the application by designating the appropriate letter, shown below, on the purchase order. Yardage shown must be used.

See terms and conditions for contrasting fabric and welt upcharges.

- A) One fabric or leather for seat, back, and arm pads
yardage: 2.0 yds. leather: 30.0 sq. ft.
- B) One fabric or leather for back pad and welt
yardage: 1.0 yds. leather: 13.5 sq. ft.

SCS Indoor Advantage™ Gold and LEVEL® 2 certified. See terms and conditions for additional environmental information.

Seat Height	Arm Height	W	D	H	Fabric	Leather	Weight	Cubes/Qty
19¼"	24-27"	25½"	25⅝"	33½"-36½"	3.0 yd	43.5'	57 lbs	28.98'/1
445-521 mm	610-686 mm	648 mm	657mm	851-927 mm	2.8 m	4.0 sqm	25.9 kg	.82 cu

COM	COL	1	2	3	4	5	6	7	8	9	10	11
2580	2640	2860	2907	2934	2987	3034	3054	3087	3134	3174	3220	3487

alta 582K



**Mid back swivel
5-star matte black powder coat base and arms
Adjustable height**

Upholstered back pad
Cantilevered arms with upholstered arm pads
Synchro tilt mechanism with adjustable height gas pneumatic lift

Inside seat width: 19½", Inside seat depth: 19¾", Inside arm height: 7"

When using a combination of fabrics or leathers, specify the application by designating the appropriate letter, shown below, on the purchase order. Yardage shown must be used.

See terms and conditions for contrasting fabric and welt upcharges.

- A) One fabric or leather for seat, back, and arm pads
yardage: 2.0 yds. leather: 30.0 sq. ft.
- B) One fabric or leather for back pad and welt
yardage: 1.0 yds. leather: 13.5 sq. ft.

SCS Indoor Advantage™ Gold and LEVEL® 2 certified. See terms and conditions for additional environmental information.

Seat Height	Arm Height	W	D	H	Fabric	Leather	Weight	Cubes/Qty
17½"-20½"	24-27"	25½"	25¾"	33½"-36½"	3.0 yd	43.5'	57 lbs	28.98'/1
445-521 mm	610-686 mm	648 mm	657mm	851-927 mm	2.8 m	4.0 sqm	25.9 kg	.82 cu

COM	COL	1	2	3	4	5	6	7	8	9	10	11
2730	2790	3010	3057	3084	3137	3184	3204	3237	3284	3324	3370	3637

alta 584



**Mid back swivel
5-star polished aluminum base
Adjustable height**

Leather with perforated leather back pad
Cantilevered arms with leather arm pads
Synchro tilt mechanism with adjustable height gas pneumatic lift

Inside seat width: 19½", Inside seat depth: 19¾", Inside arm height: 7"

Available only in Bernhardt Textiles Rogue or Essential leather. Same leather used for arms and back pad. Consult Bernhardttextiles.com for colorways.

Perforated leather in the Pique pattern for the back pad may be specified in Rogue or Essential by adding the suffix P to the end of the item number. The Pique pattern is subject to the minimum purchase requirements per colorway in addition to an upcharge of \$1.00 per sq. ft.

Specify the fabric or leather application by designating the appropriate letter on the purchase order.

- Leather Requirements:
- A) Rogue or Essential leather for seat, back, arm pads and back pad welt
leather: 30.0 sq. ft.
 - B) Pique pattern in Rogue or Essential leather for back pad
perforated leather: 13.5 sq. ft.

SCS Indoor Advantage™ Gold and LEVEL® 2 certified. See terms and conditions for additional environmental information.

Seat Height	Arm Height	W	D	H	Fabric	Leather	Weight	Cubes/Qty
17½"-20½"	24-27"	25½"	25¾"	33½"-36½"	-	-	57 lbs	28.98'/1
445-521 mm	610-686 mm	648 mm	657mm	851-927 mm	-	-	25.9 kg	.82 cu

COL
2844

alta 584F



**Mid back swivel
5-star polished aluminum base and arms
Fixed height**

Leather with perforated leather back pad
Cantilevered arms with leather arm pads
Synchro tilt mechanism with fixed height

Inside seat width: 19½", Inside seat depth: 19¾", Inside arm height: 7"

Available only in Bernhardt Textiles Rogue or Essential leather. Same leather used for arms and back pad. Consult Bernhardttextiles.com for colorways.

Perforated leather in the Pique pattern for the back pad may be specified in Rogue or Essential by adding the suffix P to the end of the item number. The Pique pattern is subject to the minimum purchase requirements per colorway in addition to an upcharge of \$1.00 per sq. ft.

Specify the fabric or leather application by designating the appropriate letter on the purchase order.

Leather Requirements:

- A) Rogue or Essential leather for seat, back, arm pads and back pad welt
leather: 30.0 sq. ft.
- B) Pique pattern in Rogue or Essential leather for back pad
perforated leather: 13.5 sq. ft.

SCS Indoor Advantage™ Gold and LEVEL® 2 certified. See terms and conditions for additional environmental information.

Seat Height	Arm Height	W	D	H	Fabric	Leather	Weight	Cubes/Qty
19¾"	24-27"	25½"	25⅞"	33½-36½"	-	-	57 lbs	28.98/1
445-521 mm	610-686 mm	648 mm	657mm	851-927 mm	-	-	25.9 kg	.82 cu

COL
2844

alta 584K



**Mid back swivel
5-star matte black powder coat base and arms
Adjustable height**

Leather with perforated leather back pad
Cantilevered arms with leather arm pads
Synchro tilt mechanism with adjustable height gas pneumatic lift

Inside seat width: 19½", Inside seat depth: 19¾", Inside arm height: 7"

Available only in Bernhardt Textiles Rogue or Essential leather. Same leather used for arms and back pad. Consult Bernhardttextiles.com for colorways.

Perforated leather in the Pique pattern for the back pad may be specified in Rogue or Essential by adding the suffix P to the end of the item number. The Pique pattern is subject to the minimum purchase requirements per colorway in addition to an upcharge of \$1.00 per sq. ft.

Specify the fabric or leather application by designating the appropriate letter on the purchase order.

Leather Requirements:

- A) Rogue or Essential leather for seat, back, arm pads and back pad welt
leather: 30.0 sq. ft.
- B) Pique pattern in Rogue or Essential leather for back pad
perforated leather: 13.5 sq. ft.

SCS Indoor Advantage™ Gold and LEVEL® 2 certified. See terms and conditions for additional environmental information.

Seat Height	Arm Height	W	D	H	Fabric	Leather	Weight	Cubes/Qty
17½-20½"	24-27"	25½"	25⅞"	33½-36½"	-	-	57 lbs	28.98/1
445-521 mm	610-686 mm	648 mm	657mm	851-927 mm	-	-	25.9 kg	.82 cu

COL
2994

alta 581



**High back swivel
5-star polished aluminum base and arms
Adjustable height**

Cantilevered arms with upholstered arm pads
Synchro tilt mechanism with adjustable height gas pneumatic lift

Inside seat width: 19½", Inside seat depth: 19¼", Inside arm height: 7"

SCS Indoor Advantage™ Gold and LEVEL® 2 certified. See terms and conditions for additional environmental information.

Seat Height	Arm Height	W	D	H	Fabric	Leather	Weight	Cubes/Qty
17½"-20½"	24-27"	25½"	25⅞"	36%-39⅜"	2.5 yd	32.0'	57 lbs	28.98'/1
445-521 mm	610-686 mm	648 mm	657mm	924-1000 mm	2.3 m	2.97 sqm	25.9 kg	.82 cu

COM	COL	1	2	3	4	5	6	7	8	9	10	11
2311	2361	2545	2584	2606	2650	2689	2706	2734	2773	2806	2845	3067

alta 581F



**High back swivel
5-star polished aluminum base and arms
Fixed height**

Cantilevered arms with upholstered arm pads
Synchro tilt mechanism with fixed height

Inside seat width: 19½", Inside seat depth: 19¼", Inside arm height: 7"

SCS Indoor Advantage™ Gold and LEVEL® 2 certified. See terms and conditions for additional environmental information.

Seat Height	Arm Height	W	D	H	Fabric	Leather	Weight	Cubes/Qty
19¼"	24-27"	25½"	25⅞"	36%-39⅜"	2.5 yd	32.0'	57 lbs	28.98'/1
445-521 mm	610-686 mm	648 mm	657mm	924-1000 mm	2.3 m	2.97 sqm	25.9 kg	.82 cu

COM	COL	1	2	3	4	5	6	7	8	9	10	11
2311	2361	2545	2584	2606	2650	2689	2706	2734	2773	2806	2845	3067

alta 581K



**High back swivel
5-star matte black powder coat base and arms
Adjustable height**

Cantilevered arms with upholstered arm pads
Synchro tilt mechanism with adjustable height gas pneumatic lift

Inside seat width: 19½", Inside seat depth: 19¼", Inside arm height: 7"

SCS Indoor Advantage™ Gold and LEVEL® 2 certified. See terms and conditions for additional environmental information.

Seat Height	Arm Height	W	D	H	Fabric	Leather	Weight	Cubes/Qty
17½"-20½"	24-27"	25½"	25⅞"	36%-39⅜"	2.5 yd	32.0'	57 lbs	28.98'/1
445-521 mm	610-686 mm	648 mm	657mm	924-1000 mm	2.3 m	2.97 sqm	25.9 kg	.82 cu

COM	COL	1	2	3	4	5	6	7	8	9	10	11
2461	2511	2695	2734	2756	2800	2839	2856	2884	2923	2956	2995	3217

alta 583



**High back swivel
5-star polished aluminum base and arms
Adjustable height**

Upholstered back pad
Cantilevered arms with upholstered arm pads
Synchro tilt mechanism with adjustable height gas pneumatic lift

Inside seat width: 19½", Inside seat depth: 19¾", Inside arm height: 7"

When using a combination of fabrics or leathers, specify the application by designating the appropriate letter, shown below, on the purchase order. Yardage shown must be used.

See terms and conditions for contrasting fabric and welt upcharges.

- A) One fabric or leather for seat, back, and arm pads
yardage: 2.5 yds. leather: 32.0 sq. ft.
- B) One fabric or leather for back pad and welt
yardage: 1.0 yds. leather: 13.5 sq. ft.

SCS Indoor Advantage™ Gold and LEVEL® 2 certified. See terms and conditions for additional environmental information.

Seat Height	Arm Height	W	D	H	Fabric	Leather	Weight	Cubes/Qty
17½"-20½"	24-27"	25½"	25¾"	36%-39¾"	3.5 yd	45.5'	57 lbs	28.98'/1
445-521 mm	610-686 mm	648 mm	657mm	924-1000 mm	3.2 m	4.2 sqm	25.9 kg	.82 cu

COM	COL	1	2	3	4	5	6	7	8	9	10	11
2764	2834	3091	3146	3177	3239	3293	3317	3356	3410	3457	3511	3822

alta 583F



**High back swivel
5-star polished aluminum base and arms
Fixed height**

Upholstered back pad
Cantilevered arms with upholstered arm pads
Synchro tilt mechanism with fixed height

Inside seat width: 19½", Inside seat depth: 19¾", Inside arm height: 7"

When using a combination of fabrics or leathers, specify the application by designating the appropriate letter, shown below, on the purchase order. Yardage shown must be used.

See terms and conditions for contrasting fabric and welt upcharges.

- A) One fabric or leather for seat, back, and arm pads
yardage: 2.5 yds. leather: 32.0 sq. ft.
- B) One fabric or leather for back pad and welt
yardage: 1.0 yds. leather: 13.5 sq. ft.

SCS Indoor Advantage™ Gold and LEVEL® 2 certified. See terms and conditions for additional environmental information.

Seat Height	Arm Height	W	D	H	Fabric	Leather	Weight	Cubes/Qty
19¾"	24-27"	25½"	25¾"	36%-39¾"	3.5 yd	45.5'	57 lbs	28.98'/1
445-521 mm	610-686 mm	648 mm	657mm	924-1000 mm	3.2 m	4.2 sqm	25.9 kg	.82 cu

COM	COL	1	2	3	4	5	6	7	8	9	10	11
2764	2834	3091	3146	3177	3239	3293	3317	3356	3410	3457	3511	3822

alta 583K



**High back swivel
5-star matte black powder coat base and arms
Adjustable height**

Upholstered back pad
Cantilevered arms with upholstered arm pads
Synchro tilt mechanism with gas pneumatic lift

Inside seat width: 19½", Inside seat depth: 19¼", Inside arm height: 7"

When using a combination of fabrics or leathers, specify the application by designating the appropriate letter, shown below, on the purchase order. Yardage shown must be used.

See terms and conditions for contrasting fabric and welt upcharges.

- A) One fabric or leather for seat, back, and arm pads
yardage: 2.5 yds. leather: 32.0 sq. ft.
- B) One fabric or leather for back pad and welt
yardage: 1.0 yds. leather: 13.5 sq. ft.

SCS Indoor Advantage™ Gold and LEVEL® 2 certified. See terms and conditions for additional environmental information.

Seat Height	Arm Height	W	D	H	Fabric	Leather	Weight	Cubes/Qty
17½"-20½"	24-27"	25½"	25¾"	36¾"-39¾"	3.5 yd	45.5'	57 lbs	28.98/1
445-521 mm	610-686 mm	648 mm	657mm	924-1000 mm	3.2 m	4.2 sqm	25.9 kg	.82 cu

COM	COL	1	2	3	4	5	6	7	8	9	10	11
2914	2984	3241	3296	3327	3389	3443	3467	3506	3560	3607	3661	3972

alta 585



**High back swivel
5-star polished aluminum base
Adjustable height**

Leather with perforated leather back pad
Cantilevered arms with leather arm pads
Swivel/tilt mechanism with gas pneumatic lift

Inside seat width: 19½", Inside seat depth: 19¼", Inside arm height: 7"

Available only in Bernhardt Textiles Rogue or Essential leather. Same leather used for arms and back pad. Consult Bernhardttextiles.com for colorways.

Perforated leather in the Pique pattern for the back pad may be specified in Rogue or Essential by adding the suffix P to the end of the item number. The Pique pattern is subject to the minimum purchase requirements per colorway in addition to an upcharge of \$1.00 per sq. ft.

Specify the fabric or leather application by designating the appropriate letter on the purchase order.

- Leather Requirements:
- A) Rogue or Essential leather for seat, back, arm pads and back pad welt
leather: 32.0 sq. ft.
 - B) Pique pattern in Rogue or Essential leather for back pad
perforated leather: 13.5 sq. ft.

SCS Indoor Advantage™ Gold and LEVEL® 2 certified. See terms and conditions for additional environmental information.

Seat Height	Arm Height	W	D	H	Fabric	Leather	Weight	Cubes/Qty
17½"-20½"	24-27"	25½"	25¾"	36¾"-39¾"	-	-	57 lbs	28.98/1
445-521 mm	610-686 mm	648 mm	657mm	924-1000 mm	-	-	25.9 kg	.82 cu

COL
3046

alta 585F



**High back swivel
5-star polished aluminum base and arms
Fixed height**

Leather with perforated leather back pad
Cantilevered arms with leather arm pads
Synchro tilt mechanism with fixed height

Inside seat width: 19½", Inside seat depth: 19¼", Inside arm height: 7"

Available only in Bernhardt Textiles Rogue or Essential leather. Same leather used for arms and back pad. Consult Bernhardttextiles.com for colorways.

Perforated leather in the Pique pattern for the back pad may be specified in Rogue or Essential by adding the suffix P to the end of the item number. The Pique pattern is subject to the minimum purchase requirements per colorway in addition to an upcharge of \$1.00 per sq. ft.

Specify the fabric or leather application by designating the appropriate letter on the purchase order.

Leather Requirements:

- A) Rogue or Essential leather for seat, back, arm pads and back pad welt
leather: 32.0 sq. ft.
- B) Pique pattern in Rogue or Essential leather for back pad
perforated leather: 13.5 sq. ft.

SCS Indoor Advantage™ Gold and LEVEL® 2 certified. See terms and conditions for additional environmental information.

Seat Height	Arm Height	W	D	H	Fabric	Leather	Weight	Cubes/Qty
19¼"	24-27"	25½"	25⅝"	36%-39⅝"	-	-	57 lbs	28.98/1
445-521 mm	610-686 mm	648 mm	657mm	924-1000 mm	-	-	25.9 kg	.82 cu

COL
3046

alta 585K



**High back swivel
5-star matte black powder coat base and arms
Adjustable height**

Leather with perforated leather back pad
Cantilevered arms with leather arm pads
Synchro tilt mechanism with adjustable height gas pneumatic lift

Inside seat width: 19½", Inside seat depth: 19¼", Inside arm height: 7"

Available only in Bernhardt Textiles Rogue or Essential leather. Same leather used for arms and back pad. Consult Bernhardttextiles.com for colorways.

Perforated leather in the Pique pattern for the back pad may be specified in Rogue or Essential by adding the suffix P to the end of the item number. The Pique pattern is subject to the minimum purchase requirements per colorway in addition to an upcharge of \$1.00 per sq. ft.

Specify the fabric or leather application by designating the appropriate letter on the purchase order.

Leather Requirements:

- A) Rogue or Essential leather for seat, back, arm pads and back pad welt
leather: 32.0 sq. ft.
- B) Pique pattern in Rogue or Essential leather for back pad
perforated leather: 13.5 sq. ft.

SCS Indoor Advantage™ Gold and LEVEL® 2 certified. See terms and conditions for additional environmental information.

Seat Height	Arm Height	W	D	H	Fabric	Leather	Weight	Cubes/Qty
17½"-20½"	24-27"	25½"	25⅝"	36%-39⅝"	-	-	57 lbs	28.98/1
445-521 mm	610-686 mm	648 mm	657mm	924-1000 mm	-	-	25.9 kg	.82 cu

COL
3196

aubry 605



**Mid back swivel
5-star polished aluminum or powder coat base and arms
Adjustable height**

Synchro tilt mechanism with adjustable height gas pneumatic lift

Inside seat width: 19", Inside seat depth: 18 1/4", Inside arm height: 6 1/4"

SCS Indoor Advantage™ Gold and LEVEL® 2 certified. See terms and conditions for additional environmental information.

Seat Height	Arm Height	W	D	H	Fabric	Leather	Weight	Cubes/Qty
18 1/4"-21 1/4"	24 3/8"-27 3/8"	25"	26 3/4"	35 1/2"-38 1/2"	2.75 yds.	45.0'	59 lbs.	29.00'/1
464-565 mm	619-695 mm	635 mm	679 mm	902-978 mm	2.6 m	4.2 sqm	26.8 kg	.82 cu.

COM	COL	1	2	3	4	5	6	7	8	9	10	11
1924	1979	2181	2224	2248	2297	2340	2358	2389	2432	2468	2511	2756

sku

6	0	5										

base finish

PA polished aluminum standard, OR

specify powder coat, upcharge \$150

- | | |
|-----------------------|-----------------------|
| WH satin white | IG iron grey |
| GR graphite | RD black red |
| BZ bronze | BK matte black |

--	--

chantal 1025



**Mid back swivel
5-star polished aluminum or matte black powder coat base
Adjustable height**

Swivel/tilt mechanism with adjustable height gas pneumatic lift

Inside seat width: 17¼", Inside seat depth: 18", Inside arm height: 7½"

When using a combination of fabrics or leathers, specify the application by designating the appropriate letter, shown below, on the purchase order. Yardage shown must be used.

See terms and conditions for contrasting fabric and welt upcharges.

- A) One fabric or leather for seat
yardage: 1.0 yds. leather: 15.0 sq. ft.
- B) One fabric or leather for inside back and arms, outside back and sides
yardage: 2.5 yds. leather: 40.5 sq. ft.

SCS Indoor Advantage™ Gold and LEVEL® 2 certified. See terms and conditions for additional environmental information.

Seat Height	Arm Height	W	D	H	Fabric	Leather	Weight	Cubes/Qty
18¼-22¼"	25¼-29¼"	25½"	26"	33-37"	3.0 yd	40.0'	48 lbs	27.56'/1
464-565 mm	641-743 mm	648 mm	660 mm	838-940 mm	2.7 m	3.7 sqm	21.8 kg	.78 cu

COM	COL	1	2	3	4	5	6	7	8	9	10	11
1842	1902	2122	2169	2196	2249	2296	2316	2349	2396	2436	2482	2749

sku

1 0 2 5

base finish

polished aluminum standard, OR
 specify powder coat, upcharge \$100
K matte black

chloe 1022



**Mid back armless swivel
5-star polished aluminum base
Adjustable height**

Swivel/tilt mechanism with adjustable height gas pneumatic lift

Inside seat width: 19½", Inside seat depth: 17⅞"

When using a combination of fabrics or leathers, specify the application by designating the appropriate letter, shown below, on the purchase order. Yardage shown must be used.

See terms and conditions for contrasting fabric and welt upcharges.

- A) One fabric or leather for seat
yardage: 1.0 yds. leather: 15.0 sq. ft.
- B) One fabric or leather for inside back and outside back
yardage: 2.0 yds. leather: 35.0 sq. ft.

SCS Indoor Advantage™ Gold and LEVEL® 2 certified. See terms and conditions for additional environmental information.

Seat Height	Arm Height	W	D	H	Fabric	Leather	Weight	Cubes/Qty
18¼"-22¼"	-	24¼"	26"	31⅝" - 35⅝"	2.25 yd	35.0'	47 lbs	27.56'/1
464-565 mm	-	616 mm	660 mm	803-905 mm	2.1 m	3.3 sqm	21.3 kg	.78 cu

COM	COL	1	2	3	4	5	6	7	8	9	10	11
1503	1548	1713	1748	1768	1808	1843	1858	1883	1918	1948	1983	2183

sku

1	0	2	2	

base finish

polished aluminum standard, OR
 specify powder coat, upcharge \$100
K matte black

duet 570



**Mid back swivel
5-star polished aluminum base
Tubular chrome arms
Adjustable height**

Swivel/tilt mechanism with adjustable height gas pneumatic lift

Inside seat width: 19⅝", Inside seat depth: 17⅞", Inside arm height: 7"

SCS Indoor Advantage™ Gold and LEVEL® 2 certified. See terms and conditions for additional environmental information.

Seat Height	Arm Height	W	D	H	Fabric	Leather	Weight	Cubes/Qty
17⅞"-19⅞"	24-26⅞"	24¼"	24⅞"	32¾"-35½"	2.5 yd	35.0'	50 lbs	22.25'/1
435-505 mm	610-679 mm	616 mm	632 mm	832-902 mm	2.3 m	3.3 sqm	22.6 kg	.63 cu

COM	COL	1	2	3	4	5	6	7	8	9	10	11
1659	1709	1893	1932	1954	1998	2037	2054	2082	2121	2154	2193	2415

duet 571



Mid back swivel
5-star matte black powder coat base
Tubular chrome arms
Adjustable height

Swivel/tilt mechanism with adjustable height gas pneumatic lift

Inside seat width: 19½", Inside seat depth: 17¾", Inside arm height: 7"

SCS Indoor Advantage™ Gold and LEVEL® 2 certified. See terms and conditions for additional environmental information.

Seat Height	Arm Height	W	D	H	Fabric	Leather	Weight	Cubes/Qty
17½"-19½"	24-26¾"	24¼"	24¾"	32¾"-35½"	2.5 yd	35.0'	50 lbs	22.25/1

435-505 mm	610-679 mm	616 mm	632 mm	832-902 mm	2.3 m	3.3 sqm	22.6 kg	.63 cu
------------	------------	--------	--------	------------	-------	---------	---------	--------

COM	COL	1	2	3	4	5	6	7	8	9	10	11
1759	1809	1993	2032	2054	2098	2137	2154	2182	2221	2254	2293	2515

duet 572



Mid back swivel
5-star polished aluminum base
Tubular chrome arms
Adjustable height

Upholstered with horizontal quilting

Swivel/tilt mechanism with adjustable height gas pneumatic lift

Inside seat width: 19½", Inside seat depth: 17¾", Inside arm height: 7"

Horizontal stripes and two-way patterns are not recommended for application on this product.

SCS Indoor Advantage™ Gold and LEVEL® 2 certified. See terms and conditions for additional environmental information.

Seat Height	Arm Height	W	D	H	Fabric	Leather	Weight	Cubes/Qty
17½"-19½"	24-26¾"	24¼"	24¾"	32¾"-35½"	2.5 yd	35.0'	50 lbs	22.25/1

435-505 mm	610-679 mm	616 mm	632 mm	832-902 mm	2.3 m	3.3 sqm	22.6 kg	.63 cu
------------	------------	--------	--------	------------	-------	---------	---------	--------

COM	COL	1	2	3	4	5	6	7	8	9	10	11
2080	2130	2314	2353	2375	2419	2458	2475	2503	2542	2575	2614	2836

duet 573



Mid back swivel
5-star matte black powder coat base
Tubular chrome arms
Adjustable height

Upholstered with horizontal quilting
 Swivel/tilt mechanism with adjustable height gas pneumatic lift

Inside seat width: 19½", Inside seat depth: 17¾", Inside arm height: 7"

Horizontal stripes and two-way patterns are not recommended for application on this product.

SCS Indoor Advantage™ Gold and LEVEL® 2 certified. See terms and conditions for additional environmental information.

Seat Height	Arm Height	W	D	H	Fabric	Leather	Weight	Cubes/Qty
17½"-19½"	24-26¼"	24½"	24¾"	32¾"-35½"	2.5 yd	35.0'	50 lbs	22.25/1
435-505 mm	610-679 mm	616 mm	632 mm	832-902 mm	2.3 m	3.3 sqm	22.6 kg	.63 cu

COM	COL	1	2	3	4	5	6	7	8	9	10	11
2180	2230	2414	2453	2475	2519	2558	2575	2603	2642	2675	2714	2936

duet 574



Mid back swivel
5-star polished aluminum base
Polished stainless steel flat arms
Adjustable height

Swivel/tilt mechanism with adjustable height gas pneumatic lift

Inside seat width: 19½", Inside seat depth: 17¾", Inside arm height: 7"

SCS Indoor Advantage™ Gold and LEVEL® 2 certified. See terms and conditions for additional environmental information.

Seat Height	Arm Height	W	D	H	Fabric	Leather	Weight	Cubes/Qty
17½"-19½"	24-26¼"	24½"	24¾"	32¾"-35½"	2.5 yd	35.0'	50 lbs	22.25/1
435-505 mm	610-679 mm	616 mm	632 mm	832-902 mm	2.3 m	3.3 sqm	22.6 kg	.63 cu

COM	COL	1	2	3	4	5	6	7	8	9	10	11
1940	1990	2174	2213	2235	2279	2318	2335	2363	2402	2435	2474	2696

duet 574K



Mid back swivel
5-star matte black powder coat base
Matte black powder coat flat arms
Adjustable height

Swivel/tilt mechanism with adjustable height gas pneumatic lift

Inside seat width: 19 $\frac{1}{8}$ ", Inside seat depth: 17 $\frac{7}{8}$ ", Inside arm height: 7"

SCS Indoor Advantage™ Gold and LEVEL® 2 certified. See terms and conditions for additional environmental information.

Seat Height	Arm Height	W	D	H	Fabric	Leather	Weight	Cubes/Qty
17 $\frac{1}{8}$ -19 $\frac{1}{8}$ "	24-26 $\frac{1}{4}$ "	24 $\frac{1}{4}$ "	24 $\frac{7}{8}$ "	32 $\frac{3}{4}$ "-35 $\frac{1}{2}$ "	2.5 yd	35.0'	50 lbs	22.25/1
435-505 mm	610-679 mm	616 mm	632 mm	832-902 mm	2.3 m	3.3 sqm	22.6 kg	.63 cu

COM	COL	1	2	3	4	5	6	7	8	9	10	11
2090	2140	2324	2363	2385	2429	2468	2485	2513	2552	2585	2624	2846

duet 575



Mid back swivel
5-star matte black powder coat base
Polished stainless steel flat arms
Adjustable height

Swivel/tilt mechanism with adjustable height gas pneumatic lift

Inside seat width: 19 $\frac{1}{8}$ ", Inside seat depth: 17 $\frac{7}{8}$ ", Inside arm height: 7"

SCS Indoor Advantage™ Gold and LEVEL® 2 certified. See terms and conditions for additional environmental information.

Seat Height	Arm Height	W	D	H	Fabric	Leather	Weight	Cubes/Qty
17 $\frac{1}{8}$ -19 $\frac{1}{8}$ "	24-26 $\frac{1}{4}$ "	24 $\frac{1}{4}$ "	24 $\frac{7}{8}$ "	32 $\frac{3}{4}$ "-35 $\frac{1}{2}$ "	2.5 yd	35.0'	50 lbs	22.25/1
435-505 mm	610-679 mm	616 mm	632 mm	832-902 mm	2.3 m	3.3 sqm	22.6 kg	.63 cu

COM	COL	1	2	3	4	5	6	7	8	9	10	11
2040	2090	2274	2313	2335	2379	2418	2435	2463	2502	2535	2574	2796

duet 576



Mid back swivel
5-star polished cast aluminum base
Polished stainless steel flat arms
Adjustable height

Upholstered with horizontal quilting

Swivel/tilt mechanism with adjustable height gas pneumatic lift

Inside seat width: 19 $\frac{1}{8}$ ", Inside seat depth: 17 $\frac{7}{8}$ ", Inside arm height: 7"

SCS Indoor Advantage™ Gold and LEVEL® 2 certified. See terms and conditions for additional environmental information.

Seat Height	Arm Height	W	D	H	Fabric	Leather	Weight	Cubes/Qty
17 $\frac{1}{8}$ -19 $\frac{1}{8}$ "	24-26 $\frac{1}{4}$ "	24 $\frac{1}{4}$ "	24 $\frac{7}{8}$ "	32 $\frac{3}{4}$ "-35 $\frac{1}{2}$ "	2.5 yd	35.0'	50 lbs	22.25/1
435-505 mm	610-679 mm	616 mm	632 mm	832-902 mm	2.3 m	3.3 sqm	22.6 kg	.63 cu

COM	COL	1	2	3	4	5	6	7	8	9	10	11
2387	2437	2621	2660	2682	2726	2765	2782	2810	2849	2882	2921	3143

duet 576K



Mid back swivel
5-star matte black powder coat base
Matte black power coat flat arms
Adjustable height

Upholstered with horizontal quilting
 Swivel/tilt mechanism with adjustable height gas pneumatic lift

Inside seat width: 19½", Inside seat depth: 17¾", Inside arm height: 7"

SCS Indoor Advantage™ Gold and LEVEL® 2 certified. See terms and conditions for additional environmental information.

Seat Height	Arm Height	W	D	H	Fabric	Leather	Weight	Cubes/Qty
17½"-19½"	24-26¾"	24½"	24¾"	32¾"-35½"	2.5 yd	35.0'	50 lbs	22.25/1
435-505 mm	610-679 mm	616 mm	632 mm	832-902 mm	2.3 m	3.3 sqm	22.6 kg	.63 cu

COM	COL	1	2	3	4	5	6	7	8	9	10	11
2537	2587	2771	2810	2832	2876	2915	2932	2960	2999	3032	3071	3293

duet 577



Mid back swivel
5-star matte black powder coat base
Polished stainless steel flat arms
Adjustable height

Upholstered with horizontal quilting
 Swivel/tilt mechanism with adjustable height gas pneumatic lift

Inside seat width: 19½", Inside seat depth: 17¾", Inside arm height: 7"

SCS Indoor Advantage™ Gold and LEVEL® 2 certified. See terms and conditions for additional environmental information.

Seat Height	Arm Height	W	D	H	Fabric	Leather	Weight	Cubes/Qty
17½"-19½"	24-26¾"	24½"	24¾"	32¾"-35½"	2.5 yd	35.0'	50 lbs	22.25/1
435-505 mm	610-679 mm	616 mm	632 mm	832-902 mm	2.3 m	3.3 sqm	22.6 kg	.63 cu

COM	COL	1	2	3	4	5	6	7	8	9	10	11
2487	2537	2721	2760	2782	2826	2865	2882	2910	2949	2982	3021	3243

kylo 600



Mid back swivel
5-star polished aluminum base
Adjustable height

Swivel/tilt mechanism with adjustable height gas pneumatic lift

Inside seat width: 19¼", Inside seat depth: 17¾", Inside arm height: 6¾"

SCS Indoor Advantage™ Gold and LEVEL® 2 certified. See terms and conditions for additional environmental information.

Seat Height	Arm Height	W	D	H	Fabric	Leather	Weight	Cubes/Qty
17½"-20½"	24¼"-27¼"	25½"	24¾"	34-37"	2.5 yds	40.5 m	40 lbs	27.55/1
445-521 mm	616-692 mm	648 mm	632 mm	864-940 mm	2.3 m	3.8 sqm	18.1 kg	.78 cu

COM	COL	1	2	3	4	5	6	7	8	9	10	11
1914	1964	2148	2187	2209	2253	2292	2309	2337	2376	2409	2448	2670

kylo 600K



**Mid back swivel
5-star matte black powder coat base
Adjustable height**

Swivel/tilt mechanism with adjustable height gas pneumatic lift

Inside seat width: 19¼", Inside seat depth: 17⅞", Inside arm height: 6¾"

SCS Indoor Advantage™ Gold and LEVEL® 2 certified. See terms and conditions for additional environmental information.

Seat Height	Arm Height	W	D	H	Fabric	Leather	Weight	Cubes/Qty
17½"-20½"	24¼"-27¼"	25½"	24⅞"	34"-37"	2.5 yds.	40.5'	40 lbs.	27.55'/1
445-521 mm	616-692 mm	648 mm	632 mm	864-940 mm	2.3 m	3.8 sqm	18.1 kg	.78 cu.

COM	COL	1	2	3	4	5	6	7	8	9	10	11
2014	2064	2248	2287	2309	2353	2392	2409	2437	2476	2509	2548	2770

kylo 602



**High back swivel
5-star polished aluminum base
Adjustable height**

Swivel/tilt mechanism with adjustable height gas pneumatic lift

Inside seat width: 19¼", Inside seat depth: 17⅞", Inside arm height: 6¾"

SCS Indoor Advantage™ Gold and LEVEL® 2 certified. See terms and conditions for additional environmental information.

Seat Height	Arm Height	W	D	H	Fabric	Leather	Weight	Cubes/Qty
17½"-20½"	24¼"-27¼"	25½"	24⅞"	37¼"-40¾"	2.6 yds.	42.0'	41 lbs.	27.55'/1
445-521 mm	616-692 mm	648 mm	632 mm	959-1035 mm	2.4 m	4.0 sqm	19.0 kg	.78 cu.

COM	COL	1	2	3	4	5	6	7	8	9	10	11
2088	2140	2331	2372	2395	2441	2481	2499	2528	2568	2603	2643	2874

kylo 602K



**High back swivel
5-star matte black powder coat base
Adjustable height**

Swivel/tilt mechanism with adjustable height gas pneumatic lift

Inside seat width: 19¼", Inside seat depth: 17⅞", Inside arm height: 6¾"

SCS Indoor Advantage™ Gold and LEVEL® 2 certified. See terms and conditions for additional environmental information.

Seat Height	Arm Height	W	D	H	Fabric	Leather	Weight	Cubes/Qty
17½"-20½"	24¼"-27¼"	25½"	24⅞"	37¼"-40¾"	2.6 yds.	42.0'	41 lbs.	27.55'/1
445-521 mm	616-692 mm	648 mm	632 mm	959-1035 mm	2.4 m	4.0 sqm	19.0 kg	.78 cu.

COM	COL	1	2	3	4	5	6	7	8	9	10	11
2188	2240	2431	2472	2495	2541	2581	2599	2628	2668	2703	2743	2974

I.a.m. 586

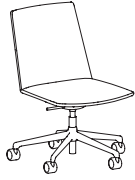

**Mid back armless swivel
5-star polished aluminum base
Adjustable height**

Swivel/tilt mechanism with adjustable height gas pneumatic lift

Outback standard with saddle stitch detail around the perimeter for fabric upholstered shells. Leather and leather alternative upholstered shells have saddle stitching accentuating the "V" detail on outback.

Inside seat width 20¾", Inside seat depth 17½"

SCS Indoor Advantage™ Gold and LEVEL® 2 certified. See terms and conditions for additional environmental information.

Seat Height	Arm Height	W	D	H	Fabric	Leather	Weight	Cubes/Qty
17¼-21¼"	-	24¾"	24¼"	33¾-37¾"	1.75 yd	24.0'	50 lbs	28.98'/1
438-540 mm	-	629 mm	616 mm	857-959 mm	1.6 m	2.2 sqm	22.7 kg	.82 cu

COM	COL	1	2	3	4	5	6	7	8	9	10	11
1681	1716	1845	1872	1888	1919	1946	1958	1977	2004	2028	2055	2210

I.a.m. 587

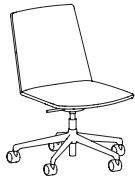

**Mid back armless swivel
5-star matte black powder coat base
Adjustable height**

Swivel/tilt mechanism with adjustable height gas pneumatic lift

Outback standard with saddle stitch detail around the perimeter for fabric upholstered shells. Leather and leather alternative upholstered shells have saddle stitching accentuating the "V" detail on outback.

Inside seat width 20¾", Inside seat depth 17½"

SCS Indoor Advantage™ Gold and LEVEL® 2 certified. See terms and conditions for additional environmental information.

Seat Height	Arm Height	W	D	H	Fabric	Leather	Weight	Cubes/Qty
17½-21¼"	-	24¾"	24¼"	33¾-37¾"	1.75 yd	24.0'	50 lbs	28.98'/1
438-540 mm	-	629 mm	616 mm	857-959 mm	1.6 m	2.2 sqm	22.7 kg	.82 cu

COM	COL	1	2	3	4	5	6	7	8	9	10	11
1781	1816	1945	1972	1988	2019	2046	2058	2077	2104	2128	2155	2310

I.a.m. 588



**Mid back swivel
5-star polished aluminum base and arms
Adjustable height**

Swivel/tilt mechanism with adjustable height gas pneumatic lift

Outback standard with saddle stitch detail around the perimeter for fabric upholstered shells. Leather and leather alternative upholstered shells have saddle stitching accentuating the "V" detail on outback.

Inside seat width 20¾", Inside seat depth 17½", Inside arm height: 6¾"

SCS Indoor Advantage™ Gold and LEVEL® 2 certified. See terms and conditions for additional environmental information.

Seat Height	Arm Height	W	D	H	Fabric	Leather	Weight	Cubes/Qty
17¼-21¼"	24½-28½"	24¾"	24¼"	33¾-37¾"	1.75 yd	24.0'	50 lbs	28.98'/1
438-540 mm	622-724 mm	629 mm	616 mm	857-959 mm	1.6 m	2.2 sqm	22.7 kg	.82 cu

COM	COL	1	2	3	4	5	6	7	8	9	10	11
1844	1879	2008	2035	2051	2082	2109	2121	2140	2167	2191	2218	2373

I.a.m. 589



**Mid back swivel
5-star matte black powder coat base and arms
Adjustable height**

Swivel/tilt mechanism with adjustable height gas pneumatic lift

Outback standard with saddle stitch detail around the perimeter for fabric upholstered shells. Leather and leather alternative upholstered shells have saddle stitching accentuating the "V" detail on outback.

Inside seat width 20¾", Inside seat depth 17½", Inside arm height: 6¾"

SCS Indoor Advantage™ Gold and LEVEL® 2 certified. See terms and conditions for additional environmental information.

Seat Height	Arm Height	W	D	H	Fabric	Leather	Weight	Cubes/Qty
17¼-21¼"	24½-28½"	24¾"	24¼"	33¾-37¾"	1.75 yd	24.0'	50 lbs	28.98'/1
438-540 mm	622-724 mm	629 mm	616 mm	857-959 mm	1.6 m	2.2 sqm	22.7 kg	.82 cu

COM	COL	1	2	3	4	5	6	7	8	9	10	11
1994	2029	2158	2185	2201	2232	2259	2271	2290	2317	2341	2368	2523

lava 594



Swivel
5-star polished aluminum base
Molded polypropylene shell
Adjustable Height

Upholstered seat pad
 Molded polypropylene shell in Mist (RAL 7047)
 Swivel/tilt mechanism with adjustable height gas pneumatic lift

Inside seat width: 20½", Inside seat depth: 19", Inside arm height: 7½"

SCS Indoor Advantage™ Gold and LEVEL® 2 certified. See terms and conditions for additional environmental information.

Seat Height	Arm Height	W	D	H	Fabric	Leather	Weight	Cubes/Qty
18-22¼"	25¼-29½"	27⅞"	24½"	33¼"-37½"	1.0 yd	18.0'	41 lbs	28.98'/1
457-565 mm	641-749 mm	689 mm	622 mm	845-953 mm	.91 m	1.67 sqm	18.59 kg	.82 cu

COM	COL	1	2	3	4	5	6	7	8	9	10	11
1765	1785	1859	1874	1883	1901	1917	1923	1934	1950	1963	1979	2068

prelude 1577



Mid back swivel
5-star polished aluminum base
Upholstered
Adjustable height

Swivel/tilt mechanism with gas pneumatic lift

Inside seat width: 18¼", Inside seat depth: 17¼", Inside arm height: 7¾"

When using a combination of fabrics or leathers, specify the application by designating the appropriate letter, shown below, on the purchase order. Yardage shown must be used.

See terms and conditions for contrasting fabric and welt upcharges.

- A) One fabric or leather for seat
 yardage: 1.0 yds. leather: 16.5 sq. ft.
- B) One fabric or leather for inside back and outside back
 yardage: 2.75 yds. leather: 37.0 sq. ft.

All COM/COL fabrics must be preapproved by Bernhardt Design prior to application.

SCS Indoor Advantage™ Gold and LEVEL® 2 certified. See terms and conditions for additional environmental information.

Seat Height	Arm Height	W	D	H	Fabric	Leather	Weight	Cubes/Qty
17¼" - 20¼"	25¼-28⅞"	24⅞"	23⅞"	31-34"	3.75 yds.	53.0'	40.5 lbs.	22.04'/1
438-514 mm	638-714 mm	632 mm	600 mm	787-864 mm	3.43 m	4.46 sqm	18.15 kg.	.624 cu.

COM	COL	1	2	3	4	5	6	7	8	9	10	11
1560	1615	1817	1860	1884	1933	1976	1994	2025	2068	2104	2147	2392

sku

1	5	7	7										

base finish

- PA** polished aluminum standard, OR
- specify powder coat, upcharge \$150
- WH** satin white **GR** graphite **SG** sage green
- EC** ecru **BZ** bronze **RD** black red
- LA** latte **IG** iron grey **BK** matte black

renn 610



**Mid back swivel
5-star polished aluminum or powder coat base
Adjustable height**

Weight activated mechanism with adjustable height gas pneumatic lift

Inside seat width: 19¼"; Inside seat depth: 18¼", Inside arm height: 6⅝"

When using a combination of fabrics or leathers, specify the application by designating the appropriate letter, shown below, on the purchase order. Yardage shown must be used.

See terms and conditions for contrasting upholstery upcharges.

- A) One fabric or leather for seat
yardage: 1.5 yds. leather: 24.3 sq. ft.
- B) One fabric or leather for inback and outback
yardage: 1.5 yds. leather: 24.3 sq. ft.
- C) One fabric or leather for arm wrap
yardage: 1.5 yds. leather: 24.3 sq. ft.

SCS Indoor Advantage™ Gold certified. See terms and conditions for additional environmental information.

Seat Height	Arm Height	W	D	H	Fabric	Leather	Weight	Cubes/Qty
18¼"-21¼"	25½"-28½"	26"	27¼"	35¼"-38¼"	4.0 yds	65.0'	59 lbs.	29.59/1
476-552 mm	648-724 mm	660 mm	692 mm	895-972 mm	3.7 m	6.0 sqm	26.8 kg	.83 cu

COM	COL	1	2	3	4	5	6	7	8	9	10	11
1600	1680	1974	2036	2072	2143	2205	2232	2276	2338	2392	2454	2809

sku

6 | 1 | 0

base finish

- PA** polished aluminum standard, OR
- WH** satin white
- EC** ecru
- LA** latte
- GR** graphite
- BZ** bronze
- IG** iron grey
- SG** sage green
- RD** black red
- BK** matte black

specify powder coat, upcharge \$100

rice 558



**Mid back swivel
5-star polished aluminum base and arms
Adjustable height**

Loop arms with upholstered arm pads

Swivel/tilt mechanism with adjustable height gas pneumatic lift

Inside seat width: 20¼", Inside seat depth: 19⅝", Inside arm height: 6¼"

SCS Indoor Advantage™ Gold and LEVEL® 2 certified. See terms and conditions for additional environmental information.

Seat Height	Arm Height	W	D	H	Fabric	Leather	Weight	Cubes/Qty
18⅝"-21⅝"	24⅝"-27⅝"	25¼"	27⅝"	37⅝"-40⅝"	2.75 yd	45.0'	57 lbs	28.98/1
460-537 mm	619-695 mm	645 mm	708 mm	956-1032 mm	2.5 m	4.2 sqm	25.9 kg	.82 cu

COM	COL	1	2	3	4	5	6	7	8	9	10	11
2125	2180	2382	2425	2449	2498	2541	2559	2590	2633	2669	2712	2957

rice 559



**High back swivel
5-star polished aluminum base
Polished aluminum arms
Adjustable height**

Loop arms with upholstered arm pads
Swivel/tilt mechanism with adjustable height gas pneumatic lift

Inside seat width: 20¼", Inside seat depth: 19¾", Inside arm height: 6¾"

SCS Indoor Advantage™ Gold and LEVEL® 2 certified. See terms and conditions for additional environmental information.

Seat Height	Arm Height	W	D	H	Fabric	Leather	Weight	Cubes/Qty
18½-21½"	24¾-27¾"	25¼"	27¾"	40¾-43¾"	3.0 yd	52.7'	60 lbs	28.98'/1

460-537 mm	619-695 mm	645 mm	629 mm	1032-1108 mm	2.7 m	4.9 sqm	27.2 kg	.82 cu
------------	------------	--------	--------	--------------	-------	---------	---------	--------

COM	COL	1	2	3	4	5	6	7	8	9	10	11
2365	2425	2645	2692	2719	2772	2819	2839	2872	2919	2959	3005	3272

rice 560



**Mid back swivel
5-star polished aluminum base and arms
Adjustable height**

Loop arms with black neoprene arm pads
Swivel/tilt mechanism with adjustable height gas pneumatic lift

Inside seat width: 20¼", Inside seat depth: 19¾", Inside arm height: 6¾"

SCS Indoor Advantage™ Gold and LEVEL® 2 certified. See terms and conditions for additional environmental information.

Seat Height	Arm Height	W	D	H	Fabric	Leather	Weight	Cubes/Qty
18½-21½"	24¾-27¾"	25¼"	27¾"	37¾-40¾"	2.75 yd	45.0'	57 lbs	28.98'/1

460-537 mm	619-695 mm	645 mm	708 mm	956-1032 mm	2.5 m	4.2 sqm	25.9 kg	.82 cu
------------	------------	--------	--------	-------------	-------	---------	---------	--------

COM	COL	1	2	3	4	5	6	7	8	9	10	11
2036	2091	2293	2336	2360	2409	2452	2470	2501	2544	2580	2623	2868

rice 561



**High back swivel
5-star polished aluminum base
Polished aluminum arms
Adjustable height**

Loop arms with black neoprene arm pads
Swivel/tilt mechanism with adjustable height gas pneumatic lift

Inside seat width: 20¼", Inside seat depth: 19¾", Inside arm height: 6¾"

SCS Indoor Advantage™ Gold and LEVEL® 2 certified. See terms and conditions for additional environmental information.

Seat Height	Arm Height	W	D	H	Fabric	Leather	Weight	Cubes/Qty
18½"-21½"	24¾"-27¾"	25¾"	27¾"	40%-43½"	3.0 yd	52.7'	60 lbs	28.98'/1
460-537 mm	619-695 mm	645 mm	629 mm	1032-1108 mm	2.7 m	4.9 sqm	27.2 kg	.82 cu

COM	COL	1	2	3	4	5	6	7	8	9	10	11
2290	2350	2570	2617	2644	2697	2744	2764	2797	2844	2884	2930	3197

rice 562



**Mid back swivel
5-star black plastic base
Polished aluminum arms
Adjustable height**

Loop arms with upholstered arm pads
Swivel/tilt mechanism with gas pneumatic lift

Inside seat width: 20½", Inside seat depth: 18¾", Inside arm height: 6¾"

SCS Indoor Advantage™ Gold and LEVEL® 2 certified. See terms and conditions for additional environmental information.

Seat Height	Arm Height	W	D	H	Fabric	Leather	Weight	Cubes/Qty
18½"-21½"	24¾"-27¾"	25¾"	27¾"	37¾"-40½"	2.75 yd	45.0'	57 lbs	28.98'/1
460-537 mm	619-695 mm	645 mm	629 mm	956-1032 mm	2.5 m	4.2 sqm	25.9 kg	.82 cu

COM	COL	1	2	3	4	5	6	7	8	9	10	11
1874	1929	2131	2174	2198	2247	2290	2308	2339	2382	2418	2461	2706

rice 563



**High back swivel
5-star black plastic base
Polished aluminum arms
Adjustable height**

Loop arms with upholstered arm pads
Swivel/tilt mechanism with adjustable height gas pneumatic lift

Inside seat width: 20¼", Inside seat depth: 19%", Inside arm height: 6¾"

SCS Indoor Advantage™ Gold and LEVEL® 2 certified. See terms and conditions for additional environmental information.

Seat Height	Arm Height	W	D	H	Fabric	Leather	Weight	Cubes/Qty
18½"-21½"	24¾"-27¾"	25¾"	27¾"	40%-43%"	3.0 yd	52.7'	60 lbs	28.98'/1
460-537 mm	619-695 mm	645 mm	629 mm	1032-1108 mm	2.7 m	4.9 sqm	27.2 kg	.82 cu

COM	COL	1	2	3	4	5	6	7	8	9	10	11
2224	2284	2504	2551	2578	2631	2678	2698	2731	2778	2818	2864	3131

rice 564



**Mid back swivel
5-star black plastic base
Polished aluminum arms
Adjustable height**

Loop arms with black neoprene arm pads
Swivel/tilt mechanism with adjustable height gas pneumatic lift

Inside seat width: 20¼", Inside seat depth: 19%", Inside arm height: 6¾"

SCS Indoor Advantage™ Gold and LEVEL® 2 certified. See terms and conditions for additional environmental information.

Seat Height	Arm Height	W	D	H	Fabric	Leather	Weight	Cubes/Qty
18½"-21½"	24¾"-27¾"	25¾"	27¾"	37%-40%"	2.75 yd	45.0'	57 lbs	28.98'/1
460-537 mm	619-695 mm	645 mm	629 mm	956-1032 mm	2.5 m	4.2 sqm	25.9 kg	.82 cu

COM	COL	1	2	3	4	5	6	7	8	9	10	11
1800	1855	2057	2100	2124	2173	2216	2234	2265	2308	2344	2387	2632

rice 565



High back swivel
5-star black plastic base
Polished aluminum arms
Adjustable height

Loop arms with black neoprene arm pads
 Swivel/tilt mechanism with adjustable height gas pneumatic lift

Inside seat width: 20¼", Inside seat depth: 19%", Inside arm height: 6¾"

SCS Indoor Advantage™ Gold and LEVEL® 2 certified. See terms and conditions for additional environmental information.

Seat Height	Arm Height	W	D	H	Fabric	Leather	Weight	Cubes/Qty
18½"-21½"	24¾"-27¾"	25¼"	27¾"	40%-43½"	3.0 yd	52.7'	60 lbs	28.98'/1
460-537 mm	619-695 mm	645 mm	629 mm	1032-1108 mm	2.7 m	4.9 sqm	27.2 kg	.82 cu

COM	COL	1	2	3	4	5	6	7	8	9	10	11
2152	2212	2432	2479	2506	2559	2606	2626	2659	2706	2746	2792	3059

valera 608C



Mid back swivel
5-star polished aluminum or powder coat base
Oak veneer back
Upholstered seat
Adjustable height

Tilt mechanism with adjustable height gas pneumatic lift.

Inside seat width: 20", Inside seat depth: 18", Inside arm height: 7½"

Available in all oak finishes. When specifying light finishes the natural characteristics of the wood will be visible and color will vary.

SCS Indoor Advantage™ Gold and Level 2 certified. See terms and conditions for additional environmental information.

Seat Height	Arm Height	W	D	H	Fabric	Leather	Weight	Cubes/Qty
17½" - 20½"	24¾"-27¾"	24¾"	22¾"	29¾"-32¾"	1.0 yd	18.0' sq. ft.	38 lbs	29.0'/1
445-521 mm	632-708 mm	632 mm	581 mm	746-822 mm	.92 m	1.7 sqm	17.3 kg	.82 cu

COM	COL	1	2	3	4	5	6	7	8	9	10	11
1680	1700	1774	1789	1798	1816	1832	1838	1849	1865	1878	1894	1983

sku

6 | 0 | 8 | C |

base finish

- PA** polished aluminum standard, OR
- specify powder coat, upcharge \$100
- WH** satin white **GR** graphite **RD** black red
- EC** ecru **BZ** bronze **BK** matte black
- LA** latte **IG** iron grey

valera 608W



Mid back swivel
5-star polished aluminum or powder coat base
Walnut veneer back
Upholstered seat
Adjustable height

Tilt mechanism with adjustable height gas pneumatic lift.

Inside seat width: 20", Inside seat depth: 18", Inside arm height: 7½"

Available in all walnut finishes. When specifying light finishes the natural characteristics of the wood will be visible and color will vary.

SCS Indoor Advantage™ Gold and Level 2 certified. See terms and conditions for additional environmental information.

Seat Height	Arm Height	W	D	H	Fabric	Leather	Weight	Cubes/Qty
17½" - 20½"	24⅞"-27⅞"	24⅞"	22⅞"	29⅞"-32⅞"	1.0 yd	18.0' sq. ft.	38 lbs	29.0'/1
445-521 mm	632-708 mm	632 mm	581 mm	746-822 mm	.92 m	1.7 sqm	17.3 kg	.82 cu

COM	COL	1	2	3	4	5	6	7	8	9	10	11
1784	1804	1878	1893	1902	1920	1936	1942	1953	1969	1982	1998	2087

sku

6 0 8 W

base finish

PA polished aluminum standard, OR		
specify powder coat, upcharge \$100		
WH satin white	GR graphite	RD black red
EC ecru	BZ bronze	BK matte black
LA latte	IG iron grey	

anne 1890



Solid walnut frame
Available in natural oiled LV8 finish only
Leather or suede seat with flange stitch

Not recommended for high-use areas.

SCS Indoor Advantage™ Gold and LEVEL® 2 certified. See terms and conditions for additional finish and environmental information.

Seat Height	Arm Height	W	D	H	Fabric	Leather	Weight	Cubes/Qty
16½"	27¼"	25½"	25"	29½"	-	12.5'	25 lbs	22.25'/1
419 mm	705 mm	651 mm	635 mm	749 mm	-	1.1 sqm	11.4 kg	.63 cu

List Price
5003

avant 1995



Polished stainless steel frame
Upholstered

Flange detail on the inside back of the chair
 Standard vertical application of fabric with stripes

SCS Indoor Advantage™ Gold and LEVEL® 2 certified. See terms and conditions for additional environmental information.

Seat Height	Arm Height	W	D	H	Fabric	Leather	Weight	Cubes/Qty
17½"	24¾"	21¼"	23¾"	31½"	1.75 yds	32.5'	33 lbs	22.25'/1
445 mm	629 mm	552 mm	604 mm	800 mm	1.6 m	3.0 sqm	15.0 kg	.63 cu

COM	COL	1	2	3	4	5	6	7	8	9	10	11
1558	1593	1722	1749	1765	1796	1823	1835	1854	1881	1905	1932	2087

avant 1996



Brushed nickel frame
Upholstered

Front to back stretcher
 Flange detail on the inside back of the chair
 Standard vertical application of fabric with stripes

SCS Indoor Advantage™ Gold and LEVEL® 2 certified. See terms and conditions for additional environmental information.

Seat Height	Arm Height	W	D	H	Fabric	Leather	Weight	Cubes/Qty
17½"	-	19¾"	2 ¾"	31½"	1.75 yds	32.5'	34 lbs	28.78'/2
445 mm	-	498 mm	644 mm	800 mm	1.6 m	3.0 sqm	15.4 kg	.81 cu

COM	COL	1	2	3	4	5	6	7	8	9	10	11
1386	1421	1550	1577	1593	1624	1651	1663	1682	1709	1733	1760	1915

blitz 1585U



**Armless chair
Solid ash frame
Upholstered seat pad**

Available only with upholstered seat pad

Frame available in all ash finishes. When specifying light finishes the natural characteristics of the wood will be visible and color will vary.

Inside seat width: 16 7/8", Inside seat depth: 17 1/2"

SCS Indoor Advantage™ Gold certified. See terms and conditions for additional finish and environmental information.

NOTE: The Blitz chair is non-stackable. Damages to the chair will occur if the chair is stacked.

Seat Height	Arm Height	W	D	H	Fabric	Leather	Weight	Cubes/Qty
18 1/2"	-	19 7/8"	20 1/4"	30 3/4"	1.0 yd	18.0'	30 lbs.	21.35'/1
470 mm	-	505 mm	514 mm	781 mm	.91 m	1.7 sqm	13.6 kg	.6 cu.

COM	COL	1	2	3	4	5	6	7	8	9	10	11
1196	1216	1290	1305	1314	1332	1348	1354	1365	1381	1394	1410	1499

capri 1714



**Solid maple frame
Upholstered seat**

Available in all maple finishes. When specifying light finishes the natural characteristics of the wood will be visible and color will vary.

SCS Indoor Advantage™ Gold and LEVEL® 2 certified. See terms and conditions for additional finish and environmental information.

Seat Height	Arm Height	W	D	H	Fabric	Leather	Weight	Cubes/Qty
19"	23 3/4"-29 1/4"	23"	22 1/2"	33 1/2"	1.0 yds	14.0'	28 lbs	22.25'/1
483 mm	606-743 mm	584 mm	572 mm	826 mm	.91 m	1.3 sqm	12.7 kg	.63 cu

COM	COL	1	2	3	4	5	6	7	8	9	10	11
2190	2210	2284	2299	2308	2326	2342	2348	2359	2375	2388	2404	2493

capri 1715



**Solid walnut frame
Upholstered seat**

Available in all walnut finishes. When specifying light finishes the natural characteristics of the wood will be visible and color will vary.

SCS Indoor Advantage™ Gold and LEVEL® 2 certified. See terms and conditions for additional finish and environmental information.

Seat Height	Arm Height	W	D	H	Fabric	Leather	Weight	Cubes/Qty
19"	23 3/4"-29 1/4"	23"	22 1/2"	33 1/2"	1.0 yds	14.0'	28 lbs	22.25'/1
483 mm	606-743 mm	584 mm	572 mm	826 mm	.91 m	1.3 sqm	12.7 kg	.63 cu

COM	COL	1	2	3	4	5	6	7	8	9	10	11
2855	2875	2949	2964	2973	2991	3007	3013	3024	3040	3053	3069	3158

celon 1525



**Brushed stainless steel frame
Upholstered**

Solids and leather will be seamed on the seat and inside back.
Certain mohair, thick or heavy piled fabrics are not suitable for this product.

SCS Indoor Advantage™ Gold and LEVEL® 2 certified. See terms and conditions for additional environmental information.

Seat Height	Arm Height	W	D	H	Fabric	Leather	Weight	Cubes/Qty
18½"	24¾"	23"	23¾"	31½"	2.75 yds	36.0'	50 lbs	22.25'/1
460 mm	629 mm	584 mm	603 mm	800 mm	2.5 m	3.3 sqm	22.7 kg	.63 cu

COM	COL	1	2	3	4	5	6	7	8	9	10	11
3237	3292	3494	3537	3561	3610	3653	3671	3702	3745	3781	3824	4069

celon 1526



**Polished stainless steel frame
Upholstered**

Solids and leather will be seamed on the seat and inside back.
Certain mohair, thick or heavy piled fabrics are not suitable for this product.

SCS Indoor Advantage™ Gold and LEVEL® 2 certified. See terms and conditions for additional environmental information.

Seat Height	Arm Height	W	D	H	Fabric	Leather	Weight	Cubes/Qty
18½"	24¾"	23"	23¾"	31½"	2.75 yds	36.0'	50 lbs	22.25'/1
460 mm	629 mm	584 mm	603 mm	800 mm	2.5 m	3.3 sqm	22.7 kg	.63 cu

COM	COL	1	2	3	4	5	6	7	8	9	10	11
3453	3508	3710	3753	3777	3826	3869	3887	3918	3961	3997	4040	4285

chantal 1023



**Tubular polished stainless steel or powder coat base
Upholstered**

Molded foam over nylon shell

When using a combination of fabrics or leathers, specify the application by designating the appropriate letter, shown below, on the purchase order. Yardage shown must be used.

See terms and conditions for contrasting upholstery upcharges.

- A) One fabric or leather for seat
yardage: 1.0 yds. leather: 15.0 sq. ft.
- B) One fabric or leather for inside and outside back, sides and inside arms
yardage: 2.5 yds. leather: 40.5 sq. ft.

SCS Indoor Advantage™ Gold and LEVEL® 2 certified. See terms and conditions for additional environmental information.

Seat Height	Arm Height	W	D	H	Fabric	Leather	Weight	Cubes/Qty
19"	26"	24"	25"	33½"	3.0 yds	40.0'	38 lbs	21.74/1
483 mm	660 mm	610 mm	635 mm	851 mm	2.7 m	3.7 sqm	17.2 kg	.62 cu

COM	COL	1	2	3	4	5	6	7	8	9	10	11
1462	1522	1742	1789	1816	1869	1916	1936	1969	2016	2056	2102	2369

sku

1 0 2 3

base finish

polished stainless steel standard, OR

specify powder coat, upcharge \$100

WH satin white	IG iron grey
GR graphite	RD black red
BZ bronze	K matte black

--	--	--

chantal 1024



**Polished aluminum or powder coat base
Upholstered**

Molded foam over nylon shell

When using a combination of fabrics or leathers, specify the application by designating the appropriate letter, shown below, on the purchase order. Yardage shown must be used.

See terms and conditions for contrasting upholstery upcharges.

- A) One fabric or leather for seat
yardage: 1.0 yds. leather: 15.0 sq. ft.
- B) One fabric or leather for inside and outside back, sides and inside arms
yardage: 2.5 yds. leather: 40.5 sq. ft.

SCS Indoor Advantage™ Gold and LEVEL® 1 certified. See terms and conditions for additional environmental information.

Seat Height	Arm Height	W	D	H	Fabric	Leather	Weight	Cubes/Qty
19"	26"	24"	25"	33½"	3.0 yds	40.0'	38 lbs	21.74'/1
483 mm	660 mm	610 mm	635 mm	851 mm	2.7 m	3.7 sqm	17.2 kg	.62 cu

COM	COL	1	2	3	4	5	6	7	8	9	10	11
1676	1736	1956	2003	2030	2083	2130	2150	2183	2230	2270	2316	2583

sku

1	0	2	4	

base finish

polished aluminum standard, OR

specify powder coat, upcharge \$100

WH satin white	IG iron grey
GR graphite	RD black red
BZ bronze	K matte black

chantal 1026M



**Solid maple base
Upholstered**

Available in all maple finishes. When specifying light finishes the natural characteristics of the wood will be visible and color will vary.

When using a combination of fabrics or leathers, specify the application by designating the appropriate letter, shown below, on the purchase order. Yardage shown must be used.

See terms and conditions for contrasting upholstery upcharges.

- A) One fabric or leather for seat
yardage: 1.0 yds. leather: 15.0 sq. ft.
- B) One fabric or leather for inside and outside back, sides and inside arms
yardage: 2.5 yds. leather: 40.5 sq. ft.

SCS Indoor Advantage™ Gold and LEVEL® 1 certified. See terms and conditions for additional finish and environmental information.

Seat Height	Arm Height	W	D	H	Fabric	Leather	Weight	Cubes/Qty
19"	26"	24"	25"	33½"	3.0 yds	40.0'	38 lbs	21.74'/1
483 mm	660 mm	610 mm	635 mm	851 mm	2.7 m	3.7 sqm	17.2 kg	.62 cu

COM	COL	1	2	3	4	5	6	7	8	9	10	11
2306	2366	2586	2633	2660	2713	2760	2780	2813	2860	2900	2946	3213

charlotte 1717



**Solid walnut frame
Upholstered seat pad**

Available in all walnut finishes. When specifying light finishes the natural characteristics of the wood will be visible and color will vary.

SCS Indoor Advantage™ Gold and LEVEL® 1 certified. See terms and conditions for additional finish and environmental information.

Seat Height	Arm Height	W	D	H	Fabric	Leather	Weight	Cubes/Qty
18¼"	24¾"	23"	23¾"	31¾"	1.0 yds	14.0'	30 lbs	22.25/1
464 mm	625 mm	584 mm	594 mm	810 mm	.91 m	1.3 sqm	13.6 kg	.63 cu

COM	COL	1	2	3	4	5	6	7	8	9	10	11
2660	2680	2754	2769	2778	2796	2812	2818	2829	2845	2858	2874	2963

chloe 1020



**Tubular polished stainless steel or powder coat base
Upholstered**

Molded foam over nylon shell

When using a combination of fabrics or leathers, specify the application by designating the appropriate letter, shown below, on the purchase order. Yardage shown must be used.

See terms and conditions for contrasting upholstery upcharges.

- A) One fabric or leather for seat
yardage: 1.0 yds. leather: 15.0 sq. ft.
- B) One fabric or leather for inside and outside back
yardage: 2.0 yds. leather: 35.0 sq. ft.

SCS Indoor Advantage™ Gold and LEVEL® 2 certified. See terms and conditions for additional environmental information.

Seat Height	Arm Height	W	D	H	Fabric	Leather	Weight	Cubes/Qty
19"	-	20¼"	24¾"	32½"	2.25 yds	35.0'	37 lbs	21.74/1
483 mm	-	514 mm	629 mm	826 mm	2.1 m	3.3 sqm	16.8 kg	.62 cu

COM	COL	1	2	3	4	5	6	7	8	9	10	11
1150	1195	1360	1395	1415	1455	1490	1505	1530	1565	1595	1630	1830

sku

1	0	2	0										

base finish

polished stainless steel standard, OR	
specify powder coat, upcharge \$100	
WH satin white	IG iron grey
GR graphite	RD black red
BZ bronze	K matte black

chloe 1021



**Polished aluminum or powder coat base
Upholstered**

Molded foam over nylon shell

When using a combination of fabrics or leathers, specify the application by designating the appropriate letter, shown below, on the purchase order. Yardage shown must be used.

See terms and conditions for contrasting upholstery upcharges.

- A) One fabric or leather for seat
yardage: 1.0 yds. leather: 15.0 sq. ft.
- B) One fabric or leather for inside and outside back
yardage: 2.0 yds. leather: 35.0 sq. ft.

SCS Indoor Advantage™ Gold and LEVEL® 2 certified. See terms and conditions for additional environmental information.

Seat Height	Arm Height	W	D	H	Fabric	Leather	Weight	Cubes/Qty
19"	-	20¼"	24¾"	32½"	2.25 yds	35.0'	37 lbs	21.74/1
483 mm	-	514 mm	629 mm	826 mm	2.1 m	3.3 sqm	16.8 kg	.62 cu

COM	COL	1	2	3	4	5	6	7	8	9	10	11
1344	1389	1554	1589	1609	1649	1684	1699	1724	1759	1789	1824	2024

sku

1	0	2	1									

base finish

polished aluminum standard, OR

specify powder coat, upcharge \$100

WH satin white	IG iron grey
GR graphite	RD black red
BZ bronze	K matte black

--	--	--	--	--	--	--	--	--	--	--	--	--

chloe 1019M



**Solid maple base
Upholstered**

Molded foam over nylon shell.

Available in all maple finishes. When specifying light finishes the natural characteristics of the wood will be visible and color will vary.

When using a combination of fabrics or leathers, specify the application by designating the appropriate letter, shown below, on the purchase order. Yardage shown must be used.

See terms and conditions for contrasting upholstery upcharges.

- A) One fabric or leather for seat
yardage: 1.0 yds. leather: 15.0 sq.ft.
- B) One fabric or leather for inside and outside back
yardage: 2.0 yds. leather: 35.0 sq.ft.

SCS Indoor Advantage™ Gold and LEVEL® 2 certified. See terms and conditions for additional finish and environmental information.

Seat Height	Arm Height	W	D	H	Fabric	Leather	Weight	Cubes/Qty
18¼"	-	20¼"	24¾"	32½"	2.25 yds	35.0'	30 lbs	22.25/1
464mm	-	514 mm	629 mm	826 mm	2.1 m	3.3 sqm	13.6 kg	.63 cu

COM	COL	1	2	3	4	5	6	7	8	9	10	11
1937	1982	2147	2182	2202	2242	2277	2292	2317	2352	2382	2417	2617

claris 1605



**Solid maple base
Upholstered**

Welt standard along bottom edge of seat

Available in all maple finishes. When specifying light finishes the natural characteristics of the wood will be visible and color will vary.

When using a combination of fabrics or leathers, specify the application by designating the appropriate letter, shown below, on the purchase order. Yardage shown must be used.

See terms and conditions for contrasting upholstery and welt upcharges.

- A) One fabric or leather for seat and inside back
yardage: 1.8 yds. leather: 24.0 sq. ft.
- B) One fabric or leather for outside back, sides, inside arms, front panel and welt
yardage: 2.5 yds. leather: 33.75 sq. ft.

SCS Indoor Advantage™ Gold and LEVEL® 2 certified. See terms and conditions for additional finish and environmental information.

Seat Height	Arm Height	W	D	H	Fabric	Leather	Weight	Cubes/Qty
19¼"	24½"	23¾"	24⅞"	32¾"	4.4 yds	60.0'	44 lbs	22.25/1
489 mm	622 mm	603 mm	632 mm	832 mm	4.0 m	5.6 sqm	20.0 kg	.63 cu

COM	COL	1	2	3	4	5	6	7	8	9	10	11
2271	2359	2682	2751	2790	2868	2936	2966	3015	3083	3142	3210	3601

cooper 1570



Solid ash frame

Inside width: 18¾"; Inside depth: 18½"

Available in all ash finishes. When specifying light finishes the natural characteristics of the wood will be visible and color will vary.

SCS Indoor Advantage™ Gold and LEVEL® 2 Certified. See terms and conditions for additional environmental information.

Seat Height	Arm Height	W	D	H	Fabric	Leather	Weight	Cubes/Qty
18 1/8"	27 1/2"	22 1/8"	21"	30 5/8"	-	-	34 lbs	21.35'/1
460 mm	699 mm	562 mm	533 mm	778 mm	-	-	15.4 kg	.6 cu

List Price
1404

cooper 1570U



**Solid ash frame
Upholstered seat pad**

Inside width: 18¾"; Inside depth: 18½"

Available in all ash finishes. When specifying light finishes the natural characteristics of the wood will be visible and color will vary.

SCS Indoor Advantage™ Gold and LEVEL® 2 Certified. See terms and conditions for additional finish and environmental information.

Seat Height	Arm Height	W	D	H	Fabric	Leather	Weight	Cubes/Qty
18 5/8"	27 1/2"	22 1/8"	21"	30 5/8"	1.0 yds	18.0'	34 lbs	21.35'/1
473 mm	699 mm	562 mm	533 mm	778 mm	.91 m	1.67 sqm	15.4 kg	.6 cu

COM	COL	1	2	3	4	5	6	7	8	9	10	11
1508	1528	1602	1617	1626	1644	1660	1666	1677	1693	1706	1722	1811

corvo 1710



**Solid maple frame
Upholstered seat**

Available in all maple finishes. When specifying light finishes the natural characteristics of the wood will be visible and color will vary.

SCS Indoor Advantage™ Gold and LEVEL® 2 certified. See terms and conditions for additional finish and environmental information.

Seat Height	Arm Height	W	D	H	Fabric	Leather	Weight	Cubes/Qty
18¾"	27½"	22¾"	21"	29"	1.0 yds	12.5'	24.8 lbs	22.25'/1
476 mm	699 mm	578 mm	533 mm	737 mm	0.9 m	1.2 sqm	11.2 kg	.63 cu

COM	COL	1	2	3	4	5	6	7	8	9	10	11
2253	2273	2347	2362	2371	2389	2405	2411	2422	2438	2451	2467	2556

corvo 1711



**Solid walnut frame
Upholstered seat**

Available in all walnut finishes. When specifying light finishes the natural characteristics of the wood will be visible and color will vary.

SCS Indoor Advantage™ Gold and LEVEL® 2 certified. See terms and conditions for additional finish and environmental information.

Seat Height	Arm Height	W	D	H	Fabric	Leather	Weight	Cubes/Qty
18¾"	27½"	22¾"	21"	29"	1.0 yds	12.5'	24.8 lbs	22.25'/1
476 mm	699 mm	578 mm	533 mm	737 mm	0.9 m	1.2 sqm	11.2 kg	.63 cu

COM	COL	1	2	3	4	5	6	7	8	9	10	11
2933	2953	3027	3042	3051	3069	3085	3091	3102	3118	3131	3147	3236

glasgow 6492

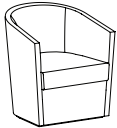

**Stationary chair
Fully upholstered**

When using a combination of fabrics or leathers, specify the application by designating the appropriate letter, shown below, on the purchase order. Yardage shown must be used.

See terms and conditions for contrasting upholstery upcharges.

- A) One fabric or leather for seat
yardage: 1.0 yds. leather: 32.4 sq. ft.
- B) One fabric or leather for inside and outside back, sides, inside arms and front panel
yardage: 4.25 yds. leather: 56.7 sq. ft.

SCS Indoor Advantage™ Gold and LEVEL® 2 certified. See terms and conditions for additional environmental information.

Seat Height	Arm Height	W	D	H	Fabric	Leather	Weight	Cubes/Qty
17½"	25½"	27¾"	25¾"	30½"	5.0 yds	75.0'	65 lbs	22.69'/1
435 mm	648 mm	695 mm	651 mm	765 mm	4.6 m	7.0 sqm	29.5 kg	.64 cu

COM	COL	1	2	3	4	5	6	7	8	9	10	11
2338	2438	2805	2883	2927	3016	3094	3127	3183	3261	3327	3405	3850

glasgow 6493

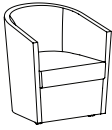

**Chair with casters
Fully upholstered**

When using a combination of fabrics or leathers, specify the application by designating the appropriate letter, shown below, on the purchase order. Yardage shown must be used.

See terms and conditions for contrasting upholstery upcharges.

- A) One fabric or leather for seat
yardage: 1.0 yds. leather: 32.4 sq. ft.
- B) One fabric or leather for inside and outside back, sides, inside arms and front panel
yardage: 4.25 yds. leather: 56.7 sq. ft.

SCS Indoor Advantage™ Gold and LEVEL® 2 certified. See terms and conditions for additional environmental information.

Seat Height	Arm Height	W	D	H	Fabric	Leather	Weight	Cubes/Qty
17½"	25½"	27½"	25½"	30½"	5.0 yds	75.0'	65 lbs	22.69/1
435 mm	648 mm	695 mm	651 mm	765 mm	4.6 m	7.0 sqm	29.5 kg	.64 cu

COM	COL	1	2	3	4	5	6	7	8	9	10	11
2496	2596	2963	3041	3085	3174	3252	3285	3341	3419	3485	3563	4008

glasgow 6494

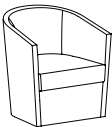

**Self-return swivel
Fully upholstered**

When using a combination of fabrics or leathers, specify the application by designating the appropriate letter, shown below, on the purchase order. Yardage shown must be used.

See terms and conditions for contrasting upholstery upcharges.

- A) One fabric or leather for seat
yardage: 1.0 yds. leather: 32.4 sq. ft.
- B) One fabric or leather for inside and outside back, sides, inside arms and front panel
yardage: 4.25 yds. leather: 56.7 sq. ft.

SCS Indoor Advantage™ Gold and LEVEL® 2 certified. See terms and conditions for additional environmental information.

Seat Height	Arm Height	W	D	H	Fabric	Leather	Weight	Cubes/Qty
17½"	25½"	27½"	25½"	30½"	5.0 yds	75.0'	71 lbs	22.69/1
435 mm	648 mm	695 mm	651 mm	765 mm	4.6 m	7.0 sqm	32.2 kg	.64 cu

COM	COL	1	2	3	4	5	6	7	8	9	10	11
2741	2841	3208	3286	3330	3419	3497	3530	3586	3664	3730	3808	4253

go® 1011SG/1011SW



**Stacking chair
Silver powder coated magnesium frame**

- 1011SG** Gray polypropylene seat
- 1011SW** White polypropylene seat

Stacks two high
US Design Patent No. D446,960.

Seat Height	Arm Height	W	D	H	Fabric	Leather	Weight	Cubes/Qty
18"	25"	23"	27"	30½"	-	-	35 lbs	17.08/1
457 mm	635 mm	584 mm	686 mm	775 mm	-	-	15.9 kg	.48 cu

List Price
2591

halo 1106



**Stacking chair
Solid ash frame
Ash veneer seat and back**

Stacks four high
When used with stacking cart 1105, Halo stacks eight high

Available in all ash finishes. When specifying light finishes the natural characteristics of the wood will be visible and color will vary.

SCS Indoor Advantage™ Gold and LEVEL® 2 certified. See terms and conditions for additional finish and environmental information.

Seat Height	Arm Height	W	D	H	Fabric	Leather	Weight	Cubes/Qty
18¼"	-	21¼"	19½"	30¾"	-	-	26 lbs	22.25/1
464 mm	-	540 mm	495 mm	784 mm	-	-	11.8 kg	.63 cu

List Price
1048

halo 1108



**Solid ash frame
Upholstered seat and back**

Available in all ash finishes. When specifying light finishes the natural characteristics of the wood will be visible and color will vary.

Not recommended for stacking.

When using a combination of fabrics or leathers, specify the application by designating the appropriate letter, shown below, on the purchase order. Yardage shown must be used.

See terms and conditions for contrasting upholstery upcharges.

- A) One fabric or leather for seat
yardage: 1.0 yd. leather: 18.0 sq. ft.
- B) One fabric or leather for back
yardage: 1.0 yd. leather: 18.0 sq. ft.

SCS Indoor Advantage™ Gold and LEVEL® 2 certified. See terms and conditions for additional finish and environmental information.

Seat Height	Arm Height	W	D	H	Fabric	Leather	Weight	Cubes/Qty
18¼"	-	21¼"	19½"	31"	1.25 yds	25.0'	28 lbs	22.25/1
464 mm	-	540 mm	495 mm	787 mm	1.1 m	2.3 sqm	12.7 kg	.63 cu

COM	COL	1	2	3	4	5	6	7	8	9	10	11
1196	1221	1313	1333	1344	1366	1385	1394	1408	1427	1444	1463	1574

helium 1712



**Solid maple frame
Upholstered**

Available in all maple finishes. When specifying light finishes the natural characteristics of the wood will be visible and color will vary.

When using a combination of fabrics or leathers, specify the application by designating the appropriate letter, shown below, on the purchase order. Yardage shown must be used.

See terms and conditions for contrasting upholstery upcharges.

- A) One fabric or leather for seat
yardage: 1.0 yds. leather: 15.0 sq. ft.
- B) One fabric or leather for back
yardage: 1.25 yds. leather: 21.0 sq. ft.

SCS Indoor Advantage™ Gold and LEVEL® 2 certified. See terms and conditions for additional finish and environmental information.

Seat Height	Arm Height	W	D	H	Fabric	Leather	Weight	Cubes/Qty
18¼"	25"	22¼"	25¼"	32"	1.5 yds	27.0'	25.5 lbs	34.77'/2
464 mm	635 mm	565 mm	654 mm	813 mm	1.4 m	2.5 sqm	11.6 kg	.98 cu

COM	COL	1	2	3	4	5	6	7	8	9	10	11
1758	1788	1898	1922	1935	1962	1985	1995	2012	2035	2055	2078	2212

matinee 1200



Solid oak frame

Inside seat width: 17½", Inside seat depth: 17¼", Inside arm height: 10"

Available in all oak finishes. When specifying light finishes the natural characteristics of the wood will be visible and color will vary.

SCS Indoor Advantage™ Gold and LEVEL® 2 certified. See terms and conditions for additional finish and environmental information.

Seat Height	Arm Height	W	D	H	Fabric	Leather	Weight	Cubes/Qty
17½"	28¾"	21¼"	21¼"	31½"	-	-	37 lbs	21.35'/1
445 mm	721 mm	552 mm	552 mm	800 mm	-	-	16.8 kg	.6 cu

List Price
1045

matinee 1201



**Solid oak frame
Upholstered seat pad**

Inside seat width: 17½", Inside seat depth: 17½", Inside arm height: 9"

Available in all oak finishes. When specifying light finishes the natural characteristics of the wood will be visible and color will vary.

SCS Indoor Advantage™ Gold and LEVEL® 2 certified. See terms and conditions for additional finish and environmental information.

Seat Height	Arm Height	W	D	H	Fabric	Leather	Weight	Cubes/Qty
18¼"	2¾"	21¼"	21¼"	31½"	1.0 yds	18.0'	37 lbs	21.35/1
464 mm	721 mm	552 mm	552 mm	800 mm	.9 m	1.7 sqm	16.8 kg	.6 cu

COM	COL	1	2	3	4	5	6	7	8	9	10	11
1149	1169	1243	1258	1267	1285	1301	1307	1318	1334	1347	1363	1452

monza 1209-40

PLANK



**Outdoor stacking chair
Solid iroko frame
Polypropylene backrest**

Stacks four high
When used with stacking cart 1700-00, Monza stacks four high

Solid iroko wooden structure, oil treated. For care and cleaning of outdoor Plank products, see Care and Cleaning - Plank within terms and conditions.

ANSI/BIFMA certified.

Linking device 1209-90 available in Accessories.

Seat Height	Arm Height	W	D	H	Fabric	Leather	Weight	Cubes/Qty
17 3/4"	25 1/4"	21 1/4"	19 1/4"	30 3/8"	-	-	21 lbs.	9.88/1
451 mm	642 mm	540 mm	489 mm	772 mm	-	-	9.5 kg	.28 cu.

List Price
1403

sku	backrest color	frame material	glides																										
1 2 0 9 - 4 0	<table border="0"> <tr> <td>01</td> <td>black</td> <td>13</td> <td>wine red</td> </tr> <tr> <td>02</td> <td>white</td> <td>32</td> <td>terra brown</td> </tr> <tr> <td>03</td> <td>traffic red</td> <td>33</td> <td>café latte</td> </tr> <tr> <td>06</td> <td>yellow green</td> <td>34</td> <td>caramel</td> </tr> <tr> <td>08</td> <td>light blue</td> <td></td> <td></td> </tr> </table>	01	black	13	wine red	02	white	32	terra brown	03	traffic red	33	café latte	06	yellow green	34	caramel	08	light blue			<table border="0"> <tr> <td>IR</td> <td>iroko</td> </tr> </table>	IR	iroko	<table border="0"> <tr> <td>ST</td> <td>standard</td> </tr> <tr> <td>TL</td> <td>teflon</td> </tr> </table>	ST	standard	TL	teflon
01	black	13	wine red																										
02	white	32	terra brown																										
03	traffic red	33	café latte																										
06	yellow green	34	caramel																										
08	light blue																												
IR	iroko																												
ST	standard																												
TL	teflon																												
		I R																											

monza 1209-40 ash

PLANK



**Stacking chair
Solid ash frame
Polypropylene backrest**

Stacks four high
When used with stacking cart 1700-00, Monza stacks four high

Available in Plank ash finishes. When specifying light finishes the natural characteristics of the wood will be visible and color will vary.

ANSI/BIFMA certified.

Linking device 1209-90 available in Accessories.

Seat Height	Arm Height	W	D	H	Fabric	Leather	Weight	Cubes/Qty
17 3/4"	25 1/4"	21 1/4"	19 1/4"	30 3/8"	-	-	20 lbs.	9.88/1
451 mm	642 mm	540 mm	489 mm	772 mm	-	-	9.1 kg	.28 cu.

List Price

1073

sku

backrest color

frame finish

glides

1	2	0	9	-	4	0
---	---	---	---	---	---	---

01	black	13	wine red
02	white	32	terra brown
03	traffic red	33	café latte
06	yellow green	34	caramel
08	light blue		

AN	ash natural
AB	ash black
AWH	ash white

ST	standard
FT	felt
TL	teflon

monza 1209-40 walnut

PLANK



**Stacking chair
Solid walnut frame
Polypropylene backrest**

Stacks four high
When used with stacking cart 1700-00, Monza stacks four high

Available in Plank canaletto walnut natural finish.

ANSI/BIFMA certified.

Linking device 1209-90 available in Accessories.

Seat Height	Arm Height	W	D	H	Fabric	Leather	Weight	Cubes/Qty
17 3/4"	25 1/4"	21 1/4"	19 1/4"	30 3/8"	-	-	20 lbs.	9.88'/1
451 mm	642 mm	540 mm	489 mm	772 mm	-	-	9.1 kg	.28 cu.

List Price

1563

sku

backrest color

frame finish

glides

1	2	0	9	-	4	0
---	---	---	---	---	---	---

01	black	13	wine red
02	white	32	terra brown
03	traffic red	33	café latte
06	yellow green	34	caramel
08	light blue		

WLT	canaletto
	walnut natural

ST	standard
FT	felt
TL	teflon

monza 1209-40 oak

PLANK



Stacking chair
Solid oak frame
Polypropylene backrest

Stacks four high
 When used with stacking cart 1700-00, Monza stacks four high

Available in Plank oak natural finish. When specifying light finishes the natural characteristics of the wood will be visible and color will vary.

ANSI/BIFMA certified.

Linking device 1209-90 available in Accessories.

Seat Height	Arm Height	W	D	H	Fabric	Leather	Weight	Cubes/Qty
17 3/4"	25 1/4"	21 1/4"	19 1/4"	30 3/8"	-	-	20 lbs.	9.88/1
451 mm	642 mm	540 mm	489 mm	772 mm	-	-	9.1 kg	.28 cu.

List Price

1153

sku

backrest color

frame finish

glides

1	2	0	9	-	4	0
---	---	---	---	---	---	---

01	black	13	wine red
02	white	32	terra brown
03	traffic red	33	café latte
06	yellow green	34	caramel
08	light blue		

OAK	oak natural
-----	-------------

ST	standard
FT	felt
TL	teflon

monza 1209-40-98 ash

PLANK



Stacking chair
Solid ash frame
Polypropylene backrest
Upholstered seat cushion

Stacks four high
When used with stacking cart 1700-00, Monza stacks four high

Available in Plank ash finishes. When specifying light finishes the natural characteristics of the wood will be visible and color will vary.

Available in Plank approved textiles only.

ANSI/BIFMA certified.

Linking device 1209-90 available in Accessories.

Seat Height	Arm Height	W	D	H	Fabric	Leather	Weight	Cubes/Qty
18 1/2"	25 1/4"	21 1/4"	19 1/4"	30 3/8"	1.0 yds	20.0'	20 lbs.	9.88/1
470 mm	642 mm	540 mm	489 mm	772 mm	.92 m	1.9 sqm	9.5 kg	.28 cu.

COM/GRP1	GRP2	GRP3	GRP4	GRP5
1300	1346	1369	1403	1438

sku	backrest material	frame finish	fabric	glides																																					
1 2 0 9 - 4 0 - 9 8	<table border="0"> <tr> <td>01</td> <td>black</td> <td>13</td> <td>wine red</td> </tr> <tr> <td>02</td> <td>white</td> <td>32</td> <td>terra brown</td> </tr> <tr> <td>03</td> <td>traffic red</td> <td>33</td> <td>café latte</td> </tr> <tr> <td>06</td> <td>yellow green</td> <td>34</td> <td>caramel</td> </tr> <tr> <td>08</td> <td>light blue</td> <td></td> <td></td> </tr> </table>	01	black	13	wine red	02	white	32	terra brown	03	traffic red	33	café latte	06	yellow green	34	caramel	08	light blue			<table border="0"> <tr> <td>AN</td> <td>ash natural</td> </tr> <tr> <td>AB</td> <td>ash black</td> </tr> <tr> <td>AWH</td> <td>ash white</td> </tr> </table>	AN	ash natural	AB	ash black	AWH	ash white	<table border="0"> <tr> <td>COM/GRP1</td> </tr> <tr> <td>GRP2</td> </tr> <tr> <td>GRP3</td> </tr> <tr> <td>GRP4</td> </tr> <tr> <td>GRP5</td> </tr> </table>	COM/GRP1	GRP2	GRP3	GRP4	GRP5	<table border="0"> <tr> <td>ST</td> <td>standard</td> </tr> <tr> <td>FT</td> <td>felt</td> </tr> <tr> <td>TL</td> <td>teflon</td> </tr> </table>	ST	standard	FT	felt	TL	teflon
01	black	13	wine red																																						
02	white	32	terra brown																																						
03	traffic red	33	café latte																																						
06	yellow green	34	caramel																																						
08	light blue																																								
AN	ash natural																																								
AB	ash black																																								
AWH	ash white																																								
COM/GRP1																																									
GRP2																																									
GRP3																																									
GRP4																																									
GRP5																																									
ST	standard																																								
FT	felt																																								
TL	teflon																																								

monza 1209-40-98 walnut

PLANK



Stacking chair
Solid walnut frame
Polypropylene backrest
Upholstered seat cushion

Stacks four high
 When used with stacking cart 1700-00, Monza stacks four high

Available in Plank canaletto walnut natural finish.

Available in Plank approved textiles only.

ANSI/BIFMA certified.

Linking device 1209-90 available in Accessories.

Seat Height	Arm Height	W	D	H	Fabric	Leather	Weight	Cubes/Qty
18 1/2"	25 1/4"	21 1/4"	19 1/4"	30 3/8"	1.0 yds	20.0'	20 lbs.	9.88'/1
470 mm	642 mm	540 mm	489 mm	772 mm	.92 m	1.9 sqm	9.1 kg	.28 cu.

COM/GRP1	GRP2	GRP3	GRP4	GRP5
1790	1836	1859	1893	1927

sku	backrest color	frame finish	fabric	glides
1 2 0 9 - 4 0 - 9 8	01 black	13 wine red	WLT canaletto walnut natural	COM/GRP1 ST standard
	02 white	32 terra brown		GRP2 FT felt
	03 traffic red	33 café latte		GRP3 TL teflon
	06 yellow green	34 caramel		GRP4
	08 light blue			GRP5
		W L T		

monza 1209-40-98 oak

PLANK



Stacking chair
Solid oak frame
Polypropylene backrest
Upholstered seat cushion

Stacks four high
 When used with stacking cart 1700-00, Monza stacks four high

Available in Plank oak natural finish. When specifying light finishes the natural characteristics of the wood will be visible and color will vary.

Available in Plank approved textiles only.

ANSI/BIFMA certified.

Linking device 1209-90 available in Accessories.

Seat Height	Arm Height	W	D	H	Fabric	Leather	Weight	Cubes/Qty
18 1/2"	25 1/4"	21 1/4"	19 1/4"	30 3/8"	1.0 yds	20.0'	20 lbs.	9.88/1
470 mm	642 mm	540 mm	489 mm	772 mm	.92 m	1.9 sqm	9.1 kg	.28 cu.

COM/GRP1	GRP2	GRP3	GRP4	GRP5
1381	1426	1449	1482	1517

sku	backrest material	frame finish	fabric	glides																															
1 2 0 9 - 4 0 - 9 8	<table border="0"> <tr> <td>01</td> <td>black</td> <td>13</td> <td>wine red</td> </tr> <tr> <td>02</td> <td>white</td> <td>32</td> <td>terra brown</td> </tr> <tr> <td>03</td> <td>traffic red</td> <td>33</td> <td>café latte</td> </tr> <tr> <td>06</td> <td>yellow green</td> <td>34</td> <td>caramel</td> </tr> <tr> <td>08</td> <td>light blue</td> <td></td> <td></td> </tr> </table>	01	black	13	wine red	02	white	32	terra brown	03	traffic red	33	café latte	06	yellow green	34	caramel	08	light blue			OAK oak natural	<table border="0"> <tr> <td>COM/GRP1</td> </tr> <tr> <td>GRP2</td> </tr> <tr> <td>GRP3</td> </tr> <tr> <td>GRP4</td> </tr> <tr> <td>GRP5</td> </tr> </table>	COM/GRP1	GRP2	GRP3	GRP4	GRP5	<table border="0"> <tr> <td>ST</td> <td>standard</td> </tr> <tr> <td>FT</td> <td>felt</td> </tr> <tr> <td>TL</td> <td>teflon</td> </tr> </table>	ST	standard	FT	felt	TL	teflon
01	black	13	wine red																																
02	white	32	terra brown																																
03	traffic red	33	café latte																																
06	yellow green	34	caramel																																
08	light blue																																		
COM/GRP1																																			
GRP2																																			
GRP3																																			
GRP4																																			
GRP5																																			
ST	standard																																		
FT	felt																																		
TL	teflon																																		
		O A K																																	

monza 1209-40-99

PLANK



Outdoor stacking chair
Solid iroko frame
Polypropylene backrest
Removable upholstered seat cushion

Stacks four high
 When used with stacking cart 1700-00, Monza stacks four high

Solid iroko wooden structure, oil treated. For care and cleaning of outdoor Plank products, see Care and Cleaning-Plank within terms and conditions.

Available in Plank approved textiles only.

ANSI/BIFMA certified.

Linking device 1209-90 available in Accessories.

Seat Height	Arm Height	W	D	H	Fabric	Leather	Weight	Cubes/Qty
17 3/4"	25 1/4"	21 1/4"	19 1/4"	30 3/8"	1.0 yds	20.0'	21 lbs.	9.88/1
451 mm	642 mm	540 mm	489 mm	772 mm	.92 m	1.9 sqm	9.5 kg	.28 cu.

COM/GRP1	GRP2	GRP3	GRP4	GRP5
1687	0	1767	0	0

sku	backrest material	frame finish	fabric	glides																				
1 2 0 9 - 4 0 - 9 9	<table border="0"> <tr> <td>01</td><td>black</td> <td>13</td><td>wine red</td> </tr> <tr> <td>02</td><td>white</td> <td>32</td><td>terra brown</td> </tr> <tr> <td>03</td><td>traffic red</td> <td>33</td><td>café latte</td> </tr> <tr> <td>06</td><td>yellow green</td> <td>34</td><td>caramel</td> </tr> <tr> <td>08</td><td>light blue</td> <td></td><td></td> </tr> </table>	01	black	13	wine red	02	white	32	terra brown	03	traffic red	33	café latte	06	yellow green	34	caramel	08	light blue			IR iroko	COM/GRP1 GRP3	ST standard TL teflon
01	black	13	wine red																					
02	white	32	terra brown																					
03	traffic red	33	café latte																					
06	yellow green	34	caramel																					
08	light blue																							

monza 1209-40-99 ash

PLANK



Stacking chair
Solid ash frame
Polypropylene backrest
Removable upholstered seat cushion

Stacks four high
 When used with stacking cart 1700-00, Monza stacks four high

Available in Plank ash finishes. When specifying light finishes the natural characteristics of the wood will be visible and color will vary.

Available in Plank approved textiles only.

ANSI/BIFMA certified.

Linking device 1209-90 available in Accessories.

Seat Height	Arm Height	W	D	H	Fabric	Leather	Weight	Cubes/Qty
17 3/4"	25 1/4"	21 1/4"	19 1/4"	30 3/8"	1.0 yds	20.0'	20 lbs.	9.88/1
451 mm	642 mm	540 mm	489 mm	772 mm	.92 m	1.9 sqm	9.1 kg	.28 cu.

COM/GRP1	GRP2	GRP3	GRP4	GRP5
1358	1369	1438	1482	1505

sku	backrest material	frame finish	fabric	glides																																					
1 2 0 9 - 4 0 - 9 9	<table border="0"> <tr> <td>01</td> <td>black</td> <td>13</td> <td>wine red</td> </tr> <tr> <td>02</td> <td>white</td> <td>32</td> <td>terra brown</td> </tr> <tr> <td>03</td> <td>traffic red</td> <td>33</td> <td>café latte</td> </tr> <tr> <td>06</td> <td>yellow green</td> <td>34</td> <td>caramel</td> </tr> <tr> <td>08</td> <td>light blue</td> <td></td> <td></td> </tr> </table>	01	black	13	wine red	02	white	32	terra brown	03	traffic red	33	café latte	06	yellow green	34	caramel	08	light blue			<table border="0"> <tr> <td>AN</td> <td>ash natural</td> </tr> <tr> <td>AB</td> <td>ash black</td> </tr> <tr> <td>AWH</td> <td>ash white</td> </tr> </table>	AN	ash natural	AB	ash black	AWH	ash white	<table border="0"> <tr> <td>COM/GRP1</td> </tr> <tr> <td>GRP2</td> </tr> <tr> <td>GRP3</td> </tr> <tr> <td>GRP4</td> </tr> <tr> <td>GRP5</td> </tr> </table>	COM/GRP1	GRP2	GRP3	GRP4	GRP5	<table border="0"> <tr> <td>ST</td> <td>standard</td> </tr> <tr> <td>FT</td> <td>felt</td> </tr> <tr> <td>TL</td> <td>teflon</td> </tr> </table>	ST	standard	FT	felt	TL	teflon
01	black	13	wine red																																						
02	white	32	terra brown																																						
03	traffic red	33	café latte																																						
06	yellow green	34	caramel																																						
08	light blue																																								
AN	ash natural																																								
AB	ash black																																								
AWH	ash white																																								
COM/GRP1																																									
GRP2																																									
GRP3																																									
GRP4																																									
GRP5																																									
ST	standard																																								
FT	felt																																								
TL	teflon																																								

monza 1209-40-99 walnut

PLANK



Stacking chair
Solid walnut frame
Polypropylene backrest
Removable upholstered seat cushion

Stacks four high
 When used with stacking cart 1700-00, Monza stacks four high

Available in Plank canaletto walnut natural finish.

Available in Plank approved textiles only.

ANSI/BIFMA certified.

Linking device 1209-90 available in Accessories.

Seat Height	Arm Height	W	D	H	Fabric	Leather	Weight	Cubes/Qty
17 3/4"	25 1/4"	21 1/4"	19 1/4"	30 3/8"	1.0 yds	20.0'	20 lbs.	9.88'/1
451 mm	642 mm	540 mm	489 mm	772 mm	.92 m	1.9 sqm	9.1 kg	.28 cu.

COM/GRP1	GRP2	GRP3	GRP4	GRP5
1848	1859	1927	1972	1995

sku	backrest color	frame finish	fabric	glides
1 2 0 9 - 4 0 - 9 9	01 black	13 wine red	WLT canaletto walnut natural	COM/GRP1 ST standard
	02 white	32 terra brown		GRP2 FT felt
	03 traffic red	33 café latte		GRP3 TL teflon
	06 yellow green	34 caramel		GRP4
	08 light blue			GRP5
		W L T		

monza 1209-40-99 oak

PLANK



Stacking chair
Solid oak frame
Polypropylene backrest
Removable upholstered seat cushion

Stacks four high
 When used with stacking cart 1700-00, Monza stacks four high

Available in Plank oak natural finish. When specifying light finishes the natural characteristics of the wood will be visible and color will vary.

Available in Plank approved textiles only.

ANSI/BIFMA certified.

Linking device 1209-90 available in Accessories.

Seat Height	Arm Height	W	D	H	Fabric	Leather	Weight	Cubes/Qty
17 3/4"	25 1/4"	21 1/4"	19 1/4"	30 3/8"	1.0 yds	20.0'	21 lbs.	9.88/1
451 mm	642 mm	540 mm	489 mm	772 mm	.92 m	1.9 sqm	9.5 kg	.28 cu.

COM/GRP1	GRP2	GRP3	GRP4	GRP5
1438	1449	1517	1563	1585

sku	backrest material	frame finish	fabric	glides																															
1 2 0 9 - 4 0 - 9 9	<table border="0"> <tr> <td>01</td> <td>black</td> <td>13</td> <td>wine red</td> </tr> <tr> <td>02</td> <td>white</td> <td>32</td> <td>terra brown</td> </tr> <tr> <td>03</td> <td>traffic red</td> <td>33</td> <td>café latte</td> </tr> <tr> <td>06</td> <td>yellow green</td> <td>34</td> <td>caramel</td> </tr> <tr> <td>08</td> <td>light blue</td> <td></td> <td></td> </tr> </table>	01	black	13	wine red	02	white	32	terra brown	03	traffic red	33	café latte	06	yellow green	34	caramel	08	light blue			OAK oak natural	<table border="0"> <tr> <td>COM/GRP1</td> </tr> <tr> <td>GRP2</td> </tr> <tr> <td>GRP3</td> </tr> <tr> <td>GRP4</td> </tr> <tr> <td>GRP5</td> </tr> </table>	COM/GRP1	GRP2	GRP3	GRP4	GRP5	<table border="0"> <tr> <td>ST</td> <td>standard</td> </tr> <tr> <td>FT</td> <td>felt</td> </tr> <tr> <td>TL</td> <td>teflon</td> </tr> </table>	ST	standard	FT	felt	TL	teflon
01	black	13	wine red																																
02	white	32	terra brown																																
03	traffic red	33	café latte																																
06	yellow green	34	caramel																																
08	light blue																																		
COM/GRP1																																			
GRP2																																			
GRP3																																			
GRP4																																			
GRP5																																			
ST	standard																																		
FT	felt																																		
TL	teflon																																		
		O A K																																	

mulholland 1571



**Solid ash frame
Upholstered**

Nylon glides

Inside Width: 20³/₈", Inside Depth: 18³/₄"

Available in all ash finishes. When specifying light finishes the natural characteristics of the wood will be visible and color will vary.

When using a combination of fabrics or leathers, specify the application by designating the appropriate letter, shown below, on the purchase order. Yardage shown must be used.

See terms and conditions for contrasting upholstery upcharges.

- A) One fabric or leather for seat cushion
yardage: 1.0 yd. leather: 18.0 sq. ft.
- B) One fabric or leather for inside and outside back
yardage: 3.5 yds. leather: 45.0 sq. ft.

SCS Indoor Advantage™ Gold and LEVEL® 2 certified. See terms and conditions for additional environmental information.

Seat Height	Arm Height	W	D	H	Fabric	Leather	Weight	Cubes/Qty
19"	10"	23 ¹ / ₄ "	22 ¹ / ₂ "	30 ³ / ₄ "	4.5 yds.	63.0'	41 lbs.	12.35/1
483 mm	254 mm	591 mm	572 mm	781 mm	4.12 m	5.86 sqm	18.6 kg	.61 cu.

COM	COL	1	2	3	4	5	6	7	8	9	10	11
2056	2146	2476	2546	2586	2666	2736	2766	2816	2886	2946	3016	3416

myto 1207-20

PLANK



**Cantilever stacking chair
Polypropylene frame
Indoor and outdoor use**

Stacks eight high
When used with stacking cart 1730-00, Myto stacks eight high

Recyclable. ANSI/BIFMA certified. For care and cleaning of outdoor Plank products, see Care and Cleaning - Plank within terms and conditions.

Seat Height	Arm Height	W	D	H	Fabric	Leather	Weight	Cubes/Qty
18 1/8"	-	20 1/8"	21 5/8"	32 1/4"	-	-	17 lbs.	12/1
461 mm	-	508 mm	550 mm	820 mm	-	-	7.7 kg	.34 cu.

List Price
606

sku

frame color

glides

1	2	0	7	-	2	0
---	---	---	---	---	---	---

01	black	04	pure orange
02	white	06	yellow green
03	traffic red	08	light blue

ST	standard
FT	felt

neve 1718C



**Solid oak frame
Upholstered seat pad**

Frame available in all oak finishes. When specifying light finishes the natural characteristics of the wood will be visible and color will vary.

Inside Seat Width: 18", Inside Seat Depth: 18¾"

SCS Indoor Advantage™ Gold and LEVEL® 2 certified. See terms and conditions for additional environmental information.

Seat Height	Arm Height	W	D	H	Fabric	Leather	Weight	Cubes/Qty
18"	26¼"	22 5/8"	20¾"	30 3/4"	1.0 yds	18.0'	30 lbs	21.35/1
457 mm	667 mm	730 mm	527 mm	781 mm	.91 m	1.67 sqm	13.6 kg	.61 cu

COM	COL	1	2	3	4	5	6	7	8	9	10	11
1664	1684	1758	1773	1782	1800	1816	1822	1833	1849	1862	1878	1967

neve 1718W



**Solid walnut frame
Upholstered seat pad**

Frame available in all walnut finishes. When specifying light finishes the natural characteristics of the wood will be visible and color will vary.

Inside Seat Width: 18", Inside Seat Depth: 18¾"

SCS Indoor Advantage™ Gold and LEVEL® 2 certified. See terms and conditions for additional environmental information.

Seat Height	Arm Height	W	D	H	Fabric	Leather	Weight	Cubes/Qty
18"	26¼"	22 5/8"	20 3/4"	30 3/4"	1.0 yds	18.0'	30 lbs	21.35/1
457 mm	667 mm	575 mm	527 mm	781 mm	.91 m	1.67 sqm	13.6 kg	.61 cu

COM	COL	1	2	3	4	5	6	7	8	9	10	11
1976	1996	2070	2085	2094	2112	2128	2134	2145	2161	2174	2190	2279

orbit® wood 1101



**Stacking chair
Chrome base
Ash veneer seat**

Gray stacking bumper
Stacks six high
When used with stacking cart 1105, Orbit® stacks 10 high

Available in all ash finishes. When specifying light finishes the natural characteristics of the wood will be visible and color will vary.

SCS Indoor Advantage™ Gold and LEVEL® 2 certified. See terms and conditions for additional finish and environmental information.

Seat Height	Arm Height	W	D	H	Fabric	Leather	Weight	Cubes/Qty
17½"	-	21½"	21½"	31"	-	-	16 lbs	20.99/4
445 mm	-	546 mm	546 mm	787 mm	-	-	7.2 kg	.59 cu

List Price
1742

orbit® wood 1102



**Stacking chair
Chrome base
Zebra wood veneer seat**

Gray stacking bumper
Stacks six high
When used with stacking cart 1105, Orbit® stacks 10 high

Available in zebra wood finishes only. When specifying light finishes the natural characteristics of the wood will be visible and color will vary.

SCS Indoor Advantage™ Gold and LEVEL® 2 certified. See terms and conditions for additional finish and environmental information.

Seat Height	Arm Height	W	D	H	Fabric	Leather	Weight	Cubes/Qty
17½"	-	21½"	21½"	31"	-	-	16 lbs	20.99/4
445 mm	-	546 mm	546 mm	787 mm	-	-	7.2 kg	.59 cu

List Price
1922

orbit® 1103



**Stacking chair
Chrome base
Plastic seat**

Gray stacking bumper
Stacks six high
When used with stacking cart 1105, Orbit® stacks 10 high

SCS Indoor Advantage™ Gold and LEVEL® 2 certified. See terms and conditions for additional environmental information.

Seat Height	Arm Height	W	D	H	Fabric	Leather	Weight	Cubes/Qty
17½"	-	21½"	21½"	31"	-	-	16 lbs	20.99/4
445 mm	-	546 mm	546 mm	787 mm	-	-	7.2 kg	.59 cu

List Price
821

sku

1	1	0	3		

seat

- G** dark gray plastic
- R** red plastic
- W** white plastic

prelude 1574



**Polished stainless steel or powder coat frame
Upholstered**

Non-marring glides

Inside seat depth: 17"

When using a combination of fabrics or leathers, specify the application by designating the appropriate letter, shown below, on the purchase order. Yardage shown must be used.

See terms and conditions for contrasting upholstery upcharges.

- A) One fabric or leather for seat
yardage: 1.0 yds. leather: 18.0 sq. ft
- B) One fabric or leather for inside and outside back
yardage: 1.75 yds. leather: 29.0 sq. ft.

SCS Indoor Advantage™ Gold and LEVEL® 2 certified. See terms and conditions for additional finish and environmental information.

Seat Height	Arm Height	W	D	H	Fabric	Leather	Weight	Cubes/Qty
18 3/8"	-	19"	20 7/8"	32"	2.25 yds	37.0'	30 lbs.	22.69'/1
467 mm	-	483 mm	530 mm	813 mm	2.1 m	3.4 sqm	14.0 kg.	.64 cu.

COM	COL	1	2	3	4	5	6	7	8	9	10	11
1150	1195	1360	1395	1415	1455	1490	1505	1530	1565	1595	1630	1830

sku

1	5	7	4										

powder coat finish

PA polished stainless steel standard, OR		
specify powder coat, upcharge \$125		
WH satin white	GR graphite	SG sage green
EC ecru	BZ bronze	RD black red
LA latte	IG iron grey	BK matte black

prelude 1575



**Solid ash base
Upholstered**

Inside seat width: 18 3/4"; Inside seat depth: 18 1/4"

Available in all ash finishes. When specifying light finishes the natural characteristics of the wood will be visible and color will vary.

When using a combination of fabrics or leathers, specify the application by designating the appropriate letter, shown below, on the purchase order. Yardage shown must be used.

See terms and conditions for contrasting upholstery upcharges..

- A) One fabric or leather for seat cushion
yardage: 1.0 yds. leather: 16.5 sq. ft.
- B) One fabric or leather for inside and outside back
yardage: 2.75 yds. leather: 37.0 sq. ft.

SCS Indoor Advantage™ Gold and LEVEL® 2 certified. See terms and conditions for additional finish and environmental information.

Seat Height	Arm Height	W	D	H	Fabric	Leather	Weight	Cubes/Qty
19"	28 1/4"	24 3/8"	22 5/8"	32 3/4"	2.75 yds.	53.0'	37.5 lbs.	22.17/1
483 mm	718 mm	620 mm	575 mm	832 mm	2.5 m	4.2 sqm	17.0 kg.	.628 cu.

COM	COL	1	2	3	4	5	6	7	8	9	10	11
1800	1855	2057	2100	2124	2173	2216	2234	2265	2308	2344	2387	2632

prelude 1576



**Polished stainless steel or powder coat base
Upholstered**

Non-marring glides

Inside seat width: 18 3/4"; Inside seat depth: 18 1/4"

When using a combination of fabrics or leathers, specify the application by designating the appropriate letter, shown below, on the purchase order. Yardage shown must be used.

See terms and conditions for contrasting upholstery upcharges.

- A) One fabric or leather for seat
yardage: 1.0 yds. leather: 16.5 sq. ft.
- B) One fabric or leather for inside and outside back
yardage: 2.75 yds. leather: 37.0 sq. ft.

SCS Indoor Advantage™ Gold and LEVEL® 2 certified. See terms and conditions for additional finish and environmental information.

Seat Height	Arm Height	W	D	H	Fabric	Leather	Weight	Cubes/Qty
19"	26 1/4"	24 3/8"	22 5/8"	32 3/4"	2.75 yds	53.0'	34 lbs.	28.33/1
483 mm	667 mm	620 mm	575 mm	832 mm	2.5 m	4.2 sqm	15.4 kg.	.8 cu.

COM	COL	1	2	3	4	5	6	7	8	9	10	11
1350	1405	1607	1650	1674	1723	1766	1784	1815	1858	1894	1937	2182

sku

1	5	7	6									

powder coat finish

PA polished stainless steel standard, OR		
specify powder coat, upcharge \$125		
WH satin white	GR graphite	SG sage green
EC ecru	BZ bronze	RD black red
LA latte	IG iron grey	BK matte black

queue 1037



Monobloc stacking chair
Polypropylene frame
Upholstered seat

Stacks four high in a pinwheel formation
 Pile fabrics are not recommended for stackable applications

SCS Indoor Advantage™ Gold and LEVEL® 2 certified. See terms and conditions for additional environmental information.

Seat Height	Arm Height	W	D	H	Fabric	Leather	Weight	Cubes/Qty
19 5/8"	-	17 5/8"	19 1/2"	31"	3/4 yds	15.0'	38 lbs	28.77/2
486 mm	-	448 mm	495 mm	787 mm	.34 m	1.4 sqm	17.3 kg	.81 cu

COM	COL	1	2	3	4	5	6	7	8	9	10	11
372	387	442	454	461	474	486	491	499	511	521	532	599

sku

1	0	3	7
---	---	---	---

frame

S	slate blue
E	sienna
B	blush
T	tobacco
W	white

remo 1415-10

PLANK



Ash veneer seat and base

Available in Plank ash finishes. When specifying light finishes the natural characteristics of the wood will be visible and color will vary.

Not recommended for stacking.

Seat Height	Arm Height	W	D	H	Fabric	Leather	Weight	Cubes/Qty
17 3/4"	-	20 1/2"	18 7/8"	30 3/4"	-	-	17 lbs.	12/1
451 mm	-	521 mm	480 mm	762 mm	-	-	7.7 kg	.34 cu.

List Price

1084

sku

1	4	1	5	-	1	0
---	---	---	---	---	---	---

seat and base finish

AC	ash chalk
AN	ash natural
AG	ash grey
AW	ash walnut
AB	ash black

glides

ST	standard
FT	felt

remo 1415-10-99

PLANK



Ash veneer seat and base
Upholstered seat cushion

Available in Plank ash finishes. When specifying light finishes the natural characteristics of the wood will be visible and color will vary.

Not recommended for stacking.

Available in Plank approved textiles only.

Seat Height	Arm Height	W	D	H	Fabric	Leather	Weight	Cubes/Qty
18 1/2"	-	20 1/2"	18 7/8"	30 3/4"	1.0 yds	20.0'	17 lbs.	12'/1
470 mm	-	521 mm	480 mm	762 mm	.92 m	1.9 sqm	7.7 kg	.34 cu.

COM/GRP1	GRP2	GRP3	GRP4	GRP5
1312	1358	1381	1415	1449

sku	seat and base finish	fabric	glides
	AC ash chalk AN ash natural AG ash grey AW ash walnut AB ash black	COM/GRP1 GRP2 GRP3 GRP4 GRP5	ST standard FT felt
1 4 1 5 - 1 0 - 9 9			

remo 1415-20

PLANK



Stacking chair
Ash veneer seat and base

Stacks four high
When used with stacking cart 1700-00, Remo stacks four high

Available in Plank ash finishes. When specifying light finishes the natural characteristics of the wood will be visible and color will vary.

Seat Height	Arm Height	W	D	H	Fabric	Leather	Weight	Cubes/Qty
17 3/4"	-	20 1/2"	18 7/8"	30 3/4"	-	-	17 lbs.	12'/1
451 mm	-	521 mm	480 mm	762 mm	-	-	7.7 kg	.34 cu.

List Price
1084

sku	seat and base finish	glides
	AC ash chalk AN ash natural AG ash grey AW ash walnut AB ash black	ST standard FT felt
1 4 1 5 - 2 0		

remo 1415-20-99

PLANK



Stacking chair
Ash veneer seat and base
Upholstered seat cushion

Stacks four high
 When used with stacking cart 1700-00, Remo stacks four high

Available in Plank ash finishes. When specifying light finishes the natural characteristics of the wood will be visible and color will vary.

Available in Plank approved textiles only.

Seat Height	Arm Height	W	D	H	Fabric	Leather	Weight	Cubes/Qty
18 1/2"	-	20 1/2"	18 7/8"	30 3/4"	1.0 yds	20.0'	17 lbs.	12/1
470 mm	-	521 mm	480 mm	762 mm	.92 m	1.9 sqm	7.7 kg	.34 cu.

COM/GRP1	GRP2	GRP3	GRP4	GRP5
1312	1358	1381	1415	1449

sku

seat and base finish

fabric

glides

1	4	1	5	-	2	0	-	9	9
---	---	---	---	---	---	---	---	---	---

AN	ash natural
AC	ash chalk
AW	ash walnut
AB	ash black
AG	ash grey

COM/GRP1
GRP2
GRP3
GRP4
GRP5

ST	standard
FT	felt

remo 1416-20

PLANK



Stacking chair
Ash veneer seat
Stainless steel powder coat base

Stacks 12 high
 When used with stacking cart 1700-00, Remo stacks 12 high

Available in Plank ash finishes. When specifying light finishes the natural characteristics of the wood will be visible and color will vary.

Stainless steel base matched to seat finish.

ANSI/BIFMA certified.

Seat Height	Arm Height	W	D	H	Fabric	Leather	Weight	Cubes/Qty
17 3/4"	-	21 5/8"	18 7/8"	30 3/4"	-	-	18 lbs.	12/1
451 mm	-	550 mm	480 mm	762 mm	-	-	8.2 kg	.34 cu.

List Price

799

sku

seat finish

base finish

glides

1	4	1	1	6	-	2	0
---	---	---	---	---	---	---	---

AN	ash natural
AWH	ash white
AG	ash grey
AB	ash black
AY	ash yellow

22	beige
02	white
20	signal grey
01	black
24	sulfur yellow

ST	standard
FT	felt

remo 1416-20-99

PLANK



Stacking chair
Ash veneer seat
Stainless steel powder coat base
Upholstered seat cushion

Stacks eight high
 When used with stacking cart 1700-00, Remo stacks 8 high

Available in Plank ash finishes. When specifying light finishes the natural characteristics of the wood will be visible and color will vary.

Stainless steel base matched to seat finish.

Available in Plank approved textiles only.

ANSI/BIFMA certified.

Seat Height	Arm Height	W	D	H	Fabric	Leather	Weight	Cubes/Qty
18 1/2"	-	21 5/8"	18 7/8"	30 3/4"	1.0 yds	20.0'	17 lbs.	12'/1
470 mm	-	550 mm	480 mm	762 mm	.92 m	1.9 sqm	7.7 kg	.34 cu.

COM/GRP1	GRP2	GRP3	GRP4	GRP5
1027	1073	1096	1130	1164

sku	seat finish	base finish	fabric	glides
1 4 1 6 - 2 0 - 9 9	AN ash natural AWH ash white AG ash grey AB ash black AY ash yellow	22 beige 02 white 20 signal grey 01 black 24 sulfur yellow	COM/GRP1 GRP2 GRP3 GRP4 GRP5	ST standard FT felt

remo 1417-20

PLANK



Stacking chair
Polypropylene seat
Chrome or powder coat base
Indoor and outdoor use (powder coat only)

Stacks 12 high
 When used with stacking cart 1750-00, Remo stacks ten high.

ANSI/BIFMA certified.

Seat Height	Arm Height	W	D	H	Fabric	Leather	Weight	Cubes/Qty
17 3/4"	-	21 5/8"	18 7/8"	30 3/4"	-	-	18 lbs.	9.88/1
451 mm	-	550 mm	480 mm	762 mm	-	-	8.2 kg	.28 cu.

List Price
515

sku	seat finish	base finish	glides
1 4 1 7 - 2 0	01 black	27 pastel green	ST standard
	02 white	28 basalt grey	FT felt
	10 oxide red	29 green blue	
	20 signal grey	30 avion blue	
	24 sulfur yellow	31 coral red	
	25 yellow grey		
	26 fern green		
	01 black	27 pastel green	
	02 white	28 basalt grey	
	10 oxide red	29 green blue	
	20 signal grey	30 avion blue	
	24 sulfur yellow	31 coral red	
	25 yellow grey	CH chrome	
	26 fern green	(indoor only)	

remo 1417-20-99

PLANK



Stacking chair
Polypropylene seat
Chrome or powder coat base
Upholstered seat cushion

Stacks 8 high
 When used with stacking cart 1750-00, Remo stacks 8 high.

Available in Plank approved textiles only.

ANSI/BIFMA certified.

Seat Height	Arm Height	W	D	H	Fabric	Leather	Weight	Cubes/Qty
18 1/2"	-	21 5/8"	18 7/8"	30 3/4"	1.0 yds	20.0'	18 lbs.	9.88/1
470 mm	-	550 mm	480 mm	762 mm	.92 m	1.9 sqm	8.2 kg	.28 cu.

COM/GRP1	GRP2	GRP3	GRP4	GRP5
743	789	811	845	879

sku	seat finish	base finish	fabric	glides
1 4 1 7 - 2 0 - 9 9	01 black	27 pastel green	COM/GRP1	ST standard
	02 white	28 basalt grey	GRP2	FT felt
	10 oxide red	29 green blue	GRP3	
	20 signal grey	30 avion blue	GRP4	
	24 sulfur yellow	31 coral red	GRP5	
	25 yellow grey			
	26 fern green			
	01 black	27 pastel green		
	02 white	28 basalt grey		
	10 oxide red	29 green blue		
	20 signal grey	30 avion blue		
	24 sulfur yellow	31 coral red		
	25 yellow grey	CH chrome		
	26 fern green	(indoor only)		

remo 1418-20

PLANK



Stacking chair
Black powder coat base
Upholstered molded polypropylene seat and back

Stacks six high
 When used with stacking cart 1750-00, Remo stacks 6 high.

Available in Plank approved textiles only.

Seat Height	Arm Height	W	D	H	Fabric	Leather	Weight	Cubes/Qty
18 1/8"	-	21 5/8"	18 7/8"	31 1/8"	1.5 yds	-	19 lbs.	9.88'/1
461 mm	-	550 mm	480 mm	791 mm	1.4 m	-	8.6 kg	.28 cu.

COM/GRP1	GRP2	GRP3	GRP4	GRP5
1179	1229	1279	1328	0

sku	frame finish	fabric	glides
1 4 1 8 - 2 0	01 black	COM/GRP1 GRP2 GRP3 GRP4	ST standard FT felt
	0 1		

session 1615



Solid maple frame
Upholstered seat and back

Available in all maple finishes. When specifying light finishes the natural characteristics of the wood will be visible and color will vary.

SCS Indoor Advantage™ Gold and LEVEL® 2 certified. See terms and conditions for additional finish and environmental information.

Seat Height	Arm Height	W	D	H	Fabric	Leather	Weight	Cubes/Qty
18 1/4"	24 1/2"	21 1/8"	22 1/8"	32 1/4"	2.0 yds	27.0'	28 lbs	34.77'/2
464 mm	622 mm	556 mm	562 mm	819 mm	1.8 m	2.5 sqm	12.7 kg	.98 cu

COM	COL	1	2	3	4	5	6	7	8	9	10	11
1520	1560	1707	1738	1756	1792	1823	1836	1858	1889	1916	1947	2125

sonar 1126/1126B



**Stacking chair
Exposed maple back and seat**

1126 Polished chrome base
1126B Matte black powder coat base

Stacks six high
When used with stacking cart 1105, Sonar stacks 7 high

Available in all maple finishes. When specifying light finishes the natural characteristics of the wood will be visible and color will vary.

SCS Indoor Advantage™ Gold and LEVEL® 2 certified. See terms and conditions for additional finish and environmental information.

Seat Height	Arm Height	W	D	H	Fabric	Leather	Weight	Cubes/Qty
18"	-	21"	21½"	31½"	-	-	16 lbs	20.99/4
457 mm	-	553 mm	546 mm	800 mm	-	-	7.3 kg	.59 cu

List Price
1092

sonar 1126U/1126UB



**Stacking chair
Exposed maple back
Upholstered seat**

1126U Polished chrome base
1126UB Matte black powder coat base

Stacks six high
When used with stacking cart 1105, Sonar stacks 7 high

Available in all maple finishes. When specifying light finishes the natural characteristics of the wood will be visible and color will vary.

SCS Indoor Advantage™ Gold and LEVEL® 2 certified. See terms and conditions for additional finish and environmental information.

Seat Height	Arm Height	W	D	H	Fabric	Leather	Weight	Cubes/Qty
18"	-	21"	21½"	31½"	1.0 yds	17.0'	16 lbs	20.99/3
457 mm	-	553 mm	546 mm	800 mm	.92 m	1.6 sqm	7.3 kg	.59 cu

COM	COL	1	2	3	4	5	6	7	8	9	10	11
1038	1058	1132	1147	1156	1174	1190	1196	1207	1223	1236	1252	1341

sonar 1127/1127B



**Stacking chair
Exposed zebrawood veneer back and seat**

1127 Chrome base
1127B Matte black powder coat base

Stacks six high
When used with stacking cart 1105, Sonar stacks 7 high

Available only in zebrawood finishes. When specifying light finishes the natural characteristics of the wood will be visible and color will vary.

SCS Indoor Advantage™ Gold and LEVEL® 2 certified. See terms and conditions for additional finish and environmental information.

Seat Height	Arm Height	W	D	H	Fabric	Leather	Weight	Cubes/Qty
18"	-	21"	21½"	31½"	-	-	16 lbs	20.99/4
457 mm	-	553 mm	546 mm	800 mm	-	-	7.3 kg	.59 cu

List Price
1236

sonar 1127U/1127UB



**Stacking chair
Exposed zebrawood veneer back
Upholstered seat**

1127U Chrome base
1127UB Matte black powder coat base

Stacks six high
When used with stacking cart 1105, Sonar stacks 7 high

Available only in zebrawood finishes. When specifying light finishes the natural characteristics of the wood will be visible and color will vary.

SCS Indoor Advantage™ Gold and LEVEL® 2 certified. See terms and conditions for additional finish and environmental information.

Seat Height	Arm Height	W	D	H	Fabric	Leather	Weight	Cubes/Qty
18"	-	21"	21½"	31½"	1.0 yds	17.0'	16 lbs	20.99/3
457 mm	-	553 mm	546 mm	800 mm	.92 m	1.6 sqm	7.3 kg	.59 cu

COM	COL	1	2	3	4	5	6	7	8	9	10	11
1141	1161	1235	1250	1259	1277	1293	1299	1310	1326	1339	1355	1444

sonar 1128/1128B



**Stacking chair
Upholstered seat and back**

1128 Chrome base
1128B Matte black powder coat base

Stacks six high
When used with stacking cart 1105, Sonar stacks 7 high

When using a combination of fabrics or leathers, specify the application by designating the appropriate letter, shown below, on the purchase order. Yardage shown must be used.

See terms and conditions for contrasting fabric upcharges.

- A) One fabric or leather for seat
yardage: 1.0 yds. leather: 17.0 sq. ft.
- B) One fabric or leather for seat back
yardage: 1.0 yds. leather: 17.0 sq. ft.

SCS Indoor Advantage™ Gold and LEVEL® 2 certified. See terms and conditions for additional environmental information.

Seat Height	Arm Height	W	D	H	Fabric	Leather	Weight	Cubes/Qty
18"	-	21"	21½"	31½"	2.0 yds	34.0'	16 lbs	20.99/3
457 mm	-	553 mm	546 mm	800 mm	1.9 m	3.2 sqm	7.3 kg	.59 cu

COM	COL	1	2	3	4	5	6	7	8	9	10	11
951	991	1138	1169	1187	1223	1254	1267	1289	1320	1347	1378	1556

velit 1800-40

PLANK



**Stacking chair
Powder coat tubular steel
Indoor and outdoor use**

Stacks four high

Optional removable cushion available. See Velit 1800-99 for more information.

For care and cleaning of outdoor Plank products, see Care and Cleaning - Plank within terms and conditions.

ANSI/BIFMA certified.

Seat Height	Arm Height	W	D	H	Fabric	Leather	Weight	Cubes/Qty
17 3/4"	-	22 7/8"	22"	29 7/8"	-	-	24 lbs.	12.75/1
451 mm	-	581 mm	559 mm	759 mm	-	-	10.9 kg	.36 cu.

List Price
964

sku

frame finish

glides

1	8	0	0	-	4	0
---	---	---	---	---	---	---

01	black	36	moss green
02	white	37	concrete grey
10	oxide red	38	olive green
35	ocean blue		

ST	standard
FT	felt

velit 1800-40-99

PLANK



**Stacking chair
Powder coat tubular steel
Indoor and outdoor use**

Self-skinning integral polyurethane removable cushion

Stacks four high

Cushion matched to powder coat frame finish. White chair standard with grey cushion.

For care and cleaning of outdoor Plank products, see Care and Cleaning - Plank within terms and conditions.

ANSI/BIFMA certified.

Seat Height	Arm Height	W	D	H	Fabric	Leather	Weight	Cubes/Qty
17 3/4"	-	22 7/8"	22"	29 7/8"	-	-	26 lbs.	12.75/1
451 mm	-	581 mm	559 mm	759 mm	-	-	11.8 kg	.36 cu.

List Price
1072

sku

frame finish

glides

1	8	0	0	-	4	0	-	9	9
---	---	---	---	---	---	---	---	---	---

01	black	36	moss green
02	white	37	concrete grey
10	oxide red	38	olive green
35	ocean blue		

ST	standard
TL	teflon

velit 1800-99

PLANK



Cushion

Self-skinning integral polyurethane removable cushion
Optional for Velit 1800-40 chair.

Seat Height	Arm Height	W	D	H	Fabric	Leather	Weight	Cubes/Qty
-	-	-	-	-	-	-	4 lbs.	.25/1
-	-	-	-	-	-	-	1.8 kg	.007 cu.

List Price
109

sku

cushion

1	8	0	0	-	9	9
---	---	---	---	---	---	---

01	black	37	concrete grey
10	oxide red	38	olive green
35	ocean blue	39	light grey
36	moss green		

abra 6180



**Rocking chair
Solid oak base**

Welt standard along perimeter

Inside seat width: 20", Inside seat depth: 20"

Base available in all oak finishes. When specifying light finishes the natural characteristics of the wood will be visible and color will vary.

When using a combination of fabrics or leathers, specify the application by designating the appropriate letter, shown below, on the purchase order. Yardage shown must be used.

See terms and conditions for contrasting upholstery upcharges.

- A) One fabric or leather for seat
yardage: 2.25 yds. leather: 37.0 sq. ft.
- B) One fabric or leather for inside and outside back
yardage: 5.25 yds. leather: 85.0 sq. ft.
- C) One fabric or leather for welt
yardage: 1.0 yds. leather: 16.5 sq. ft.

SCS Indoor Advantage™ Gold certified. See terms and conditions for additional finish and environmental information.

Seat Height	Arm Height	W	D	H	Fabric	Leather	Weight	Cubes/Qty
18¾"	27½"	34½"	37¼"	29¼"	7.5 yds	121.5'	116 lbs	36.08'/1
730 mm	699 mm	867 mm	946 mm	743 mm	.9 m	11.3 sqm	52.6 kg	1.02 cu.

COM	COL	1	2	3	4	5	6	7	8	9	10	11
3500	3650	4200	4317	4384	4517	4634	4684	4767	4884	4984	5100	5767

anne 1890



**Solid walnut frame
Available in natural oiled LV8 finish only
Leather or suede seat with flange stitch**

Not recommended for high-use areas.

SCS Indoor Advantage™ Gold and LEVEL® 2 certified. See terms and conditions for additional finish and environmental information.

Seat Height	Arm Height	W	D	H	Fabric	Leather	Weight	Cubes/Qty
16½"	27¾"	25½"	25"	29½"	-	12.5'	25 lbs	22.25'/1
419 mm	705 mm	651 mm	635 mm	749 mm	-	1.1 sqm	11.4 kg	.63 cu

List Price
5003

astra 4772



**Stationary chair
Fully upholstered**

Chair features welt along the edge
Non-marring glides

When using a combination of fabrics or leathers, specify the application by designating the appropriate letter, shown below, on the purchase order. Yardage shown must be used.

See terms and conditions for contrasting upholstery and welt upcharges.

- A) One fabric or leather for seat
yardage: 1.0 yds. leather: 18.0 sq. ft.
- B) One fabric or leather for chair body
yardage: 5.0 yds. leather: 80.0 sq. ft.
- C) One fabric or leather for welt
yardage: 1.5 yds. leather: 16.0 sq. ft.

SCS Indoor Advantage™ Gold and LEVEL® 2 certified. See terms and conditions for additional environmental information.

Seat Height	Arm Height	W	D	H	Fabric	Leather	Weight	Cubes/Qty
16½"	-	32½"	28¼"	28¾"	5.25 yds	85'	80 lbs	36.09/1
422 mm	-	835 mm	718 mm	730 mm	4.8 m	7.9 sqm	36.4 kg	1.02 cu

COM	COL	1	2	3	4	5	6	7	8	9	10	11
2921	3026	3411	3493	3540	3633	3715	3750	3808	3890	3960	4041	4508

astra 4774



**Self-return swivel
Fully upholstered**

Chair features welt along the top edge

When using a combination of fabrics or leathers, specify the application by designating the appropriate letter, shown below, on the purchase order. Yardage shown must be used.

See terms and conditions for contrasting upholstery and welt upcharges.

- A) One fabric or leather for seat
yardage: 1.0 yds. leather: 18.0 sq. ft.
- B) One fabric or leather for chair body
yardage: 5.0 yds. leather: 80.0 sq. ft.
- C) One fabric or leather for welt
yardage: 1.5 yds. leather: 16.0 sq. ft.

SCS Indoor Advantage™ Gold and LEVEL® 2 certified. See terms and conditions for additional environmental information.

Seat Height	Arm Height	W	D	H	Fabric	Leather	Weight	Cubes/Qty
16½"	-	32½"	28¼"	28¾"	5.25 yds	85'	92 lbs	36.09/1
422 mm	-	835 mm	718 mm	730 mm	4.8 m	7.9 sqm	41.7 kg	1.02 cu

COM	COL	1	2	3	4	5	6	7	8	9	10	11
3268	3373	3758	3840	3887	3980	4062	4097	4155	4237	4307	4388	4855

atlantic 6262

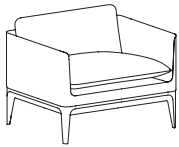

**Solid maple base
Upholstered**

Semi-attached seat and back cushions with a welt perimeter. All other seams are top stitched.

Available in all maple finishes. When specifying light finishes the natural characteristics of the wood will be visible and color will vary.

When using a combination of fabrics or leathers, specify the application by designating the appropriate letter, shown below, on the purchase order. Yardage shown must be used.

See terms and conditions for contrasting upholstery and welt upcharges.

- A) One fabric or leather for inside seat cushion and back
yardage: 4.0 yds. leather: 59.0 sq. ft.
- B) One fabric or leather for outside arms, inside arms
yardage: 3.5 yds. leather: 53.0 sq. ft.

SCS Indoor Advantage™ Gold and LEVEL® 2 certified. See terms and conditions for additional finish and environmental information.

Seat Height	Arm Height	W	D	H	Fabric	Leather	Weight	Cubes/Qty
17½"	24½"	35½"	29¾"	28"	6.5 yds	110.00'	100 lbs.	32.10/1
445 mm	622 mm	902 mm	756 mm	711 mm	5.9 m	10.2 sqm	45.4 kg	.91cu.

COM	COL	1	2	3	4	5	6	7	8	9	10	11
3518	3648	4125	4226	4284	4400	4501	4544	4616	4717	4804	4905	5483

automatic 5730



**Mobile chair with pull strap
Fully upholstered**

Free-wheel swivel casters
Pull strap is pre-sewn and installed during upholstery

Inside seat depth: 22"

When using a combination of fabrics or leathers, specify the application by designating the appropriate letter, shown below, on the purchase order. Yardage shown must be used.

See terms and conditions for contrasting upholstery upcharges.

- A) One fabric or leather for seat and inside back
yardage: 4.0 yds. leather: 65.0 sq. ft.
- B) One fabric or leather for outer shell
yardage: 2.5 yds. leather: 41.0 sq. ft.
- C) One fabric for 1-5 pull straps or one leather for 1-5 pull straps
yardage: 0.5 yds. leather: 10.0 sq.ft

SCS Indoor Advantage™ Gold and Level® 2 certified. See terms and conditions for additional environmental information.

Seat Height	Arm Height	W	D	H	Fabric	Leather	Weight	Cubes/Qty
17¼"	-	31½"	32¾"	30 ½"	6.25 yds.	104.0'	77 lbs.	37.01/1
161 mm	-	800 mm	819 mm	768 mm	5.8 m	9.7 sqm	35 kg	1.05 cu.

COM	COL	1	2	3	4	5	6	7	8	9	10	11
2261	2386	2845	2942	2998	3109	3206	3248	3317	3414	3498	3595	4150

automatic 5730W



**Mobile chair with pull strap
Fully upholstered**

Weight-activated resistant casters for hard floor applications
Pull strap is pre-sewn and installed during upholstery

Inside seat depth: 22"

When using a combination of fabrics or leathers, specify the application by designating the appropriate letter, shown below, on the purchase order. Yardage shown must be used.

See terms and conditions for contrasting upholstery upcharges.

- A) One fabric or leather for seat and inside back
yardage: 4.0 yds. leather: 65.0 sq. ft.
- B) One fabric or leather for outer shell
yardage: 2.5 yds. leather: 41.0 sq. ft.
- C) One fabric for 1-5 pull straps or one leather for 1-5 pull straps
yardage: 0.5 yds. leather: 10.0 sq.ft.

SCS Indoor Advantage™ Gold and Level® 2 certified. See terms and conditions for additional environmental information.

Seat Height	Arm Height	W	D	H	Fabric	Leather	Weight	Cubes/Qty
17¼"	-	31½"	32¾"	30½"	6.25 yds.	104.0'	77 lbs.	37.01'/1
439 mm	-	800 mm	832 mm	775 mm	5.8 m	9.7 sqm	35 kg	1.05 cu.

COM	COL	1	2	3	4	5	6	7	8	9	10	11
2351	2476	2935	3032	3088	3199	3296	3338	3407	3504	3588	3685	4240

automatic 5731



**Stationary chair with pull strap
Fully upholstered**

Non-marring glides
Pull strap is pre-sewn and installed during upholstery

Inside seat depth: 22"

When using a combination of fabrics or leathers, specify the application by designating the appropriate letter, shown below, on the purchase order. Yardage shown must be used.

See terms and conditions for contrasting upholstery upcharges.

- A) One fabric or leather for seat and inside back
yardage: 4.0 yds. leather: 65.0 sq. ft.
- B) One fabric or leather for outer shell
yardage: 2.5 yds. leather: 41.0 sq. ft.
- C) One fabric for 1-5 pull straps or one leather for 1-5 pull straps
yardage: 0.5 yds. leather: 10.0 sq.ft.

SCS Indoor Advantage™ Gold and Level® 2 certified. See terms and conditions for additional environmental information.

Seat Height	Arm Height	W	D	H	Fabric	Leather	Weight	Cubes/Qty
17¼"	-	31½"	32¾"	30½"	6.25 yds.	104.0'	77 lbs.	37.01'/1
439 mm	-	800 mm	832 mm	775 mm	5.8 m	9.7 sqm	35 kg	1.05 cu.

COM	COL	1	2	3	4	5	6	7	8	9	10	11
2261	2386	2845	2942	2998	3109	3206	3248	3317	3414	3498	3595	4150

bardot 4742



Fully upholstered

Standard with welt
Fabric must be non-railroaded

When using a combination of fabrics or leathers, specify the application by designating the appropriate letter, shown below, on the purchase order. Yardage shown must be used.

See terms and conditions for contrasting upholstery and welt upcharges.

- A) One fabric or leather for seat cushion and seat welt, inside back and arms, front panel
yardage: 5.0 yds. leather: 81.0 sq. ft.
- B) One fabric or leather for outer shell and rim
yardage: 6.5 yds. leather: 110.0 sq. ft.
- C) One fabric or leather for inner arm welt
yardage: 0.5 yds. leather: 10.0 sq. ft.

SCS Indoor Advantage™ Gold and LEVEL® 2 certified. See terms and conditions for additional environmental information.

Seat Height	Arm Height	W	D	H	Fabric	Leather	Weight	Cubes/Qty
17"	22½"	32"	34¾"	30"	10.75 yds.	175.0'	90 lbs.	36.09/1
432 mm	575 mm	813 mm	873 mm	762 mm	9.8 m	16.3 sqm	40.8 kg	1.04 cu.

COM	COL	1	2	3	4	5	6	7	8	9	10	11
4716	4931	5720	5887	5983	6174	6341	6413	6532	6699	6843	7010	7965

bardot 4745

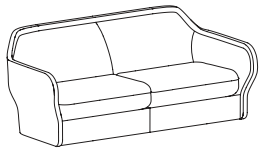

**Two-seat
Fully upholstered**

Standard with welt
Fabric must be non-railroaded

When using a combination of fabrics or leathers, specify the application by designating the appropriate letter, shown below, on the purchase order. Yardage shown must be used.

See terms and conditions for contrasting upholstery and welt upcharges.

- A) One fabric or leather for seat cushion and seat welt, inside back and arms, front panel
yardage: 7.25 yds. leather: 150.0 sq. ft.
- B) One fabric or leather for outer shell and rim
yardage: 8.75 yds. leather: 180.0 sq. ft.
- C) One fabric or leather for inner arm welt
yardage: 0.5 yds. leather: 10.0 sq. ft.

SCS Indoor Advantage™ Gold and LEVEL® 2 certified. See terms and conditions for additional environmental information.

Seat Height	Arm Height	W	D	H	Fabric	Leather	Weight	Cubes/Qty
17"	22½"	75"	34¾"	30"	16.5 yds.	290.0'	180 lbs.	80.67/1
432 mm	575 mm	1905 mm	873 mm	762 mm	15.1 m	81.6 kg	26.9 sqm	2.28 cu.

COM	COL	1	2	3	4	5	6	7	8	9	10	11
7917	8247	9457	9714	9861	10154	10411	10521	10704	10961	11181	11437	12904

bardot 4747

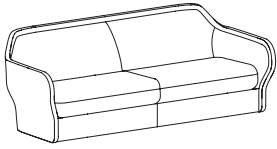

**Three-seat
Fully upholstered**

Standard with welt
Fabric must be non-railroaded

When using a combination of fabrics or leathers, specify the application by designating the appropriate letter, shown below, on the purchase order. Yardage shown must be used.

See terms and conditions for contrasting upholstery and welt upcharges.

- A) One fabric or leather for seat cushion and seat welt, inside back and arms, front panel
yardage: 7.75 yds. leather: 155.0 sq. ft.
- B) One fabric or leather for outer shell and rim
yardage: 9.25 yds. leather: 185.0 sq. ft.
- C) One fabric or leather for inner arm welt
yardage: 0.5 yds. leather: 10.0 sq. ft.

SCS Indoor Advantage™ Gold and LEVEL® 2 certified. See terms and conditions for additional environmental information.

Seat Height	Arm Height	W	D	H	Fabric	Leather	Weight	Cubes/Qty
17"	22½"	87"	34¾"	30"	17.0 yds.	300.0'	210 lbs.	101.65'/1
432 mm	575 mm	2210 mm	873 mm	762 mm	15.5 m	27.9 sqm	95.3 kg	2.88 cu.

COM	COL	1	2	3	4	5	6	7	8	9	10	11
9423	9763	11010	11275	11426	11728	11992	12106	12295	12559	12786	13050	14561

becca 1082



**Fully upholstered
Standard with plain welt
Saddle stitched seams on the inside and outside**

Inside seat width: 21", Inside seat depth: 21"

When using a combination of fabrics or leathers, specify the application by designating the appropriate letter, shown below, on the purchase order. Yardage shown must be used.

See terms and conditions for contrasting upholstery and welt upcharges.

- A) One fabric or leather for inback and seat
yardage: 3.75 yds. leather: 65.0 sq. ft.
- B) One fabric or leather for outback
yardage: 3.75 yds. leather: 65.0 sq. ft.
- C) One fabric or leather for welt
yardage: 1.5 yds. leather: 20.0 sq. ft.

When using decorative trim for welt order:
yardage: 7½ yds. 5mm cord

SCS Indoor Advantage™ Gold and LEVEL® 2 certified. See terms and conditions for additional environmental information.

Seat Height	Arm Height	W	D	H	Fabric	Leather	Weight	Cubes/Qty
17¼"	5¾"	34"	32¼"	31¾"	7.5 yds.	130.0'	91 lbs	36.09'/1
438 mm	137 mm	864 mm	819 mm	797 mm	6.9 m	12.1 sqm	41.3 kg	1.02 cu

COM	COL	1	2	3	4	5	6	7	8	9	10	11
3338	3488	4038	4155	4222	4355	4472	4522	4605	4722	4822	4938	5605

becca 1082L



Available in leather only
Bespoke leather welt
Saddle stitched seams on the inside and outside

Inside seat width: 21", Inside seat depth: 21"

Bespoke Leather Welt Specification: Thread color must be specified. Reference Becca/Stitching on bernhardt.com for color options.

SCS Indoor Advantage™ Gold and LEVEL® 2 certified. See terms and conditions for additional environmental information.

Seat Height	Arm Height	W	D	H	Fabric	Leather	Weight	Cubes/Qty
17¼"	5⅝"	34"	32¼"	31⅝"	-	130.0'	91 lbs	36.09/1
439 mm	138 mm	865 mm	819 mm	797 mm	-	12.1 sqm	41.3 kg	1.02 cu

COL
4738

becca 1085

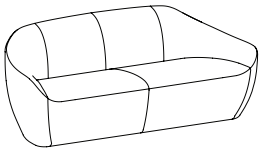

Two-seat
Fully upholstered
Standard with plain welt
Saddle stitched seams on the inside and outside

Inside seat width: 66", Inside seat depth: 22"

When using a combination of fabrics or leathers, specify the application by designating the appropriate letter, shown below, on the purchase order. Yardage shown must be used.

See terms and conditions for contrasting upholstery and welt upcharges.

- A) One fabric or leather for inback and seat
 yardage: 7.5 yds. leather: 140.0 sq. ft.
- B) One fabric or leather for outback
 yardage: 9.0 yds. leather: 165.0 sq. ft.
- C) One fabric or leather for welt
 yardage: 1.5 yds. leather: 20.0 sq. ft.

When using decorative trim for welt order:
 yardage: 15.0 yds. 5mm cord

SCS Indoor Advantage™ Gold and LEVEL® 2 certified. See terms and conditions for additional environmental information.

Seat Height	Arm Height	W	D	H	Fabric	Leather	Weight	Cubes/Qty
18"	6"	84"	31⅝"	31⅝"	16.5 yds.	325.0'	178 lbs.	80.67/1
457 mm	152 mm	2134 mm	810 mm	797 mm	15.1 m	30.2 sqm	80.7 kg	2.3 cu.

COM	COL	1	2	3	4	5	6	7	8	9	10	11
5561	5891	7101	7358	7505	7798	8055	8165	8348	8605	8825	9081	10548

becca 1085L

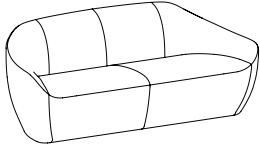

Two-seat
Available in leather only
Bespoke leather welt
Saddle stitched seams on the inside and outside

Inside seat width: 66", Inside seat depth: 22"

Bespoke Leather Welt Specification: Thread color must be specified. Reference Becca/Stitching on bernhardtdesign.com for color options.

SCS Indoor Advantage™ Gold and LEVEL® 2 certified. See terms and conditions for additional environmental information.

Seat Height	Arm Height	W	D	H	Fabric	Leather	Weight	Cubes/Qty
18"	6"	84"	31 $\frac{1}{8}$ "	31 $\frac{1}{8}$ "	-	325.0'	178 lbs.	80.67/1
457 mm	152 mm	2134 mm	810 mm	797 mm	-	30.2 sqm	80.7 kg	2.3 cu.

COL
7141

becca 1087

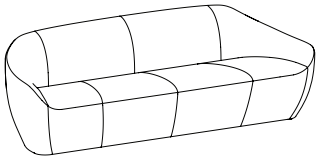

Three-seat
Fully upholstered
Standard with plain welt
Saddle stitched seams on the inside and outside

Inside seat width: 80", Inside seat depth: 22"

When using a combination of fabrics or leathers, specify the application by designating the appropriate letter, shown below, on the purchase order. Yardage shown must be used.

See terms and conditions for contrasting upholstery upcharges.

- A) One fabric or leather for inback and seat
 yardage: 7.5 yds. leather: 140.0 sq. ft.
- B) One fabric or leather for outback
 yardage: 9.0 yds. leather: 165.0 sq. ft.
- C) One fabric or leather for welt
 yardage: 1.5 yds. leather: 20.0 sq. ft.

When using decorative trim for welt order:
 yardage: 15.0 yds. 5mm cord

SCS Indoor Advantage™ Gold and LEVEL® 2 certified. See terms and conditions for additional environmental information.

Seat Height	Arm Height	W	D	H	Fabric	Leather	Weight	Cubes/Qty
18"	6"	98 $\frac{3}{8}$ "	31 $\frac{1}{8}$ "	31 $\frac{1}{8}$ "	16.5 yds.	325.0'	223 lbs.	101.65/1
457 mm	152 mm	2505 mm	810 mm	797 mm	15.1 m	30.2 sqm	101.2 kg	2.88 cu.

COM	COL	1	2	3	4	5	6	7	8	9	10	11
6952	7282	8492	8749	8896	9189	9446	9556	9739	9996	10216	10472	11939

becca 1087L

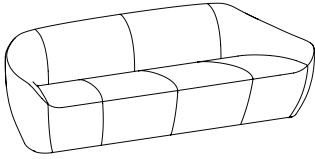

Three-seat
Available in leather only
Bespoke leather welt
Saddle stitched seams on the inside and outside

Inside seat width: 80", Inside seat depth: 22"

Bespoke Leather Welt Specification: Thread color must be specified. Reference Becca/Stitching on bernhardtdesign.com for color options.

SCS Indoor Advantage™ Gold and LEVEL® 2 certified. See terms and conditions for additional environmental information.

Seat Height	Arm Height	W	D	H	Fabric	Leather	Weight	Cubes/Qty
18"	6"	98½"	31½"	31½"	-	325.0'	223 lbs.	101.65'/1
457 mm	152 mm	2505 mm	810 mm	797 mm	-	30.2 sqm	101.2 kg	2.88 cu.

COL
8533

belmont 3401



Solid ash base
Upholstered

Molded foam upper with plywood seat frame

Inside seat width: 23½" (taken at the middle of the arms), Inside seat depth: 21½"

Available in all ash finishes. When specifying light finishes the natural characteristics of the wood will be visible and color will vary.

When using a combination of fabrics or leathers, specify the application by designating the appropriate letter, shown below, on the purchase order. Yardage shown must be used.

See terms and conditions for contrasting fabric upcharges.

- A) One fabric or leather for seat
 yardage: 1.5 yds leather: 24 sq. ft.
- B) One fabric or leather for inside and outside back, sides, inside arms and front panel
 yardage: 5.75 yds. leather: 95 sq. ft.

SCS Indoor Advantage™ Gold and LEVEL® 2 certified. See terms and conditions for additional finish and environmental information.

Seat Height	Arm Height	W	D	H	Fabric	Leather	Weight	Cubes/Qty
18"	24½"	34½"	35¼"	42¼"	7.1 yds.	115.0'	106 lbs.	44.01'/1
458 mm	623 mm	877 mm	908 mm	1080 mm	5.6 m	9.2 sqm	48.1 kg	1.25 cu.

COM	COL	1	2	3	4	5	6	7	8	9	10	11
4374	4516	5037	5148	5211	5337	5447	5495	5574	5684	5779	5889	6520

belmont 3402



**Polished stainless steel or powder coat base
Upholstered**

Molded foam upper with plywood seat frame.

Inside seat width: 23½" (taken at the middle of the arms), Inside seat depth: 21⅝"

When using a combination of fabrics or leathers, specify the application by designating the appropriate letter, shown below, on the purchase order. Yardage shown must be used.

See terms and conditions for contrasting fabric upcharges.

- A) One fabric or leather for seat
yardage: 1.5 yds. leather: 24 sq. ft.
- B) One fabric or leather for inside and outside back, sides, inside arms and front panel
yardage: 5.75 yds. leather: 95 sq. ft.

SCS Indoor Advantage™ Gold and LEVEL® 2 certified. See terms and conditions for additional finish and environmental information.

Seat Height	Arm Height	W	D	H	Fabric	Leather	Weight	Cubes/Qty
18"	24½"	34½"	35¾"	42¼"	7.1 yds.	115.0'	115 lbs.	44.01'/1
458 mm	623 mm	877 mm	908 mm	1080 mm	5.6 m	9.2 sqm	52.2 kg	1.25 cu.

COM	COL	1	2	3	4	5	6	7	8	9	10	11
3998	4140	4661	4772	4835	4961	5071	5119	5198	5308	5403	5513	6144

sku

3	4	0	2									

base finish

polished stainless steel standard, OR

specify powder coat, upcharge \$150

WH satin white	GR graphite	RD black red
EC ecru	BZ bronze	BK matte black
LA latte	IG iron grey	

blaine 6458



**Low back
Solid maple base
Upholstered**

Welt standard along bottom edge

Available in all maple finishes. When specifying light finishes the natural characteristics of the wood will be visible and color will vary.

When using a combination of fabrics or leathers, specify the application by designating the appropriate letter, shown below, on the purchase order. Yardage shown must be used.

See terms and conditions for contrasting upholstery and welt upcharges.

- A) One fabric or leather for seat, inside back and front panel below seat cushion
yardage: 2.75 yds. leather: 52.0 sq. ft.
- B) One fabric or leather for outside back and sides, inside arms, welt
yardage: 4.0 yds. leather: 68.0 sq. ft.

SCS Indoor Advantage™ Gold and LEVEL® 2 certified. See terms and conditions for additional finish and environmental information.

Seat Height	Arm Height	W	D	H	Fabric	Leather	Weight	Cubes/Qty
17¾"	22½"	29½"	31"	33"	6.8 yds.	120.0'	87 lbs.	36.09/1
451 mm	572 mm	749 mm	787 mm	838 mm	6.2 m	11.1 sqm	39.5 kg	1.04 cu.

COM	COL	1	2	3	4	5	6	7	8	9	10	11
2930	3066	3565	3671	3731	3852	3958	4003	4079	4185	4275	4381	4986

blaine 6465

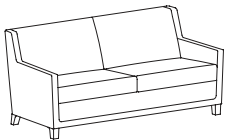

**Two-seat
Low back
Solid maple base
Upholstered**

Welt standard along bottom edge of chair

Available in all maple finishes. When specifying light finishes the natural characteristics of the wood will be visible and color will vary.

When using a combination of fabrics or leathers, specify the application by designating the appropriate letter, shown below, on the purchase order. Yardage shown must be used.

See terms and conditions for contrasting upholstery and welt upcharges.

- A) One fabric or leather for seat, inside back and front panel below seat cushion
yardage: 5.5 yds. leather: 100.0 sq. ft.
- B) One fabric or leather for outside back and sides, inside arms, welt
yardage: 6.5 yds. leather: 120.0 sq. ft.

SCS Indoor Advantage™ Gold and LEVEL® 2 certified. See terms and conditions for additional finish and environmental information.

Seat Height	Arm Height	W	D	H	Fabric	Leather	Weight	Cubes/Qty
17¾"	22½"	72"	31"	33"	11.25 yds.	200.0'	147.0 lbs.	100.22/1
451 mm	572 mm	1829 mm	787 mm	838 mm	10.3 m	18.6 sqm	66.7 kg	2.84 cu.

COM	COL	1	2	3	4	5	6	7	8	9	10	11
4444	4669	5494	5669	5769	5969	6144	6219	6344	6519	6669	6844	7844

blaine.02 6459



**High back
Solid maple base
Upholstered**

Welt standard along bottom edge of chair
High back with 8" x 23"w pillow secured with two snaps, non-reversible.

Available in all maple finishes. When specifying light finishes the natural characteristics of the wood will be visible and color will vary.

When using a combination of fabrics or leathers, specify the application by designating the appropriate letter, shown below, on the purchase order. Yardage shown must be used.

See terms and conditions for contrasting upholstery and welt upcharges.

- A) One fabric or leather for seat, inside back and front panel below seat cushion
yardage: 2.5 yds. leather: 37.0 sq. ft.
- B) One fabric or leather for outside back and sides, inside arms, welt
yardage: 5.4 yds. leather: 72.9 sq. ft.
- C) One fabric or leather for pillow
yardage: 1.0 yd. leather: 13.5 sq. ft.

SCS Indoor Advantage™ Gold and LEVEL® 2 certified. See terms and conditions for additional finish and environmental information.

Seat Height	Arm Height	W	D	H	Fabric	Leather	Weight	Cubes/Qty
17¾"	22½"	29½"	35¼"	41½"	7.65 yds.	140.0'	90 lbs.	42.88'/1
451 mm	572 mm	749 mm	895 mm	1054 mm	7.0 m	13.0 sqm	40.8 kg	1.21 cu.

COM	COL	1	2	3	4	5	6	7	8	9	10	11
4155	4308	4869	4988	5056	5192	5311	5362	5447	5566	5668	5787	6467

blaine.02 6460



**High back
Solid maple base
Upholstered**

Welt standard on bottom edge of chair

Available in all maple finishes. When specifying light finishes the natural characteristics of the wood will be visible and color will vary.

When using a combination of fabrics or leathers, specify the application by designating the appropriate letter, shown below, on the purchase order. Yardage shown must be used.

See terms and conditions for contrasting upholstery and welt upcharges.

- A) One fabric or leather for seat, inside back and front panel below seat cushion
yardage: 2.5 yds. leather: 37.0 sq. ft.
- B) One fabric or leather for outside back and sides, inside arms, welt
yardage: 5.4 yds. leather: 72.9 sq. ft.

SCS Indoor Advantage™ Gold and LEVEL® 2 certified. See terms and conditions for additional finish and environmental information.

Seat Height	Arm Height	W	D	H	Fabric	Leather	Weight	Cubes/Qty
17¾"	22½"	29½"	35¼"	41½"	7.25 yds.	140.0'	90 lbs.	42.88'/1
451 mm	572 mm	749 mm	895 mm	1054 mm	6.6 m	13.0 sqm	40.8 kg	1.21 cu.

COM	COL	1	2	3	4	5	6	7	8	9	10	11
3872	4017	4549	4662	4726	4855	4968	5016	5097	5210	5306	5419	6064

bombom 1076



**Self-return swivel
Polished stainless steel base
Upholstered**

Sewn in welt

When using a combination of fabrics or leathers, specify the application by designating the appropriate letter, shown below, on the purchase order. Yardage shown must be used.

See terms and conditions for contrasting upholstery upcharges.

- A) One fabric for seat and back cushion
yardage: 2.25 yds.
- B) One fabric or leather for outside shell
yardage: 2.25 yds. leather: 36.5 sq. ft.

Certain horizontal stripes, plaids or fabrics with little stretch are not suitable for this product.

SCS Indoor Advantage™ Gold and LEVEL® 2 certified. See terms and conditions for additional environmental information.

Seat Height	Arm Height	W	D	H	Fabric	Leather	Weight	Cubes/Qty
19¼"	30"	34¼"	30¼"	30"	4.5 yds	-	79 lbs	35.18'/1
489 mm	762 mm	870 mm	768 mm	762 mm	4.15 m	-	35.8 kg	.97 cu

COM	COL	1	2	3	4	5	6	7	8	9	10	11
3547	3637	3967	4037	4077	4157	4227	4257	4307	4377	4437	4507	4907

bombom 1076K



**Self-return swivel
Matte black powder coat base
Upholstered**

Sewn in welt

When using a combination of fabrics or leathers, specify the application by designating the appropriate letter, shown below, on the purchase order. Yardage shown must be used.

See terms and conditions for contrasting upholstery upcharges.

- A) One fabric for seat and back cushion
yardage: 2.25 yds.
- B) One fabric or leather for outside shell
yardage: 2.25 yds. leather: 36.5 sq. ft.

Certain horizontal stripes, plaids or fabrics with little stretch are not suitable for this product.

SCS Indoor Advantage™ Gold and LEVEL® 2 certified. See terms and conditions for additional environmental information.

Seat Height	Arm Height	W	D	H	Fabric	Leather	Weight	Cubes/Qty
19¼"	30"	34¼"	30¼"	30"	4.5 yds	-	79 lbs	35.18'/1
489 mm	762 mm	870 mm	768 mm	762 mm	4.15 m	-	35.8 kg	.97 cu

COM	COL	1	2	3	4	5	6	7	8	9	10	11
3721	3811	4141	4211	4251	4331	4401	4431	4481	4551	4611	4681	5081

canelle 4756



**Self-return swivel
Polished aluminum or powder coat base
Upholstered**

When using a combination of fabrics or leathers, specify the application by designating the appropriate letter, shown below, on the purchase order. Yardage shown must be used.

See terms and conditions for contrasting upholstery upcharges.

- A) One fabric or leather for seat
yardage: 1.0 yds. leather: 15.0 sq. ft.
- B) One fabric or leather for inside and outside back, sides and inside arms
yardage: 2.75 yds. leather: 45.0 sq. ft

SCS Indoor Advantage™ Gold and LEVEL® 2 certified. See terms and conditions for additional finish and environmental information.

Seat Height	Arm Height	W	D	H	Fabric	Leather	Weight	Cubes/Qty
17"	24"	31"	34"	39½"	3.5 yds.	47.5'	72 lbs.	40.56'/1
432 mm	610 mm	787 mm	864 mm	1000 mm	3.2 m	4.4 sqm	32.7 kg	1.15 cu.

COM	COL	1	2	3	4	5	6	7	8	9	10	11
3128	3198	3455	3510	3541	3603	3657	3681	3720	3774	3821	3875	4186

sku

4	7	5	6									

powder coat finish

polished aluminum standard, OR

specify powder coat, upcharge \$150

WH satin white	IG iron grey
GR graphite	RD black red
BZ bronze	K matte black

--	--	--	--	--	--	--	--	--	--	--	--	--

canelle 4756P



**Self-return swivel
Polished aluminum or powder coat base
Upholstered
Pillow with topstitch**

When using a combination of fabrics or leathers, specify the application by designating the appropriate letter, shown below, on the purchase order. Yardage shown must be used.

See terms and conditions for contrasting upholstery upcharges.

- A) One fabric or leather for seat
yardage: 1.0 yds. leather: 15.0 sq. ft.
- B) One fabric or leather for inside and outside back, sides and inside arms
yardage: 2.75 yds. leather: 45.0 sq. ft

SCS Indoor Advantage™ Gold and LEVEL® 2 certified. See terms and conditions for additional finish and environmental information.

Seat Height	Arm Height	W	D	H	Fabric	Leather	Weight	Cubes/Qty
17"	24"	31"	34"	39%"	3.5 yds.	47.5'	72 lbs.	40.56'/1
432 mm	610 mm	787 mm	864 mm	1000 mm	3.2 m	4.4 sqm	32.7 kg	1.15 cu.

COM	COL	1	2	3	4	5	6	7	8	9	10	11
3128	3198	3455	3510	3541	3603	3657	3681	3720	3774	3821	3875	4186

sku

4	7	5	6	P								

powder coat finish

polished aluminum standard, OR

specify powder coat, upcharge \$150

WH satin white	IG iron grey
GR graphite	RD black red
BZ bronze	K matte black

canelle 4757M



**Solid maple base
Upholstered**

Available in all maple finishes. When specifying light finishes the natural characteristics of the wood will be visible and color will vary.

When using a combination of fabrics or leathers, specify the application by designating the appropriate letter, shown below, on the purchase order. Yardage shown must be used.

See terms and conditions for contrasting upholstery upcharges.

- A) One fabric or leather for seat
yardage: 1.0 yds. leather: 15.0 sq. ft.
- B) One fabric or leather for inside and outside back, sides and inside arms
yardage: 2.75 yds. leather: 45.0 sq. ft.

SCS Indoor Advantage™ Gold and LEVEL® 2 certified. See terms and conditions for additional finish and environmental information.

Seat Height	Arm Height	W	D	H	Fabric	Leather	Weight	Cubes/Qty
17"	24"	31"	34"	41"	3.5 yds.	47.5'	49 lbs.	40.56'/1
432 mm	610 mm	787 mm	864 mm	1041 mm	3.2 m	4.4 sqm	22.2 kg	1.15 cu.

COM	COL	1	2	3	4	5	6	7	8	9	10	11
3466	3536	3793	3848	3879	3941	3995	4019	4058	4112	4159	4213	4524

canelle 4757PM



**Solid maple base
Upholstered
Pillow with topstitch**

Available in all maple finishes. When specifying light finishes the natural characteristics of the wood will be visible and color will vary.

When using a combination of fabrics or leathers, specify the application by designating the appropriate letter, shown below, on the purchase order. Yardage shown must be used.

See terms and conditions for contrasting upholstery upcharges.

- A) One fabric or leather for seat
yardage: 1.0 yds. leather: 15.0 sq. ft.
- B) One fabric or leather for inside and outside back, sides and inside arms
yardage: 2.7 yds. leather: 45.0 sq. ft.

SCS Indoor Advantage™ Gold and LEVEL® 2 certified. See terms and conditions for additional finish and environmental information.

Seat Height	Arm Height	W	D	H	Fabric	Leather	Weight	Cubes/Qty
17"	24"	31"	34"	41"	3.5 yds.	47.5'	49 lbs.	40.56'/1
432 mm	610 mm	787 mm	864 mm	1041 mm	3.2 m	4.4 sqm	22.2 kg	1.15 cu.

COM	COL	1	2	3	4	5	6	7	8	9	10	11
3466	3536	3793	3848	3879	3941	3995	4019	4058	4112	4159	4213	4524

canelle 4757W



**Solid walnut base
Upholstered**

Available in all walnut finishes. When specifying light finishes the natural characteristics of the wood will be visible and color will vary.

When using a combination of fabrics or leathers, specify the application by designating the appropriate letter, shown below, on the purchase order. Yardage shown must be used.

See terms and conditions for contrasting upholstery upcharges.

- A) One fabric or leather for seat
yardage: 1.0 yds. leather: 15.0 sq. ft.
- B) One fabric or leather for inside and outside back, sides and inside arms
yardage: 2.75 yds. leather: 45.0 sq. ft.

SCS Indoor Advantage™ Gold and LEVEL® 2 certified. See terms and conditions for additional finish and environmental information.

Seat Height	Arm Height	W	D	H	Fabric	Leather	Weight	Cubes/Qty
17"	24"	31"	34"	41"	3.5 yds.	47.5'	49 lbs.	40.56'/1
432 mm	610 mm	787 mm	864 mm	1041 mm	3.2 m	4.4 sqm	22.2 kg	1.15 cu.

COM	COL	1	2	3	4	5	6	7	8	9	10	11
3611	3681	3938	3993	4024	4086	4140	4164	4203	4257	4304	4358	4669

canelle 4757PW



**Solid walnut base
Upholstered
Pillow with topstitch**

Available in all walnut finishes. When specifying light finishes the natural characteristics of the wood will be visible and color will vary.

When using a combination of fabrics or leathers, specify the application by designating the appropriate letter, shown below, on the purchase order. Yardage shown must be used.

See terms and conditions for contrasting upholstery upcharges.

- A) One fabric or leather for seat
yardage: 1.0 yds. leather: 15.0 sq. ft.
- B) One fabric or leather for inside and outside back, sides and inside arms
yardage: 2.75 yds. leather: 45.0 sq. ft.

SCS Indoor Advantage™ Gold and LEVEL® 2 certified. See terms and conditions for additional finish and environmental information.

Seat Height	Arm Height	W	D	H	Fabric	Leather	Weight	Cubes/Qty
17"	24"	31"	34"	41"	3.5 yds.	47.5'	49 lbs.	40.56'/1
432 mm	610 mm	787 mm	864 mm	1041 mm	3.2 m	4.4 sqm	22.2 kg	1.15 cu.

COM	COL	1	2	3	4	5	6	7	8	9	10	11
3611	3681	3938	3993	4024	4086	4140	4164	4203	4257	4304	4358	4669

cantata 1202



Solid oak

Available in all oak finishes. When specifying light finishes the natural characteristics of the wood will be visible and color will vary.

SCS Indoor Advantage™ Gold and LEVEL® 2 certified. See terms and conditions for additional finish and environmental information.

Seat Height	Arm Height	W	D	H	Fabric	Leather	Weight	Cubes/Qty
15 ⁷ / ₈ "	25"	24 ¹ / ₂ "	22 ⁷ / ₈ "	27 ⁷ / ₈ "	-	-	28 lbs	21.35'/1
384 mm	635 mm	623 mm	583 mm	708 mm	-	-	12.7 kg	.6 cu

List Price
1317

cantata 1203



**Solid oak
Upholstered seat cushion**

Available in all oak finishes. When specifying light finishes the natural characteristics of the wood will be visible and color will vary.

SCS Indoor Advantage™ Gold and LEVEL® 2 certified. See terms and conditions for additional finish and environmental information.

Seat Height	Arm Height	W	D	H	Fabric	Leather	Weight	Cubes/Qty
15 ⁷ / ₈ "	25"	24 ¹ / ₂ "	22 ⁷ / ₈ "	27 ⁷ / ₈ "	1 yd.	18.0'	28 lbs	21.35'/1
404 mm	635 mm	623 mm	583 mm	708 mm	.92 m	1.7 sqm	12.7 kg	.6 cu

COM	COL	1	2	3	4	5	6	7	8	9	10	11
1419	1439	1513	1528	1537	1555	1571	1577	1588	1604	1617	1633	1722

casino modular lounge

4971 - 4982 Casino Modular Lounge

Casino: a modular seating product comprised of 13 unique modules which may be used interchangeably to create an unlimited number of configurations.

For complete information reference Casino in the lounge/modular section of the price list.

catherine 4750

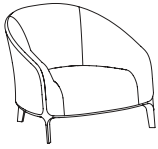

**Solid maple base
Upholstered**

Exposed wood trim
Welt around perimeter of the wood trim
Height of arm: 21" at center

Available in all maple finishes. When specifying light finishes the natural characteristics of the wood will be visible and color will vary.

When using a combination of fabrics or leathers, specify the application by designating the appropriate letter, shown below, on the purchase order. Yardage shown must be used.

See terms and conditions for contrasting upholstery and welt upcharges.

- A) One fabric or leather for inside seat, inside back, inside arms and inside welt
yardage: 3.0 yds. leather: 50.0 sq. ft.
- B) One fabric or leather for outside and outside welt
yardage: 2.5 yds. leather: 40.5 sq. ft

SCS Indoor Advantage™ Gold and LEVEL® 2 certified. See terms and conditions for additional finish and environmental information.

Seat Height	Arm Height	W	D	H	Fabric	Leather	Weight	Cubes/Qty
15¼"	21"	34⅞"	32¾"	29¼"	5.0 yds.	75.0'	60 lbs.	36.09'/1
387 mm	533 mm	886 mm	832 mm	743 mm	4.6 m	7.0 sqm	27.2 kg	1.04 cu.

COM	COL	1	2	3	4	5	6	7	8	9	10	11
3735	3835	4202	4280	4324	4413	4491	4524	4580	4658	4724	4802	5247

chapelle 4874/4874B

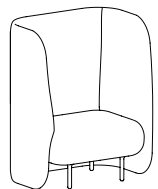

**One-seat with attached privacy wall
Full wall
Upholstered**

- 4874 Polished aluminum legs**
- 4874B Matte black powder coat legs**

Shipped assembled
Standard with welt around seat

Inside seat width: 25", Inside seat depth: 22⅞"

When using a combination of fabrics, specify the application by designating the appropriate letter, shown below, on the purchase order. Yardage shown must be used.

See terms and conditions for contrasting upholstery and welt upcharges.

- A) One fabric for seat
yardage: 2.9 yds.
- B) One fabric for wall
yardage: 7.4 yds.
- C) One fabric for contrast welt
yardage: 0.5 yds.

SCS Indoor Advantage™ Gold and LEVEL® 2 certified. See terms and conditions for additional environmental information.

Seat Height	Arm Height	W	D	H	Fabric	Leather	Weight	Cubes/Qty
18"	-	38"	28⅞"	47⅞"	11.2 yds.	-	161.5 lbs	45.12'/1
457 mm	-	965 mm	714 mm	1203 mm	10.3 m	-	73.3 kg	1.3 cu.

COM	COL	1	2	3	4	5	6	7	8	9	10	11
4449	0	5495	5669	5769	5968	6142	6217	6341	6515	6665	6839	7834

chapelle 4875/4875B

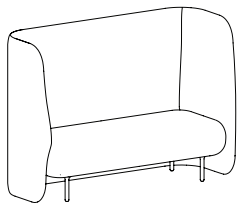

Two-seat with attached privacy wall
Full wall
Upholstered
4875 Polished aluminum legs
4875B Matte black powder coat legs
 Shipped assembled
 Standard with welt around seat

Inside seat width: 57¼", Inside seat depth: 22⅞"

When using a combination of fabrics, specify the application by designating the appropriate letter, shown below, on the purchase order. Yardage shown must be used.

See terms and conditions for contrasting upholstery and welt upcharges.

- A) One fabric for seat
yardage: 5.5 yds.
- B) One fabric for wall
yardage: 9.0 yds.
- C) One fabric for contrast welt
yardage: 0.5 yds.

SCS Indoor Advantage™ Gold and LEVEL® 2 certified. See terms and conditions for additional environmental information.

Seat Height	Arm Height	W	D	H	Fabric	Leather	Weight	Cubes/Qty
18"	-	68½"	28⅞"	47⅞"	14.5 yds.	-	205 lbs.	95.46/1
457 mm	-	1740 mm	714 mm	1203 mm	13.3 m	-	92.9 kg	2.7 cu.

COM	COL	1	2	3	4	5	6	7	8	9	10	11
6115	0	7469	7694	7823	8081	8307	8403	8564	8790	8983	9209	10498

chapelle 4877/4877B

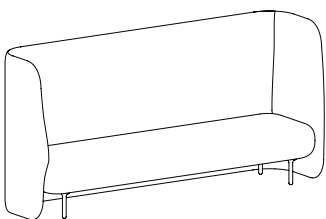

Three-seat with attached privacy wall
Full wall
Upholstered
4877 Polished aluminum legs
4877B Matte black powder coat legs

Shipped assembled
 Standard with welt around seat

Inside seat width: 87", Inside seat depth: 22⅞"

When using a combination of fabrics, specify the application by designating the appropriate letter, shown below, on the purchase order. Yardage shown must be used.

See terms and conditions for contrasting upholstery and welt upcharges.

- A) One fabric for seat
yardage: 7.0 yds.
- B) One fabric for wall
yardage: 11.5 yds.
- C) One fabric for contrast welt
yardage: 0.5 yds.

SCS Indoor Advantage™ Gold and LEVEL® 2 certified. See terms and conditions for additional environmental information.

Seat Height	Arm Height	W	D	H	Fabric	Leather	Weight	Cubes/Qty
18"	-	99¾"	28⅞"	47⅞"	18.5 yds.	-	265 lbs.	134.13/1
457 mm	-	2534 mm	714 mm	1203 mm	16.9 m	-	120.2 kg	3.8 cu.

COM	COL	1	2	3	4	5	6	7	8	9	10	11
8208	0	9935	10223	10387	10716	11004	11127	11333	11621	11867	12155	13800

chapelle 4885

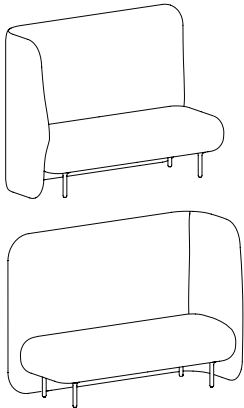

Two-seat with attached privacy wall
Open end
Polished aluminum or powder coat legs
Upholstered

Shipped assembled
 Standard with welt around seat.

Inside seat width: 60", Inside seat depth: 22 1/8"

When using a combination of fabrics, specify the application by designating the appropriate letter, shown below, on the purchase order. Yardage shown must be used.

See terms and conditions for contrasting upholstery and welt upcharges.

- A) One fabric for seat
yardage: 5.5 yds.
- B) One fabric for wall
yardage: 9.0 yds.
- C) One fabric for contrast welt
yardage: 0.5 yds.

SCS Indoor Advantage™ Gold and LEVEL® 2 certified. See terms and conditions for additional environmental information.

Seat Height	Arm Height	W	D	H	Fabric	Leather	Weight	Cubes/Qty
18"	-	65 3/4"	28 1/8"	47 3/8"	14.5 yds.	-	200 lbs.	91.83/1
457 mm		1670mm	714 mm	1203 mm	13.3 m	-	99.8 kg	2.6 cu.

COM	COL	1	2	3	4	5	6	7	8	9	10	11
5634	0	6988	7213	7342	7600	7826	7922	8083	8309	8502	8728	10017

sku

4	8	8	5	

leg finish

L	left wall facing, polished aluminum legs		
LB	left wall facing, matte black powder coat legs		
R	right wall facing, polished aluminum legs		
RB	right wall facing, matte black powder coat legs		

chapelle 4887

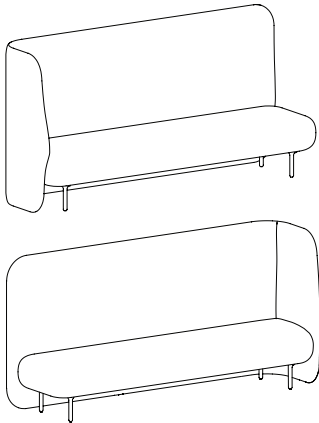

Three-seat with attached privacy wall
Open End
Polished aluminum or powder coat legs
Upholstered

Shipped assembled
 Standard with welt around seat

Inside seat width: 92", Inside seat depth: 22 7/8"

When using a combination of fabrics, specify the application by designating the appropriate letter, shown below, on the purchase order. Yardage shown must be used.

See terms and conditions for contrasting upholstery and welt upcharges.

- A) One fabric for seat
yardage: 7.0 yds.
- B) One fabric for wall
yardage: 10.0 yds.
- C) One fabric for contrast welt
yardage: 0.5 yds.

SCS Indoor Advantage™ Gold and LEVEL® 2 certified. See terms and conditions for additional environmental information.

Seat Height	Arm Height	W	D	H	Fabric	Leather	Weight	Cubes/Qty
18"	-	97 1/2"	28 1/6"	47 3/4"	17.0 yds.	-	255 lbs.	130.5/1
457 mm	-	2477 mm	714 mm	1203 mm	15.5 m	-	115.7 kg	3.7 cu.

COM	COL	1	2	3	4	5	6	7	8	9	10	11
7725	0	9312	9577	9728	10030	10294	10408	10597	10861	11088	11352	12863

sku

4	8	8	7									

leg finish

L	left wall facing, polished aluminum legs											
LB	left wall facing, matte black powder coat legs											
R	right wall facing, polished aluminum legs											
RB	right wall facing, matte black powder coat legs											

chapelle 4895

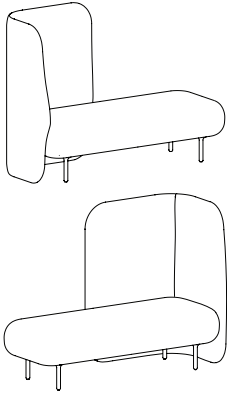

Two-seat with attached privacy wall
Half wall
Polished aluminum or powder coat legs
Upholstered

Shipped assembled
 Standard with welt around seat

Inside seat width: 60", Inside seat depth: 22 7/8"

When using a combination of fabrics, specify the application by designating the appropriate letter, shown below, on the purchase order. Yardage shown must be used.

See terms and conditions for contrasting upholstery and welt upcharges.

- A) One fabric for seat
yardage: 5.5 yds.
- B) One fabric for wall
yardage: 5.0 yds.
- C) One fabric for contrast welt
yardage: 0.5 yds.

SCS Indoor Advantage™ Gold and LEVEL® 2 certified. See terms and conditions for additional environmental information.

Seat Height	Arm Height	W	D	H	Fabric	Leather	Weight	Cubes/Qty
18"	-	65 1/2"	28 1/8"	47 3/4"	10.5 yds.	-	220 lbs.	91.83/1
457 mm	-	1664 mm	714 mm	1203 mm	9.6 m	-	99.8 kg	2.6 cu.

COM	COL	1	2	3	4	5	6	7	8	9	10	11
5152	0	6132	6296	6389	6576	6739	6809	6926	7089	7229	7392	8326

sku

4	8	9	5									

leg finish

L	left wall facing, polished aluminum legs											
LB	left wall facing, matte black powder coat legs											
R	right wall facing, polished aluminum legs											
RB	right wall facing, matte black powder coat legs											

chapelle 4897

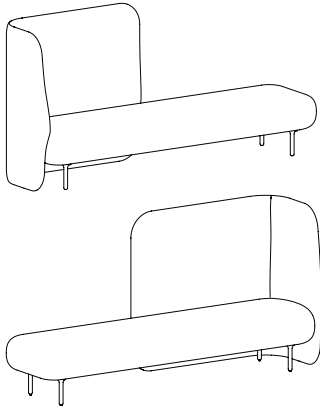

Three-seat with attached privacy wall
Half wall
Polished aluminum or powder coat legs
Upholstered

Shipped assembled
 Standard with welt around seat

Inside seat width: 92", Inside seat depth: 22 1/8"

When using a combination of fabrics, specify the application by designating the appropriate letter, shown below, on the purchase order. Yardage shown must be used.

See terms and conditions for contrasting upholstery and welt upcharges.

- A) One fabric for seat
yardage: 7.0 yds.
- B) One fabric for wall
yardage: 7.0 yds.
- C) One fabric for contrast welt
yardage: 0.5 yds.

SCS Indoor Advantage™ Gold and LEVEL® 2 certified. See terms and conditions for additional environmental information.

Seat Height	Arm Height	W	D	H	Fabric	Leather	Weight	Cubes/Qty
18"	-	97 1/4"	28 1/8"	47 3/8"	14.0 yds.	-	220 lbs.	130.5/1
457 mm	-	2470 mm	714 mm	1203 mm	12.8 m	-	99.8 kg	3.7 cu.

COM	COL	1	2	3	4	5	6	7	8	9	10	11
7242	0	8549	8767	8891	9140	9358	9451	9607	9825	10011	10229	11474

sku

4	8	9	7									

leg finish

L												
LB												
R												
RB												

chiara 4755



**Self-return swivel
Polished aluminum or powder coat base
Upholstered**

When using a combination of fabrics or leathers, specify the application by designating the appropriate letter, shown below, on the purchase order. Yardage shown must be used.

See terms and conditions for contrasting upholstery upcharges.

- A) One fabric or leather for seat
yardage: 1.0 yds. leather: 13.7 sq. ft.
- B) One fabric or leather for inside and outside shell
yardage: 3.2 yds. leather: 43.3 sq. ft.

Certain horizontal stripes, plaids or fabrics with little stretch are not suitable for this product.

SCS Indoor Advantage™ Gold and LEVEL® 2 certified. See terms and conditions for additional finish and environmental information.

Seat Height	Arm Height	W	D	H	Fabric	Leather	Weight	Cubes/Qty
16½"	-	33"	29"	29"	4.2 yds.	57.0'	54 lbs.	34.26/1
419 mm	-	838 mm	737 mm	737 mm	3.8 m	5.3 sqm	24.5 kg	.97 cu.

COM	COL	1	2	3	4	5	6	7	8	9	10	11
2493	2577	2885	2951	2988	3063	3128	3156	3203	3268	3324	3389	3763

sku

4	7	5	5										

powder coat finish

polished aluminum standard, OR

specify powder coat, upcharge \$150

- | | |
|-----------------------|----------------------|
| WH satin white | IG iron grey |
| GR graphite | RD black red |
| BZ bronze | K matte black |

--	--

chiara 4755W



**Solid walnut base
Upholstered**

Available in all walnut finishes. When specifying light finishes the natural characteristics of the wood will be visible and color will vary.

When using a combination of fabrics or leathers, specify the application by designating the appropriate letter, shown below, on the purchase order. Yardage shown must be used.

See terms and conditions for contrasting upholstery upcharges.

- A) One fabric or leather for seat
yardage: 1.0 yds. leather: 13.7 sq. ft.
- B) One fabric or leather for inside and outside shell
yardage: 3.2 yds. leather: 43.3 sq. ft.

Certain horizontal stripes, plaids or fabrics with little stretch are not suitable for this product.

SCS Indoor Advantage™ Gold and LEVEL® 2 certified. See terms and conditions for additional finish and environmental information.

Seat Height	Arm Height	W	D	H	Fabric	Leather	Weight	Cubes/Qty
16½"	-	33"	29"	29½"	4.2 yds.	57.0'	54 lbs.	34.26/1
419 mm	-	838 mm	737 mm	737 mm	3.8 m	5.3 sqm	24.5 kg	.97 cu.

COM	COL	1	2	3	4	5	6	7	8	9	10	11
2970	3054	3362	3428	3465	3540	3605	3633	3680	3745	3801	3866	4240

cinema 4800

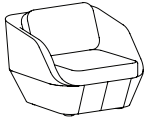

Fully upholstered

When using a combination of fabrics or leathers, specify the application by designating the appropriate letter, shown below, on the purchase order. Yardage shown must be used.

See terms and conditions for contrasting upholstery upcharges.

- A) One fabric or leather for seat and inside back
yardage: 3.0 yds. leather: 50.0
- B) One fabric or leather for inside and outside shell
yardage: 4.5 yds. leather: 75.0 sq. ft.

SCS Indoor Advantage™ Gold and LEVEL® 2 certified. See terms and conditions for additional environmental information.

Seat Height	Arm Height	W	D	H	Fabric	Leather	Weight	Cubes/Qty
17½"	23¼"	32½"	36"	29½"	6.5 yds.	125.0'	64 lbs.	36.09/1
445 mm	591 mm	826 mm	914 mm	749 mm	5.9 m	11.6sqm	29.1 kg	1.04 cu.

COM	COL	1	2	3	4	5	6	7	8	9	10	11
2670	2800	3277	3378	3436	3552	3653	3696	3768	3869	3956	4057	4635

cinema modular lounge

4818 - 4826 Cinema Modular Lounge

Cinema has modular seating comprised of 15 unique modules which may be used interchangeably to create an unlimited number of configurations.

For complete information, reference Cinema in the lounge - modular section of the price list.

claire 4799



**Solid walnut frame
Upholstered**

Available in all walnut finishes. When specifying light finishes the natural characteristics of the wood will be visible and color will vary. See terms and conditions.

SCS Indoor Advantage™ Gold and Level® 2 certified. See terms and conditions for additional environmental information.

Seat Height	Arm Height	W	D	H	Fabric	Leather	Weight	Cubes/Qty
17¾"	-	27¼"	34⅝"	31"	4.0 yds.	50.0'	65 lbs.	36.09/1
451 mm	-	692 mm	873 mm	787 mm	3.7 m	4.6 sqm	29.5 kg	1.04 cu.

COM	COL	1	2	3	4	5	6	7	8	9	10	11
3542	3622	3916	3978	4014	4085	4147	4174	4218	4280	4334	4396	4751

code 2100

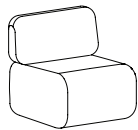

**Standard seat height
Concealed legs
Fully upholstered**

When using a combination of fabrics, specify the application by designating the appropriate letter, shown below, on the purchase order. Yardage shown must be used.

See terms and conditions for contrasting upholstery upcharges.

- A) One fabric for seat
yardage: 4.25 yds.
- C) One fabric for back cushion
yardage: 2.5 yds.

SCS Indoor Advantage™ Gold and LEVEL® 2 certified. See terms and conditions for instructions for tagging COM and additional environmental information.

Seat Height	Arm Height	W	D	H	Fabric	Leather	Weight	Cubes/Qty
15⅝"	-	30"	29½"	29⅞"	5.0 yds.	-	64 lbs.	36.09/1
403 mm	-	762 mm	749 mm	752 mm	4.6 m	-	29.1 kg	1.04 cu.

COM	COL	1	2	3	4	5	6	7	8	9	10	11
2074	0	2541	2619	2663	2752	2830	2863	2919	2997	3063	3141	3586

code 2105

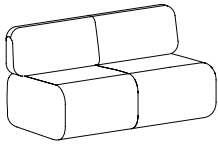

**Two-seat
Standard seat height
Concealed legs
Fully upholstered**

When using a combination of fabrics, specify the application by designating the appropriate letter, shown below, on the purchase order. Yardage shown must be used.

See terms and conditions for contrasting upholstery upcharges.

- A) One fabric for seat
yardage: 7.0 yds.
- C) One fabric for back cushion
yardage: 4.0 yds.

SCS Indoor Advantage™ Gold and LEVEL® 2 certified. See terms and conditions for instructions for tagging COM and additional environmental information.

Seat Height	Arm Height	W	D	H	Fabric	Leather	Weight	Cubes/Qty
15 7/8"	-	60"	29 1/2"	29 9/16"	9.0 yds.	-	130 lbs.	68.33/1
403 mm	-	1524 mm	749 mm	752 mm	8.2 m	-	59.1 kg	1.93 cu.

COM	COL	1	2	3	4	5	6	7	8	9	10	11
3627	0	4467	4607	4687	4847	4987	5047	5147	5287	5407	5547	6347

code 2107

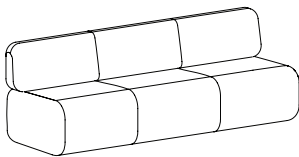

**Three-seat
Standard seat height
Concealed legs
Fully upholstered**

When using a combination of fabrics, specify the application by designating the appropriate letter, shown below, on the purchase order. Yardage shown must be used.

See terms and conditions for contrasting upholstery upcharges.

- A) One fabric for seat
yardage: 8.25 yds.
- C) One fabric for back cushion
yardage: 5.75 yds.

SCS Indoor Advantage™ Gold and LEVEL® 2 certified. See terms and conditions for instructions for tagging COM and additional environmental information.

Seat Height	Arm Height	W	D	H	Fabric	Leather	Weight	Cubes/Qty
15 7/8"	-	90"	29 1/2"	29 9/16"	12.25 yds.	-	193 lbs.	101.65/1
403 mm	-	2286 mm	749 mm	752 mm	11.2 m	-	87.7 kg	2.88 cu.

COM	COL	1	2	3	4	5	6	7	8	9	10	11
4486	0	5630	5820	5929	6147	6338	6419	6555	6746	6909	7100	8189

code 2140

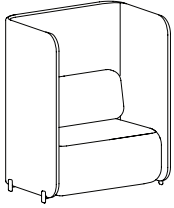

Single-seat with attached privacy wall
Standard seat height
Standard wall
Polished cast aluminum feet
Fully upholstered

Privacy wall on 1½" plinth base with four adjustable non-marring glides
 Standard with welt around wall perimeter
 Shipped assembled

When using a combination of fabrics, specify the application by designating the appropriate letter, shown below, on the purchase order. Yardage shown must be used.

See terms and conditions for contrasting upholstery upcharges.

- A) One fabric for seat
yardage: 4.25 yds.
- B) One fabric for wall
yardage: 10.0 yds.
- C) One fabric for back cushion
yardage: 2.5 yds.

SCS Indoor Advantage™ Gold and LEVEL® 2 certified. See terms and conditions for additional environmental information.

Seat Height	Seat Back Height	W	D	H	Fabric	Leather	Weight	Cubes/Qty
16¾"	30"	42½"	31"	52¾"	15.1 yds.	-	150 lbs.	59.21/1
416 mm	762 mm	1080 mm	787 mm	1340 mm	13.8 m	-	68.2 kg	1.68 cu.

COM	COL	1	2	3	4	5	6	7	8	9	10	11
5005	0	6415	6650	6784	7052	7287	7388	7556	7791	7992	8227	9569

code 2130

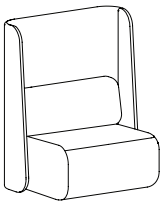

Single-seat with attached privacy wall
Standard seat height
Angled wall
Fully upholstered

Privacy wall on 1½" plinth base with four adjustable non-marring glides
 Standard with welt around wall perimeter
 Shipped assembled

When using a combination of fabrics, specify the application by designating the appropriate letter, shown below, on the purchase order. Yardage shown must be used.

See terms and conditions for contrasting upholstery upcharges.

- A) One fabric for seat
yardage: 4.25 yds.
- B) One fabric for wall
yardage: 10.0 yds.
- C) One fabric for back cushion
yardage: 2.5 yds.

SCS Indoor Advantage™ Gold and LEVEL® 2 certified. See terms and conditions for additional environmental information.

Seat Height	Seat Back Height	W	D	H	Fabric	Leather	Weight	Cubes/Qty
16¾"	30"	42"	31"	52¾"	15.1 yds.	-	150 lbs.	59.21/1
416 mm	762 mm	1067 mm	787 mm	1340 mm	13.8 m	-	68.2 kg	1.68 cu.

COM	COL	1	2	3	4	5	6	7	8	9	10	11
4315	0	5725	5960	6094	6362	6597	6698	6866	7101	7302	7537	8879

code 2145

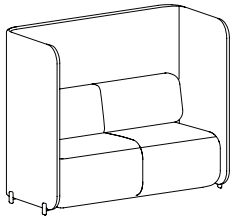

Two-seat with attached privacy wall
Standard seat height
Standard Wall
Polished cast aluminum feet
Fully upholstered

Privacy wall on 1½" plinth base with four adjustable non-marring glides
 Standard with welt around wall perimeter
 Shipped assembled

When using a combination of fabrics, specify the application by designating the appropriate letter, shown below, on the purchase order. Yardage shown must be used.

See terms and conditions for contrasting upholstery upcharges.

- A) One fabric for seat
yardage: 6.0 yds.
- B) One fabric for wall
yardage: 14.0 yds.
- C) One fabric for back cushion
yardage: 4.0 yds.

SCS Indoor Advantage™ Gold and LEVEL® 2 certified. See terms and conditions for additional finish and environmental information.

Seat Height	Seat Back Height	W	D	H	Fabric	Leather	Weight	Cubes/Qty
16¾"	30"	64½"	31"	52¾"	20.8 yds.	-	246 lbs.	88.21/1
416 mm	762 mm	1638 mm	787 mm	1340 mm	19.0 m	-	111.6 kg	2.50 cu.

COM	COL	1	2	3	4	5	6	7	8	9	10	11
6382	0	8324	8647	8832	9202	9526	9664	9895	10219	10496	10820	12669

code 2135

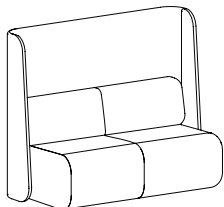

Two-seat with attached privacy wall
Standard seat height
Angled wall
Fully upholstered

Privacy wall on 1½" plinth base with four adjustable non-marring glides
 Standard with welt around wall perimeter
 Shipped assembled

When using a combination of fabrics, specify the application by designating the appropriate letter, shown below, on the purchase order. Yardage shown must be used.

See terms and conditions for contrasting upholstery upcharges.

- A) One fabric for seat
yardage: 6.0 yds.
- B) One fabric for wall
yardage: 14.0 yds.
- C) One fabric for back cushion
yardage: 4.0 yds.

SCS Indoor Advantage™ Gold and LEVEL® 2 certified. See terms and conditions for additional environmental information.

Seat Height	Seat Back Height	W	D	H	Fabric	Leather	Weight	Cubes/Qty
16¾"	30"	64"	31"	52¾"	20.8 yds.	-	246 lbs.	88.21/1
416 mm	762 mm	1638 mm	787 mm	1340 mm	19.0 m	-	111.6 kg	2.50 cu.

COM	COL	1	2	3	4	5	6	7	8	9	10	11
5692	0	7634	7957	8142	8512	8836	8974	9205	9529	9806	10130	11979

code 2147

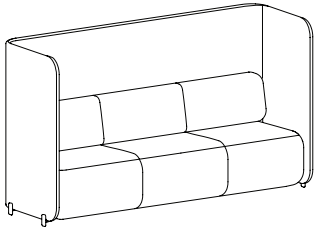

Three-seat with attached privacy wall
Standard Seat height
Standard wall
Polished cast aluminum feet
Fully upholstered

Privacy wall on 1½" plinth base with four adjustable non-marring glides
 Standard with welt around wall perimeter
 Shipped assembled

When using a combination of fabrics, specify the application by designating the appropriate letter, shown below, on the purchase order. Yardage shown must be used.

See terms and conditions for contrasting upholstery upcharges.

- A) One fabric for seat
yardage: 7.0 yds.
- B) One fabric for wall
yardage: 16.4 yds.
- C) One fabric for back cushion
yardage: 5.75 yds.

SCS Indoor Advantage™ Gold and LEVEL® 2 certified. See terms and conditions for additional environmental information.

Seat Height	Seat Back Height	W	D	H	Fabric	Leather	Weight	Cubes/Qty
16¾"	30"	94½"	31"	52¾"	27.25 yds.	-	316 lbs.	126.88'/1
416 mm	762 mm	2400 mm	787 mm	1340 mm	24.9 m	-	143.6 kg	3.60 cu.

COM	COL	1	2	3	4	5	6	7	8	9	10	11
8624	0	11168	11592	11834	12318	12742	12924	13227	13651	14014	14438	16860

code 2137

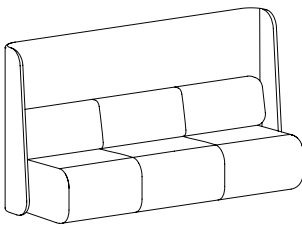

Three-seat with attached privacy wall
Standard seat height
Angled wall
Fully upholstered

Privacy wall on 1½" plinth base with four adjustable non-marring glides
 Standard with welt around wall perimeter
 Shipped assembled

When using a combination of fabrics, specify the application by designating the appropriate letter, shown below, on the purchase order. Yardage shown must be used.

See terms and conditions for contrasting upholstery upcharges.

- A) One fabric for seat
yardage: 7.0 yds.
- B) One fabric for wall
yardage: 16.4 yds.
- C) One fabric for back cushion
yardage: 5.75 yds.

SCS Indoor Advantage™ Gold and LEVEL® 2 certified. See terms and conditions for additional environmental information.

Seat Height	Seat Back Height	W	D	H	Fabric	Leather	Weight	Cubes/Qty
16¾"	30"	94"	31"	52¾"	27.25 yds.	-	316 lbs.	126.88'/1
416 mm	762 mm	2388 mm	787 mm	1340 mm	24.9 m	-	143.6 kg	3.60 cu.

COM	COL	1	2	3	4	5	6	7	8	9	10	11
7933	0	10477	10901	11143	11627	12051	12233	12536	12960	13323	13747	16169

code 2100C

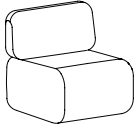

**Conference seat height
Concealed legs
Fully upholstered**

When using a combination of fabrics, specify the application by designating the appropriate letter, shown below, on the purchase order. Yardage shown must be used.

See terms and conditions for contrasting upholstery upcharges.

- A) One fabric for seat
yardage: 4.25 yds.
- C) One fabric for back cushion
yardage: 2.5 yds.

SCS Indoor Advantage™ Gold and LEVEL® 2 certified. See terms and conditions for additional environmental information.

Seat Height	Arm Height	W	D	H	Fabric	Leather	Weight	Cubes/Qty
18"	-	30"	29½"	29¾"	5.0 yds.	-	64 lbs.	35.16'/1
457 mm	-	762 mm	749 mm	752 mm	4.6 m	-	29.1 kg	1.0 cu.

COM	COL	1	2	3	4	5	6	7	8	9	10	11
2074	0	2541	2619	2663	2752	2830	2863	2919	2997	3063	3141	3586

code 2105C

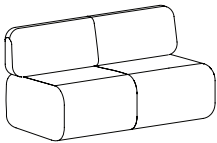

**Two-seat
Conference seat height
Concealed legs
Fully upholstered**

When using a combination of fabrics, specify the application by designating the appropriate letter, shown below, on the purchase order. Yardage shown must be used.

See terms and conditions for contrasting upholstery upcharges.

- A) One fabric for seat
yardage: 7.0 yds.
- C) One fabric for back cushion
yardage: 4.0 yds.

SCS Indoor Advantage™ Gold and LEVEL® 2 certified. See terms and conditions for additional environmental information.

Seat Height	Seat Back Height	W	D	H	Fabric	Leather	Weight	Cubes/Qty
18"	-	60"	29½"	29¾"	9.0 yds.	-	130 lbs.	68.33'/1
457 mm	-	1524 mm	749 mm	752 mm	8.2 m	-	59.1 kg	1.93 cu.

COM	COL	1	2	3	4	5	6	7	8	9	10	11
3627	0	4467	4607	4687	4847	4987	5047	5147	5287	5407	5547	6347

code 2107C

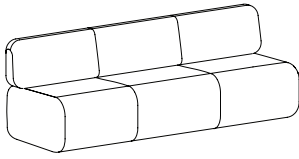

**Three-seat
Conference seat height
Concealed legs
Fully upholstered**

When using a combination of fabrics, specify the application by designating the appropriate letter, shown below, on the purchase order. Yardage shown must be used.

See terms and conditions for contrasting upholstery upcharges.

- A) One fabric for seat
yardage: 8.25 yds.
- C) One fabric for back cushion
yardage: 5.75 yds.

SCS Indoor Advantage™ Gold and LEVEL® 2 certified. See terms and conditions for additional environmental information.

Seat Height	Seat Back Height	W	D	H	Fabric	Leather	Weight	Cubes/Qty
18"	-	90"	29½"	29¾"	12.25 yds.	-	193 lbs.	101.65'/1
457 mm	-	2286 mm	749 mm	752 mm	11.2 m	-	87.7 kg	2.88 cu.

COM	COL	1	2	3	4	5	6	7	8	9	10	11
4486	0	5630	5820	5929	6147	6338	6419	6555	6746	6909	7100	8189

code 2140C

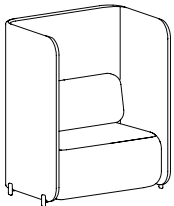

**Single seat with attached privacy wall
Conference seat height
Standard wall
Polished cast aluminum feet
Fully upholstered**

Privacy wall on 1½" plinth base with four adjustable non-marring glides
Standard with welt around wall perimeter
Shipped assembled

When using a combination of fabrics, specify the application by designating the appropriate letter, shown below, on the purchase order. Yardage shown must be used.

See terms and conditions for contrasting upholstery upcharges.

- A) One fabric for seat
yardage: 4.25 yds.
- B) One fabric for wall
yardage: 10.0 yds.
- C) One fabric for back cushion
yardage: 2.5 yds.

SCS Indoor Advantage™ Gold and LEVEL® 2 certified. See terms and conditions for additional finish and environmental information.

Seat Height	Seat Back Height	W	D	H	Fabric	Leather	Weight	Cubes/Qty
18½"	32½"	42½"	31"	52¾"	15.1 yds.	-	150 lbs.	59.21'/1
470 mm	816 mm	1080 mm	787 mm	1340 mm	13.8 m	-	68.2 kg	1.68 cu.

COM	COL	1	2	3	4	5	6	7	8	9	10	11
5005	0	6415	6650	6784	7052	7287	7388	7556	7791	7992	8227	9569

code 2130C

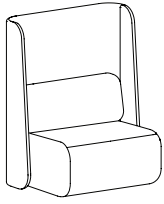

Single-seat with attached privacy wall
Conference seat height
Angled wall
Concealed legs
Fully upholstered

Privacy wall on 1½" plinth base with four adjustable non-marring glides
 Standard with welt around wall perimeter
 Shipped assembled

When using a combination of fabrics, specify the application by designating the appropriate letter, shown below, on the purchase order. Yardage shown must be used.

See terms and conditions for contrasting upholstery upcharges.

- A) One fabric for seat
yardage: 4.25 yds.
- B) One fabric for wall
yardage: 10.0 yds.
- C) One fabric for back cushion
yardage: 2.5 yds.

SCS Indoor Advantage™ Gold and LEVEL® 2 certified. See terms and conditions for additional environmental information.

Seat Height	Seat Back Height	W	D	H	Fabric	Leather	Weight	Cubes/Qty
18½"	32½"	42"	31"	52¾"	15.1 yds.	-	150 lbs.	59.21/1
470 mm	816 mm	1067 mm	787 mm	1340 mm	13.8 m	-	68.2 kg	1.68 cu.

COM	COL	1	2	3	4	5	6	7	8	9	10	11
4315	0	5725	5960	6094	6362	6597	6698	6866	7101	7302	7537	8879

code 2145C

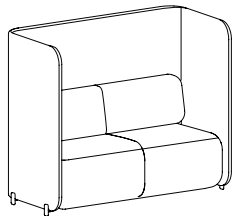

Two-seat with attached privacy wall
Conference seat height
Standard Wall
Polished cast aluminum feet
Fully upholstered

Privacy wall on 1½" plinth base with four adjustable non-marring glides
 Standard with welt around wall perimeter
 Shipped assembled

When using a combination of fabrics, specify the application by designating the appropriate letter, shown below, on the purchase order. Yardage shown must be used.

See terms and conditions for contrasting upholstery upcharges.

- A) One fabric for seat
yardage: 6.0 yds.
- B) One fabric for wall
yardage: 14.0 yds.
- C) One fabric for back cushion
yardage: 4.0 yds.

SCS Indoor Advantage™ Gold and LEVEL® 2 certified. See terms and conditions for additional environmental information.

Seat Height	Seat Back Height	W	D	H	Fabric	Leather	Weight	Cubes/Qty
18½"	32½"	64½"	31"	52¾"	20.8 yds.	-	246 lbs.	88.21/1
470 mm	816 mm	1638 mm	787 mm	1340 mm	19.0 m	-	111.6 kg	2.50 cu.

COM	COL	1	2	3	4	5	6	7	8	9	10	11
6382	0	8324	8647	8832	9202	9526	9664	9895	10219	10496	10820	12669

code 2135C

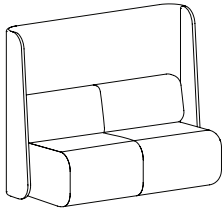

Two-seat with attached privacy wall
Conference seat height
Angled wall
Concealed legs
Fully upholstered

Privacy wall on 1½" plinth base with four adjustable non-marring glides
 Standard with welt around wall perimeter
 Shipped assembled

When using a combination of fabrics, specify the application by designating the appropriate letter, shown below, on the purchase order. Yardage shown must be used.

See terms and conditions for contrasting upholstery upcharges.

- A) One fabric for seat
yardage: 6.0 yds.
- B) One fabric for wall
yardage: 14.0 yds.
- C) One fabric for back cushion
yardage: 4.0 yds.

SCS Indoor Advantage™ Gold and LEVEL® 2 certified. See terms and conditions for additional environmental information.

Seat Height	Seat Back Height	W	D	H	Fabric	Leather	Weight	Cubes/Qty
18½"	32½"	64	31"	52½"	20.8 yds.	-	246 lbs.	88.21/1
470 mm	816 mm	1638 mm	787 mm	1340 mm	19.0 m	-	111.6 kg	2.50 cu.

COM	COL	1	2	3	4	5	6	7	8	9	10	11
5692	0	7634	7957	8142	8512	8836	8974	9205	9529	9806	10130	11979

code 2147C

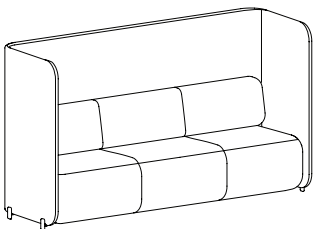

Three-seat with attached privacy wall
Conference Seat height
Standard wall
Polished cast aluminum feet
Fully upholstered

Privacy wall on 1½" plinth base with four adjustable non-marring glides
 Standard with welt around wall perimeter
 Shipped assembled

When using a combination of fabrics, specify the application by designating the appropriate letter, shown below, on the purchase order. Yardage shown must be used.

See terms and conditions for contrasting upholstery upcharges.

- A) One fabric for seat
yardage: 7.0 yds.
- B) One fabric for wall
yardage: 16.4 yds.
- C) One fabric for back cushion
yardage: 5.75 yds.

SCS Indoor Advantage™ Gold and LEVEL® 2 certified. See terms and conditions for additional environmental information.

Seat Height	Seat Back Height	W	D	H	Fabric	Leather	Weight	Cubes/Qty
18½"	32½"	94½"	31"	52½"	27.25 yds.	-	316 lbs.	126.88/1
470 mm	816 mm	2400 mm	787 mm	1340 mm	24.9 m	-	143.6 kg	3.60 cu.

COM	COL	1	2	3	4	5	6	7	8	9	10	11
8624	0	11168	11592	11834	12318	12742	12924	13227	13651	14014	14438	16860

code 2137C

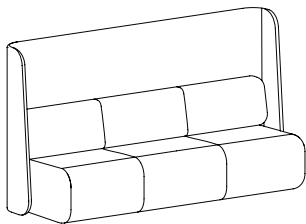

Three-seat with attached privacy wall
Conference seat height
Angled wall
Concealed legs
Fully upholstered

Privacy wall on 1½" plinth base with four adjustable non-marring glides
 Standard with welt around wall perimeter
 Shipped assembled

When using a combination of fabrics, specify the application by designating the appropriate letter, shown below, on the purchase order. Yardage shown must be used.

See terms and conditions for contrasting upholstery upcharges.

- A) One fabric for seat
yardage: 7.0 yds.
- B) One fabric for wall
yardage: 16.4 yds.
- C) One fabric for back cushion
yardage: 5.75 yds.

SCS Indoor Advantage™ Gold and LEVEL® 2 certified. See terms and conditions for additional environmental information.

Seat Height	Seat Back Height	W	D	H	Fabric	Leather	Weight	Cubes/Qty
18½"	32½"	94"	31"	52½"	27.25 yds.	-	316 lbs.	126.88/1
470 mm	816 mm	2388 mm	787 mm	1340 mm	24.9 m	-	143.6 kg	3.60 cu.

COM	COL	1	2	3	4	5	6	7	8	9	10	11
7933	0	10477	10901	11143	11627	12051	12233	12536	12960	13323	13747	16169

code modular privacy lounge

2160 - 2197 Code Modular Privacy Lounge

Code Modular Privacy Lounge: A system of modular units which can be combined to create expanded sofas, U-Shaped and L-Shaped configurations.

For complete information reference Code Modular Privacy Lounge in the lounge modular section of the price list.

cp.1 6501/6501B



Loop stitch cording
Upholstered

6501 Polished stainless steel base
6501B Brushed stainless steel base

A loop stitch cording traces the perimeter of the chair. Contrasting thread options are available. For thread color options reference CP.1/ Stitching on bernhardtdesign.com.

All Bernhardt Textiles leathers are suitable for application on this product. Firm, non-flexible leathers are not recommended. Available in leather, coated fabrics, suede, or felt only.

SCS Indoor Advantage™ Gold and LEVEL® 1 certified. See terms and conditions for additional environmental information.

Seat Height	Arm Height	W	D	H	Fabric	Leather	Weight	Cubes/Qty
16¾"	-	27"	33¼"	28½"	3.7 yds.	50.0'	45 lbs.	21.82/1
416 mm	-	686 mm	845 mm	724 mm	3.4 m	4.6 sqm	20.4 kg	.62 cu.

COM	COL	1	2	4	6	7
3586	3660	3932	3989	4088	4170	4211

cp.1 6501K



Matte black powder coat base
Loop stitch cording
Upholstered

A loop stitch cording traces the perimeter of the chair. Contrasting thread options are available. For thread color options reference CP.1/ Stitching on bernhardtdesign.com.

All Bernhardt Textiles leathers are suitable for application on this product. Firm, non-flexible leathers are not recommended. Available in leather, coated fabrics, suede or felt only.

SCS Indoor Advantage™ Gold and LEVEL® 1 certified. See terms and conditions for additional environmental information.

Seat Height	Arm Height	W	D	H	Fabric	Leather	Weight	Cubes/Qty
16½"		27"	33¼"	28½"	3.7 yds.	50.0'	45 lbs.	21.82'/1
416 mm		686 mm	845 mm	724 mm	3.4 m	4.6 sqm	20.4 kg	.62 cu.

COM	COL	1	2	4	6	7
3908	3982	4254	4311	4410	4492	4533

cp.2 6502/6502B



Upholstered
6502 Polished stainless steel base
6502B Brushed stainless steel base

Small horizontal or two-way patterns are not recommended.

SCS Indoor Advantage™ Gold and LEVEL® 1 certified. See terms and condition for additional environmental information.

Seat Height	Arm Height	W	D	H	Fabric	Leather	Weight	Cubes/Qty
16"	-	26½"	33¾"	28¾"	3.75 yds.	50.0'	45 lbs.	21.82'/1
6 mm	-	673 mm	841 mm	730 mm	3.4 m	4.6 sqm	20.4 kg	.62 cu.

COM	COL	1	2	3	4	5	6	7	8	9	10	11
2646	2721	2996	3055	3088	3155	3213	3238	3280	3338	3388	3446	3780

cp.2 6502K



Matte black powder coat base
Upholstered

Small horizontal or two-way patterns are not recommended.

SCS Indoor Advantage™ Gold and LEVEL® 1 certified. See terms and condition for additional environmental information.

Seat Height	Arm Height	W	D	H	Fabric	Leather	Weight	Cubes/Qty
16"	-	26½"	33¾"	28¾"	3.75 yds.	50.0'	45 lbs.	21.82'/1
6 mm	-	673 mm	841 mm	730 mm	3.4 m	4.6 sqm	20.4 kg	.62 cu.

COM	COL	1	2	3	4	5	6	7	8	9	10	11
2967	3042	3317	3376	3409	3476	3534	3559	3601	3659	3709	3767	4101

cup 1960-12

PLANK



Chrome or black powder coat frame
Upholstered polyethylene shell

Available in Plank approved textiles only.

Available with standard or felt glides.

ANSI/BIFMA certified.

Seat Height	Arm Height	W	D	H	Fabric	Leather	Weight	Cubes/Qty
15¾"	-	25¼"	26¾"	28"	1.0 yd	13.0'	26 lbs.	15.875/1
400 mm	-	642 mm	680 mm	712 mm	.91 m	1.2 sqm	11.8 kg	.45 cu.

COM/GRP1	GRP2	GRP3	GRP4	GRP5
1640	1724	1797	1941	1989

sku	seat shell color	frame finish	fabric	glides
1 9 6 0 - 1 2	01 black 02 white	01 black CH chrome	COM/GRP1 GRP2 GRP3 GRP4 GRP5	ST standard FT felt

diego 5682/5682C



Mobile chair with tab pull
Fully upholstered

5682 Weight-activated, self-Locking casters
5682C Standard casters

Standard with welt

When using a combination of fabrics or leathers, specify the application by designating the appropriate letter, shown below, on the purchase order. Yardage shown must be used.

See terms and conditions for contrasting upholstery and welt upcharges.

- A) One fabric or leather for inside seat and back panels
yardage: 2.25 yds. leather: 40.0 sq. ft.
- B) One fabric or leather for outside back and base panels
yardage: 3.25 yds. leather: 60.0 sq. ft.
- C) One fabric or leather for welt
yardage: 1.5 yds. leather: 10.0 sq. ft.
- D) One fabric for 1-20 tab pulls or one leather for 1-15 tab pulls
yardage: 0.5 yds. leather: 10.0 sq. ft.

Thin leather and thin coated fabrics are not suitable for application on this product.

SCS Indoor Advantage™ Gold and LEVEL® 2 certified. See terms and conditions for additional environmental information.

Seat Height	Arm Height	W	D	H	Fabric	Leather	Weight	Cubes/Qty
16½"	-	32¼"	31¾"	30½"	5.5 yds.	100.0'	83 lbs.	36.09/1
406 mm	-	819 mm	810 mm	775 mm	5.0 m	9.29 sqm	37.6 kg	1.04 cu.

COM	COL	1	2	3	4	5	6	7	8	9	10	11
3596	3706	4110	4195	4244	4342	4428	4464	4525	4611	4684	4770	5259

diego 5683



**Stationary chair
Fully upholstered**

Standard with welt
Non-marring glides

When using a combination of fabrics or leathers, specify the application by designating the appropriate letter, shown below, on the purchase order. Yardage shown must be used.

See terms and conditions for contrasting upholstery and welt upcharges.

- A) One fabric or leather for inside seat and back panels
yardage: 2.25 yds. leather: 40.0 sq. ft.
- B) One fabric or leather for outside back and base panels
yardage: 3.25 yds. leather: 60.0 sq. ft.
- C) One fabric or leather for welt
yardage: 1.5 yds. leather: 10.0 sq. ft.

Thin leather and thin coated fabrics are not suitable for application on this product.

SCS Indoor Advantage™ Gold and LEVEL® 2 certified. See terms and conditions for additional environmental information.

Seat Height	Arm Height	W	D	H	Fabric	Leather	Weight	Cubes/Qty
16½"	-	32¼"	31⅞"	30½"	5.5 yds.	100.0'	83 lbs.	36.09/1
406 mm	-	819 mm	810 mm	775 mm	5.0 m	9.29 sqm	37.6 kg	1.04 cu.

COM	COL	1	2	3	4	5	6	7	8	9	10	11
3283	3393	3797	3882	3931	4029	4115	4151	4212	4298	4371	4457	4946

elio 4862

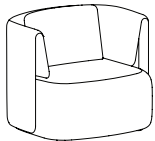

**Stationary
Fully upholstered**

Non-marring glides
Flange detail around front arm

Inside seat depth: 18½", Inside seat width: 24¼", Seat height at center: 17"

When using a combination of fabrics or leathers, specify the application by designating the appropriate letter, shown below, on the purchase order. Yardage shown must be used.

See terms and conditions for contrasting upholstery upcharges.

- A) One fabric or leather for seat
yardage: 3.0 yds. leather: 50 sq.ft.
- B) One fabric or leather for outside back and arm
yardage: 3.25 yds. leather: 53 sq. ft.
- C) One fabric or leather for pillow
yardage: 1.75 yds. leather: 29 sq. ft.

SCS Indoor Advantage™ Gold and LEVEL® 2 certified. See terms and conditions for additional environmental information.

Seat Height	Arm Height	W	D	H	Fabric	Leather	Weight	Cubes/Qty
16¾"	28½"	35¼"	31"	29½"	8.0 yds	132.0'	110 lbs	36.09/1
425 mm	724 mm	895 mm	787 mm	749 mm	7.3 m	12.3 sqm	49.9 kg	1.02 cu

COM	COL	1	2	3	4	5	6	7	8	9	10	11
3686	3846	4433	4558	4629	4771	4895	4949	5038	5162	5269	5393	6104

elio 4864

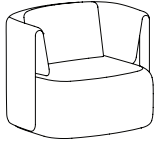

**Self-return swivel
Fully upholstered**

Flange detail around front arm

Inside seat depth: 18½", Inside seat width: 24¼", Seat height at center: 17"

When using a combination of fabrics or leathers, specify the application by designating the appropriate letter, shown below, on the purchase order. Yardage shown must be used.

See terms and conditions for contrasting upholstery upcharges.

- A) One fabric or leather for seat
yardage: 3.5 yds. leather: 57 sq. ft.
- B) One fabric or leather for outside back and arm
yardage: 3.25 yds. leather: 53 sq. ft.
- C) One fabric or leather for pillow
yardage: 1.75 yds. leather: 29 sq. ft.

SCS Indoor Advantage™ Gold and LEVEL® 2 certified. See terms and conditions for additional environmental information.

Seat Height	Arm Height	W	D	H	Fabric	Leather	Weight	Cubes/Qty
16¾"	28½"	35¼"	31"	29½"	8.0 yds	132.0'	122 lbs	36.09/1
425 mm	724 mm	895 mm	787 mm	749 mm	7.3 m	12.3 sqm	55.5 kg	1.02 cu

COM	COL	1	2	3	4	5	6	7	8	9	10	11
4033	4193	4780	4905	4976	5118	5242	5296	5385	5509	5616	5740	6451

finale 6510L/6510BL

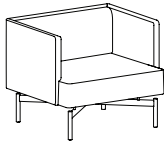

Upholstered

**6510L Polished stainless steel base
6510BL Brushed stainless steel base**

A loop stitch cording traces the perimeter of the chair. Contrasting thread options are available. For thread color options reference Finale/Stitching on bernhardtdesign.com.

When using a combination of fabrics or leathers, specify the application by designating the appropriate letter, shown below, on the purchase order. Yardage shown must be used.

See terms and conditions for contrasting upholstery upcharges.

- A) One fabric, leather, suede or felt for inside back, inside arms, seat and front panel.
yardage: 4.0 yds. leather: 65.0 sq. ft.
- B) One fabric, leather, suede or felt for shell.
yardage: 2.0 yds. leather: 35.0 sq. ft.

SCS Indoor Advantage™ Gold and LEVEL® 2 certified. See terms and condition for additional environmental information.

Seat Height	Arm Height	W	D	H	Fabric	Leather	Weight	Cubes/Qty
16½"	27½"	32⅝"	28¼"	27½"	6.0 yds.	100.0'	92 lbs.	36.08/1
419 mm	699 mm	829 mm	718 mm	699 mm	5.5 m	9.3 sqm	41.7 kg	1.02 cu.

COM	COL	1	2	3	4	5	6	7	8	9	10	11
3221	3341	3781	3875	3928	4035	4128	4168	4235	4328	4408	4501	5035

finale 6510KL

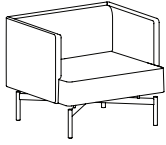

**Matte black powder coat base
Upholstered**

A loop stitch cording traces the perimeter of the chair. Contrasting thread options are available. For thread color options reference Finale/Stitching on bernhardtdesign.com.

When using a combination of fabrics or leathers, specify the application by designating the appropriate letter, shown below, on the purchase order. Yardage shown must be used.

See terms and conditions for contrasting upholstery upcharges.

- A) One fabric, leather, suede, or felt for inside back, inside arms, seat and front panel.
yardage: 4.0 yds. leather: 65.0 sq. ft.
- B) One fabric, leather, suede, or felt for shell.
yardage: 2.0 yds. leather: 35.0 sq. ft.

SCS Indoor Advantage™ Gold and LEVEL® 2 certified. See terms and condition for additional environmental information.

Seat Height	Arm Height	W	D	H	Fabric	Leather	Weight	Cubes/Qty
16½"	27½"	32¾"	28¼"	27½"	6.0 yds.	100.0'	92 lbs.	36.08'/1
419 mm	699 mm	829 mm	718 mm	699 m	5.5 m	9.3 sqm	41.7 kg	1.02 cu.

COM	COL	1	2	3	4	5	6	7	8	9	10	11
3542	3662	4102	4196	4249	4356	4449	4489	4556	4649	4729	4822	5356

finale 6517L/6517BL

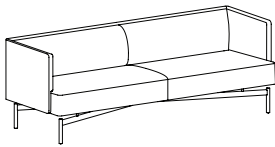

**Three-seat
Upholstered**

**6517L Polished stainless steel base
6517BL Brushed stainless steel base**

A loop stitch cording traces the perimeter of the chair. Contrasting thread options are available. For thread color options reference Finale/Stitching on bernhardtdesign.com.

When using a combination of fabrics or leathers, specify the application by designating the appropriate letter, shown below, on the purchase order. Yardage shown must be used.

See terms and conditions for contrasting upholstery upcharges.

- A) One fabric, leather, suede, or felt for inside back, inside arms, seat and front panel.
yardage: 6.25 yds. leather: 105.0 sq. ft.
- B) One fabric, leather, suede, or felt for shell.
yardage: 4.0 yds. leather: 65.0 sq. ft.

SCS Indoor Advantage™ Gold and LEVEL® 2 certified. See terms and condition for additional environmental information.

Seat Height	Arm Height	W	D	H	Fabric	Leather	Weight	Cubes/Qty
16½"	27½"	80"	28¼"	27½"	10.25 yds.	150.0'	190 lbs.	80.67'/1
419 mm	699 mm	2032 mm	718 mm	699 m	9.4 m	14.0 sqm	86.2 kg	2.28 cu.

COM	COL	1	2	3	4	5	6	7	8	9	10	11
5634	5839	6591	6751	6842	7024	7183	7252	7366	7525	7662	7821	8732

finale 6517KL

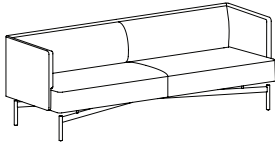

Three-seat Upholstered Matte black powder coat base

A loop stitch cording traces the perimeter of the chair. Contrasting thread options are available. For thread color options reference Finale/Stitching on bernhardtdesign.com.

When using a combination of fabrics or leathers, specify the application by designating the appropriate letter, shown below, on the purchase order. Yardage shown must be used.

See terms and conditions for contrasting upholstery upcharges.

Chair interior back pads, arm pads, and seat are available in any approved COM, COL or Bernhardt Textiles.

A) One fabric, leather, suede, or felt for inside back, inside arms, seat and front panel.
yardage: 6.25 yds. leather: 105.0 sq. ft.

Sofa shell is available in any approved COM, COL or Bernhardt Textiles

B) One fabric, leather, suede, or felt for shell.
yardage: 4.0 yds. leather: 65.0 sq. ft.

SCS Indoor Advantage™ Gold and LEVEL® 2 certified. See terms and condition for additional environmental information.

Seat Height	Arm Height	W	D	H	Fabric	Leather	Weight	Cubes/Qty
16½"	27½"	80"	28¼"	27½"	10.25 yds.	150.0'	190 lbs.	80.67/1
419 mm	699 mm	2032 mm	718 mm	699 mm	9.4 m	14.0 sqm	86.2 kg	2.28 cu.

COM	COL	1	2	3	4	5	6	7	8	9	10	11
6115	6320	7072	7232	7323	7505	7664	7733	7847	8006	8143	8302	9213

gaia 2202

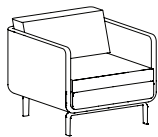

High arm Upholstered Polished aluminum base with levelers

Inside seat depth: 23¾"

When using a combination of fabrics or leathers, specify the application by designating the appropriate letter, shown below, on the purchase order. Yardage shown must be used.

See terms and conditions for contrasting upholstery upcharges.

A) One fabric or leather for seat cushion, back cushion and front panel
yardage: 4.75 yds. leather: 84.0 sq. ft.

B) One fabric or leather for shell
yardage: 4.5 yds. leather: 78.0 sq. ft.

SCS Indoor Advantage™ Gold and LEVEL® 2 certified. See terms and conditions for additional environmental information.

Seat Height	Arm Height	W	D	H	Fabric	Leather	Weight	Cubes/Qty
17½"	25¼"	31½"	33"	29½"	7.3 yds.	144.0'	75 lbs.	36.09/1
445 mm	654 mm	790 mm	838 mm	749 mm	6.7 m	13.4 sqm	34.0 kg	1.04 cu.

COM	COL	1	2	3	4	5	6	7	8	9	10	11
3734	3880	4416	4529	4594	4724	4838	4886	4967	5081	5178	5292	5941

gaia 2205

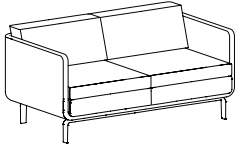

**Two-seat
High arm
Polished aluminum base with levelers
Upholstered**

Inside seat depth: 23¾"

When using a combination of fabrics or leathers, specify the application by designating the appropriate letter, shown below, on the purchase order. Yardage shown must be used.

See terms and conditions for contrasting upholstery upcharges.

- A) One fabric or leather for seat cushion, back cushion and front panel
yardage: 7.5 yds. leather: 144.0 sq. ft.
- B) One fabric or leather for shell
yardage: 6.1 yds. leather: 114.0 sq. ft.

SCS Indoor Advantage™ Gold and LEVEL® 2 certified. See terms and conditions for additional finish and environmental information.

Seat Height	Arm Height	W	D	H	Fabric	Leather	Weight	Cubes/Qty
17½"	-	59½"	33"	29½"	13.5 yds.	270.0'	135 lbs.	68.33'/1
445 mm	654 mm	1502 mm	838 mm	749 mm	12.3 m	25.1 sqm	61.2 kg	1.93 cu.

COM	COL	1	2	3	4	5	6	7	8	9	10	11
6213	6483	7473	7683	7803	8043	8253	8343	8493	8703	8883	9093	10293

gaia 2207

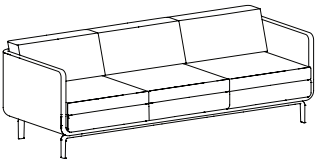

**Three-seat
High arm
Polished aluminum base with levelers
Upholstered**

Inside seat depth: 23¾"

When using a combination of fabrics or leathers, specify the application by designating the appropriate letter, shown below, on the purchase order. Yardage shown must be used.

See terms and conditions for contrasting upholstery upcharges.

- A) One fabric or leather for seat cushion, back cushion and front panel
yardage: 11.5 yds. leather: 210.0 sq. ft.
- B) One fabric or leather for shell
yardage: 8.1 yds. leather: 132.0 sq. ft.

SCS Indoor Advantage™ Gold and LEVEL® 2 certified. See terms and conditions for additional environmental information.

Seat Height	Arm Height	W	D	H	Fabric	Leather	Weight	Cubes/Qty
17½"	25¾"	87¼"	33"	29½"	17.6 yds.	336.0'	150 lbs.	101.65'/1
445 mm	654 mm	2216 mm	838 mm	749 mm	16.1 m	31.2 sqm	67.0 kg	2.88 cu.

COM	COL	1	2	3	4	5	6	7	8	9	10	11
8280	8632	9923	10197	10353	10666	10940	11057	11253	11527	11761	12035	13600

gaia 2302

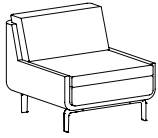

**Low arm
Polished aluminum base with levelers
Upholstered**

Inside seat depth: 23¾"

When using a combination of fabrics or leathers, specify the application by designating the appropriate letter, shown below, on the purchase order. Yardage shown must be used.

See terms and conditions for contrasting upholstery upcharges.

- A) One fabric or leather for seat cushion, back cushion and front panel
yardage: 4.75 yds. leather: 84.0 sq. ft.
- B) One fabric or leather for shell
yardage: 4.0 yds. leather: 78.0 sq. ft.

SCS Indoor Advantage™ Gold and LEVEL® 2 certified. See terms and conditions for additional environmental information.

Seat Height	Arm Height	W	D	H	Fabric	Leather	Weight	Cubes/Qty
17½"	17½"	31⅞"	33"	29½"	7.3 yds.	132.0'	75 lbs.	36.09'/1
445 mm	445 mm	791 mm	838 mm	749 mm	6.7 m	12.3 sqm	34.0 kg	1.04 cu.

COM	COL	1	2	3	4	5	6	7	8	9	10	11
3734	3880	4416	4529	4594	4724	4838	4886	4967	5081	5178	5292	5941

gaia 2305

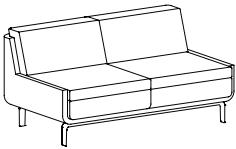

**Two-seat
Low arm
Polished aluminum base with levelers
Upholstered**

Inside seat depth: 23¾"

When using a combination of fabrics or leathers, specify the application by designating the appropriate letter, shown below, on the purchase order. Yardage shown must be used.

See terms and conditions for contrasting upholstery upcharges.

- A) One fabric or leather for seat cushion, back cushion and front panel
yardage: 7.5 yds. leather: 144.0 sq. ft.
- B) One fabric or leather for shell
yardage: 6.1 yds. leather: 114.0 sq. ft.

SCS Indoor Advantage™ Gold and LEVEL® 2 certified. See terms and conditions for additional environmental information.

Seat Height	Arm Height	W	D	H	Fabric	Leather	Weight	Cubes/Qty
17½"	17½"	59⅞"	33"	29½"	13.5 yds.	270.0'	135 lbs.	68.33'/1
445 mm	445 mm	1502 mm	838 mm	749 mm	12.3 m	25.1 sqm	61.2 kg	1.93 cu.

COM	COL	1	2	3	4	5	6	7	8	9	10	11
6213	6483	7473	7683	7803	8043	8253	8343	8493	8703	8883	9093	10293

gaia 2307

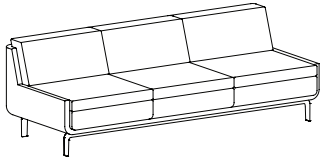

**Three-seat
Low arm
Polished aluminum base with levelers
Upholstered**

Inside seat depth: 23¾"

When using a combination of fabrics or leathers, specify the application by designating the appropriate letter, shown below, on the purchase order. Yardage shown must be used.

See terms and conditions for contrasting upholstery upcharges.

- A) One fabric or leather for seat cushion, back cushion and front panel
yardage: 11.5 yds. leather: 210.0 sq. ft.
- B) One fabric or leather for shell
yardage: 8.1 yds. leather: 132.0 sq. ft.

SCS Indoor Advantage™ Gold and LEVEL® 2 certified. See terms and conditions for additional environmental information.

Seat Height	Arm Height	W	D	H	Fabric	Leather	Weight	Cubes/Qty
17½"	17½"	87¼"	33"	29½"	17.6 yds.	336.0'	150 lbs.	101.65'/1
445 mm	445 mm	2216 mm	838 mm	749 mm	16.1 m	31.2 sqm	67.0 kg	2.88 cu.

COM	COL	1	2	3	4	5	6	7	8	9	10	11
8280	8632	9923	10197	10353	10666	10940	11057	11253	11527	11761	12035	13600

gaia modular lounge

2215-2291 Gaia Modular Lounge

Reference Gaia in the lounge - modular section of the price list for complete information on coordinating sectional components.

glasgow 6492

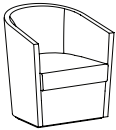

**Stationary chair
Fully upholstered**

When using a combination of fabrics or leathers, specify the application by designating the appropriate letter, shown below, on the purchase order. Yardage shown must be used.

See terms and conditions for contrasting upholstery upcharges.

- A) One fabric or leather for seat
yardage: 1.0 yds. leather: 32.4 sq. ft.
- B) One fabric or leather for inside and outside back, sides, inside arms and front panel
yardage: 4.25 yds. leather: 56.7 sq. ft.

SCS Indoor Advantage™ Gold and LEVEL® 2 certified. See terms and conditions for additional environmental information.

Seat Height	Arm Height	W	D	H	Fabric	Leather	Weight	Cubes/Qty
17½"	25½"	27½"	25½"	30½"	5.0 yds	75.0'	65 lbs	22.69'/1
435 mm	648 mm	695 mm	651 mm	765 mm	4.6 m	7.0 sqm	29.5 kg	.64 cu

COM	COL	1	2	3	4	5	6	7	8	9	10	11
2338	2438	2805	2883	2927	3016	3094	3127	3183	3261	3327	3405	3850

glasgow 6493

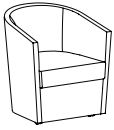

**Chair with casters
Fully upholstered**

When using a combination of fabrics or leathers, specify the application by designating the appropriate letter, shown below, on the purchase order. Yardage shown must be used.

See terms and conditions for contrasting upholstery upcharges.

- A) One fabric or leather for seat
yardage: 1.0 yds. leather: 32.4 sq. ft.
- B) One fabric or leather for inside and outside back, sides, inside arms and front panel
yardage: 4.25 yds. leather: 56.7 sq. ft.

SCS Indoor Advantage™ Gold and LEVEL® 2 certified. See terms and conditions for additional environmental information.

Seat Height	Arm Height	W	D	H	Fabric	Leather	Weight	Cubes/Qty
17½"	25½"	27¾"	25¾"	30¾"	5.0 yds	75.0'	65 lbs	22.69/1
435 mm	648 mm	695 mm	651 mm	765 mm	4.6 m	7.0 sqm	29.5 kg	.64 cu

COM	COL	1	2	3	4	5	6	7	8	9	10	11
2496	2596	2963	3041	3085	3174	3252	3285	3341	3419	3485	3563	4008

glasgow 6494

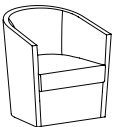

**Self-return swivel
Fully upholstered**

When using a combination of fabrics or leathers, specify the application by designating the appropriate letter, shown below, on the purchase order. Yardage shown must be used.

See terms and conditions for contrasting upholstery upcharges.

- A) One fabric or leather for seat
yardage: 1.0 yds. leather: 32.4 sq. ft.
- B) One fabric or leather for inside and outside back, sides, inside arms and front panel
yardage: 4.25 yds. leather: 56.7 sq. ft.

SCS Indoor Advantage™ Gold and LEVEL® 2 certified. See terms and conditions for additional environmental information.

Seat Height	Arm Height	W	D	H	Fabric	Leather	Weight	Cubes/Qty
17½"	25½"	27¾"	25¾"	30¾"	5.0 yds	75.0'	71 lbs	22.69/1
435 mm	648 mm	695 mm	651 mm	765 mm	4.6 m	7.0 sqm	32.2 kg	.64 cu

COM	COL	1	2	3	4	5	6	7	8	9	10	11
2741	2841	3208	3286	3330	3419	3497	3530	3586	3664	3730	3808	4253

harper 1889

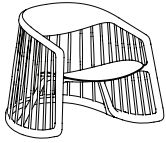

Cherry frame with maple tapered spindles

Available in a natural clear coat finish only
 Flange stitched seat pad
 Available in leather or suede only

Seat Height	Arm Height	W	D	H	Fabric	Leather	Weight	Cubes/Qty
15¾"	24½"	29"	31¾"	27"	-	12.5'	47 lbs.	36.09'/1
400 mm	622 mm	737 mm	806 mm	686 mm	-	1.2 sqm	21.3 kg	1.04 cu.

COL
5155

ibis 1095/1095K

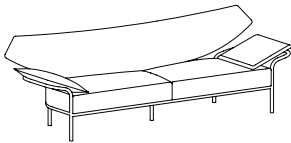

**Two-seat
 1" tubular stainless steel frame
 Upholstered**

1095 Polished stainless steel base
1095K Matte black powder coat base

Attached pillows
 Saddle stitch detail on seat back
 Two inner support legs

SCS Indoor Advantage™ Gold and LEVEL® 2 certified. See terms and conditions for additional environmental information.

Seat Height	Arm Height	W	D	H	Fabric	Leather	Weight	Cubes/Qty
16"	22¼"	92"	26½"	31"	8.0 yds.	130.0'	200 lbs.	101.65'/1
406 mm	565 mm	2337 mm	673 mm	787 mm	7.3 m	12.1 sqm	90.7 kg	2.88 cu.

COM	COL	1	2	3	4	5	6	7	8	9	10	11
7810	7970	8557	8682	8753	8895	9019	9073	9162	9286	9393	9517	10228

ibis 1097/1097K

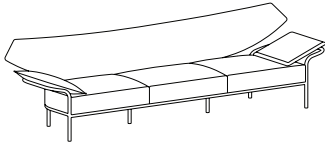

**Three-seat
1" tubular stainless steel frame
Upholstered**

**1097 Polished stainless steel base
1097K Matte black powder coat base**

Attached pillows
Saddle stitch detail on seat back
Two inner support legs

SCS Indoor Advantage™ Gold and LEVEL® 2 certified. See terms and conditions for additional environmental information.

Seat Height	Arm Height	W	D	H	Fabric	Leather	Weight	Cubes/Qty
16"	22¼"	108"	26½"	31"	9.0 yds.	145.0'	210 lbs.	97.96'/1
406 mm	565 mm	2743 mm	673 mm	787 mm	8.2 m	13.47 sqm	95.3 kg	2.78 cu.

COM	COL	1	2	3	4	5	6	7	8	9	10	11
10154	10334	10994	11134	11214	11374	11514	11574	11674	11814	11934	12074	12874

item modular lounge

5900L - 5905 Item Modular Lounge

Item: A modular seating collection that creates free designs that twist, rise and fall creating a final assembly sculptured from both the plan and elevation views. Item is offered in 10 different modules that range in shape and heights.

For complete information reference Item in the lounge/modular section of the price list.

jackson 4680

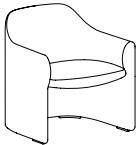

**Stationary chair
Fully upholstered**

Non-marring glides
Standard with welt around perimeter

Inside seat width: 22¼", Inside seat depth: 21¼", Inside arm height: 6½"

When using a combination of fabrics or leathers, specify the application by designating the appropriate letter, shown below, on the purchase order. Yardage shown must be used.

See terms and conditions for contrasting upholstery and welt upcharges.

- A) One fabric or leather for seat
yardage: 1.0 yds. leather: 18.0 sq. ft.
- B) One fabric or leather for inside back
yardage: 2.0 yds. leather: 36.0 sq. ft.
- C) One fabric or leather for outside back
yardage: 2.0 yds. leather: 36.0 sq. ft.
- D) One fabric or leather for welt
yardage: 1.0 yds. leather: 18.0 sq. ft.

SCS Indoor Advantage™ Gold and LEVEL® 2 certified. See terms and conditions for additional environmental information.

Seat Height	Arm Height	W	D	H	Fabric	Leather	Weight	Cubes/Qty
18"	24¾"	29½"	27¼"	30¾"	6 yds.	108.0'	80.0 lbs.	36.09'/1
458 mm	629 mm	750 mm	693 mm	772 mm	5.5 m	10.0 sqm	36.3 kg	1.03 cu.

COM	COL	1	2	3	4	5	6	7	8	9	10	11
2380	2500	2940	3034	3087	3194	3287	3327	3394	3487	3567	3660	4194

jackson 4680 left hand tablet



**Stationary chair with left hand tablet
Fully upholstered**

Non-marring glides
Standard with welt around the perimeter

Inside seat width: 22¼", Inside seat depth: 21¼", Inside arm height: 6½", Tablet height from floor: 26⅝"

Oblong tablet 10¼"w x 15"d x ¾" thick. 360° rotation around center of arm. Tablet is designed for light weight use and is not recommended for high use areas. Dimensions include tablet arm in user position. Maximum rotation dimensions: 34"d, 35⅝"w.

When using a combination of fabrics or leathers, specify the application by designating the appropriate letter, shown below, on the purchase order. Yardage shown must be used.

See terms and conditions for contrasting upholstery and welt upcharges.

- A) One fabric or leather for seat
yardage: 1.0 yds. leather: 18.0 sq. ft.
- B) One fabric or leather for inside back
yardage: 2.0 yds. leather: 36.0 sq. ft.
- C) One fabric or leather for outside back
yardage: 2.0 yds. leather: 36.0 sq. ft.
- D) One fabric or leather for welt
yardage: 1.0 yds. leather: 18.0 sq. ft.

SCS Indoor Advantage™ Gold and LEVEL® 2 certified. See terms and conditions for additional environmental information.

Seat Height	Arm Height	W	D	H	Fabric	Leather	Weight	Cubes/Qty
18"	24¾"	32⅝"	27¼"	30⅝"	6 yds.	108.0'	80.0 lbs.	36.09/1
458 mm	629 mm	750 mm	693 mm	772 mm	5.5 m	10.0 sqm	36.3 kg	1.03 cu.

COM	COL	1	2	3	4	5	6	7	8	9	10	11
2856	2976	3416	3510	3563	3670	3763	3803	3870	3963	4043	4136	4670

sku

4	6	8	0	L								

laminate finish

- WH** #671 designer white laminate, wilsonart D354-60 matte finish
- RC** #685 raw chestnut laminate, wilsonart 7975k-12 soft grain finish
- WT** #680 walnut heights laminate, wilsonart 7965k-12 soft grain finish

--	--

jackson 4680 right hand tablet **Stationary chair with right hand tablet**
Fully upholstered



Non-marring glides
 Standard with welt around the perimeter

Inside seat width: 22¼", Inside seat depth: 21¼", Inside arm height: 6½", Tablet height from floor: 26⅝"

Oblong tablet 10¼"w x 15"d x¾" thick. 360° rotation around center of arm. Tablet is designed for light weight use and is not recommended for high use areas. Dimensions include tablet arm in user position. Maximum rotation dimensions: 34"d, 35⅝"w.

When using a combination of fabrics or leathers, specify the application by designating the appropriate letter, shown below, on the purchase order. Yardage shown must be used.

See terms and conditions for contrasting upholstery and welt upcharges.

- A) One fabric or leather for seat
 yardage: 1.0 yds. leather: 18.0 sq. ft.
- B) One fabric or leather for inside back
 yardage: 2.0 yds. leather: 36.0 sq. ft.
- C) One fabric or leather for outside back
 yardage: 2.0 yds. leather: 36.0 sq. ft.
- D) One fabric or leather for welt
 yardage: 1.0 yds. leather: 18.0 sq. ft.

SCS Indoor Advantage™ Gold and LEVEL® 2 certified. See terms and conditions for additional environmental information.

Seat Height	Arm Height	W	D	H	Fabric	Leather	Weight	Cubes/Qty
18"	24¾"	32⅝"	27¼"	30⅝"	6 yds.	108.0'	80.0 lbs.	36.09/1
458 mm	629 mm	750 mm	693 mm	772 mm	5.5 m	10.0 sqm	36.3 kg	1.03 cu.

COM	COL	1	2	3	4	5	6	7	8	9	10	11
2856	2976	3416	3510	3563	3670	3763	3803	3870	3963	4043	4136	4670

sku

4	6	8	0	R									

laminate finish

- WH** #671 designer white laminate, wilsonart D354-60 matte finish
- RC** #685 raw chestnut laminate, wilsonart 7975k-12 soft grain finish
- WT** #680 walnut heights laminate, wilsonart 7965k-12 soft grain finish

--	--

jackson 4681

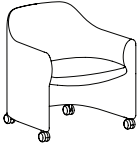

**Mobile chair
Fully upholstered**

Casters
Standard with welt around the perimeter

Inside seat width: 22¼", Inside seat depth: 21¼", Inside arm height: 6½"

When using a combination of fabrics or leathers, specify the application by designating the appropriate letter, shown below, on the purchase order. Yardage shown must be used.

See terms and conditions for contrasting upholstery and welt upcharges.

- A) One fabric or leather for seat
yardage: 1.0 yds. leather: 18.0 sq. ft.
- B) One fabric or leather for inside back
yardage: 2.0 yds. leather: 36.0 sq. ft.
- C) One fabric or leather for outside back
yardage: 2.0 yds. leather: 36.0 sq. ft.
- D) One fabric or leather for welt
yardage: 1.0 yds. leather: 18.0 sq. ft.

SCS Indoor Advantage™ Gold and LEVEL® 2 certified. See terms and conditions for additional environmental information.

Seat Height	Arm Height	W	D	H	Fabric	Leather	Weight	Cubes/Qty
18"	24¾"	29½"	27¼"	30¾"	6 yds.	108.0'	80.0 lbs.	36.09/1
458 mm	629 mm	750 mm	693 mm	772 mm	5.5 m	10.0 sqm	36.3 kg	1.03 cu.

COM	COL	1	2	3	4	5	6	7	8	9	10	11
2530	2650	3090	3184	3237	3344	3437	3477	3544	3637	3717	3810	4344

jackson 4681 left hand tablet

**Mobile chair with left hand tablet
Fully upholstered**

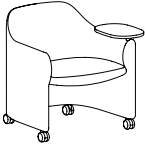

Casters
Standard with welt around the perimeter

Inside seat width: 22¼", Inside seat depth: 21¼", Inside arm height: 6½", Tablet height from floor: 26⅝"

Oblong tablet 10¼"w x 15"d x ¾" thick. 360° rotation around center of arm. Tablet is designed for light weight use and is not recommended for high use areas. Dimensions include tablet arm in user position. Maximum rotation dimensions: 34"d, 35⅝"w.

When using a combination of fabrics or leathers, specify the application by designating the appropriate letter, shown below, on the purchase order. Yardage shown must be used.

See terms and conditions for contrasting upholstery and welt upcharges.

- A) One fabric or leather for seat
yardage: 1.0 yds. leather: 18.0 sq. ft.
- B) One fabric or leather for inside back
yardage: 2.0 yds. leather: 36.0 sq. ft.
- C) One fabric or leather for outside back
yardage: 2.0 yds. leather: 36.0 sq. ft.
- D) One fabric or leather for welt
yardage: 1.0 yds. leather: 18.0 sq. ft.

SCS Indoor Advantage™ Gold and LEVEL® 2 certified. See terms and conditions for additional environmental information.

Seat Height	Arm Height	W	D	H	Fabric	Leather	Weight	Cubes/Qty
18"	24¾"	32⅝"	27¼"	30⅝"	6 yds.	108.0'	80.0 lbs.	36.09/1
458 mm	629 mm	750 mm	693 mm	772 mm	5.5 m	10.0 sqm	36.3 kg	1.03 cu.

COM	COL	1	2	3	4	5	6	7	8	9	10	11
3006	3126	3566	3660	3713	3820	3913	3953	4020	4113	4193	4286	4820

sku

4	6	8	1	L									

laminate finish

- WH** #671 designer white laminate, wilsonart D354-60 matte finish
- RC** #685 raw chestnut laminate, wilsonart 7975k-12 soft grain finish
- WT** #680 walnut heights laminate, wilsonart 7965k-12 soft grain finish

--	--

jackson 4681 right hand tablet Mobile chair with right hand tablet Fully upholstered



Casters
Standard with welt around the perimeter

Inside seat width: 22¹/₄", Inside seat depth: 21¹/₄", Inside arm height: 6¹/₂", Tablet height from floor: 26³/₈"

Oblong tablet 10¹/₄"w x 15"d x³/₄" thick. 360° rotation around center of arm. Tablet is designed for light weight use and is not recommended for high use areas. Dimensions include tablet arm in user position. Maximum rotation dimensions: 34"d, 35¹/₈"w.

When using a combination of fabrics or leathers, specify the application by designating the appropriate letter, shown below, on the purchase order. Yardage shown must be used.

See terms and conditions for contrasting upholstery and welt upcharges.

- A) One fabric or leather for seat
yardage: 1.0 yds. leather: 18.0 sq. ft.
- B) One fabric or leather for inside back
yardage: 2.0 yds. leather: 36.0 sq. ft.
- C) One fabric or leather for outside back
yardage: 2.0 yds. leather: 36.0 sq. ft.
- D) One fabric or leather for welt
yardage: 1.0 yds. leather: 18.0 sq. ft.

SCS Indoor Advantage™ Gold and LEVEL® 2 certified. See terms and conditions for additional environmental information.

Seat Height	Arm Height	W	D	H	Fabric	Leather	Weight	Cubes/Qty
18"	24 ³ / ₄ "	32 ⁵ / ₈ "	27 ¹ / ₄ "	30 ³ / ₈ "	6 yds.	108.0'	80.0 lbs.	36.09/1
458 mm	629 mm	750 mm	693 mm	772 mm	5.5 m	10.0 sqm	36.3 kg	1.03 cu.

COM	COL	1	2	3	4	5	6	7	8	9	10	11
3006	3126	3566	3660	3713	3820	3913	3953	4020	4113	4193	4286	4820

sku

4	6	8	1	R	

laminate finish

- WH** #671 designer white laminate, wilsonart D354-60 matte finish
- RC** #685 raw chestnut laminate, wilsonart 7975k-12 soft grain finish
- WT** #680 walnut heights laminate, wilsonart 7965k-12 soft grain finish

--	--

land 1100-00

PLANK



Molded polyethylene rotational shell

Indoor and outdoor use

Available with standard or felt glides.

ANSI/BIFMA certified.

Seat Height	Arm Height	W	D	H	Fabric	Leather	Weight	Cubes/Qty
15"	-	44½"	32½"	40½"	-	-	47 lbs.	41/1
381 mm	-	1121 mm	829 mm	1020 mm	-	-	21.3 kg	1.17 cu.

List Price
1471

<p>sku</p> <p>1 1 0 0 - 0 0</p>	<p>frame finish</p> <p>01 black 20 signal grey 02 white 28 basalt grey 03 traffic red 06 yellow green</p>	<p>glides</p> <p>ST standard FT felt</p>
--	---	--

land 1150-00

PLANK



Fully upholstered

Injected polyurethane foam over molded polyethylene shell.

Available in Plank approved textiles only.

Available with standard or felt glides.

Seat Height	Arm Height	W	D	H	Fabric	Leather	Weight	Cubes/Qty
15"	-	44½"	32½"	40½"	4.0 yds	90.0'	62 lbs.	41/1
381 mm	-	1121 mm	829 mm	1020 mm	3.7 m	8.4 sqm	28.1 kg	1.17 cu.

COM/GRP1	GRP2	GRP3	GRP4	GRP5
3942	4204	4466	4740	6905

<p>sku</p> <p>1 1 5 0 - 0 0</p>	<p>fabric</p> <p>COM/GRP1 GRP2 GRP3 GRP4 GRP5</p>	<p>glides</p> <p>ST standard FT felt</p>
--	--	--

land 1050-00

PLANK

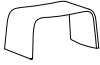

Ottoman
Molded polyethylene rotational shell

Indoor and outdoor use

Available with standard or felt glides.

Seat Height	Arm Height	W	D	H	Fabric	Leather	Weight	Cubes/Qty
15"	-	29½"	17¾"	15"	-	-	25 lbs.	7.125/1
381 mm	-	740 mm	442 mm	381 mm	-	-	11.3 kg	.21 cu.

List Price
697

<p>sku</p> <p>1 0 5 0 - 0 0</p>	<p>frame finish</p> <p>01 black 20 signal grey 02 white 28 basalt grey 03 traffic red 06 yellow green</p>	<p>glides</p> <p>ST standard FT felt</p>
---	--	---

lily 3302

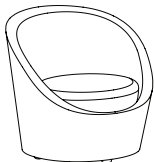

Stationary
Fully upholstered

Felt and leather applications will have saddle stitch detail on the outside back side seams. All other fabric and leather alternative applications will have concealed zippers in the outside back side seams.

When using a combination of fabrics or leathers, specify the application by designating the appropriate letter, shown below, on the purchase order. Yardage shown must be used.

See terms and conditions for contrasting upholstery upcharges.

- A) One fabric or leather for seat
 yardage: 1.75 yds. leather: 29.0 sq. ft.
- B) One fabric or leather for inside back and arms, outside back and sides, and front panel
 yardage: 4.25 yds. leather: 68.0 sq. ft.

SCS Indoor Advantage™ Gold and LEVEL® 2 certified. See terms and conditions for additional environmental information.

Seat Height	Arm Height	W	D	H	Fabric	Leather	Weight	Cubes/Qty
16¼"	-	30¾"	30"	28¾"	5.25 yds.	80.0'	64 lbs.	22.68'/1
413 mm	-	784 mm	762 mm	727 mm	4.8 m	7.4 sqm	29.0 kg	.64 cu.

COM	COL	1	2	3	4	5	6	7	8	9	10	11
2580	2685	3070	3152	3199	3292	3374	3409	3467	3549	3619	3700	4167

lily 3303

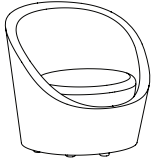

Fully upholstered

Casters

Felt and leather applications will have saddle stitch detail on the outside back side seams. All other fabric and leather alternative applications will have concealed zippers in the outside back side seams.

When using a combination of fabrics or leathers, specify the application by designating the appropriate letter, shown below, on the purchase order. Yardage shown must be used.

See terms and conditions for contrasting upholstery upcharges.

- A) One fabric or leather for seat
yardage: 1.75 yds. leather: 29.0 sq. ft.
- B) One fabric or leather for inside back and arms, outside back and sides, and front panel
yardage: 4.25 yds. leather: 68.0 sq. ft.

SCS Indoor Advantage™ Gold and LEVEL® 2 certified. See terms and conditions for additional environmental information.

Seat Height	Arm Height	W	D	H	Fabric	Leather	Weight	Cubes/Qty
16¾"	-	30¾"	30"	28¾"	5.25 yds.	80.0'	64 lbs.	22.68'/1
413 mm	-	784 mm	762 mm	727 mm	4.8 m	7.4 sqm	29.0 kg	.64 cu.

COM	COL	1	2	3	4	5	6	7	8	9	10	11
2738	2843	3228	3310	3357	3450	3532	3567	3625	3707	3777	3858	4325

lily 3304

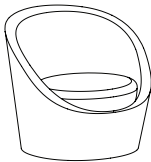

**Self-return swivel
Fully upholstered**

Felt and leather applications will have saddle stitch detail on the outside back side seams. All other fabric and leather alternative applications will have concealed zippers in the outside back side seams.

When using a combination of fabrics or leathers, specify the application by designating the appropriate letter, shown below, on the purchase order. Yardage shown must be used.

See terms and conditions for contrasting upholstery upcharges.

- A) One fabric or leather for seat
yardage: 1.75 yds. leather: 29.0 sq. ft.
- B) One fabric or leather for inside back and arms, outside back and sides, and front panel
yardage: 4.25 yds. leather: 68.0 sq. ft.

SCS Indoor Advantage™ Gold and LEVEL® 2 certified. See terms and conditions for additional environmental information.

Seat Height	Arm Height	W	D	H	Fabric	Leather	Weight	Cubes/Qty
16¾"	-	30¾"	30"	28¾"	5.25 yds.	80.0'	76 lbs.	22.68'/1
416 mm	-	784 mm	762 mm	730 mm	4.8 m	7.4 sqm	34.5 kg	.64 cu.

COM	COL	1	2	3	4	5	6	7	8	9	10	11
2970	3075	3460	3542	3589	3682	3764	3799	3857	3939	4009	4090	4557

lilypad 3306RB

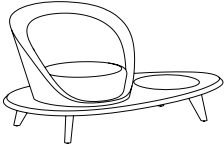

**Self-return swivel
Left lounge facing
Walnut platform
Silestone® insert
Upholstered Seat**

Upholstered seat installed on a 7" h solid walnut platform with bevel edge.

A 16" diameter, 3/4" h Silestone® insert in Lagoon (light grey) rests flush with platform

Upholstered seat dimensions: Seat Width 30 7/8" - 784 mm, Seat Depth 29 7/8" - 759 mm

Available in all walnut finishes except for LV8. When specifying light finishes the natural characteristics of the wood will be visible and color will vary.

Glides for hardsurface flooring are available by special request.

When using a combination of fabrics or leathers, specify the application by designating the appropriate letter, shown below, on the purchase order. Yardage shown must be used.

See terms and conditions for contrasting upholstery upcharges.

- A) One fabric or leather for seat
yardage: 1.75 yds. leather: 29.0 sq. ft.
- B) One fabric or leather for inside back, outside back and sides, inside arms and front panel
yardage: 4.25 yds. leather: 68.0 sq. ft.

See terms and conditions for additional finish information.

Seat Height	Arm Height	W	D	H	Fabric	Leather	Weight	Cubes/Qty
16"	-	60"	33"	29"	4.75 yds.	80.0'	132 lbs.	68.33'/1
406 mm	-	1524 mm	838 mm	737 mm	4.3 m	7.4 sqm	59.9 kg	1.93 cu.

COM	COL	1	2	3	4	5	6	7	8	9	10	11
5937	6032	6381	6455	6497	6581	6655	6687	6740	6814	6877	6951	7373

lilypad 3307LB

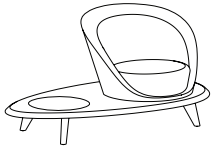

**Self-return Swivel
Right lounge facing
Walnut platform
Silestone® insert
Upholstered seat**

Upholstered seat installed on a 7" h solid walnut platform with bevel edge. A 16" diameter, ¾" h Silestone® insert in lagoon (light grey) rests flush with platform.

Upholstered seat dimensions: Seat Width 30¾" - 784 mm, Seat Depth 29¾" - 759 mm

Available in all walnut finishes except for LV8. When specifying light finishes the natural characteristics of the wood will be visible and color will vary.

Glides for hardsurface flooring are available by special request.

When using a combination of fabrics or leathers, specify the application by designating the appropriate letter, shown below, on the purchase order. Yardage shown must be used.

See terms and conditions for contrasting upholstery and welt upcharges.

- A) One fabric or leather for seat
yardage: 1.75 yds. leather: 29.0 sq. ft.
- B) One fabric or leather for inside back, outside back and sides, inside arms and front panel
yardage: 4.25 yds. leather: 68.0 sq. ft.

See terms and conditions for additional finish information.

Seat Height	Arm Height	W	D	H	Fabric	Leather	Weight	Cubes/Qty
16"	-	60"	33"	29"	4.75 yds.	80.0'	132 lbs.	68.33'/1
406 mm	-	1524 mm	838 mm	737 mm	4.3 m	7.4 sqm	59.9 kg	1.93 cu.

COM	COL	1	2	3	4	5	6	7	8	9	10	11
5937	6032	6381	6455	6497	6581	6655	6687	6740	6814	6877	6951	7373

loft 2401



**Solid walnut
Available in natural oiled LV8 finish only**

Seat Height	Arm Height	W	D	H	Fabric	Leather	Weight	Cubes/Qty
15"	-	27½"	29½"	27¾"	-	-	47 lbs.	36.09'/1
381 mm	-	699 mm	745 mm	705 mm	-	-	21.3 kg	1.04 cu.

List Price
3942

mellow

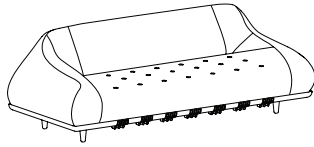

Upholstered

**Three-seat
Natural maple finish base and buttons**

- 5047 Red Fabric. White Cam Cleats. Natural Nylon Cord.**
- 5048 Black Fabric. Black Cam Cleats. Black Nylon Cord**

**Three-seat
Black maple finish base and buttons**

- 5049 Black fabric, Black cam cleats, Black nylon cord**
- 5050 Taupe fabric, Black cam cleats, Black nylon cord**

Memory foam seat. Natural or black nylon cord attaches to buttons in the seat which can be adjusted to modify the seat tufting. Grooves in the base and self-locking cam cleats hold the nylon cord in place. Maple base and buttons in natural maple (NAT) or black (BLK) finishes exclusive to Mellow.

Available in Bernhardt Textiles Red Océane fabric 3491-006, Black Océane fabric 3491-001 or Taupe Océane fabric 3491-002. Available only in the fabric and finish combinations noted. List price includes fabric.

SCS Indoor Advantage™ Gold and LEVEL® 2 certified. See terms and conditions for additional environmental information.

Seat Height	Arm Height	W	D	H	Fabric	Leather	Weight	Cubes/Qty
16 ⁵ / ₈ "	-	87 ¹ / ₂ "	38 ³ / ₈ "	30 ⁵ / ₈ "	-	-	250 lbs.	100.22'
422 mm	-	2223 mm	987 mm	778 mm	-	-	113.4 kg	2.8 cu.

COM
13675

mirador modular lounge

8010 - 8045 Mirador Modular Lounge

Mirador: Modular seating collection comprised of 63 unique modules, which may be used interchangeably to create an unlimited number of configurations.

For complete information reference Mirador in the lounge/modular section of the price list.

mitt 5720



**Mobile chair
Fully upholstered
Standard stitch with handle**

Standard stitch with handle
Four weight-activated self-locking casters

Handle is the same fabric or leather as the chair. Yardage for the handle is included in yardage requirements.

The contrasting handle is a different fabric or leather than the chair. For contrasting handle, the following yardage must be used and upcharges apply. Specify the fabric or leather application by designating the appropriate letter on the purchase order. Yardage shown must be used.

See terms and conditions for contrasting upholstery upcharges.

- A) One fabric or leather for chair
yardage: 4.5 yds. leather: 57 sq. ft.
- C) One fabric or leather for 1 - 5 handles
yardage: 1.0 yds. leather: 20 sq. ft.

SCS Indoor Advantage™ Gold and LEVEL® 2 certified. See terms and conditions for additional environmental information.

Seat Height	Arm Height	W	D	H	Fabric	Leather	Weight	Cubes/Qty
16½"	-	33½"	33½"	32"	4.5 yds.	57.0'	64 lbs.	36.09/1
419 mm	-	851 mm	851 mm	813 mm	4.1 m	5.3 sqm	29.0 kg	1.04 cu.

COM	COL	1	2	3	4	5	6	7	8	9	10	11
2848	2938	3268	3338	3378	3458	3528	3558	3608	3678	3738	3808	4208

mitt 5720L



**Mobile chair
Fully upholstered**

Loop master stitch with handle
Four weight-activated self-locking casters

Loop Master Stitch Specification: The thread color must be specified. Reference Mitt/Stitching on bernhardtdesign.com for color options. The same thread color will be used for the chair and handle.

Standard handle is the same fabric or leather as the chair. Yardage for the handle is included in yardage requirements.

The contrasting handle is a different fabric or leather than the chair. For contrasting handle, the following yardage must be used. Specify the fabric or leather application by designating the appropriate letter on the purchase order. Yardage shown must be used.

See terms and conditions for contrasting upholstery upcharges.

- A) One fabric or leather for chair
yardage: 4.5 yds. leather: 57 sq. ft.
- C) One fabric or leather for 1 - 5 handles
yardage: 1.0 yds. leather: 20 sq. ft.

SCS Indoor Advantage™ Gold and LEVEL® 2 certified. See terms and conditions for additional environmental information.

Seat Height	Arm Height	W	D	H	Fabric	Leather	Weight	Cubes/Qty
16½"	-	33½"	33½"	32"	4.5 yds.	57.0'	64 lbs.	36.09/1
419 mm	-	851 mm	851 mm	813 mm	4.1 m	5.3 sqm	29.0 kg	1.04 cu.

COM	COL	1	2	3	4	5	6	7	8	9	10	11
3204	3294	3624	3694	3734	3814	3884	3914	3964	4034	4094	4164	4564

mitt 5721



**Mobile chair
Fully upholstered**

Standard stitch
Four weight-activated self-locking casters

SCS Indoor Advantage™ Gold and LEVEL® 2 certified. See terms and conditions for additional environmental information.

Seat Height	Arm Height	W	D	H	Fabric	Leather	Weight	Cubes/Qty
16½"	-	33½"	33½"	32"	4.5 yds.	57.0'	64 lbs.	36.09/1
419 mm	-	851 mm	851 mm	813 mm	4.1 m	5.3 sqm	29.0 kg	1.04 cu.

COM	COL	1	2	3	4	5	6	7	8	9	10	11
2585	2675	3005	3075	3115	3195	3265	3295	3345	3415	3475	3545	3945

mitt 5721L



**Mobile chair
Fully upholstered**

Loop master stitched
Four weight-activated self-locking casters

Loop Master Stitch Specifications: Thread color must be specified. Reference Mitt/Stitching on bernhardtdesign.com for color options.

SCS Indoor Advantage™ Gold and LEVEL® 2 certified. See terms and conditions for additional environmental information.

Seat Height	Arm Height	W	D	H	Fabric	Leather	Weight	Cubes/Qty
16½"	-	33½"	33½"	32"	4.5 yds.	57.0'	64 lbs.	36.09/1
419 mm	-	851 mm	851 mm	813 mm	4.1 m	5.3 sqm	29.0 kg	1.04 cu.

COM	COL	1	2	3	4	5	6	7	8	9	10	11
2936	3026	3356	3426	3466	3546	3616	3646	3696	3766	3826	3896	4296

neighborhood modular lounge 6019 - 6049 Neighborhood Modular Lounge

Neighborhood : Modular seating and table collection comprised of 39 thirty-nine unique modules used interchangeably within a category to create an unlimited number of configurations.

For complete information reference Neighborhood in the lounge/modular section of the price list.

nico 8255



**Self-return swivel
Fully upholstered**

Inside seat width: 26¼", Inside seat depth: 22¼"

When using a combination of fabrics or leathers, specify the application by designating the appropriate letter, shown below, on the purchase order. Yardage shown must be used.

See terms and conditions for contrasting upholstery and welt upcharges.

- A) One fabric or leather for inside back and seat
yardage: 2.75 yds. leather: 45.0 sq. ft.
- B) One fabric or leather for outside back
yardage: 2.0 yds. leather: 33.0 sq. ft.
- C) One fabric or leather for outside seat
yardage: 2.0 yds. leather: 33.0 sq. ft.

Fabric must be railroaded. Certain stripes, plaids or fabrics with little stretch are not suitable for this product.

SCS Indoor Advantage® Gold and LEVEL® 2 certified. See terms and conditions for additional environmental information.

Seat Height	Arm Height	W	D	H	Fabric	Leather	Weight	Cubes/Qty
17½"	25¼"	35¼"	32½"	31"	6.75 yds	111.0'	95 lbs.	36.09/1
435 mm	654 mm	897 mm	814 mm	787 mm	6.2 m	10.3 sqm	43.1 kg.	1.02 cu.

COM	COL	1	2	3	4	5	6	7	8	9	10	11
4184	4319	4814	4919	4979	5099	5204	5249	5324	5429	5519	5624	6224

oslo 2405

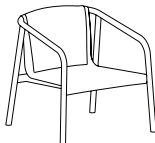

**Solid walnut frame
Upholstered
Back cushion**

Back cushion connects with two buttons

Available in all walnut finishes. When specifying light finishes the natural characteristics of the wood will be visible and color will vary.

When using a combination of fabrics or leathers, specify the application by designating the appropriate letter, shown below, on the purchase order. Yardage shown must be used.

See terms and conditions for contrasting upholstery upcharges.

- A) One fabric or leather for seat body
yardage: 2.0 yds. leather: 25.0 sq. ft.
- B) One fabric or leather for back cushion:
yardage: 1.0 yds. leather: 15.0 sq. ft.
- C) One fabric or leather for 2 buttons
yardage: .25 yds. leather: .5 sq. ft.

SCS Indoor Advantage™ Gold and LEVEL® 2 certified. See terms and conditions for additional finish and environmental information.

Seat Height	Arm Height	W	D	H	Fabric	Leather	Weight	Cubes/Qty
15½"	24¼"	28½"	28"	28¾"	3.0 yds.	45.0'	38 lbs.	22.69/1
394 mm	616 mm	724 mm	711 mm	730 mm	2.7 m	4.2 sqm	17.3 kg	.64 cu.

COM	COL	1	2	3	4	5	6	7	8	9	10	11
3378	3438	3658	3705	3732	3785	3832	3852	3885	3932	3972	4018	4285

oslo.02 2405A

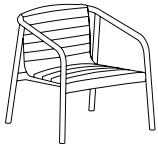

**Solid walnut frame
Upholstered
Channeled, quilted pad**

Available in all walnut finishes. When specifying light finishes the natural characteristics of the wood will be visible and color will vary.

When using a combination of fabrics or leathers, specify the application by designating the appropriate letter, shown below, on the purchase order. Yardage shown must be used.

See terms and conditions for contrasting upholstery upcharges.

- A) One fabric or leather for seat body
yardage: 2.0 yds. leather: 25.0 sq. ft.
- B) One fabric or leather for channeled, quilted pad
yardage: 1.5 yds. leather: 24.0 sq. ft.

SCS Indoor Advantage™ Gold and LEVEL® 2 certified. See terms and conditions for additional finish and environmental information.

Seat Height	Arm Height	W	D	H	Fabric	Leather	Weight	Cubes/Qty
16½"	24¼"	28½"	28"	28¾"	3.0 yds.	45.0'	38 lbs.	22.69'/1
419 mm	616 mm	724 mm	711 mm	730 mm	2.7 m	4.2 sqm	17.3 kg	.64 cu.

COM	COL	1	2	3	4	5	6	7	8	9	10	11
3378	3438	3658	3705	3732	3785	3832	3852	3885	3932	3972	4018	4285

prelude 5604



**Stationary chair
Fully upholstered**

Inside seat width: 27¼" Inside seat depth: 22½"

When using a combination of fabrics or leathers, specify the application by designating the appropriate letter, shown below, on the purchase order. Yardage shown must be used.

See terms and conditions for contrasting upholstery and welt upcharges.

- A) One fabric or leather for seat
yardage: 2.75 yds. leather: 44.0 sq. ft.
- B) One fabric or leather for inside and outside back
yardage: 4.1 yds. leather: 66.0 sq. ft.

SCS Indoor Advantage™ Gold and LEVEL® 2 certified. See terms and conditions for additional environmental information.

Seat Height	Arm Height	W	D	H	Fabric	Leather	Weight	Cubes/Qty
17¾"	23"	35"	31¼"	32¾"	6.85 yds	110.0'	100 lbs	37.96'/1
441 mm	584 mm	889 mm	794 mm	835 mm	6.3 m	10.2 sqm	45.4 kg	1.07 cu

COM	COL	1	2	3	4	5	6	7	8	9	10	11
2700	2837	3340	3446	3507	3629	3736	3781	3857	3964	4055	4162	4771

prelude 5605



**Swivel chair
Fully upholstered**

Inside seat width: 27¼" Inside seat depth: 22½"

When using a combination of fabrics or leathers, specify the application by designating the appropriate letter, shown below, on the purchase order. Yardage shown must be used.

See terms and conditions for contrasting upholstery and welt upcharges.

- A) One fabric or leather for seat
yardage: 2.75 yds. leather: 44.0 sq. ft.
- B) One fabric or leather for inside and outside back
yardage: 4.1 yds. leather: 66.0 sq. ft.

SCS Indoor Advantage™ Gold and LEVEL® 2 certified. See terms and conditions for additional environmental information.

Seat Height	Arm Height	W	D	H	Fabric	Leather	Weight	Cubes/Qty
17¾"	23"	35"	31¼"	32¾"	6.85 yds	110.0'	100 lbs	37.96/1
441 mm	584 mm	889 mm	794 mm	835 mm	6.3 m	10.2 sqm	45.4 kg	1.07 cu

COM	COL	1	2	3	4	5	6	7	8	9	10	11
3000	3137	3640	3746	3807	3929	4036	4081	4157	4264	4355	4462	5071

prelude 5606



**High back stationary chair
Fully upholstered**

Non-marring glides

Inside seat width: 26", Inside seat depth: 23"

When using a combination of fabrics or leathers, specify the application by designating the appropriate letter, shown below, on the purchase order. Yardage shown must be used.

See terms and conditions for contrasting upholstery upcharges.

- A) One fabric or leather for seat
yardage: 2.75 yds. leather: 44.0 sq. ft.
- B) One fabric or leather for back
yardage: 4.5 yds. leather: 73.0 sq. ft.

SCS Indoor Advantage™ Gold certified. See terms and conditions for additional environmental information.

Seat Height	Arm Height	W	D	H	Fabric	Leather	Weight	Cubes/Qty
17¾"	23"	35"	34"	38"	7.25 yds	118.0'	107 lbs	37.96/1
451 mm	584 mm	889 mm	876 mm	965 mm	6.3 m	10.2 sqm	48.5 kg	1.07 cu.

COM	COL	1	2	3	4	5	6	7	8	9	10	11
2800	2945	3477	3590	3654	3783	3896	3944	4025	4138	4234	4347	4992

prelude 5607

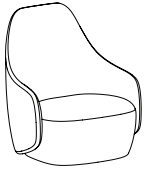

**High back self-return swivel
Fully upholstered**

Inside seat width: 26", Inside seat depth: 23"

When using a combination of fabrics or leathers, specify the application by designating the appropriate letter, shown below, on the purchase order. Yardage shown must be used.

See terms and conditions for contrasting upholstery upcharges.

- A) One fabric or leather for seat
yardage: 2.75 yds. leather: 44.0 sq. ft.
- B) One fabric or leather for back
yardage: 4.5 yds. leather: 73.0 sq. ft.

SCS Indoor Advantage™ Gold certified. See terms and conditions for additional environmental information.

Seat Height	Arm Height	W	D	H	Fabric	Leather	Weight	Cubes/Qty
17¼"	23"	35"	34"	38"	7.25 yds	118.0'	113 lbs	37.96/1
451 mm	584 mm	889 mm	876 mm	965 mm	6.3 m	10.2 sqm	51.2 kg	1.07 cu.

COM	COL	1	2	3	4	5	6	7	8	9	10	11
3100	3245	3777	3890	3954	4083	4196	4244	4325	4438	4534	4647	5292

ravel 6170A

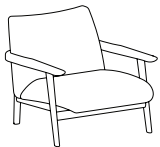

**Solid ash frame
Upholstered**

Available in all ash finishes. When specifying light finishes the natural characteristics of the wood will be visible and color will vary.

All COM/COL fabrics must be preapproved by Bernhardt Design prior to application.

SCS Indoor Advantage™ Gold and LEVEL® 2 certified. See terms and conditions for additional environmental information

Seat Height	Arm Height	W	D	H	Fabric	Leather	Weight	Cubes/Qty
17¼"	21¼"	35"	34"	30½"	4.25 yds.	69.0'	83 lbs.	36.09/1
439 mm	553 mm	889 mm	864 mm	778 mm	3.9 m	6.5 sqm	37.7 kg	1.03 cu.

COM	COL	1	2	3	4	5	6	7	8	9	10	11
3678	3763	4075	4141	4179	4255	4321	4349	4396	4462	4519	4585	4963

ravel 6170W

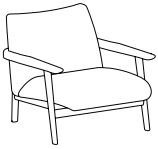

**Solid walnut frame
Upholstered**

Available in all walnut finishes. When specifying light finishes the natural characteristics of the wood will be visible and color will vary.

All COM/COL fabrics must be preapproved by Bernhardt Design prior to application.

SCS Indoor Advantage™ Gold and LEVEL® 2 certified. See terms and conditions for additional environmental information

Seat Height	Arm Height	W	D	H	Fabric	Leather	Weight	Cubes/Qty
17¼"	21¼"	35"	34"	30½"	4.25 yds.	69.0'	83 lbs.	36.09/1
439 mm	553 mm	889 mm	864 mm	778 mm	3.9 m	6.5 sqm	37.7 kg	1.03 cu.

COM	COL	1	2	3	4	5	6	7	8	9	10	11
4219	4304	4616	4682	4720	4796	4862	4890	4937	5003	5060	5126	5504

ravel 6177A

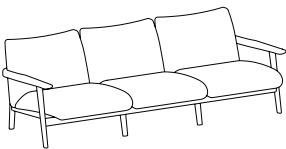

**Solid ash frame
Upholstered**

Available in all ash finishes. When specifying light finishes the natural characteristics of the wood will be visible and color will vary.

All COM/COL fabrics must be preapproved by Bernhardt Design prior to application.

SCS Indoor Advantage™ Gold and LEVEL® 2 certified. See terms and conditions for additional environmental information

Seat Height	Arm Height	W	D	H	Fabric	Leather	Weight	Cubes/Qty
17 ¼"	21¼"	98"	34"	30½"	11.75 yds.	191.0'	225 lbs.	101.65/1
553 mm	439 mm	2490 mm	864 mm	778 mm	10.75 m	17.8 sqm	102.0 kg	2.88 cu.

COM	COL	1	2	3	4	5	6	7	8	9	10	11
8545	8780	9642	9825	9929	10138	10321	10399	10530	10713	10869	11052	12097

ravel 6177W

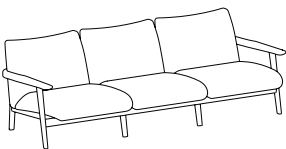

**Solid walnut frame
Upholstered**

Available in all walnut finishes. When specifying light finishes the natural characteristics of the wood will be visible and color will vary.

All COM/COL fabrics must be preapproved by Bernhardt Design prior to application.

SCS Indoor Advantage™ Gold and LEVEL® 2 certified. See terms and conditions for additional environmental information

Seat Height	Arm Height	W	D	H	Fabric	Leather	Weight	Cubes/Qty
17¼"	21¼"	98"	34"	30½"	11.75 yds.	191.0'	225 lbs.	101.65/1
439 mm	553 mm	2490 mm	864 mm	778 mm	10.75 m	17.8 sqm	102.0 kg	2.88 cu.

COM	COL	1	2	3	4	5	6	7	8	9	10	11
9627	9862	10724	10907	11011	11220	11403	11481	11612	11795	11951	12134	13179

rkc 3305



**Lounge chair
Polished aluminum or powder coat base
Upholstered**

Gray non-marring glides

Inside seat width: 30" Inside seat depth: 23¾"

When using a combination of fabrics or leathers, specify the application by designating the appropriate letter, shown below, on the purchase order. Yardage shown must be used.

See terms and conditions for contrasting upholstery upcharges.

- A) One fabric or leather for seat
yardage: 1.5 yds. leather: 20.25 sq. ft.
- B) One fabric or leather for inside and outside back
yardage: 4.0 yds. leather: 54.0 sq. ft.

SCS Indoor Advantage™ Gold and LEVEL® 2 certified. See terms and conditions for additional environmental information.

Seat Height	Arm Height	W	D	H	Fabric	Leather	Weight	Cubes/Qty
17¼"	-	34½"	33¾"	40"	5.5 yds	74.25'	100 lbs	46.29/1
438 mm	-	870 mm	857 mm	1016 mm	5.02 m	6.9 sqm	45.4 kg	1.31 cu

COM	COL	1	2	3	4	5	6	7	8	9	10	11
3245	3355	3759	3844	3893	3991	4077	4113	4174	4260	4333	4419	4908

sku

3	3	0	5	

base finish

- PA** polished aluminum standard, OR
- specify powder coat, upcharge \$150
- WH** satin white **GR** graphite **SG** sage green
- EC** ecru **BZ** bronze **RD** black red
- LA** latte **IG** iron grey **BK** matte black

vika 4700



**Self-return swivel
Polished stainless steel 4-star base
Upholstered seat and back**

When using a combination of fabrics or leathers, specify the application by designating the appropriate letter, shown below, on the purchase order. Yardage shown must be used.

See terms and conditions for contrasting fabric upcharges.

- A) One fabric or leather for inner seat
yardage: 2.25 yds. leather: 30.0 sq. ft.
- B) One fabric or leather for outer shell
yardage: 2.25 yds. leather: 30.0 sq. ft.

SCS Indoor Advantage™ Gold and LEVEL® 2 certified. See terms and conditions for additional finish and environmental information.

Seat Height	Arm Height	W	D	H	Fabric	Leather	Weight	Cubes/Qty
13¾"	-	33"	33¾"	34"	4.1 yds.	60.0'	73 lbs.	36.09/1
352 mm	-	838 mm	848 mm	864 mm	3.7 m	5.6 sqm	33.1 kg	1.04 cu.

COM	COL	1	2	3	4	5	6	7	8	9	10	11
4933	5015	5316	5380	5416	5489	5553	5580	5626	5690	5744	5808	6173

Alloro Seating System Specification Guide

Standard Features



Alloro is a modular seating system comprised of 35 unique modules which can be used interchangeably to create an unlimited number of configurations. Options include sofas or modular sectionals along with straight and flared fronts.

Alloro backs are constructed of fiberglass and come standard with an attached back cushion. Alloro modules are available with contrasting fabric options, please see pricing pages for details.

Alloro is fully upholstered with 2 $\frac{1}{4}$ " diameter non-marring adjustable glide. When ordering configurations, please provide the total COM yardage from the same dye lot in a continuous roll(s). All COM/COL fabrics must be preapproved by Bernhardt Design prior to application.

Configurations are connected by a ganging bracket. Ganging brackets are included with each module.

Alloro is SCS Indoor Advantage™ Gold and LEVEL® 2 certified. See terms and conditions for additional environmental information.

Please visit Bernhardtdesign.com for a complete library of 2D, 3D, and Revit models. You may also contact your local sales representative or the Bernhardt Design Corporate office for specification assistance.

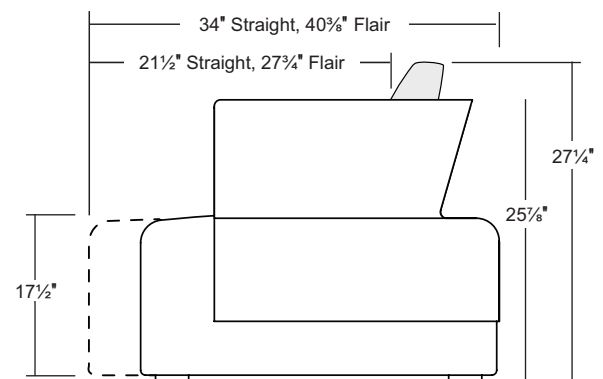

Side view of sku 4F37SX
2 $\frac{1}{4}$ " Diameter Non-Marring Adjustable Nylon Glides

Alloro Connecting

Alloro modular units connect together either on the end, on both sides or on the corner. The price list uses grey areas within the product illustrations to indicate the connecting areas of each unit. To the right is a sample illustration indicating the connecting areas for the products shown.

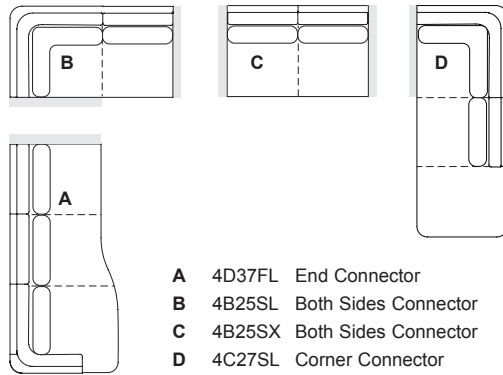

- A 4D37FL End Connector
- B 4B25SL Both Sides Connector
- C 4B25SX Both Sides Connector
- D 4C27SL Corner Connector

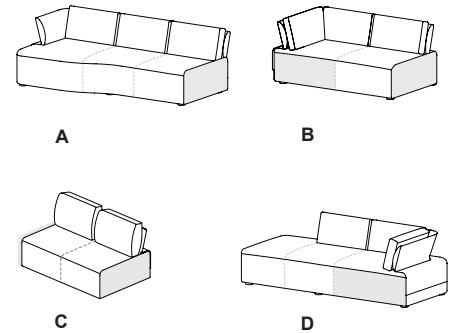

Alloro Seating System Sample Configurations

		Sku	Description
1		<p>4D37FL Three-seat End Connector. Left Arm Facing. Flared Front.</p> <p>4C27SL Three-seat Corner Connector. Left Arm Facing. Straight Front.</p>	
2		<p>4D37SL Three-seat End Connector. Left Arm Facing. Straight Front.</p> <p>4C27SL Three-seat Corner Connector. Left Arm Facing. Straight Front.</p>	
3		<p>4D37FL Three-seat End Connector. Left Arm Facing. Flared Front.</p> <p>4B25SL Two-seat Connector. Left Arm Facing. Straight Front.</p> <p>4D37FR Three-seat End Connector. Right Arm Facing. Flared Front.</p>	
4		<p>4D37SL Three-seat End Connector. Left Arm Facing. Straight Front.</p> <p>4D37SR Three-seat End Connector. Right Arm Facing. Straight Front.</p>	

alloro 4F25SX

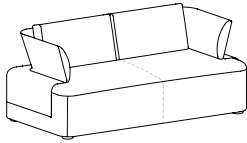

**Two-seat freestanding
Straight front module
Fully upholstered**

Two back cushions

Inside seat width: 52½", Inside seat depth: 21½"

When using a combination of fabrics or leathers, specify the application by designating the appropriate letter, shown below, on the purchase order. Yardage shown must be used.

See terms and conditions for contrasting upholstery upcharges.

- A) One fabric or leather for seat
yardage: 4.5 yds. leather: 73.0 sq. ft.
- B) One fabric or leather for back
yardage: 6.5 yds. leather: 106.0 sq. ft.
- C) One fabric or leather for back cushion
yardage: 3.5 yds. leather: 57.0 sq. ft.

SCS Indoor Advantage™ Gold and LEVEL® 2 certified. See terms and conditions for additional environmental information.

Seat Height	Arm Height	W	D	H	Fabric	Leather	Weight	Cubes/Qty
17½"	11"	66½"	34"	27¼"	14.5 yds.	236.0'	205 lbs.	56.06'/1
445 mm	280 mm	1690 mm	864 mm	690 mm	13.3 m	22.0 sqm	93.0 kg	1.6 cu

COM	COL	1	2	3	4	5	6	7	8	9	10	11
7464	7754	8818	9043	9172	9430	9656	9752	9913	10139	10332	10558	11847

alloro 4F37SX

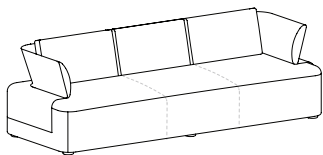

**Three-seat freestanding
Straight front module
Fully upholstered**

Three back cushions

Inside seat width: 52½", Inside seat depth: 21½"

When using a combination of fabrics or leathers, specify the application by designating the appropriate letter, shown below, on the purchase order. Yardage shown must be used.

See terms and conditions for contrasting upholstery upcharges.

- A) One fabric or leather for seat
yardage: 6.5 yds. leather: 106.0 sq. ft.
- B) One fabric or leather for back
yardage: 8.0 yds. leather: 130.0 sq. ft.
- C) One fabric or leather for back cushion
yardage: 5.5 yds. leather: 85.0 sq. ft.

SCS Indoor Advantage™ Gold and LEVEL® 2 certified. See terms and conditions for additional environmental information.

Seat Height	Arm Height	W	D	H	Fabric	Leather	Weight	Cubes/Qty
17½"	11"	93⅞"	34"	27¼"	20.0 yds.	321.0'	290 lbs.	89.84'/1
445 mm	280 mm	2340 mm	864 mm	690 mm	18.3 m	30.0 sqm	132 kg	2.5 cu

COM	COL	1	2	3	4	5	6	7	8	9	10	11
8761	9161	10628	10939	11117	11473	11784	11917	12139	12450	12717	13028	14806

alloro 4F37FL

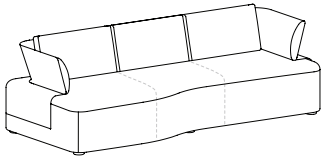

**Three-seat freestanding
Left side flared front module
Fully upholstered**

Three back cushions

Inside seat width: 78¾", Inside seat depth: 27¾"

When using a combination of fabrics or leathers, specify the application by designating the appropriate letter, shown below, on the purchase order. Yardage shown must be used.

See terms and conditions for contrasting upholstery upcharges.

- A) One fabric or leather for seat
yardage: 7.25 yds. leather: 118.0 sq. ft.
- B) One fabric or leather for back
yardage: 8.0 yds. leather: 130.0 sq. ft.
- C) One fabric or leather for back cushion
yardage: 5.5 yds. leather: 85.0 sq. ft.

SCS Indoor Advantage™ Gold and LEVEL® 2 certified. See terms and conditions for additional environmental information.

Seat Height	Arm Height	W	D	H	Fabric	Leather	Weight	Cubes/Qty
17½"	11"	93¾"	40¾"	27¾"	20.8 yds.	333.0'	295 lbs.	89.84/1
445 mm	280 mm	2340 mm	1026 mm	690 mm	19.0 m	31.0 sqm	133.8 kg	2.5 cu

COM	COL	1	2	3	4	5	6	7	8	9	10	11
8978	9394	10920	11243	11428	11798	12122	12260	12491	12815	13092	13416	15265

alloro 4F37FR

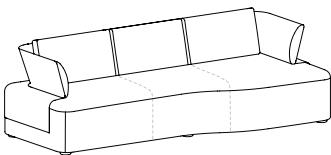

**Three-seat freestanding
Right side flared front module
Fully upholstered**

Three back cushions

Inside seat width: 78¾", Inside seat depth: 27¾"

When using a combination of fabrics or leathers, specify the application by designating the appropriate letter, shown below, on the purchase order. Yardage shown must be used.

See terms and conditions for contrasting upholstery upcharges.

- A) One fabric or leather for seat
yardage: 7.25 yds. leather: 118.0 sq. ft.
- B) One fabric or leather for back
yardage: 8.0 yds. leather: 130.0 sq. ft.
- C) One fabric or leather for back cushion
yardage: 5.5 yds. leather: 85.0 sq. ft.

SCS Indoor Advantage™ Gold and LEVEL® 2 certified. See terms and conditions for additional environmental information.

Seat Height	Arm Height	W	D	H	Fabric	Leather	Weight	Cubes/Qty
17½"	11"	93¾"	40¾"	27¾"	20.8 yds.	333.0'	295 lbs.	89.84/1
445 mm	280 mm	2340 mm	1026 mm	690 mm	19.0 m	31.0 sqm	133.8 kg	2.5 cu

COM	COL	1	2	3	4	5	6	7	8	9	10	11
8978	9394	10920	11243	11428	11798	12122	12260	12491	12815	13092	13416	15265

Freestanding modules

alloro

alloro 4F15SL

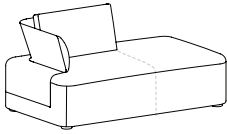

**Two-seat freestanding
Left arm facing open module
Straight front
Fully upholstered**

One back cushion

Inside seat width: 52½", Inside seat depth: 21½"

When using a combination of fabrics or leathers, specify the application by designating the appropriate letter, shown below, on the purchase order. Yardage shown must be used.

See terms and conditions for contrasting upholstery upcharges.

- A) One fabric or leather for seat
yardage: 4.5 yds. leather: 73.0 sq. ft.
- B) One fabric or leather for back
yardage: 3.5 yds. leather: 57.0 sq. ft.
- C) One fabric or leather for back cushion
yardage: 2.0 yds. leather: 31.0 sq. ft.

SCS Indoor Advantage™ Gold and LEVEL® 2 certified. See terms and conditions for additional environmental information.

Seat Height	Arm Height	W	D	H	Fabric	Leather	Weight	Cubes/Qty
17½"	11"	59½"	34"	27¼"	10.0 yds.	161.0'	203 lbs.	56.06'/1
445 mm	280 mm	1515 mm	864 mm	690 mm	9.2 m	15.0 sqm	92.1 kg	1.6 cu

COM	COL	1	2	3	4	5	6	7	8	9	10	11
5841	6041	6775	6930	7019	7197	7353	7419	7530	7686	7819	7975	8864

alloro 4F15SR

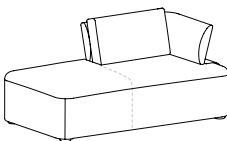

**Two-seat freestanding
Right arm facing open module
Straight front
Fully upholstered**

One back cushion

Inside seat width: 52½", Inside seat depth: 21½"

When using a combination of fabrics or leathers, specify the application by designating the appropriate letter, shown below, on the purchase order. Yardage shown must be used.

See terms and conditions for contrasting upholstery upcharges.

- A) One fabric or leather for seat
yardage: 4.5 yds. leather: 73.0 sq. ft.
- B) One fabric or leather for back
yardage: 3.5 yds. leather: 57.0 sq. ft.
- C) One fabric or leather for back cushion
yardage: 2.0 yds. leather: 31.0 sq. ft.

SCS Indoor Advantage™ Gold and LEVEL® 2 certified. See terms and conditions for additional environmental information.

Seat Height	Arm Height	W	H	D	Fabric	Leather	Weight	Cubes/Qty
17½"	11"	59½"	34"	27¼"	10.0 yds.	161.0'	203 lbs.	56.06'/1
445 mm	280 mm	1515 mm	864 mm	690 mm	9.2 m	15.0 sqm	92.1 kg	1.6 cu

COM	COL	1	2	3	4	5	6	7	8	9	10	11
5841	6041	6775	6930	7019	7197	7353	7419	7530	7686	7819	7975	8864

Freestanding modules

alloro

alloro 4F17SL

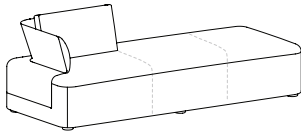

**Three-seat freestanding
Left arm facing open module
Straight front
Fully upholstered**

One back cushion

Inside seat width: 78¾", Inside seat depth: 21½"

When using a combination of fabrics or leathers, specify the application by designating the appropriate letter, shown below, on the purchase order. Yardage shown must be used.

See terms and conditions for contrasting upholstery upcharges.

- A) One fabric or leather for seat
yardage: 6.5 yds. leather: 106.0 sq. ft.
- B) One fabric or leather for back
yardage: 3.5 yds. leather: 57.0 sq. ft.
- C) One fabric or leather for back cushion
yardage: 2.0 yds. leather: 31.0 sq. ft.

SCS Indoor Advantage™ Gold and LEVEL® 2 certified. See terms and conditions for additional environmental information.

Seat Height	Arm Height	W	D	H	Fabric	Leather	Weight	Cubes/Qty
17½"	11"	86"	34"	27¼"	12.0 yds.	194.0'	257 lbs.	77.86'/1
445 mm	280 mm	2185 mm	864 mm	690 mm	11.0 m	18.0 sqm	116.6 kg	2.2 cu

COM	COL	1	2	3	4	5	6	7	8	9	10	11
6382	6622	7502	7689	7796	8009	8196	8276	8409	8596	8756	8942	10009

alloro 4F17SR

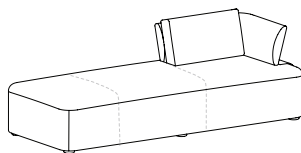

**Three-seat freestanding
Right arm facing open module
Straight front
Fully upholstered**

One back cushion

Inside seat width: 78¾", Inside seat depth: 21½"

When using a combination of fabrics or leathers, specify the application by designating the appropriate letter, shown below, on the purchase order. Yardage shown must be used.

See terms and conditions for contrasting upholstery upcharges.

- A) One fabric or leather for seat
yardage: 6.5 yds. leather: 106.0 sq. ft.
- B) One fabric or leather for back
yardage: 3.5 yds. leather: 57.0 sq. ft.
- C) One fabric or leather for back cushion
yardage: 2.0 yds. leather: 31.0 sq. ft.

SCS Indoor Advantage™ Gold and LEVEL® 2 certified. See terms and conditions for additional environmental information.

Seat Height	Arm Height	W	D	H	Fabric	Leather	Weight	Cubes/Qty
17½"	11"	86"	34"	27¼"	12.0 yds.	194.0'	257 lbs.	77.86'/1
445 mm	280 mm	2185 mm	864 mm	690 mm	11.0 m	18.0 sqm	116.6 kg	2.2 cu

COM	COL	1	2	3	4	5	6	7	8	9	10	11
6382	6622	7502	7689	7796	8009	8196	8276	8409	8596	8756	8942	10009

Freestanding modules

alloro

alloro 4F27SL

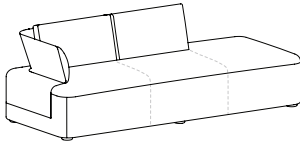

**Three-seat freestanding
Left arm facing open module
Straight front.
Fully upholstered**

Two back cushions

Inside seat width: 78¾", Inside seat depth: 21½"

When using a combination of fabrics or leathers, specify the application by designating the appropriate letter, shown below, on the purchase order. Yardage shown must be used.

See terms and conditions for contrasting upholstery upcharges.

- A) One fabric or leather for seat
yardage: 6.5 yds. leather: 106.0 sq. ft.
- B) One fabric or leather for back
yardage: 5.0 yds. leather: 81.0 sq. ft.
- C) One fabric or leather for back cushion
yardage: 3.5 yds. leather: 57.0 sq. ft.

SCS Indoor Advantage™ Gold and LEVEL® 2 certified. See terms and conditons for additional environmental information.

Seat Height	Arm Height	W	D	H	Fabric	Leather	Weight	Cubes/Qty
17½"	11"	86"	34"	27¼"	15.0 yds.	244.0'	257 lbs.	77.86'/1
445 mm	280 mm	2185 mm	864 mm	690 mm	14.0 m	23.0 sqm	116.6 kg	2.2 cu

COM	COL	1	2	3	4	5	6	7	8	9	10	11
7139	7439	8539	8773	8906	9173	9406	9506	9673	9906	10106	10339	11673

alloro 4F27SR

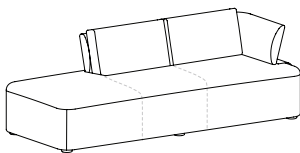

**Three-seat freestanding
Right arm facing open module
Straight front
Fully upholstered**

Two back cushions

Inside seat width: 78¾", Inside seat depth: 21½"

When using a combination of fabrics or leathers, specify the application by designating the appropriate letter, shown below, on the purchase order. Yardage shown must be used.

See terms and conditions for contrasting upholstery upcharges.

- A) One fabric or leather for seat
yardage: 6.5 yds. leather: 106.0 sq. ft.
- B) One fabric or leather for back
yardage: 5.0 yds. leather: 81.0 sq. ft.
- C) One fabric or leather for back cushion
yardage: 3.5 yds. leather: 57.0 sq. ft.

SCS Indoor Advantage™ Gold and LEVEL® 2 certified. See terms and conditons for additional environmental information.

Seat Height	Arm Height	W	D	H	Fabric	Leather	Weight	Cubes/Qty
17½"	11"	86"	34"	27¼"	15.0 yds.	244.0'	257 lbs.	77.86'/1
445 mm	280 mm	2185 mm	864 mm	690 mm	14.0 m	23.0 sqm	116.6 kg	2.2 cu

COM	COL	1	2	3	4	5	6	7	8	9	10	11
7139	7439	8539	8773	8906	9173	9406	9506	9673	9906	10106	10339	11673

Freestanding modules

alloro

alloro 4F17FL

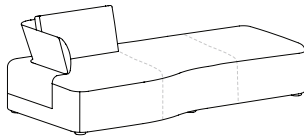

**Three-seat freestanding
Left arm facing open module
Left side flared front
Fully upholstered**

One back cushion

Inside seat width: 78¾", Inside seat depth: 27¾"

When using a combination of fabrics or leathers, specify the application by designating the appropriate letter, shown below, on the purchase order. Yardage shown must be used.

See terms and conditions for contrasting upholstery upcharges.

- A) One fabric or leather for seat
yardage: 7.0 yds. leather: 114.0 sq. ft.
- B) One fabric or leather for back
yardage: 3.5 yds. leather: 57.0 sq. ft.
- C) One fabric or leather for back cushion
yardage: 2.25 yds. leather: 36.0 sq. ft.

SCS Indoor Advantage™ Gold and LEVEL® 2 certified. See terms and conditions for additional environment information.

Seat Height	Arm Height	W	D	H	Fabric	Leather	Weight	Cubes/Qty
17½"	11"	92¾"	40¾"	27¾"	12.8 yds.	207.0'	295 lbs.	89.84'/1
445 mm	280 mm	2356 mm	1026 mm	690 mm	12.0 m	19.3 sqm	133.8 kg	2.5 cu

COM	COL	1	2	3	4	5	6	7	8	9	10	11
6598	6854	7793	7992	8106	8334	8533	8618	8760	8959	9130	9329	10467

alloro 4F17FR

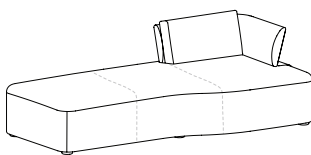

**Three-seat freestanding
Right arm facing open module
Right side flared front
Fully upholstered**

One back cushion

Inside seat width: 78¾", Inside seat depth: 27¾"

When using a combination of fabrics or leathers, specify the application by designating the appropriate letter, shown below, on the purchase order. Yardage shown must be used.

See terms and conditions for contrasting upholstery upcharges.

- A) One fabric or leather for seat
yardage: 7.0 yds. leather: 114.0 sq. ft.
- B) One fabric or leather for back
yardage: 3.5 yds. leather: 57.0 sq. ft.
- C) One fabric or leather for back cushion
yardage: 2.25 yds. leather: 36.0 sq. ft.

SCS Indoor Advantage™ Gold and LEVEL® 2 certified. See terms and conditions for additional environmental information.

Seat Height	Arm Height	W	D	H	Fabric	Leather	Weight	Cubes/Qty
17½"	11"	92¾"	40¾"	27¾"	12.8 yds.	207.0'	295 lbs.	89.84'/1
445 mm	280 mm	2356 mm	1026 mm	690 mm	12.0 m	19.3 sqm	133.8 kg	2.5 cu

COM	COL	1	2	3	4	5	6	7	8	9	10	11
6598	6854	7793	7992	8106	8334	8533	8618	8760	8959	9130	9329	10467

Freestanding modules

alloro

alloro 4F27FL

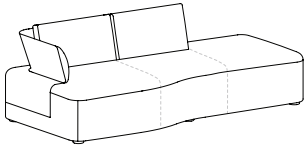

**Three-seat freestanding
Left arm facing open module
Left side flared front
Fully upholstered**

Two back cushions

Inside seat width: 78¾", Inside seat depth: 27¾"

When using a combination of fabrics or leathers, specify the application by designating the appropriate letter, shown below, on the purchase order. Yardage shown must be used.

See terms and conditions for contrasting upholstery upcharges.

- A) One fabric or leather for seat
yardage: 7.25 yds leather: 118.0 sq. ft.
- B) One fabric or leather for back
yardage: 5.5 yds. leather: 85.0 sq. ft.
- C) One fabric or leather for back cushion
yardage: 3.5 yds. leather: 57.0 sq. ft.

SCS Indoor Advantage™ Gold and LEVEL® 2 certified. See terms and conditions for additional environmental information.

Seat Height	Arm Height	W	D	H	Fabric	Leather	Weight	Cubes/Qty
17½"	11"	92¾"	40¾"	27¾"	16.3 yds.	260.0'	295 lbs.	89.84/1
445 mm	280 mm	2356 mm	1026 mm	690 mm	15.0 m	24.2 sqm	133.8 kg	2.5 cu

COM	COL	1	2	3	4	5	6	7	8	9	10	11
7355	7681	8877	9130	9275	9565	9819	9927	10108	10362	10579	10833	12282

alloro 4F27FR

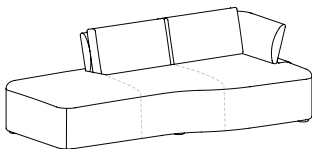

**Three-seat freestanding
Right arm facing open module
Right side flared front
Fully upholstered**

Two back cushions

Inside seat width: 78¾", Inside seat depth: 27¾"

When using a combination of fabrics or leathers, specify the application by designating the appropriate letter, shown below, on the purchase order. Yardage shown must be used.

See terms and conditions for contrasting upholstery upcharges.

- A) One fabric or leather for seat
yardage: 7.25 yds leather: 118.0 sq. ft.
- B) One fabric or leather for back
yardage: 5.5 yds. leather: 85.0 sq. ft.
- C) One fabric or leather for back cushion
yardage: 3.5 yds. leather: 57.0 sq. ft.

SCS Indoor Advantage™ Gold and LEVEL® 2 certified. See terms and conditions for additional environmental information.

Seat Height	Arm Height	W	D	H	Fabric	Leather	Weight	Cubes/Qty
17½"	11"	92¾"	40¾"	27¾"	16.3 yds.	260.0'	295 lb.s	89.84/1
445 mm	280 mm	2356 mm	1026 mm	690 mm	15.0 m	24.2 sqm	133.8 kg	2.5 cu

COM	COL	1	2	3	4	5	6	7	8	9	10	11
7355	7681	8877	9130	9275	9565	9819	9927	10108	10362	10579	10833	12282

alloro 4C15SL

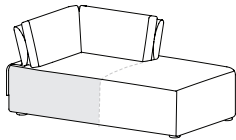

Two-seat corner connector
Left arm facing module
Straight front
Fully upholstered

One back cushion
 Ganging brackets included
 Freestanding option not available

Inside seat width: 52½", Inside seat depth: 21½"

When using a combination of fabrics or leathers, specify the application by designating the appropriate letter, shown below, on the purchase order. Yardage shown must be used.

See terms and conditions for contrasting upholstery upcharges..

- A) One fabric or leather for seat
 yardage: 4.5 yds. leather: 73.0 sq. ft.
- B) One fabric or leather for back
 yardage: 3.5 yds. leather: 57.0 sq. ft.
- C) One fabric or leather for back cushion
 yardage: 3.5 yds. leather: 57.0 sq. ft.

SCS Indoor Advantage™ Gold and LEVEL® 2 certified. See terms and conditions for additional environmental information.

Seat Height	Arm Height	W	D	H	Fabric	Leather	Weight	Cubes/Qty
17½"	11"	61¼"	34"	27¼"	11.5 yds.	187.0'	208 lbs.	56.06'/1
445 mm	280 mm	1556 mm	864 mm	690 mm	11.0 m	17.4 sqm	94.4 kg	1.6 cu

COM	COL	1	2	3	4	5	6	7	8	9	10	11
5625	5855	6699	6878	6980	7184	7363	7440	7568	7747	7900	8079	9101

alloro 4C15SR

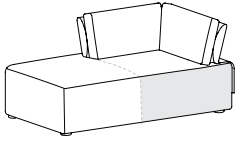

Two-seat corner connector
Right arm facing module
Straight front
Fully upholstered

One back cushion
 Ganging brackets included
 Freestanding option not available

Inside seat width: 52½", Inside seat depth: 21½"

When using a combination of fabrics or leathers, specify the application by designating the appropriate letter, shown below, on the purchase order. Yardage shown must be used.

See terms and conditions for contrasting upholstery upcharges.

- A) One fabric or leather for seat
 yardage: 4.5 yds. leather: 73.0 sq. ft.
- B) One fabric or leather for back
 yardage: 3.5 yds. leather: 57.0 sq. ft.
- C) One fabric or leather for back cushion
 yardage: 3.5 yds. leather: 57.0 sq. ft.

SCS Indoor Advantage™ Gold and LEVEL® 2 certified. See terms and conditions for additional environmental information.

Seat Height	Arm Height	W	D	H	Fabric	Leather	Weight	Cubes/Qty
17½"	11"	61¼"	34"	27¼"	11.5 yds.	187.0'	208 lbs.	56.06'/1
445 mm	280 mm	1556 mm	864 mm	690 mm	11.0 m	17.4 sqm	94.4 kg	1.6 cu

COM	COL	1	2	3	4	5	6	7	8	9	10	11
5625	5855	6699	6878	6980	7184	7363	7440	7568	7747	7900	8079	9101

alloro 4C17SL

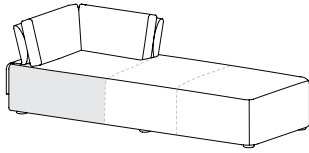

Three-seat corner connector
Left arm facing open module
Straight front
Fully upholstered

One back cushion
 Ganging brackets included
 Freestanding option not available

Inside seat width: 78¾", Inside seat depth: 21½"

When using a combination of fabrics or leathers, specify the application by designating the appropriate letter, shown below, on the purchase order. Yardage shown must be used.

See terms and conditions for contrasting upholstery upcharges.

- A) One fabric or leather for seat
 yardage: 6.5 yds leather: 110 sq. ft.
- B) One fabric or leather for back
 yardage: 3.5 yds. leather: 57.0 sq. ft.
- C) One fabric or leather for back cushion
 yardage: 3.5 yds. leather: 57.0 sq. ft.

SCS Indoor Advantage™ Gold and LEVEL® 2 certified. See terms and conditions for additional environmental information.

Seat Height	Arm Height	W	D	H	Fabric	Leather	Weight	Cubes/Qty
17½"	11"	86¾"	34"	27¼"	13.5 yds.	224.0'	290 lbs.	77.86'/1
445 mm	280 mm	2001 mm	864 mm	690 mm	12.4 m	20.9 sqm	132 kg	2.2 cu

COM	COL	1	2	3	4	5	6	7	8	9	10	11
6598	6868	7858	8068	8188	8428	8638	8728	8878	9088	9268	9478	10678

alloro 4C17SR

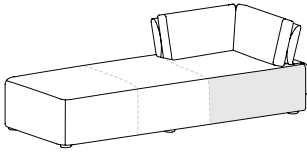

Three-seat corner connector
Right arm facing open module
Straight front
Fully upholstered

One back cushion
 Ganging brackets included
 Freestanding option not available

Inside seat width: 78¾", Inside seat depth: 21½"

When using a combination of fabrics or leathers, specify the application by designating the appropriate letter, shown below, on the purchase order. Yardage shown must be used.

See terms and conditions for contrasting upholstery upcharges.

- A) One fabric or leather for seat
 yardage: 6.5 yds leather: 110.0 sq. ft.
- B) One fabric or leather for back
 yardage: 3.5 yds. leather: 57.0 sq. ft.
- C) One fabric or leather for back cushion
 yardage: 3.5 yds. leather: 57.0 sq. ft.

SCS Indoor Advantage™ Gold and LEVEL® 2 certified. See terms and conditions for additional environmental information.

Seat Height	Arm Height	W	D	H	Fabric	Leather	Weight	Cubes/Qty
17½"	11"	86¾"	34"	27¼"	13.5 yds.	224.0'	290 lbs.	77.86'/1
445 mm	280 mm	2001 mm	864 mm	690 mm	12.4 m	20.9 sqm	132 kg	2.2 cu

COM	COL	1	2	3	4	5	6	7	8	9	10	11
6598	6868	7858	8068	8188	8428	8638	8728	8878	9088	9268	9478	10678

alloro 4C27SL

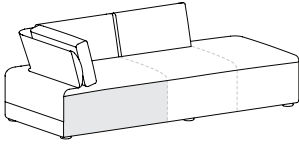

Three-seat corner connector
Left arm facing open module
Straight front
Fully upholstered

Two back cushions
 Ganging brackets included
 Freestanding option not available

Inside seat width: 78¾". Inside seat depth: 21½"

When using a combination of fabrics or leathers, specify the application by designating the appropriate letter, shown below, on the purchase order. Yardage shown must be used.

See terms and conditions for contrasting upholstery upcharges.

- A) One fabric or leather for seat.
 yardage: 6.5 yds. leather: 110.0 sq. ft.
- B) One fabric or leather for back.
 yardage: 5.0 yds. leather: 81.0 sq. ft.
- C) One fabric or leather for back cushion.
 yardage: 5.0 yds. leather: 81.0 sq. ft.

SCS Indoor Advantage™ Gold and LEVEL® 2 certified. See terms and conditions for additional environmental information.

Seat Height	Arm Height	W	D	H	Fabric	Leather	Weight	Cubes/Qty
17½"	11"	86¾"	34"	27¼"	16.5 yds.	272.0'	290 lbs.	77.86'/1
445 mm	280 mm	2001 mm	864 mm	690 mm	15.1 m	25.3 sqm	132 kg	2.2 cu

COM	COL	1	2	3	4	5	6	7	8	9	10	11
7355	7685	8895	9152	9299	9592	9849	9959	10142	10399	10619	10875	12342

alloro 4C27SR

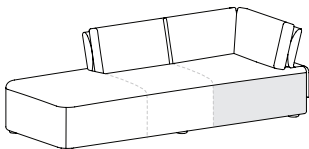

Three-seat corner connector
Right arm facing open module
Straight front
Fully upholstered

Two back cushions
 Ganging brackets included
 Freestanding option not available

Inside seat width: 78¾" Inside seat depth: 21½"

When using a combination of fabrics or leathers, specify the application by designating the appropriate letter, shown below, on the purchase order. Yardage shown must be used.

See terms and conditions for contrasting upholstery upcharges.

- A) One fabric or leather for seat.
 yardage: 6.5 yds. leather: 110.0 sq. ft.
- B) One fabric or leather for back.
 yardage: 5.0 yds. leather: 81.0 sq. ft.
- C) One fabric or leather for back cushion.
 yardage: 5.0 yds. leather: 81.0 sq. ft.

SCS Indoor Advantage™ Gold and LEVEL® 2 certified. See terms and conditions for additional environmental information.

Seat Height	Arm Height	W	D	H	Fabric	Leather	Weight	Cubes/Qty
17½"	11"	86¾"	34"	27¼"	16.5 yds.	272.0'	290 lbs.	77.86'/1
445 mm	280 mm	2001 mm	864 mm	690 mm	15.1 m	25.3 sqm	132 kg	2.2 cu

COM	COL	1	2	3	4	5	6	7	8	9	10	11
7355	7685	8895	9152	9299	9592	9849	9959	10142	10399	10619	10875	12342

alloro 4D25SL

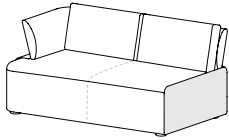

**Two-seat end connector
Left arm facing module
Straight front
Fully upholstered**

Two back cushions
Ganging brackets included
Freestanding option not available

Inside seat width: 52½", Inside seat depth: 21½"

When using a combination of fabrics or leathers, specify the application by designating the appropriate letter, shown below, on the purchase order. Yardage shown must be used.

See terms and conditions for contrasting upholstery upcharges.

- A) One fabric or leather for seat
yardage: 4.5 yds. leather: 73.0 sq. ft.
- B) One fabric or leather for back
yardage: 5.0 yds. leather: 81.0 sq. ft.
- C) One fabric or leather for back cushion
yardage: 3.5 yds. leather: 57.0 sq. ft.

SCS Indoor Advantage™ Gold and LEVEL® 2 certified. See terms and conditions for additional environmental information.

Seat Height	Arm Height	W	D	H	Fabric	Leather	Weight	Cubes/Qty
17½"	11"	61 ¼"	34"	27¼"	13.0 yds.	211.0'	208 lbs.	56.06'/1
445 mm	280 mm	1556 mm	864 mm	690 mm	12.0 m	20.0 sqm	94.4 kg	1.6 cu

COM	COL	1	2	3	4	5	6	7	8	9	10	11
6706	6966	7920	8122	8238	8469	8671	8758	8902	9104	9278	9480	10635

alloro 4D25SR

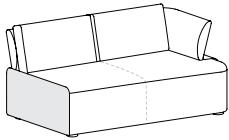

**Two-seat end connector
Right arm facing module
Straight front
Fully upholstered**

Two back cushions
Ganging brackets included
Freestanding option not available

Inside seat width: 52½", Inside seat depth: 21½"

When using a combination of fabrics or leathers, specify the application by designating the appropriate letter, shown below, on the purchase order. Yardage shown must be used.

See terms and conditions for contrasting upholstery upcharges.

- A) One fabric or leather for seat
yardage: 4.5 yds. leather: 73.0 sq. ft.
- B) One fabric or leather for back
yardage: 5.0 yds. leather: 81.0 sq. ft.
- C) One fabric or leather for back cushion
yardage: 3.5 yds. leather: 57.0 sq. ft.

SCS Indoor Advantage™ Gold and LEVEL® 2 certified. See terms and conditions for additional environmental information.

Seat Height	Arm Height	W	D	H	Fabric	Leather	Weight	Cubes/Qty
17½"	11"	61 ¼"	34"	27¼"	13 yds.	211.0'	208 lbs.	56.06'/1
445 mm	280 mm	1556 mm	864 mm	690 mm	12.0 m	20.0 sqm	94.4 kg	1.6 cu

COM	COL	1	2	3	4	5	6	7	8	9	10	11
6706	6966	7920	8122	8238	8469	8671	8758	8902	9104	9278	9480	10635

alloro 4D37SL

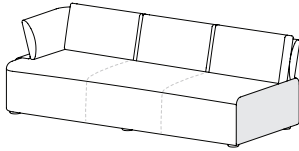

**Three-seat end connector
Left arm facing module
Straight front
Fully upholstered**

Three back cushions
Ganging brackets included
Freestanding option not available

Inside seat width: 78¾", Inside seat depth: 21½"

When using a combination of fabrics or leathers, specify the application by designating the appropriate letter, shown below, on the purchase order. Yardage shown must be used.

See terms and conditions for contrasting upholstery upcharges.

- A) One fabric or leather for seat
yardage: 6.5 yds. leather: 110.0 sq. ft.
- B) One fabric or leather for back
yardage: 6.5 yds. leather: 110.0 sq. ft.
- C) One fabric or leather for back cushion
yardage: 5.0 yds leather: 81.0 sq. ft.

SCS Indoor Advantage™ Gold and LEVEL® 2 certified. See terms and conditions for additional environmental information.

Seat Height	Arm Height	W	D	H	Fabric	Leather	Weight	Cubes/Qty
17½"	11"	86¾"	34"	27¼"	18.0 yds.	301.0'	290 lbs.	77.86'/1
445 mm	280 mm	2001 mm	864 mm	690 mm	16.5 m	28.0 sqm	132 kg	2.2 cu

COM	COL	1	2	3	4	5	6	7	8	9	10	11
8221	8581	9901	10181	10341	10661	10941	11061	11261	11541	11781	12061	13661

alloro 4D37SR

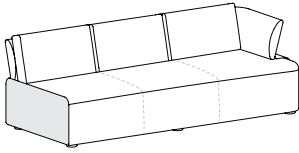

**Three-seat end connector
Right arm facing module
Straight front
Fully upholstered**

Three back cushions
Ganging brackets included
Freestanding option not available

Inside seat width: 78¾", Inside seat depth: 21½"

When using a combination of fabrics or leathers, specify the application by designating the appropriate letter, shown below, on the purchase order. Yardage shown must be used.

See terms and conditions for contrasting upholstery upcharges.

- A) One fabric or leather for seat
yardage: 6.5 yds. leather: 110.0 sq. ft.
- B) One fabric or leather for back
yardage: 6.5 yds. leather: 110.0 sq. ft.
- C) One fabric or leather for back cushion
yardage: 5.0 yds. leather: 81.0 sq. ft.

SCS Indoor Advantage™ Gold and LEVEL® 2 certified. See terms and conditions for additional environmental information.

Seat Height	Arm Height	W	D	H	Fabric	Leather	Weight	Cubes/Qty
17½"	11"	86¾"	34"	27¼"	18.0 yds.	301.0'	290 lbs.	77.86'/1
445 mm	280 mm	2001 mm	864 mm	690 mm	16.5 m	28.0 sqm	132 kg	2.2 cu

COM	COL	1	2	3	4	5	6	7	8	9	10	11
8221	8581	9901	10181	10341	10661	10941	11061	11261	11541	11781	12061	13661

alloro 4D25FL

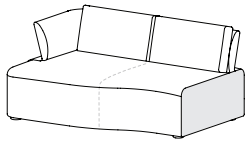

**Two-seat end connector
Left arm facing module
Left side flared front
Fully upholstered**

Two back cushions
Ganging brackets included
Freestanding option not available

Inside seat width: 53½", Inside seat depth: 21½"

When using a combination of fabrics or leathers, specify the application by designating the appropriate letter, shown below, on the purchase order. Yardage shown must be used.

See terms and conditions for contrasting upholstery upcharges.

- A) One fabric or leather for seat
yardage: 5.0 yds. leather: 81.0 sq. ft.
- B) One fabric or leather for back
yardage: 5.0 yds. leather: 81.0 sq. ft.
- C) One fabric or leather for back cushion
yardage: 3.5 yds. leather: 57.0 sq. ft.

SCS Indoor Advantage™ Gold and LEVEL® 2 certified. See terms and conditions for additional environmental information.

Seat Height	Arm Height	W	D	H	Fabric	Leather	Weight	Cubes/Qty
17½"	11"	61 ¼"	40⅝"	27¼"	13.5 yds.	219.0'	218 lbs.	64.69/1
445 mm	280 mm	1556 mm	1026 mm	690 mm	12.4 m	20.4 sqm	99.0 kg	1.9 cu

COM	COL	1	2	3	4	5	6	7	8	9	10	11
6706	6976	7966	8176	8296	8536	8746	8836	8986	9196	9376	9586	10786

alloro 4D25FR

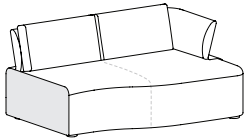

**Two-seat End Connector
Right arm facing module
Right side flared front
Fully upholstered**

Two back cushions
Ganging brackets included
Freestanding option not available

Inside seat width: 53½", Inside seat depth: 21½"

When using a combination of fabrics or leathers, specify the application by designating the appropriate letter, shown below, on the purchase order. Yardage shown must be used.

See terms and conditions for contrasting upholstery upcharges.

- A) One fabric or leather for seat
yardage: 5.0 yds. leather: 81.0 sq. ft.
- B) One fabric or leather for back
yardage: 5.0 yds. leather: 81.0 sq. ft.
- C) One fabric or leather for back cushion
yardage: 3.5 yds. leather: 57.0 sq. ft.

SCS Indoor Advantage™ Gold and LEVEL® 2 certified. See terms and conditions for additional environmental information.

Seat Height	Arm Height	W	D	H	Fabric	Leather	Weight	Cubes/Qty
17½"	11"	61¼"	40⅝"	27¼"	13.5 yds.	219.0'	218 lbs.	64.69/1
445 mm	280 mm	1556 mm	1026 mm	690 mm	12.4m	20.4 sqm	99.0 kg	1.9 cu

COM	COL	1	2	3	4	5	6	7	8	9	10	11
6706	6976	7966	8176	8296	8536	8746	8836	8986	9196	9376	9586	10786

alloro 4D37FL

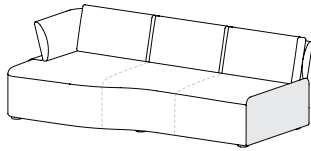

**Three-seat end connector
Left arm facing module
Left side flared front
Fully upholstered**

Three back cushions
Ganging brackets included
Freestanding option not available

Inside seat width: 78¾", Inside seat depth: 21½"

When using a combination of fabrics or leathers, specify the application by designating the appropriate letter, shown below, on the purchase order. Yardage shown must be used.

See terms and conditions for contrasting upholstery upcharges.

- A) One fabric or leather for seat
yardage: 7.75 yds. leather: 126.0 sq. ft.
- B) One fabric or leather for back
yardage: 6.5 yds. leather: 110.0 sq. ft.
- C) One fabric or leather for back cushion
yardage: 5.0 yds. leather: 81.0 sq. ft.

SCS Indoor Advantage™Gold and LEVEL® 2 certified. See terms and conditions for additional environmental information.

Seat Height	Arm Height	W	D	H	Fabric	Leather	Weight	Cubes/Qty
17½"	11"	86¾"	40¾"	27¼"	19.3 yds.	317.0'	303 lbs.	89.84'/1
445 mm	280 mm	2001 mm	1026 mm	690 mm	18.0 m	29.6 sqm	137.5 kg	2.6 cu

COM	COL	1	2	3	4	5	6	7	8	9	10	11
8221	8607	10023	10323	10495	10838	11138	11267	11481	11781	12039	12339	14054

alloro 4D37FR

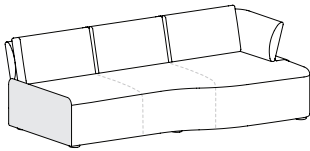

**Three-seat end connector
Right arm facing module
Right side flared front
Fully upholstered**

Three back cushions
Ganging brackets included
Freestanding option not available

Inside seat width: 78¾", Inside seat depth: 21½"

When using a combination of fabrics or leathers, specify the application by designating the appropriate letter, shown below, on the purchase order. Yardage shown must be used.

See terms and conditions for contrasting upholstery upcharges.

- A) One fabric or leather for seat
yardage: 7.75 yds. leather: 126.0 sq. ft.
- B) One fabric or leather for back
yardage: 6.5 yds. leather: 110.0 sq. ft.
- C) One fabric or leather for back cushion
yardage: 5.0 yds. leather: 81.0 sq. ft.

SCS Indoor Advantage™ Gold and LEVEL® 2 certified. See terms and conditions for additional environmental information.

Seat Height	Arm Height	W	D	H	Fabric	Leather	Weight	Cubes/Qty
17½"	11"	86¾"	40¾"	27¼"	19.3 yds.	317.0'	303 lbs.	89.84'/1
445 mm	280 mm	2001 mm	1026 mm	690 mm	18.0 m	29.6 sqm	137.5 kg	2.6 cu

COM	COL	1	2	3	4	5	6	7	8	9	10	11
8221	8607	10023	10323	10495	10838	11138	11267	11481	11781	12039	12339	14054

both sides connecting modules

alloro

alloro 4B25SL

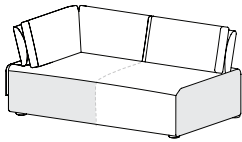

**Two-seat Connector
Left Arm facing module
Straight front
Fully upholstered**

Two back cushions
Ganging brackets included
Freestanding option not available

Inside seat width: 52½", Inside seat depth: 21½"

When using a combination of fabrics or leathers, specify the application by designating the appropriate letter, shown below, on the purchase order. Yardage shown must be used.

See terms and conditions for contrasting upholstery upcharges.

- A) One fabric or leather for seat
yardage: 4.5 yds leather: 73.0 sq. ft.
- B) One fabric or leather for back
yardage: 5.0 yds. leather: 81.0 sq. ft.
- C) One fabric or leather for back cushion
yardage: 5.0 yds. leather: 81.0 sq. ft.

SCS Indoor Advantage™ Gold and LEVEL® 2 certified. See terms and conditions for additional environmental information.

Seat Height	Arm Height	W	D	H	Fabric	Leather	Weight	Cubes/Qty
17½"	11"	61¼"	34"	27¼"	14.5 yds.	235.0'	208 lbs.	56.06'/1
445 mm	280 mm	1556 mm	864 mm	690 mm	13.3 m	22.0 sqm	94.4 kg	1.6 cu

COM	COL	1	2	3	4	5	6	7	8	9	10	11
6815	7105	8169	8394	8523	8781	9007	9103	9264	9490	9683	9909	11198

alloro 4B25SR

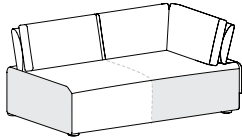

**Two-seat Connector
Right Arm facing module
Straight front
Fully upholstered**

Two back cushions
Ganging brackets included
Freestanding option not available

Inside seat width: 52½", Inside seat depth: 21½"

When using a combination of fabrics or leathers, specify the application by designating the appropriate letter, shown below, on the purchase order. Yardage shown must be used.

See terms and conditions for contrasting upholstery upcharges.

- A) One fabric or leather for seat
yardage: 4.5 yds leather: 73.0 sq. ft.
- B) One fabric or leather for back
yardage: 5.0 yds. leather: 81.0 sq. ft.
- C) One fabric or leather for back cushion
yardage: 5.0 yds. leather: 81.0 sq. ft.

SCS Indoor Advantage™ Gold and LEVEL® 2 certified. See terms and conditions for instructions for additional environmental information.

Seat Height	Arm Height	W	H	D	Fabric	Leather	Weight	Cubes/Qty
17½"	11"	61¼"	34"	27¼"	14.5 yds.	235.0'	208 lbs.	56.06'/1
445 mm	280 mm	1556 mm	864 mm	690 mm	13.3 m	22.0 sqm	94.4 kg	1.6 cu

COM	COL	1	2	3	4	5	6	7	8	9	10	11
6815	7105	8169	8394	8523	8781	9007	9103	9264	9490	9683	9909	11198

both sides connecting modules

alloro

alloro 4B37SL

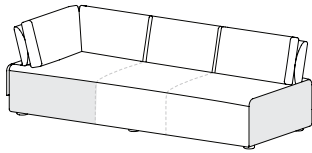

**Three-seat connector
Left arm facing module
Straight front
Fully upholstered**

Three back cushions
Ganging brackets included
Freestanding option not available

Inside seat width: 78¾", Inside seat depth: 21½"

When using a combination of fabrics or leathers, specify the application by designating the appropriate letter, shown below, on the purchase order. Yardage shown must be used.

See terms and conditions for contrasting upholstery upcharges.

- A) One fabric or leather for seat
yardage: 6.5 yds. leather: 110.0 sq. ft.
- B) One fabric or leather for back
yardage: 7.0 yds. leather: 114.0 sq. ft.
- C) One fabric or leather for back cushion
yardage: 6.5 yds. leather: 110.0 sq. ft.

SCS Indoor Advantage™ Gold and LEVEL® 2 certified. See terms and conditions for additional environmental information.

Seat Height	Arm Height	W	D	H	Fabric	Leather	Weight	Cubes/Qty
17½"	11"	86¾"	34"	27¼"	20.0 yds.	334.0'	290 lbs.	77.86'/1
445 mm	280 mm	2001 mm	864 mm	690 mm	18.3 m	31.1 sqm	132 kg	2.2 cu

COM	COL	1	2	3	4	5	6	7	8	9	10	11
8221	8621	10088	10399	10577	10933	11244	11377	11599	11910	12177	12488	14266

both sides connecting modules

alloro

alloro 4B37SR

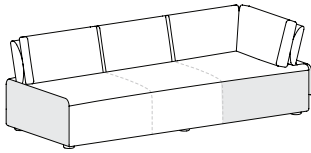

**Three-seat connector
Right arm facing module
Straight front
Fully upholstered**

Three back cushions
Ganging brackets included
Freestanding option not available

Inside seat width: 78¾", Inside seat depth: 21½"

When using a combination of fabrics or leathers, specify the application by designating the appropriate letter, shown below, on the purchase order. Yardage shown must be used.

See terms and conditions for contrasting upholstery upcharges.

- A) One fabric or leather for seat
yardage: 6.5 yds. leather: 110.0 sq. ft.
- B) One fabric or leather for back
yardage: 7.0 yds. leather: 114.0 sq. ft.
- C) One fabric or leather for back cushion
yardage: 6.5 yds. leather: 110.0 sq. ft.

SCS Indoor Advantage™ Gold and LEVEL® 2 certified. See terms and conditions for additional environmental information.

Seat Height	Arm Height	W	D	H	Fabric	Leather	Weight	Cubes/Qty
17½"	11"	86¾"	34"	27¼"	20.0 yds.	334.0'	290 lbs.	77.86'/1
445 mm	280 mm	2001 mm	864 mm	690 mm	18.3 m	31.1 sqm	132 kg	2.2 cu

COM	COL	1	2	3	4	5	6	7	8	9	10	11
8221	8621	10088	10399	10577	10933	11244	11377	11599	11910	12177	12488	14266

alloro 4B11SX

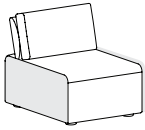

**Single seat connector
Straight front
Fully upholstered**

One back cushion
Ganging brackets included
Freestanding option not available

Inside seat width: 26¼", Inside seat depth: 21½"

When using a combination of fabrics or leathers, specify the application by designating the appropriate letter, shown below, on the purchase order. Yardage shown must be used.

See terms and conditions for contrasting upholstery upcharges.

- A) One fabric or leather for seat
yardage: 2.5 yds. leather: 41.0 sq. ft.
- B) One fabric or leather for back
yardage: 2.0 yds. leather: 31.0 sq. ft.
- C) One fabric or leather for back cushion
yardage: 2.0 yds. leather: 31.0 sq. ft.

SCS Indoor Advantage™ Gold and LEVEL® 2 certified. See terms and conditions for additional environmental information.

Seat Height	Arm Height	W	D	H	Fabric	Leather	Weight	Cubes/Qty
17½"	11"	26¼"	34"	27¼"	6.5 yds.	103.0'	78 lbs.	24.92'/1
445 mm	280 mm	667 mm	864 mm	690 mm	6.0 m	10.0 sqm	35.4 kg	.71 cu

COM	COL	1	2	3	4	5	6	7	8	9	10	11
2921	3051	3528	3629	3687	3803	3904	3947	4019	4120	4207	4308	4886

alloro 4B25SX

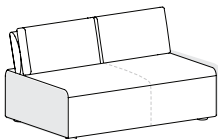

**Two-seat connector
Straight front
Fully upholstered**

Two back cushions
Ganging brackets included
Freestanding option not available

Inside seat width: 52½", Inside seat depth: 21½"

When using a combination of fabrics or leathers, specify the application by designating the appropriate letter, shown below, on the purchase order. Yardage shown must be used.

See terms and conditions for contrasting upholstery upcharges.

- A) One fabric or leather for seat
yardage: 4.5 yds leather: 73.0 sq. ft.
- B) One fabric or leather for back
yardage: 3.5 yds. leather: 57.0 sq. ft.
- C) One fabric or leather for back cushion
yardage: 3.5 yds. leather: 57.0 sq. ft.

SCS Indoor Advantage™ Gold and LEVEL® 2 certified. See terms and conditions for additional environmental information.

Seat Height	Arm Height	W	D	H	Fabric	Leather	Weight	Cubes/Qty
17½"	11"	52½"	34"	27¼"	11.5 yds.	187.0'	149 lbs.	46.72'/1
445 mm	280 mm	1337 mm	864 mm	690 mm	11.0 m	17.4 sqm	67.6 kg	1.3 cu

COM	COL	1	2	3	4	5	6	7	8	9	10	11
5841	6071	6915	7094	7196	7400	7579	7656	7784	7963	8116	8295	9317

alloro 4B37SX

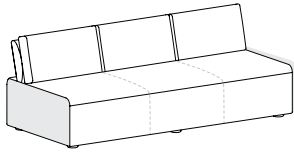

**Three-seat connector
Straight front
Fully upholstered**

Three back cushions
Ganging brackets included
Freestanding option not available

Inside seat width: 78¾", Inside seat depth: 21½"

When using a combination of fabrics or leathers, specify the application by designating the appropriate letter, shown below, on the purchase order. Yardage shown must be used.

See terms and conditions for contrasting upholstery upcharges.

- A) One fabric or leather for seat
yardage: 6.5 yds. leather: 110.0 sq. ft.
- B) One fabric or leather for back
yardage: 5.5 yds. leather: 90.0 sq. ft.
- C) One fabric or leather for back cushion
yardage: 5.0 yds. leather: 81.0s sq. ft.

SCS Indoor Advantage™ Gold and LEVEL® 2 certified. See terms and conditions for additional environmental information.

Seat Height	Arm Height	W	D	H	Fabric	Leather	Weight	Cubes/Qty
17½"	11"	78¾"	34"	27¼"	17.0 yds.	281.0'	217 lbs.	66.18
445 mm	280 mm	2004 mm	864 mm	690 mm	16.0 m	26.2 sqm	98.5 kg	1.9 cu

COM	COL	1	2	3	4	5	6	7	8	9	10	11
7139	7479	8726	8991	9142	9444	9708	9822	10011	10275	10502	10766	12277

Becca Seating System Specification Guide

The Becca Lounge Collection is fully upholstered and includes 6 freestanding skus and 14 unique modules. Becca freestanding units come with non-leveling guides. The Becca modular units come with leveling non-marring glides.

Modules can be used interchangeably to create an unlimited number of configurations. To select the modules that are appropriate for your application use the guide below. All necessary ganging brackets are included and pre-installed. The Becca modules can only be used in conjunction with other Becca modules and are not intended to be used as freestanding components.

All COM/COL fabrics must be preapproved by Bernhardt Design prior to application. SCS Indoor Advantage™ Gold and LEVEL® 2 certified. See terms and conditions for additional environmental information.

When ordering multi-item configurations, please provide the total COM yardage from the same dye lot in a continuous roll(s).

Please visit Bernhardtdesign.com for a complete library of 2D, 3D and Revit models. You may also contact your local sales representative or the Bernhardt Design corporate office for specification assistance.

Product Selection

A. End Modules

All Becca configurations must include an end module on each end of the configuration.

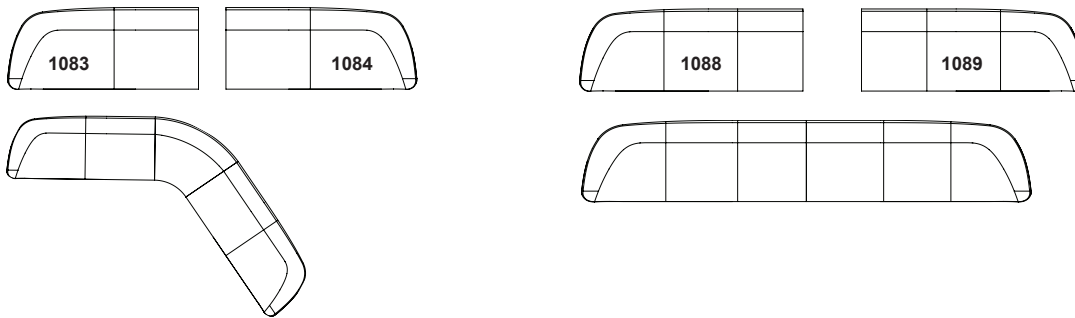

B. 45° Connecting Modules

Connecting modules are used in conjunction with end modules. 45° Connecting modules may not be used at the end of a configuration or as a freestanding unit.

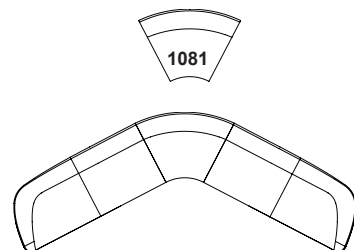

C. 90° Connecting Modules

Connecting modules are used in conjunction with end modules. 90° Connecting modules may not be used at the end of a configuration or as a freestanding unit.

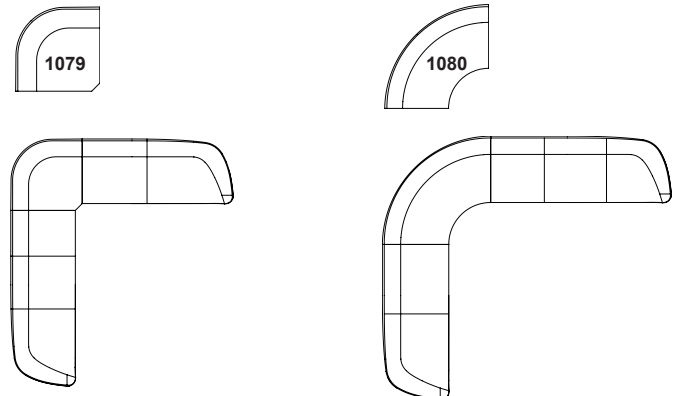

Becca Seating System Sample Configurations

SKU Description

1

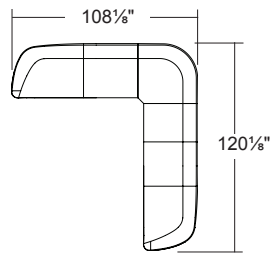
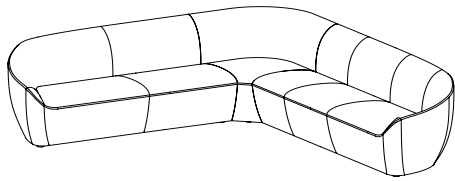

- 1083** Two-seat. Left Arm Facing Module
- 1079** 90° Straight Corner Module
- 1089** Three-seat. Right Arm Facing Module

2

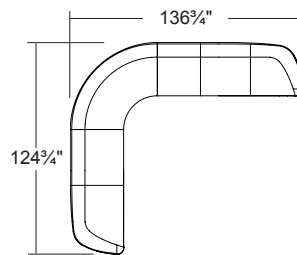
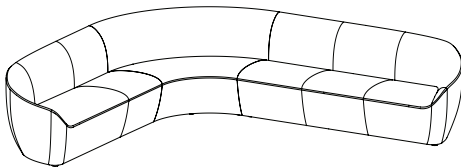

- 1083** Two-seat. Left Arm Facing Module
- 1080** 90° Curved Corner Module
- 1089** Three-seat. Right Arm Facing Module

3

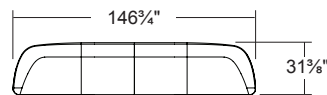
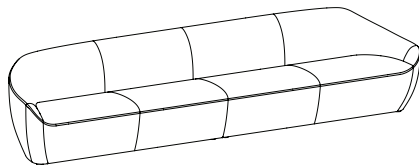

- 1083** Two-seat. Left Arm Facing Module
- 1084** Two-seat. Right Arm Facing Module

4

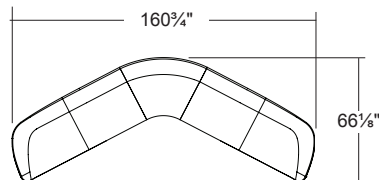
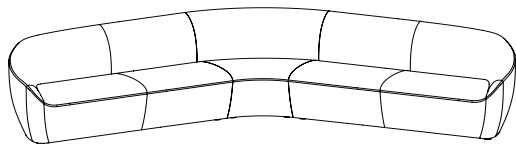

- 1083** Two-seat. Left Arm Facing Module
- 1081** 45° Curved Corner Module
- 1084** Two-seat. Right Arm Facing Module

becca 1083

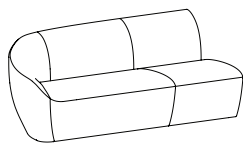

**Two-seat
Left arm facing module
Fully upholstered
Standard with plain welt
Saddle stitched seams on the inside and outside**

Leveling non-marring glides
All necessary ganging brackets are included and pre-installed

Inside seat width: 65", Inside seat depth: 22"

When using a combination of fabrics or leathers, specify the application by designating the appropriate letter, shown below, on the purchase order. Yardage shown must be used.

See terms and conditions for contrasting upholstery upcharges.

- A) One fabric or leather for inback and seat
yardage: 6.0 yds. leather: 100.0 sq ft.
- B) One fabric or leather for outback
yardage: 5.0 yds. leather: 80.0 sq. ft.
- C) One fabric or leather for welt
yardage: 1.5 yds. leather: 18.0 sq. ft.

When using decorative trim for welt order:
yardage: 12.0 yds 5mm cord

SCS Indoor Advantage™ Gold and LEVEL® 2 certified. See terms and conditions for additional environmental information.

Seat Height	Arm Height	W	D	H	Fabric	Leather	Weight	Cubes/Qty
18"	6"	74"	31½"	31½"	11.0 yds.	180.0'	170 lbs.	100.22/1
457 mm	152 mm	1880 mm	810 mm	797 mm	10.1 m	16.7 sqm	77.1 kg	2.8 cu.

COM	COL	1	2	3	4	5	6	7	8	9	10	11
4449	4669	5476	5647	5745	5941	6112	6185	6307	6478	6625	6796	7774

becca 1083L

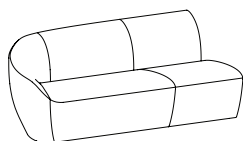

**Two-seat
Left arm facing module
Available In leather only
Bespoke leather welt
Saddled stitched seams on the inside and outside**

Leveling non-marring glides
All necessary ganging brackets are included and pre-installed

Inside seat width: 65", Inside seat depth: 22"

Bespoke Leather Welt Specification: Thread color must be specified. Reference Becca/Stitching on bernhardtdesign.com for color options.

SCS Indoor Advantage™ Gold and LEVEL® 2 certified. See terms and conditions for additional environmental information.

Seat Height	Arm Height	W	D	H	Fabric	Leather	Weight	Cubes/Qty
18"	6"	74"	31½"	31½"	-	180.0'	170 lbs.	100.22/1
457 mm	152 mm	1880 mm	810 mm	797 mm	-	16.7 sqm	77.1 kg	2.8 cu.

COL
5781

becca 1084

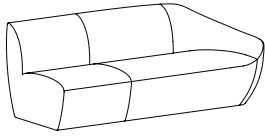

**Two-seat
Right arm facing module
Fully upholstered
Standard with plain welt
Saddled stitched seams on the inside and outside**

Leveling non-marring glides
All necessary ganging brackets are included and pre-installed

Inside seat width: 65", Inside seat depth: 22"

When using a combination of fabrics or leathers, specify the application by designating the appropriate letter, shown below, on the purchase order. Yardage shown must be used.

See terms and conditions for contrasting upholstery upcharges.

- A) One fabric or leather for inback and seat
yardage: 6.0 yds. leather: 100.0 sq ft.
- B) One fabric or leather for outback
yardage: 5.0 yds. leather: 80.0 sq. ft.
- C) One fabric or leather for welt
yardage: 1.5 yds. leather: 18.0 sq. ft.

When using decorative trim for welt order:
yardage: 12.0 yds. 5mm cord

SCS Indoor Advantage™ Gold and LEVEL® 2 certified. See terms and conditions for additional environmental information.

Seat Height	Arm Height	W	D	H	Fabric	Leather	Weight	Cubes/Qty
18"	-	74"	31 ⁷ / ₈ "	31 ³ / ₈ "	11.0 yds.	180.0'	170 lbs.	100.227/1
457 mm	-	1880 mm	810 mm	797 mm	10.1 m	16.7 sqm	77.1 kg	2.8 cu.

COM	COL	1	2	3	4	5	6	7	8	9	10	11
4449	4669	5476	5647	5745	5941	6112	6185	6307	6478	6625	6796	7774

becca 1084L

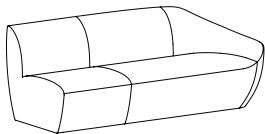

**Two-seat
Right arm facing module
Available In leather only
Bespoke leather welt
Saddled stitched seams on the inside and outside**

Leveling non-marring glides
All necessary ganging brackets are included and pre-installed

Inside seat width: 65", Inside seat depth: 22"

Bespoke Leather Welt Specification: Thread color must be specified. Reference Becca/Stitching on bernhardtdesign.com for color options.

SCS Indoor Advantage™ Gold and LEVEL® 2 certified. See terms and conditions for additional environmental information.

Seat Height	Arm Height	W	D	H	Fabric	Leather	Weight	Cubes/Qty
18"	6"	74"	31 ⁷ / ₈ "	31 ³ / ₈ "	-	180.0'	170 lbs.	100.227/1
457 mm	152 mm	1880 mm	810 mm	797 mm	-	16.7 sqm	77.1 kg	2.8 cu.

COL
5781

becca 1088

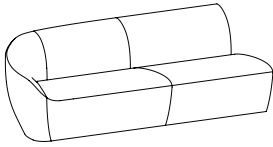

**Three-seat
Left arm facing module
Fully upholstered
Standard with plain welt
Saddled stitched seams on the inside and outside**

Leveling non-marring glides
All necessary ganging brackets are included and pre-installed

Inside seat width: 77", Inside seat depth: 22"

When using a combination of fabrics or leathers, specify the application by designating the appropriate letter, shown below, on the purchase order. Yardage shown must be used.

See terms and conditions for contrasting upholstery upcharges.

- A) One fabric or leather for inback and seat
yardage: 7.0 yds. leather: 114.0 sq. ft.
- B) One fabric or leather for outback
yardage: 7.1 yds. leather: 115.0 sq. ft.
- C) One fabric or leather for welt
yardage: 1.5 yds. leather: 18.0 sq. ft.

When using decorative trim for welt order:
yardage: 15.0 yds. 5mm cord

SCS Indoor Advantage™ Gold and LEVEL® 2 certified. See terms and conditions for additional environmental information.

Seat Height	Arm Height	W	D	H	Fabric	Leather	Weight	Cubes/Qty
18"	6"	86"	31 ⁷ / ₈ "	31 ¹ / ₈ "	14.1 yds.	230.0'	189 lbs.	101.65'/1
457 mm	152 mm	2184 mm	810 mm	797 mm	12.9 m	21.4 sqm	85.7 kg	2.9 cu.

COM	COL	1	2	3	4	5	6	7	8	9	10	11
5561	5843	6877	7097	7222	7473	7692	7786	7943	8162	8350	8569	9823

becca 1088L

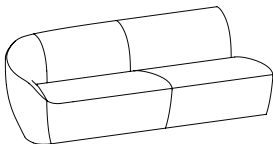

**Three-seat
Left arm facing module
Available in leather only
Bespoke leather welt
Saddled stitch seams on the inside and outside**

Leveling non-marring glides
All necessary ganging brackets are included and pre-installed

Inside seat width: 77", Inside seat depth: 22"

Bespoke Leather Welt Specification: Thread color must be specified. Reference Becca/Stitching on bernhardtdesign.com for color options.

SCS Indoor Advantage™ Gold and LEVEL® 2 certified. See terms and conditions for additional environmental information.

Seat Height	Arm Height	W	D	H	Fabric	Leather	Weight	Cubes/Qty
18"	6"	86"	31 ⁷ / ₈ "	31 ¹ / ₈ "	-	230.0'	189 lbs.	101.65'/1
457 mm	152 mm	2184 mm	810 mm	797 mm	-	21.4 sqm	85.7 kg	2.9 cu.

COL
7234

becca 1089

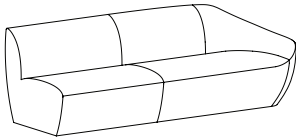

**Three-seat
Right arm facing module
Fully upholstered
Standard with plain welt
Saddled stitched seams on the inside and outside**

Leveling non-marring glides
All necessary ganging brackets are included and pre-installed

Inside seat width: 77", Inside seat depth: 22"

When using a combination of fabrics or leathers, specify the application by designating the appropriate letter, shown below, on the purchase order. Yardage shown must be used.

See terms and conditions for contrasting upholstery upcharges.

- A) One fabric or leather for inback and seat
yardage: 7.0 yds. leather: 114.0 sq. ft.
- B) One fabric or leather for outback
yardage: 7.1 yds. leather: 115.0 sq. ft.
- C) One fabric or leather for welt
yardage: 1.5 yds. leather: 18.0 sq. ft.

When using decorative trim for welt order:
yardage: 15.0 yds. 5mm cord

SCS Indoor Advantage™ Gold and LEVEL® 2 certified. See terms and conditions for additional environmental information.

Seat Height	Arm Height	W	D	H	Fabric	Leather	Weight	Cubes/Qty
18"	6"	86"	31 ⁷ / ₈ "	31 ¹ / ₈ "	14.1 yds.	230.0'	189 lbs.	101.65'/1
457 mm	152 mm	2184 mm	810 mm	797 mm	12.9 m	21.4 sqm	85.7 kg	2.9 cu.

COM	COL	1	2	3	4	5	6	7	8	9	10	11
5561	5843	6877	7097	7222	7473	7692	7786	7943	8162	8350	8569	9823

becca 1089L

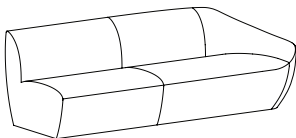

**Three-seat
Right arm facing module
Available in leather only
Bespoke leather welt
Saddle stitched seams on the inside and outside**

Leveling non-marring glides
All necessary ganging brackets are included and pre-installed

Inside seat width: 77", Inside seat depth: 22"

Bespoke Leather Welt Specification: Thread color must be specified. Reference Becca/Stitching on bernhardtdesign.com for color options.

SCS Indoor Advantage™ Gold and LEVEL® 2 certified. See terms and conditions for additional environmental information.

Seat Height	Arm Height	W	D	H	Fabric	Leather	Weight	Cubes/Qty
18"	6"	86"	31 ⁷ / ₈ "	31 ¹ / ₈ "	-	230.0'	189 lbs.	101.65'/1
457 mm	152 mm	2184 mm	810 mm	797 mm	-	21.4 sqm	85.7 kg	2.9 cu.

COL
7234

becca 1079

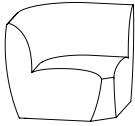

90° straight corner module
Fully upholstered
Standard with plain welt
Saddled stitched seams on the inside and outside

Leveling non-marring glides
 All necessary ganging brackets are included and pre-installed

Inside seat width: 28 $\frac{3}{8}$ ", Inside seat depth: 21 $\frac{1}{8}$ "

When using a combination of fabrics or leathers, specify the application by designating the appropriate letter, shown below, on the purchase order. Yardage shown must be used.

See terms and conditions for contrasting upholstery upcharges.

- A) One fabric or leather for inback and seat
 yardage: 3.6 yds. leather: 59.0 sq ft.
- B) One fabric or leather for outback
 yardage: 4.5 yds. leather: 75.0 sq. ft.
- C) One fabric or leather for welt
 yardage: 1.5 yds. leather: 18.0 sq. ft.

When using decorative trim for welt order:
 yardage: 7.0 yds. 5mm cord

SCS Indoor Advantage™ Gold and LEVEL® 2 certified. See terms and conditions for additional environmental information.

Seat Height	Arm Height	W	D	H	Fabric	Leather	Weight	Cubes/Qty
18"	-	35 $\frac{1}{4}$ "	35 $\frac{1}{4}$ "	31 $\frac{1}{8}$ "	8.1 yds.	135.0'	122 lbs.	36.09/1
457 mm	-	895 mm	895 mm	797 mm	7.4 m	12.5 sqm	55.3 kg	1.02 cu.

COM	COL	1	2	3	4	5	6	7	8	9	10	11
3198	3360	3954	4080	4152	4296	4422	4476	4566	4692	4800	4926	5646

becca 1079L



90° straight corner module
Available in leather only
Bespoke leather welt
Saddle stitched seams on the inside and outside

Leveling non-marring glides
 All necessary ganging brackets are included and pre-installed

Inside seat width: 28 $\frac{3}{8}$ ", Inside seat depth: 21 $\frac{1}{8}$ "

Bespoke Leather Welt Specification: Thread color must be specified. Reference Becca/Stitching on Bernhardttdesign.com for COL or options.

SCS Indoor Advantage™ Gold and LEVEL® 2 certified. See terms and conditions for additional environmental information.

Seat Height	Arm Height	W	D	H	Fabric	Leather	Weight	Cubes/Qty
18"	-	35 $\frac{1}{4}$ "	35 $\frac{1}{4}$ "	31 $\frac{1}{8}$ "	-	135.0'	122 lbs.	36.09/1
457 mm	-	895 mm	895 mm	797 mm	-	12.5 sqm	55.3 kg	1.02 cu.

COL
4195

becca 1080

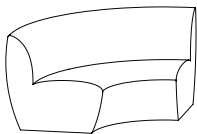

90° Curved corner module
Fully upholstered
Standard with plain welt
Saddle stitched seams on the inside and outside

Leveling non-marring glides
 All necessary ganging brackets are included and pre-installed

Inside seat width: 47", Inside seat depth: 21 1/8"

When using a combination of fabrics or leathers, specify the application by designating the appropriate letter, shown below, on the purchase order. Yardage shown must be used.

See terms and conditions for contrasting upholstery upcharges.

- A) One fabric or leather for inback and seat
 yardage: 4.5 yds. leather: 75.0 sq ft.
- B) One fabric or leather for outback
 yardage: 4.3 yds. leather: 70.0 sq. ft.
- C) One fabric or leather for welt
 yardage: 1.5 yds. leather: 18.0 sq. ft.

When using decorative trim for welt order
 yardage: 10.0 yds. 5mm cord

SCS Indoor Advantage™ Gold and LEVEL® 2 certified. See terms and conditions for additional environmental information.

Seat Height	Arm Height	W	D	H	Fabric	Leather	Weight	Cubes/Qty
18"	-	72 1/2"	51"	31 1/8"	8.8 yds.	145.0'	142 lbs.	100.22'/1
457 mm	-	1842 mm	1295 mm	797 mm	8.0 m	13.5 sqm	64.4 kg	2.8 cu.

COM	COL	1	2	3	4	5	6	7	8	9	10	11
4449	4625	5271	5408	5486	5642	5779	5838	5936	6073	6190	6327	7109

becca 1080L

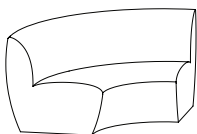

90° Curved corner module
Available in leather only
Bespoke leather welt
Saddled stitch seams on the inside and outside

Leveling non-marring glides
 All necessary ganging brackets are included and pre-installed

Inside seat width: 47", Inside seat depth: 21 1/8"

Bespoke Leather Welt Specification: Thread color must be specified. Reference Becca/Stitching on Bernhardttdesign.com for COL or options.

SCS Indoor Advantage™ Gold and LEVEL® 2 certified. See terms and conditions for additional environmental information.

Seat Height	Arm Height	W	D	H	Fabric	Leather	Weight	Cubes/Qty
18"	-	72 1/2"	51"	31 1/8"	-	145.0'	142 lbs.	100.22'/1
457 mm	-	1842 mm	1295 mm	797 mm	-	13.5 sqm	64.4 kg	2.8 cu.

COL
5598

becca 1081



45° Curved corner module
Fully upholstered
Standard with plain welt
Saddled stitched seams on the inside and outside

Leveling non-marring glides
 All necessary ganging brackets are included and pre-installed

Inside seat width: 20¾", Inside seat depth: 28⅞"

When using a combination of fabrics or leathers, specify the application by designating the appropriate letter, shown below, on the purchase order. Yardage shown must be used.

See terms and conditions for contrasting upholstery upcharges.

- A) One fabric or leather for inback and seat
 yardage: 3.5 yds. leather: 58.0 sq ft.
- B) One fabric or leather for outback
 yardage: 2.6 yds. leather: 43.0 sq. ft.
- C) One fabric or leather for welt
 yardage: 1.5 yds. leather: 18.0 sq. ft.

When using decorative trim for welt order:
 yardage: 7.0 yds. 5mm cord

SCS Indoor Advantage™ Gold and LEVEL® 2 certified. See terms and conditions for additional environmental information.

Seat Height	Arm Height	W	D	H	Fabric	Leather	Weight	Cubes/Qty
18"	-	39½"	41⅞"	31⅞"	6.1 yds.	100.0'	101 lbs.	44.0'/1
457 mm	-	1003 mm	1051 mm	797 mm	5.6 m	9.3 sqm	45.8 kg	1.2 cu.

COM	COL	1	2	3	4	5	6	7	8	9	10	11
2921	3043	3491	3586	3640	3748	3843	3884	3952	4047	4128	4223	4765

becca 1081L

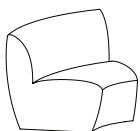

45° Curved corner module
Available in leather only
Bespoke leather welt
Saddled stitched seams on the inside and outside

Leveling non-marring glides
 All necessary ganging brackets are included and pre-installed

Inside seat width: 20¾" , Inside seat depth: 28⅞"

Bespoke Leather Welt Specification: Thread color must be specified. Reference Becca/Stitching on bernhardtdesign.com for color options

SCS Indoor Advantage™ Gold and LEVEL® 2 certified. See terms and conditions for additional environmental information.

Seat Height	Arm Height	W	D	H	Fabric	Leather	Weight	Cubes/Qty
18"	-	39½"	41⅞"	31⅞"	-	100.0'	101 lbs.	44.07'/1
457 mm	-	1003 mm	1051 mm	797 mm	-	9.3 sqm	45.8 kg	1.2 cu.

COL
3738

Casino Seating System Specification Guide

Casino is a modular seating product comprised of eleven unique modules which may be used interchangeably to create an unlimited number of configurations. All Casino configurations must include an end module on each end of the configuration. To select the modules that are appropriate for your application use the guide below.

When ordering multi-item configurations, please provide the total COM yardage from the same dye lot in a continuous roll(s).

Casino is fully upholstered with leveling non-marring glides. All necessary ganging brackets are included and pre-installed.*All COM/ COL fabrics must be preapproved by Bernhardt Design prior to application. SCS Indoor Advantage™ Gold and LEVEL® 2 certified. See terms and conditions for additional environmental information

Please visit Bernhardtdesign.com for a complete library of 2D, 3D and Revit models. You may also contact your local sales representative or the Bernhardt Design corporate office for specification assistance.

Product Selection

A. End Modules

All Casino configurations must include an end module on each end of the configuration.

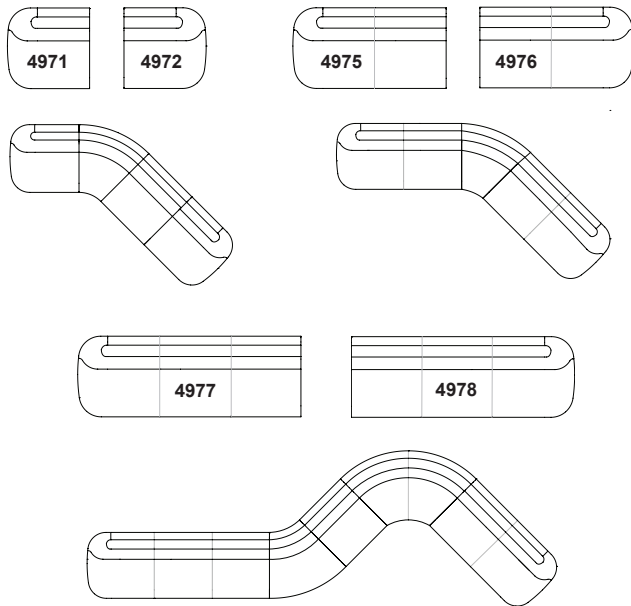

B. 45° Connecting Modules

Connecting modules are used in conjunction with end modules. 45° connecting modules may not be used at the end of a configuration or as a freestanding unit.

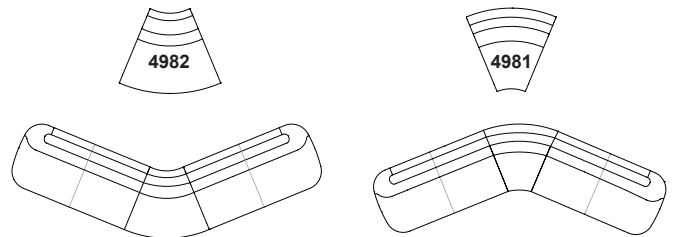

C. 90° Connecting Modules

Connecting modules are used in conjunction with end modules. 90° connecting modules may not be used at the end of a configuration or as a freestanding unit.

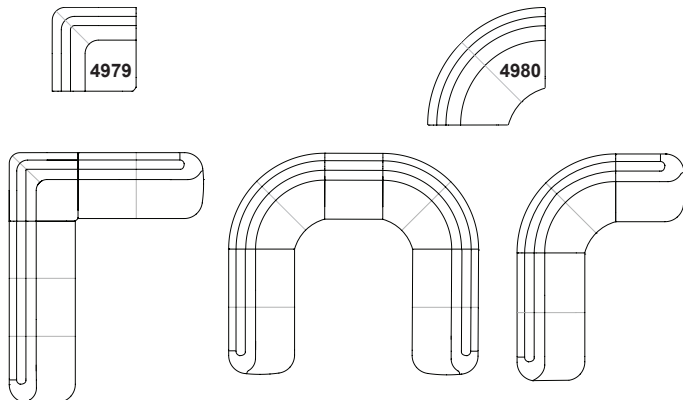

D. Straight Connecting Module

Connecting modules are used in conjunction with end modules. Straight connecting modules may not be used at the end of a configuration or as a freestanding unit.

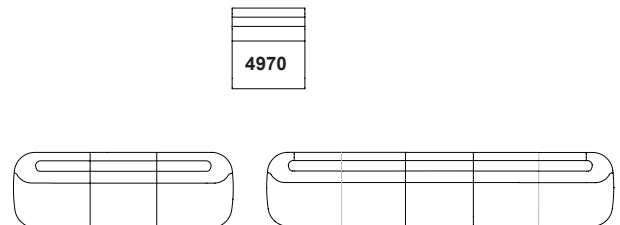

Casino Seating System Overview

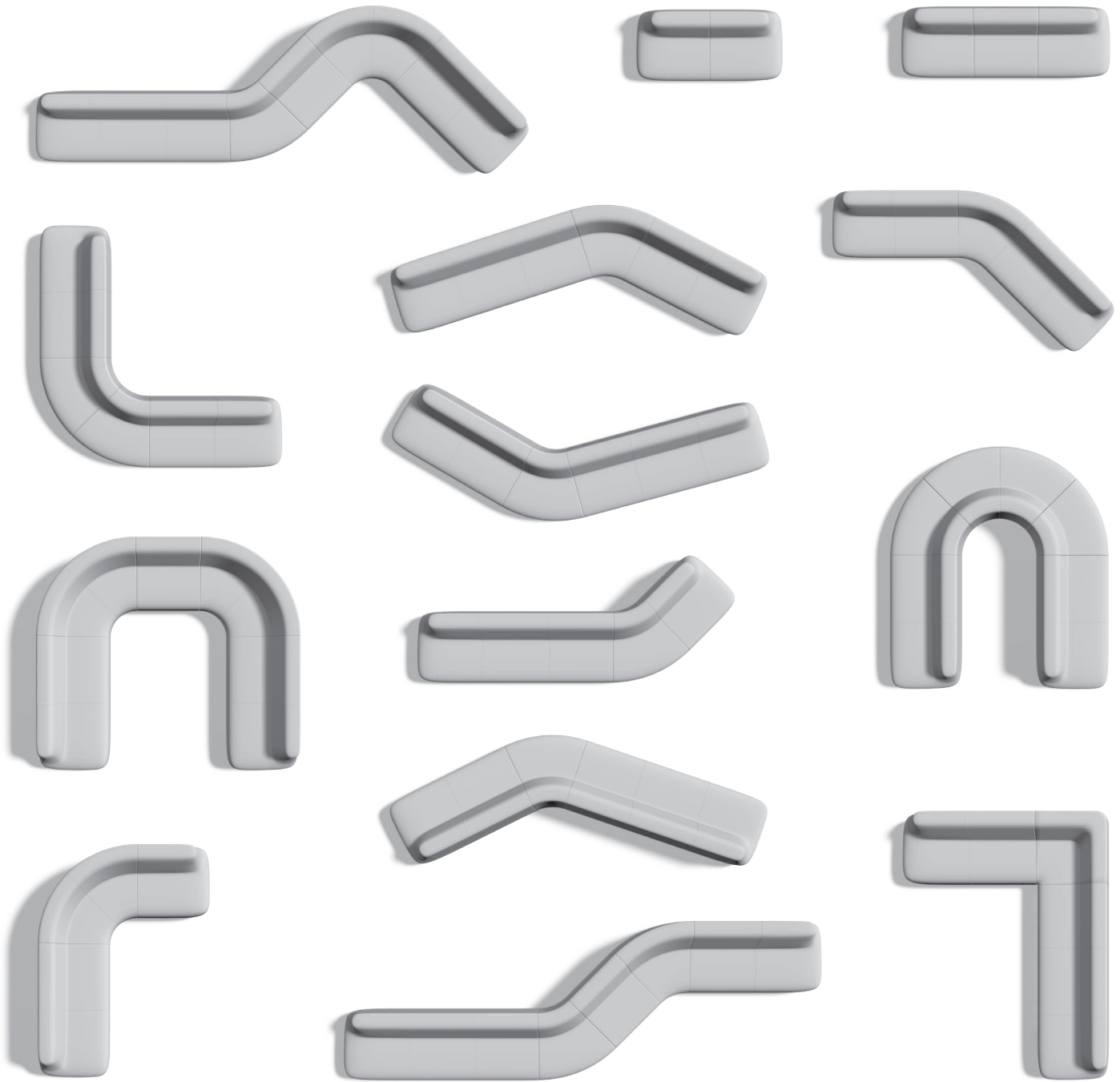

Casino Seating System Sample Configurations

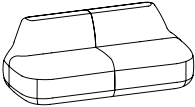
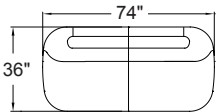
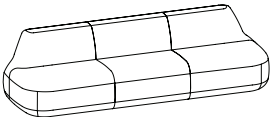
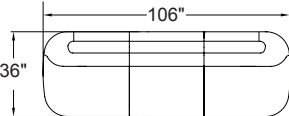
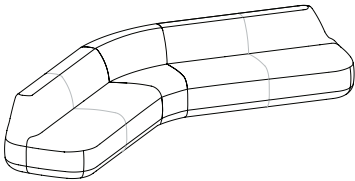
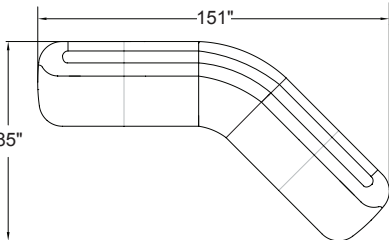
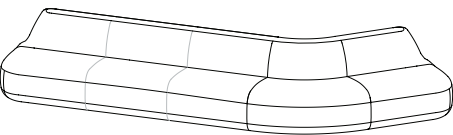
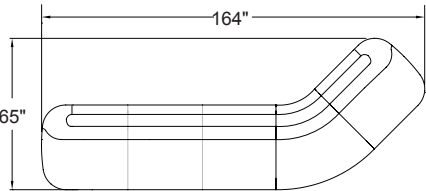
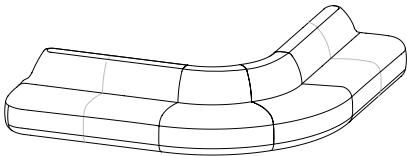
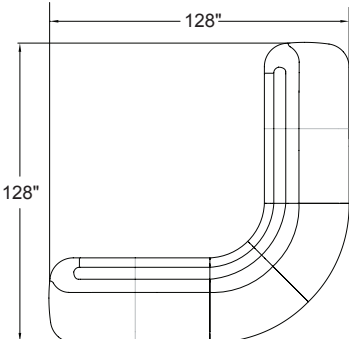
		Sku	Description
1	 	4971 4972	Left End Facing Module Right End Facing Module
2	 	4971 4970 4972	Left End Facing Module Straight Connector Right End Facing Module
3	 	4975 4981 4976	Two-seat, Left End Facing Module 45° Curved Connector Two-seat, Right End Facing Module
4	 	4977 4982 4972	Three-seat, Left End Facing Module 45° Inverted Curved Connector Right End Facing Module
5	 	4975 4982 4976	Two-seat, Left End Facing Module 45° Inverted Curved Connector (2) Two-seat, Right End Facing Module

Casino Seating System Sample Configurations

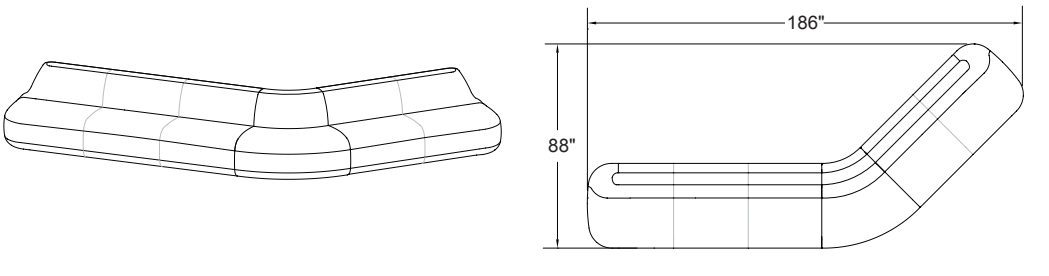
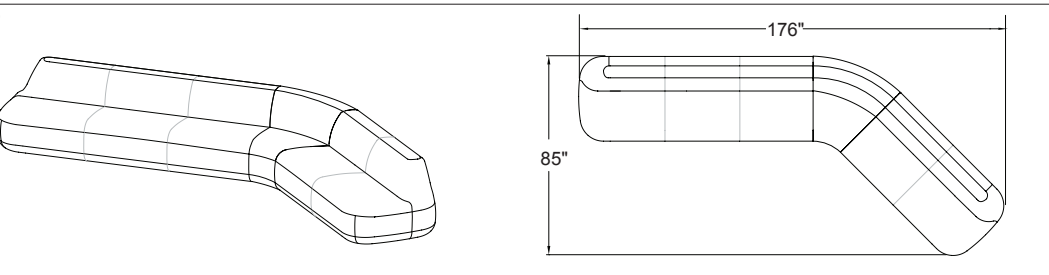
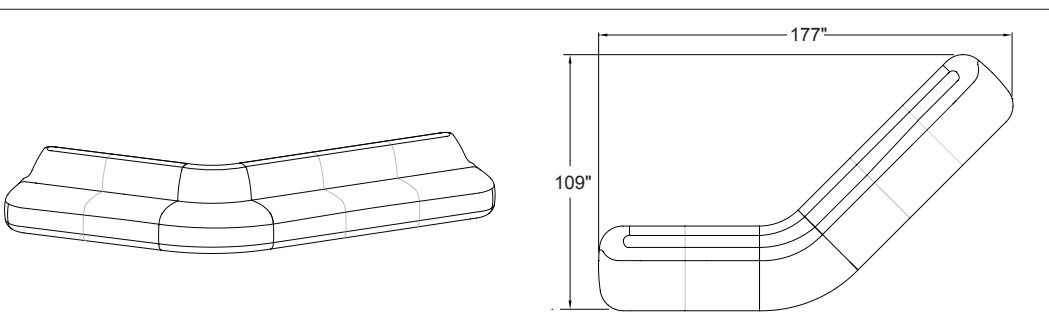
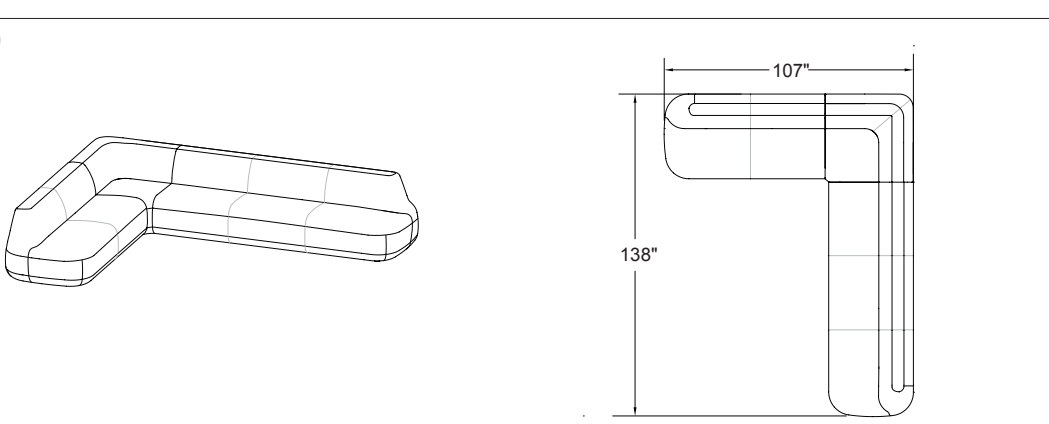
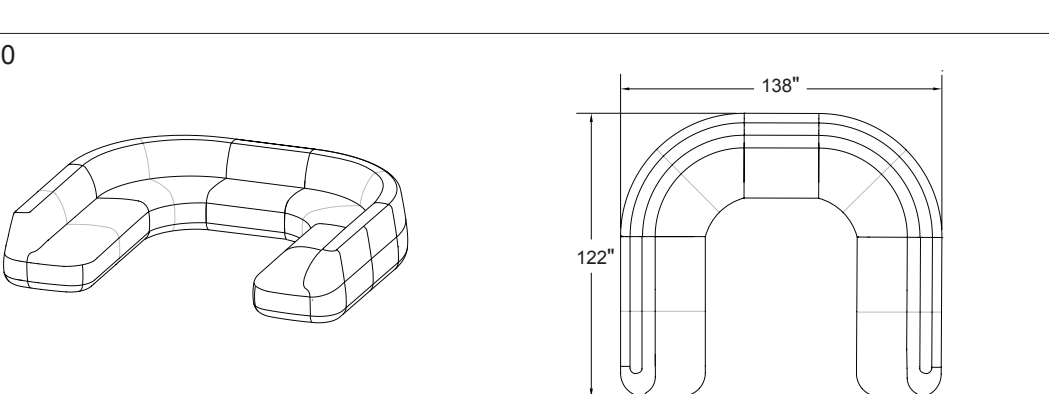
6		<p>4977 Three-seat, Left End Facing Module 4982 45° Inverted Curved Connector 4976 Two-seat, Right End Facing Module</p>
7		<p>4977 Three-seat, Left End Facing Module 4981 45° Curved Connector 4976 Two-seat, Right End Facing Module</p>
8		<p>4975 Two-seat, Left End Facing Module 4982 45° Inverted Curved Connector 4978 Three-seat, Right End Facing Module</p>
9		<p>4975 Two-seat, Left End Facing Module 4979 Square Corner Connector 4978 Three-seat, Right End Facing Module</p>
10		<p>4975 Two-seat, Left End Facing Module 4980 90° Curved Connector 4970 Single Straight Connector 4980 90° Curved Connector 4976 Two-seat, Right End Facing Module</p>

Casino Seating System Sample Configurations

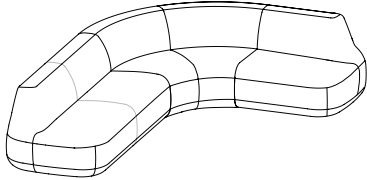
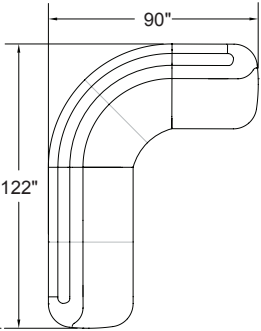
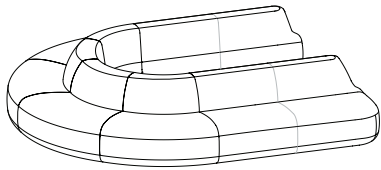
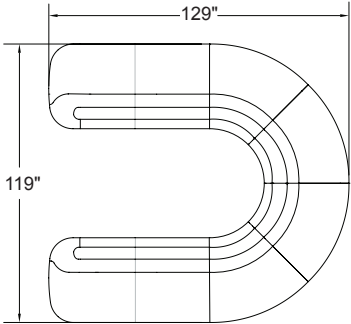
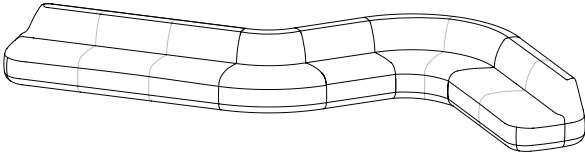
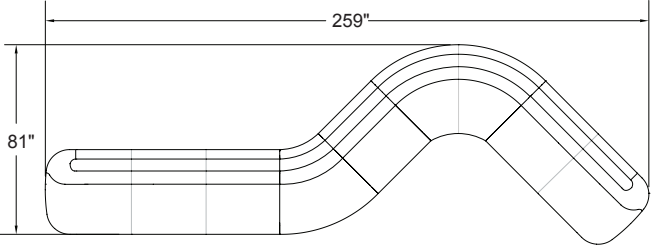
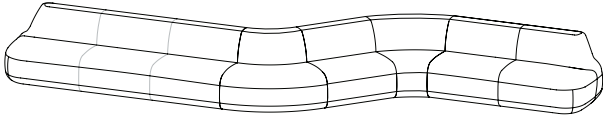
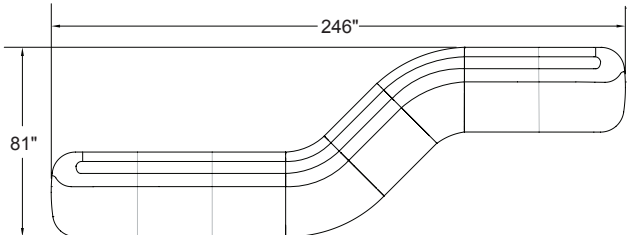
11	Sku Description
	<p>4975 Two-seat, Left End Facing Module 4980 90° Curved Connector 4972 Right End Facing Module</p>
	
12	<p>4976 Two-seat, Right End Facing Module 4982 45° Inverted Curved Connector (4) 4975 Two-seat, Left End Facing Module</p>
	
13	<p>4977 Three-seat, Left End Facing Module 4982 45° Inverted Curved Connector 4970 Single Straight Connector 4980 90° Curved Connector 4976 Two-seat, Right End Facing Module</p>
	
14	<p>4977 Three-seat, Left End Facing Module 4982 45° Inverted Curved Connector 4970 Single Straight Connector 4981 45° Curved Connector 4976 Two-seat, Right End Facing Module</p>
	

casino 4971

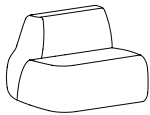

**Left end facing module
Fully upholstered**

All necessary ganging brackets are included and pre-installed

SCS Indoor Advantage™ Gold and LEVEL® 2 certified. See terms and conditions for additional environmental information.

Seat Height	Arm Height	W	D	H	Fabric	Leather	Weight	Cubes/Qty
17"	-	37"	36¼"	28¼"	6.0 yds.	100.0'	90 lbs.	32.10'/1
432 mm	-	940 mm	921 mm	718 mm	5.5 m	9.3 sqm	40.8 kg	0.91 cu.

COM	COL	1	2	3	4	5	6	7	8	9	10	11
2418	2538	2978	3072	3125	3232	3325	3365	3432	3525	3605	3698	4232

casino 4972



**Right end facing module
Fully upholstered**

All necessary ganging brackets are included and pre-installed

SCS Indoor Advantage™ Gold and LEVEL® 2 certified. See terms and conditions for additional environmental information.

Seat Height	Arm Height	W	D	H	Fabric	Leather	Weight	Cubes/Qty
17"	-	37"	36¼"	28¼"	6.0 yds.	100.0'	90 lbs.	32.10'/1
432 mm	-	940 mm	921 mm	718 mm	5.5 m	9.3 sqm	40.8 kg	0.91 cu.

COM	COL	1	2	3	4	5	6	7	8	9	10	11
2418	2538	2978	3072	3125	3232	3325	3365	3432	3525	3605	3698	4232

casino 4975

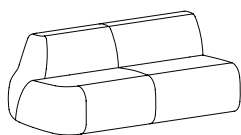

**Two-seat
Left end facing
Fully upholstered module**

All necessary ganging brackets are included and pre-installed

SCS Indoor Advantage™ Gold and LEVEL® 2 certified. See terms and conditions for additional environmental information.

Seat Height	Arm Height	W	D	H	Fabric	Leather	Weight	Cubes/Qty
17"	-	69"	36¼"	28¼"	8.5 yds.	138.0'	145 lbs.	80.67'/1
432 mm	-	1753 mm	921 mm	718 mm	7.8 m	12.8 sqm	65.7 kg	2.28 cu.

COM	COL	1	2	3	4	5	6	7	8	9	10	11
4186	4356	4980	5112	5188	5339	5471	5528	5622	5754	5868	6000	6755

casino 4976

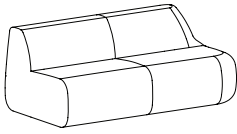

**Two-seat
Right end facing module
Fully upholstered**

All necessary ganging brackets are included and pre-installed

SCS Indoor Advantage™ Gold and LEVEL® 2 certified. See terms and conditions for additional environmental information.

Seat Height	Arm Height	W	D	H	Fabric	Leather	Weight	Cubes/Qty
17"	-	69"	36¼"	28¼"	8.5 yds.	138.0'	145 lbs.	80.67/1
432 mm	-	1753 mm	921 mm	718 mm	7.8 m	12.8 sqm	65.7 kg	2.28 cu.

COM	COL	1	2	3	4	5	6	7	8	9	10	11
4186	4356	4980	5112	5188	5339	5471	5528	5622	5754	5868	6000	6755

casino 4977

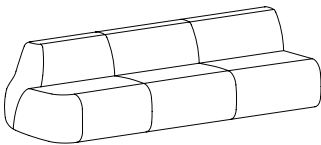

**Three-seat
Left end facing module
Fully upholstered**

All necessary ganging brackets are included and pre-installed

SCS Indoor Advantage™ Gold and LEVEL® 2 certified. See terms and conditions for additional environmental information.

Seat Height	Arm Height	W	D	H	Fabric	Leather	Weight	Cubes/Qty
17"	-	100½"	36¼"	28¼"	12.25 yds.	200.0'	220 lbs.	97.97/1
432 mm	-	2553 mm	921 mm	718 mm	11.2 m	18.6 sqm	99.8 kg	2.77 cu.

COM	COL	1	2	3	4	5	6	7	8	9	10	11
5312	5557	6456	6646	6755	6973	7164	7245	7381	7572	7735	7926	9015

casino 4978

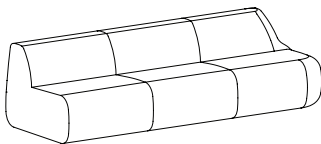

**Three-seat
Right end facing module
Fully upholstered**

All necessary ganging brackets are included and pre-installed

SCS Indoor Advantage™ Gold and LEVEL® 2 certified. See terms and conditions for additional environmental information.

Seat Height	Arm Height	W	D	H	Fabric	Leather	Weight	Cubes/Qty
17"	-	100½"	36¼"	28¼"	12.25 yds.	200.0'	220 lbs.	97.97/1
432 mm	-	2553 mm	921 mm	718 mm	11.2 m	18.6 sqm	99.8 kg	2.77 cu.

COM	COL	1	2	3	4	5	6	7	8	9	10	11
5312	5557	6456	6646	6755	6973	7164	7245	7381	7572	7735	7926	9015

casino 4970

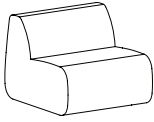

**Straight connector
Fully upholstered**

All necessary ganging brackets are included and pre-installed

SCS Indoor Advantage™ Gold and LEVEL® 2 certified. See terms and conditions for additional environmental information.

Seat Height	Arm Height	W	D	H	Fabric	Leather	Weight	Cubes/Qty
17"	-	32¾"	36¼"	28¼"	5.3 yds.	100.0'	76 lbs.	32.10'/1
432 mm	-	832 mm	921 mm	718 mm	4.8 m	9.3 sqm	34.5 kg	0.91 cu.

COM	COL	1	2	3	4	5	6	7	8	9	10	11
2097	2203	2592	2675	2722	2816	2898	2934	2993	3075	3146	3228	3699

casino 4979

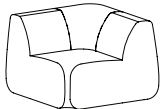

**Corner connector
Fully upholstered**

All necessary ganging brackets are included and pre-installed

SCS Indoor Advantage™ Gold and LEVEL® 2 certified. See terms and conditions for additional environmental information.

Seat Height	Arm Height	W	D	H	Fabric	Leather	Weight	Cubes/Qty
17"	-	37¾"	37¾"	28¼"	6.7 yds.	120.0'	113 lbs.	32.10'/1
432 mm	-	959 mm	959 mm	718 mm	6.1 m	11.1 sqm	51.3 kg	0.91 cu.

COM	COL	1	2	3	4	5	6	7	8	9	10	11
2899	3033	3525	3629	3689	3808	3912	3957	4031	4135	4225	4329	4924

casino 4980



**90° Curved connector
Fully upholstered**

All necessary ganging brackets are included and pre-installed

SCS Indoor Advantage™ Gold and LEVEL® 2 certified. See terms and conditions for additional environmental information.

Seat Height	Arm Height	W	D	H	Fabric	Leather	Weight	Cubes/Qty
17"	-	74½"	41¼"	28¼"	8.0 yds.	130.0'	95 lbs.	47.67'/1
432 mm	-	1892 mm	1048 mm	718 mm	7.3 m	12.1 sqm	43.1 kg	1.35 cu.

COM	COL	1	2	3	4	5	6	7	8	9	10	11
4186	4346	4933	5058	5129	5271	5395	5449	5538	5662	5769	5893	6604

casino 4981

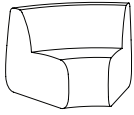

**45° Curved connector
FullC upholstered**

All necessary ganging brackets are included and pre-installed

SCS Indoor Advantage™ Gold and LEVEL® 2 certified. See terms and conditions for additional environmental information.

Seat Height	Arm Height	W	D	H	Fabric	Leather	Weight	Cubes/Qty
17"	-	40"	37 ⁵ / ₈ "	28 ¹ / ₄ "	5.3 yds.	100.0'	84 lbs.	32.10'/1
432 mm	-	1016 mm	956 mm	718 mm	4.8 m	9.3 sqm	38.1 kg	0.91 cu.

COM	COL	1	2	3	4	5	6	7	8	9	10	11
2418	2524	2913	2996	3043	3137	3219	3255	3314	3396	3467	3549	4020

casino 4982

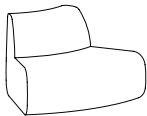

**45° Inverted curved connector
Fully upholstered**

All necessary ganging brackets are included and pre-installed

SCS Indoor Advantage™ Gold and LEVEL® 2 certified. See terms and conditions for additional environmental information.

Seat Height	Arm Height	W	D	H	Fabric	Leather	Weight	Cubes/Qty
17"	-	45 ¹ / ₄ "	38 ⁵ / ₈ "	28 ¹ / ₄ "	5.5 yds.	100.0'	80 lbs.	48.16'/1
432 mm	-	1162 mm	973 mm	718 mm	5.0 m	9.3 sqm	36.3 kg	1.37 cu.

COM	COL	1	2	3	4	5	6	7	8	9	10	11
2418	2528	2932	3017	3066	3164	3250	3286	3347	3433	3506	3592	4081

Cinema Seating System Specification Guide

Cinema is a modular seating product comprised of 15 unique modules which may be used interchangeably to create an unlimited number of configurations. It is fully upholstered with leveling non-marring glides. To select the modules that are appropriate for your application use the guide below.

When ordering multi-item configurations, please provide the total COM yardage from the same dye lot in a continuous roll(s). SCS Indoor Advantage™ Gold and LEVEL® 2 certified. See terms and conditions for additional environmental information.

Product Selection

A. Arm Modules

All Cinema configurations must include an arm module on each end of the configuration.

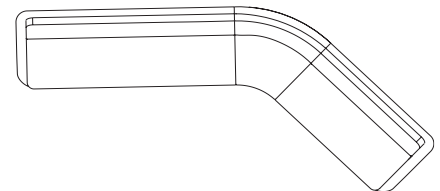
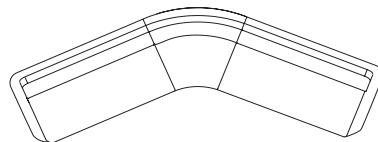
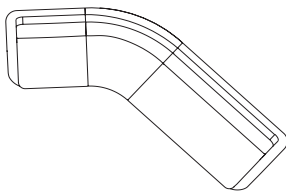
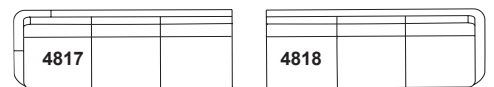
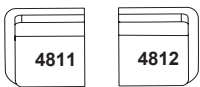

B. 45° Connecting Modules

Connecting modules are used in conjunction with arm modules.

Armless connecting modules may not be used at the end of a configuration or as a freestanding unit.

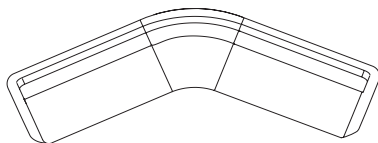

C. 67.5° Connecting Modules

Connecting modules are used in conjunction with arm modules.

Armless connecting modules may not be used at the end of a configuration or as a freestanding unit.

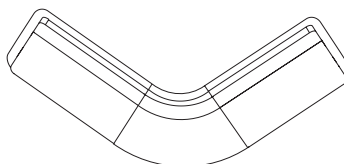
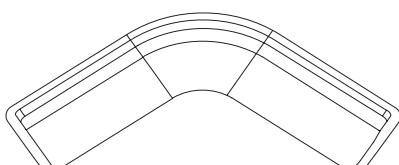

Cinema Seating System Specification Guide

D. 90° Connecting Arm Modules

Connecting modules are used in conjunction with arm modules.

Armless connecting modules may not be used at the end of a configuration or as a freestanding unit.

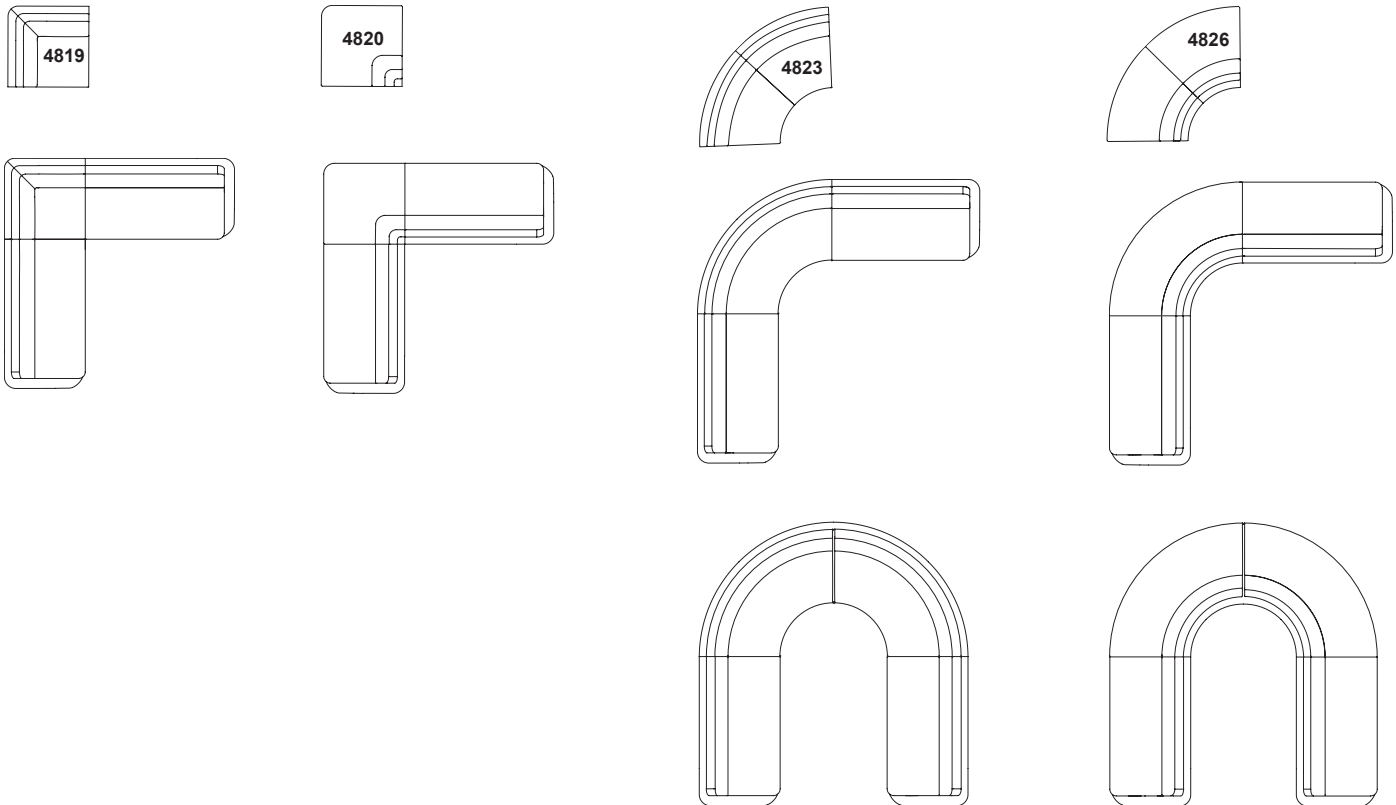

E. Straight Connecting Modules

Connecting modules are used in conjunction with arm modules.

Armless connecting modules may not be used at the end of a configuration or as a freestanding unit.

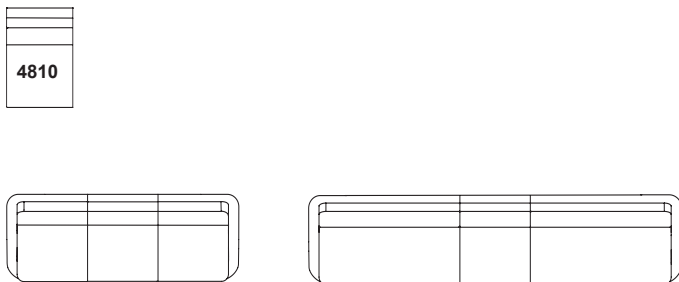

Cinema Seating System Overview

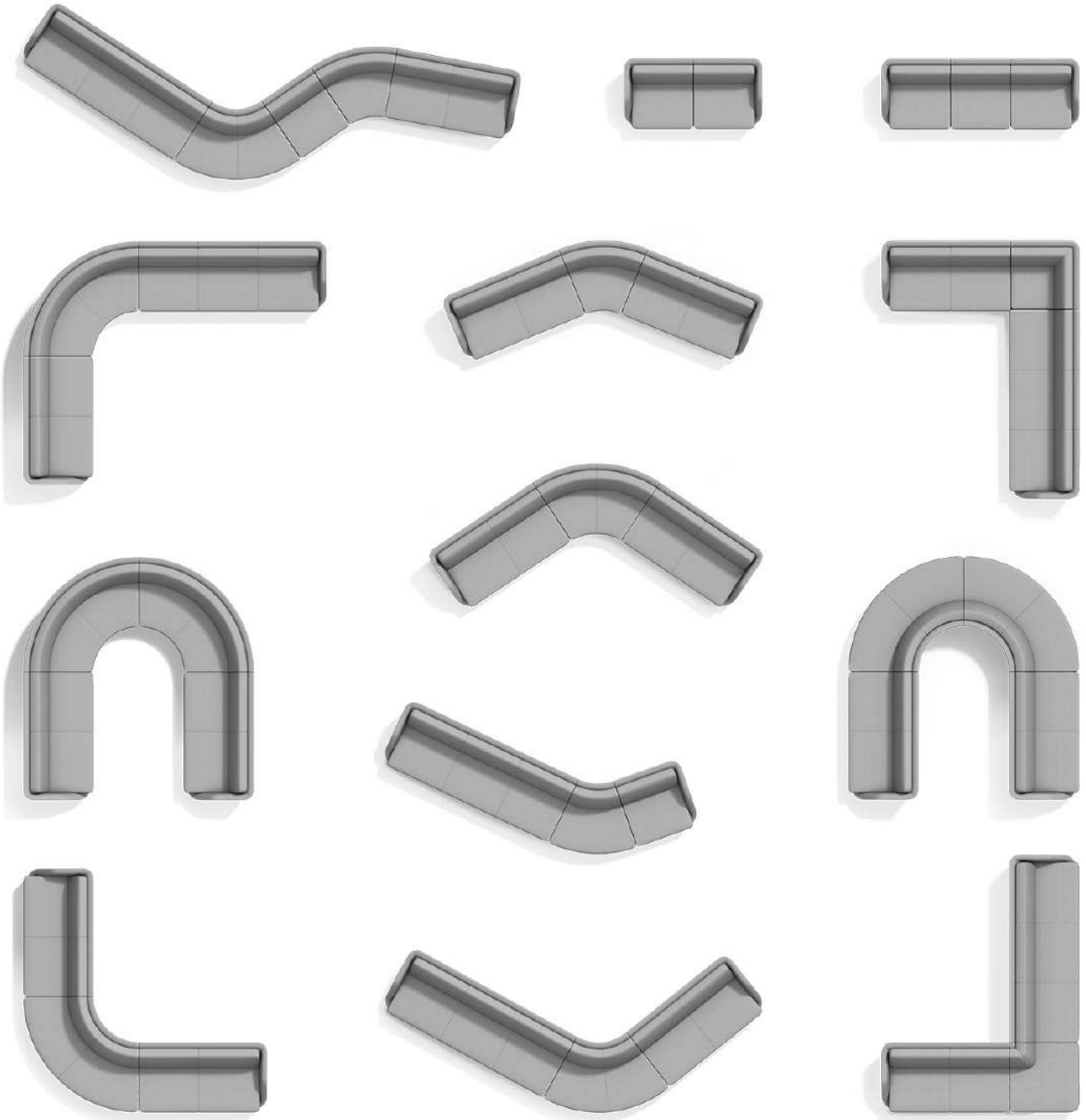

Cinema Seating System Sample Configurations

Skus Description

1

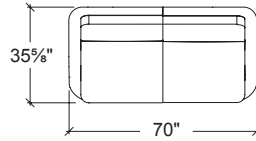
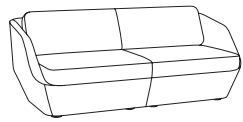

4811 Left Arm Facing Module
4812 Right Arm Facing Module

2

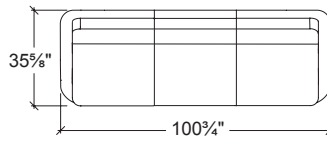
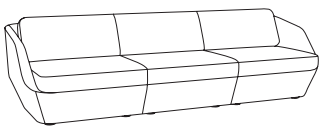

4811 Left Arm Facing Module
4810 Straight Connector
4812 Right Arm Facing Module

3

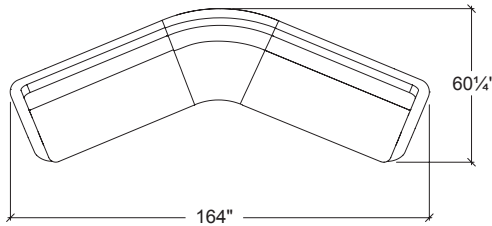
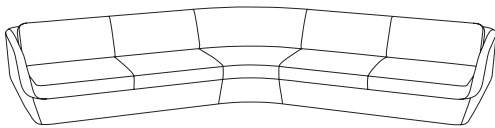

4815 Two-seat, Left Arm Facing Module
4821 45° Connector
4816 Two-seat, Right Arm Facing Module

4

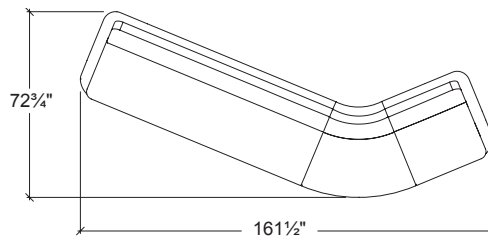
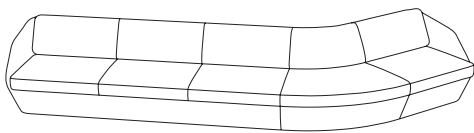

4817 Three-seat, Left Arm Facing Module
4824 45° Inverted Connector
4812 Single Seat, Right Arm Facing Module

5

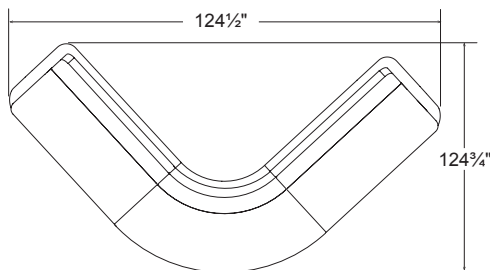
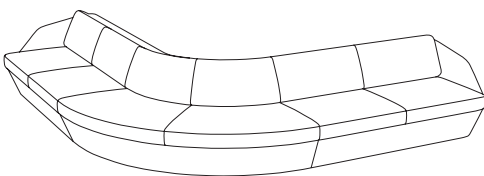



4815 Two-seat, Left Arm Facing Module
4826 90° Inverted Connector
4816 Two-seat, Right Arm Facing Module

Cinema Seating System Sample Configurations

	Sku	Description
6	<p>4817 Three-seat, Left Arm Facing Module 4825 67.5° Inverted Connector 4816 Two-seat, Right Arm Facing Module</p>	
7	<p>4815 Two-seat, Left Arm Facing Module 4822 67.5° Connector 4816 Two-seat, Right Arm Facing Module</p>	
8	<p>4815 Two-seat, Left Arm Facing Module 4820 Inverted Corner Connector 4818 Three-seat Right Arm Facing Module</p>	
9	<p>4815 Two-seat, Left Arm Facing Module 4819 Corner Connector 4818 Three-seat, Right Arm Facing Module</p>	
10	<p>4815 Two-seat, Left Arm Facing Module 4823 90° Connector 4818 Three-seat, Right Arm Facing Module</p>	

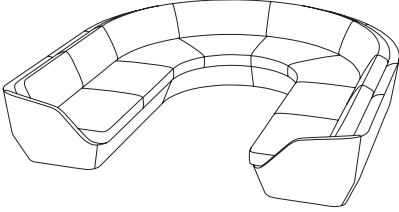
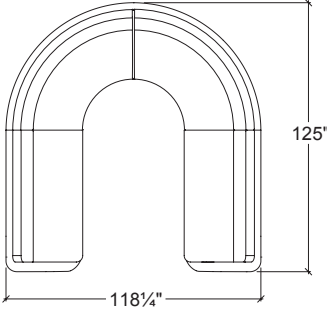
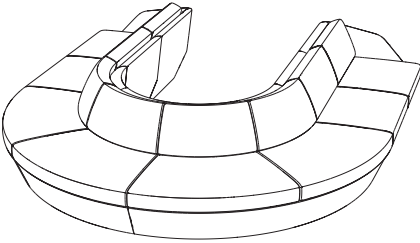
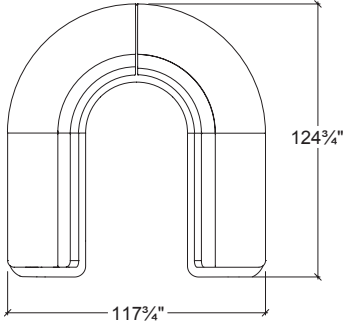
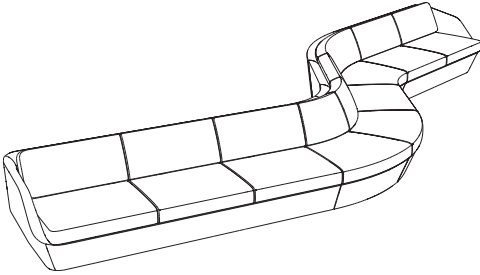
Cinema Seating System Sample Configurations

	Sku	Description
<p>11</p>  	<p>4815 4823 4816</p>	<p>Two-seat, Left Arm Facing Module 90° Connector (2) Two-seat, Right Arm Facing Module</p>
<p>12</p>  	<p>4816 4823 4815</p>	<p>Two-seat, Right Arm Facing Module 90° Inverted Connector (2) Two-seat, Left Arm Facing Module</p>
<p>13</p>  	<p>4817 4825 4810 4821 4816</p>	<p>Three-seat, Left Arm Facing Module 67.5° Inverted Connector Single Straight Connector 45° Connector Two-seat, Right Arm Facing Module</p>

cinema 4811

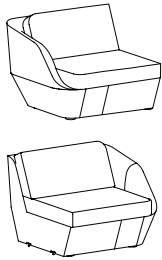

Fully upholstered

- 4811** Left arm facing module
- 4812** Right arm facing module

All necessary ganging brackets are included and pre-installed

When using a combination of fabrics or leathers, specify the application by designating the appropriate letter, shown below, on the purchase order. Yardage shown must be used.

See terms and conditions for contrasting upholstery upcharges.

- A) One fabric or leather for seat and inside back
yardage: 4.0 yds. leather: 70.0 sq. ft.
- B) One fabric or leather for outside back, outer shell, front panel and arms
yardage: 4.0 yds. leather: 70.0 sq. ft.

SCS Indoor Advantage™ Gold and LEVEL® 2 certified. See terms and conditions for additional environmental information.

Seat Height	Arm Height	W	D	H	Fabric	Leather	Weight	Cubes/Qty
17½"	23¼"	35½"	36"	29½"	8.0 yds.	140.0'	66 lbs.	32.10'/1
445 mm	591 mm	892 mm	914 mm	749 mm	7.3 m	13.0 sqm	30.0 kg	.91 cu.

COM	COL	1	2	3	4	5	6	7	8	9	10	11
2493	2653	3240	3365	3436	3578	3702	3756	3845	3969	4076	4200	4911

cinema 4815

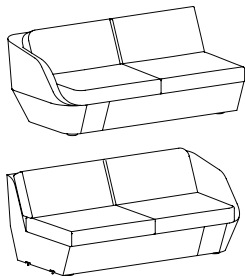

**Two-Seat
Fully upholstered**

- 4815** Left arm facing module
- 4816** Right arm facing module

All necessary ganging brackets are included and pre-installed

When using a combination of fabrics or leathers, specify the application by designating the appropriate letter, shown below, on the purchase order. Yardage shown must be used.

See terms and conditions for contrasting upholstery upcharges.

- A) One fabric or leather for seat and inside back
yardage: 6.0 yds. leather: 90.0 sq. ft.
- B) One fabric or leather for outside back, outer shell, front panel and arms
yardage: 8.5 yds. leather: 140.0 sq. ft.

SCS Indoor Advantage™ Gold and LEVEL® 2 certified. See terms and conditions for additional environmental information.

Seat Height	Arm Height	W	D	H	Fabric	Leather	Weight	Cubes/Qty
17½"	23¼"	65¼"	36"	29½"	14.3 yds.	235.0'	113 lbs.	68.33'/1
445 mm	591 mm	1670 mm	914 mm	749 mm	13.1 m	21.8 sqm	51.4 kg	1.93 cu.

COM	COL	1	2	3	4	5	6	7	8	9	10	11
4444	4730	5779	6002	6129	6383	6605	6701	6860	7082	7273	7495	8766

cinema 4817

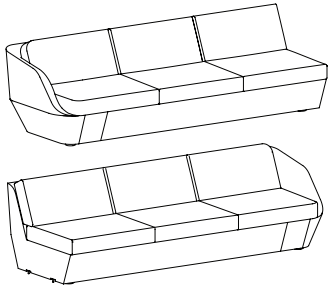

**Three-seat
Fully upholstered**

- 4817** Left arm facing module
- 4818** Right arm facing module

All necessary ganging brackets are included and pre-installed

When using a combination of fabrics or leathers, specify the application by designating the appropriate letter, shown below, on the purchase order. Yardage shown must be used.

See terms and conditions for contrasting upholstery upcharges.

- A) One fabric or leather for seat and inside back
yardage: 7.5 yds. leather: 125.0 sq. ft.
- B) One fabric or leather for outside back, outer shell, front panel and arms
yardage: 13.5 yds. leather: 220.0 sq. ft.

SCS Indoor Advantage™ Gold and LEVEL® 2 certified. See terms and conditions for additional environmental information.

Seat Height	Arm Height	W	D	H	Fabric	Leather	Weight	Cubes/Qty
17½"	23¼"	96¼"	36"	29½"	20.2 yds.	328.0'	149 lbs.	101.65'/1
445 mm	591 mm	2445 mm	914 mm	749 mm	18.5 m	30.4 sqm	67.7 kg	2.88 cu.

COM	COL	1	2	3	4	5	6	7	8	9	10	11
5508	5912	7394	7708	7888	8247	8561	8696	8920	9234	9504	9818	11613

cinema 4810

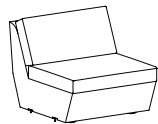

**Straight connector
Fully upholstered**

All necessary ganging brackets are included and pre-installed

When using a combination of fabrics or leathers, specify the application by designating the appropriate letter, shown below, on the purchase order. Yardage shown must be used.

See terms and conditions for contrasting upholstery upcharges.

- A) One fabric or leather for seat and inside back
yardage: 4.0 yds. leather: 70.0 sq. ft.
- B) One fabric or leather for outside back, outer shell and front panel
yardage: 3.0 yds. leather: 50.0 sq. ft.

SCS Indoor Advantage™ Gold and LEVEL® 2 certified. See terms and conditions for additional environmental information.

Seat Height	Arm Height	W	D	H	Fabric	Leather	Weight	Cubes/Qty
17½"	-	30⅝"	36"	29½"	6.9 yds.	130.0'	68 lbs.	32.10'/1
445 mm	-	778 mm	914 mm	749 mm	6.3 m	12.1 sqm	30.9 kg	.91 cu.

COM	COL	1	2	3	4	5	6	7	8	9	10	11
2137	2275	2781	2889	2950	3073	3180	3226	3303	3410	3502	3609	4223

cinema 4819

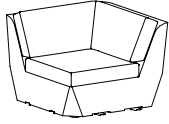

**Corner connector
Fully upholstered**

All necessary ganging brackets are included and pre-installed

When using a combination of fabrics or leathers, specify the application by designating the appropriate letter, shown below, on the purchase order. Yardage shown must be used.

See terms and conditions for contrasting upholstery upcharges.

- A) One fabric or leather for seat and inside back
yardage: 3.0 yds. leather: 50.0 sq. ft.
- B) One fabric or leather for outside back, outer shell, front panel and arms
yardage: 5.0 yds. leather: 85.0 sq. ft.

SCS Indoor Advantage™ Gold and LEVEL® 2 certified. See terms and conditions for additional environmental information.

Seat Height	Arm Height	W	D	H	Fabric	Leather	Weight	Cubes/Qty
17½"	-	35½"	36"	29½"	8.2 yds.	140.0'	69 lbs.	36.09/1
445 mm	-	905 mm	914 mm	749 mm	7.5 m	13.0 sqm	31.4 kg	1.04 cu.

COM	COL	1	2	3	4	5	6	7	8	9	10	11
3028	3192	3794	3921	3994	4140	4268	4322	4413	4541	4650	4778	5507

cinema 4820

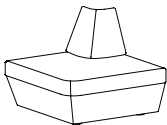

**Inverted corner connector
Fully upholstered**

All necessary ganging brackets are included and pre-installed

When using a combination of fabrics or leathers, specify the application by designating the appropriate letter, shown below, on the purchase order. Yardage shown must be used.

See terms and conditions for contrasting upholstery upcharges.

- A) One fabric or leather for seat and inside back
yardage: 5.0 yds. leather: 85.0 sq. ft.
- B) One fabric or leather for outside back, outer shell and front panel
yardage: 1.3 yds. leather: 25.0 sq. ft.

SCS Indoor Advantage™ Gold and LEVEL® 2 certified. See terms and conditions for additional environmental information.

Seat Height	Arm Height	W	D	H	Fabric	Leather	Weight	Cubes/Qty
17½"	-	35½"	36"	29½"	6.3 yds.	125.0'	66 lbs.	36.09/1
445 mm	-	905 mm	914 mm	749 mm	5.8 m	11.6 sqm	30.0 kg	1.04 cu.

COM	COL	1	2	3	4	5	6	7	8	9	10	11
3028	3154	3616	3714	3770	3882	3980	4022	4092	4190	4274	4372	4932

cinema 4821

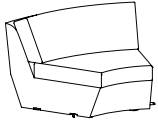

**45° Connector
Fully upholstered**

All necessary ganging brackets are included and pre-installed

When using a combination of fabrics or leathers, specify the application by designating the appropriate letter, shown below, on the purchase order. Yardage shown must be used.

See terms and conditions for contrasting upholstery upcharges.

- A) One fabric or leather for seat and inside back
yardage: 3.75 yds. leather: 61.0 sq. ft.
- B) One fabric or leather for outside back, outer shell and front panel
yardage: 3.75 yds. leather: 61.0 sq. ft.

SCS Indoor Advantage™ Gold and LEVEL® 2 certified. See terms and conditions for additional environmental information.

Seat Height	Arm Height	W	D	H	Fabric	Leather	Weight	Cubes/Qty
17½"	-	45¼"	37⅝"	29"	7.5 yds.	135.0'	85 lbs.	100.22/1
491 mm	-	1162 mm	956 mm	737 mm	6.9 m	12.5 sqm	38.6 kg	2.84 cu.

COM	COL	1	2	3	4	5	6	7	8	9	10	11
2493	2643	3193	3310	3377	3510	3627	3677	3760	3877	3977	4093	4760

cinema 4822

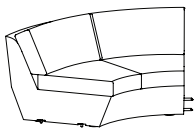

**67.5° Connector
Fully upholstered**

All necessary ganging brackets are included and pre-installed

When using a combination of fabrics or leathers, specify the application by designating the appropriate letter, shown below, on the purchase order. Yardage shown must be used.

See terms and conditions for contrasting upholstery upcharges.

- A) One fabric or leather for seat and inside back
yardage: 6.0 yds. leather: 100.0 sq. ft.
- B) One fabric or leather for outside back, outer shell and front panel
yardage: 7.0 yds. leather: 115.0 sq. ft.

SCS Indoor Advantage™ Gold and LEVEL® 2 certified. See terms and conditions for additional environmental information.

Seat Height	Arm Height	W	D	H	Fabric	Leather	Weight	Cubes/Qty
17½"	-	65¼"	39¼"	29"	13.1 yds.	220'	103 lbs.	100.22/1
491 mm	-	1657 mm	997 mm	737 mm	6.9 m	20.4 sqm	46.8 kg	2.84 cu.

COM	COL	1	2	3	4	5	6	7	8	9	10	11
3556	3818	4779	4983	5099	5332	5536	5623	5769	5973	6147	6351	7516

cinema 4823

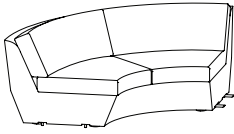

**90° Connector
Fully upholstered**

All necessary ganging brackets are included and pre-installed

When using a combination of fabrics or leathers, specify the application by designating the appropriate letter, shown below, on the purchase order. Yardage shown must be used.

See terms and conditions for contrasting upholstery upcharges.

- A) One fabric or leather for seat and inside back
yardage: 6.0 yds. leather: 100.0 sq. ft.
- B) One fabric or leather for outside back, outer shell and front panel
yardage: 10.2 yds. leather: 165.0 sq. ft.

SCS Indoor Advantage™ Gold and LEVEL® 2 certified. See terms and conditions for additional environmental information.

Seat Height	Arm Height	W	D	H	Fabric	Leather	Weight	Cubes/Qty
17½"	-	83¾"	42½"	29"	14.2 yds.	235.0'	125 lbs.	100.22/1
491 mm	-	2127 mm	1070 mm	737 mm	130 m	21.8 sqm	56.8 kg	2.84 cu.

COM	COL	1	2	3	4	5	6	7	8	9	10	11
4267	4551	5593	5814	5940	6192	6413	6508	6666	6887	7076	7297	8559

cinema 4824

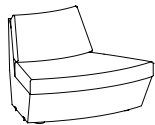

**45° Inverted connector
Fully upholstered**

All necessary ganging brackets are included and pre-installed

When using a combination of fabrics or leathers, specify the application by designating the appropriate letter, shown below, on the purchase order. Yardage shown must be used.

See terms and conditions for contrasting upholstery upcharges.

- A) One fabric or leather for seat and inside back
yardage: 4.0 yds. leather: 65.0 sq. ft.
- B) One fabric or leather for outside back, outer shell and front panel
yardage: 2.0 yds. leather: 35.0 sq. ft.

SCS Indoor Advantage™ Gold and LEVEL® 2 certified. See terms and conditions for additional environmental information.

Seat Height	Arm Height	W	D	H	Fabric	Leather	Weight	Cubes/Qty
17½"	-	45"	37½"	29"	6.0 yds.	110.0'	78 lbs.	100.22/1
491 mm	-	1143 mm	952 mm	737 mm	5.5 m	10.2 sqm	35.5 kg	2.84 cu.

COM	COL	1	2	3	4	5	6	7	8	9	10	11
2493	2613	3053	3147	3200	3307	3400	3440	3507	3600	3680	3773	4307

cinema 4825

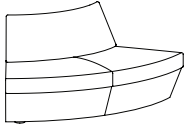

**67.5° Inverted connector
Fully upholstered**

All necessary ganging brackets are included and pre-installed

When using a combination of fabrics or leathers, specify the application by designating the appropriate letter, shown below, on the purchase order. Yardage shown must be used.

See terms and conditions for contrasting upholstery upcharges.

- A) One fabric or leather for seat and inside back
yardage: 7.6 yds. leather: 125.0 sq. ft.
- B) One fabric or leather for outside back, outer shell and front panel
yardage: 2.65 yds. leather: 45.0 sq. ft.

SCS Indoor Advantage™ Gold and LEVEL® 2 certified. See terms and conditions for additional environmental information.

Seat Height	Arm Height	W	D	H	Fabric	Leather	Weight	Cubes/Qty
17½"	-	65"	39¾"	29"	10.25 yds.	175.0'	96 lbs.	100.22'/1
491 mm	-	1651 mm	1010 mm	737 mm	9.4 m	16.3 sqm	43.6 kg	2.84 cu.

COM	COL	1	2	3	4	5	6	7	8	9	10	11
3556	3761	4513	4673	4764	4946	5105	5174	5288	5447	5584	5743	6654

cinema 4826

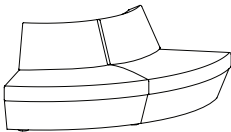

**90° Inverted connector
Fully upholstered**

All necessary ganging brackets are included and pre-installed

When using a combination of fabrics or leathers, specify the application by designating the appropriate letter, shown below, on the purchase order. Yardage shown must be used.

See terms and conditions for contrasting upholstery upcharges.

- A) One fabric or leather for seat and inside back
yardage: 10.0 yds. leather: 165.0 sq. ft.
- B) One fabric or leather for outside back, outer shell and front panel
yardage: 1.0 yds. leather: 17.0 sq. ft.

SCS Indoor Advantage™ Gold and LEVEL® 2 certified. See terms and conditions for additional environmental information.

Seat Height	Arm Height	W	D	H	Fabric	Leather	Weight	Cubes/Qty
17½"	-	83"	42½"	29"	11.0 yds.	185.0'	128 lbs.	100.22'/1
491 mm	-	2108 mm	1080 mm	737 mm	10.1 m	17.2 sqm	58.2 kg	2.84 cu.

COM	COL	1	2	3	4	5	6	7	8	9	10	11
4267	4487	5294	5465	5563	5759	5930	6003	6125	6296	6443	6614	7592

Code Seating System Specification Guide

Code is a seating system designed to provide privacy and create landscapes in open spaces. The system includes modular units which can be combined to create expanded sofas, U-Shaped and L-Shaped configurations. Individual freestanding privacy units are also available, as well as conventional chairs, settees and sofas. When ordering multi-item configurations, please provide the total COM yardage from the same dye lot in a continuous roll(s).

Visit BernhardtDesign.com for installation instructions as well as a library of 2D, 3D and Revit models. You may also contact your local sales representative or the Bernhardt Design corporate office for specification assistance. SCS Indoor Advantage™ Gold and LEVEL® 2 certified. See terms and conditions for additional environmental information.

Privacy walls are attached to the seat prior to shipping. **Verify that the assembled sku are within size requirements for delivery (elevators, hall intersections, stairwells, etc.).**

Seat Height Selection

Code units are available in two seat heights. Standard seat height is 16 $\frac{3}{8}$ ". Conference seat height is 18 $\frac{1}{2}$ ". Product numbers ending with the suffix C are Conference height.

Standard Seat Height

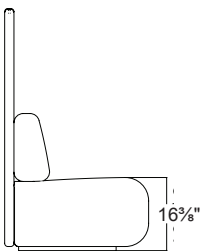

Conference Seat Height

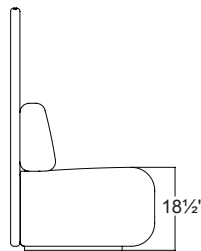

Wall Selection

Code privacy walls are available in two different models. Standard walls afford maximum privacy. Angled walls are lighter in appearance and provide improved seating access when used in a banquet application.

Standard Wall

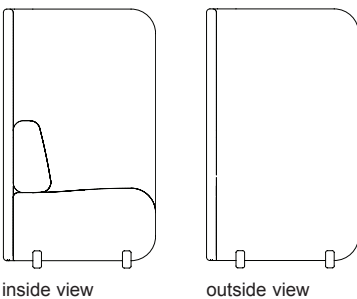

Angled Wall

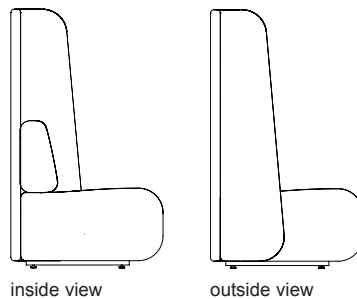

Conventional Lounge



2100

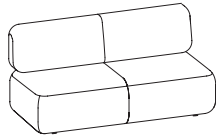

2105

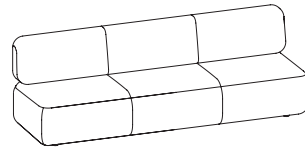

2107

Freestanding Privacy Lounge

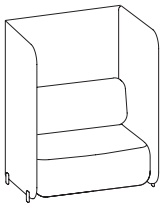

2140

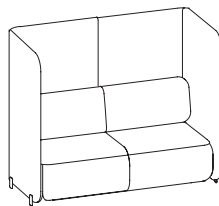

2145

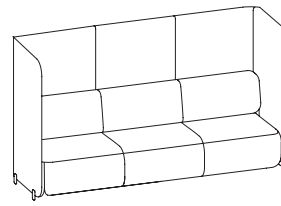

2147

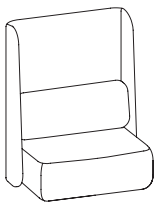

2130

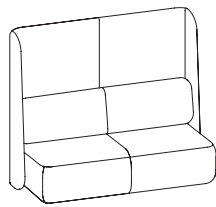

2135

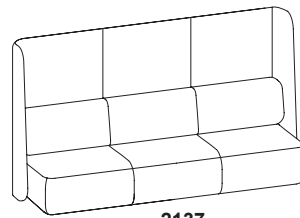

2137

Modular Privacy Lounge

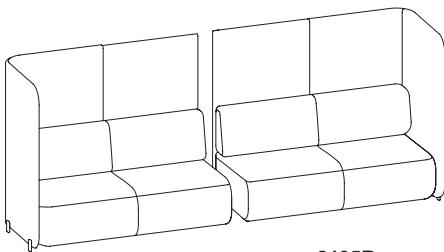

2195L

2195R

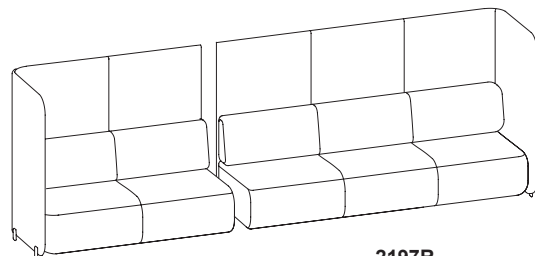

2197L

2197R

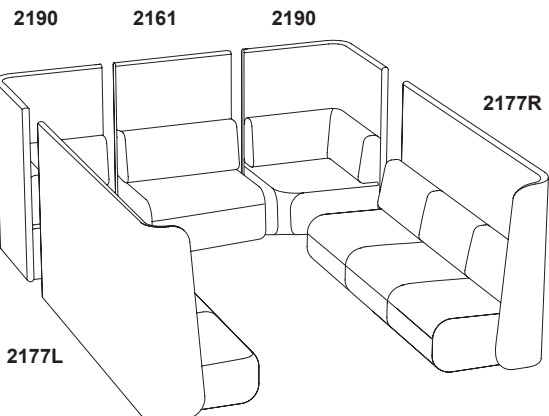

2177L

2177R

code 2191LC/2191RC

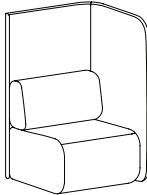
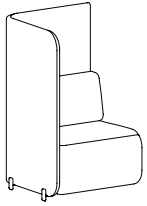

Conference seat height
Standard wall
Fully upholstered

2191LC Left facing
2191RC Right facing

Standard with welt around wall perimeter
Polished aluminum feet on walls
Attached privacy walls on 1½" plinth base with four adjustable non-marring glides
All necessary ganging brackets are included and pre-installed

When using a combination of fabrics, specify the application by designating the appropriate letter, shown below, on the purchase order. Yardage shown must be used.

See terms and conditions for contrasting upholstery upcharges.

- A) One fabric for seat
yardage: 4.25 yds.
- B) One fabric for wall
yardage: 6.5 yds.
- C) One fabric for back cushion
yardage: 2.5 yds.

SCS Indoor Advantage™ Gold and LEVEL® 2 certified. See terms and conditions for additional environmental information.

Seat Height	Seat Back Height	W	D	Wall Height	Fabric	Leather	Weight	Cubes/Qty
18½"	32½"	32¼"	31"	52¾"	11.25 yds.	-	150 lbs.	49.74/1
470 mm	816 mm	819 mm	787 mm	1340 mm	10.3 m	-	68.2 kg	1.41 cu.

COM	COL	1	2	3	4	5	6	7	8	9	10	11
4660	0	5710	5885	5985	6185	6360	6435	6560	6735	6885	7060	8060

code 2171LC/2171RC

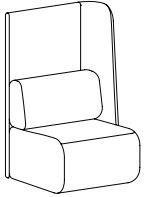
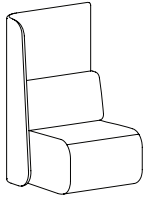

Conference seat height
Angled wall
Fully upholstered

2171LC Left facing
2171RC Right facing

Standard with welt around wall perimeter
Attached privacy walls on 1½" plinth base with adjustable non-marring glides
All necessary ganging brackets are included and pre-installed.

When using a combination of fabrics, specify the application by designating the appropriate letter, shown below, on the purchase order. Yardage shown must be used.

See terms and conditions for contrasting upholstery upcharges.

- A) One fabric for seat
yardage: 4.25 yds.
- B) One fabric for wall
yardage: 6.5 yds.
- C) One fabric for back cushion
yardage: 2.5 yds.

SCS Indoor Advantage™ Gold and LEVEL® 2 certified. See terms and conditions for additional environmental information.

Seat Height	Seat Back Height	W	D	Wall Height	Fabric	Leather	Weight	Cubes/Qty
18½"	32½"	32"	31"	52¾"	11.25 yds.	-	150 lbs.	49.74/1
470 mm	816 mm	813 mm	787 mm	1340 mm	10.3 m	-	68.2 kg	1.41 cu.

COM	COL	1	2	3	4	5	6	7	8	9	10	11
4315	0	5365	5540	5640	5840	6015	6090	6215	6390	6540	6715	7715

code 2195LC

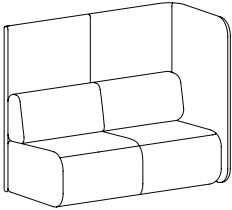
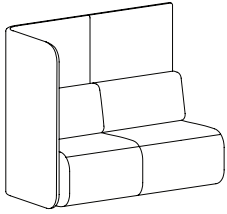

**Two-seat
Conference seat height
Standard wall
Fully upholstered**

**2195LC Left facing
2195RC Right facing**

Standard with welt around wall perimeter
Polished aluminum feet on walls
Attached privacy walls on 1½" plinth base with adjustable non-marring glides
All necessary ganging brackets are included and pre-installed

When using a combination of fabrics, specify the application by designating the appropriate letter, shown below, on the purchase order. Yardage shown must be used.

See terms and conditions for contrasting upholstery upcharges.

- A) One fabric for seat
yardage: 6.0 yds.
- B) One fabric for wall
yardage: 10.5 yds.
- C) One fabric for back cushion
yardage: 4.0 yds.

SCS Indoor Advantage™ Gold and LEVEL® 2 certified. See terms and conditions for additional environmental information.

Seat Height	Seat Back Height	W	D	Wall Height	Fabric	Leather	Weight	Cubes/Qty
18½"	32⅞"	62¼"	31"	52¾"	17.7 yds.	-	220 lbs.	84.58/1
470 mm	816 mm	1581 mm	787 mm	1340 mm	16.2 m	-	100.0 kg	2.40 cu.

COM	COL	1	2	3	4	5	6	7	8	9	10	11
5865	0	7517	7793	7950	8265	8540	8658	8855	9130	9366	9641	11215

code 2175LC/2175RC

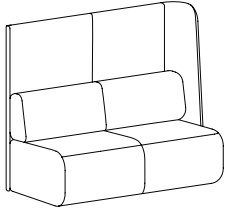
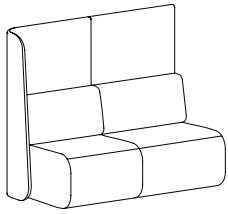

Two-seat
Conference seat height
Angled wall
Fully upholstered

2175LC Left facing
2175RC Right facing

Standard with welt around wall perimeter
Attached privacy walls on 1½" plinth base with adjustable non-marring glides
All necessary ganging brackets are included and pre-installed.

When using a combination of fabrics, specify the application by designating the appropriate letter, shown below, on the purchase order. Yardage shown must be used.

See terms and conditions for contrasting upholstery upcharges.

- A) One fabric for seat
yardage: 6.0 yds.
- B) One fabric for wall
yardage: 10.5 yds.
- C) One fabric for back cushion
yardage: 4.0 yds.

SCS Indoor Advantage™ Gold and LEVEL® 2 certified. See terms and conditions for additional environmental information.

Seat Height	Seat Back Height	W	D	Wall Height	Fabric	Leather	Weight	Cubes/Qty
18½"	32⅝"	62"	31"	52¼"	17.7 yds.	-	220 lbs.	84.58'/1
470 mm	816 mm	1575 mm	787 mm	1340 mm	16.2 m	-	100.0 kg	2.40 cu.

COM	COL	1	2	3	4	5	6	7	8	9	10	11
5520	0	7172	7448	7605	7920	8195	8313	8510	8785	9021	9296	10870

code 2197LC

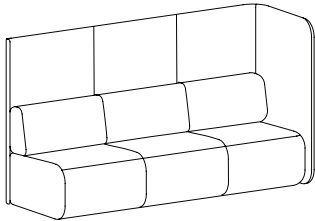
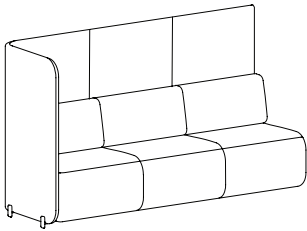

**Three-seat
Conference seat height
Standard wall
Fully upholstered**

**2197LC Left facing
2197RC Right facing**

Standard with welt around wall perimeter
Polished aluminum feet on walls
Attached privacy walls on 1½" plinth base with adjustable non-marring glides
All necessary ganging brackets are included and pre-installed

When using a combination of fabrics, specify the application by designating the appropriate letter, shown below, on the purchase order. Yardage shown must be used.

See terms and conditions for contrasting upholstery upcharges.

- A) One fabric for seat
yardage: 7.0 yds.
- B) One fabric for wall
yardage: 14.0 yds.
- C) One fabric for back cushion
yardage: 5.75 yds.

SCS Indoor Advantage™ Gold and LEVEL® 2 certified. See terms and conditions for additional environmental information.

Seat Height	Seat Back Height	W	D	Wall Height	Fabric	Leather	Weight	Cubes/Qty
18½"	32½"	92¼"	31"	52¼"	23.8 yds.	-	289 lbs.	123.25/1
470 mm	816 mm	2343 mm	787 mm	1340 mm	21.8 m	-	131.4 kg	3.50 cu.

COM	COL	1	2	3	4	5	6	7	8	9	10	11
8105	0	10327	10697	10909	11332	11702	11861	12125	12495	12813	13183	15298

code 2177LC/2177RC

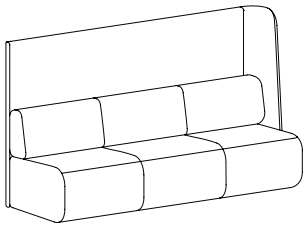
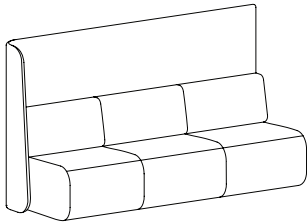

**Three-seat
Conference seat height
Angled wall
Fully upholstered**

**2177LC Left facing
2177RC Right facing**

Standard with welt around wall perimeter
Attached facing privacy walls on 1½" plinth base with adjustable non-marring glides
All necessary ganging brackets are included and pre-installed

When using a combination of fabrics, specify the application by designating the appropriate letter, shown below, on the purchase order. Yardage shown must be used.

See terms and conditions for contrasting upholstery upcharges.

- A) One fabric for seat
yardage: 7.0 yds.
- B) One fabric for wall
yardage: 14.0 yds.
- C) One fabric for back cushion
yardage: 5.75 yds.

SCS Indoor Advantage™ Gold and LEVEL® 2 certified. See terms and conditions for additional environmental information.

Seat Height	Seat Back Height	W	D	Wall Height	Fabric	Leather	Weight	Cubes/Qty
18½"	32½"	92"	31"	52¾"	23.8 yds.	-	289 lbs.	123.25/1
470 mm	816 mm	2337 mm	787 mm	1340 mm	21.8 m	-	131.4 kg	3.50 cu.

COM	COL	1	2	3	4	5	6	7	8	9	10	11
7760	0	9982	10352	10564	10987	11357	11516	11780	12150	12468	12838	14953

code 2190C

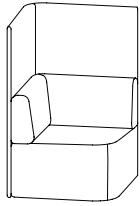

Conference seat height
Corner wall
Fully upholstered

Standard with welt around wall perimeter
Attached privacy walls on 1½" plinth base with adjustable non-marring glides
All necessary ganging brackets are included and pre-installed.

Corner Wall is used in conjunction with other modules to create shaped configurations. May not be used as a freestanding unit or at the end of a modular configuration.

When using a combination of fabrics, specify the application by designating the appropriate letter, shown below, on the purchase order. Yardage shown must be used.

See terms and conditions for contrasting upholstery upcharges.

- A) One fabric for seat
yardage: 4.75 yds.
- B) One fabric for wall
yardage: 7.5 yds.
- C) One fabric for back cushion
yardage: 4.0 yds.

SCS Indoor Advantage™ Gold and LEVEL® 2 certified. See terms and conditions for additional environmental information.

Seat Height	Seat Back Height	W	D	Wall Height	Fabric	Leather	Weight	Cubes/Qty
18½"	816 mm	33"	33"	52½"	12.4 yds.	-	134 lbs.	49.74/1
470 mm	816 mm	838 mm	838 mm	1340 mm	11.3 m	-	60.9 kg	1.41 cu.

COM	COL	1	2	3	4	5	6	7	8	9	10	11
4660	0	5818	6011	6121	6341	6534	6617	6755	6948	7113	7306	8408

code 2160C

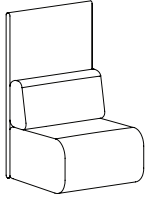

Conference seat height
Connecting wall
Fully upholstered

Standard with welt around wall perimeter
Attached privacy walls on 1½" plinth base with adjustable non-marring glides
All necessary ganging brackets are included and pre-installed

Connecting Wall is used in conjunction with other modules to create shaped configurations. May not be used as a freestanding unit or at the end of a modular configuration.

When using a combination of fabrics, specify the application by designating the appropriate letter, shown below, on the purchase order. Yardage shown must be used.

See terms and conditions for contrasting upholstery upcharges.

- A) One fabric for seat
yardage: 4.25 yds.
- B) One fabric for wall
yardage: 3.5 yds.
- C) One fabric for back cushion
yardage: 2.5 yds.

SCS Indoor Advantage™ Gold and LEVEL® 2 certified. See terms and conditions for additional environmental information.

Seat Height	Seat Back Height	W	D	Wall Height	Fabric	Leather	Weight	Cubes/Qty
18½"	32½"	30"	31"	52½"	8.75 yds.	-	141 lbs.	49.74'/1
470 mm	816 mm	762 mm	787 mm	1340 mm	8.0 m	-	64.1 kg	1.41 cu.

COM	COL	1	2	3	4	5	6	7	8	9	10	11
2765	0	3582	3718	3796	3952	4088	4146	4243	4379	4496	4632	5410

code 2161C

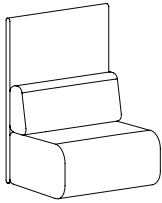

Conference seat height
Connecting wall
Fully upholstered

Standard with welt around wall perimeter
Attached privacy walls on 1½" plinth base with adjustable non-marring glides
All necessary ganging brackets are included and pre-installed

Connecting Wall is used in conjunction with other modules to create shaped configurations. May not be used as a freestanding unit or at the end of a modular configuration.

When using a combination of fabrics, specify the application by designating the appropriate letter, shown below, on the purchase order. Yardage shown must be used.

See terms and conditions for contrasting upholstery upcharges.

- A) One fabric for seat
yardage: 4.25 yds.
- B) One fabric for wall
yardage: 3.5 yds.
- C) One fabric for back cushion
yardage: 2.5 yds.

SCS Indoor Advantage™ Gold and LEVEL® 2 certified. See terms and conditions for additional environmental information.

Seat Height	Seat Back Height	W	D	Wall Height	Fabric	Leather	Weight	Cubes/Qty
18½"	32½"	36"	31"	52½"	8.75 yds.	-	141 lbs.	49.74'/1
470 mm	816 mm	914 mm	787 mm	1340 mm	8.0 m	-	64.1 kg	1.41 cu.

COM	COL	1	2	3	4	5	6	7	8	9	10	11
2936	0	3753	3889	3967	4123	4259	4317	4414	4550	4667	4803	5581

code 2165C

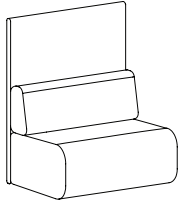

Conference seat height
Connecting wall
Fully upholstered

Standard with welt around wall perimeter
Attached privacy walls on 1½" plinth base with adjustable non-marring glides
All necessary ganging brackets are included and pre-installed

Connecting Wall is used in conjunction with other modules to create shaped configurations. May not be used as a freestanding unit or at the end of a modular configuration.

When using a combination of fabrics, specify the application by designating the appropriate letter, shown below, on the purchase order. Yardage shown must be used.

See terms and conditions for contrasting upholstery upcharges.

- A) One fabric for seat
yardage: 4.25 yds.
- B) One fabric for wall
yardage: 3.5 yds.
- C) One fabric for back cushion
yardage: 2.5 yds..

SCS Indoor Advantage™ Gold and LEVEL® 2 certified. See terms and conditions for additional environmental information.

Seat Height	Seat Back Height	W	D	Wall Height	Fabric	Leather	Weight	Cubes/Qty
18½"	32¼"	42"	31"	52¾"	8.75 yds.	-	158 lbs.	55.58/1
470 mm	816 mm	838 mm	787 mm	1340 mm	8.0 m	-	71.8 kg	1.57 cu.

COM	COL	1	2	3	4	5	6	7	8	9	10	11
3110	0	3927	4063	4141	4297	4433	4491	4588	4724	4841	4977	5755

code 2191L/2191R

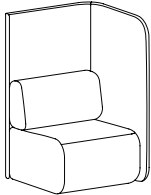
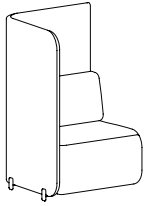

Standard seat height
Standard wall
Fully upholstered

2191L Left facing
2191R Right facing

Standard with welt around wall perimeter
Polished aluminum feet on walls
Attached privacy walls on 1½" plinth base with adjustable non-marring glides
All necessary ganging brackets are included and pre-installed.

When using a combination of fabrics, specify the application by designating the appropriate letter, shown below, on the purchase order. Yardage shown must be used.

See terms and conditions for contrasting upholstery upcharges.

- A) One fabric for seat
yardage: 4.25 yds.
- B) One fabric for wall
yardage: 6.5 yds.
- C) One fabric for back cushion
yardage: 2.5 yds.

SCS Indoor Advantage™ Gold and LEVEL® 2 certified. See terms and conditions for additional environmental information.

Seat Height	Seat Back Height	W	D	Wall Height	Fabric	Leather	Weight	Cubes/Qty
16¾"	30"	32¼"	31"	52¾"	11.25 yds.	-	150 lbs.	49.74/1
416 mm	762 mm	819 mm	787 mm	1340 mm	10.3 m	-	68.2 kg	1.41 cu.

COM	COL	1	2	3	4	5	6	7	8	9	10	11
4660	0	5710	5885	5985	6185	6360	6435	6560	6735	6885	7060	8060

code 2171L/2171R

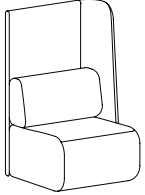
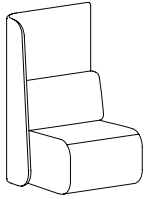

Standard seat height
Angled wall
Fully upholstered

2171L Left facing
2171R Right facing

Standard with welt around wall perimeter
Attached privacy walls on 1½" plinth base with adjustable non-marring glides
All necessary ganging brackets are included and pre-installed

When using a combination of fabrics, specify the application by designating the appropriate letter, shown below, on the purchase order. Yardage shown must be used.

See terms and conditions for contrasting upholstery upcharges.

- A) One fabric for seat
yardage: 4.25 yds.
- B) One fabric for wall
yardage: 6.5 yds.
- C) One fabric for back cushion
yardage: 2.5 yds.

SCS Indoor Advantage™ Gold and LEVEL® 2 certified. See terms and conditions for additional environmental information.

Seat Height	Seat Back Height	W	D	Wall Height	Fabric	Leather	Weight	Cubes/Qty
16¾"	30"	32"	31"	52¾"	11.25 yds.	-	150 lbs.	49.74/1
416 mm	762 mm	813 mm	787 mm	52¾"	10.3 m	-	68.2 kg	1.41 cu.

COM	COL	1	2	3	4	5	6	7	8	9	10	11
4315	0	5365	5540	5640	5840	6015	6090	6215	6390	6540	6715	7715

code 2195L/2195R

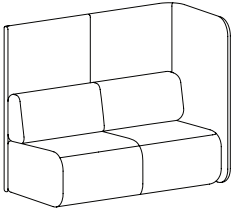
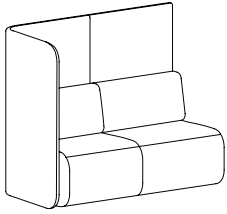

Two-seat
Standard seat height
Standard wall
Fully upholstered

2195L Left facing
2195R Right facing

Standard with welt around wall perimeter
Polished aluminum feet on walls
Attached privacy walls on 1½" plinth base with adjustable non-marring glides
All necessary ganging brackets are included and pre-installed

When using a combination of fabrics, specify the application by designating the appropriate letter, shown below, on the purchase order. Yardage shown must be used.

See terms and conditions for contrasting upholstery upcharges..

- A) One fabric for seat
yardage: 6.0 yds.
- B) One fabric for wall
yardage: 10.5 yds.
- C) One fabric for back cushion
yardage: 4.0 yds.

SCS Indoor Advantage™ Gold and LEVEL® 2 certified. See terms and conditions for additional environmental information.

Seat Height	Seat Back Height	W	D	Wall Height	Fabric	Leather	Weight	Cubes/Qty
16¾"	30"	62½"	31"	52¾"	17.7 yds.	-	220 lbs.	84.58/1
416 mm	762 mm	1581 mm	787 mm	1340 mm	16.2 m	-	100.0 kg	2.40 cu.

COM	COL	1	2	3	4	5	6	7	8	9	10	11
5865	0	7517	7793	7950	8265	8540	8658	8855	9130	9366	9641	11215

code 2175L/2175R

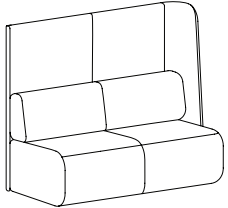
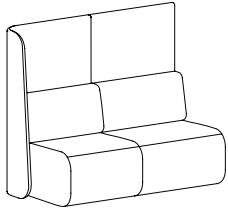

Two-seat
Standard seat height
Angled wall
Fully upholstered

2175L Left facing
2175R Right facing

Standard with welt around wall perimeter
Attached back and right facing privacy walls on 1½" plinth base with four adjustable non-marring glides
All necessary ganging brackets are included and pre-installed.

When using a combination of fabrics, specify the application by designating the appropriate letter, shown below, on the purchase order. Yardage shown must be used.

See terms and conditions for contrasting upholstery upcharges.

- A) One fabric for seat
yardage: 6.0 yds.
- B) One fabric for wall
yardage: 10.5 yds.
- C) One fabric for back cushion
yardage: 4.0 yds.

SCS Indoor Advantage™ Gold and LEVEL® 2 certified. See terms and conditions for additional environmental information.

Seat Height	Seat Back Height	W	D	Wall Height	Fabric	Leather	Weight	Cubes/Qty
16¾"	30"	62"	31"	52¾"	17.7 yds.	-	220 lbs.	84.58/1
416 mm	762 mm	1575 mm	787 mm	52¾"	16.2 m	-	100.0 kg	2.40 cu.

COM	COL	1	2	3	4	5	6	7	8	9	10	11
5520	0	7172	7448	7605	7920	8195	8313	8510	8785	9021	9296	10870

code 2197L/2197R

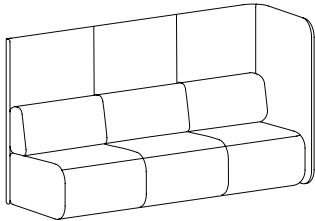
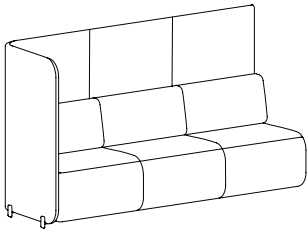

Three-seat
Standard seat height
Standard wall
Fully upholstered

2197L Left facing
2197R Right facing

Standard with welt around wall perimeter
Polished aluminum feet on walls
Attached back and right facing privacy walls on 1½" plinth base with four adjustable non-marring glides
All necessary ganging brackets are included and pre-installed

When using a combination of fabrics, specify the application by designating the appropriate letter, shown below, on the purchase order. Yardage shown must be used.

See terms and conditions for contrasting upholstery upcharges.

- A) One fabric for seat
yardage: 7.0 yds.
- B) One fabric for wall
yardage: 14.0 yds.
- C) One fabric for back cushion
yardage: 5.75 yds.

SCS Indoor Advantage™ Gold and LEVEL® 2 certified. See terms and conditions for additional environmental information.

Seat Height	Seat Back Height	W	D	Wall Height	Fabric	Leather	Weight	Cubes/Qty
16¾"	30"	92¼"	31"	52¾"	23.8 yds.	-	289 lbs.	123.25/1
416 mm	762 mm	2343 mm	787 mm	1340 mm	21.8 m	-	131.4kg	3.50 cu.

COM	COL	1	2	3	4	5	6	7	8	9	10	11
8105	0	10327	10697	10909	11332	11702	11861	12125	12495	12813	13183	15298

code 2177L/2177R

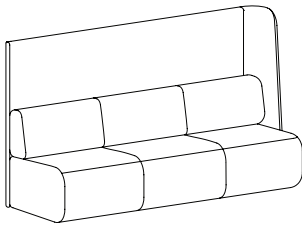
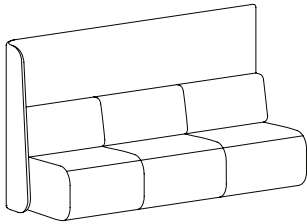

Three-seat
Standard seat height
Angled wall
Fully upholstered

2177L Left facing
2177R Right facing

Standard with welt around wall perimeter
Attached privacy walls on 1½" plinth base with adjustable non-marring glides
All necessary ganging brackets are included and pre-installed

When using a combination of fabrics, specify the application by designating the appropriate letter, shown below, on the purchase order. Yardage shown must be used.

See terms and conditions for contrasting upholstery upcharges.

- A) One fabric for seat
yardage: 7.0 yds.
- B) One fabric for wall
yardage: 14.0 yds.
- C) One fabric for back cushion
yardage: 5.75 yds.

SCS Indoor Advantage™ Gold and LEVEL® 2 certified. See terms and conditions for additional environmental information.

Seat Height	Seat Back Height	W	D	Wall Height	Fabric	Leather	Weight	Cubes/Qty
16¾"	30"	92"	31"	52¾"	23.8 yds.	-	289 lbs.	123.25/1
16¾"	762 mm	2337 mm	787 mm	1340 mm	21.8 m	-	131.4kg	3.50 cu.

COM	COL	1	2	3	4	5	6	7	8	9	10	11
7760	0	9982	10352	10564	10987	11357	11516	11780	12150	12468	12838	14953

code 2190

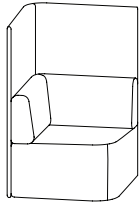

Standard seat height
Corner wall
Fully upholstered

Standard with welt around wall perimeter
Attached privacy walls on 1½" plinth base with adjustable non-marring glides
All necessary ganging brackets are included and pre-installed

Corner Wall is used in conjunction with other modules to create shaped configurations. May not be used as a freestanding unit or at the end of a modular configuration.

When using a combination of fabrics, specify the application by designating the appropriate letter, shown below, on the purchase order. Yardage shown must be used.

See terms and conditions for contrasting upholstery upcharges.

- A) One fabric for seat
yardage: 4.75 yds.
- B) One fabric for wall
yardage: 7.5 yds.
- C) One fabric for back cushion
yardage: 4.0 yds.

SCS Indoor Advantage™ Gold and LEVEL® 2 certified. See terms and conditions for additional environmental information.

Seat Height	Seat Back Height	W	D	Wall Height	Fabric	Leather	Weight	Cubes/Qty
16¾"	30"	33"	33"	52¾"	12.4 yds.	-	134 lbs.	49.74'/1
416 mm	762 mm	838 mm	838 mm	1340 mm	11.3 m	-	60.9 kg	1.41 cu.

COM	COL	1	2	3	4	5	6	7	8	9	10	11
4660	0	5818	6011	6121	6341	6534	6617	6755	6948	7113	7306	8408

code 2160

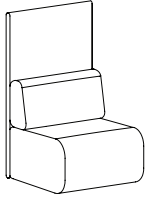

Standard seat height
Connecting wall
Fully upholstered

Standard with welt around wall perimeter
Attached privacy walls on 1½" plinth base with adjustable non-marring glides
All necessary ganging brackets are included and pre-installed

Connecting wall is used in conjunction with other modules to create shaped configurations. May not be used as a freestanding unit or at the end of a modular configuration.

When using a combination of fabrics, specify the application by designating the appropriate letter, shown below, on the purchase order. Yardage shown must be used.

See terms and conditions for contrasting upholstery upcharges.

- A) One fabric for seat
yardage: 4.25 yds.
- B) One fabric for wall
yardage: 3.5 yds.
- C) One fabric for back cushion
yardage: 2.5 yds.

SCS Indoor Advantage™ Gold and LEVEL® 2 certified. See terms and conditions for additional environmental information.

Seat Height	Seat Back Height	W	D	Wall Height	Fabric	Leather	Weight	Cubes/Qty
16¾"	30"	30"	31"	52¾"	8.75 yds.	-	141 lbs.	49.74'/1
416 mm	762 mm	762 mm	787 mm	1340 mm	8.0 m	-	64.1 kg	1.41 cu.

COM	COL	1	2	3	4	5	6	7	8	9	10	11
2765	0	3582	3718	3796	3952	4088	4146	4243	4379	4496	4632	5410

code 2161

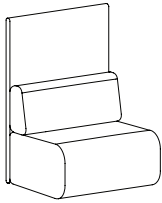

Standard seat height
Connecting wall
Fully upholstered

Standard with welt around wall perimeter
Attached privacy walls on 1½" plinth base with adjustable non-marring glides
All necessary ganging brackets are included and pre-installed

Connecting wall is used in conjunction with other modules to create shaped configurations. May not be used as a freestanding unit or at the end of a modular configuration.

When using a combination of fabrics, specify the application by designating the appropriate letter, shown below, on the purchase order. Yardage shown must be used.

See terms and conditions for contrasting upholstery upcharges.

- A) One fabric for seat
yardage: 4.25 yds.
- B) One fabric for wall
yardage: 3.5 yds.
- C) One fabric for back cushion
yardage: 2.5 yds.

SCS Indoor Advantage™ Gold and LEVEL® 2 certified. See terms and conditions for additional environmental information.

Seat Height	Seat Back Height	W	D	Wall Height	Fabric	Leather	Weight	Cubes/Qty
16¾"	30"	36"	31"	52¾"	8.75 yds.		141 lbs.	49.74'/1
416 mm	762 mm	914 mm	787 mm	1340 mm	8.0 m	-	64.1 kg	1.41 cu.

COM	COL	1	2	3	4	5	6	7	8	9	10	11
2936	0	3753	3889	3967	4123	4259	4317	4414	4550	4667	4803	5581

code 2165

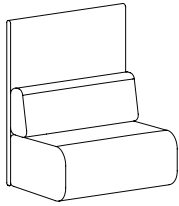

Standard seat height
Connecting wall
Fully upholstered

Standard with welt around wall perimeter
Attached privacy walls on 1½" plinth base with adjustable non-marring glides
All necessary ganging brackets are included and pre-installed

Connecting wall is used in conjunction with other modules to create shaped configurations. May not be used as a freestanding unit or at the end of a modular configuration.

When using a combination of fabrics, specify the application by designating the appropriate letter, shown below, on the purchase order. Yardage shown must be used.

See terms and conditions for contrasting upholstery upcharges.

- A) One fabric for seat
yardage: 4.25 yds.
- B) One fabric for wall
yardage: 3.5 yds.
- C) One fabric for back cushion
yardage: 2.5 yds.

SCS Indoor Advantage™ Gold and LEVEL® 2 certified. See terms and conditions for additional environmental information.

Seat Height	Seat Back Height	W	D	Wall Height	Fabric	Leather	Weight	Cubes/Qty
16¾"	30"	42"	31"	52¾"	8.75 yds.	-	158.0 lbs.	84.58/1
416 mm	762 mm	1067 mm	787 mm	1340 mm	8.0 m	-	71.8 kg	2.4 cu.

COM	COL	1	2	3	4	5	6	7	8	9	10	11
3110	0	3927	4063	4141	4297	4433	4491	4588	4724	4841	4977	5755

Colours Seating System Specification Guide

Colours is a modular seating product comprised of 13 unique modules which may be used interchangeably to create an unlimited number of configurations. To select the modules that are appropriate for your application use the guide below.

Colours is fully upholstered with saddle stitch detailing. Fabric and vinyl applications will be railroaded. Leather will incorporate saddle stitch seams on the top panel. When ordering multi-item configurations, please provide the total COM yardage from the same dye lot in a continuous roll(s). Non-marring glides with vinyl sleeves prevent the units from sliding on smooth surfaces.

Due to the organic shapes, the dimensions can vary depending on the orientation of the product. Therefore, a maximum dimension is provided in the price list information. The 2D models provide dimensioned drawings of Colours. Consult Bernhardtdesign.com for a complete library of 2D, 3D and Revit models.

SCS Indoor Advantage™ Gold and LEVEL® 2 certified. See terms and conditions for additional environmental information. Contact your local sales representative or the Bernhardt Design corporate office for specification assistance.

Connecting Modules

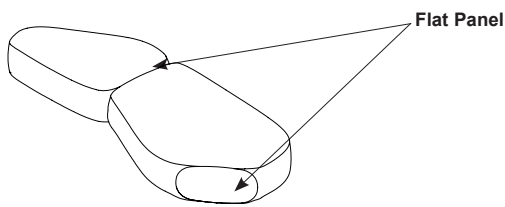

Non-Connecting Modules

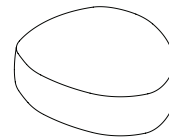

Non-Connecting Modules

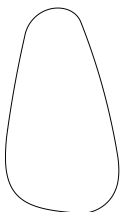

Colours 1
4831

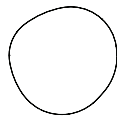

Colours 13
4843

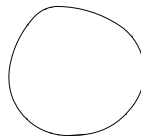

Colours 2
4832

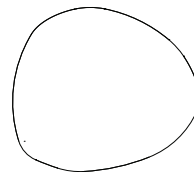

Colours 3
4833

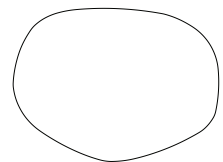

Colours 4
4834

Connecting Modules

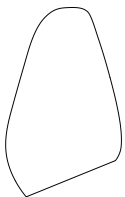

Colours 5
4835



Colours 6
4836

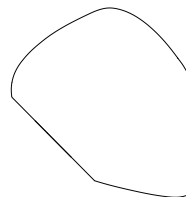

Colours 7
4837

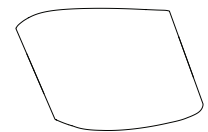

Colours 8
4838

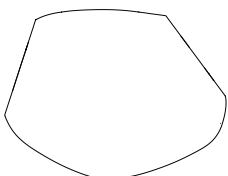

Colours 9
4839

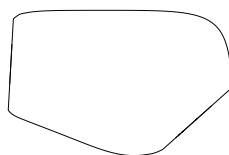

Colours 10
4840

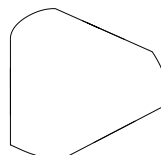

Colours 11
4841

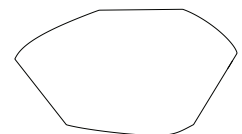

Colours 12
4842

Colours - Fabric Application

Fabric covers incorporate seamless top panels. Fabric will be Railroaded on the top panel for all skus. Striped or plaid fabrics and certain patterns with distinct direction are not suitable for application. Solids, textures and leathers are recommended.

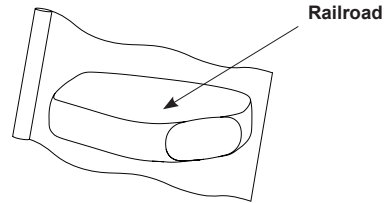
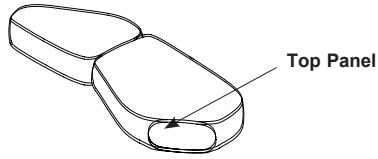

Colours - Leather Application

Leather covers incorporate saddle stitch seams on the top panel. See diagrams below, noting seam locations for each sku.

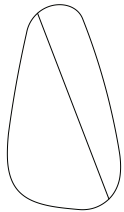
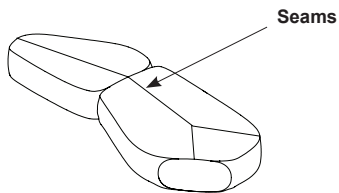

Colours 1
4831

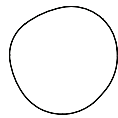

Colours 13
4843
No Seam

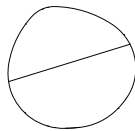

Colours 2
4832

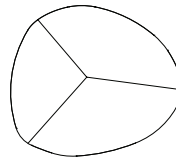

Colours 3
4833

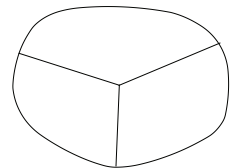

Colours 4
4834

Connecting Modules

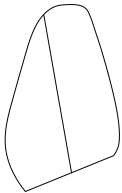

Colours 5
4835



Colours 6
4836

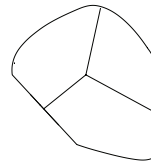

Colours 7
4837

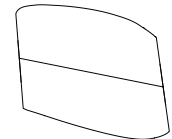

Colours 8
4838

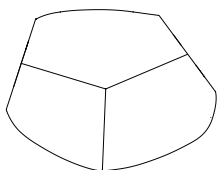

Colours 9
4839

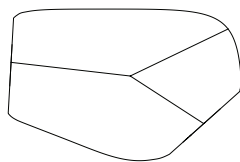

Colours 10
4840

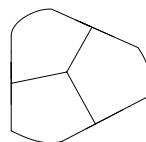



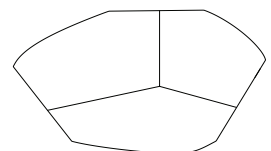

Colours 11
4841



Colours 12
4842

Colours Seating System Sample Configurations

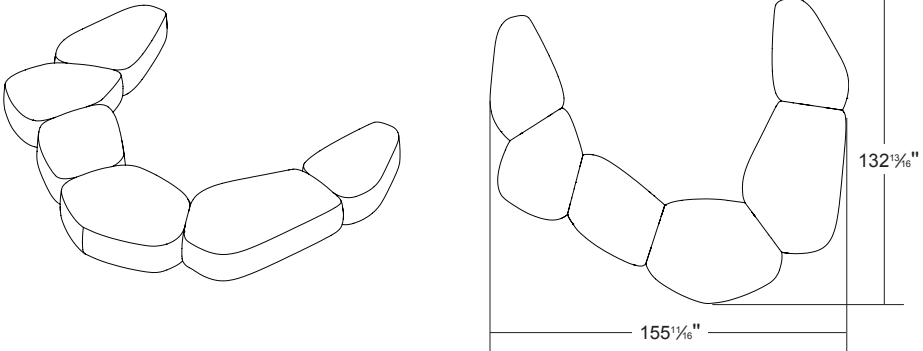
	Sku	Description
<p>1</p> 	4835	Colours 5 (2)
<p>2</p> 	4836 4840	Colours 6 Colours 10
<p>3</p> 	4837 4839 4836	Colours 7 Colours 9 Colours 6
<p>4</p> 	4835 4841 4835 4836	Colours 5 Colours 11 Colours 5 Colours 6
<p>5</p> 	4835 4837 4838 4839 4840 4836	Colours 5 Colours 7 Colours 8 Colours 9 Colours 10 Colours 6

Colours Seating System Sample Configurations

6	Sku Description
	<p>4835 Colours 5 4839 Colours 9 4840 Colours 10 4835 Colours 5</p>
<p data-bbox="86 672 110 703">7</p>	<p>4835 Colours 5 4838 Colours 8 4842 Colours 12 4838 Colours 8 4835 Colours 5 4838 Colours 8 4836 Colours 6</p>
<p data-bbox="86 1134 110 1165">8</p>	<p>4836 Colours 6 4839 Colours 9 4840 Colours 10 4838 Colours 8 4836 Colours 6</p>
<p data-bbox="86 1554 110 1585">9</p>	<p>(Top) 4831 Colours 1 4834 Colours 4 (Bottom Left) 4836 Colours 6 4838 Colours 8 4836 Colours 6 (Bottom Right) 4836 Colours 6 4837 Colours 7 4839 Colours 9 4835 Colours 5</p>

colours 1 4831

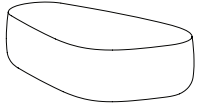

Non-connecting module
Freestanding only
Fully upholstered
Saddle stitch detail

Fabric railroaded
Leather has seamed top

Striped or plaid fabrics and certain patterns with distinct direction are not suitable for application. Solids, textures and leathers are recommended.

When using a combination of fabrics or leathers, specify the application by designating the appropriate letter, shown below, on the purchase order. Yardage shown must be used.

See terms and conditions for contrasting upholstery upcharges.

- A) One fabric or leather for top panel
yardage: 2.0 yds. leather: 35.0 sq. ft.
- B) One fabric or leather for body
yardage: 2.75 yds. leather: 45. sq. ft.

SCS Indoor Advantage™ Gold and LEVEL® 2 certified. See terms and conditions for additional environmental information.

Seat Height	Max. Dim.	W	D	H	Fabric	Leather	Weight	Cubes/Qty
16½"	56⅝"	33½"	59¼"	16½"	3.75 yds.	70.0'	75 lbs.	80.66'/1
419 mm	1445 mm	851 mm	1505 mm	419 mm	3.4 m	6.5 sqm	34.0 kg	2.3 cu.

COM	COL	1	2	3	4	5	6	7	8	9	10	11
2248	2323	2598	2657	2690	2757	2815	2840	2882	2940	2990	3048	3382

colours 13 4843

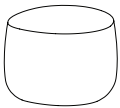

Non-connecting module
Freestanding only
Fully upholstered
Saddle stitch detail

Fabric railroaded
Leather has seamed top

Striped or plaid fabrics and certain patterns with distinct direction are not suitable for application. Solids, textures and leathers are recommended.

When using a combination of fabrics or leathers, specify the application by designating the appropriate letter, shown below, on the purchase order. Yardage shown must be used.

See terms and conditions for contrasting upholstery upcharges.

- A) One fabric or leather for top panel
yardage: 1.0 yds. leather: 14.0 sq. ft.
- B) One fabric or leather for body
yardage: 1.75 yds. leather: 20.0 sq. ft.

SCS Indoor Advantage™ Gold and LEVEL® 2 certified. See terms and conditions for additional environmental information.

Seat Height	Max. Dim.	W	D	H	Fabric	Leather	Weight	Cubes/Qty
17½"	22⅝"	22⅝"	22½"	17½"	2.25 yds.	25.0'	23 lbs.	11.45'/1
445 mm	575 mm	575 mm	572 mm	445 mm	2.1 m	2.3 sqm	10.4 kg	.32 cu.

COM	COL	1	2	3	4	5	6	7	8	9	10	11
1075	1120	1285	1320	1340	1380	1415	1430	1455	1490	1520	1555	1755

colours 2 4832

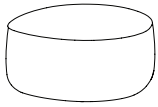

Non-connecting module
Freestanding only
Fully upholstered
Saddle stitch detail

Fabric railroaded
Leather has seamed top

Striped or plaid fabrics and certain patterns with distinct direction are not suitable for application. Solids, textures and leathers are recommended.

When using a combination of fabrics or leathers, specify the application by designating the appropriate letter, shown below, on the purchase order. Yardage shown must be used.

See terms and conditions for contrasting upholstery upcharges.

- A) One fabric or leather for top panel
yardage: 1.75 yds. leather: 30.00 sq. ft.
- B) One fabric or leather for body
yardage: 2.1 yds. leather: 40.0 sq. ft.

SCS Indoor Advantage™ Gold and LEVEL® 2 certified. See terms and conditions for additional environmental information.

Seat Height	Max. Dim.	W	D	H	Fabric	Leather	Weight	Cubes/Qty
16½"	31¼"	32⅝"	31⅝"	16½"	3.6 yds.	65.0'	40 lbs.	22.88'/1
419 mm	794 mm	835 mm	803 mm	419 mm	3.1 m	6.0 sqm	18.1 kg	.65 cu.

COM	COL	1	2	3	4	5	6	7	8	9	10	11
1904	1976	2240	2296	2328	2392	2448	2472	2512	2568	2616	2672	2992

colours 3 4833

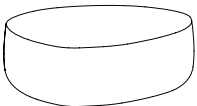

Non-connecting module
Freestanding only
Fully upholstered
Saddle stitch detail

Fabric railroaded
Leather has seamed top

Striped or plaid fabrics and certain patterns with distinct direction are not suitable for application. Solids, textures and leathers are recommended.

When using a combination of fabrics or leathers, specify the application by designating the appropriate letter, shown below, on the purchase order. Yardage shown must be used.

See terms and conditions for contrasting upholstery upcharges.

- A) One fabric or leather for top panel
yardage: 1.55 yds. leather: 30.0 sq. ft.
- B) One fabric or leather for body
yardage: 2.1 yds. leather: 34.0 sq. ft.

SCS Indoor Advantage™ Gold and LEVEL® 2 certified. See terms and conditions for additional environmental information.

Seat Height	Max. Dim.	W	D	H	Fabric	Leather	Weight	Cubes/Qty
16½"	43¾"	43¾"	38¾"	16½"	3.5 yds.	56.7'	71 lbs.	42.66'/1
419 mm	1102 mm	1111 mm	975 mm	419 mm	3.2 m	5.3 sqm	32.2 kg	1.2 cu.

COM	COL	1	2	3	4	5	6	7	8	9	10	11
2591	2661	2918	2973	3004	3066	3120	3144	3183	3237	3284	3338	3649

colours 4 4834

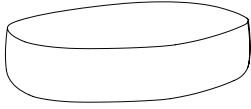

**Non-connecting module
Freestanding only
Fully upholstered
Saddle stitched detail**

Fabric railroaded
Leather has seamed top

Striped or plaid fabrics and certain patterns with distinct direction are not suitable for application. Solids, textures and leathers are recommended.

When using a combination of fabrics or leathers, specify the application by designating the appropriate letter, shown below, on the purchase order. Yardage shown must be used.

See terms and conditions for contrasting upholstery upcharges.

- A) One fabric or leather for top panel
yardage: 2.0 yds. leather: 35.0 sq. ft.
- B) One fabric or leather for body
yardage: 3.75 yds. leather: 60.0 sq. ft.

SCS Indoor Advantage™ Gold and LEVEL® 2 certified. See terms and conditions for additional environmental information.

Seat Height	Max. Dim.	W	D	H	Fabric	Leather	Weight	Cubes/Qty
16½"	60⅞"	61½"	45⅞"	16½"	5.75 yds.	95.0'	85 lbs.	80.66'/1
419 mm	1546 mm	1562 mm	1165 mm	419 mm	5.3 m	8.8 sqm	38.0 kg	2.3 cu.

COM	COL	1	2	3	4	5	6	7	8	9	10	11
3110	3225	3647	3737	3788	3890	3979	4018	4082	4171	4248	4337	4848

colours 5 4835

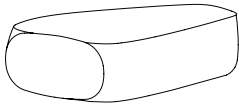

**Connecting module
Fully upholstered
Saddle stitch detail**

Fabric railroaded
Leather has seamed top

Striped or plaid fabrics and certain patterns with distinct direction are not suitable for application. Solids, textures and leathers are recommended.

When using a combination of fabrics or leathers, specify the application by designating the appropriate letter, shown below, on the purchase order. Yardage shown must be used.

See terms and conditions for contrasting upholstery upcharges.

- A) One fabric or leather for top panel
yardage: 1.75 yds. leather: 30.0 sq. ft.
- B) One fabric or leather for body
yardage: 2.6 yds. leather: 40.0 sq. ft.

SCS Indoor Advantage™ Gold and LEVEL® 2 certified. See terms and conditions for additional environmental information.

Seat Height	Max. Dim.	W	D	H	Fabric	Leather	Weight	Cubes/Qty
16½"	52¾"	33"	52¾"	16½"	3.6 yds.	65.0'	51 lbs.	23.14'/1
419 mm	1340 mm	838 mm	1340 mm	419 mm	3.3 m	6.0 sqm	23.2 kg	.66 cu.

COM	COL	1	2	3	4	5	6	7	8	9	10	11
2248	2320	2584	2640	2672	2736	2792	2816	2856	2912	2960	3016	3336

colours 6 4836

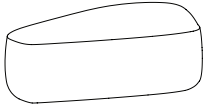

Connecting module
Fully upholstered
Saddle stitch detail

Fabric railroaded
Leather has seamed top

Striped or plaid fabrics and certain patterns with distinct direction are not suitable for application. Solids, textures and leathers are recommended.

When using a combination of fabrics or leathers, specify the application by designating the appropriate letter, shown below, on the purchase order. Yardage shown must be used.

See terms and conditions for contrasting upholstery upcharges.

- A) One fabric or leather for top panel
yardage: 1.75 yds. leather: 30.0 sq. ft.
- B) One fabric or leather for body
yardage: 2.6 yds. leather: 40.0 sq. ft.

SCS Indoor Advantage™ Gold and LEVEL® 2 certified. See terms and conditions for additional environmental information.

Seat Height	Max. Dim.	W	D	H	Fabric	Leather	Weight	Cubes/Qty
16½"	52¾"	33"	52¾"	16½"	3.6 yds.	65.0'	51 lbs.	23.14/1
419 mm	1340 mm	838 mm	1340 mm	419 mm	3.3 m	6.0 sqm	23.2 kg	.66 cu.

COM	COL	1	2	3	4	5	6	7	8	9	10	11
2248	2320	2584	2640	2672	2736	2792	2816	2856	2912	2960	3016	3336

colours 7 4837

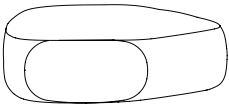

Connecting module
Fully upholstered
Saddle stitch detail

Fabric railroaded
Leather has seamed top

Striped or plaid fabrics and certain patterns with distinct direction are not suitable for application. Solids, textures and leathers are recommended.

When using a combination of fabrics or leathers, specify the application by designating the appropriate letter, shown below, on the purchase order. Yardage shown must be used.

See terms and conditions for contrasting upholstery upcharges.

- A) One fabric or leather for top panel
yardage: 1.75 yds. leather: 30.0 sq. ft.
- B) One fabric or leather for body
yardage: 2.75 yds. leather: 40.0 sq. ft.

SCS Indoor Advantage™ Gold and LEVEL® 2 certified. See terms and conditions for additional environmental information.

Seat Height	Max. Dim.	W	D	H	Fabric	Leather	Weight	Cubes/Qty
16½"	48¾"	48¾"	33¾"	16½"	3.75 yds.	70.0'	51 lbs.	23.14/1
419 mm	1241 mm	1241 mm	857 mm	419 mm	3.4 m	6.5 sqm	23.2 kg	.66 cu.

COM	COL	1	2	3	4	5	6	7	8	9	10	11
2591	2666	2941	3000	3033	3100	3158	3183	3225	3283	3333	3391	3725

colours 8 4838

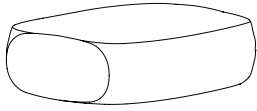

**Connecting module
Fully upholstered
Saddle stitch detail**

Fabric railroaded
Leather has seamed top

Striped or plaid fabrics and certain patterns with distinct direction are not suitable for application. Solids, textures and leathers are recommended.

When using a combination of fabrics or leathers, specify the application by designating the appropriate letter, shown below, on the purchase order. Yardage shown must be used.

See terms and conditions for contrasting upholstery upcharges.

- A) One fabric or leather for top panel
yardage: 1.75 yds. leather: 30.0 sq. ft.
- B) One fabric or leather for body
yardage: 2.65 yds. leather: 30.0 sq. ft.

SCS Indoor Advantage™ Gold and LEVEL® 2 certified. See terms and conditions for additional environmental information.

Seat Height	Max. Dim.	W	D	H	Fabric	Leather	Weight	Cubes/Qty
16½"	54¾"	50¾"	33"	16½"	4.1 yds.	70.0'	51 lbs.	23.14/1
419 mm	1387 mm	1280 mm	838 mm	419 mm	3.7 m	6.5 sqm	23.2 kg	.66 cu.

COM	COL	1	2	3	4	5	6	7	8	9	10	11
2074	2156	2457	2521	2557	2630	2694	2721	2767	2831	2885	2949	3314

colours 9 4839

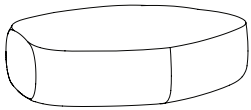

**Connecting module
Fully upholstered
Saddle stitch detail**

Fabric railroaded
Leather has seamed top

Striped or plaid fabrics and certain patterns with distinct direction are not suitable for application. Solids, textures and leathers are recommended.

When using a combination of fabrics or leathers, specify the application by designating the appropriate letter, shown below, on the purchase order. Yardage shown must be used.

See terms and conditions for contrasting upholstery upcharges.

- A) One fabric or leather for top panel
yardage: 2.0 yds. leather: 32.0 sq. ft.
- B) One fabric or leather for body
yardage: 3.6 yds. leather: 65.0 sq. ft.

SCS Indoor Advantage™ Gold and LEVEL® 2 certified. See terms and conditions for additional environmental information.

Seat Height	Max. Dim.	W	D	H	Fabric	Leather	Weight	Cubes/Qty
16½"	59¾"	59¾"	45¾"	16½"	5.25 yds.	90.0'	86 lbs.	80.66/1
419 mm	1508 mm	1508 mm	1162 mm	419 mm	4.8 m	8.4 sqm	39.0 kg	2.3 cu.

COM	COL	1	2	3	4	5	6	7	8	9	10	11
3110	3215	3600	3682	3729	3822	3904	3939	3997	4079	4149	4230	4697

colours 10 4840

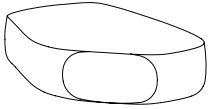

**Connecting module
Fully upholstered
Saddle stitch detail**

Fabric railroaded
Leather has seamed top

Striped or plaid fabrics and certain patterns with distinct direction are not suitable for application. Solids, textures and leathers are recommended.

When using a combination of fabrics or leathers, specify the application by designating the appropriate letter, shown below, on the purchase order. Yardage shown must be used.

See terms and conditions for contrasting upholstery upcharges.

- A) One fabric or leather for top panel
yardage: 2.25 yds. leather: 40.0 sq. ft.
- B) One fabric or leather for body
yardage: 3.0 yds. leather: 50.0 sq. ft.

SCS Indoor Advantage™ Gold and LEVEL® 2 certified. See terms and conditions for additional environmental information.

Seat Height	Max. Dim.	W	D	H	Fabric	Leather	Weight	Cubes/Qty
16½"	66¾"	65¾"	42¾"	16½"	5.5 yds.	85.0'	93 lbs.	80.66'/1
419 mm	1695 mm	1667 mm	1086 mm	419 mm	5.0 m	7.9 sqm	42.2 kg	2.3 cu.

COM	COL	1	2	3	4	5	6	7	8	9	10	11
3454	3564	3968	4053	4102	4200	4286	4322	4383	4469	4542	4628	5117

colours 11 4841

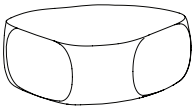

**Connecting module
Fully upholstered
Saddle stitch detail**

Fabric railroaded
Leather has seamed top

Striped or plaid fabrics and certain patterns with distinct direction are not suitable for application. Solids, textures and leathers are recommended.

When using a combination of fabrics or leathers, specify the application by designating the appropriate letter, shown below, on the purchase order. Yardage shown must be used.

See terms and conditions for contrasting upholstery upcharges.

- A) One fabric or leather for top panel
yardage: 1.5 yds. leather: 25.0 sq. ft.
- B) One fabric or leather for body
yardage: 2.0 yds. leather: 32.0 sq. ft.

SCS Indoor Advantage™ Gold and LEVEL® 2 certified. See terms and conditions for additional environmental information.

Seat Height	Max. Dim.	W	D	H	Fabric	Leather	Weight	Cubes/Qty
16½"	42¾"	38½"	37¾"	16½"	3.5 yds.	57.0'	65 lbs.	42.66'/1
419 mm	1089 mm	978 mm	949 mm	419 mm	3.2 m	5.3 sqm	29.5 kg	1.2 cu.

COM	COL	1	2	3	4	5	6	7	8	9	10	11
1904	1974	2231	2286	2317	2379	2433	2457	2496	2550	2597	2651	2962

colours 12 4842

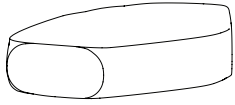

Connecting module
Fully upholstered
Saddle stitch detail

Fabric railroaded
Leather has seamed top

Striped or plaid fabrics and certain patterns with distinct direction are not suitable for application. Solids, textures and leathers are recommended.

When using a combination of fabrics or leathers, specify the application by designating the appropriate letter, shown below, on the purchase order. Yardage shown must be used.

See terms and conditions for contrasting upholstery upcharges.

- A) One fabric or leather for top panel
yardage: 2.4 yds. leather: 40.0 sq. ft.
- B) One fabric or leather for body
yardage: 3.5 yds. leather: 50.0 sq. ft.

SCS Indoor Advantage™ Gold and LEVEL® 2 certified. See terms and conditions for additional environmental information.

Seat Height	Max. Dim.	W	D	H	Fabric	Leather	Weight	Cubes/Qty
16½"	70¾"	70¾"	41¼"	16½"	5.5 yds.	90.0'	90 lbs.	80.66'/1
419 mm	1797 mm	1797 mm	1048 mm	419 mm	5.0 m	8.4 sqm	40.8 kg	2.3 cu.

COM	COL	1	2	3	4	5	6	7	8	9	10	11
3454	3564	3968	4053	4102	4200	4286	4322	4383	4469	4542	4628	5117



friends lounge modular seating collection

Friends Seating System Specification Guide

Standard Features



Friends is an upholstered modular seating system comprised of 35 unique modules which can be used interchangeably to create an unlimited number of configurations. The collection includes freestanding, two-seat, three-seat, corner and connecting modules that are available with and without arms. Arms are available as upholstered, solid oak or solid walnut.

The base is offered in polished aluminum or Bernhardt standard powder coat offerings and has 5/8" diameter non-marring adjustable nylon glides on each leg.

Welt is standard on the seat, back and upholstered arms. All COM/COL fabrics must be preapproved by Bernhardt Design prior to application.

When ordering configurations, please provide the total COM yardage from the same dye lot in a continuous roll(s).

All configurations are connected by pre-installed ganging brackets.

Friends is SCS Indoor Advantage™ Gold certified. See terms and conditions for additional finish and environmental information.

Please visit BernhardtDesign.com for a complete library of 2D, 3D and Revit models. You may also contact your local sales representative or the Bernhardt Design Corporate Office for specification assistance.

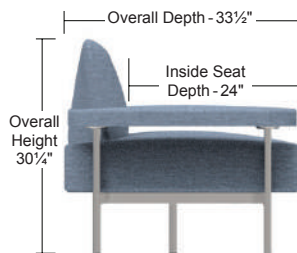

Side View
Showing SKU 5F7XU
Freestanding 3-Seat Sofa

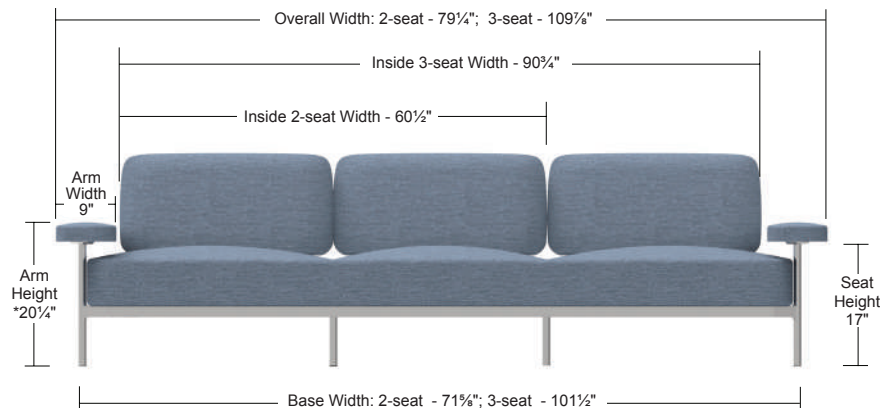

Front View
Showing SKU 5F7XU
Freestanding 3-Seat Sofa
* Arm height shown is for upholstered arm.

Arm Table Options



Oak Table Arm



Walnut Table Arm



Upholstered Table Arm

Solid Wood Selections - Arm Table

When specifying light finishes the natural characteristics of the wood will be visible and color will vary. See terms and conditions for additional finish information.

C Solid Oak
Rift Cut

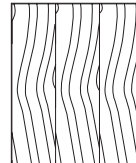

Standard Finish

871 860 870
837 836 861
865 805 866
872 839 845

9 Solid Walnut
Flat Cut

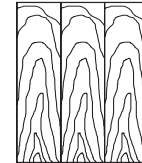

Standard Finish

872 861
860 823
839 866
870 LV8

OAK Select Finishes

M73 M72 M75
M74 M76 M77
M71

Wood Arm Edge Profile

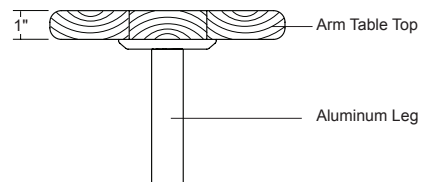

Upholstered Arm Edge Profile

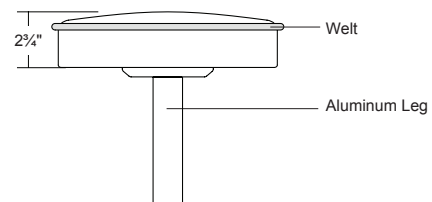

Base Finish Options



Polished Aluminum Base

Base Selections

PA Polished Aluminum

Powder Coat Finishes:

WH Satin White Powder Coat

EC Ecu Powder Coat

LA Latte Powder Coat

AL Matte Aluminum Powder Coat

GR Graphite Powder Coat

BZ Bronze Powder Coat

SG Sage Green Powder Coat

IG Iron Grey Powder Coat

RD Black Red Powder Coat

BK Matte Black Powder Coat

Powder Coat Selections

A two character sku identifies each powder coat finish offered. Individual skus are priced with standard metal finish. Non-standard finishes may incur an additional charge.

Standard Finish



PA Polished Aluminum

Powder Coat Finishes

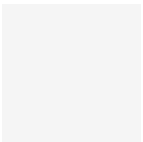

WH Satin White

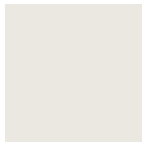

EC Ecu



LA Latte



AL Matte Aluminum



GR Graphite



BZ Bronze



SG Sage



IG Iron Grey



RD Black Red



BK Matte Black

Optional Powder Coat Colors - RAL

- Lead Time - Three weeks additional lead-time after color approval
- Net Up-charge - \$1000 for colors shown in Bernhardt Design RAL Powder Coat Selector
- Minimum Order Quantity - None
- Approval Sample Cost - None
- Combining Products - One up-charge is applicable for multiple products on a single purchase order when they are in the same color

Custom Powder Coat Colors

- Lead Time - Eight weeks additional lead-time after color approval
- Net Upcharge - \$3000 for solid custom colors
- Net Upcharge - To be quoted upon request for metallic custom colors
- Minimum Order Quantity - None
- Approval Sample Cost - None
- Combining Products - One up-charge is applicable for multiple products on a single purchase order when they are in the same color

Note: Metal finish colors may vary between separately ordered skus

Friends Seating System Product Overview

The Friends product overview below shows examples of the different modules that are available within the lounge modular collection. Freestanding and connecting options are available with and without arms. **The freestanding option is not available for connecting modules.**

End connecting modules can be ganged on the straight end of the module. Both end connecting modules and corner seats can be ganged on both ends.

Freestanding Options



Three-seat Freestanding
Available with upholstered or wood arms



Two-seat Freestanding
Available with upholstered or wood arms



Three-seat Freestanding
Armless



Two-seat Freestanding
Armless

Connecting Options



End Connecting Module
(Shown) Three-seat Module, RSF
Available with upholstered or wood arms.
Connects on left end



End Connecting Module
(Shown) Two-seat Module, RSF
Available with upholstered or wood arms.
Connects on left end



End Connecting Module
(Shown) Three-seat Module, RSF Armless
Connects on left end



End Connecting Module
(Shown) Two-seat Module, RSF Armless
Connects on left end



Both Ends Connecting Module
(Shown) Three-seat Armless Module
Connects on both ends



Both Ends Connecting Module
(Shown) Two-seat Armless Module
Connects on both ends



Corner Seat
Connects on both ends

Arm Options



Upholstered Arm



Solid Oak Arm



Solid Walnut Arm



None

Friends Seating System Specification Guide

Sku Description

1

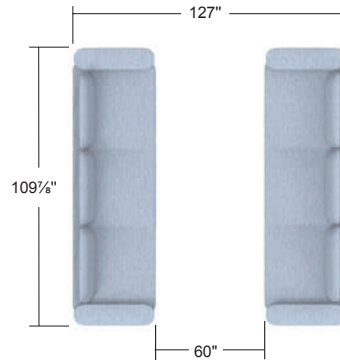

5F7XU Three-seat Freestanding Upholstered Arm

2

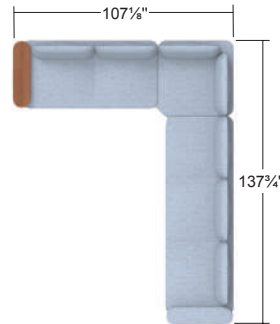

5D5LW Two-seat Module Left Side Facing Solid Walnut Arm

5C5XX Corner Seat

5D7RU Three-seat Module Right Side Facing Upholstered Arm

3

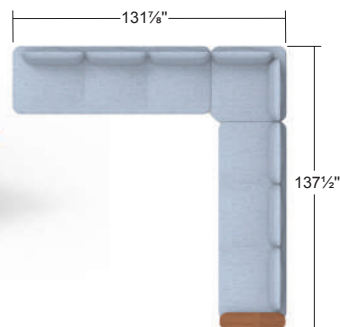

5D7LX Three-seat Armless Module Left Side Facing

5C5XX Corner Seat

5D7RW Three-seat Module Right Side Facing Solid Walnut Arm

Friends Seating System Specification Guide

4

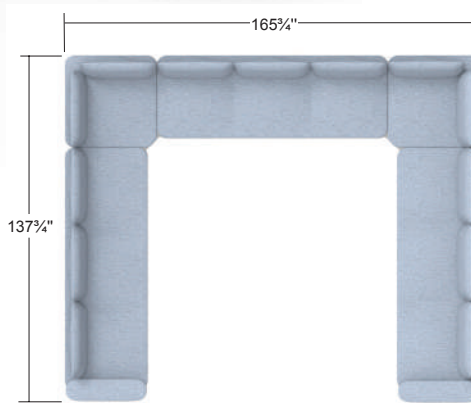

Sku **Description**

- 5D7LU** Three-seat Module
Left Side Facing
Upholstered Arm
- 5C5XX** Corner Seat
- 5B7XX** Three-seat Armless Module
- 5C5XX** Corner Seat
- 5D7RU** Three-seat Module
Right Side Facing
Upholstered Arm

5

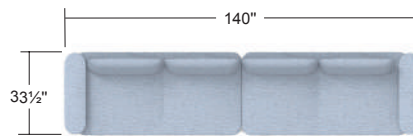

- 5D5LU** Two-seat Module
Left Side Facing
Upholstered Arm
- 5D5RU** Two-seat Module
Right Side Facing
Upholstered Arm

Friends 5F5XU

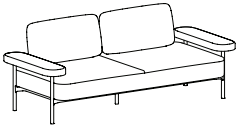

**Two-seat freestanding
Upholstered arms
Polished aluminum or powder coat base
Upholstered seat and back**

Standard with welt
Inside seat width: 62¼", Inside seat depth: 24"

When using a combination of fabrics or leathers, specify the application by designating the appropriate letter, shown below, on the purchase order. Yardage shown must be used.

See terms and conditions for contrasting upholstery upcharges.

- A) One fabric or leather for seat
yardage: 5.0 yds. leather: 81.0 sq. ft.
- B) One fabric or leather for inside back and outside back
yardage: 3.0 yds. leather: 49.0 sq. ft.
- C) One fabric or leather for arm
yardage: 2.5 yds. leather: 40.5 sq. ft.
- D) One fabric or leather for welt
yardage: 1.0 yds. leather: 16.2 sq. ft.

SCS Indoor Advantage™ Gold certified. See terms and conditions for additional environmental information.

Seat Height	Arm Height	W	D	H	Fabric	Leather	Weight	Cubes/Qty
17"	20¼"	74¼"	33½"	30¼"	8.0 yds	130.0'	235 lbs	74.31'/1
432 mm	514 mm	2013 mm	851 mm	768 mm	7.3 m	12.1 sqm	106.6 kg	2.1 cu.

COM	COL	1	2	3	4	5	6	7	8	9	10	11
4100	4260	4847	4972	5043	5185	5309	5363	5452	5576	5683	5807	6518

sku

5F5XU

5 | F | 5 | X | U

base finish

PA polished aluminum standard, OR

specify powder coat, upcharge \$250

- WH satin white
- EC ecru
- LA latte
- AL aluminum
- GR graphite
- BZ bronze
- IG iron grey
- SG sage green
- RD black red
- BK matte black

Friends 5F5XC

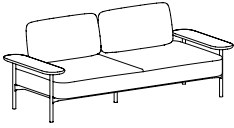

Two-seat freestanding
Solid oak arms
Polished aluminum or powder coat base
Upholstered seat and back

Standard with welt
Inside seat width: 63¼", Inside seat depth: 24"

Table arm available in all oak finishes. When specifying light finish the natural characteristics of the wood will be visible and color will vary.

When using a combination of fabrics or leathers, specify the application by designating the appropriate letter, shown below, on the purchase order. Yardage shown must be used.

See terms and conditions for contrasting upholstery upcharges.

- A) One fabric or leather for seat
yardage: 5.0 yds. leather: 81.0 sq. ft.
- B) One fabric or leather for inside back and outside back
yardage: 3.0 yds. leather: 49.0 sq. ft.
- D) One fabric or leather for welt
yardage: 1.0 yds. leather: 16.2 sq. ft.

SCS Indoor Advantage™ Gold certified. See terms and conditions for additional environmental information.

Seat Height	Arm Height	W	D	H	Fabric	Leather	Weight	Cubes/Qty
17"	18 ½"	73¼"	33½"	30¼"	8.0 yds.	130.0'	235 lbs	74.31'/1
432 mm	470 mm	1861 mm	851 mm	768 mm	7.3 m	12.1 sqm	106.6 kg	2.1 cu.

COM	COL	1	2	3	4	5	6	7	8	9	10	11
4480	4640	5227	5352	5423	5565	5689	5743	5832	5956	6063	6187	6898

sku

5F5XC

5 | F | 5 | X | C |

base finish

PA polished aluminum standard, OR

specify powder coat, upcharge \$250

WH satin white	GR graphite	SG sage green
EC ecru	BZ bronze	RD black red
LA latte	IG iron grey	BK matte black
AL aluminum		

arm finish

see seating finishes - oak

Friends 5F5XW

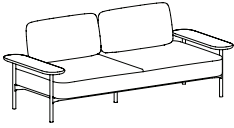

Two-seat freestanding
Solid walnut arms
Polished aluminum or powder coat base
Upholstered seat and back

Standard with welt
Inside seat width: 63¼", Inside seat depth: 24"

Table arm available in all walnut finishes. When specifying light finish the natural characteristics of the wood will be visible and color will vary.

When using a combination of fabrics or leathers, specify the application by designating the appropriate letter, shown below, on the purchase order. Yardage shown must be used.

See terms and conditions for contrasting upholstery upcharges.

- A) One fabric or leather for seat
yardage: 5.0 yds. leather: 81.0 sq. ft.
- B) One fabric or leather for inside back and outside back
yardage: 3.0 yds. leather: 49.0 sq. ft.
- D) One fabric or leather for welt
yardage: 1.0 yds. leather: 16.2 sq. ft.

SCS Indoor Advantage™ Gold certified. See terms and conditions for additional environmental information.

Seat Height	Arm Height	W	D	H	Fabric	Leather	Weight	Cubes/Qty
17"	18 ½"	73¼"	33½"	30¼"	8.0 yds.	130.0'	235 lbs	74.31'/1
432 mm	470 mm	1861 mm	851 mm	768 mm	7.3 m	12.1 sqm	106.6 kg	2.1 cu.

COM	COL	1	2	3	4	5	6	7	8	9	10	11
4480	4640	5227	5352	5423	5565	5689	5743	5832	5956	6063	6187	6898

sku

5F5XW

5 | F | 5 | X | W

base finish

PA polished aluminum standard, OR
specify powder coat, upcharge \$250

WH satin white **GR** graphite **SG** sage green
EC ecru **BZ** bronze **RD** black red
LA latte **IG** iron grey **BK** matte black
AL aluminum

arm finish

see seating
finishes - walnut

Friends 5F5XX

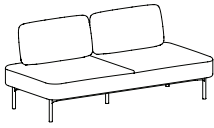

Two-seat freestanding armless
Polished aluminum or powder coat base
Upholstered seat and back

Standard with welt

Inside seat depth: 24"

When using a combination of fabrics or leathers, specify the application by designating the appropriate letter, shown below, on the purchase order. Yardage shown must be used.

See terms and conditions for contrasting upholstery upcharges.

- A) One fabric or leather for seat
yardage: 5.0 yds. leather: 81.0 sq. ft.
- B) One fabric or leather for inside back and outside back
yardage: 3.0 yds. leather: 49.0 sq. ft.
- D) One fabric or leather for welt
yardage: 1.0 yds. leather: 16.2 sq. ft.

SCS Indoor Advantage™ Gold certified. See terms and conditions for additional environmental information.

Seat Height	Arm Height	W	D	H	Fabric	Leather	Weight	Cubes/Qty
17"	-	68¼"	33½"	30¼"	8.0 yds.	130.0'	209 lbs	69.18'/1
432 mm	-	1734 mm	851 mm	768 mm	7.3 m	12.1 sqm	94.1 kg	1.95 cu.

COM	COL	1	2	3	4	5	6	7	8	9	10	11
3730	3890	4477	4602	4673	4815	4939	4993	5082	5206	5313	5437	6148

sku

5F5XX

5 | F | 5 | X | X |

base finish

PA polished aluminum standard, OR

specify powder coat, upcharge \$250

- WH** satin white **GR** graphite **SG** sage green
- EC** ecru **BZ** bronze **RD** black red
- LA** latte **IG** iron grey **BK** matte black
- AL** aluminum

| |

Friends 5F7XU

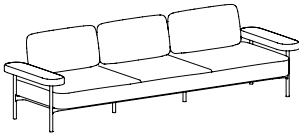

**Three-seat freestanding
Upholstered arms
Polished aluminum or powder coat base
Upholstered seat and back**

Standard with welt

Inside seat width: 90¾", Inside seat depth: 24"

When using a combination of fabrics or leathers, specify the application by designating the appropriate letter, shown below, on the purchase order. Yardage shown must be used.

See terms and conditions for contrasting upholstery upcharges.

- A) One fabric or leather for seat
yardage: 7.0 yds. leather: 113.4 sq. ft.
- B) One fabric or leather for inside back and outside back
yardage: 4.5 yds. leather: 72.9 sq. ft.
- C) One fabric or leather for arm
yardage: 2.5 yds. leather: 40.5 sq. ft.
- D) One fabric or leather for welt
yardage: 1.25 yds. leather: 20.25 sq. ft.

SCS Indoor Advantage™ Gold certified. See terms and conditions for additional environmental information.

Seat Height	Arm Height	W	D	H	Fabric	Leather	Weight	Cubes/Qty
17"	20¼"	109½"	33½"	30¼"	11.25 yds.	182.25'	302 lbs	98.23'/1
432 mm	514 mm	2791 mm	851 mm	768 mm	10.3 m	17.0 sqm	137.0 kg	2.78 cu.

COM	COL	1	2	3	4	5	6	7	8	9	10	11
5275	5500	6325	6500	6600	6800	6975	7050	7175	7350	7500	7675	8675

sku

5F7XU

5	F	7	X	U
---	---	---	---	---

base finish

PA polished aluminum standard, OR

specify powder coat, upcharge \$250

WH satin white	GR graphite	SG sage green
EC ecru	BZ bronze	RD black red
LA latte	IG iron grey	BK matte black
AL aluminum		

Friends 5F7XC

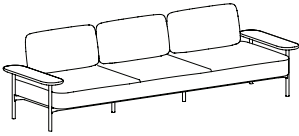

Three-seat freestanding
Solid oak arms
Polished aluminum or powder coat base
Upholstered seat and back

Standard with welt

Inside seat width: 91¾", Inside seat depth: 24"

Table arm available in all oak finishes. When specifying light finish the natural characteristics of the wood will be visible and color will vary.

When using a combination of fabrics or leathers, specify the application by designating the appropriate letter, shown below, on the purchase order. Yardage shown must be used.

See terms and conditions for contrasting upholstery upcharges.

- A) One fabric or leather for seat
yardage: 7.0 yds. leather: 113.4 sq. ft.
- B) One fabric or leather for inside back and outside back
yardage: 4.5 yds. leather: 72.9 sq. ft.
- D) One fabric or leather for welt
yardage: 1.25 yds. leather: 20.25 sq. ft.

SCS Indoor Advantage™ Gold certified. See terms and conditions for additional environmental information.

Seat Height	Arm Height	W	D	H	Fabric	Leather	Weight	Cubes/Qty
17"	18 ½"	108 ¾"	33 ½"	30 ¼"	11.25 yds.	182.25'	302 lbs	98.23/1
432 mm	470 mm	2765 mm	851 mm	768 mm	10.3 m	17.0 sqm	137.0 kg	2.78 cu.

COM	COL	1	2	3	4	5	6	7	8	9	10	11
5665	5890	6715	6890	6990	7190	7365	7440	7565	7740	7890	8065	9065

sku

5F7XC

5 | F | 7 | X | C |

base finish

PA polished aluminum standard, OR
specify powder coat, upcharge \$250

WH satin white	GR graphite	SG sage green
EC ecru	BZ bronze	RD black red
LA latte	IG iron grey	BK matte black
AL aluminum		

arm finish

see seating finishes - oak

Friends 5F7XW

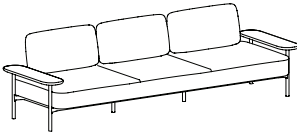

Three-seat freestanding
Solid walnut arms
Polished aluminum or powder coat base
Upholstered seat and back

Standard with welt

Inside seat width: 91¾", Inside seat depth: 24"

Table arm available in all walnut finishes. When specifying light finish the natural characteristics of the wood will be visible and color will vary.

When using a combination of fabrics or leathers, specify the application by designating the appropriate letter, shown below, on the purchase order. Yardage shown must be used.

See terms and conditions for contrasting upholstery upcharges.

- A) One fabric or leather for seat
yardage: 7.0 yds. leather: 113.4 sq. ft.
- B) One fabric or leather for inside back and outside back
yardage: 4.5 yds. leather: 72.9 sq. ft.
- D) One fabric or leather for welt
yardage: 1.25 yds. leather: 20.25 sq. ft.

SCS Indoor Advantage™ Gold certified. See terms and conditions for additional environmental information.

Seat Height	Arm Height	W	D	H	Fabric	Leather	Weight	Cubes/Qty
17"	18 ½"	108 ¾"	33 ½"	30 ¼"	11.25 yds.	182.25'	302 lbs	98.23/1
432 mm	470 mm	2765 mm	851 mm	768 mm	10.3 m	17.0 sqm	137.0 kg	2.78 cu.

COM	COL	1	2	3	4	5	6	7	8	9	10	11
5665	5890	6715	6890	6990	7190	7365	7440	7565	7740	7890	8065	9065

sku

5F7XW

5 | F | 7 | X | W

base finish

PA polished aluminum standard, OR
specify powder coat, upcharge \$250

WH satin white	GR graphite	SG sage green
EC ecru	BZ bronze	RD black red
LA latte	IG iron grey	BK matte black
AL aluminum		

arm finish

see seating finishes - walnut

Friends 5F7XX

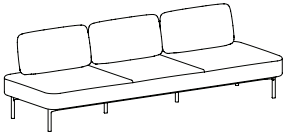

Three-seat freestanding armless
Polished aluminum or powder coat base
Upholstered seat and back

Standard with welt

Inside seat depth: 24"

When using a combination of fabrics or leathers, specify the application by designating the appropriate letter, shown below, on the purchase order. Yardage shown must be used.

See terms and conditions for contrasting upholstery upcharges.

- A) One fabric or leather for seat
yardage: 7.0 yds. leather: 113.4 sq. ft.
- B) One fabric or leather for inside back and outside back
yardage: 4.5 yds. leather: 72.9 sq. ft.
- D) One fabric or leather for welt
yardage: 1.25 yds. leather: 20.25 sq. ft.

SCS Indoor Advantage™ Gold certified. See terms and conditions for additional environmental information.

Seat Height	Arm Height	W	D	H	Fabric	Leather	Weight	Cubes/Qty
17"	-	98¾"	33½"	30¼"	11.25 yds.	182.25'	287 lbs	93.11'/1
432 mm	-	2511 mm	851 mm	768 mm	10.3 m	17.0 sqm	130.2 kg	2.63 cu.

COM	COL	1	2	3	4	5	6	7	8	9	10	11
4915	5140	5965	6140	6240	6440	6615	6690	6815	6990	7140	7315	8315

sku

5F7XX

5 | F | 7 | X | X |

base finish

PA polished aluminum standard, OR

specify powder coat, upcharge \$250

- WH satin white GR graphite SG sage green
- EC ecru BZ bronze RD black red
- LA latte IG iron grey BK matte black
- AL aluminum

| |

Friends 5D5LU and 5D5RU

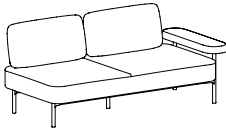
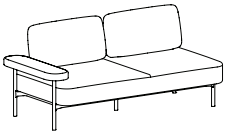

Two-seat module
Upholstered arm
Polished aluminum or powder coat base
Upholstered seat and back

5D5LU Left side facing
5D5RU Right side facing

Standard with welt
All necessary ganging brackets are included and pre-installed
Freestanding option not available

Inside seat width: 61½", Inside seat depth: 24"

When using a combination of fabrics or leathers, specify the application by designating the appropriate letter, shown below, on the purchase order. Yardage shown must be used.

See terms and conditions for contrasting upholstery upcharges.

- A) One fabric or leather for seat
yardage: 5.0 yds. leather: 81.0 sq. ft.
- B) One fabric or leather for inside back and outside back
yardage: 3.0 yds. leather: 49.0 sq. ft.
- C) One fabric or leather for arm
yardage: 2.5 yds. leather: 40.5 sq. ft.
- D) One fabric or leather for welt
yardage: 1.0 yds. leather: 16.2 sq. ft.

SCS Indoor Advantage™ Gold certified. See terms and conditions for additional environmental information.

Seat Height	Arm Height	W	D	H	Fabric	Leather	Weight	Cubes/Qty
17"	20¼"	70"	33½"	30¼"	8.0 yds.	130'	203 lbs	66.63'/1
432 mm	514 mm	1778 mm	851 mm	768 mm	7.3 m	12.1 sqm	92.1 kg	1.88 cu.

COM	COL	1	2	3	4	5	6	7	8	9	10	11
3910	4070	4657	4782	4853	4995	5119	5173	5262	5386	5493	5617	6328

sku
5D5LU left side facing
5D5RU right side facing

base finish
PA polished aluminum standard, OR
specify powder coat, upcharge \$250
WH satin white **GR** graphite **SG** sage green
EC ecru **BZ** bronze **RD** black red
LA latte **IG** iron grey **BK** matte black
AL aluminum

Friends 5D5LC and 5D5RC

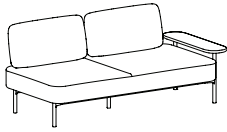
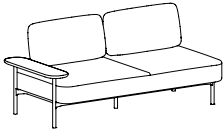

Two-seat module
Solid oak arm
Polished aluminum or powder coat base
Upholstered seat and back

5D5LC Left side facing
5D5RC Right side facing

Standard with welt
All necessary ganging brackets are included and pre-installed
Freestanding option not available

Inside seat width: 62", Inside seat depth: 24"

Table arm available in all oak finishes. When specifying light finish the natural characteristics of the wood will be visible and color will vary.

When using a combination of fabrics or leathers, specify the application by designating the appropriate letter, shown below, on the purchase order. Yardage shown must be used.

See terms and conditions for contrasting upholstery upcharges.

- A) One fabric or leather for seat
yardage: 5.0 yds. leather: 81.0 sq. ft.
- B) One fabric or leather for inside back and outside back
yardage: 3.0 yds. leather: 49.0 sq. ft.
- D) One fabric or leather for welt
yardage: 1.0 yds. leather: 16.2 sq. ft.

SCS Indoor Advantage™ Gold certified. See terms and conditions for additional environmental information.

Seat Height	Arm Height	W	D	H	Fabric	Leather	Weight	Cubes/Qty
17"	18 1/2"	69 3/4"	33 1/2"	30 1/4"	8.0 yds.	130.0'	203 lbs	66.63'/1
432 mm	470 mm	1772 mm	851 mm	768 mm	7.3 m	12.1 sqm	92.1 kg	1.88 cu.

COM	COL	1	2	3	4	5	6	7	8	9	10	11
4110	4270	4857	4982	5053	5195	5319	5373	5462	5586	5693	5817	6528

sku

5D5LC left side facing
5D5RC right side facing

--	--	--	--	--

base finish

PA polished aluminum standard, OR
specify powder coat, upcharge \$250
WH satin white **GR** graphite **SG** sage green
EC ecru **BZ** bronze **RD** black red
LA latte **IG** iron grey **BK** matte black
AL aluminum

--	--	--	--

arm finish

see seating
finishes - oak

--	--	--	--

Friends 5D5LW and 5D5RW

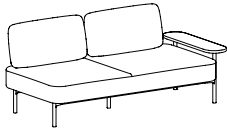
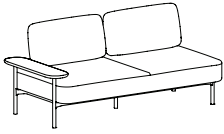

Two-seat module
Solid walnut arm
Polished aluminum or powder coat base
Upholstered seat and back

5D5LW Left side facing
5D5RW Right side facing

Standard with welt
All necessary ganging brackets are included and pre-installed
Freestanding option not available

Inside seat width: 62", Inside seat depth: 24"

Table arm available in all walnut finishes. When specifying light finish the natural characteristics of the wood will be visible and color will vary.

When using a combination of fabrics or leathers, specify the application by designating the appropriate letter, shown below, on the purchase order. Yardage shown must be used.

See terms and conditions for contrasting upholstery upcharges.

- A) One fabric or leather for seat
yardage: 5.0 yds. leather: 81.0 sq. ft.
- B) One fabric or leather for inside back and outside back
yardage: 3.0 yds. leather: 49.0 sq. ft.
- D) One fabric or leather for welt
yardage: 1.0 yds. leather: 16.2 sq. ft.

SCS Indoor Advantage™ Gold certified. See terms and conditions for additional environmental information.

Seat Height	Arm Height	W	D	H	Fabric	Leather	Weight	Cubes/Qty
17"	18 1/2"	69 3/4"	33 1/2"	30 3/4"	8.0 yds.	130.0'	203 lbs	66.63'/1
432 mm	470 mm	1772 mm	851 mm	768 mm	7.3 m	12.1 sqm	92.1 kg	1.88 cu.

COM	COL	1	2	3	4	5	6	7	8	9	10	11
4110	4270	4857	4982	5053	5195	5319	5373	5462	5586	5693	5817	6528

sku

5D5LW left side facing
5D5RW right side facing

--	--	--	--	--

base finish

PA polished aluminum standard, OR
specify powder coat, upcharge \$250
WH satin white **GR** graphite **SG** sage green
EC ecru **BZ** bronze **RD** black red
LA latte **IG** iron grey **BK** matte black
AL aluminum

--	--

arm finish

see seating
finishes - walnut

--	--	--

Friends 5D5LX and 5D5RX

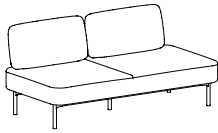
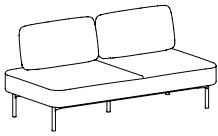

Two-seat armless module
Polished aluminum or powder coat base
Upholstered seat and back

5D5LX Left side facing
5D5RX Right side facing

Standard with welt
All necessary ganging brackets are included and pre-installed
Gangs on straight end of the module
Freestanding option not available

Inside seat depth: 24"

When using a combination of fabrics or leathers, specify the application by designating the appropriate letter, shown below, on the purchase order. Yardage shown must be used.

See terms and conditions for contrasting upholstery upcharges.

- A) One fabric or leather for seat
yardage: 5.0 yds. leather: 81.0 sq. ft.
- B) One fabric or leather for inside back and outside back
yardage: 3.0 yds. leather: 49.0 sq. ft.
- D) One fabric or leather for welt
yardage: 1.0 yds. leather: 16.2 sq. ft.

SCS Indoor Advantage™ Gold certified. See terms and conditions for additional environmental information.

Seat Height	Arm Height	W	D	H	Fabric	Leather	Weight	Cubes/Qty
17"	-	64½"	33½"	30¼"	8.0 yds.	130.0'	188 lbs	64.92'/1
432 mm	-	1629 mm	851 mm	768 mm	7.3 m	12.1 sqm	85.3 kg	1.83 cu.

COM	COL	1	2	3	4	5	6	7	8	9	10	11
3730	3890	4477	4602	4673	4815	4939	4993	5082	5206	5313	5437	6148

sku

5D5LX left side facing
5D5RX right side facing

--	--	--	--	--

base finish

PA polished aluminum standard, OR
specify powder coat, upcharge \$250
WH satin white **GR** graphite **SG** sage green
EC ecru **BZ** bronze **RD** black red
LA latte **IG** iron grey **BK** matte black
AL aluminum

--	--

Friends 5B5XX

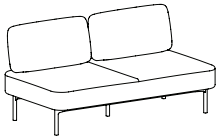

**Two-seat armless module
Polished aluminum or powder coat base
Upholstered seat and back**

Standard with welt
All necessary ganging brackets are included and pre-installed
Gangs on both ends of the module
Freestanding option not available

Inside seat depth: 24"

When using a combination of fabrics or leathers, specify the application by designating the appropriate letter, shown below, on the purchase order. Yardage shown must be used.

See terms and conditions for contrasting upholstery upcharges.

- A) One fabric or leather for seat
yardage: 5.0 yds. leather: 81.0 sq. ft.
- B) One fabric or leather for inside back and outside back
yardage: 3.0 yds. leather: 49.0 sq. ft
- D) One fabric or leather for welt
yardage: 1.0 yds. leather: 16.2 sq. ft.

SCS Indoor Advantage™ Gold certified. See terms and conditions for additional environmental information.

Seat Height	Arm Height	W	D	H	Fabric	Leather	Weight	Cubes/Qty
17"	-	60½"	33½"	30¼"	8.0 yds.	130.0'	173 lbs	62.35'/1
432 mm	-	1540 mm	851 mm	768 mm	7.3 m	12.1 sqm	78.5 kg	1.76 cu.

COM	COL	1	2	3	4	5	6	7	8	9	10	11
3730	3890	4477	4602	4673	4815	4939	4993	5082	5206	5313	5437	6148

sku

5B5XX

5 | B | 5 | X | X |

base finish

PA polished aluminum standard, OR

specify powder coat, upcharge \$250

WH satin white **GR** graphite **SG** sage green
EC ecru **BZ** bronze **RD** black red
LA latte **IG** iron grey **BK** matte black
AL aluminum

Friends 5D7LU and 5D7RU

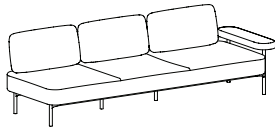
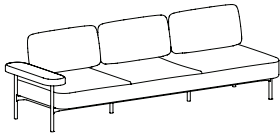

Three-seat module
Upholstered arm
Polished aluminum or powder coat base
Upholstered seat and back

5D7LU Left side facing
5D7RU Right side facing

Standard with welt
All necessary ganging brackets are included and pre-installed
Gangs on straight end of the module
Freestanding option not available

Inside seat width: 90", Inside seat depth: 24"

When using a combination of fabrics or leathers, specify the application by designating the appropriate letter, shown below, on the purchase order. Yardage shown must be used.

See terms and conditions for contrasting upholstery upcharges.

- A) One fabric or leather for seat
yardage: 7.0 yds. leather: 113.4 sq. ft.
- B) One fabric or leather for inside back and outside back
yardage: 4.5 yds. leather: 72.9 sq. ft.
- C) One fabric or leather for arm
yardage: 2.5 yds. leather: 40.5 sq. ft.
- D) One fabric or leather for welt
yardage: 1.25 yds. leather: 20.25 sq. ft.

SCS Indoor Advantage™ Gold certified. See terms and conditions for additional environmental information.

Seat Height	Arm Height	W	D	H	Fabric	Leather	Weight	Cubes/Qty
17"	20¼"	100½"	33½"	30¼"	11.25 yds.	182.25'	272 lbs	93.11'/1
432 mm	514 mm	2550 mm	851 mm	768 mm	10.3 m	17.0 sqm	123.4 kg	2.63 cu.

COM	COL	1	2	3	4	5	6	7	8	9	10	11
5095	5320	6145	6320	6420	6620	6795	6870	6995	7170	7320	7495	8495

sku

5D7LU left side facing
5D7RU right side facing

--	--	--	--	--

base finish

PA polished aluminum standard, OR

specify powder coat, upcharge \$250

WH satin white	GR graphite	SG sage green
EC ecru	BZ bronze	RD black red
LA latte	IG iron grey	BK matte black
AL aluminum		

--	--

Friends 5D7LC and 5D7RC

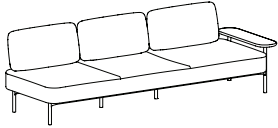
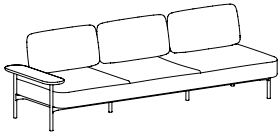

Three-seat module
Solid oak arm
Polished aluminum or powder coat base
Upholstered seat and back

5D7LC Left side facing
5D7RC Right side facing

Standard with welt
 All necessary ganging brackets are included and pre-installed
 Gangs on straight end of the module
 Freestanding option not available

Inside seat width: 90½", Inside seat depth: 24"

Table arm available in all oak finishes. When specifying light finish the natural characteristics of the wood will be visible and color will vary.

When using a combination of fabrics or leathers, specify the application by designating the appropriate letter, shown below, on the purchase order. Yardage shown must be used.

See terms and conditions for contrasting upholstery upcharges.

- A) One fabric or leather for seat
 yardage: 7.0 yds. leather: 113.4 sq. ft.
- B) One fabric or leather for inside back and outside back
 yardage: 4.5 yds. leather: 72.9 sq. ft
- D) One fabric or leather for welt
 yardage: 1.25 yds. leather: 20.25 sq. ft.

SCS Indoor Advantage™ Gold certified. See terms and conditions for additional environmental information.

Seat Height	Arm Height	W	D	H	Fabric	Leather	Weight	Cubes/Qty
17"	18½"	100⅞"	33½"	30¼"	11.25 yds.	182.25'	272 lbs	93.11'/1
432 mm	470 mm	2543 mm	851 mm	768 mm	10.3 m	17.0 sqm	123.4 kg	2.63 cu.

COM	COL	1	2	3	4	5	6	7	8	9	10	11
5300	5525	6350	6525	6625	6825	7000	7075	7200	7375	7525	7700	8700

sku
5D7LC left side facing
5D7RC right side facing

base finish
PA polished aluminum standard, OR
 specify powder coat, upcharge \$250
WH satin white **GR** graphite **SG** sage green
EC ecru **BZ** bronze **RD** black red
LA latte **IG** iron grey **BK** matte black
AL aluminum

arm finish
 see seating
 finishes - oak

Friends 5D7LW and 5D7RW

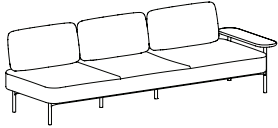
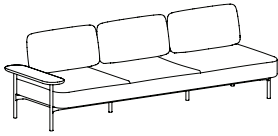

Three-seat module
Solid walnut arm
Polished aluminum or powder coat base
Upholstered seat and back

5D7LW Left side facing
5D7RW Right side facing

Standard with welt
 All necessary ganging brackets are included and pre-installed
 Gangs on straight end of the module
 Freestanding option not available

Inside seat width: 90½", Inside seat depth: 24"

Table arm available in all walnut finishes. When specifying light finish the natural characteristics of the wood will be visible and color will vary.

When using a combination of fabrics or leathers, specify the application by designating the appropriate letter, shown below, on the purchase order. Yardage shown must be used.

See terms and conditions for contrasting upholstery upcharges.

- A) One fabric or leather for seat
 yardage: 7.0 yds. leather: 113.4 sq. ft.
- B) One fabric or leather for inside back and outside back
 yardage: 4.5 yds. leather: 72.9 sq. ft.
- D) One fabric or leather for welt
 yardage: 1.25 yds. leather: 20.25 sq. ft.

SCS Indoor Advantage™ Gold certified. See terms and conditions for additional environmental information.

Seat Height	Arm Height	W	D	H	Fabric	Leather	Weight	Cubes/Qty
17"	18½"	100⅞"	33½"	30¼"	11.25 yds.	182.25'	272 lbs	93.11'/1
432 mm	470 mm	2543 mm	851 mm	768 mm	10.3 m	17.0 sqm	123.4 kg	2.63 cu.

COM	COL	1	2	3	4	5	6	7	8	9	10	11
5300	5525	6350	6525	6625	6825	7000	7075	7200	7375	7525	7700	8700

sku

5D7LW left side facing
5D7RW right side facing

--	--	--	--	--

base finish

PA polished aluminum standard, OR
 specify powder coat, upcharge \$250

WH satin white	GR graphite	SG sage green
EC ecru	BZ bronze	RD black red
LA latte	IG iron grey	BK matte black
AL aluminum		

--	--	--	--

arm finish

see seating finishes - walnut

--	--	--	--

Friends 5D7LX and 5D7RX

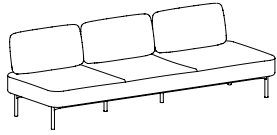
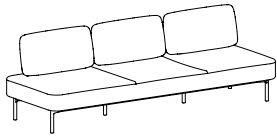

Three-seat armless module
Polished aluminum or powder coat base
Upholstered seat and back

5D7LX Left side facing
5D7RX Right side facing

Standard with welt
All necessary ganging brackets are included and pre-installed
Gangs on straight end of the module
Freestanding option not available

Inside seat depth: 24"

When using a combination of fabrics or leathers, specify the application by designating the appropriate letter, shown below, on the purchase order. Yardage shown must be used.

See terms and conditions for contrasting upholstery upcharges.

- A) One fabric or leather for seat
yardage: 7.0 yds. leather: 113.4 sq. ft.
- B) One fabric or leather for inside back and outside back
yardage: 4.5 yds. leather: 72.9 sq. ft.
- D) One fabric or leather for welt
yardage: 1.25 yds. leather: 20.25 sq. ft.

SCS Indoor Advantage™ Gold certified. See terms and conditions for additional environmental information.

Seat Height	Arm Height	W	D	H	Fabric	Leather	Weight	Cubes/Qty
17"	-	94½"	33½"	30¼"	11.25 yds.	182.25'	262 lbs	90.54'/1
432 mm	-	2400 mm	851 mm	768 mm	10.3 m	17.0 sqm	118.8 kg	2.56 cu.

COM	COL	1	2	3	4	5	6	7	8	9	10	11
4915	5140	5965	6140	6240	6440	6615	6690	6815	6990	7140	7315	8315

sku

5D7LX left side facing
5D7RX right side facing

--	--	--	--	--

base finish

PA polished aluminum standard, OR
specify powder coat, upcharge \$250
WH satin white **GR** graphite **SG** sage green
EC ecru **BZ** bronze **RD** black red
LA latte **IG** iron grey **BK** matte black
AL aluminum

--	--

Friends 5B7XX

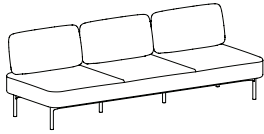

**Three-seat armless module
Polished aluminum or powder coat base
Upholstered seat and back**

Standard with welt
All necessary ganging brackets are included and pre-installed
Gangs on both ends of the module
Freestanding option not available

Inside seat depth: 24"

When using a combination of fabrics or leathers, specify the application by designating the appropriate letter, shown below, on the purchase order. Yardage shown must be used.

See terms and conditions for contrasting upholstery upcharges.

- A) One fabric or leather for seat
yardage: 7.0 yds. leather: 113.4 sq. ft.
- B) One fabric or leather for inside back and outside back
yardage: 4.5 yds. leather: 72.9 sq. ft.
- D) One fabric or leather for welt
yardage: 1.25 yds. leather: 20.25 sq. ft.

SCS Indoor Advantage™ Gold certified. See terms and conditions for additional environmental information.

Seat Height	Arm Height	W	D	H	Fabric	Leather	Weight	Cubes/Qty
17"	-	91"	33½"	30¼"	11.25 yds.	182.25'	242 lbs	87.98'/1
432 mm	-	2311 mm	851 mm	768 mm	10.3 m	17.0 sqm	109.8 kg	2.49 cu.

COM	COL	1	2	3	4	5	6	7	8	9	10	11
4915	5140	5965	6140	6240	6440	6615	6690	6815	6990	7140	7315	8315

sku

5B7XX

5 | B | 7 | X | X |

base finish

PA polished aluminum standard, OR

specify powder coat, upcharge \$250

WH satin white	GR graphite	SG sage green
EC ecru	BZ bronze	RD black red
LA latte	IG iron grey	BK matte black
AL aluminum		

Friends 5C5XX

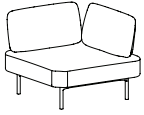

**Corner seat
Polished aluminum or powder coat base
Upholstered seat and back**

Standard with welt
All necessary ganging brackets are included and pre-installed
Gangs on both ends of the module
Freestanding option not available

Inside seat depth: 24"

When using a combination of fabrics or leathers, specify the application by designating the appropriate letter, shown below, on the purchase order. Yardage shown must be used.

See terms and conditions for contrasting upholstery upcharges.

- A) One fabric or leather for seat
yardage: 3.0 yds. leather: 49.0 sq. ft.
- B) One fabric or leather for inside back and outside back
yardage: 3.0 yds. leather: 49.0 sq. ft.
- D) One fabric or leather for welt
yardage: 1.0 yds. leather: 16.2 sq. ft.

SCS Indoor Advantage™ Gold certified. See terms and conditions for additional environmental information.

Seat Height	Arm Height	W	D	H	Fabric	Leather	Weight	Cubes/Qty
17"	-	37½"	37½"	30¼"	5.25 yds.	85.0'	135 lbs	35.02'/1
432 mm	-	950 mm	851 mm	768 mm	4.8 m	7.9 sqm	61.2 kg	.99 cu.

COM	COL	1	2	3	4	5	6	7	8	9	10	11
2975	3080	3465	3547	3594	3687	3769	3804	3862	3944	4014	4095	4562

sku

5C5XX

5 | C | 5 | X | X |

base finish

PA polished aluminum standard, OR

specify powder coat, upcharge \$250

WH satin white	GR graphite	SG sage green
EC ecru	BZ bronze	RD black red
LA latte	IG iron grey	BK matte black
AL aluminum		



gaia lounge modular seating collection

gaia 2215

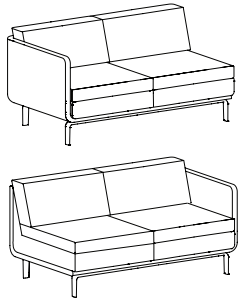

Two-seat
Polished aluminum base with levelers
Upholstered

2215 High arm left facing
2225 High arm right facing

Inside seat depth: 23¾"

When using a combination of fabrics or leathers, specify the application by designating the appropriate letter, shown below, on the purchase order. Yardage shown must be used.

See terms and conditions for contrasting upholstery upcharges.

- A) One fabric or leather for seat cushion, back cushion and front panel
yardage: 8.0 yds. leather: 144.0 sq. ft.
- B) One fabric or leather for shell
yardage: 5.6 yds. leather: 90.0 sq. ft.

SCS Indoor Advantage™ Gold and LEVEL® 2 certified. See terms and conditions for additional environmental information.

Seat Height	Arm Height	W	D	H	Fabric	Leather	Weight	Cubes/Qty
17½"	25¾"	57¾"	33"	29½"	12.8 yds.	252.0'	135 lbs.	68.33'/1
445 mm	654 mm	1457 mm	838 mm	749 mm	11.7 m	23.4 sqm	61.2 kg	1.93 cu.

COM	COL	1	2	3	4	5	6	7	8	9	10	11
6006	6262	7201	7400	7514	7742	7941	8026	8168	8367	8538	8737	9875

gaia 2315

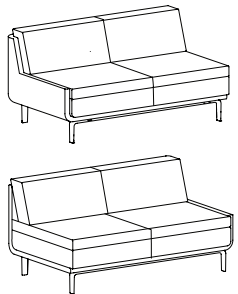

Two-seat
Polished aluminum base with levelers
Upholstered

2315 Low arm left facing
2325 Low arm right facing

Inside seat depth: 23¾"

When using a combination of fabrics or leathers, specify the application by designating the appropriate letter, shown below, on the purchase order. Yardage shown must be used.

See terms and conditions for contrasting upholstery upcharges.

- A) One fabric or leather for seat cushion, back cushion and front panel
yardage: 8.0 yds. leather: 144.0 sq. ft.
- B) One fabric or leather for shell
yardage: 5.6 yds. leather: 90.0 sq. ft.

SCS Indoor Advantage™ Gold and LEVEL® 2 certified. See terms and conditions for additional environmental information.

Seat Height	Arm Height	W	D	H	Fabric	Leather	Weight	Cubes/Qty
17½"	17½"	57¾"	33"	29½"	12.8 yds.	252.0'	135 lbs.	68.33'/1
445 mm	445 mm	1457 mm	838 mm	749 mm	11.7 m	23.4 sqm	61.2 kg	1.93 cu.

COM	COL	1	2	3	4	5	6	7	8	9	10	11
6006	6262	7201	7400	7514	7742	7941	8026	8168	8367	8538	8737	9875

gaia 2217

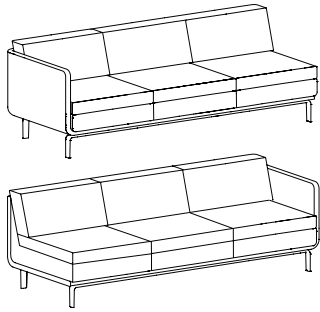

**Three-seat
Polished aluminum base with levelers
Upholstered**

**2217 High arm left facing
2227 High arm right facing**

Inside seat depth: 23¾"

When using a combination of fabrics or leathers, specify the application by designating the appropriate letter, shown below, on the purchase order. Yardage shown must be used.

See terms and conditions for contrasting upholstery upcharges.

- A) One fabric or leather for seat cushion, back cushion and front panel
yardage: 11.5 yds. leather: 210.0 sq. ft.
- B) One fabric or leather for shell
yardage: 7.1 yds. leather: 114.0 sq. ft.

SCS Indoor Advantage™ Gold and LEVEL® 2 certified. See terms and conditions for additional environmental information.

Seat Height	Arm Height	W	D	H	Fabric	Leather	Weight	Cubes/Qty
17½"	25¾"	85¾"	33"	29½"	16.6 yds.	318.0'	150 lbs.	101.65'/1
445 mm	654 mm	2169 mm	838 mm	749 mm	15.2 m	29.5 sqm	67.0 kg	2.88 cu.

COM	COL	1	2	3	4	5	6	7	8	9	10	11
8075	8407	9625	9883	10031	10326	10584	10695	10879	11137	11359	11617	13092

gaia 2317

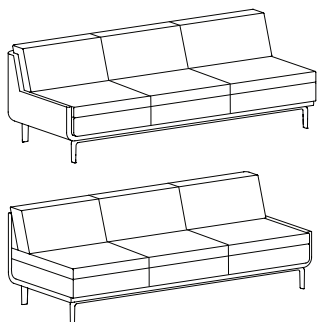

**Three-seat
Polished aluminum base with levelers
Upholstered**

**2317 Low arm left facing
2327 Low arm right facing**

Inside seat depth: 23¾"

When using a combination of fabrics or leathers, specify the application by designating the appropriate letter, shown below, on the purchase order. Yardage shown must be used.

See terms and conditions for contrasting upholstery upcharges.

- A) One fabric or leather for seat cushion, back cushion and front panel
yardage: 11.5 yds. leather: 210.0 sq. ft.
- B) One fabric or leather for shell
yardage: 7.1 yds. leather: 114.0 sq. ft.

SCS Indoor Advantage™ Gold and LEVEL® 2 certified. See terms and conditions for additional environmental information.

Seat Height	Arm Height	W	D	H	Fabric	Leather	Weight	Cubes/Qty
17½"	17½"	85¾"	33"	29½"	16.6 yds.	318.0'	150 lbs.	101.65'/1
445 mm	445 mm	2169 mm	838 mm	749 mm	15.2 m	29.5 sqm	67.0 kg	2.88 cu.

COM	COL	1	2	3	4	5	6	7	8	9	10	11
8075	8407	9625	9883	10031	10326	10584	10695	10879	11137	11359	11617	13092

gaia 2250

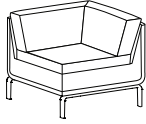

Corner
Polished aluminum base with levelers
Upholstered
Connecting bracket

Inside seat depth: 23¾"

When using a combination of fabrics or leathers, specify the application by designating the appropriate letter, shown below, on the purchase order. Yardage shown must be used.

See terms and conditions for contrasting upholstery upcharges.

- A) One fabric or leather for seat cushion, back cushion and front
yardage: 5.75 yds. leather: 108.0 sq. ft.
- B) One fabric or leather for shell
yardage: 3.0 yds. leather: 48.0 sq. ft.

SCS Indoor Advantage™ Gold and LEVEL® 2 certified. See terms and conditions for additional environmental information.

Seat Height	Arm Height	W	D	H	Fabric	Leather	Weight	Cubes/Qty
17½"	-	33¾"	33"	29½"	7.5 yds.	144.0'	75 lbs.	36.09/1
445 mm	-	857 mm	838 mm	749 mm	6.9 m	13.4 sqm	34.0 kg	1.04 cu.

COM	COL	1	2	3	4	5	6	7	8	9	10	11
4146	4296	4846	4963	5030	5163	5280	5330	5413	5530	5630	5746	6413

Harmony Specification Guide

Harmony is an extensive seating platform which allows you to design your own product. You can easily personalize pieces to create different looks within a space.

Customization is made easy by following a simple menu of options including: style, scale, cushion type, cushion stitching options, fabric application and leg design. The collection of chairs, sofas, benches and modular units are available in two distinctive styles - Classic and Luxe, and two scales - Grande and Standard. Two cushion types are offered, along with five unique stitching details and 24 leg choices. A standalone compact chair is also offered in the classic style.

All necessary ganging brackets are included and pre-installed. When ordering multi-item configurations, provide the total COM yardage from the same dye lot in a continuous roll(s).

Harmony's 11,176 options present endless design possibilities.

The next pages provide an overview of Harmony as well as a guide for ordering. Use these steps below to create your custom design.

1. Select your style: Classic or Luxe
2. Select your scale: Grande or Standard
3. Select the product
4. Select cushion type: Radius or Square
5. Select cushion stitching option
6. Select fabric or leather application
7. Specify leg shape and material. Choose either metal leg/metal finish code or wood leg/wood species. When specifying wood leg make sure to also specify the wood finish code.

Please visit Bernhardtdesign.com for wood finishes, 2D, 3D and Revit models. You may also contact your local sales representative or the Bernhardt Design corporate office for specification assistance. SCS Indoor Advantage™ Gold and LEVEL® 2 certified. See terms and conditions for additional finish and environmental information.

Introduction

Style

Classic



Luxe



Scale

Grande



36¹/₄"w" x 34"d x 29³/₄"h

Standard



34¹/₄"w" x 31¹/₄"d x 29³/₄"h

Compact



31¹/₄"w" x 30¹/₄"d x 29³/₄"h

Cushion Type

Radius - 1



Square - 2



Stitching Options

Standard - A



Standard with Welt - B



Tufted - C



Tufted with Welt - D



Quilted - E



Fabric Application

One Fabric - A



Two Fabrics - B



Three Fabrics - C



Leg Options

Block Walnut - K9



Block Maple - KE



Conical Walnut - I9



Conical Maple - IE



Incline Walnut - J9



Incline Maple - JE



Bevel Walnut - H9



Bevel Maple - HE



Bevel Polished - CP



Bevel Brushed - CB



Bevel Bronze - CZ



Bevel Black - CK



Square Polished - BP



Square Brushed - BB



Square Bronze - BZ



Square Black - BK



Round Polished - AP



Round Brushed - AB



Round Bronze - AZ



Round Black - AK



Ballet Polished - DP



Ballet Brushed - DB





Ballet Bronze - DZ



Ballet Black - DK

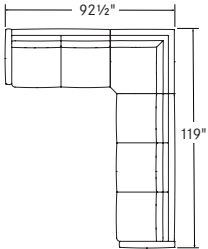

Harmony Seating Sample Configurations - Scale: Standard Style: Classic

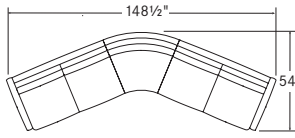
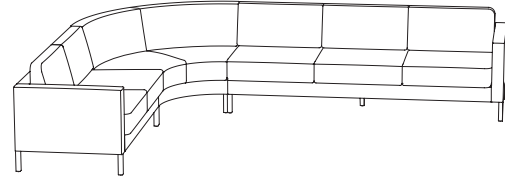
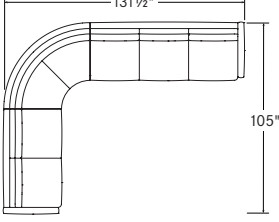
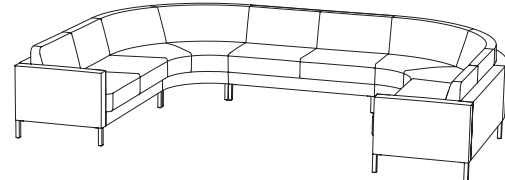
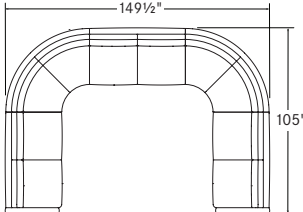
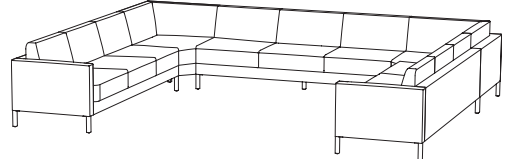
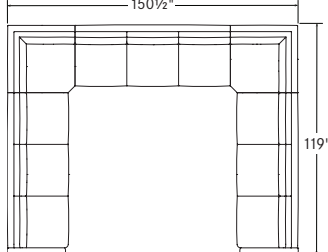
1			<p>K1D Left Side Facing Loveseat K1H Square Corner Chair K1G Right Side Facing Sofa</p>
2			<p>K1D Left Side Facing Loveseat K1I Curved 45° Connector K1E Right Side Facing Loveseat</p>
3			<p>K1D Left Side Facing Loveseat K1J Curved 90° Connector K1G Right Side Facing Sofa</p>
4			<p>K1D Left Side Facing Loveseat K1J Curved 90° Connector K1K Armless Loveseat K1J Curved 90° Connector K1E Right Side Facing Loveseat</p>
5			<p>K1F Left Side Facing Sofa K1H Square Corner Connector K1L Armless Sofa K1H Square Corner Connector K1G Right Side Facing Sofa</p>

Harmony Seating Sample Configurations - Scale: Grande Style: Classic

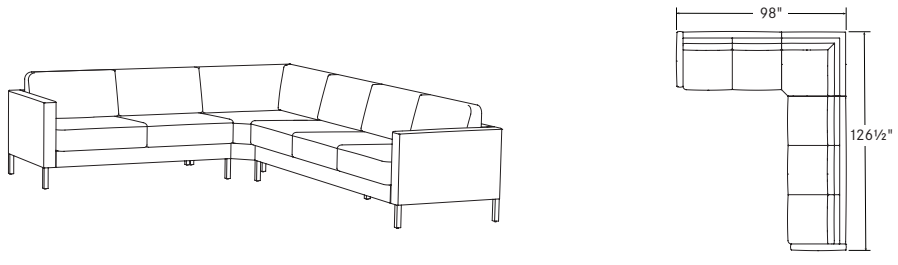
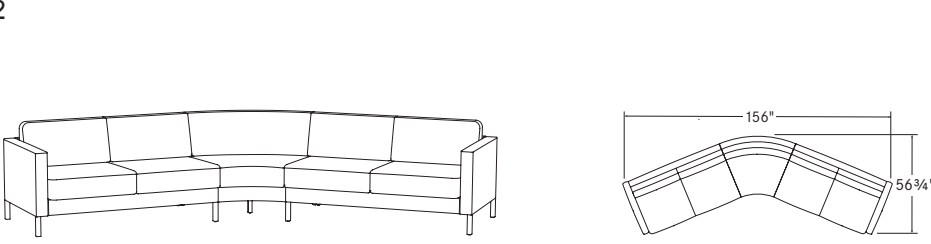
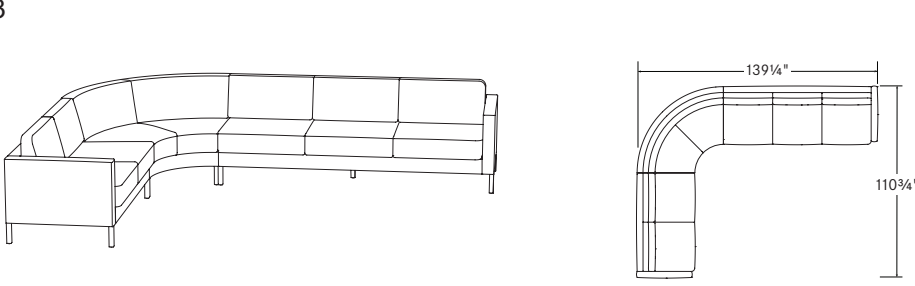
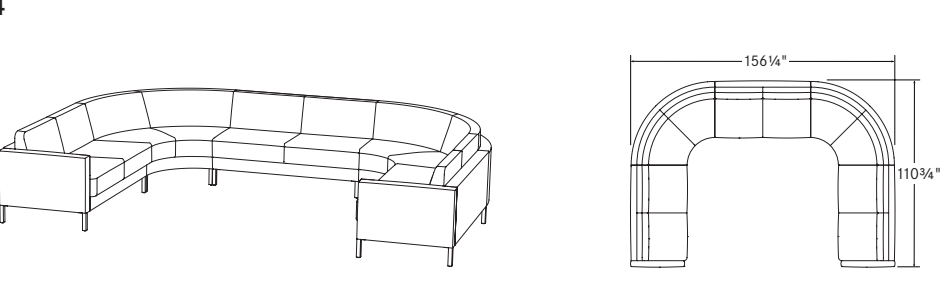
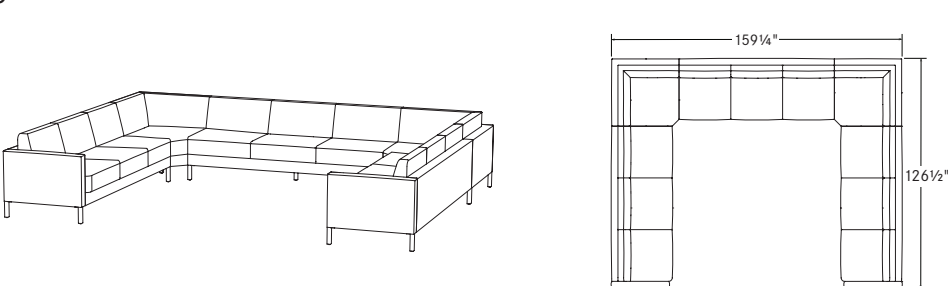
1	Sku Description
	<p>K2D Left Side Facing Loveseat K2H Square Corner Chair K2G Right Side Facing Sofa</p>
	<p>K2D Left Side Facing Loveseat K2I Curved 45° Connector K2E Right Side Facing Loveseat</p>
	<p>K2D Left Side Facing Loveseat K2J Curved 90° Connector K2G Right Side Facing Sofa</p>
	<p>K2D Left Side Facing Loveseat K2J Curved 90° Connector K2K Armless Loveseat K2J Curved 90° Connector K2E Right Side Facing Loveseat</p>
	<p>K2F Left Side Facing Sofa K2H Square Corner Connector K2L Armless Sofa K2H Square Corner Connector K2G Right Side Facing Sofa</p>

Harmony Seating Sample Configurations - Scale: Luxe

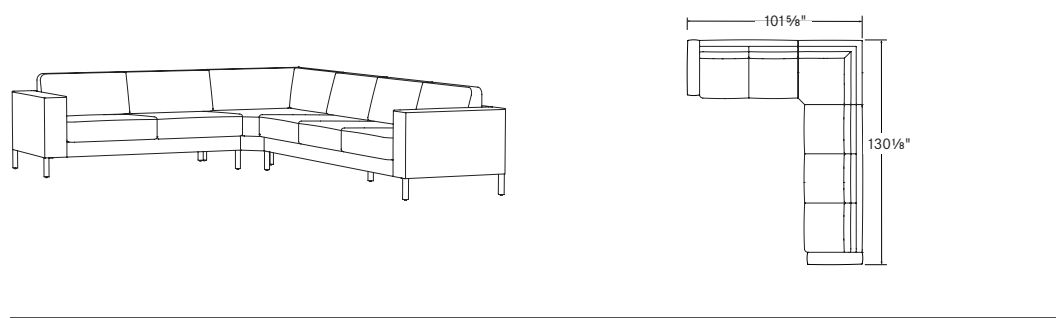
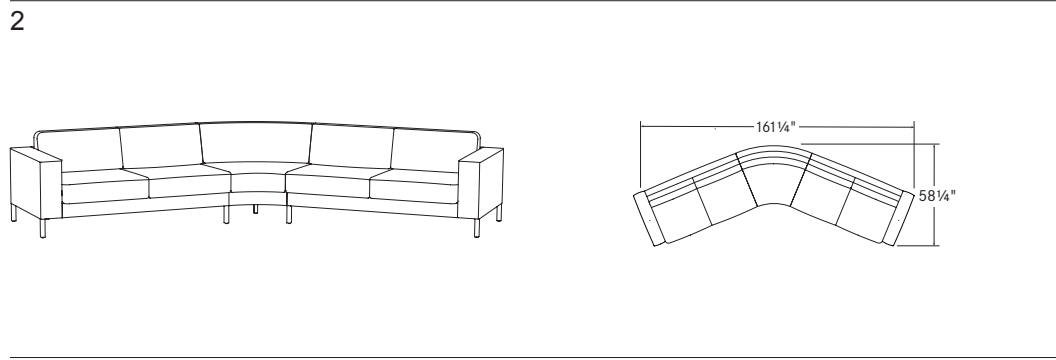
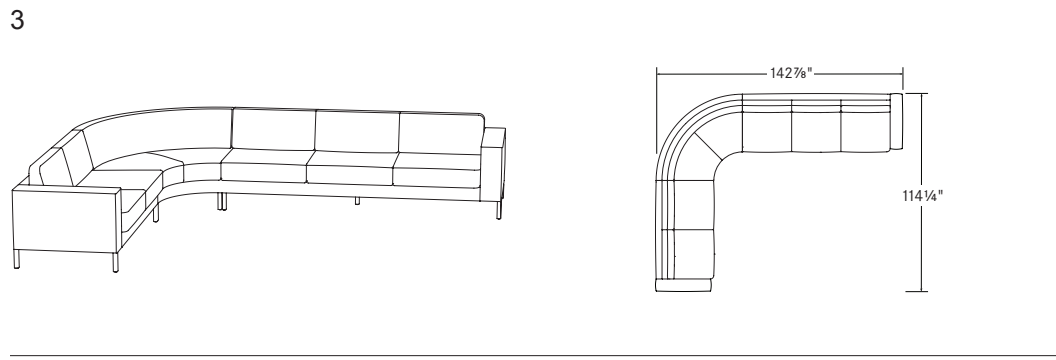
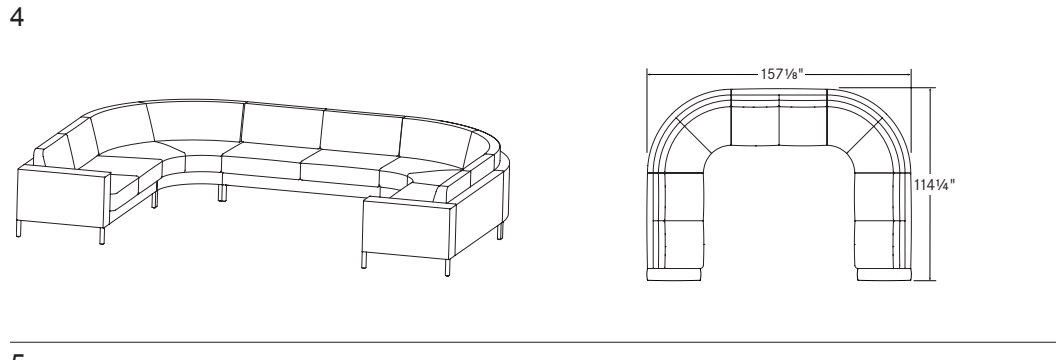
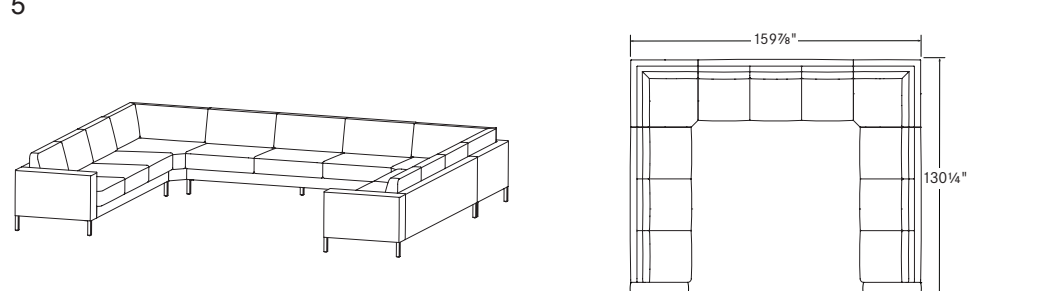
1	Sku Description
	<p>K3D Left Side Facing Loveseat K3H Square Corner Chair K3G Right Side Facing Sofa</p>
	<p>K3D Left Side Facing Loveseat K3I Curved 45° Connector K3E Right Side Facing Loveseat</p>
	<p>K3D Left Side Facing Loveseat K3J Curved 90° Connector K3G Right Side Facing Sofa</p>
	<p>K3D Left Side Facing Loveseat K3J Curved 90° Connector K3K Armless Loveseat K3J Curved 90° Connector K3E Right Side Facing Loveseat</p>
	<p>K3F Left Side Facing Sofa K3H Square Corner Connector K3L Armless Sofa K3H Square Corner Connector K3G Right Side Facing Sofa</p>

classic standard

classic standard K1A

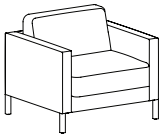

Chair Upholstered

Metal or wood legs. Wood legs available in all maple and walnut finishes. When specifying light finishes the natural characteristics of the wood will be visible and color will vary.

When using a combination of fabrics or leathers, specify the application by designating the appropriate letter, shown below, on the purchase order. Yardage shown must be used.

See terms and conditions for contrasting upholstery and welt upcharges.

- A) One fabric or leather for seat cushion and back cushion
yardage: 3.75 yds. leather: 60.0 sq. ft.
- B) One fabric or leather for body
yardage: 3.75 yds. leather: 60.0 sq. ft.
- C) One fabric or leather for welt and/or buttons
yardage: 1.0 yds. leather: 10.0 sq. ft.

**Cushion upcharge: B & C cushion add \$100. D & E cushion add \$200.

SCS Indoor Advantage™ Gold and LEVEL® 2 certified. See terms and conditions for additional finish and environmental information.

Seat Height	Arm Height	W	D	H	Fabric	Leather	Weight	Cubes/Qty
17½"	24 ½"	34¼"	31¾"	29¾"	7.5 yds.	115.0'	99 lbs.	22.67/1
445 mm	622 mm	870 mm	806 mm	756 mm	6.9 m	10.7sqm	45.0 kg	.64 cu.

COM	COL	1	2	3	4	5	6	7	8	9	10	11
2657	2807	3357	3474	3541	3674	3791	3841	3924	4041	4141	4257	4924

sku	cushion type	cushion stitching options		metal leg	metal finish code	wood leg	wood species	wood finish code
_____	1 radius cushions 2 square cushions	A standard B with welt** C tufted**	D tufted with welt** E quilted** **cushion upcharges	A round B square C bevel D ballet	Z bronze K black P polished B brushed	H bevel I conical J incline K block	E maple 9 walnut	see seating finishes
_____	_____	_____	_____	_____	_____	_____	_____	_____

Choose: metal leg/metal finish code or wood leg/wood species.

classic standard

classic standard K1B

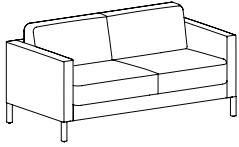

Loveseat Upholstered

Metal or wood legs. Wood legs available in all maple and walnut finishes. When specifying light finishes the natural characteristics of the wood will be visible and color will vary.

When using a combination of fabrics or leathers, specify the application by designating the appropriate letter, shown below, on the purchase order. Yardage shown must be used.

See terms and conditions for contrasting upholstery and welt upcharges.

- A) One fabric or leather for seat cushion and back cushion
yardage: 7.25 yds. leather: 110.0 sq. ft.
- B) One fabric or leather for body
yardage: 7.25 yds. leather: 110.0 sq. ft.
- C) One fabric or leather for welt and/or buttons
yardage: 1.5 yds. leather: 15.0 sq. ft.

**Cushion upcharge: B & C cushion add \$150. D & E cushion add \$300.

SCS Indoor Advantage™ Gold and LEVEL® 2 certified. See terms and conditions for additional finish and environmental information.

Seat Height	Arm Height	W	D	H	Fabric	Leather	Weight	Cubes/Qty
17½"	24 ½"	60¾"	31¾"	29¾"	14.25 yds.	230.0'	129.0 lbs.	42.67/1
445 mm	622 mm	1543 mm	806 mm	756 mm	13.0 m	21.4 sqm	58.6 kg	1.21 cu.

COM	COL	1	2	3	4	5	6	7	8	9	10	11
4128	4413	5458	5680	5807	6060	6282	6377	6535	6757	6947	7168	8435

sku	cushion type	cushion stitching options		metal leg	metal finish code	wood leg	wood species	wood finish code
	1 radius cushions 2 square cushions	A standard B with welt** C tufted**	D tufted with welt** E quilted** **cushion upcharges	A round B square C bevel D ballet	Z bronze K black P polished B brushed	H bevel I conical J incline K block	E maple 9 walnut	see seating finishes

Choose: metal leg/metal finish code or wood leg/wood species.

classic standard

classic standard K1C

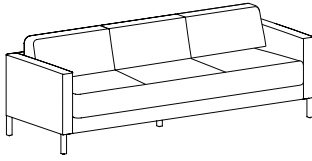

Sofa Upholstered

Metal or wood legs. Wood legs available in all maple and walnut finishes. When specifying light finishes the natural characteristics of the wood will be visible and color will vary.

When using a combination of fabrics or leathers, specify the application by designating the appropriate letter, shown below, on the purchase order. Yardage shown must be used.

See terms and conditions for contrasting upholstery and welt upcharges.

- A) One fabric or leather for seat cushion and back cushion
yardage: 10.75 yds. leather: 160.0 sq. ft.
- B) One fabric or leather for body
yardage: 8.8 yds. leather: 130.0 sq. ft.
- C) One fabric or leather for welt and/or buttons
yardage: 1.75 yds. leather: 20.0 sq. ft.

**Cushion upcharge: B & C cushion add \$200. D & E cushion add \$400.

SCS Indoor Advantage™ Gold and LEVEL® 2 certified. See terms and conditions for additional finish and environmental information.

Seat Height	Arm Height	W	D	H	Fabric	Leather	Weight	Cubes/Qty
17½"	24½"	87¼"	31¾"	29¾"	19.5 yds.	315.0'	171 lbs.	56.67/1
445 mm	622 mm	2216 mm	806 mm	756 mm	17.8 m	29.3 sqm	77.6 kg	1.60 cu.

COM	COL	1	2	3	4	5	6	7	8	9	10	11
5307	5697	7127	7431	7604	7951	8254	8384	8601	8904	9164	9467	11201

sku	cushion type	cushion stitching options		metal leg	metal finish code	wood leg	wood species	wood finish code
<input type="text"/>	1 radius cushions 2 square cushions	A standard B with welt** C tufted**	D tufted with welt** E quilted** **cushion upcharges	A round B square C bevel D ballet	Z bronze K black P polished B brushed	H bevel I conical J incline K block	E maple 9 walnut	see seating finishes
<input type="text"/>	<input type="text"/>	<input type="text"/>	<input type="text"/>	<input type="text"/>	<input type="text"/>	<input type="text"/>	<input type="text"/>	<input type="text"/>

Choose: metal leg/metal finish code or wood leg/wood species.

classic standard

classic standard K1D

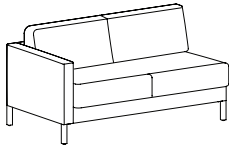

**Left side facing loveseat
Upholstered**

All necessary ganging brackets are included and pre-installed

Not intended for freestanding purposes due to unfinished ends. When being used as freestanding, contact Bernhardt Design for pricing. Radius cushions are not available on freestanding K1D.

Metal or wood legs. Wood legs available in all maple and walnut finishes. When specifying light finishes the natural characteristics of the wood will be visible and color will vary.

When using a combination of fabrics or leathers, specify the application by designating the appropriate letter, shown below, on the purchase order. Yardage shown must be used.

See terms and conditions for contrasting upholstery and welt upcharges.

- A) One fabric or leather for seat cushion and back cushion
yardage: 7.25 yds. leather: 110.0 sq. ft.
- B) One fabric or leather for body
yardage: 5.5 yds. leather: 80.0 sq. ft.
- C) One fabric or leather for welt and/or buttons
yardage: 1.5 yds. leather: 15.0 sq. ft.

**Cushion upcharge: B & C cushion add \$150. D & E cushion add \$300.

SCS Indoor Advantage™ Gold and LEVEL® 2 certified. See terms and conditions for additional finish and environmental information.

Seat Height	Arm Height	W	D	H	Fabric	Leather	Weight	Cubes/Qty
17½"	24½"	57"	31¾"	29¾"	12.75 yds.	206.0'	108 lbs.	40.0/1
445 mm	622 mm	1448 mm	806 mm	756 mm	11.7 m	19.1 sqm	49.1 kg	1.13 cu.

COM	COL	1	2	3	4	5	6	7	8	9	10	11
3686	3941	4876	5075	5188	5415	5613	5698	5840	6038	6208	6406	7540

sku	cushion type	cushion stitching options	metal leg	metal finish code	wood leg	wood species	wood finish code
<input type="text"/>	1 radius cushions 2 square cushions	A standard B with welt** C tufted** D tufted with welt** E quilted** **cushion upcharges	A round B square C bevel D ballet	Z bronze K black P polished B brushed	H bevel I conical J incline K block	E maple 9 walnut	see seating finishes
<input type="text"/>	<input type="text"/>	<input type="text"/>	<input type="text"/>	<input type="text"/>	<input type="text"/>	<input type="text"/>	<input type="text"/>

Choose: metal leg/metal finish code or wood leg/wood species.

classic standard

classic standard K1E

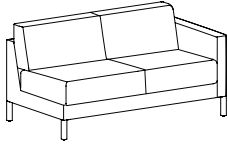

**Right side facing loveseat
Upholstered**

All necessary ganging brackets are included and pre-installed

Not intended for freestanding purposes due to unfinished ends. When being used as freestanding, contact Bernhardt Design for pricing. Radius cushions are not available on freestanding K1E.

Metal or wood legs. Wood legs available in all maple and walnut finishes. When specifying light finishes the natural characteristics of the wood will be visible and color will vary.

When using a combination of fabrics or leathers, specify the application by designating the appropriate letter, shown below, on the purchase order. Yardage shown must be used.

See terms and conditions for contrasting upholstery and welt upcharges.

- A) One fabric or leather for seat cushion and back cushion
yardage: 7.25 yds. leather: 110.0 sq. ft.
- B) One fabric or leather for body
yardage: 5.5 yds. leather: 80.0 sq. ft.
- C) One fabric or leather for welt and/or buttons
yardage: 1.5 yds. leather: 15.0 sq. ft.

**Cushion upcharge: B & C cushion add \$150. D & E cushion add \$300.

SCS Indoor Advantage™ Gold and LEVEL® 2 certified. See terms and conditions for additional finish and environmental information.

Seat Height	Arm Height	W	D	H	Fabric	Leather	Weight	Cubes/Qty
17½"	24½"	57"	31¾"	29¾"	12.75 yds.	206.0'	108 lbs.	40.0/1
445 mm	622 mm	1448 mm	806 mm	756 mm	11.7 m	19.1 sqm	49.1 kg	1.13 cu.

COM	COL	1	2	3	4	5	6	7	8	9	10	11
3686	3941	4876	5075	5188	5415	5613	5698	5840	6038	6208	6406	7540

sku	cushion type	cushion stitching options		metal leg	metal finish code	wood leg	wood species	wood finish code
_____	1 radius cushions 2 square cushions	A standard B with welt** C tufted**	D tufted with welt** E quilted** **cushion upcharges	A round B square C bevel D ballet	Z bronze K black P polished B brushed	H bevel I conical J incline K block	E maple 9 walnut	see seating finishes
_____	_____	_____	_____	_____	_____	_____	_____	_____

Choose: metal leg/metal finish code or wood leg/wood species.

classic standard

classic standard K1K

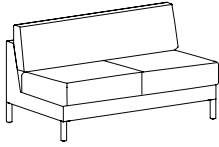

**Armless loveseat
Upholstered**

All necessary ganging brackets are included and pre-installed

Not intended for freestanding purposes due to unfinished ends. When being used as freestanding, contact Bernhardt Design for pricing. Radius cushions are not available on freestanding K1K.

Metal or wood legs. Wood legs available in all maple and walnut finishes. When specifying light finishes the natural characteristics of the wood will be visible and color will vary.

When using a combination of fabrics or leathers, specify the application by designating the appropriate letter, shown below, on the purchase order. Yardage shown must be used.

See terms and conditions for contrasting upholstery and welt upcharges.

- A) One fabric or leather for seat cushion and back cushion
yardage: 7.25 yds. leather: 110.0 sq. ft.
- B) One fabric or leather for body
yardage: 4.25 yds. leather: 70.0 sq. ft.
- C) One fabric or leather for welt and/or buttons
yardage: 1.5 yds. leather: 15.0 sq. ft.

**Cushion upcharge: B & C cushion add \$150. D & E cushion add \$300.

SCS Indoor Advantage™ Gold and LEVEL® 2 certified. See terms and conditions for additional finish and environmental information.

Seat Height	Arm Height	W	D	H	Fabric	Leather	Weight	Cubes/Qty
17½"	-	53½"	31¾"	29¾"	11.2 yds.	182.0'	101 lbs.	35.26'/1
445 mm	-	1359 mm	806 mm	756 mm	10.2 m	16.9 sqm	45.9 kg	1.0 cu.

COM	COL	1	2	3	4	5	6	7	8	9	10	11
3243	3468	4293	4468	4568	4768	4943	5018	5143	5318	5468	5643	6643

sku	cushion type	cushion stitching options	metal leg	metal finish code	wood leg	wood species	wood finish code
<input type="text"/>	1 radius cushions 2 square cushions	A standard B with welt** C tufted** D tufted with welt** E quilted** **cushion upcharges	A round B square C bevel D ballet	Z bronze K black P polished B brushed	H bevel I conical J incline K block	E maple 9 walnut	see seating finishes

Choose: metal leg/metal finish code or wood leg/wood species.

classic standard

classic standard K1F

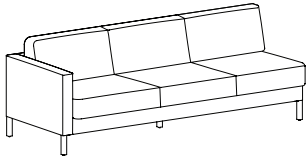

**Left side facing sofa
Upholstered**

All necessary ganging brackets are included and pre-installed

Not intended for freestanding purposes due to unfinished ends. When being used as freestanding, contact Bernhardt Design for pricing. Radius cushions are not available on freestanding K1F.

Metal or wood legs. Wood legs available in all maple and walnut finishes. When specifying light finishes the natural characteristics of the wood will be visible and color will vary.

When using a combination of fabrics or leathers, specify the application by designating the appropriate letter, shown below, on the purchase order. Yardage shown must be used.

See terms and conditions for contrasting upholstery and welt upcharges.

- A) One fabric or leather for seat cushion and back cushion
yardage: 10.75 yds. leather: 160.0 sq. ft.
- B) One fabric or leather for body
yardage: 7.5 yds. leather: 115.0 sq. ft.
- C) One fabric or leather for welt and/or buttons
yardage: 1.75 yds. leather: 20.0 sq. ft.

**Cushion upcharge: B & C cushion add \$200. D & E cushion add \$400.

SCS Indoor Advantage™ Gold and LEVEL® 2 certified. See terms and conditions for additional finish and environmental information.

Seat Height	Arm Height	W	D	H	Fabric	Leather	Weight	Cubes/Qty
17½"	24½"	83½"	31¾"	29¾"	18.25 yds.	296.0'	154 lbs.	54.15'/1
445 mm	622 mm	2121 mm	806 mm	756 mm	16.7 m	27.5 sqm	70.0 kg	1.53 cu.

COM	COL	1	2	3	4	5	6	7	8	9	10	11
4864	5229	6568	6852	7014	7338	7622	7744	7947	8231	8474	8758	10380

sku	cushion type	cushion stitching options		metal leg	metal finish code	wood leg	wood species	wood finish code
_____	1 radius cushions 2 square cushions	A standard B with welt** C tufted**	D tufted with welt** E quilted** **cushion upcharges	A round B square C bevel D ballet	Z bronze K black P polished B brushed	H bevel I conical J incline K block	E maple 9 walnut	see seating finishes
_____	_____	_____	_____	_____	_____	_____	_____	_____

Choose: metal leg/metal finish code or wood leg/wood species.

classic standard

classic standard K1G

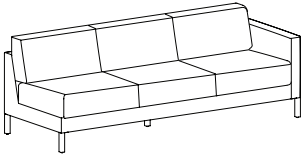

**Right side facing sofa
Upholstered**

All necessary ganging brackets are included and pre-installed

Not intended for freestanding purposes due to unfinished ends. When being used as freestanding, contact Bernhardt Design for pricing. Radius cushions are not available on freestanding K1G.

Metal or wood legs. Wood legs available in all maple and walnut finishes. When specifying light finishes the natural characteristics of the wood will be visible and color will vary.

When using a combination of fabrics or leathers, specify the application by designating the appropriate letter, shown below, on the purchase order. Yardage shown must be used.

See terms and conditions for contrasting upholstery and welt upcharges.

- A) One fabric or leather for seat cushion and back cushion
yardage: 10.75 yds. leather: 160.0 sq. ft.
- B) One fabric or leather for body
yardage: 7.5 yds. leather: 115.0 sq. ft.
- C) One fabric or leather for welt and/or buttons
yardage: 1.75 yds. leather: 20.0 sq. ft.

**Cushion upcharge: B & C cushion add \$200. D & E cushion add \$400.

SCS Indoor Advantage™ Gold and LEVEL® 2 certified. See terms and conditions for additional finish and environmental information.

Seat Height	Arm Height	W	D	H	Fabric	Leather	Weight	Cubes/Qty
17½"	24½"	83½"	31¾"	29¾"	18.25 yds.	296.0'	154 lbs.	54.15'/1
445 mm	622 mm	2121 mm	806 mm	756 mm	16.7 m	27.5 sqm	70.0 kg	1.53 cu.

COM	COL	1	2	3	4	5	6	7	8	9	10	11
4864	5229	6568	6852	7014	7338	7622	7744	7947	8231	8474	8758	10380

sku	cushion type	cushion stitching options	metal leg	metal finish code	wood leg	wood species	wood finish code
<input type="text"/>	1 radius cushions 2 square cushions	A standard B with welt** C tufted** D tufted with welt** E quilted** **cushion upcharges	A round B square C bevel D ballet	Z bronze K black P polished B brushed	H bevel I conical J incline K block	E maple 9 walnut	see seating finishes
<input type="text"/>	<input type="text"/>	<input type="text"/>	<input type="text"/>	<input type="text"/>	<input type="text"/>	<input type="text"/>	<input type="text"/>

Choose: metal leg/metal finish code or wood leg/wood species.

classic standard

classic standard K1L

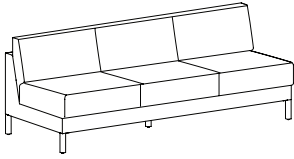

**Armless sofa
Upholstered**

All necessary ganging brackets are included and pre-installed

Not intended for freestanding purposes due to unfinished ends. When being used as freestanding, contact Bernhardt Design for pricing. Radius cushions are not available on freestanding K1L.

Metal or wood legs. Wood legs available in all maple and walnut finishes. When specifying light finishes the natural characteristics of the wood will be visible and color will vary.

When using a combination of fabrics or leathers, specify the application by designating the appropriate letter, shown below, on the purchase order. Yardage shown must be used.

See terms and conditions for contrasting upholstery and welt upcharges.

- A) One fabric or leather for seat cushion and back cushion
yardage: 11.0 yds. leather: 162.0 sq. ft.
- B) One fabric or leather for body
yardage: 6.75 yds. leather: 95.0 sq. ft.
- C) One fabric or leather for welt and/or buttons
yardage: 1.75 yds. leather: 20.0 sq. ft.

**Cushion upcharge: B & C cushion add \$200. D & E cushion add \$400.

SCS Indoor Advantage™ Gold and LEVEL® 2 certified. See terms and conditions for additional finish and environmental information.

Seat Height	Arm Height	W	H	D	Fabric	Leather	Weight	Cubes/Qty
17½"	-	80"	29¾"	31 ¾"	16.5 yds.	267.0'	141 lbs.	51.63'/1
445 mm	-	2032 mm	806 mm	756 mm	15.1 m	24.8 sqm	60.0 kg	1.5 cu.

COM	COL	1	2	3	4	5	6	7	8	9	10	11
4423	4753	5963	6220	6367	6660	6917	7027	7210	7467	7687	7943	9410

sku	cushion type	cushion stitching options		metal leg	metal finish code	wood leg	wood species	wood finish code
<input type="text"/>	1 radius cushions 2 square cushions	A standard B with welt** C tufted**	D tufted with welt** E quilted** **cushion upcharges	A round B square C bevel D ballet	Z bronze K black P polished B brushed	H bevel I conical J incline K block	E maple 9 walnut	see seating finishes
<input type="text"/>	<input type="text"/>	<input type="text"/>	<input type="text"/>	<input type="text"/>	<input type="text"/>	<input type="text"/>	<input type="text"/>	<input type="text"/>

Choose: metal leg/metal finish code or wood leg/wood species.

classic standard

classic standard K1H

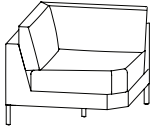

**Square corner chair
Upholstered**

All necessary ganging brackets are included and pre-installed

Not intended for freestanding purposes due to unfinished ends. When being used as freestanding, contact Bernhardt Design for pricing. Radius cushions are not available on freestanding K1H.

Metal or wood legs. Wood legs available in all maple and walnut finishes. When specifying light finishes the natural characteristics of the wood will be visible and color will vary.

When using a combination of fabrics or leathers, specify the application by designating the appropriate letter, shown below, on the purchase order. Yardage shown must be used.

See terms and conditions for contrasting upholstery and welt upcharges..

- A) One fabric or leather for seat cushion and back cushion
yardage: 5.1 yds. leather: 82.0 sq. ft.
- B) One fabric or leather for body
yardage: 3.75 yds. leather: 60.0 sq. ft.
- C) One fabric or leather for welt and/or buttons
yardage: 1.0 yds. leather: 10.0 sq. ft.

**Cushion upcharge: B & C cushion add \$150. D & E cushion add \$300.

CSS Indoor Advantage™ Gold and LEVEL® 2 certified. See terms and conditions for additional finish and environmental information.

Seat Height	Arm Height	W	D	H	Fabric	Leather	Weight	Cubes/Qty
17½"	-	35½"	35½"	29¼"	8.75 yds.	145.0'	89 lbs.	26.74/1
445 mm	-	902 mm	902 mm	756 mm	8.0 m	13.5 sqm	40.5 kg	.76 cu.

COM	COL	1	2	3	4	5	6	7	8	9	10	11
3243	3418	4060	4196	4274	4430	4566	4624	4721	4857	4974	5110	5888

sku	cushion type	cushion stitching options	metal leg	metal finish code	wood leg	wood species	wood finish code
<input type="text"/>	1 radius cushions 2 square cushions	A standard B with welt** C tufted** D tufted with welt** E quilted** **cushion upcharges	A round B square C bevel D ballet	Z bronze K black P polished B brushed	H bevel I conical J incline K block	E maple 9 walnut	see seating finishes

Choose: metal leg/metal finish code or wood leg/wood species.

classic standard

classic standard K11



**Curved 45° connector
Upholstered**

All necessary ganging brackets are included and pre-installed

Not intended for freestanding purposes due to unfinished ends. When being used as freestanding, contact Bernhardt Design for pricing. Radius cushions are not available on freestanding K11.

Metal or wood legs. Wood legs available in all maple and walnut finishes. When specifying light finishes the natural characteristics of the wood will be visible and color will vary.

When using a combination of fabrics or leathers, specify the application by designating the appropriate letter, shown below, on the purchase order. Yardage shown must be used.

See terms and conditions for contrasting upholstery and welt upcharges.

- A) One fabric or leather for seat cushion and back cushion
yardage: 4.25 yds. leather: 70.0 sq. ft.
- B) One fabric or leather for body
yardage: 2.5 yds. leather: 35.0 sq. ft.
- C) One fabric or leather for welt and/or buttons
yardage: 1.0 yds. leather: 10.0 sq. ft.

**Cushion upcharge: B & C cushion add \$150. D & E cushion add \$300.

SCS Indoor Advantage™ Gold and LEVEL® 2 certified. See terms and conditions for additional finish and environmental information.

Seat Height	Arm Height	W	D	H	Fabric	Leather	Weight	Cubes/Qty
17 1/2"	-	43 1/4"	34 1/2"	29 3/8"	6.8 yds.	110.0'	97 lbs.	30.67/1
445 mm	-	1099 mm	877 mm	756 mm	6.2 m	10.3 sqm	44.1 kg	.87 cu.

COM	COL	1	2	3	4	5	6	7	8	9	10	11
2948	3084	3583	3689	3749	3870	3976	4021	4097	4203	4293	4399	5004

sku	cushion type	cushion stitching options		metal leg	metal finish code	wood leg	wood species	wood finish code
_____	1 radius cushions 2 square cushions	A standard B with welt** C tufted**	D tufted with welt** E quilted** **cushion upcharges	A round B square C bevel D ballet	Z bronze K black P polished B brushed	H bevel I conical J incline K block	E maple 9 walnut	see seating finishes
_____	_____	_____	_____	_____	_____	_____	_____	_____

Choose: metal leg/metal finish code or wood leg/wood species.

classic standard

classic standard K1J

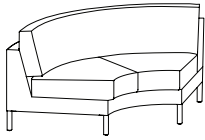

Curved 90° connector Upholstered

All necessary ganging brackets are included and pre-installed

Not intended for freestanding purposes due to unfinished ends. When being used as freestanding, contact Bernhardt Design for pricing. Radius cushions are not available on freestanding K1J.

Metal or wood legs. Wood legs available in all maple and walnut finishes. When specifying light finishes the natural characteristics of the wood will be visible and color will vary.

When using a combination of fabrics or leathers, specify the application by designating the appropriate letter, shown below, on the purchase order. Yardage shown must be used.

See terms and conditions for contrasting upholstery and welt upcharges.

- A) One fabric or leather for seat cushion and back cushion
yardage: 7.25 yds. leather: 110.0 sq. ft.
- B) One fabric or leather for body
yardage: 3.75 yds. leather: 60.0 sq. ft.
- C) One fabric or leather for welt and/or buttons
yardage: 1.0 yds. leather: 10.0 sq. ft.

**Cushion upcharge: B & C cushion add \$150. D & E cushion add \$300.

SCS Indoor Advantage™ Gold and LEVEL® 2 certified. See terms and conditions for additional finish and environmental information.

Seat Height	Arm Height	W	H	D	Fabric	Leather	Weight	Cubes/Qty
17½"	-	68¼"	36 1/2"	29 3/4"	11.0 yds.	178.0'	137 lbs.	53.33'/1
445 mm	-	1734 mm	927 mm	756 mm	10.1 m	16.5 sqm	62.3 kg	1.51 cu.

COM	COL	1	2	3	4	5	6	7	8	9	10	11
3981	4201	5008	5179	5277	5473	5644	5717	5839	6010	6157	6328	7306

sku	cushion type	cushion stitching options	metal leg	metal finish code	wood leg	wood species	wood finish code
<input type="text"/>	1 radius cushions 2 square cushions	A standard B with welt** C tufted** D tufted with welt** E quilted** **cushion upcharges	A round B square C bevel D ballet	Z bronze K black P polished B brushed	H bevel I conical J incline K block	E maple 9 walnut	see seating finishes
<input type="text"/>	<input type="text"/>	<input type="text"/>	<input type="text"/>	<input type="text"/>	<input type="text"/>	<input type="text"/>	<input type="text"/>

Choose: metal leg/metal finish code or wood leg/wood species.

classic grande

classic grande K2A

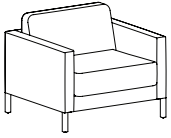

Chair Upholstered

Metal or wood legs. Wood legs available in all maple and walnut finishes. When specifying light finishes the natural characteristics of the wood will be visible and color will vary.

When using a combination of fabrics or leathers, specify the application by designating the appropriate letter, shown below, on the purchase order. Yardage shown must be used.

See terms and conditions for contrasting upholstery and welt upcharges.

- A) One fabric or leather for seat cushion and back cushion
yardage: 4.0 yds. leather: 65.0 sq. ft.
- B) One fabric or leather for body
yardage: 4.0 yds. leather: 65.0 sq. ft.
- C) One fabric or leather for welt and/or buttons on cushions
yardage: 1.0 yds. leather: 10.0 sq. ft.

**Cushion upcharge: B & C cushion add \$100. D & E cushion add \$200.

SCS Indoor Advantage™ Gold and LEVEL® 2 certified. See terms and conditions for additional finish and environmental information.

Seat Height	Arm Height	W	D	H	Fabric	Leather	Weight	Cubes/Qty
17½"	24 ½"	36¼"	34"	29¾"	7.5 yds.	115.0'	107 lbs.	25.33'/1
445 mm	622 mm	921 mm	864 mm	756 mm	6.9 m	10.7 sqm	48.6 kg	.72 cu.

COM	COL	1	2	3	4	5	6	7	8	9	10	11
2802	2952	3502	3619	3686	3819	3936	3986	4069	4186	4286	4402	5069

sku	cushion type	cushion stitching options		metal leg	metal finish code	wood leg	wood species	wood finish code
<input type="text"/>	1 radius cushions 2 square cushions	A standard B with welt** C tufted**	D tufted with welt** E quilted** **cushion upcharges	A round B square C bevel D ballet	Z bronze K black P polished B brushed	H bevel I conical J incline K block	E maple 9 walnut	see seating finishes
<input type="text"/>	<input type="text"/>	<input type="text"/>	<input type="text"/>	<input type="text"/>	<input type="text"/>	<input type="text"/>	<input type="text"/>	<input type="text"/>

Choose: metal leg/metal finish code or wood leg/wood species.

classic grande

classic grande K2B

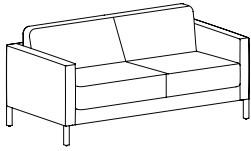

Loveseat Upholstered

Metal or wood legs. Wood legs available in all maple and walnut finishes. When specifying light finishes the natural characteristics of the wood will be visible and color will vary.

When using a combination of fabrics or leathers, specify the application by designating the appropriate letter, shown below, on the purchase order. Yardage shown must be used.

See terms and conditions for contrasting upholstery and welt upcharges.

- A) One fabric or leather for seat cushion and back cushion
yardage: 7.5 yds. leather: 115.0 sq. ft.
- B) One fabric or leather for body
yardage: 7.5 yds. leather: 115.0 sq. ft.
- C) One fabric or leather for welt and/or buttons on cushions
yardage: 1.5 yds. leather: 15.0 sq. ft.

**Cushion upcharge: B & C cushion add \$150. D & E cushion add \$300.

SCS Indoor Advantage™ Gold and LEVEL® 2 certified. See terms and conditions for additional finish and environmental information.

Seat Height	Arm Height	W	D	H	Fabric	Leather	Weight	Cubes/Qty
17½"	24 ½"	64¾"	34"	29¾"	14.5 yds.	235.0'	134 lbs.	45.33'/1
445 mm	622 mm	1645 mm	864 mm	756 mm	13.3 m	21.8 sqm	60.9 kg	1.28 cu.

COM	COL	1	2	3	4	5	6	7	8	9	10	11
4423	4713	5777	6002	6131	6389	6615	6711	6872	7098	7291	7517	8806

sku	cushion type	cushion stitching options		metal leg	metal finish code	wood leg	wood species	wood finish code
<input type="text"/>	1 radius cushions 2 square cushions	A standard B with welt** C tufted**	D tufted with welt** E quilted** **cushion upcharges	A round B square C bevel D ballet	Z bronze K black P polished B brushed	H bevel I conical J incline K block	E maple 9 walnut	see seating finishes
<input type="text"/>	<input type="text"/>	<input type="text"/>	<input type="text"/>	<input type="text"/>	<input type="text"/>	<input type="text"/>	<input type="text"/>	<input type="text"/>

Choose: metal leg/metal finish code or wood leg/wood species.

classic grande

classic grande K2C

Sofa Upholstered

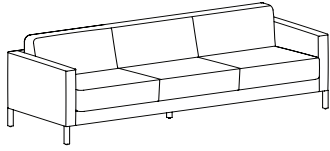

Metal or wood legs. Wood legs available in all maple and walnut finishes. When specifying light finishes the natural characteristics of the wood will be visible and color will vary.

When using a combination of fabrics or leathers, specify the application by designating the appropriate letter, shown below, on the purchase order. Yardage shown must be used.

See terms and conditions for contrasting upholstery and welt upcharges.

- A) One fabric or leather for seat cushion and back cushion
yardage: 11.0 yds. leather: 162.0 sq. ft.
- B) One fabric or leather for body
yardage: 9.25 yds. leather: 135.0 sq. ft.
- C) One fabric or leather for welt and/or buttons on cushions
yardage: 1.75 yds. leather: 20.0 sq. ft.

**Cushion upcharge: B & C cushion add \$200. D & E cushion add \$400.

SCS Indoor Advantage™ Gold and LEVEL® 2 certified. See terms and conditions for additional finish and environmental information.

Seat Height	Arm Height	W	D	H	Fabric	Leather	Weight	Cubes/Qty
17½"	24½"	93¼"	34"	29¾"	19.75 yds.	320.0'	179 lbs.	64.0'/1
445 mm	622 mm	2369 mm	864 mm	756 mm	18.1 m	29.7 sqm	81.4 kg	1.8 cu.

COM	COL	1	2	3	4	5	6	7	8	9	10	11
5601	5996	7445	7752	7928	8279	8586	8718	8937	9244	9508	9815	11570

sku	cushion type	cushion stitching options		metal leg	metal finish code	wood leg	wood species	wood finish code
<input type="text"/>	1 radius cushions 2 square cushions	A standard B with welt** C tufted**	D tufted with welt** E quilted** **cushion upcharges	A round B square C bevel D ballet	Z bronze K black P polished B brushed	H bevel I conical J incline K block	E maple 9 walnut	see seating finishes
<input type="text"/>	<input type="text"/>	<input type="text"/>	<input type="text"/>	<input type="text"/>	<input type="text"/>	<input type="text"/>	<input type="text"/>	<input type="text"/>

Choose: metal leg/metal finish code or wood leg/wood species.

classic grande

classic grande K2D

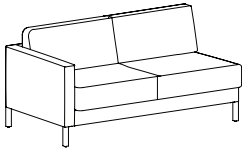

**Left side facing loveseat
Upholstered**

All necessary ganging brackets are included and pre-installed

Not intended for freestanding purposes due to unfinished ends. When being used as freestanding, contact Bernhardt Design for pricing. Radius cushions are not available on freestanding K2D.

Metal or wood legs. Wood legs available in all maple and walnut finishes. When specifying light finishes the natural characteristics of the wood will be visible and color will vary.

When using a combination of fabrics or leathers, specify the application by designating the appropriate letter, shown below, on the purchase order. Yardage shown must be used.

See terms and conditions for contrasting upholstery and welt upcharges.

- A) One fabric or leather for seat cushion and back cushion
yardage: 7.5 yds. leather: 121.0 sq. ft.
- B) One fabric or leather for body
yardage: 5.75 yds. leather: 9 5.0 sq. ft.
- C) One fabric or leather for welt and/or buttons
yardage: 1.5 yds. leather: 15.0 sq. ft.

**Cushion upcharge: B & C cushion add \$150. D & E cushion add \$300.

SCS Indoor Advantage™ Gold and LEVEL® 2 certified. See terms and conditions for additional finish and environmental information.

Seat Height	Arm Height	W	D	H	Fabric	Leather	Weight	Cubes/Qty
17½"	24½"	61"	34"	29¾"	13.0 yds.	210.0'	139 lbs.	42.67/1
445 mm	622 mm	1549 mm	864 mm	756 mm	11.9 m	19.5 sqm	63.2 kg	1.21 cu.

COM	COL	1	2	3	4	5	6	7	8	9	10	11
3981	4241	5195	5397	5513	5744	5946	6033	6177	6379	6553	6755	7910

sku	cushion type	cushion stitching options	metal leg	metal finish code	wood leg	wood species	wood finish code
<input type="text"/>	1 radius cushions 2 square cushions	A standard B with welt** C tufted** D tufted with welt** E quilted** **cushion upcharges	A round B square C bevel D ballet	Z bronze K black P polished B brushed	H bevel I conical J incline K block	E maple 9 walnut	see seating finishes
<input type="text"/>	<input type="text"/>	<input type="text"/>	<input type="text"/>	<input type="text"/>	<input type="text"/>	<input type="text"/>	<input type="text"/>

Choose: metal leg/metal finish code or wood leg/wood species.

classic grande

classic grande K2E

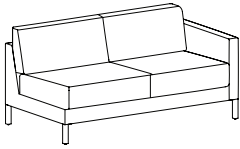

**Right side facing loveseat
Upholstered**

All necessary ganging brackets are included and pre-installed

Not intended for freestanding purposes due to unfinished ends. When being used as freestanding, contact Bernhardt Design for pricing. Radius cushions are not available on freestanding K2E.

Metal or wood legs. Wood legs available in all maple and walnut finishes. When specifying light finishes the natural characteristics of the wood will be visible and color will vary.

When using a combination of fabrics or leathers, specify the application by designating the appropriate letter, shown below, on the purchase order. Yardage shown must be used.

See terms and conditions for contrasting upholstery and welt upcharges.

- A) One fabric or leather for seat cushion and back cushion
yardage: 7.5 yds. leather: 115.0 sq. ft.
- B) One fabric or leather for body
yardage: 5.75 yds. leather: 81.0 sq. ft.
- C) One fabric or leather for welt and/or buttons
yardage: 1.5 yds. leather: 15.0 sq. ft.

**Cushion upcharge: B & C cushion add \$150. D & E cushion add \$300.

SCS Indoor Advantage™ Gold and LEVEL® 2 certified. See terms and conditions for additional finish and environmental information.

Seat Height	Arm Height	W	D	H	Fabric	Leather	Weight	Cubes/Qty
17½"	24½"	61"	34"	29¾"	13.0 yds.	210.0'	139 lbs.	42.67/1
445 mm	622 mm	1549 mm	864 mm	756 mm	11.9 m	19.5 sqm	63.2 kg	1.21 cu.

COM	COL	1	2	3	4	5	6	7	8	9	10	11
3981	4241	5195	5397	5513	5744	5946	6033	6177	6379	6553	6755	7910

sku	cushion type	cushion stitching options	metal leg	metal finish code	wood leg	wood species	wood finish code
<input type="text"/>	1 radius cushions 2 square cushions	A standard B with welt** C tufted** D tufted with welt** E quilted** **cushion upcharges	A round B square C bevel D ballet	Z bronze K black P polished B brushed	H bevel I conical J incline K block	E maple 9 walnut	see seating finishes

Choose: metal leg/metal finish code or wood leg/wood species.

classic grande

classic grande K2K

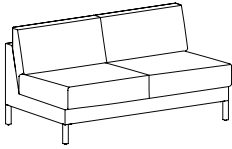

**Armless loveseat
Upholstered**

All necessary ganging brackets are included and pre-installed

Not intended for freestanding purposes due to unfinished ends. When being used as freestanding, contact Bernhardt Design for pricing. Radius cushions are not available on freestanding K2K.

Metal or wood legs. Wood legs available in all maple and walnut finishes. When specifying light finishes the natural characteristics of the wood will be visible and color will vary.

When using a combination of fabrics or leathers, specify the application by designating the appropriate letter, shown below, on the purchase order. Yardage shown must be used.

See terms and conditions for contrasting upholstery and welt upcharges.

- A) One fabric or leather for seat cushion and back cushion
yardage: 7.5 yds. leather: 115.0 sq. ft.
- B) One fabric or leather for body
yardage: 6.0 yds. leather: 90.0 sq. ft.
- C) One fabric or leather for welt and/or buttons
yardage: 1.5 yds. leather: 15.0 sq. ft.

**Cushion upcharge: B & C cushion add \$150. D & E cushion add \$300.

SCS Indoor Advantage™ Gold and LEVEL® 2 certified. See terms and conditions for additional finish and environmental information.

Seat Height	Arm Height	W	D	H	Fabric	Leather	Weight	Cubes/Qty
17½"	-	57½"	34"	29¾"	11.5 yds.	186.0'	128 lbs.	40.0/1
445 mm	-	1461 mm	864 mm	756 mm	10.5 m	17.3 sqm	58.2 kg	1.13 cu.

COM	COL	1	2	3	4	5	6	7	8	9	10	11
3539	3769	4613	4792	4894	5098	5277	5354	5482	5661	5814	5993	7015

sku	cushion type	cushion stitching options	metal leg	metal finish code	wood leg	wood species	wood finish code
<input type="text"/>	1 radius cushions 2 square cushions	A standard B with welt** C tufted** D tufted with welt** E quilted** **cushion upcharges	A round B square C bevel D ballet	Z bronze K black P polished B brushed	H bevel I conical J incline K block	E maple 9 walnut	see seating finishes
<input type="text"/>	<input type="text"/>	<input type="text"/>	<input type="text"/>	<input type="text"/>	<input type="text"/>	<input type="text"/>	<input type="text"/>

Choose: metal leg/metal finish code or wood leg/wood species.

classic grande

classic grande K2F

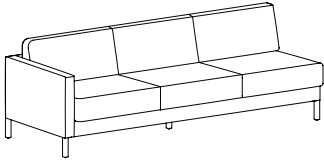

**Left side facing sofa
Upholstered**

All necessary ganging brackets are included and pre-installed

Not intended for freestanding purposes due to unfinished ends. When being used as freestanding, contact Bernhardt Design for pricing. Radius cushions are not available on freestanding K2F.

Metal or wood legs. Wood legs available in all maple and walnut finishes. When specifying light finishes the natural characteristics of the wood will be visible and color will vary.

When using a combination of fabrics or leathers, specify the application by designating the appropriate letter, shown below, on the purchase order. Yardage shown must be used.

See terms and conditions for contrasting upholstery and welt upcharges.

- A) One fabric or leather for seat cushion and back cushion
yardage: 11.0 yds. leather: 162.0 sq. ft.
- B) One fabric or leather for body
yardage: 7.75 yds. leather: 110.0 sq. ft.
- C) One fabric or leather for welt and/or buttons
yardage: 1.75 yds. leather: 20.0 sq. ft.

**Cushion upcharge: B & C cushion add \$200. D & E cushion add \$400.

SCS Indoor Advantage™ Gold and LEVEL® 2 certified. See terms and conditions for additional finish and environmental information.

Seat Height	Arm Height	W	D	H	Fabric	Leather	Weight	Cubes/Qty
17½"	24 1/2	89½"	34"	29¼"	18.5 yds.	300.0'	128 lbs.	40.0'/1
445 mm	622 mm	2273 mm	864 mm	756 mm	10.5 m	17.3 sqm	58.2 kg	1.13 cu.

COM	COL	1	2	3	4	5	6	7	8	9	10	11
5159	5529	6886	7174	7338	7667	7955	8078	8284	8572	8818	9106	10751

sku	cushion type	cushion stitching options		metal leg	metal finish code	wood leg	wood species	wood finish code
<input type="text"/>	1 radius cushions 2 square cushions	A standard B with welt** C tufted**	D tufted with welt** E quilted** **cushion upcharges	A round B square C bevel D ballet	Z bronze K black P polished B brushed	H bevel I conical J incline K block	E maple 9 walnut	see seating finishes
<input type="text"/>	<input type="text"/>	<input type="text"/>	<input type="text"/>	<input type="text"/>	<input type="text"/>	<input type="text"/>	<input type="text"/>	<input type="text"/>

Choose: metal leg/metal finish code or wood leg/wood species.

classic grande

classic grande K2G

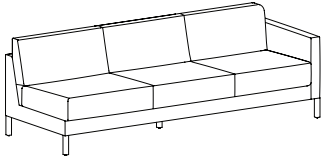

Right side facing sofa
Upholstered

All necessary ganging brackets are included and pre-installed

Not intended for freestanding purposes due to unfinished ends. When being used as freestanding, contact Bernhardt Design for pricing. Radius cushions are not available on freestanding K2G.

Metal or wood legs. Wood legs available in all maple and walnut finishes. When specifying light finishes the natural characteristics of the wood will be visible and color will vary.

When using a combination of fabrics or leathers, specify the application by designating the appropriate letter, shown below, on the purchase order. Yardage shown must be used.

See terms and conditions for contrasting upholstery and welt upcharges.

- A) One fabric or leather for seat cushion and back cushion
yardage: 11.0 yds. leather: 162.0 sq. ft.
- B) One fabric or leather for body
yardage: 7.75 yds. leather: 110.0 sq. ft.
- C) One fabric or leather for welt and/or buttons
yardage: 1.75 yds. leather: 20.0 sq. ft.

**Cushion upcharge: B & C cushion add \$200. D & E cushion add \$400.

SCS Indoor Advantage™ Gold and LEVEL® 2 certified. See terms and conditions for additional finish and environmental information.

Seat Height	Arm Height	W	D	H	Fabric	Leather	Weight	Cubes/Qty
17½"	24½"	89½"	34"	29¾"	18.5 yds.	300.0'	27.9 sqm	61.33'/1
445 mm	622 mm	2273 mm	864 mm	756 mm	16.9 m	27.9 sqm	79.1 kg	1.74 cu.

COM	COL	1	2	3	4	5	6	7	8	9	10	11
5159	5529	6886	7174	7338	7667	7955	8078	8284	8572	8818	9106	10751

sku	cushion type	cushion stitching options	metal leg	metal finish code	wood leg	wood species	wood finish code
<input type="text"/>	1 radius cushions 2 square cushions	A standard B with welt** C tufted** D tufted with welt** E quilted** **cushion upcharges	A round B square C bevel D ballet	Z bronze K black P polished B brushed	H bevel I conical J incline K block	E maple 9 walnut	see seating finishes
<input type="text"/>	<input type="text"/>	<input type="text"/>	<input type="text"/>	<input type="text"/>	<input type="text"/>	<input type="text"/>	<input type="text"/>

Choose: metal leg/metal finish code or wood leg/wood species.

classic grande

classic grande K2L

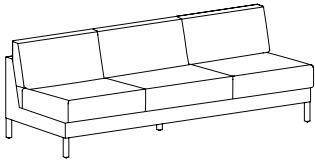

**Armless sofa
Upholstered**

All necessary ganging brackets are included and pre-installed

Not intended for freestanding purposes due to unfinished ends. When being used as freestanding, contact Bernhardt Design for pricing. Radius cushions are not available on freestanding K2L.

Metal or wood legs. Wood legs available in all maple and walnut finishes. When specifying light finishes the natural characteristics of the wood will be visible and color will vary.

When using a combination of fabrics or leathers, specify the application by designating the appropriate letter, shown below, on the purchase order. Yardage shown must be used.

See terms and conditions for contrasting upholstery and welt upcharges.

- A) One fabric or leather for seat cushion and back cushion
yardage: 11.0 yds. leather: 162.0 sq. ft.
- B) One fabric or leather for body
yardage: 6.75 yds. leather: 95.0 sq. ft.
- C) One fabric or leather for welt and/or buttons
yardage: 1.75 yds. leather: 20.0 sq. ft.

**Cushion upcharge: B & C cushion add \$200. D & E cushion add \$400.

SCS Indoor Advantage™ Gold and LEVEL® 2 certified. See terms and conditions for additional finish and environmental information.

Seat Height	Arm Height	W	D	H	Fabric	Leather	Weight	Cubes/Qty
17½"		86"	34"	29¼"	17 yds.	275.0'	163 lbs.	58.67/1
445 mm		2185 mm	864 mm	756 mm	15.6 m	25.6 sqm	74.0 kg	1.7 cu.

COM	COL	1	2	3	4	5	6	7	8	9	10	11
4717	5057	6304	6569	6720	7022	7286	7400	7589	7853	8080	8344	9855

sku	cushion type	cushion stitching options	metal leg	metal finish code	wood leg	wood species	wood finish code
<input type="text"/>	1 radius cushions 2 square cushions	A standard B with welt** C tufted** D tufted with welt** E quilted** **cushion upcharges	A round B square C bevel D ballet	Z bronze K black P polished B brushed	H bevel I conical J incline K block	E maple 9 walnut	see seating finishes
<input type="text"/>	<input type="text"/>	<input type="text"/>	<input type="text"/>	<input type="text"/>	<input type="text"/>	<input type="text"/>	<input type="text"/>

Choose: metal leg/metal finish code or wood leg/wood species.

classic grande

classic grande K2H

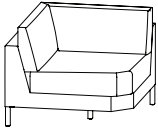

**Classic grande
Square corner
Upholstered**

All necessary ganging brackets are included and pre-installed

Not intended for freestanding purposes due to unfinished ends. When being used as freestanding, contact Bernhardt Design for pricing. Radius cushions are not available on freestanding K2H.

Metal or wood legs. Wodo legs available in all maple and walnut finishes. When specifying light finishes the natural characteristics of the wood will be visible and color will vary.

When using a combination of fabrics or leathers, specify the application by designating the appropriate letter, shown below, on the purchase order. Yardage shown must be used.

See terms and conditions for contrasting upholstery and welt upcharges.

- A) One fabric or leather for seat cushion and back cushion
yardage: 5.1 yds. leather: 82.0 sq. ft.
- B) One fabric or leather for body
yardage: 3.75 yds. leather: 60.0 sq. ft.
- C) One fabric or leather for welt and/or buttons
yardage: 1.0 yds. leather: 10.0 sq. ft.

**Cushion upcharge: B & C cushion add \$150. D & E cushion add \$300.

SCS Indoor Advantage™ Gold and LEVEL® 2 certified. See terms and conditions for additional finish and environmental information.

Seat Height	Arm Height	W	D	H	Fabric	Leather	Weight	Cubes/Qty
17½"	-	37"	37"	29¾"	8.75 yds.	145.0'	102 lbs.	32.67/1
445 mm	-	940 mm	940 mm	756 mm	8.0 m	13.5 sqm	46.4 kg	.93 cu.

COM	COL	1	2	3	4	5	6	7	8	9	10	11
3539	3714	4356	4492	4570	4726	4862	4920	5017	5153	5270	5406	6184

sku	cushion type	cushion stitching options		metal leg	metal finish code	wood leg	wood species	wood finish code
_____	1 radius cushions 2 square cushions	A standard B with welt** C tufted**	D tufted with welt** E quilted** **cushion upcharges	A round B square C bevel D ballet	Z bronze K black P polished B brushed	H bevel I conical J incline K block	E maple 9 walnut	see seating finishes
_____	_____	_____	_____	_____	_____	_____	_____	_____

Choose: metal leg/metal finish code or wood leg/wood species.

classic grande

classic grande K2I



**Curved 45° connector
Upholstered**

All necessary ganging brackets are included and pre-installed

Not intended for freestanding purposes due to unfinished ends. When being used as freestanding, contact Bernhardt Design for pricing. Radius cushions are not available on freestanding K2I.

Metal or wood legs. Wood legs available in all maple and walnut finishes. When specifying light finishes the natural characteristics of the wood will be visible and color will vary.

When using a combination of fabrics or leathers, specify the application by designating the appropriate letter, shown below, on the purchase order. Yardage shown must be used.

See terms and conditions for contrasting upholstery and welt upcharges.

- A) One fabric or leather for seat cushion and back cushion
yardage: 4.25 yds. leather: 65.0 sq. ft.
- B) One fabric or leather for body
yardage: 2.5 yds. leather: 35.0 sq. ft.
- C) One fabric or leather for welt and/or buttons
yardage: 1.0 yds. leather: 10.0 sq. ft.

**Cushion upcharge: B & C cushion add \$150. D & E cushion add \$300.

SCS Indoor Advantage™ Gold and LEVEL® 2 certified. See terms and conditions for additional finish and environmental information.

Seat Height	Arm Height	W	D	H	Fabric	Leather	Weight	Cubes/Qty
17½"	-	44¼"	35 3/4"	29¾"	6.8 yds.	110.0'	65 lbs.	33.78'/1
445 mm	-	1124 mm	908 mm	756 mm	6.2 m	10.2 sqm	29.5 kg	.96 cu.

COM	COL	1	2	3	4	5	6	7	8	9	10	11
3243	3379	3878	3984	4044	4165	4271	4316	4392	4498	4588	4694	5299

sku	cushion type	cushion stitching options	metal leg	metal finish code	wood leg	wood species	wood finish code
_____	1 radius cushions 2 square cushions	A standard D tufted with welt** B with welt** E quilted** C tufted** **cushion upcharges	A round B square C bevel D ballet	Z bronze K black P polished B brushed	H bevel I conical J incline K block	E maple 9 walnut	see seating finishes
_____	_____	_____	_____	_____	_____	_____	_____

Choose: metal leg/metal finish code or wood leg/wood species.

classic grande

classic grande K2J

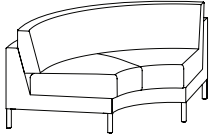

**Curved 90° connector
Upholstered**

All necessary ganging brackets are included and pre-installed

Not intended for freestanding purposes due to unfinished ends. When being used as freestanding, contact Bernhardt Design for pricing. Radius cushions are not available on freestanding K2J.

Metal or wood legs. Wood legs available in all maple and walnut finishes. When specifying light finishes the natural characteristics of the wood will be visible and color will vary.

When using a combination of fabrics or leathers, specify the application by designating the appropriate letter, shown below, on the purchase order. Yardage shown must be used.

See terms and conditions for contrasting upholstery and welt upcharges.

- A) One fabric or leather for seat cushion and back cushion
yardage: 7.25 yds. leather: 110.0 sq. ft.
- B) One fabric or leather for body
yardage: 3.75 yds. leather: 60.0 sq. ft.
- C) One fabric or leather for welt and/or buttons
yardage: 1.0 yds. leather: 10.0 sq. ft.

**Cushion upcharge: B & C cushion add \$150. D & E cushion add \$300.

SCS Indoor Advantage™ Gold and LEVEL® 2 certified. See terms and conditions for additional finish and environmental information.

Seat Height	Arm Height	W	D	H	Fabric	Leather	Weight	Cubes/Qty
17½"	-	70½"	38¾"	29¾"	11.0 yds.	178.0'	155 lbs.	56.94'/1
445 mm	-	1791 mm	981 mm	756 mm	10.1 m	16.5 sqm	70.5 kg	1.61 cu.

COM	COL	1	2	3	4	5	6	7	8	9	10	11
4277	4497	5304	5475	5573	5769	5940	6013	6135	6306	6453	6624	7602

sku	cushion type	cushion stitching options	metal leg	metal finish code	wood leg	wood species	wood finish code
<input type="text"/>	1 radius cushions 2 square cushions	A standard B with welt** C tufted** D tufted with welt** E quilted** **cushion upcharges	A round B square C bevel D ballet	Z bronze K black P polished B brushed	H bevel I conical J incline K block	E maple 9 walnut	see seating finishes
<input type="text"/>	<input type="text"/>	<input type="text"/>	<input type="text"/>	<input type="text"/>	<input type="text"/>	<input type="text"/>	<input type="text"/>

Choose: metal leg/metal finish code or wood leg/wood species.

luxé

luxé K3A

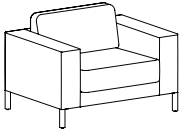

Chair Upholstered

Metal or wood legs. Wood legs available in all maple and walnut finishes. When specifying light finishes the natural characteristics of the wood will be visible and color will vary.

When using a combination of fabrics or leathers, specify the application by designating the appropriate letter, shown below, on the purchase order. Yardage shown must be used.

See terms and conditions for contrasting upholstery and welt upcharges.

- A) One fabric or leather for seat cushion and back cushion
yardage: 4.5 yds. leather: 75.0 sq. ft.
- B) One fabric or leather for body
yardage: 4.5 yds. leather: 75.0 sq. ft.
- C) One fabric or leather for welt and/or buttons on cushions
yardage: 1.0 yds. leather: 10.0 sq. ft.

**Cushion upcharge: B & C cushion add \$100. D & E cushion add \$200.

SCS Indoor Advantage™ Gold and LEVEL® 1 certified. See terms and conditions for additional finish and environmental information.

Seat Height	Arm Height	W	D	H	Fabric	Leather	Weight	Cubes/Qty
17½"	24 ½"	43¼"	34"	29¼"	8.0 yds.	130.0'	110 lbs.	30.61'/1
445 mm	622 mm	921 mm	864 mm	756 mm	7.3 m	12.0 sqm	50.0 kg	.87 cu.

COM	COL	1	2	3	4	5	6	7	8	9	10	11
2948	3108	3695	3820	3891	4033	4157	4211	4300	4424	4531	4655	5366

sku	cushion type	cushion stitching options	metal leg	metal finish code	wood leg	wood species	wood finish code
<input type="text"/>	1 radius cushions 2 square cushions	A standard B with welt** C tufted** D tufted with welt** E quilted** **cushion upcharges	A round B square C bevel D ballet	Z bronze K black P polished B brushed	H bevel I conical J incline K block	E maple 9 walnut	see seating finishes

Choose: metal leg/metal finish code or wood leg/wood species.

luxé

luxé K3B

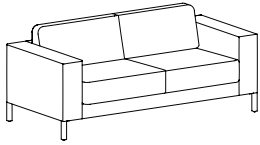

Loveseat Upholstered

Metal or wood legs. Wood legs available in all maple and walnut finishes. When specifying light finishes the natural characteristics of the wood will be visible and color will vary.

When using a combination of fabrics or leathers, specify the application by designating the appropriate letter, shown below, on the purchase order. Yardage shown must be used.

See terms and conditions for contrasting upholstery and welt upcharges.

- A) One fabric or leather for seat cushion and back cushion
yardage: 7.5 yds. leather: 121.0 sq. ft.
- B) One fabric or leather for body
yardage: 7.5 yds. leather: 121.0 sq. ft.
- C) One fabric or leather for welt and/or buttons on cushions
yardage: 1.5 yds. leather: 15.0 sq. ft.

**Cushion upcharge: B & C cushion add \$150. D & E cushion add \$300.

SCS Indoor Advantage™ Gold and LEVEL® 1 certified. See terms and conditions for additional finish and environmental information.

Seat Height	Arm Height	W	H	D	Fabric	Leather	Weight	Cubes/Qty
17½"	24 ½"	71¼"	29¾"	34"	14.5 yds.	235.0'	144 lbs.	49.33'/1
445 mm	622 mm	1822 mm	864 mm	756 mm	13.3 m	21.8 sqm	65.5 kg	1.4 cu.

COM	COL	1	2	3	4	5	6	7	8	9	10	11
4717	5007	6071	6296	6425	6683	6909	7005	7166	7392	7585	7811	9100

sku	cushion type	cushion stitching options		metal leg	metal finish code	wood leg	wood species	wood finish code
<input type="text"/>	1 radius cushions 2 square cushions	A standard B with welt** C tufted**	D tufted with welt** E quilted** **cushion upcharges	A round B square C bevel D ballet	Z bronze K black P polished B brushed	H bevel I conical J incline K block	E maple 9 walnut	see seating finishes
<input type="text"/>	<input type="text"/>	<input type="text"/>	<input type="text"/>	<input type="text"/>	<input type="text"/>	<input type="text"/>	<input type="text"/>	<input type="text"/>

Choose: metal leg/metal finish code or wood leg/wood species.

luxé

luxé K3C

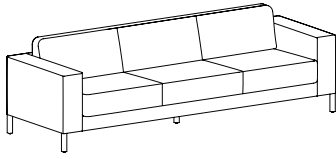

Sofa Upholstered

Metal or wood legs. Wood legs available in all maple and walnut finishes. When specifying light finishes the natural characteristics of the wood will be visible and color will vary.

When using a combination of fabrics or leathers, specify the application by designating the appropriate letter, shown below, on the purchase order. Yardage shown must be used.

See terms and conditions for contrasting upholstery and welt upcharges.

- A) One fabric or leather for seat cushion and back cushion
yardage: 11.0 yds. leather: 178.0 sq. ft.
- B) One fabric or leather for body
yardage: 9.25 yds. leather: 150.0 sq. ft.
- C) One fabric or leather for welt and/or buttons on cushions
yardage: 1.75 yds. leather: 20.0 sq. ft.

**Cushion upcharge: B & C cushion add \$200. D & E cushion add \$400.

SCS Indoor Advantage™ Gold and LEVEL® 1 certified. See terms and conditions for additional finish and environmental information.

Seat Height	Arm Height	W	D	H	Fabric	Leather	Weight	Cubes/Qty
17½"	24½"	100"	34"	29¾"	19.75 yds.	320.0'	195 lbs.	68.0'/1
445 mm	622 mm	2540 mm	864 mm	756 mm	18.1 m	29.7 sqm	88.6 kg	1.9 cu.

COM	COL	1	2	3	4	5	6	7	8	9	10	11
5895	6290	7739	8046	8222	8573	8880	9012	9231	9538	9802	10109	11864

sku	cushion type	cushion stitching options	metal leg	metal finish code	wood leg	wood species	wood finish code
<input type="text"/>	1 radius cushions 2 square cushions	A standard B with welt** C tufted** D tufted with welt** E quilted** **cushion upcharges	A round B square C bevel D ballet	Z bronze K black P polished B brushed	H bevel I conical J incline K block	E maple 9 walnut	see seating finishes
<input type="text"/>	<input type="text"/>	<input type="text"/>	<input type="text"/>	<input type="text"/>	<input type="text"/>	<input type="text"/>	<input type="text"/>

Choose: metal leg/metal finish code or wood leg/wood species.

luxé

luxé K3D

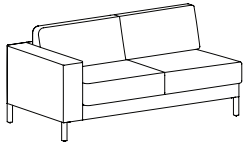

**Left side facing loveseat
Upholstered**

All necessary ganging brackets are included and pre-installed

Not intended for freestanding purposes due to unfinished ends. When being used as freestanding, contact Bernhardt Design for pricing. Radius cushions are not available on freestanding K3D.

Metal or wood legs. Wood legs available in all maple and walnut finishes. When specifying light finishes the natural characteristics of the wood will be visible and color will vary.

When using a combination of fabrics or leathers, specify the application by designating the appropriate letter, shown below, on the purchase order. Yardage shown must be used.

See terms and conditions for contrasting upholstery and welt upcharges.

- A) One fabric or leather for seat cushion and back cushion
yardage: 7.5 yds. leather: 121 sq. ft.
- B) One fabric or leather for body
yardage: 5.75 yds. leather: 95.0 sq. ft.
- C) One fabric or leather for welt and/or buttons on cushions
yardage: 1.5 yds. leather: 15.0 sq. ft.

**Cushion upcharge: B & C cushion add \$150. D & E cushion add \$300.

SCS Indoor Advantage™ Gold and LEVEL® 1 certified. See terms and conditions for additional finish and environmental information.

Seat Height	Arm Height	W	D	H	Fabric	Leather	Weight	Cubes/Qty
17½"	24½"	64½"	34"	29¾"	13.0 yds.	210.0'	139 lbs.	45.33'/1
445 mm	622 mm	1638 mm	864 mm	756 mm	11.9 m	19.5 sqm	63.2 kg	1.28 cu.

COM	COL	1	2	3	4	5	6	7	8	9	10	11
4277	4537	5491	5693	5809	6040	6242	6329	6473	6675	6849	7051	8206

sku	cushion type	cushion stitching options	metal leg	metal finish code	wood leg	wood species	wood finish code
<input type="text"/>	1 radius cushions 2 square cushions	A standard B with welt** C tufted** D tufted with welt** E quilted** **cushion upcharges	A round B square C bevel D ballet	Z bronze K black P polished B brushed	H bevel I conical J incline K block	E maple 9 walnut	see seating finishes
<input type="text"/>	<input type="text"/>	<input type="text"/>	<input type="text"/>	<input type="text"/>	<input type="text"/>	<input type="text"/>	<input type="text"/>

Choose: metal leg/metal finish code or wood leg/wood species.

luxé

luxé K3E



**Right side facing loveseat
Upholstered**

All necessary ganging brackets are included and pre-installed

Not intended for freestanding purposes due to unfinished ends. When being used as freestanding, contact Bernhardt Design for pricing. Radius cushions are not available on freestanding K3E.

Metal or wood legs. Wood legs available in all maple and walnut finishes. When specifying light finishes the natural characteristics of the wood will be visible and color will vary.

When using a combination of fabrics or leathers, specify the application by designating the appropriate letter, shown below, on the purchase order. Yardage shown must be used.

See terms and conditions for contrasting upholstery and welt upcharges.

- A) One fabric or leather for seat cushion and back cushion
yardage: 7.5 yds. leather: 121 sq. ft.
- B) One fabric or leather for body
yardage: 5.75 yds. leather: 95.0 sq. ft.
- C) One fabric or leather for welt and/or buttons on cushions
yardage: 1.5 yds. leather: 15.0 sq. ft.

**Cushion upcharge: B & C cushion add \$150. D & E cushion add \$300.

SCS Indoor Advantage™ Gold and LEVEL® 2 certified. See terms and conditions for additional finish and environmental information.

Seat Height	Arm Height	W	D	H	Fabric	Leather	Weight	Cubes/Qty
17½"	24½"	64½"	34"	29¾"	13.0 yds.	210.0'	139 lbs.	45.33'/1
445 mm	622 mm	1638 mm	864 mm	756 mm	11.9 m	19.5 sqm	63.2 kg	1.28 cu.

COM	COL	1	2	3	4	5	6	7	8	9	10	11
4277	4537	5491	5693	5809	6040	6242	6329	6473	6675	6849	7051	8206

sku	cushion type	cushion stitching options	metal leg	metal finish code	wood leg	wood species	wood finish code
<input type="text"/>	1 radius cushions 2 square cushions	A standard B with welt** C tufted** D tufted with welt** E quilted** **cushion upcharges	A round B square C bevel D ballet	Z bronze K black P polished B brushed	H bevel I conical J incline K block	E maple 9 walnut	see seating finishes
<input type="text"/>	<input type="text"/>	<input type="text"/>	<input type="text"/>	<input type="text"/>	<input type="text"/>	<input type="text"/>	<input type="text"/>

Choose: metal leg/metal finish code or wood leg/wood species.

luxé

luxé K3K

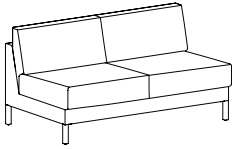

**Armless loveseat
Upholstered**

All necessary ganging brackets are included and pre-installed

Not intended for freestanding purposes due to unfinished ends. When being used as freestanding, contact Bernhardt Design for pricing. Radius cushions are not available on freestanding K3K.

Metal or wood legs. Wood legs available in all maple and walnut finishes. When specifying light finishes the natural characteristics of the wood will be visible and color will vary.

When using a combination of fabrics or leathers, specify the application by designating the appropriate letter, shown below, on the purchase order. Yardage shown must be used.

See terms and conditions for contrasting upholstery and welt upcharges.

- A) One fabric or leather for seat cushion and back cushion
yardage: 7.5 yds. leather: 121 sq. ft.
- B) One fabric or leather for body
yardage: 6.0 yds. leather: 98.0 sq. ft.
- C) One fabric or leather for welt and/or buttons on cushions
yardage: 1.5 yds. leather: 15.0 sq. ft.

**Cushion usspcharge: B & C cushion add \$150. D & E cushion add \$300.

SCS Indoor Advantage™ Gold and LEVEL® 2 certified. See terms and conditions for additional finish and environmental information.

Seat Height	Arm Height	W	D	H	Fabric	Leather	Weight	Cubes/Qty
17½"	-	57½"	34"	29¾"	11.5 yds.	186.0'	128 lbs.	40.0/1
445 mm	-	1461 mm	864 mm	756 mm	10.5 m	17.3 sqm	58.2 kg	1.13 cu.

COM	COL	1	2	3	4	5	6	7	8	9	10	11
3539	3769	4613	4792	4894	5098	5277	5354	5482	5661	5814	5993	7015

sku	cushion type	cushion stitching options	metal leg	metal finish code	wood leg	wood species	wood finish code
<input type="text"/>	1 radius cushions 2 square cushions	A standard B with welt** C tufted** D tufted with welt** E quilted** **cushion upcharges	A round B square C bevel D ballet	Z bronze K black P polished B brushed	H bevel I conical J incline K block	E maple 9 walnut	see seating finishes
<input type="text"/>	<input type="text"/>	<input type="text"/>	<input type="text"/>	<input type="text"/>	<input type="text"/>	<input type="text"/>	<input type="text"/>

Choose: metal leg/metal finish code or wood leg/wood species.

luxé

luxé K3F

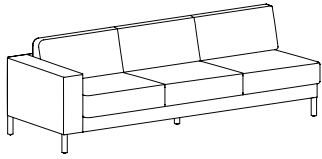

**Left side facing sofa
Upholstered**

All necessary ganging brackets are included and pre-installed

Not intended for freestanding purposes due to unfinished ends. When being used as freestanding, contact Bernhardt Design for pricing. Radius cushions are not available on freestanding K3F.

Metal or wood legs. Wood legs available in all maple and walnut finishes. When specifying light finishes the natural characteristics of the wood will be visible and color will vary.

When using a combination of fabrics or leathers, specify the application by designating the appropriate letter, shown below, on the purchase order. Yardage shown must be used.

See terms and conditions for contrasting upholstery and welt upcharges.

- A) One fabric or leather for seat cushion and back cushion
yardage: 11.0 yds. leather: 178.0 sq. ft.
- B) One fabric or leather for body
yardage: 7.75 yds. leather: 125.0 sq. ft.
- C) One fabric or leather for welt and/or buttons on cushions
yardage: 1.75 yds. leather: 20.0 sq. ft.

**Cushion upcharge: B & C cushion add \$200. D & E cushion add \$400.

SCS Indoor Advantage™ Gold and LEVEL® 2 certified. See terms and conditions for additional finish and environmental information.

Seat Height	Arm Height	W	D	H	Fabric	Leather	Weight	Cubes/Qty
17½"	24½"	93¼"	34"	29¼"	18.5 yds.	300.0'	188 lbs.	64.0'/1
445 mm	622 mm	2369 mm	864 mm	756 mm	16.9 m	27.9 sqm	85.5 kg	1.81 cu.

COM	COL	1	2	3	4	5	6	7	8	9	10	11
5454	5824	7181	7469	7633	7962	8250	8373	8579	8867	9113	9401	11046

sku	cushion type	cushion stitching options	metal leg	metal finish code	wood leg	wood species	wood finish code
<input type="text"/>	1 radius cushions 2 square cushions	A standard B with welt** C tufted** D tufted with welt** E quilted** **cushion upcharges	A round B square C bevel D ballet	Z bronze K black P polished B brushed	H bevel I conical J incline K block	E maple 9 walnut	see seating finishes

Choose: metal leg/metal finish code or wood leg/wood species.

luxé

luxé K3G

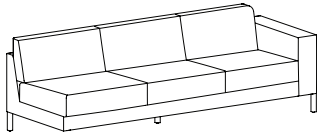

**Right side facing sofa
Upholstered**

All necessary ganging brackets are included and pre-installed

Not intended for freestanding purposes due to unfinished ends. When being used as freestanding, contact Bernhardt Design for pricing. Radius cushions are not available on freestanding K3G.

Metal or wood legs. Wood legs available available in all maple and walnut finishes. When specifying light finishes the natural characteristics of the wood will be visible and color will vary.

When using a combination of fabrics or leathers, the following yardage must be used and upcharges apply. Specify the fabric or leather application by designating the appropriate letter on the purchase order.

See terms and conditions for contrasting fabric and welt upcharges.

- A) One fabric or leather for seat cushion and back cushion
yardage: 11.0 yds. leather: 178.0 sq. ft.
- B) One fabric or leather for body
yardage: 7.75 yds. leather: 125.0 sq. ft.
- C) One fabric or leather for welt and/or buttons on cushions
yardage: 1.75 yds. leather: 20.0 sq. ft.

**Cushion upcharge: B & C cushion add \$200. D & E cushion add \$400.

SCS Indoor Advantage™ Gold and LEVEL® 2 certified. See terms and conditions for additional finish and environmental information.

Seat Height	Arm Height	W	D	H	Fabric	Leather	Weight	Cubes/Qty
17½"	24½"	93¼"	34"	29¼"	18.5 yds.	300.0'	188 lbs.	64.0'/1
445 mm	622 mm	2369 mm	864 mm	756 mm	16.9 m	27.9 sqm	85.5 kg	1.81 cu.

COM	COL	1	2	3	4	5	6	7	8	9	10	11
5454	5824	7181	7469	7633	7962	8250	8373	8579	8867	9113	9401	11046

sku	cushion type	cushion stitching options	metal leg	metal finish code	wood leg	wood species	wood finish code
<input type="text"/>	1 radius cushions 2 square cushions	A standard B with welt** C tufted** D tufted with welt** E quilted** **cushion upcharges	A round B square C bevel D ballet	Z bronze K black P polished B brushed	H bevel I conical J incline K block	E maple 9 walnut	see seating finishes

Choose: metal leg/metal finish code or wood leg/wood species.

luxé

luxé K3L

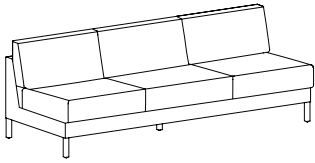

**Armless sofa
Upholstered**

All necessary ganging brackets are included and pre-installed

Not intended for freestanding purposes due to unfinished ends. When being used as freestanding, contact Bernhardt Design for pricing. Radius cushions are not available on freestanding K3L.

Metal or wood legs. Wood legs available in all maple and walnut finishes. When specifying light finishes the natural characteristics of the wood will be visible and color will vary.

When using a combination of fabrics or leathers, the following yardage must be used and upcharges apply. Specify the fabric or leather application by designating the appropriate letter on the purchase order.

See terms and conditions for contrasting fabric and welt upcharges.

- A) One fabric or leather for seat cushion and back cushion
yardage: 11.0 yds. leather: 178.0 sq. ft.
- B) One fabric or leather for body
yardage: 6.75 yds. leather: 110.0 sq. ft.
- C) One fabric or leather for welt and/or buttons on cushions
yardage: 1.75 yds. leather: 20.0 sq. ft.

**Cushion upcharge: B & C cushion add \$200. D & E cushion add \$400.

SCS Indoor Advantage™ Gold and LEVEL® 2 certified. See terms and conditions for additional finish and environmental information.

Seat Height	Arm Height	W	D	H	Fabric	Leather	Weight	Cubes/Qty
17½"	-	86"	34"	29¼"	17.0 yds.	275.0'	163 lbs.	58.67/1
445 mm	-	2184 mm	864 mm	756 mm	15.5 m	25.5 sqm	74.1 kg	1.7 cu.

COM	COL	1	2	3	4	5	6	7	8	9	10	11
4717	5057	6304	6569	6720	7022	7286	7400	7589	7853	8080	8344	9855

sku	cushion type	cushion stitching options		metal leg	metal finish code	wood leg	wood species	wood finish code
<input type="text"/>	1 radius cushions 2 square cushions	A standard B with welt** C tufted**	D tufted with welt** E quilted** **cushion upcharges	A round B square C bevel D ballet	Z bronze K black P polished B brushed	H bevel I conical J incline K block	E maple 9 walnut	see seating finishes
<input type="text"/>	<input type="text"/>	<input type="text"/>	<input type="text"/>	<input type="text"/>	<input type="text"/>	<input type="text"/>	<input type="text"/>	<input type="text"/>

Choose: metal leg/metal finish code or wood leg/wood species.

luxé

luxé K3H

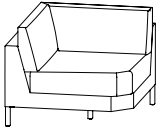

**Square corner chair
Upholstered**

All necessary ganging brackets are included and pre-installed

Not intended for freestanding purposes due to unfinished ends. When being used as freestanding, contact Bernhardt Design for pricing. Radius cushions are not available on freestanding K3H.

Metal or wood legs. Wood legs available in all maple and walnut finishes. When specifying light finishes the natural characteristics of the wood will be visible and color will vary.

When using a combination of fabrics or leathers, the following yardage must be used and upcharges apply. Specify the fabric or leather application by designating the appropriate letter on the purchase order.

See terms and conditions for contrasting fabric and welt upcharges.

- A) One fabric or leather for seat cushion and back cushion
yardage: 5.1 yds. leather: 82.0 sq. ft.
- B) One fabric or leather for body
yardage: 3.75 yds. leather: 60.0 sq. ft.
- C) One fabric or leather for welt and/or buttons
yardage: 1.0 yds leather: 10.0 sq. ft.

*Cushion upcharge: B & C cushion add \$150. D & E cushion add \$300.

SCS Indoor Advantage™ Gold and LEVEL® 2 certified. See terms and conditions for additional finish and environmental information.

Seat Height	Arm Height	W	D	H	Fabric	Leather	Weight	Cubes/Qty
17½"	-	37"	37"	29¾"	8.75 yds.	145.0'	102 lbs.	32.67/1
445 mm	-	940 mm	940 mm	756 mm	8.0 m	13.5 sqm	46.4 kg	.93 cu.

COM	COL	1	2	3	4	5	6	7	8	9	10	11
3539	3714	4356	4492	4570	4726	4862	4920	5017	5153	5270	5406	6184

sku	cushion type	cushion stitching options	metal leg	metal finish code	wood leg	wood species	wood finish code
<input type="text"/>	1 radius cushions 2 square cushions	A standard D tufted with welt** B with welt** E quilted** C tufted** **cushion upcharges	A round B square C bevel D ballet	Z bronze K black P polished B brushed	H bevel I conical J incline K block	E maple 9 walnut	see seating finishes
<input type="text"/>	<input type="text"/>	<input type="text"/>	<input type="text"/>	<input type="text"/>	<input type="text"/>	<input type="text"/>	<input type="text"/>

Choose: metal leg/metal finish code or wood leg/wood species.

luxé

luxé K3I

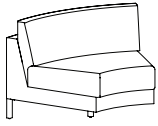

**Curved 45° connector
Upholstered**

All necessary ganging brackets are included and pre-installed

Not intended for freestanding purposes due to unfinished ends. When being used as freestanding, contact Bernhardt Design for pricing. Radius cushions are not available on freestanding K3I.

Metal or wood legs. Woodlegs available in all maple and walnut finishes. When specifying light finishes the natural characteristics of the wood will be visible and color will vary.

When using a combination of fabrics or leathers, specify the application by designating the appropriate letter, shown below, on the purchase order. Yardage shown must be used.

See terms and conditions for contrasting upholstery and welt upcharges.

- A) One fabric or leather for seat cushion and back cushion
yardage: 4.25 yds. leather: 70.0 sq. ft.
- B) One fabric or leather for body
yardage: 3.5 yds. leather: 56.0 sq. ft.
- C) One fabric or leather for welt and/or buttons
yardage: 1.0 yds. leather: 10.0 sq. ft.

**Cushion upcharge: B & C cushion add \$150. D & E cushion add \$300.

SCS Indoor Advantage™ Gold and LEVEL® 2 certified. See terms and conditions for additional finish and environmental information.

Seat Height	Arm Height	W	D	H	Fabric	Leather	Weight	Cubes/Qty
17½"	-	44 1/4"	29 3/4"	35 3/4"	6.8 yds.	110.0'	102 lbs.	33.78'/1
445 mm	-	1124 mm	908 mm	756 mm	15.5 m	10.3 sqm	46.4 kg	1.7 cu.

COM	COL	1	2	3	4	5	6	7	8	9	10	11
3243	3379	3878	3984	4044	4165	4271	4316	4392	4498	4588	4694	5299

sku	cushion type	cushion stitching options	metal leg	metal finish code	wood leg	wood species	wood finish code
<input type="text"/>	1 radius cushions 2 square cushions	A standard B with welt** C tufted** D tufted with welt** E quilted** **cushion upcharges	A round B square C bevel D ballet	Z bronze K black P polished B brushed	H bevel I conical J incline K block	E maple 9 walnut	see seating finishes

Choose: metal leg/metal finish code or wood leg/wood species.

luxé

luxé K3J

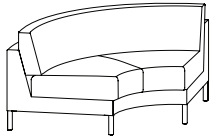

**Curved 90° connector
Upholstered**

All necessary ganging brackets are included and pre-installed

Not intended for freestanding purposes due to unfinished ends. When being used as freestanding, contact Bernhardt Design for pricing. Radius cushions are not available on freestanding K3J.

Metal or wood legs. Wood legs available in all maple and walnut finishes. When specifying light finishes the natural characteristics of the wood will be visible and color will vary.

When using a combination of fabrics or leathers, specify the application by designating the appropriate letter, shown below, on the purchase order. Yardage shown must be used.

See terms and conditions for contrasting upholstery and welt upcharges.

- A) One fabric or leather for seat cushion and back cushion
yardage: 7.25 yds. leather: 118.0 sq. ft.
- B) One fabric or leather for body
yardage: 5.0 yds. leather: 81.0 sq. ft.
- C) One fabric or leather for welt and/or buttons on cushions
yardage: 1.0 yds. leather: 10.0 sq. ft.

**Cushion upcharge: B & C cushion add \$150. D & E cushion add \$300.

SCS Indoor Advantage™ Gold and LEVEL® 2 certified. See terms and conditions for additional finish and environmental information.

Seat Height	Arm Height	W	D	H	Fabric	Leather	Weight	Cubes/Qty
17½"	-	70½"	38½"	29¾"	11.0 yds.	178.0'	155 lbs.	56.94'/1
445 mm	-	1791mm	981 mm	756 mm	10.1 m	14.9 sqm	70.3 kg	1.51 cu.

COM	COL	1	2	3	4	5	6	7	8	9	10	11
4277	4497	5304	5475	5573	5769	5940	6013	6135	6306	6453	6624	7602

sku	cushion type	cushion stitching options		metal leg	metal finish code	wood leg	wood species	wood finish code
<input type="text"/>	1 radius cushions 2 square cushions	A standard B with welt** C tufted**	D tufted with welt** E quilted** **cushion upcharges	A round B square C bevel D ballet	Z bronze K black P polished B brushed	H bevel I conical J incline K block	E maple 9 walnut	see seating finishes
<input type="text"/>	<input type="text"/>	<input type="text"/>	<input type="text"/>	<input type="text"/>	<input type="text"/>	<input type="text"/>	<input type="text"/>	<input type="text"/>

Choose: metal leg/metal finish code or wood leg/wood species.

classic compact

classic compact K6A

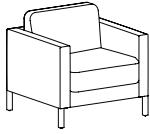

**Classic compact
Chair
Upholstered**

Metal or wood legs. Wood legs available in all maple and walnut finishes. When specifying light finishes the natural characteristics of the wood will be visible and color will vary.

When using a combination of fabrics or leathers, specify the application by designating the appropriate letter, shown below, on the purchase order. Yardage shown must be used.

See terms and conditions for contrasting upholstery and welt upcharges.

- A) One fabric or leather for seat cushion and back cushion
yardage: 3.75 yds. leather: 60.0 sq. ft.
- B) One fabric or leather for body
yardage: 3.75 yds. leather: 60.0 sq. ft.
- C) One fabric or leather for welt and/or buttons
yardage: 1.0 yds. leather: 10.0 sq. ft.

**Cushion upcharge: B & C cushion add \$100. D & E cushion add \$200.

SCS Indoor Advantage™ Gold and LEVEL® 2 certified. See terms and conditions for additional finish and environmental information.

Seat Height	Arm Height	W	D	H	Fabric	Leather	Weight	Cubes/Qty
17½"	24 ½"	31¼"	30¼"	29¾"	7.5 yds.	115.0'	91 lbs.	20.15/1
445 mm	622 mm	794 mm	768 mm	756 mm	6.9 m	10.7 sqm	41.4 kg	.57 cu.

COM	COL	1	2	3	4	5	6	7	8	9	10	11
2508	2658	3208	3325	3392	3525	3642	3692	3775	3892	3992	4108	4775

sku	cushion type	cushion stitching options		metal leg	metal finish code	wood leg	wood species	wood finish code
<input type="text"/>	1 radius cushions 2 square cushions	A standard B with welt** C tufted**	D tufted with welt** E quilted** **cushion upcharges	A round B square C bevel D ballet	Z bronze K black P polished B brushed	H bevel I conical J incline K block	E maple 9 walnut	see seating finishes
<input type="text"/>	<input type="text"/>	<input type="text"/>	<input type="text"/>	<input type="text"/>	<input type="text"/>	<input type="text"/>	<input type="text"/>	<input type="text"/>

Choose: metal leg/metal finish code or wood leg/wood species.

ottomans - benches

harmony K6C

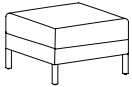

Ottoman Upholstered

Metal or wood legs. Wood legs available in all maple and walnut finishes. When specifying light finishes the natural characteristics of the wood will be visible and color will vary.

When using a combination of fabrics or leathers, specify the application by designating the appropriate letter, shown below, on the purchase order. Yardage shown must be used.

See terms and conditions for contrasting upholstery and welt upcharges.

- A) One fabric or leather for seat cushion and back cushion
yardage: 2.0 yds. leather: 30.0 sq. ft.
- B) One fabric or leather for body
yardage: 1.5 yds. leather: 15.0 sq. ft.
- C) One fabric or leather for welt and/or buttons
yardage: 1.0 yds. leather: 10.0 sq. ft.

**Cushion upcharge: B cushion add \$50. E cushion add \$100.

SCS Indoor Advantage™ Gold and LEVEL® 2 certified. See terms and conditions for instructions for additional finish and environmental information.

Seat Height	Arm Height	W	D	H	Fabric	Leather	Weight	Cubes/Qty
17"	-	26"	26"	17"	3.25 yds.	52.0'	61 lbs.	9.07'/1
432 mm	-	660 mm	660 mm	432 mm	3.0 m	4.8 sqm	57.7 kg	.26 cu.

COM	COL	1	2	3	4	5	6	7	8	9	10	11
1623	1688	1927	1977	2006	2064	2115	2136	2172	2223	2266	2317	2606

sku	cushion type	cushion stitching options	metal leg	metal finish code	wood leg	wood species	wood finish code
<input type="text"/>	2 square cushions	A standard B with welt** E quilted** **cushion upcharges	A round B square C bevel D ballet	Z bronze K black P polished B brushed	H bevel I conical J incline K block	E maple 9 walnut	see seating finishes

Choose: metal leg/metal finish code or wood leg/wood species.

ottomans - benches

harmony K6D

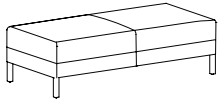

**Two-seat bench
Upholstered**

Metal or wood legs. Wood legs available in all maple and walnut finishes. When specifying light finishes the natural characteristics of the wood will be visible and color will vary.

When using a combination of fabrics or leathers, specify the application by designating the appropriate letter, shown below, on the purchase order. Yardage shown must be used.

See terms and conditions for contrasting upholstery and welt upcharges.

- A) One fabric or leather for seat cushion
yardage: 3.5 yds. leather: 57.0 sq. ft.
- B) One fabric or leather for body
yardage: 2.0 yds. leather: 30.0 sq. ft.
- C) One fabric or leather for welt and/or buttons
yardage: 1.0 yds. leather: 10.0 sq. ft.

**Cushion upcharge: B cushion add \$75. E cushion add \$150.

SCS Indoor Advantage™ Gold and LEVEL® 2 certified. See terms and conditions for instructions for additional finish and environmental information.

Seat Height	Arm Height	W	D	H	Fabric	Leather	Weight	Cubes/Qty
17"	-	56"	26"	17"	5.0 yds.	81.0'	100 lbs.	17.50'/1
432 mm	-	1422 mm	660 mm	432 mm	4.6 m	7.5 sqm	45.5 kg	.50 cu.

COM	COL	1	2	3	4	5	6	7	8	9	10	11
2360	2460	2827	2905	2949	3038	3116	3149	3205	3283	3349	3427	3872

sku	cushion type	cushion stitching options	metal leg	metal finish code	wood leg	wood species	wood finish code
<input type="text"/>	2 square cushions	A standard B with welt** E quilted** **cushion upcharges	A round B square C bevel D ballet	Z bronze K black P polished B brushed	H bevel I conical J incline K block	E maple 9 walnut	see seating finishes

Choose: metal leg/metal finish code or wood leg/wood species.

ottomans - benches

harmony K6E

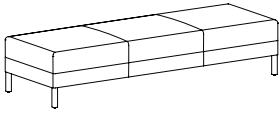

**Three-seat bench
Upholstered**

Metal or wood legs. Wood legs available in all maple and walnut finishes. When specifying light finishes the natural characteristics of the wood will be visible and color will vary.

When using a combination of fabrics or leathers, specify the application by designating the appropriate letter, shown below, on the purchase order. Yardage shown must be used.

See terms and conditions for contrasting upholstery and welt upcharges.

- A) One fabric or leather for seat cushion
yardage: 5.0 yds. leather: 80.0 sq. ft.
- B) One fabric or leather for body
yardage: 2.75 yds. leather: 45.0 sq. ft.
- C) One fabric or leather for welt and/or buttons
yardage: 1.0 yds. leather: 10.0 sq. ft.

**Cushion upcharge: B cushion add \$100. E cushion add \$200.

SCS Indoor Advantage™ Gold and LEVEL® 2 certified. See terms and conditions for instructions for additional finish and environmental information.

Seat Height	Arm Height	W	H	D	Fabric	Leather	Weight	Cubes/Qty
17"	-	78"	17"	26"	6.75 yds.	110.0'	133 lbs.	25.93'/1
432 mm	-	1981 mm	660 mm	432 mm	6.2 m	10.2 sqm	60.5 kg	.73 cu.

COM	COL	1	2	3	4	5	6	7	8	9	10	11
2657	2792	3287	3392	3452	3572	3677	3722	3797	3902	3992	4097	4697

sku	cushion type	cushion stitching options	metal leg	metal finish code	wood leg	wood species	wood finish code
<input type="text"/>	2 square cushions	A standard B with welt** E quilted** **cushion upcharges	A round B square C bevel D ballet	Z bronze K black P polished B brushed	H bevel I conical J incline K block	E maple 9 walnut	see seating finishes

Choose: metal leg/metal finish code or wood leg/wood species.

Item Seating System Specification Guide

Item seating modules are fully upholstered and are designed to create freefloating design configurations. Item modules twist, rise and fall in their design creating a final assembly sculptured from both the plan and elevation views. Item is offered in 10 different modules that range in shape and heights. Variations in heights within the item modular group makes it necessary to use only the modules with corresponding heights together. Modules cannot be mated to either A or D sides.

All necessary ganging brackets are included and pre-installed. Fabric on corner module will be railroaded. If modules are used in a configuration with the corner module, specify fabric railroaded. When ordering multi-item configurations, please provide the total COM yardage from the same dye lot in a continuous roll(s). SCS Indoor Advantage™ Gold and LEVEL® 2 certified. See terms and conditions for additional environmental information.

Illustration showing ONLY the low lounge modules for Item.

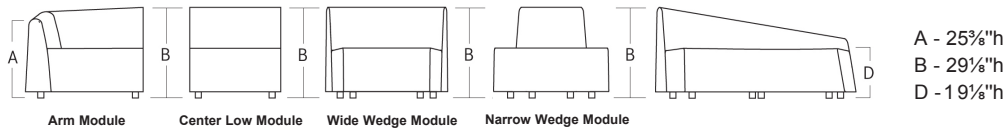
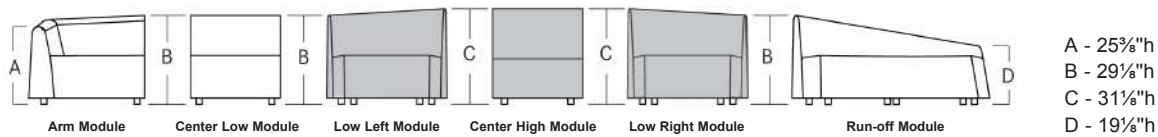

Illustration showing both the low and the taller transition modules for Item.

Item's change in height adds to the palette of creativity that already exists within the sectional group. Shaded modules show the tall and transitional modules. Note: Tall and low modules must be paired with a unit with a matching height. The "C" height will only fit to other "C" height modules as the "B" height will only work with corresponding "B" height units.



Item Seating System Sample Configurations

		SKU	Description
1		5900L 5900R	Left Arm Module Right Arm Module
2		5900L 5901CL 5900R	Left Arm Module Center Low Module Right Arm Module
3		5900L 5902NW 5900R	Left Arm Module Narrow Back Wedge (3) Right Arm Module

Item Seating System Sample Configurations

		SKU	Description
4		5900L 5902WW 5900R	Left Arm Module Wide Wedge Module (4) Right Arm Module
5		5900L 5901CL 5904R	Left Arm Module Center Low Module Run-off Right Module
6		5900L 5901CL 5905 5901CL 5900R	Left Arm Module Center Low Module Corner Module Center Low Module Right Arm Module
7		5900L 5902NW 5904R	Left Arm Module Narrow Back Wedge (2) Run-off Right Module
8		5900L 5903LW 5901CH 5903RW 5902NW 5904R	Left Corner Module Low Left Wedge Module Center High Module Low Right Wedge Module Narrow Back Wedge Module (2) Run-Off Right Module
9		5900L 5901CL 5903RW 5903RW 5900R	Left Corner Module Center Low Module Low Right Wedge Module Low Right Wedge Module Right Corner Module
10		5900L 5903LW 5901CH 5903RW 5900R	Left Corner Module Low Left Wedge Module Center High Module Low Right Wedge Module Right Corner Module

item 5900L

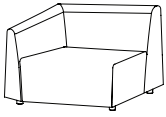

**Left arm module
Fully upholstered**

All necessary ganging brackets are included and pre-installed

Specify fabric railroaded when used with item 5905 corner module.

SCS Indoor Advantage™ Gold and LEVEL® 2 certified. See terms and conditions for additional environmental information.

Seat Height	Arm Height	W	D	H	Fabric	Leather	Weight	Cubes/Qty
16¾"	25½"	38"	42¾"	29½"	5.8 yds.	101.0'	105 lbs.	32.10'/1
425 mm	645 mm	965 mm	1076 mm	740 mm	5.3 m	9.4 sqm	47.6 kg	.91 cu.

COM	COL	1	2	3	4	5	6	7	8	9	10	11
3130	3246	3672	3762	3814	3917	4007	4046	4110	4200	4278	4368	4883

item 5900R

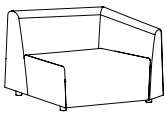

**Right arm module
Fully upholstered**

All necessary ganging brackets are included and pre-installed

Specify fabric railroaded when used with item 5905 corner module.

SCS Indoor Advantage™ Gold and LEVEL® 2 certified. See terms and conditions for additional environmental information.

Seat Height	Arm Height	W	D	H	Fabric	Leather	Weight	Cubes/Qty
16¾"	25½"	38"	42¾"	29½"	5.8 yds.	101.0'	105 lbs.	32.10'/1
425 mm	645 mm	965 mm	1076 mm	740 mm	5.3 m	9.4 sqm	47.6 kg	.91 cu.

COM	COL	1	2	3	4	5	6	7	8	9	10	11
3130	3246	3672	3762	3814	3917	4007	4046	4110	4200	4278	4368	4883

item 5901CL



**Center low module
Fully upholstered**

All necessary ganging brackets are included and pre-installed

Specify fabric railroaded when used with item 5905 corner module.

SCS Indoor Advantage™ Gold and LEVEL® 2 certified. See terms and conditions for additional environmental information.

Seat Height	Arm Height	W	D	H	Fabric	Leather	Weight	Cubes/Qty
16¾"	-	29½"	37¼"	29½"	4.8 yds.	87.0'	85 lbs.	32.10'/1
425 mm	-	750 mm	946 mm	740 mm	4.4 m	8.1 sqm	38.5 kg	.91 cu.

COM	COL	1	2	3	4	5	6	7	8	9	10	11
2157	2253	2605	2680	2723	2808	2883	2915	2968	3043	3107	3181	3608

item 5902WW

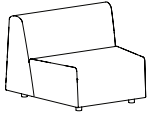

**Wide back wedge module
Fully upholstered**

All necessary ganging brackets are included and pre-installed

Specify fabric railroaded when used with item 5905 corner module.

SCS Indoor Advantage™ Gold and LEVEL® 2 certified. See terms and conditions for additional environmental information.

Seat Height	Arm Height	W	D	H	Fabric	Leather	Weight	Cubes/Qty
16¾"	-	38"	36⅝"	29⅞"	4.8 yds.	87.0'	85 lbs.	32.10'/1
425 mm	-	965 mm	930 mm	740 mm	4.4 m	8.1 sqm	38.5 kg	.91 cu.

COM	COL	1	2	3	4	5	6	7	8	9	10	11
2157	2253	2605	2680	2723	2808	2883	2915	2968	3043	3107	3181	3608

item 5902NW

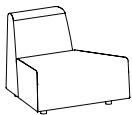

**Narrow back wedge module
Fully upholstered**

All necessary ganging brackets are included and pre-installed

Specify fabric railroaded when used with item 5905 corner module.

SCS Indoor Advantage™ Gold and LEVEL® 2 certified. See terms and conditions for additional environmental information.

Seat Height	Arm Height	W	D	H	Fabric	Leather	Weight	Cubes/Qty
16¾"	-	37¼"	35¼"	29⅞"	4.5 yds.	87.0'	75 lbs.	32.10'/1
425 mm	-	946 mm	908 mm	740 mm	4.2 m	8.1 sqm	38.5 kg	32.10'/1

COM	COL	1	2	3	4	5	6	7	8	9	10	11
2157	2247	2577	2647	2687	2767	2837	2867	2917	2987	3047	3117	3517

item 5904L

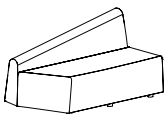

**Run-off left module
Fully upholstered**

All necessary ganging brackets are included and pre-installed

Specify fabric railroaded when used with item 5905 corner module.

SCS Indoor Advantage™ Gold and LEVEL® 2 certified. See terms and conditions for additional environmental information.

Seat Height	Arm Height	W	D	H	Fabric	Leather	Weight	Cubes/Qty
16¾"	-	64¼"	36⅝"	29⅞"	7.5 yds.	116.0'	121 lbs.	68.33'/1
425 mm	-	1632 mm	918 mm	740 mm	6.9 m	10.8 sqm	54.9 kg	1.93 cu.

COM	COL	1	2	3	4	5	6	7	8	9	10	11
3130	3280	3830	3947	4014	4147	4264	4314	4397	4514	4614	4730	5397

item 5904R

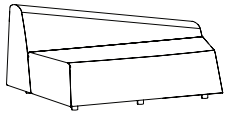

**Run-off right module
Fully upholstered**

All necessary ganging brackets are included and pre-installed

Specify fabric railroaded when used with item 5905 corner module.

SCS Indoor Advantage™ Gold and LEVEL® 2 certified. See terms and conditions for additional environmental information.

Seat Height	Arm Height	W	D	H	Fabric	Leather	Weight	Cubes/Qty
16¾"	-	64¼"	36⅞"	29⅞"	7.5 yds.	116.0'	121 lbs.	68.33'/1
425 mm	-	1632 mm	918 mm	740 mm	6.9 m	10.8 sqm	54.9 kg	1.93 cu.

COM	COL	1	2	3	4	5	6	7	8	9	10	11
3130	3280	3830	3947	4014	4147	4264	4314	4397	4514	4614	4730	5397

item 5905

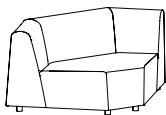

**Corner module
Fully upholstered**

All necessary ganging brackets are included and pre-installed

Specify fabric railroaded when used with item 5905 corner module.

SCS Indoor Advantage™ Gold and LEVEL® 2 certified. See terms and conditions for additional environmental information.

Seat Height	Arm Height	W	D	H	Fabric	Leather	Weight	Cubes/Qty
16¾"	-	47¼"	47¼"	29⅞"	7.5 yds.	120.0'	195 lbs.	100.22'/1
425 mm	-	1200 mm	1200 mm	740 mm	6.9 m	11.1 sqm	88.0 kg	2.84 cu.

COM	COL	1	2	3	4	5	6	7	8	9	10	11
3130	3280	3830	3947	4014	4147	4264	4314	4397	4514	4614	4730	5397

item 5901CH



**Center high module
Fully upholstered**

All necessary ganging brackets are included and pre-installed

Specify fabric railroaded when used with item 5905 corner module.

SCS Indoor Advantage™ Gold and LEVEL® 2 certified. See terms and conditions for additional environmental information.

Seat Height	Arm Height	W	D	H	Fabric	Leather	Weight	Cubes/Qty
16¾"	-	38"	37¼"	31⅞"	5.0 yds.	88.0'	85 lbs.	32.10'/1
425 mm	-	965 mm	946 mm	740 mm	4.6 m	8.2 sqm	38.5 kg	32.10'/1

COM	COL	1	2	3	4	5	6	7	8	9	10	11
2157	2257	2624	2702	2746	2835	2913	2946	3002	3080	3146	3224	3669

item5903LW

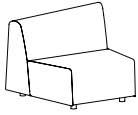

**Low left - high right wedge module
Fully upholstered**

All necessary ganging brackets are included and pre-installed

Specify fabric railroaded when used with item 5905 corner module.

SCS Indoor Advantage™ Gold and LEVEL® 2 certified. See terms and conditions for additional environmental information.

Seat Height	Arm Height	W	D	H	Fabric	Leather	Weight	Cubes/Qty
16¾"	-	38"	37¼"	31½"	4.7 yds.	87.0'	85 lbs.	32.10'/1
425 mm	-	965 mm	946 mm	740 mm	4.3 sqm	8.1 sqm	38.5 kg	.91 cu.

COM	COL	1	2	3	4	5	6	7	8	9	10	11
2157	2251	2596	2669	2711	2795	2868	2899	2951	3024	3087	3160	3578

item 5903RW

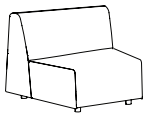

**Low right - high left wedge module
Fully upholstered**

All necessary ganging brackets are included and pre-installed

Specify fabric railroaded when used with item 5905 corner module.

SCS Indoor Advantage™ Gold and LEVEL® 2 certified. See terms and conditions for additional environmental information.

Seat Height	Arm Height	W	D	H	Fabric	Leather	Weight	Cubes/Qty
16¾"	-	38"	36¾"	31½"	4.7 yds.	87.0'	85 lbs.	32.10'/1
425 mm	-	965 mm	930 mm	740 mm	4.3 sqm	8.1 sqm	38.5 kg	.91 cu.

COM	COL	1	2	3	4	5	6	7	8	9	10	11
2157	2251	2596	2669	2711	2795	2868	2899	2951	3024	3087	3160	3578

Luca Seating System Specification Guide

Standard Features



Luca is a modular seating system comprised of 41 unique modules which can be used as freestanding or interchangeably to create an unlimited number of configurations. Options include freestanding benches, two-seat and three-seat modules, corner modules and seating and bench modules with end tables. End table tops are available in oak or walnut and are offered with and without power. Legs are available in one of three finishes: polished aluminum, matte black powder coat and satin white powder coat.

Luca is fully upholstered with 5/8" diameter non-marring adjustable nylon glides. When ordering configurations, please provide the total COM yardage from the same dye lot in a continuous roll(s). All COM/COL fabrics must be preapproved by Bernhardt Design prior to application. SCS Indoor Advantage™ Gold and LEVEL® 2 certified. See terms and conditions for additional finish and environmental information.corporate office for specification assistance.

Configurations are connected by a ganging bracket. Ganging brackets are sold separately and will ship with product. See the Luca lounge-modular accessories page for ordering information.

Please visit BernhardtDesign.com for a complete library of 2D, 3D and Revit models. You may also contact your local sales representative or the Bernhardt Design corporate office for specification assistance.

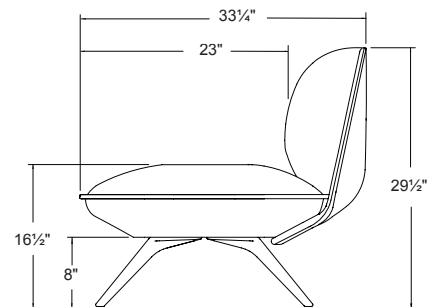

Side View of Armless Sofa

5/8" Non-marring Adjustable Nylon Glides

Leg Options

Polished Aluminum - 6



Matte Black Powder Coat- 3



Satin White Powder Coat- W

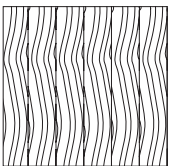

Table Options



Veneer Selection

OAK Oak
Order Code - C
Rift Cut



WLT Walnut
Order Code - 9
Flat Cut

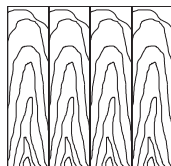

A three-character sku identifies each wood veneer option as well as standard finishes. Base and top finishes are specified separately. When selecting light finishes such as 836, 837, 840, or 870, the color and characteristic variances of the wood veneer are apparent, and exact color matches are not possible.

OAK Oak

Standard Finish		
871	860	870
837	836	861
865	805	866
872	839	845

WLT Walnut

Standard Finish	
872	861
860	823
839	866
870	

Standard Finish		
M73	M71	M75
M74	M76	M77

Edge Profile

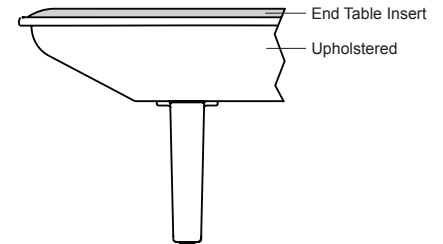

Surface Mount Power Modules

Luca offers a proprietary surface mount power solution which is installed flush to the worksurface and provides (2) 15 amp receptacles and (1) 2 amp USB-A port and (1) 2 amp USB-C port. The unit has a 10' infeed with a grounded plug. Power module finish is determined by leg finish selection.



Power Module
Black Finish

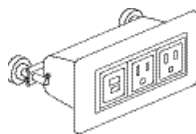

- (2) 120 v 60 Hz. 15 amp receptacles
- (1) 2 amp USB-A port, 10 watt
- (1) 2 amp USB-C port, 20 watt
- 6½" w x 3" d x 2¾" h

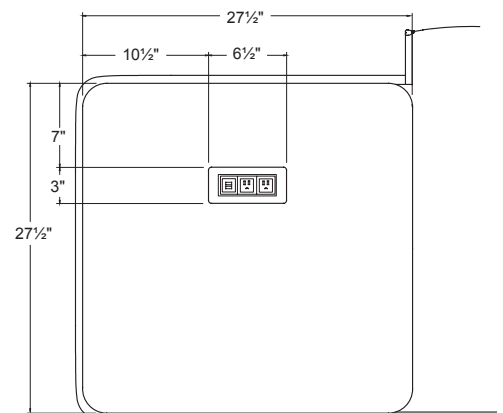

Connecting Modules



Luca modules connect by attaching a ganging bracket to the underside of the furniture. Order one ganging bracket per point of connection of modular units. Ganging brackets are sold separately and will ship with product.

To connect the modules together insert the three fasteners into the inserts at the location each module is desired to be connected. Push modules together in desired location.

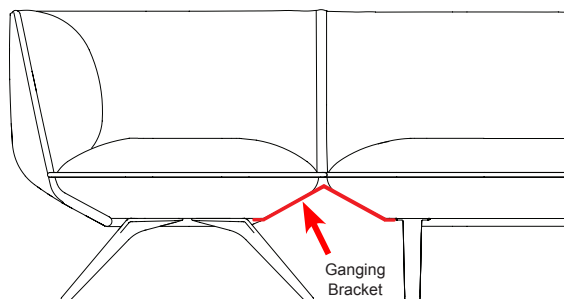

Ganging bracket is concealed behind flange and is not visible when looking at the sofa.

Leave 1/4" between head of fastener and upholstery. Fit bracket over heads of fasteners and slide bracket to lock fasteners into keyhole slots cut into fastener. Tighten fasteners against bracket.

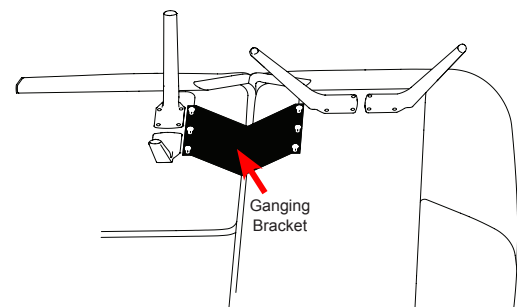

Under side view of the ganging bracket placement

Luca Seating System Sample Configurations

1	Sku	Description
	8P16R	Two-seat. Right Arm Facing Armless Module with End Table. Power
	8D27N	Three-Seat Module
2	8D05N	Two-seat Bench (Refer to Seating - Benches)
	8D47R	Three-seat. Right Arm Facing Armless Open Module
	8D57L	Three-seat. Left Arm Facing Open Module
	8D15N	Two-seat. Armless Module
3	8D37L	Three-seat. Left Arm Facing Module
	8D37L	Three-seat. Left Arm Facing Module
	8D37R	Three-seat. Right Arm Facing Module
	8D37R	Three-seat. Right Arm Facing Module
4	8D35L	Two-seat. Left Arm Facing Module
	8D31N	Inside 45° Corner Module. Armless
	8D35R	Two-seat. Right Arm Facing Module

Luca Seating System Sample Configurations

5

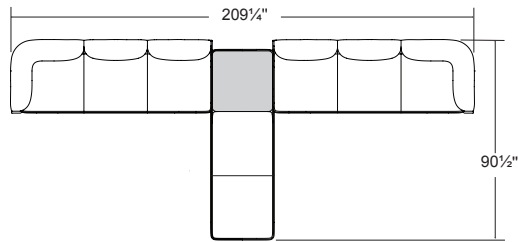
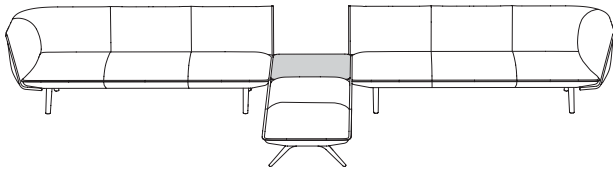

Sku **Description**

- 8D37L** Three-seat. Left Arm Facing Module
- 8D06N** Two-seat Bench with End Table (Refer to Seating - Benches)
- 8D37R** Three-seat. Right Arm Facing Module

6

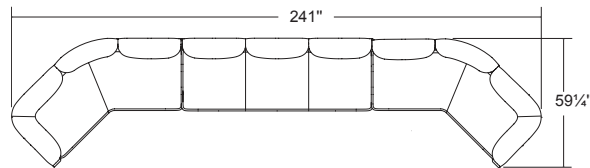
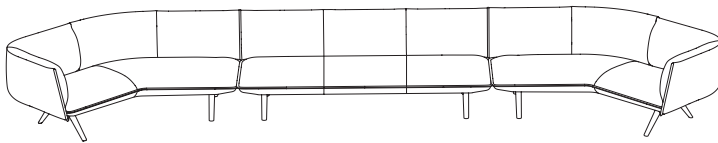

- 8D33L** Inside 45° Corner Module. Left Arm Facing
- 8D17N** Three-seat Armless Module
- 8D33R** Inside 45° Corner Module. Right Arm Facing

7

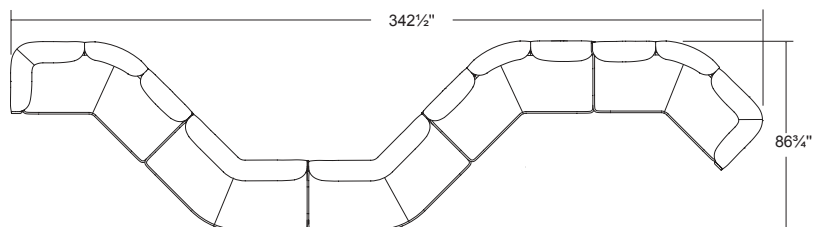
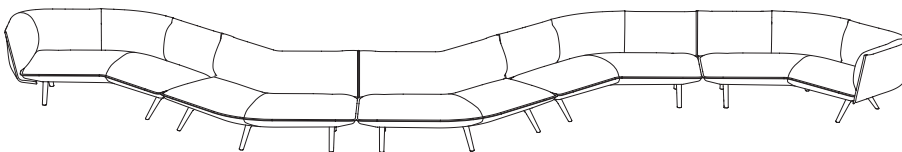

- 8D33L** Inside 45° Corner Module. Left Arm Facing
- 8D32N** Outside 45° Corner Module. Armless
- 8D32N** Outside 45° Corner Module. Armless
- 8D31N** Inside 45° Corner Module. Armless
- 8D33R** Inside 45° Corner Module. Right Arm Facing

luca 8D25N

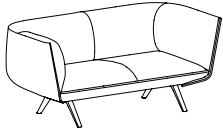

Loveseat
Polished aluminum or powder coat legs
Upholstered

When using a combination of fabrics or leathers, specify the application by designating the appropriate letter, shown below, on the purchase order. Yardage shown must be used.

See terms and conditions for contrasting upholstery upcharges.

- A) One fabric or leather for seat
yardage: 4.5 yds. leather: 73.0 sq. ft.
- B) One fabric or leather for inside back, outside back, outer shell and inside arms
yardage: 7.5 yds. leather: 122.0 sq. ft.

SCS Indoor Advantage™ Gold and LEVEL® 2 certified. See terms and conditions for instructions for additional environmental information.

Seat Height	Arm Height	W	D	H	Fabric	Leather	Weight	Cubes/Qty
16½"	29 ½"	66½"	33 ¼"	29½"	12.0 yds.	195.0'	165 lbs.	52.25'/1
419 mm	749 mm	1689 mm	845 mm	749 mm	11 m	18.1 sqm	74.9 kg	1.50 cu.

COM	COL	1	2	3	4	5	6	7	8	9	10	11
4866	5106	5986	6173	6280	6493	6680	6760	6893	7080	7240	7426	8493

luca 8D27N

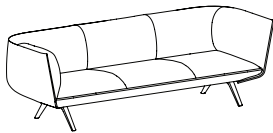

Sofa
Polished aluminum or powder coat legs
Upholstered

When using a combination of fabrics or leathers, specify the application by designating the appropriate letter, shown below, on the purchase order. Yardage shown must be used.

See terms and conditions for contrasting upholstery upcharges.

- A) One fabric or leather for seat
yardage: 6.75 yds. leather: 110.0 sq. ft.
- B) One fabric or leather for inside back, outside back, outer shell and inside arms.
yardage: 10.0 yds. leather: 165.0 sq. ft.

SCS Indoor Advantage™ Gold and LEVEL® 2 certified. See terms and conditions for additional environmental information.

Seat Height	Arm Height	W	D	H	Fabric	Leather	Weight	Cubes/Qty
16½"	29½"	95½"	33¼"	29½"	16.75 yds.	275.0'	216 lbs.	71.85'/1
419 mm	749 mm	2432 mm	845 mm	749 mm	15.32 m	25.5 sqm	98.2 kg	2.03 cu.

COM	COL	1	2	3	4	5	6	7	8	9	10	11
5979	6314	7543	7803	7952	8250	8511	8622	8808	9069	9292	9553	11042

sku

frame finish

--	--	--	--	--	--	--	--	--	--	--	--	--

- 6** polished aluminum standard, OR
specify powder coat, upcharge \$200
- 3** matte black powder coat
- W** satin white powder coat

luca 8D25N

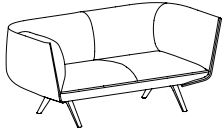

Two-seat module
Use for making 90° corner configurations
Polished aluminum or powder coat legs
Upholstered

Ganging brackets are sold separately and will ship with the product. See Luca accessories page to order brackets.

When using a combination of fabrics or leathers, specify the application by designating the appropriate letter, shown below, on the purchase order. Yardage shown must be used.

See terms and conditions for contrasting upholstery upcharges.

- A) One fabric or leather for seat
 yardage: 4.5 yds. leather: 73.0 sq. ft.
- B) One fabric or leather for inside back, outside back, outer shell and inside arms
 yardage: 9.0 yds. leather: 146.0 sq. ft.

SCS Indoor Advantage™ Gold and LEVEL® 2 certified. See terms and conditions for additional environmental information.

Seat Height	Arm Height	W	D	H	Fabric	Leather	Weight	Cubes/Qty
16½"	29 ½"	66½"	33 ¼"	29½"	12.0 yds.	195.0'	165 lbs.	52.25/1
419 mm	749 mm	1689 mm	845 mm	749 mm	11 m	18.1 sqm	74.9 kg	1.50 cu.

COM	COL	1	2	3	4	5	6	7	8	9	10	11
4866	5106	5986	6173	6280	6493	6680	6760	6893	7080	7240	7426	8493

luca 8D35L

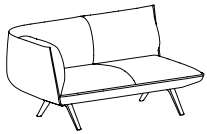

Two-seat module
Left arm facing
Polished aluminum or powder coat legs
Upholstered

Ganging brackets are sold separately and will ship with the product. See Luca accessories page to order brackets.

When using a combination of fabrics or leathers, specify the application by designating the appropriate letter, shown below, on the purchase order. Yardage shown must be used.

See terms and conditions for contrasting upholstery upcharges.

- A) One fabric or leather for seat
 yardage: 5.0 yds. leather: 81.0 sq. ft.
- B) One fabric or leather for inside back, outside back, outer shell and inside arm
 yardage: 7.0 yds. leather: 114.0 sq. ft.

SCS Indoor Advantage™ Gold and LEVEL® 2 certified. See terms and conditions for additional environmental information.

Seat Height	Arm Height	W	D	H	Fabric	Leather	Weight	Cubes/Qty
16½"	29½"	62¾"	33¼"	29½"	11.0 yds.	180.0'	151 lbs.	52.25/1
419 mm	749 mm	1594 mm	845 mm	749 mm	10.1 m	16.7 sqm	68.5 kg	1.50 cu.

COM	COL	1	2	3	4	5	6	7	8	9	10	11
4311	4531	5338	5509	5607	5803	5974	6047	6169	6340	6487	6658	7636

sku

frame finish

--	--	--	--	--	--	--	--	--	--	--	--	--

- 6** polished aluminum standard, OR
- specify powder coat, upcharge \$200
- 3** matte black powder coat
- W** satin white powder coat

luca 8D35R

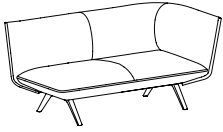

Two-seat module
Right arm facing
Polished aluminum or powder coat legs
Upholstered

Ganging brackets are sold separately and will ship with the product. See Luca accessories page to order brackets.

When using a combination of fabrics or leathers, specify the application by designating the appropriate letter, shown below, on the purchase order. Yardage shown must be used.

See terms and conditions for contrasting upholstery upcharges.

- A) One fabric or leather for seat
yardage: 5.0 yds. leather: 81.0 sq. ft.
- B) One fabric or leather for inside back, outside back, outer shell and inside arm
yardage: 7.0 yds. leather: 114.0 sq. ft.

SCS Indoor Advantage™ Gold and LEVEL® 2 certified. See terms and conditions for additional environmental information.

Seat Height	Arm Height	W	D	H	Fabric	Leather	Weight	Cubes/Qty
16½"	29½"	62¾"	33¼"	29½"	11.0 yds.	180.0'	151 lbs.	52.25/1
419 mm	749 mm	1594 mm	845 mm	749 mm	10.1 m	16.7 sqm	68.5 kg	1.50 cu.

COM	COL	1	2	3	4	5	6	7	8	9	10	11
4311	4531	5338	5509	5607	5803	5974	6047	6169	6340	6487	6658	7636

luca 8D15N

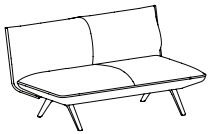

Two-seat armless module
Polished aluminum or powder coat legs
Upholstered

Ganging brackets are sold separately and will ship with the product. See Luca accessories page to order brackets.

When using a combination of fabrics or leathers, specify the application by designating the appropriate letter, shown below, on the purchase order. Yardage shown must be used.

See terms and conditions for contrasting upholstery upcharges.

- A) One fabric or leather for seat
yardage: 4.5 yds. leather: 73.0 sq. ft.
- B) One fabric or leather for inside back and outside back
yardage: 4.5 yds. leather: 73.0 sq. ft.

SCS Indoor Advantage™ Gold and LEVEL® 2 certified. See terms and conditions for additional environmental information.

Seat Height	Arm Height	W	D	H	Fabric	Leather	Weight	Cubes/Qty
16½"	-	58½"	33¼"	29½"	9.5 yds.	160.0'	128 lbs.	52.25/1
419 mm	-	1486 mm	845 mm	749 mm	8.7 m	14.7 sqm	58.1 kg	1.50 cu.

COM	COL	1	2	3	4	5	6	7	8	9	10	11
3616	3806	4503	4651	4735	4904	5052	5115	5221	5369	5495	5643	6488

sku

frame finish

--	--	--	--	--	--	--	--	--	--	--	--	--

- 6** polished aluminum standard, OR
- specify powder coat, upcharge \$200
- 3** matte black powder coat
- W** satin white powder coat

luca 8D55L

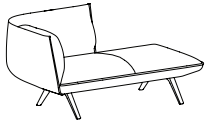

Two-seat open module
Left arm facing
Polished aluminum or powder coat legs
Upholstered

Ganging brackets are sold separately and will ship with the product. See Luca accessories page to order brackets.

When using a combination of fabrics or leathers, specify the application by designating the appropriate letter, shown below, on the purchase order. Yardage shown must be used.

See terms and conditions for contrasting upholstery upcharges.

- A) One fabric or leather for seat
yardage: 5.0 yds. leather: 81.0 sq. ft.
- B) One fabric or leather for insided back, outside back, outer shell and inside arm
yardage: 5.25 yds. leather: 85.0 sq. ft.

SCS Indoor Advantage™ Gold and LEVEL® 2 certified. See terms and conditions for additional environmental information.

Seat Height	Arm Height	W	D	H	Fabric	Leather	Weight	Cubes/Qty
16½"	29½"	62¾"	33¼"	29½"	9.0 yds.	150.0'	135 lbs.	52.25/1
419 mm	749 mm	1594 mm	845 mm	749 mm	8.2 m	13.9 sqm	61.2 kg	1.50 cu.

COM	COL	1	2	3	4	5	6	7	8	9	10	11
3893	4073	4733	4873	4953	5113	5253	5313	5413	5553	5673	5813	6613

luca 8D55R

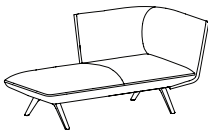

Two-seat open module
Right arm facing
Polished aluminum or powder coat legs
Upholstered

Ganging brackets are sold separately and will ship with the product. See Luca accessories page to order brackets.

When using a combination of fabrics or leathers, specify the application by designating the appropriate letter, shown below, on the purchase order. Yardage shown must be used.

See terms and conditions for contrasting upholstery upcharges.

- A) One fabric or leather for seat
yardage: 5.0 yds. leather: 81.0 sq. ft.
- B) One fabric or leather for inside back, outside back, outer shell and inside arm
yardage: 5.25 yds. leather: 85.0 sq. ft.

SCS Indoor Advantage™ Gold and LEVEL® 2 certified. See terms and conditions for additional environmental information.

Seat Height	Arm Height	W	D	H	Fabric	Leather	Weight	Cubes/Qty
16½"	29½"	62¾"	33¼"	29½"	9.0 yds.	150.0'	135 lbs.	52.25/1
419 mm	749 mm	1594 mm	845 mm	749 mm	8.2 m	13.9 sqm	61.2 kg	1.50 cu.

COM	COL	1	2	3	4	5	6	7	8	9	10	11
3893	4073	4733	4873	4953	5113	5253	5313	5413	5553	5673	5813	6613

sku

frame finish

--	--	--	--	--	--	--	--	--	--	--	--	--

- 6** polished aluminum standard, OR
- specify powder coat, upcharge \$200
- 3** matte black powder coat
- W** satin white powder coat

luca 8D45L

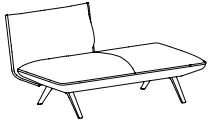

Two-seat armless open module
Left side facing
Polished aluminum or powder coat legs
Upholstered

Ganging brackets are sold separately and will ship with the product. See Luca accessories page to order brackets.

When using a combination of fabrics or leathers, specify the application by designating the appropriate letter, shown below, on the purchase order. Yardage shown must be used.

See terms and conditions for contrasting upholstery upcharges.

- A) One fabric or leather for seat
 yardage: 5.25 yds. leather: 85.0 sq. ft.
- B) One fabric or leather for inside back and outside back
 yardage: 3.0 yds. leather: 50.0 sq. ft.

SCS Indoor Advantage™ Gold and LEVEL® 2 certified. See terms and conditions for additional environmental information.

Seat Height	Arm Height	W	D	H	Fabric	Leather	Weight	Cubes/Qty
16½"	-	58½"	33¼"	29½"	7.5 yds.	125.0'	112 lbs.	52.25/1
419 mm	-	1486 mm	845 mm	749 mm	6.9 m	11.6 sqm	50.9 kg	1.50 cu.

COM	COL	1	2	3	4	5	6	7	8	9	10	11
3198	3348	3898	4015	4082	4215	4332	4382	4465	4582	4682	4798	5465

luca 8D45R

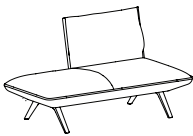

Two-seat armless open module
Right side facing
Polished aluminum or powder coat legs
Upholstered

Ganging brackets are sold separately and will ship with the product. See Luca accessories page to order brackets.

When using a combination of fabrics or leathers, specify the application by designating the appropriate letter, shown below, on the purchase order. Yardage shown must be used.

See terms and conditions for contrasting upholstery upcharges.

- A) One fabric or leather for seat
 yardage: 5.25 yds. leather: 85.0 sq. ft.
- B) One fabric or leather for inside back and outside back
 yardage: 3.0 yds. leather: 50.0 sq. ft.

SCS Indoor Advantage™ Gold and LEVEL® 2 certified. See terms and conditions for additional environmental information.

Seat Height	Arm Height	W	D	H	Fabric	Leather	Weight	Cubes/Qty
16½"	-	58½"	33¼"	29½"	7.5 yds.	125.0'	112 lbs.	52.25/1
419 mm	-	1486 mm	845 mm	749 mm	6.9 m	11.6 sqm	50.9 kg	1.50 cu.

COM	COL	1	2	3	4	5	6	7	8	9	10	11
3198	3348	3898	4015	4082	4215	4332	4382	4465	4582	4682	4798	5465

sku

frame finish

--	--	--	--	--	--	--	--	--	--	--	--	--

- 6** polished aluminum standard, OR
 specify powder coat, upcharge \$200
- 3** matte black powder coat
- W** satin white powder coat

luca 8D27N

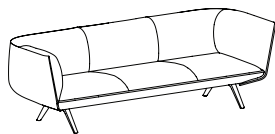

Three-seat module
Use for making 90° corner configurations
Polished aluminum or powder coat legs
Upholstered

Ganging brackets are sold separately and will ship with the product. See Luca accessories page to order brackets.

When using a combination of fabrics or leathers, specify the application by designating the appropriate letter, shown below, on the purchase order. Yardage shown must be used.

See terms and conditions for contrasting upholstery upcharges.

- A) One fabric or leather for seat
 yardage: 6.75 yds. leather: 110.0 sq. ft.
- B) One fabric or leather for inside back, outside back, outer shell and inside arms
 yardage: 11.25 yds. leather: 183.0 sq. ft.

SCS Indoor Advantage™ Gold and LEVEL® 2 certified. See terms and conditions for additional environmental information.

Seat Height	Arm Height	W	D	H	Fabric	Leather	Weight	Cubes/Qty
16½"	29½"	95¾"	33¼"	29½"	16.75 yds.	275.0'	216 lbs.	71.85/1
419 mm	749 mm	2432 mm	845 mm	749 mm	15.32 m	25.5 sqm	98.2 kg	2.03 cu.

COM	COL	1	2	3	4	5	6	7	8	9	10	11
5979	6314	7543	7803	7952	8250	8511	8622	8808	9069	9292	9553	11042

luca 8D37L

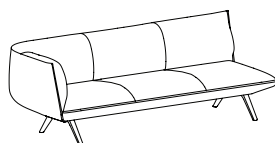

Three-seat module
Left arm facing
Polished aluminum or powder coat legs
Upholstered

Ganging brackets are sold separately and will ship with the product. See Luca accessories page to order brackets. ts.

When using a combination of fabrics or leathers, specify the application by designating the appropriate letter, shown below, on the purchase order. Yardage shown must be used.

See terms and conditions for contrasting upholstery upcharges.

- A) One fabric or leather for seat
 yardage: 7.0 yds. leather: 114.0 sq. ft.
- B) One fabric or leather for inside back, outside back, outer shell and inside arm
 yardage: 9.5 yds. leather: 154.0 sq. ft.

SCS Indoor Advantage™ Gold and LEVEL® 2 certified. See terms and conditions for additional environmental information.

Seat Height	Arm Height	W	D	H	Fabric	Leather	Weight	Cubes/Qty
16½"	29½"	91¼"	33¼"	29½"	13.25 yds.	215.0'	202 lbs.	71.85/1
419 mm	749 mm	2318 mm	845 mm	749 mm	12.1 m	20.0 sqm	91.6 kg	2.03 cu.

COM	COL	1	2	3	4	5	6	7	8	9	10	11
5422	5687	6659	6865	6983	7219	7425	7513	7660	7866	8043	8249	9427

sku

frame finish

--	--	--	--	--	--	--	--	--	--	--	--	--

- 6** polished aluminum standard, OR
- specify powder coat, upcharge \$200
- 3** matte black powder coat
- W** satin white powder coat

luca 8D37R

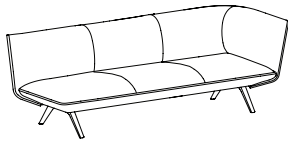

Three-seat module
Right arm facing
Polished aluminum or powder coat legs
Upholstered

Ganging brackets are sold separately and will ship with the product. See Luca accessories page to order brackets.

When using a combination of fabrics or leathers, specify the application by designating the appropriate letter, shown below, on the purchase order. Yardage shown must be used.

See terms and conditions for contrasting upholstery upcharges.

- A) One fabric or leather for seat
yardage: 7.0 yds. leather: 114.0 sq. ft.
- B) One fabric or leather for inside back, outside back, outer shell and inside arms
yardage: 9.5 yds. leather: 154.0 sq. ft.

SCS Indoor Advantage™ Gold and LEVEL® 1 certified. See terms and conditions for additional environmental information.

Seat Height	Arm Height	W	D	H	Fabric	Leather	Weight	Cubes/Qty
16½"	29½"	91¼"	33¼"	29½"	13.25 yds.	215.0'	202 lbs.	71.85/1
419 mm	749 mm	2318 mm	845 mm	749 mm	12.1 m	20.0 sqm	91.6 kg	2.03 cu.

COM	COL	1	2	3	4	5	6	7	8	9	10	11
5422	5687	6659	6865	6983	7219	7425	7513	7660	7866	8043	8249	9427

luca 8D17N

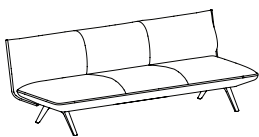

Three-seat module
Armless
Polished aluminum or powder coat legs
Upholstered

When using a combination of fabrics or leathers, specify the application by designating the appropriate letter, shown below, on the purchase order. Yardage shown must be used.

See terms and conditions for contrasting upholstery upcharges.

- A) One fabric or leather for seat
yardage: 7.5 yds. leather: 122.0 sq. ft.
- B) One fabric or leather for inside back and outside back
yardage: 7.5 yds. leather: 122.0 sq. ft.

SCS Indoor Advantage™ Gold and LEVEL® 1 certified. See terms and conditions for additional environmental information.

Seat Height	Arm Height	W	D	H	Fabric	Leather	Weight	Cubes/Qty
16½"	-	87¼"	33 ¼"	29 ½"	12.5 yds.	203.0'	181 lbs.	71.85/1
419 mm	-	2216 mm	845 mm	749 mm	11.3 m	18.9 sqm	82.1 kg	2.03 cu.

COM	COL	1	2	3	4	5	6	7	8	9	10	11
4728	4978	5895	6090	6201	6423	6617	6701	6840	7034	7201	7395	8506

sku

frame finish

--	--	--	--	--	--	--	--	--	--	--	--	--

- 6** polished aluminum standard, OR
specify powder coat, upcharge \$200
- 3** matte black powder coat
- W** satin white powder coat

luca 8D57L

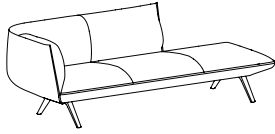

Three-seat open module
Left arm facing
Polished aluminum or powder coat legs
Upholstered

Ganging brackets are sold separately and will ship with the product. See Luca accessories page to order brackets.

When using a combination of fabrics or leathers, specify the application by designating the appropriate letter, shown below, on the purchase order. Yardage shown must be used.

See terms and conditions for contrasting upholstery upcharges.

- A) One fabric or leather for seat
yardage: 7.0 yds. leather: 114.0 sq. ft.
- B) One fabric or leather for inside back, outside back, outer shell and inside arms
yardage: 7.5 yds. leather: 122.0 sq. ft.

SCS Indoor Advantage™ Gold and LEVEL® 2 certified. See terms and conditions for additional environmental information.

Seat Height	Arm Height	W	D	H	Fabric	Leather	Weight	Cubes/Qty
16½"	29½"	91¼"	33¼"	29½"	11.75 yds.	190.0'	190 lbs.	71.85/1
419 mm	749 mm	2318 mm	845 mm	749 mm	10.7 m	17.7 sqm	86.2 kg	2.03 cu.

COM	COL	1	2	3	4	5	6	7	8	9	10	11
5006	5241	6103	6286	6390	6599	6782	6860	6991	7174	7330	7513	8558

luca 8D57R

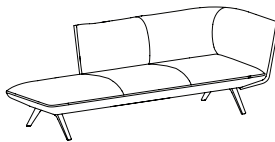

Three-seat open module
Right arm facing
Polished aluminum or powder coat legs
Upholstered

Ganging brackets are sold separately and will ship with the product. See Luca accessories page to order brackets.

When using a combination of fabrics or leathers, specify the application by designating the appropriate letter, shown below, on the purchase order. Yardage shown must be used.

See terms and conditions for contrasting upholstery upcharges.

- A) One fabric or leather for seat
yardage: 7.0 yds. leather: 114.0 sq. ft.
- B) One fabric or leather for inside back, outside back, outer shell and inside arms
yardage: 7.5 yds. leather: 122.0 sq. ft.

SCS Indoor Advantage™ Gold and LEVEL® 2 certified. See terms and conditions for additional environmental information.

Seat Height	Arm Height	W	D	H	Fabric	Leather	Weight	Cubes/Qty
16½"	29½"	91¼"	33¼"	29½"	11.75 yds.	190.0'	190 lbs.	71.85/1
419 mm	749 mm	2318 mm	845 mm	749 mm	10.7 m	17.7 sqm	86.2 kg	2.03 cu.

COM	COL	1	2	3	4	5	6	7	8	9	10	11
5006	5241	6103	6286	6390	6599	6782	6860	6991	7174	7330	7513	8558

sku

frame finish

--	--	--	--	--	--	--	--	--	--	--	--	--

- 6** polished aluminum standard, OR
- specify powder coat, upcharge \$200
- 3** matte black powder coat
- W** satin white powder coat

luca 8D47L

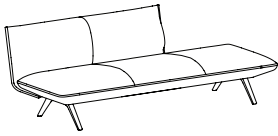

Three-seat armless open module
Left side facing
Polished aluminum or powder coat legs
Upholstered

Ganging brackets are sold separately and will ship with the product. See Luca accessories page to order brackets.

When using a combination of fabrics or leathers, specify the application by designating the appropriate letter, shown below, on the purchase order. Yardage shown must be used.

See terms and conditions for contrasting upholstery upcharges.

- A) One fabric or leather for seat
 yardage: 7.5 yds. leather: 122.0 sq. ft.
- B) One fabric or leather for inside back and outside back
 yardage: 5.25 yds. leather: 85.0 sq. ft.

SCS Indoor Advantage™ Gold and LEVEL® 1 certified. See terms and conditions for additional environmental information.

Seat Height	Arm Height	W	D	H	Fabric	Leather	Weight	Cubes/Qty
16½"	-	87¼"	33¼"	29½"	10.75 yds.	175.0'	165 lbs.	71.85/1
419 mm	-	2216 mm	845 mm	749 mm	9.8 m	16.3 sqm	74.8 kg	2.03 cu.

COM	COL	1	2	3	4	5	6	7	8	9	10	11
4311	4526	5315	5482	5578	5769	5936	6008	6127	6294	6438	6605	7560

luca 8D47R

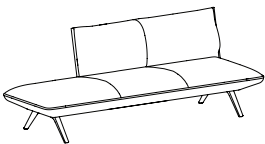

Three-seat armless open module
Right side facing
Polished aluminum or powder coat legs
Upholstered

Ganging brackets are sold separately and will ship with the product. See Luca accessories page to order brackets.

When using a combination of fabrics or leathers, specify the application by designating the appropriate letter, shown below, on the purchase order. Yardage shown must be used.

See terms and conditions for contrasting upholstery upcharges.

- A) One fabric or leather for seat
 yardage: 7.5 yds. leather: 122.0 sq. ft.
- B) One fabric or leather for inside back and outside back
 yardage: 5.25 yds. leather: 85.0 sq. ft.

SCS Indoor Advantage™ Gold and LEVEL® 1 certified. See terms and conditions for additional environmental information.

Seat Height	Arm Height	W	D	H	Fabric	Leather	Weight	Cubes/Qty
16½"	-	87¼"	33¼"	29½"	10.75 yds.	175.0'	165 lbs.	71.85/1
419 mm	-	2216 mm	845 mm	749 mm	9.8 m	16.3 sqm	74.8 kg	2.03 cu.

COM	COL	1	2	3	4	5	6	7	8	9	10	11
4311	4526	5315	5482	5578	5769	5936	6008	6127	6294	6438	6605	7560

sku

frame finish

--	--	--	--	--	--	--	--	--	--	--	--	--

- 6** polished aluminum standard, OR
- specify powder coat, upcharge \$200
- 3** matte black powder coat
- W** satin white powder coat

luca 8D26L

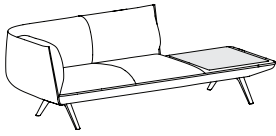

Two-seat module with end table
Left arm facing
Polished aluminum or powder coat legs
Upholstered

End table available in all oak and walnut finishes. When specifying light finish the natural characteristics of the wood will be visible and color will vary.

Ganging brackets are sold separately and will ship with the product. See Luca accessories page to order brackets.

When using a combination of fabrics or leathers, specify the application by designating the appropriate letter, shown below, on the purchase order. Yardage shown must be used.

See terms and conditions for contrasting upholstery upcharges.

- A) One fabric or leather for seat
 yardage: 6.5 yds. leather: 105.0 sq. ft.
- B) One fabric or leather for inside back, outside back, outer shell and inside arm
 yardage: 5.0 yds. leather: 82.0 sq. ft.

SCS Indoor Advantage™ Gold and LEVEL® 2 certified. See terms and conditions for additional finish and environmental information.

Seat Height	Arm Height	W	D	H	Fabric	Leather	Weight	Cubes/Qty
16½"	29½"	90¼"	33¼"	29½"	11.5 yds.	190.0'	209 lbs.	71.85'/1
419 mm	749 mm	2286 mm	845 mm	749 mm	10.5 m	17.7 sqm	94.8 kg	2.03 cu.

COM	COL	1	2	3	4	5	6	7	8	9	10	11
5561	5791	6635	6814	6916	7120	7299	7376	7504	7683	7836	8015	9037

sku	frame finish	run-off top species	wood top finish
	6 polished aluminum standard, OR specify powder coat, upcharge \$200 3 matte black powder coat W satin white powder coat	C oak 9 walnut	see seating finishes

luca 8P26L

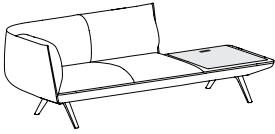

Power
Two-seat module with end table
Left side facing
Polished aluminum or powder coat legs
Upholstered

End table available in all oak and walnut finishes. When specifying light finish the natural characteristics of the wood will be visible and color will vary.

Ganging brackets are sold separately and will ship with the product. See Luca accessories page to order brackets.

Power: Surface mount power provides (2) 15 amp receptables, (1) 2 amp USB-A port, 10 watt and (1) 2 amp USB-C port, 20 watt.

When using a combination of fabrics or leathers, specify the application by designating the appropriate letter, shown below, on the purchase order. Yardage shown must be used.

See terms and conditions for contrasting upholstery upcharges.

- A) One fabric or leather for seat
 yardage: 6.5 yds. leather: 105.0 sq. ft.
- B) One fabric or leather for inside back, outside back, outer shell and inside arms
 yardage: 5.0 yds. leather: 82.0 sq. ft.

SCS Indoor Advantage™ Gold and LEVEL® 2 certified. See terms and conditions for additional finish and environmental information.

Seat Height	Arm Height	W	D	H	Fabric	Leather	Weight	Cubes/Qty
16½"	29½"	90¼"	33¼"	29½"	11.5 yds.	190.0'	212 lbs.	71.85/1
419 mm	749 mm	2286 mm	845 mm	749 mm	10.5 m	17.7 sqm	96.2 kg	2.03 cu.

COM	COL	1	2	3	4	5	6	7	8	9	10	11
6326	6556	7400	7579	7681	7885	8064	8141	8269	8448	8601	8780	9802

sku	frame finish	run-off top species	wood top finish
	6 polished aluminum standard, OR specify powder coat, upcharge \$200 3 matte black powder coat W satin white powder coat	C oak 9 walnut	see seating finishes

luca 8D26R

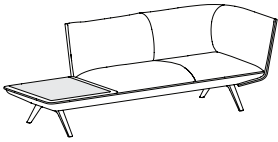

Two-seat module with end table
Right arm facing
Polished aluminum or powder coat legs
Upholstered

End table available in all oak and walnut finishes. When specifying light finish the natural characteristics of the wood will be visible and color will vary.

Ganging brackets are sold separately and will ship with the product. See Luca accessories page to order brackets.

When using a combination of fabrics or leathers, specify the application by designating the appropriate letter, shown below, on the purchase order. Yardage shown must be used.

See terms and conditions for contrasting upholstery upcharges.

- A) One fabric or leather for seat
 yardage: 6.5 yds. leather: 105.0 sq. ft.
- B) One fabric or leather for inside back, outside back, outer shell and inside arm
 yardage: 5.0 yds. leather: 82.0 sq. ft.

SCS Indoor Advantage™ Gold and LEVEL® 2 certified. See terms and conditions for additional finish and environmental information.

Seat Height	Arm Height	W	D	H	Fabric	Leather	Weight	Cubes/Qty
16½"	29½"	90¼"	33¼"	29½"	11.5 yds.	190.0'	209 lbs.	71.85'/1
419 mm	749 mm	2286 mm	845 mm	749 mm	10.5 m	17.7 sqm	94.8 kg	2.03 cu.

COM	COL	1	2	3	4	5	6	7	8	9	10	11
5561	5791	6635	6814	6916	7120	7299	7376	7504	7683	7836	8015	9037

sku	frame finish	run-off top species	wood top finish
	6 polished aluminum standard, OR specify powder coat, upcharge \$200 3 matte black powder coat W satin white powder coat	C oak 9 walnut	see seating finishes

luca 8P26R

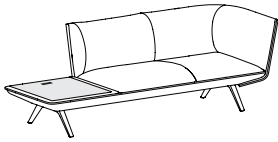

Power
Two-seat module with end table
Right side facing
Polished aluminum or powder coat legs
Upholstered

End table available in all oak and walnut finishes. When specifying light finish the natural characteristics of the wood will be visible and color will vary.

Ganging brackets are sold separately and will ship with the product. See Luca accessories page to order brackets.

Power: Surface mount power provides (2) 15 amp receptacles, (1) 2 amp USB-A port, 10 watt and (1) 2 amp USB-C port, 20 watt.

When using a combination of fabrics or leathers, specify the application by designating the appropriate letter, shown below, on the purchase order. Yardage shown must be used.

See terms and conditions for contrasting upholstery upcharges.

- A) One fabric or leather for seat
 yardage: 6.5 yds. leather: 105.0 sq. ft.
- B) One fabric or leather for inside back, outside back, outer shell and inside arms
 yardage: 5.0 yds. leather: 82.0 sq. ft.

SCS Indoor Advantage™ Gold and LEVEL® 2 certified. See terms and conditions for additional finish and environmental information.

Seat Height	Arm Height	W	D	H	Fabric	Leather	Weight	Cubes/Qty
16½"	29½"	90¼"	33¼"	29½"	11.5 yds.	190.0'	212 lbs.	71.85/1
419 mm	749 mm	2286 mm	845 mm	749 mm	10.5 m	17.7 sqm	96.2 kg	2.03 cu.

COM	COL	1	2	3	4	5	6	7	8	9	10	11
6326	6556	7400	7579	7681	7885	8064	8141	8269	8448	8601	8780	9802

sku	frame finish	run-off top species	wood top finish
	6 polished aluminum standard, OR specify powder coat, upcharge \$200 3 matte black powder coat W satin white powder coat	C oak 9 walnut	see seating finishes

luca 8D16L

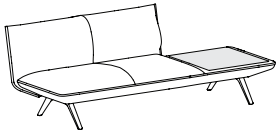

Two-seat armless module with end table
Left side facing
Polished aluminum or powder coat legs
Upholstered

End table available in all oak and walnut finishes. When specifying light finish the natural characteristics of the wood will be visible and color will vary.

Ganging brackets are sold separately and will ship with the product. See Luca accessories page to order brackets.

When using a combination of fabrics or leathers, specify the application by designating the appropriate letter, shown below, on the purchase order. Yardage shown must be used.

See terms and conditions for contrasting upholstery upcharges.

- A) One fabric or leather for seat
 yardage: 6.5 yds. leather: 105.0 sq. ft.
- B) One fabric or leather for inside back and outside back
 yardage: 3.0 yds. leather: 50.0 sq. ft.

SCS Indoor Advantage™ Gold and LEVEL® 2 certified. See terms and conditions for additional finish and environmental information.

Seat Height	Arm Height	W	D	H	Fabric	Leather	Weight	Cubes/Qty
16½"	-	86¼"	33¼"	29 ½"	9.5 yds.	160.0'	195 lbs.	71.85'/1
419 mm	-	2191 mm	845 mm	749 mm	8.7 m	14.9 sqm	88.5 kg	2.03 cu.

COM	COL	1	2	3	4	5	6	7	8	9	10	11
4866	5056	5753	5901	5985	6154	6302	6365	6471	6619	6745	6893	7738

sku	frame finish	run-off top species	wood top finish
	6 polished aluminum standard, OR specify powder coat, upcharge \$200 3 matte black powder coat W satin white powder coat	C oak 9 walnut	see seating finishes

luca 8P16L

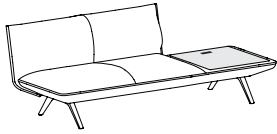

Power
Two-seat armless module with end table
Left side facing
Polished aluminum or powder coat legs
Upholstered

End table available in all oak and walnut finishes. When specifying light finish the natural characteristics of the wood will be visible and color will vary.

Ganging brackets are sold separately and will ship with the product. See Luca accessories page to order brackets.

Power: Surface mount power provides (2) 15 amp receptacles, (1) 2 amp USB-A port, 10 watt and (1) 2 amp USB-C port, 20 watt.

When using a combination of fabrics or leathers, specify the application by designating the appropriate letter, shown below, on the purchase order. Yardage shown must be used.

See terms and conditions for contrasting upholstery upcharges.

- A) One fabric or leather for seat
 yardage: 6.5 yds. leather: 105.0 sq. ft.
- B) One fabric or leather for inside back and outside back
 yardage: 3.0 yds. leather: 50.0 sq. ft.

SCS Indoor Advantage™ Gold and LEVEL® 2 certified. See terms and conditions for additional finish and environmental information.

Seat Height	Arm Height	W	D	H	Fabric	Leather	Weight	Cubes/Qty
16½"	-	86¼"	33¼"	29½"	9.5 yds.	160.0'	198 lbs.	71.85/1
419 mm	-	2191 mm	845 mm	749 mm	8.7 m	14.9 sqm	89.8 kg	2.03 cu.

COM	COL	1	2	3	4	5	6	7	8	9	10	11
5632	5822	6519	6667	6751	6920	7068	7131	7237	7385	7511	7659	8504

sku	frame finish	run-off top species	wood top finish
	6 polished aluminum standard, OR specify powder coat, upcharge \$200 3 matte black powder coat W satin white powder coat	C oak 9 walnut	see seating finishes

luca 8D16R

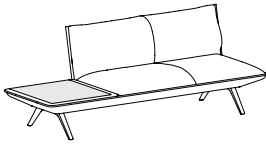

Two-seat armless module with end table
Right side facing
Polished aluminum or powder coat legs
Upholstered

End table available in all oak and walnut finishes. When specifying light finish the natural characteristics of the wood will be visible and color will vary.

Ganging brackets are sold separately and will ship with the product. See Luca accessories page to order brackets.

When using a combination of fabrics or leathers, specify the application by designating the appropriate letter, shown below, on the purchase order. Yardage shown must be used.

See terms and conditions for contrasting upholstery upcharges.

- A) One fabric or leather for seat
 yardage: 6.5 yds. leather: 105.0 sq. ft.
- B) One fabric or leather for inside back and outside back
 yardage: 3.0 yds. leather: 50.0 sq. ft.

SCS Indoor Advantage™ Gold and LEVEL® 2 certified. See terms and conditions for additional finish and environmental information.

Seat Height	Arm Height	W	D	H	Fabric	Leather	Weight	Cubes/Qty
16½"	-	86¼"	33¼"	29½"	9.5 yds.	160.0'	195 lbs.	71.85'/1
419 mm	-	2191 mm	845 mm	749 mm	8.7 m	14.9 sqm	88.5 kg	2.03 cu.

COM	COL	1	2	3	4	5	6	7	8	9	10	11
4866	5056	5753	5901	5985	6154	6302	6365	6471	6619	6745	6893	7738

sku	frame finish	run-off top species	wood top finish
	6 polished aluminum standard, OR specify powder coat, upcharge \$200 3 matte black powder coat W satin white powder coat	C oak 9 walnut	see seating finishes

luca 8P16R

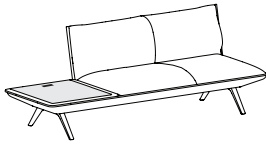

Power
Two-seat armless module with end table
Right side facing
Polished aluminum or powder coat legs
Upholstered

End table available in all oak and walnut finishes. When specifying light finish the natural characteristics of the wood will be visible and color will vary.

Ganging brackets are sold separately and will ship with the product. See Luca accessories page to order brackets.

Power: Surface mount power provides (2) 15 amp receptacles, (1) 2 amp USB-A port, 10 watt and (1) 2 amp USB-C port, 20 watt.

When using a combination of fabrics or leathers, specify the application by designating the appropriate letter, shown below, on the purchase order. Yardage shown must be used.

See terms and conditions for contrasting upholstery upcharges.

- A) One fabric or leather for seat
 yardage: 6.5 yds. leather: 105.0 sq. ft.
- B) One fabric or leather for inside back and outside back
 yardage: 3.0 yds. leather: 50.0 sq. ft.

SCS Indoor Advantage™ Gold and LEVEL® 2 certified. See terms and conditions for additional finish and environmental information.

Seat Height	Arm Height	W	D	H	Fabric	Leather	Weight	Cubes/Qty
16½"	-	86¼"	33¼"	29½"	9.5 yds.	160.0'	198 lbs.	71.85/1
419 mm	-	2191 mm	845 mm	749 mm	8.7 m	14.9 sqm	89.8 kg	2.03 cu.

COM	COL	1	2	3	4	5	6	7	8	9	10	11
5632	5822	6519	6667	6751	6920	7068	7131	7237	7385	7511	7659	8504

sku	frame finish	run-off top species	wood top finish
	6 polished aluminum standard, OR specify powder coat, upcharge \$200 3 matte black powder coat W satin white powder coat	C oak 9 walnut	see seating finishes

luca 8D08N

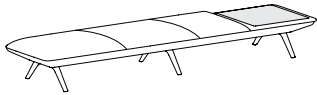

Three-seat bench with end table
Polished aluminum or powder coat legs
Upholstered

End table available in all oak and walnut finishes. When specifying light finish the natural characteristics of the wood will be visible and color will vary.

Ganging brackets are sold separately and will ship with the product. See Luca accessories page to order brackets.

SCS Indoor Advantage™ Gold and LEVEL® 2 certified. See terms and conditions for additional finish and environmental information.

Seat Height	Arm Height	W	D	H	Fabric	Leather	Weight	Cubes/Qty
16½"	-	115¼"	28¾"	16½"	8.5 yds.	140.0'	178 lbs.	50.0'/1
419 mm	-	2921 mm	730 mm	419 mm	7.8 m	13.0 sqm	80.7 kg	1.40 cu.

COM	COL	1	2	3	4	5	6	7	8	9	10	11
3755	3925	4549	4681	4757	4908	5040	5097	5191	5323	5437	5569	6324

luca 8P08N

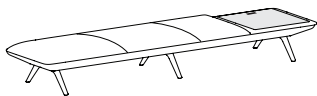

Power
Three-seat bench with end table
Polished aluminum or powder coat legs
Upholstered

End table available in all oak and walnut finishes. When specifying light finish the natural characteristics of the wood will be visible and color will vary.

Ganging brackets are sold separately and will ship with the product. See Luca accessories page to order brackets. .

Power: Surface mount power provides (2) 15 amp receptables, (1) 2 amp USB-A port, 10 watt and (1) 2 amp USB-C port, 20 watt.

SCS Indoor Advantage™ Gold and LEVEL® 2 certified. See terms and conditions for additional finish and environmental information.

Seat Height	Arm Height	W	D	H	Fabric	Leather	Weight	Cubes/Qty
16½"	-	115¼"	28¾"	16½"	8.5 yds.	140.0'	181 lbs.	50.0'/1
419 mm	-	2921 mm	730 mm	419 mm	7.8 m	13.0 sqm	82.1 kg	1.40 cu.

COM	COL	1	2	3	4	5	6	7	8	9	10	11
4519	4689	5313	5445	5521	5672	5804	5861	5955	6087	6201	6333	7088

sku	frame finish	run-off top species	wood top finish
	6 polished aluminum standard, OR specify powder coat, upcharge \$200 3 matte black powder coat W satin white powder coat	C oak 9 walnut	see seating finishes

luca 8D06N

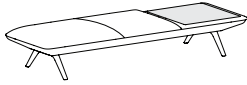

Two-seat bench with end table
Polished aluminum or powder coat legs
Upholstered

End table available in all oak and walnut finishes. When specifying light finish the natural characteristics of the wood will be visible and color will vary.

Ganging brackets are sold separately and will ship with the product. See Luca accessories page to order brackets.

SCS Indoor Advantage™ Gold and LEVEL® 2 certified. See terms and conditions for additional finish and environmental information.

Seat Height	Arm Height	W	D	H	Fabric	Leather	Weight	Cubes/Qty
16½"	-	86¼"	28¾"	16½"	6.75 yds.	110.0'	140 lbs.	37.6'/1
419 mm	-	2191 mm	730 mm	419 mm	6.2 m	10.2 sqm	63.5 kg	1.10 cu.

COM	COL	1	2	3	4	5	6	7	8	9	10	11
3198	3333	3828	3933	3993	4113	4218	4263	4338	4443	4533	4638	5238

luca 8P06N

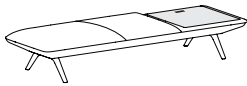

Power
Two-seat bench with end table
Polished aluminum or powder coat legs
Upholstered

End table available in all oak and walnut finishes. When specifying light finish the natural characteristics of the wood will be visible and color will vary.

Ganging brackets are sold separately and will ship with the product. See Luca accessories page to order brackets.

Power: Surface mount power provides (2) 15 amp receptacles, (1) 2 amp USB-A port, 10 watt and (1) 2 amp USB-C port, 20 watt.

SCS Indoor Advantage™ Gold and LEVEL® 2 certified. See terms and conditions for additional finish and environmental information.

Seat Height	Arm Height	W	D	H	Fabric	Leather	Weight	Cubes/Qty
16½"	-	86¼"	28¾"	16½"	6.75 yds.	110.0'	143 lbs.	37.6'/1
419 mm	-	2191 mm	730 mm	419 mm	6.2 m	10.2 sqm	64.9 kg	1.10 cu.

COM	COL	1	2	3	4	5	6	7	8	9	10	11
3963	4098	4593	4698	4758	4878	4983	5028	5103	5208	5298	5403	6003

sku	frame finish	run-off top species	wood top finish
	6 polished aluminum standard, OR specify powder coat, upcharge \$150 3 matte black powder coat W satin white powder coat	C oak 9 walnut	see seating finishes

luca 8D01N



Module bench
Polished aluminum or powder coat legs
Upholstered

Ganging brackets are sold separately and will ship with the product. See Luca accessories page to order brackets.

SCS Indoor Advantage™ Gold and LEVEL® 2 certified. See terms and conditions for additional environmental information.

Seat Height	Arm Height	W	D	H	Fabric	Leather	Weight	Cubes/Qty
16½"	-	45¼"	28¾"	16½"	3.5 yds.	57.0'	78 lbs.	25.67'/1
419 mm	-	1149 mm	730 mm	419 mm	3.2 m	5.3 sqm	35.4 kg	.73 cu.

COM	COL	1	2	3	4	5	6	7	8	9	10	11
1809	1879	2136	2191	2222	2284	2338	2362	2401	2455	2502	2556	2867

luca 8D05N

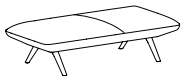

Two-seat module bench
Polished aluminum or powder coat legs
Upholstered

Ganging brackets are sold separately and will ship with the product. See Luca accessories page to order brackets.

SCS Indoor Advantage™ Gold and LEVEL® 2 certified. See terms and conditions for additional environmental information.

Seat Height	Arm Height	W	D	H	Fabric	Leather	Weight	Cubes/Qty
16½"	-	58½"	28¾"	16½"	5 yds.	81.0'	91 lbs.	25.67'/1
419 mm	-	1486 mm	730 mm	419 mm	4.6 m	7.5 sqm	41.3 kg	.73 cu.

COM	COL	1	2	3	4	5	6	7	8	9	10	11
2225	2325	2692	2770	2814	2903	2981	3014	3070	3148	3214	3292	3737

sku

--	--	--	--	--	--	--	--	--	--	--	--	--

frame finish

- 6** polished aluminum standard, OR
- specify powder coat, upcharge \$150
- 3** matte black powder coat
- W** satin white powder coat

--

luca 8D07N

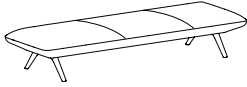

Three-seat module bench
Polished aluminum or powder coat legs
Upholstered

Ganging brackets are sold separately and will ship with the product. See Luca accessories page to order brackets.

SCS Indoor Advantage™ Gold and LEVEL® 2 certified. See terms and conditions for additional environmental information.

Seat Height	Arm Height	W	D	H	Fabric	Leather	Weight	Cubes/Qty
16½"	-	87¼"	28¾"	16½"	7.25 yds.	118.0'	121 lbs	37.6'/1
419 mm	-	2216 mm	730 mm	419 mm	6.6 m	11.0 sqm	54.9 kg	1.10 cu.

COM	COL	1	2	3	4	5	6	7	8	9	10	11
2642	2787	3319	3432	3496	3625	3738	3786	3867	3980	4076	4189	4834

luca 8D02N

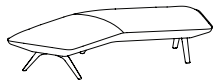

45° Modular bench
Polished aluminum or powder coat legs
Upholstered

Ganging brackets are sold separately and will ship with the product. See Luca accessories page to order brackets.

SCS Indoor Advantage™ Gold and LEVEL® 2 certified. See terms and conditions for additional environmental information.

Seat Height	Arm Height	W	D	H	Fabric	Leather	Weight	Cubes/Qty
16½"	-	80½"	40¼"	16½"	4.75 yds.	78.0'	119 lbs.	45.45'/1
419 mm	-	2045 mm	1022 mm	419 mm	4.3 m	7.2 sqm	54.0 kg	1.30 cu.

COM	COL	1	2	3	4	5	6	7	8	9	10	11
2642	2737	3086	3160	3202	3286	3360	3392	3445	3519	3582	3656	4078

sku

--	--	--	--	--	--

frame finish

- 6** polished aluminum standard, OR
- specify powder coat, upcharge \$150*
- 3** matte black powder coat
- W** satin white powder coat

--

luca 8D09N

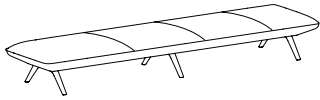

Four-seat module bench
Polished aluminum or powder coat legs
Upholstered

Ganging brackets are sold separately and will ship with product. See Luca accessories page to order brackets

SCS Indoor Advantage™ Gold and LEVEL® 2 certified. See terms and conditions for additional environmental information.

Seat Height	Arm Height	W	D	H	Fabric	Leather	Weight	Cubes/Qty
16½"	-	117"	28¾"	16½"	9.5 yds.	154.0'	159 lbs.	50.0'/1
419 mm	-	2972 mm	730 mm	419 mm	8.7 m	14.3 sqm	72.1 kg	1.40 cu.

COM	COL	1	2	3	4	5	6	7	8	9	10	11
3338	3528	4225	4373	4457	4626	4774	4837	4943	5091	5217	5365	6210

luca 8D32N

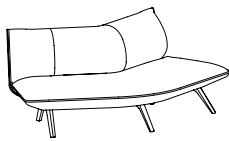

Outside 45° corner module
Armless
Polished aluminum or powder coat legs
Upholstered

Ganging brackets are sold separately and will ship with the product. See Luca accessories page to order brackets.

When using a combination of fabrics or leathers, specify the application by designating the appropriate letter, shown below, on the purchase order. Yardage shown must be used.

See terms and conditions for contrasting upholstery upcharges.

- A) One fabric or leather for seat
yardage: 5.5 yds. leather: 90.0 sq. ft.
- B) One fabric or leather for inside back and outside back
yardage: 5.25 yds. leather: 85.0 sq. ft.

SCS Indoor Advantage™ Gold and LEVEL® 2 certified. See terms and conditions for additional environmental information.

Seat Height	Arm Height	W	D	H	Fabric	Leather	Weight	Cubes/Qty
16½"	-	81¼"	44½"	29½"	9.25 yds.	150.0'	160 lbs.	84.29'/1
419 mm	-	2064 mm	1130 mm	749 mm	8.5 m	13.0 sqm	72.6 kg	2.40 cu.

COM	COL	1	2	3	4	5	6	7	8	9	10	11
4866	5051	5730	5874	5956	6120	6264	6326	6429	6573	6696	6840	7662

sku

frame finish

--	--	--	--	--	--	--	--	--	--	--	--	--

- 6** polished aluminum standard, OR
- specify powder coat, upcharge \$200
- 3** matte black powder coat
- W** satin white powder coat

luca 8D31N

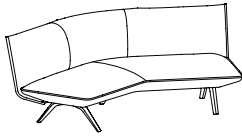

Inside 45° corner module
Armless
Polished aluminum or powder coat legs
Upholstered

Ganging brackets are sold separately and will ship with the product. See Luca accessories page to order brackets.

When using a combination of fabrics or leathers, specify the application by designating the appropriate letter, shown below, on the purchase order. Yardage shown must be used.

See terms and conditions for contrasting upholstery upcharges.

- A) One fabric or leather for seat
 yardage: 5.5 yds. leather: 90.0 sq. ft.
- B) One fabric or leather for inside back and outside back
 yardage: 7.25 yds. leather: 118.0 sq. ft.

SCS Indoor Advantage™ Gold and LEVEL® 2 certified. See terms and conditions for additional environmental information.

Seat Height	Arm Height	W	D	H	Fabric	Leather	Weight	Cubes/Qty
16½"	-	85"	44½"	29½"	11.75 yds.	190.0'	197 lbs.	84.29/1
419 mm	-	2159 mm	1130 mm	749 mm	10.7 m	17.6 sqm	89.4 kg	2.40 cu.

COM	COL	1	2	3	4	5	6	7	8	9	10	11
5561	5796	6658	6841	6945	7154	7337	7415	7546	7729	7885	8068	9113

luca 8D33L

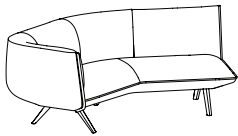

Inside 45° corner module
Left arm facing
Polished aluminum or powder coat legs
Upholstered

Ganging brackets are sold separately and will ship with the product. See Luca accessories page to order brackets.

When using a combination of fabrics or leathers, specify the application by designating the appropriate letter, shown below, on the purchase order. Yardage shown must be used.

See terms and conditions for contrasting upholstery upcharges.

- A) One fabric or leather for seat
 yardage: 5.0 yds. leather: 82.0 sq. ft.
- B) One fabric or leather for inside back and outside back, outer shell and inside arms
 yardage: 8.5 yds. leather: 140.0 sq. ft.

SCS Indoor Advantage™ Gold and LEVEL® 2 certified. See terms and conditions for additional environmental information.

Seat Height	Arm Height	W	D	H	Fabric	Leather	Weight	Cubes/Qty
16½"	29½"	86¼"	44½"	29½"	13.25 yds.	215.0'	199 lbs.	84.29/1
419 mm	749 mm	2191 mm	1130 mm	749 mm	12.1 m	20.0 sqm	90.3 kg	2.40 cu.

COM	COL	1	2	3	4	5	6	7	8	9	10	11
6117	6382	7354	7560	7678	7914	8120	8208	8355	8561	8738	8944	10122

sku

frame finish

--	--	--	--	--	--	--	--	--	--	--	--	--

- 6** polished aluminum standard, OR
 specify powder coat, upcharge \$200
- 3** matte black powder coat
- W** satin white powder coat

luca 8D33R

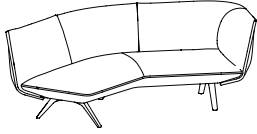

Inside 45° corner module
Right arm facing
Polished aluminum or powder coat legs
Upholstered

Ganging brackets are sold separately and will ship with the product. See Luca accessories page to order brackets.

When using a combination of fabrics or leathers, specify the application by designating the appropriate letter, shown below, on the purchase order. Yardage shown must be used.

See terms and conditions for contrasting upholstery upcharges.

- A) One fabric or leather for seat
 yardage: 5.0 yds. leather: 82.0 sq. ft.
- B) One fabric or leather for inside back and outside back, outer shell and inside arm
 yardage: 8.5 yds. leather: 140.0 sq. ft.

SCS Indoor Advantage™ Gold and LEVEL® 2 certified. See terms and conditions for additional environmental information.

Seat Height	Arm Height	W	D	H	Fabric	Leather	Weight	Cubes/Qty
16½"	29½"	86¼"	44½"	29½"	13.25 yds.	215.0'	199 lbs.	84.29/1
419 mm	749 mm	2191 mm	1130 mm	749 mm	12.1 m	20.0 sqm	90.3 kg	2.40 cu.

COM	COL	1	2	3	4	5	6	7	8	9	10	11
6117	6382	7354	7560	7678	7914	8120	8208	8355	8561	8738	8944	10122

sku

--	--	--	--	--	--	--	--	--	--	--	--	--

frame finish

- 6** polished aluminum standard, OR
- specify powder coat, upcharge \$200
- 3** matte black powder coat
- W** satin white powder coat

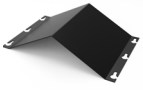
description	sku	w	d	h	price
 <p>ganging bracket Order one ganging bracket per point of connection of modular units. Ganging brackets are sold separately and will ship with product.</p>	111	14½	9½	3½	\$ 108

series

sku

8 | D |

1 | 1 | 1 |

Mirador Seating System Specification Guide

Mirador is a modular seating product comprised of 63 unique modules, which may be used interchangeably to create an unlimited number of configurations. To select the modules that are appropriate for your application use the four steps listed below.

Please visit BernhardtDesign.com for a complete library of 2D and 3D models. You may also contact your local sales representative or the Bernhardt Design corporate office for specification assistance. Mirador is fully upholstered with a polished cast aluminum frame with levelers and non-marring glides.

When ordering multi-item configurations, please provide the total COM yardage from the same dye lot in a continuous roll(s). *All COM/COL fabrics must be preapproved by Bernhardt Design prior to application. See terms and conditions for instructions on tagging COM. Specify fabric railroaded when used with Item 5905 corner module.

All necessary ganging brackets are included and pre-installed. SCS Indoor Advantage™ Gold and LEVEL® 2 certified. See terms and conditions for additional environmental information.

Four Step Selection Process

Step 1 - Front Selection

Sofa and Settee modules are available with two different front conditions.

A - Flared Fronts

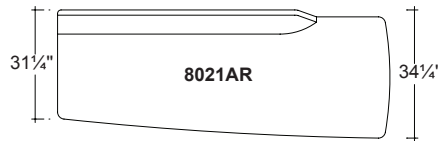
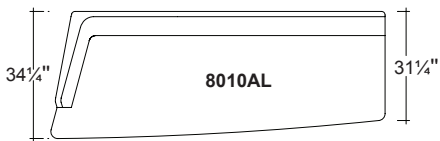

B - Non-Flared Fronts

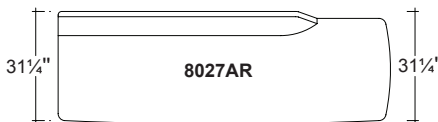
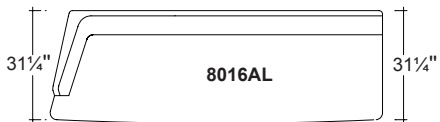

Step 2 - Arm Selection

Sofa and Settee modules are available with arms or without arms.

A - Arm Module

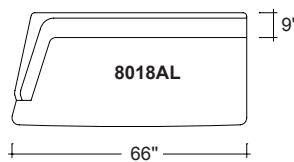
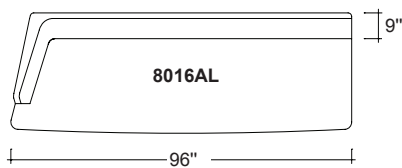

B - Armless Module

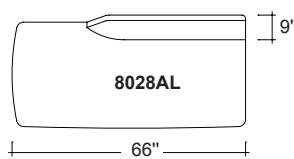
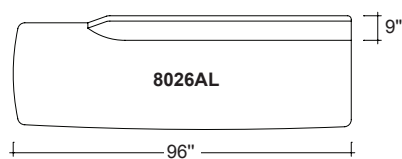

Mirador Seating System Specification Guide

Step 3 - End Selection

Sofa and Settee modules are available with three unique end conditions. The selection of an end condition is used to achieve different angles when connecting multiple modules.

A - Straight Ends are specified for creating a configuration in a straight line 180°.

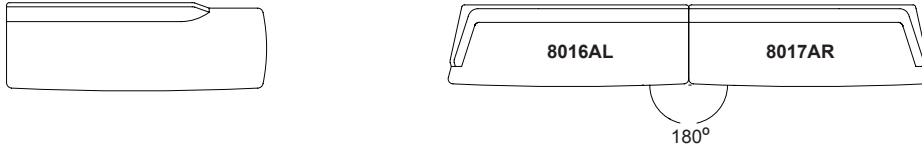

B - Open Angle Ends are specified for opening up a configuration and achieving an angle which is greater than 180°.

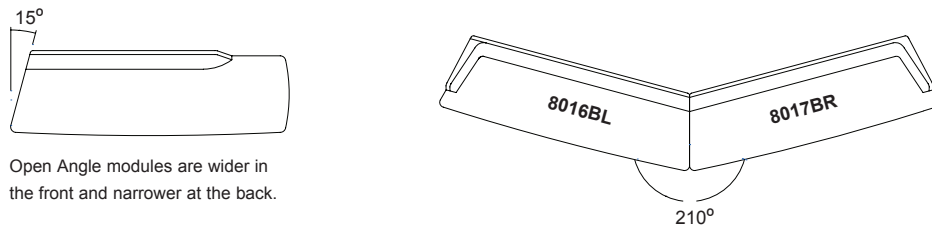

Open Angle modules are wider in the front and narrower at the back.

C - Closed Angle Ends are specified for closing up a configuration and achieving an angle which is less than 180°.

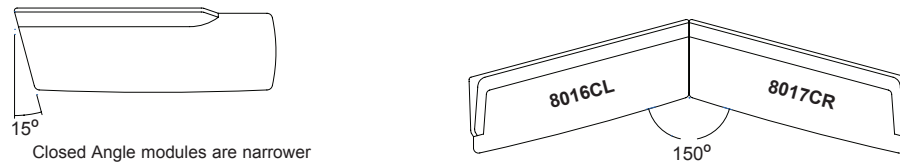

Closed Angle modules are narrower in the front and wider at the back.

Modules with different end conditions may be connected to achieve the appropriate angle.

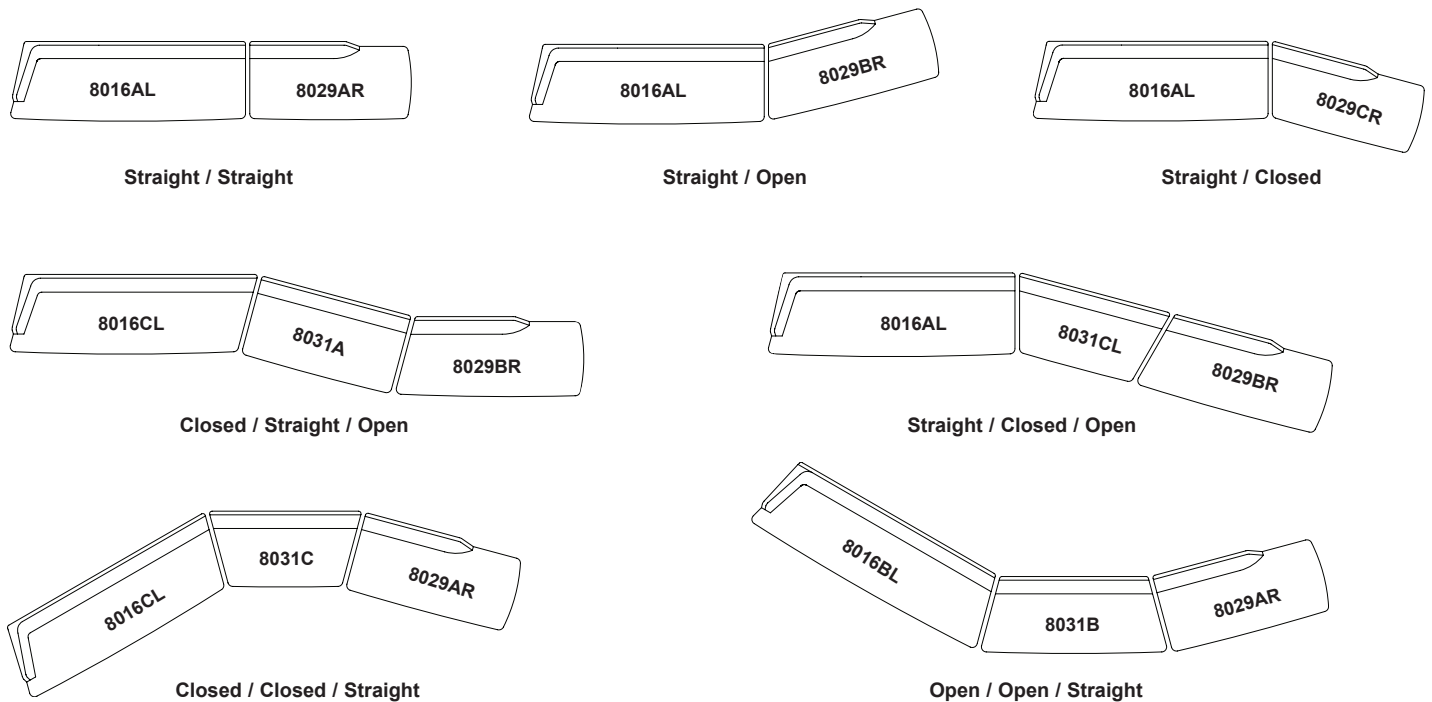

Mirador Seating System Specification Guide

Step 4 - Connecting Module Selection

A - Specifying connecting modules to achieve a desired length.

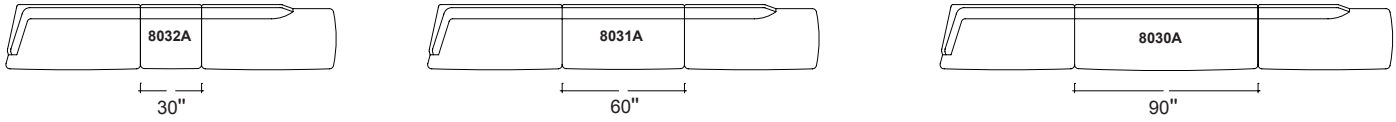

B - Specifying connection modules to achieve a desired angle.

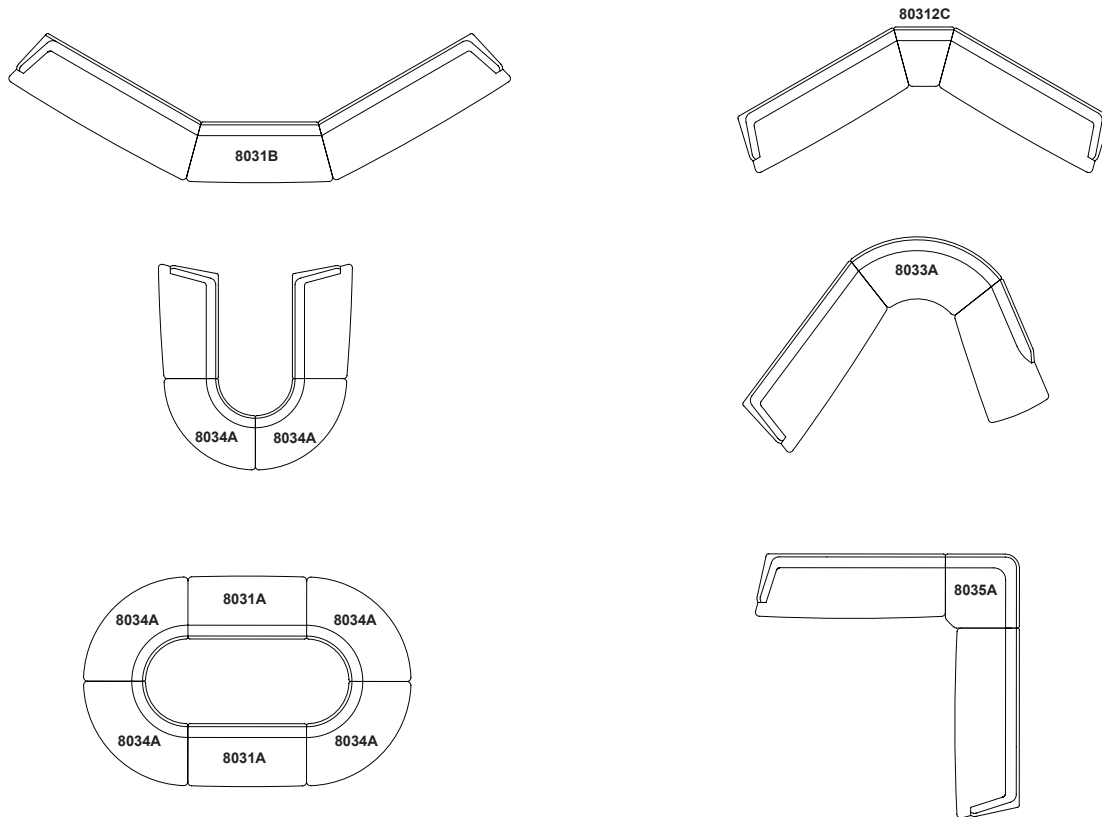

Twelve unique connecting modules are available to alter both the length and the angle of a configuration.

Straight Connecting Modules



Open Angle Connecting Modules



Closed Angle Connecting Modules



Mirador Seating System Sample Configurations

SKU Description

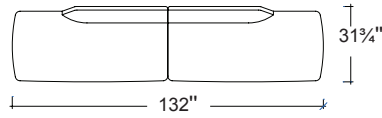
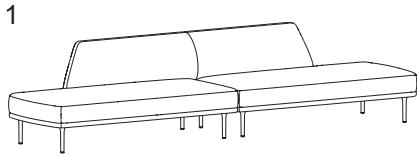

8028AL Left Armless
8029AR Right Armless

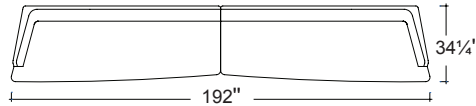
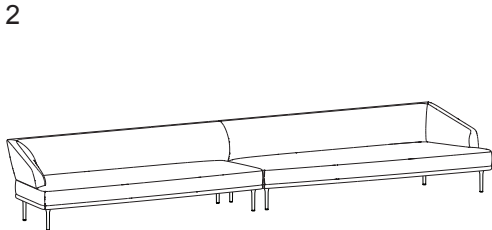

8010AL Left Arm
8011AR Right Arm

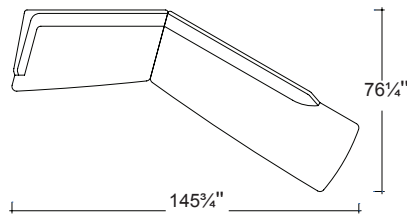
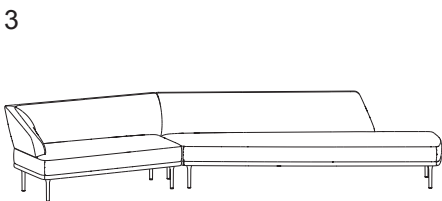

8012CL Left Arm
8021CR Right Armless

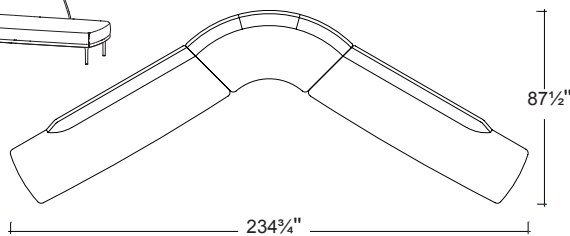
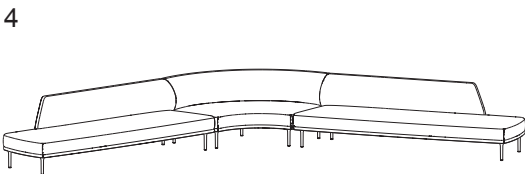

8026BL Left Armless
8033A Inside Quarter Round
8027BR Right Armless

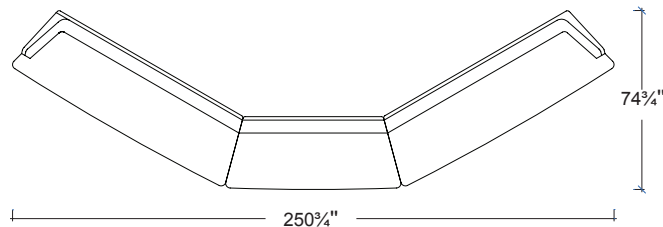
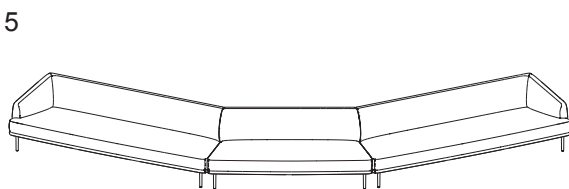

8016BL Left Arm
8031B Connecting Module
8017BR Right Arm

Mirador Seating System Sample Configurations

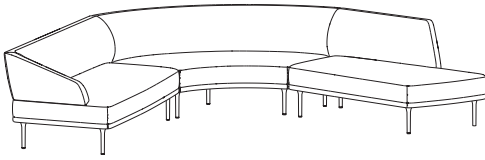
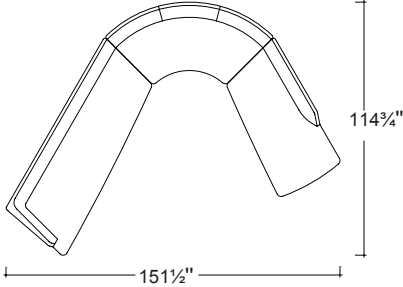
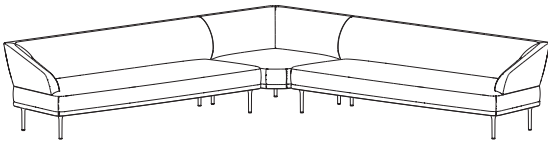
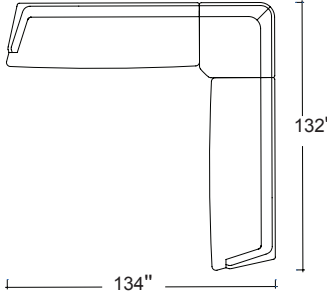
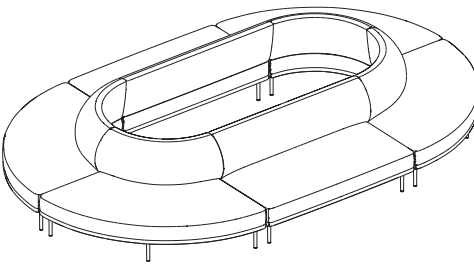
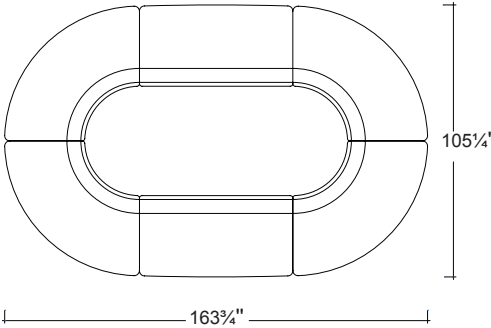
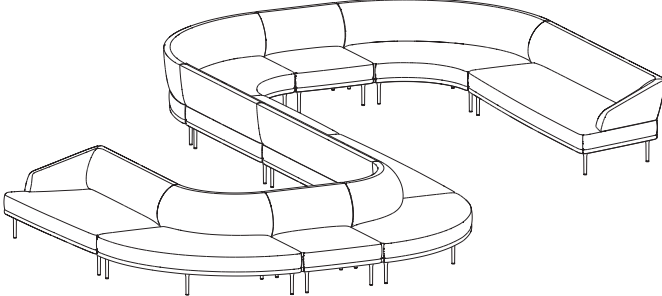
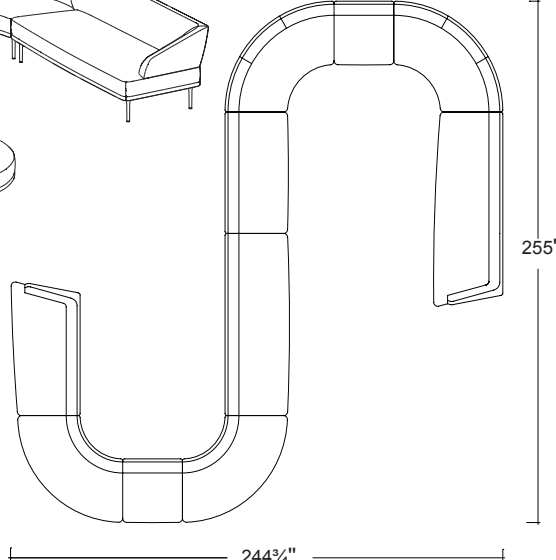
6	Sku	Description
 	<p>8010CL 8033A 8023CR</p>	<p>Left Arm Inside Quarter Round Right Armless</p>
7	<p>8016AL 8035A 8017AR</p>	<p>Left Arm Corner Right Arm</p>
 		
8	<p>8034A 8031A</p>	<p>Outside Quarter Round (4) Connecting Module (2)</p>
 		
9	<p>8011AR 8033A 8032A 8031A 8030A 8034A 8012AL</p>	<p>Right Arm Inside Quarter Round (2) Connecting One-Seat (2) Connecting Two-Seat Connecting Three-Seat Outside Quarter Round (2) Left Arm</p>
 		

Mirador Seating System Product Overview

Flared Front Sofa and Settee

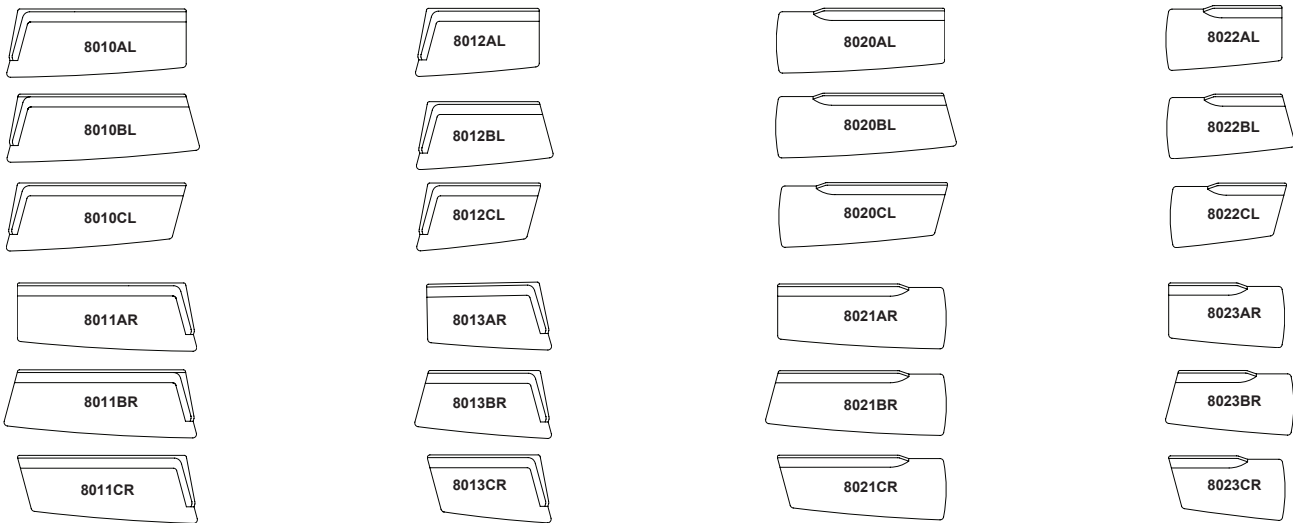

Non-Flared Front Sofa and Settee

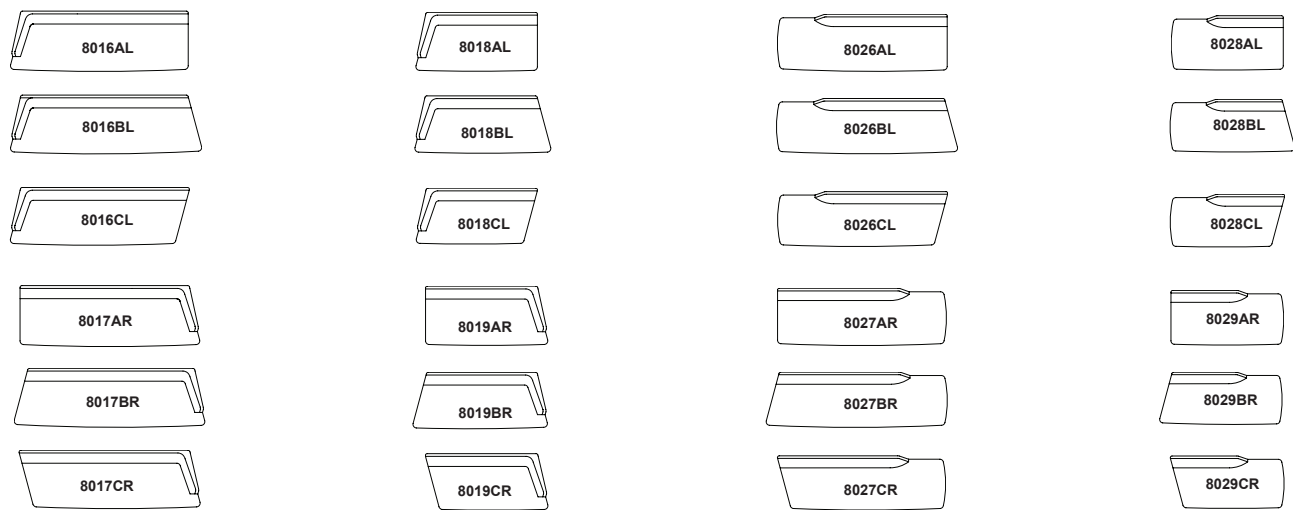

Connecting Module



Freestanding Bench

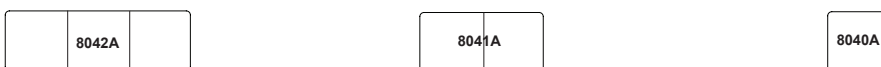

flared front sofa - arm



mirador 8010AL

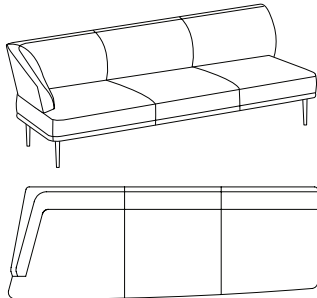

Three-seat module
Left arm facing
Straight end
Polished aluminum base
Upholstered

All necessary ganging brackets are included and pre-installed

When using a combination of fabrics or leathers, specify the application by designating the appropriate letter, shown below, on the purchase order. Yardage shown must be used.

See terms and conditions for contrasting upholstery upcharges.

- A) One fabric or leather for seat cushion
yardage: 7.5 yds. leather: 122.0 sq. ft.
- B) One fabric or leather for inside back, outside back and side arm
yardage: 5.75 yds. leather: 95.0 sq. ft.

SCS Indoor Advantage™ Gold and LEVEL® 2 certified. See terms and conditions for additional environmental information.

Seat Height	Arm Height	W	D	H	Fabric	Leather	Weight	Cubes/Qty
16½"	21½"-29"	96"	31¼"-34¼"	29"	11.25 yds.	160.0'	221 lbs.	101.65'/1
419 mm	546-737 mm	2438 mm	794-870 mm	737 mm	10.3 m	14.9 sqm	100.5 kg	2.88 cu.

COM	COL	1	2	3	4	5	6	7	8	9	10	11
6219	6444	7269	7444	7544	7744	7919	7994	8119	8294	8444	8619	9619

mirador 8010BL

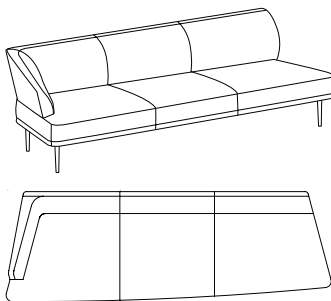

Three-seat module
Left arm facing
Open angle end
Polished aluminum base
Upholstered

All necessary ganging brackets are included and pre-installed

When using a combination of fabrics or leathers, specify the application by designating the appropriate letter, shown below, on the purchase order. Yardage shown must be used.

See terms and conditions for contrasting upholstery upcharges.

- A) One fabric or leather for seat cushion
yardage: 7.5 yds. leather: 122.0 sq. ft.
- B) One fabric or leather for inside back, outside back and side arm
yardage: 5.75 yds. leather: 95.0 sq. ft.

SCS Indoor Advantage™ Gold and LEVEL® 2 certified. See terms and conditions for additional environmental information.

Seat Height	Arm Height	W	D	H	Fabric	Leather	Weight	Cubes/Qty
16½"	21½"-29"	103"	31¼"-34¼"	29"	11.25 yds.	160.0'	221 lbs.	97.97'/1
419 mm	546-737 mm	2616 mm	794-870 mm	737 mm	10.3 m	14.9 sqm	100.5 kg	2.78 cu.

COM	COL	1	2	3	4	5	6	7	8	9	10	11
6219	6444	7269	7444	7544	7744	7919	7994	8119	8294	8444	8619	9619

flared front sofa - arm

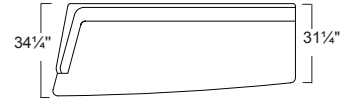

mirador 8010CL

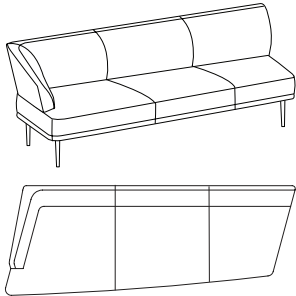

Three-seat module
Left arm facing
Closed angle end
Polished aluminum base
Upholstered

All necessary ganging brackets are included and pre-installed

When using a combination of fabrics or leathers, specify the application by designating the appropriate letter, shown below, on the purchase order. Yardage shown must be used.

See terms and conditions for contrasting upholstery upcharges.

- A) One fabric or leather for seat cushion
yardage: 7.5 yds. leather: 122.0 sq. ft.
- B) One fabric or leather for inside back, outside back and side arm
yardage: 5.75 yds. leather: 95.0 sq. ft.

SCS Indoor Advantage™ Gold and LEVEL® 2 certified. See terms and conditions for additional environmental information.

Seat Height	Arm Height	W	D	H	Fabric	Leather	Weight	Cubes/Qty
16½"	21½"-29"	96"	31¼"-34¼"	29"	11.25 yds.	160.0'	224 lbs.	97.97'/1
419 mm	546-737 mm	2438 mm	794-870 mm	737 mm	10.3 m	14.9 sqm	101.8 kg	97.97'/1

COM	COL	1	2	3	4	5	6	7	8	9	10	11
6219	6444	7269	7444	7544	7744	7919	7994	8119	8294	8444	8619	9619

mirador 8011AR

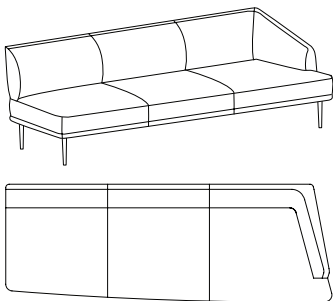

Three-seat module
Right arm facing
Straight end
Polished aluminum base
Upholstered

All necessary ganging brackets are included and pre-installed

When using a combination of fabrics or leathers, specify the application by designating the appropriate letter, shown below, on the purchase order. Yardage shown must be used.

See terms and conditions for contrasting upholstery upcharges.

- A) One fabric or leather for seat cushion
yardage: 7.5 yds. leather: 122.0 sq. ft.
- B) One fabric or leather for inside back, outside back and side arm
yardage: 5.75 yds. leather: 95.0 sq. ft.

SCS Indoor Advantage™ Gold and LEVEL® 2 certified. See terms and conditions for additional environmental information.

Seat Height	Arm Height	W	D	H	Fabric	Leather	Weight	Cubes/Qty
16½"	21½"-29"	96"	31¼"-34¼"	29"	11.25 yds.	160.0'	221 lbs.	101.65'/1
419 mm	546-737 mm	2438 mm	794-870 mm	737 mm	10.3 m	14.9 sqm	100.5 kg	2.88 cu.

COM	COL	1	2	3	4	5	6	7	8	9	10	11
6219	6444	7269	7444	7544	7744	7919	7994	8119	8294	8444	8619	9619

flared front sofa - arm

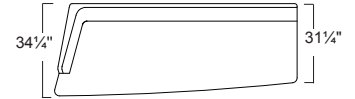

mirador 8011BR

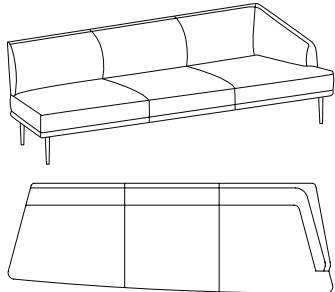

Three-seat module
Right arm facing
Open angle end
Polished aluminum base
Upholstered

All necessary ganging brackets are included and pre-installed

When using a combination of fabrics or leathers, specify the application by designating the appropriate letter, shown below, on the purchase order. Yardage shown must be used.

See terms and conditions for contrasting upholstery upcharges.

- A) One fabric or leather for seat cushion
yardage: 7.5 yds. leather: 122.0 sq. ft.
- B) One fabric or leather for inside back, outside back and side arm
yardage: 5.75 yds. leather: 95.0 sq. ft.

SCS Indoor Advantage™ Gold and LEVEL® 2 certified. See terms and conditions for additional environmental information.

Seat Height	Arm Height	W	D	H	Fabric	Leather	Weight	Cubes/Qty
16½"	21½ -29"	103"	31¼ -34¼"	29"	11.25 yds.	160.0'	224 lbs.	97.97'/1
419 mm	546-737 mm	2616 mm	794-870 mm	737 mm	10.3 m	14.9 sqm	101.8 kg	2.77 cu.

COM	COL	1	2	3	4	5	6	7	8	9	10	11
6219	6444	7269	7444	7544	7744	7919	7994	8119	8294	8444	8619	9619

mirador 8011CR

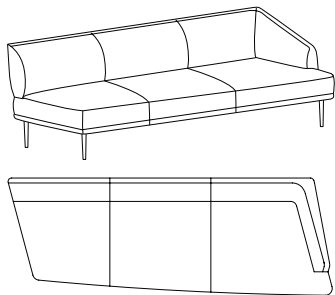

Three-seat module
Right arm facing
Closed angle end
Polished aluminum base
Upholstered

All necessary ganging brackets are included and pre-installed

When using a combination of fabrics or leathers, specify the application by designating the appropriate letter, shown below, on the purchase order. Yardage shown must be used.

See terms and conditions for contrasting upholstery upcharges.

- A) One fabric or leather for seat cushion
yardage: 7.5 yds. leather: 122.0 sq. ft.
- B) One fabric or leather for inside back, outside back and side arm
yardage: 5.75 yds. leather: 95.0 sq. ft.

SCS Indoor Advantage™ Gold and LEVEL® 2 certified. See terms and conditions for additional environmental information.

Seat Height	Arm Height	W	D	H	Fabric	Leather	Weight	Cubes/Qty
16½"	21½ -29"	96"	31¼ -34¼"	29"	11.25 yds.	160.0'	221 lbs.	101.65'/1
419 mm	546-737 mm	2438 mm	794-870 mm	737 mm	10.3 m	14.9 sqm	100.5 kg	2.88 cu.

COM	COL	1	2	3	4	5	6	7	8	9	10	11
6219	6444	7269	7444	7544	7744	7919	7994	8119	8294	8444	8619	9619



mirador 8012AL

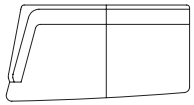

Two-seat module
Left arm facing
Straight end
Polished aluminum base
Upholstered

All necessary ganging brackets are included and pre-installed

When using a combination of fabrics or leathers, specify the application by designating the appropriate letter, shown below, on the purchase order. Yardage shown must be used.

See terms and conditions for contrasting upholstery upcharges.

- A) One fabric or leather for seat cushion
 yardage: 5.5 yds. leather: 90.0 sq. ft.
- B) One fabric or leather for inside back, outside back and side arm
 yardage: 4.25 yds. leather: 70.0 sq. ft.

SCS Indoor Advantage™ Gold and LEVEL® 2 certified. See terms and conditions for additional environmental information.

Seat Height	Arm Height	W	D	H	Fabric	Leather	Weight	Cubes/Qty
16½"	21½"-29"	66"	31¼"-34¼"	29"	8.5 yds.	144.0'	152 lbs.	68.33'/1
419 mm	546-737 mm	1676 mm	794-870 mm	737 mm	7.8 m	13.4 sqm	69.1 kg	1.93 cu.

COM	COL	1	2	3	4	5	6	7	8	9	10	11
4978	5148	5772	5904	5980	6131	6263	6320	6414	6546	6660	6792	7547

mirador 8012BL

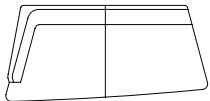
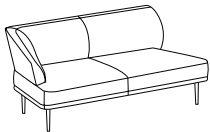

Two-seat module
Left arm facing
Open angle end
Polished aluminum base
Upholstered

All necessary ganging brackets are included and pre-installed

When using a combination of fabrics or leathers, specify the application by designating the appropriate letter, shown below, on the purchase order. Yardage shown must be used.

See terms and conditions for contrasting upholstery upcharges.

- A) One fabric or leather for seat cushion
 yardage: 5.5 yds. leather: 90.0 sq. ft.
- B) One fabric or leather for inside back, outside back and side arm
 yardage: 4.25 yds. leather: 70.0 sq. ft.

SCS Indoor Advantage™ Gold and LEVEL® 2 certified. See terms and conditions for additional environmental information.

Seat Height	Arm Height	W	D	H	Fabric	Leather	Weight	Cubes/Qty
16½"	21½"-29"	73"	31¼"-34¼"	29"	8.5 yds.	144.0'	155 lbs.	80.67'/1
419 mm	21½"-29"	1854 mm	794-870 mm	737 mm	7.8 m	13.4 sqm	70.5 kg	2.28 cu.

COM	COL	1	2	3	4	5	6	7	8	9	10	11
4978	5148	5772	5904	5980	6131	6263	6320	6414	6546	6660	6792	7547

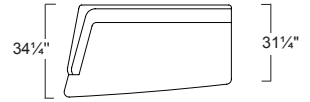

mirador 8012CL

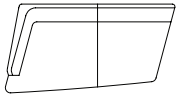
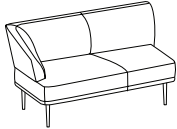

Two-seat module
Left arm facing
Closed angle end
Polished aluminum base
Upholstered

All necessary ganging brackets are included and pre-installed

When using a combination of fabrics or leathers, specify the application by designating the appropriate letter, shown below, on the purchase order. Yardage shown must be used.

See terms and conditions for contrasting upholstery upcharges.

- A) One fabric or leather for seat cushion
 yardage: 5.5 yds. leather: 90.0 sq. ft.
- B) One fabric or leather for inside back, outside back and side arm
 yardage: 4.25 yds. leather: 70.0 sq. ft.

SCS Indoor Advantage™ Gold and LEVEL® 2 certified. See terms and conditions for additional environmental information.

Seat Height	Arm Height	W	D	H	Fabric	Leather	Weight	Cubes/Qty
16½"	21½ -29"	66"	31¼ -34¼"	29"	8.5 yds.	144.0'	152 lbs.	68.33'/1
419 mm	546-737 mm	1676 mm	794-870 mm	737 mm	7.8 m	13.4 sqm	69.1 kg	1.93 cu.

COM	COL	1	2	3	4	5	6	7	8	9	10	11
4978	5148	5772	5904	5980	6131	6263	6320	6414	6546	6660	6792	7547

mirador 8013AR

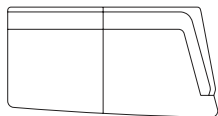
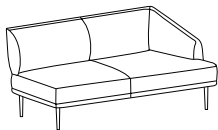

Two-seat module
Right arm facing
Straight end
Polished aluminum base
Upholstered

All necessary ganging brackets are included and pre-installed

When using a combination of fabrics or leathers, specify the application by designating the appropriate letter, shown below, on the purchase order. Yardage shown must be used.

See terms and conditions for contrasting upholstery upcharges.

- A) One fabric or leather for seat cushion
 yardage: 5.5 yds. leather: 90.0 sq. ft.
- B) One fabric or leather for inside back, outside back and side arm
 yardage: 4.25 yds. leather: 70.0 sq. ft.

SCS Indoor Advantage™ Gold and LEVEL® 2 certified. See terms and conditions for additional environmental information.

Seat Height	Arm Height	W	D	H	Fabric	Leather	Weight	Cubes/Qty
16½"	21½ -29"	66"	31¼ -34¼"	29"	8.5 yds.	144.0'	152 lbs.	68.33'/1
419 mm	546-737 mm	1676 mm	794-870 mm	737 mm	7.8 m	13.4 sqm	69.1 kg	1.93 cu.

COM	COL	1	2	3	4	5	6	7	8	9	10	11
4978	5148	5772	5904	5980	6131	6263	6320	6414	6546	6660	6792	7547



mirador 8013BR

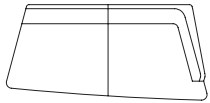
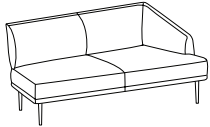

Two-seat module
Right arm facing
Open angle end
Polished aluminum base
Upholstered

All necessary ganging brackets are included and pre-installed

When using a combination of fabrics or leathers, specify the application by designating the appropriate letter, shown below, on the purchase order. Yardage shown must be used.

See terms and conditions for contrasting upholstery upcharges.

- A) One fabric or leather for seat cushion
 yardage: 5.5 yds. leather: 90.0 sq. ft.
- B) One fabric or leather for inside back, outside back and side arm
 yardage: 4.25 yds. leather: 70.0 sq. ft.

SCS Indoor Advantage™ Gold and LEVEL® 2 certified. See terms and conditions for additional environmental information.

Seat Height	Arm Height	W	D	H	Fabric	Leather	Weight	Cubes/Qty
16½"	21½"-29"	73"	31¼"-34¼"	29"	8.5 yds.	144.0'	155 lbs.	80.67'/1
419 mm	546-737 mm	1854 mm	794-870 mm	737 mm	7.8 m	13.4 sqm	70.5 kg	2.28 cu.

COM	COL	1	2	3	4	5	6	7	8	9	10	11
4978	5148	5772	5904	5980	6131	6263	6320	6414	6546	6660	6792	7547

mirador 8013CR

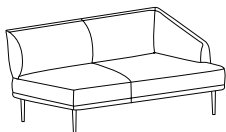

Two-seat module
Right arm facing
Closed angle end
Polished aluminum base
Upholstered

All necessary ganging brackets are included and pre-installed

When using a combination of fabrics or leathers, specify the application by designating the appropriate letter, shown below, on the purchase order. Yardage shown must be used.

See terms and conditions for contrasting upholstery upcharges.

- A) One fabric or leather for seat cushion
 yardage: 5.5 yds. leather: 90.0sq. ft.
- B) One fabric or leather for inside back, outside back and side arm
 yardage: 4.25 yds. leather: 70.0 sq. ft.

SCS Indoor Advantage™ Gold and LEVEL® 2 certified. See terms and conditions for additional environmental information.

Seat Height	Arm Height	W	D	H	Fabric	Leather	Weight	Cubes/Qty
16½"	21½"-29"	66"	31¼"-34¼"	29"	8.5 yds.	144.0'	152 lbs.	68.33'/1
419 mm	546-737 mm	1676 mm	794-870 mm	737 mm	7.8 m	13.4 sqm	69.1 kg	1.93 cu.

COM	COL	1	2	3	4	5	6	7	8	9	10	11
4978	5148	5772	5904	5980	6131	6263	6320	6414	6546	6660	6792	7547

flared front sofa - armless



mirador 8020AL

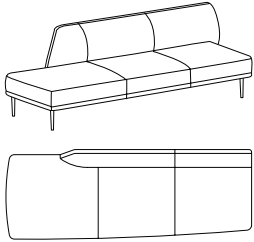

Three-seat armless module
Straight end
Polished aluminum base
Upholstered

All necessary ganging brackets are included and pre-installed

When using a combination of fabrics or leathers, specify the application by designating the appropriate letter, shown below, on the purchase order. Yardage shown must be used.

See terms and conditions for contrasting upholstery upcharges.

- A) One fabric or leather for seat cushion
yardage: 7.5 yds. leather: 122.0 sq. ft.
- B) One fabric or leather for inside back and outside back
yardage: 4.5 yds. leather: 73.0 sq. ft.

SCS Indoor Advantage™ Gold and LEVEL® 2 certified. See terms and conditions for additional environmental information.

Seat Height	Arm Height	W	D	H	Fabric	Leather	Weight	Cubes/Qty
16½"	-	96"	31¼ -34¼"	29"	10.25 yds.	150.0'	200 lbs.	101.65'/1
419 mm	-	2438 mm	794-870 mm	737 mm	9.4 m	14.0 sqm	90.9 kg	2.87 cu.

COM	COL	1	2	3	4	5	6	7	8	9	10	11
5335	5540	6292	6452	6543	6725	6884	6953	7067	7226	7363	7522	8433

mirador 8020BL

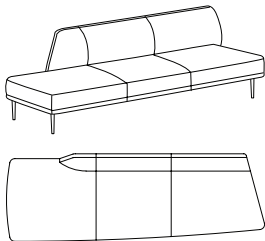

Three-seat armless module
Open angle end
Polished aluminum base
Upholstered

All necessary ganging brackets are included and pre-installed

When using a combination of fabrics or leathers, specify the application by designating the appropriate letter, shown below, on the purchase order. Yardage shown must be used.

See terms and conditions for contrasting upholstery upcharges.

- A) One fabric or leather for seat cushion
yardage: 7.5 yds. leather: 122.0 sq. ft.
- B) One fabric or leather for inside back and outside back
yardage: 4.5 yds. leather: 73.0 sq. ft.

SCS Indoor Advantage™ Gold and LEVEL® 2 certified. See terms and conditions for additional environmental information.

Seat Height	Arm Height	W	D	H	Fabric	Leather	Weight	Cubes/Qty
16½"	-	103"	31¼ -34¼"	29"	10.25 yds.	150.0'	205 lbs.	97.97'/1
419 mm	-	2616 mm	794-870 mm	737 mm	9.4 m	14.0 sqm	93.2 kg	2.77 cu.

COM	COL	1	2	3	4	5	6	7	8	9	10	11
5335	5540	6292	6452	6543	6725	6884	6953	7067	7226	7363	7522	8433

flared front sofa - armless

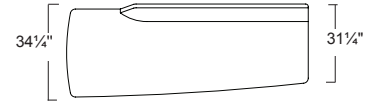

mirador 8020CL

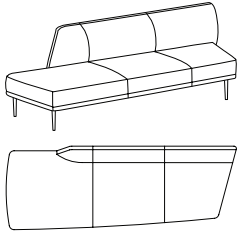

Three-seat armless module
Closed angle end
Polished aluminum base
Upholstered

All necessary ganging brackets are included and pre-installed

When using a combination of fabrics or leathers, specify the application by designating the appropriate letter, shown below, on the purchase order. Yardage shown must be used.

See terms and conditions for contrasting upholstery upcharges.

- A) One fabric or leather for seat cushion
 yardage: 7.5 yds. leather: 122.0 sq. ft.
- B) One fabric or leather for inside back and outside back
 yardage: 4.5 yds. leather: 73.0 sq. ft.

SCS Indoor Advantage™ Gold and LEVEL® 2 certified. See terms and conditions for additional environmental information.

Seat Height	Arm Height	W	D	H	Fabric	Leather	Weight	Cubes/Qty
16½"	-	96"	31¼ -34¼"	29"	10.25 yds.	150.0'	200 lbs.	101.65/1
419 mm	-	2438 mm	794-870 mm	737 mm	9.4 m	14.0 sqm	90.9 kg	2.87 cu.

COM	COL	1	2	3	4	5	6	7	8	9	10	11
5335	5540	6292	6452	6543	6725	6884	6953	7067	7226	7363	7522	8433

mirador 8021AR

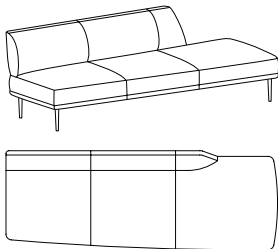

Three-seat armless module
Straight end
Polished aluminum base
Upholstered

All necessary ganging brackets are included and pre-installed

When using a combination of fabrics or leathers, specify the application by designating the appropriate letter, shown below, on the purchase order. Yardage shown must be used.

See terms and conditions for contrasting upholstery upcharges.

- A) One fabric or leather for seat cushion
 yardage: 7.5 yds. leather: 122.0 sq. ft.
- B) One fabric or leather for inside back and outside back
 yardage: 4.5 yds. leather: 73.0 sq. ft.

SCS Indoor Advantage™ Gold and LEVEL® 2 certified. See terms and conditions for additional environmental information.

Seat Height	Arm Height	W	D	H	Fabric	Leather	Weight	Cubes/Qty
16½"	-	96"	31¼ -34¼"	29"	10.25 yds.	150.0'	200 lbs.	101.65/1
419 mm	-	2438 mm	794-870 mm	737 mm	9.4 m	14.0 sqm	90.9 kg	2.87 cu.

COM	COL	1	2	3	4	5	6	7	8	9	10	11
5335	5540	6292	6452	6543	6725	6884	6953	7067	7226	7363	7522	8433



mirador 8021BR

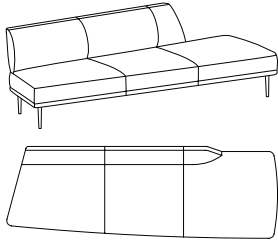

Three-seat armless module
Open angle end
Polished aluminum base
Upholstered

All necessary ganging brackets are included and pre-installed

When using a combination of fabrics or leathers, specify the application by designating the appropriate letter, shown below, on the purchase order. Yardage shown must be used.

See terms and conditions for contrasting upholstery upcharges.

- A) One fabric or leather for seat cushion
 yardage: 7.5 yds. leather: 122.0 q. ft.
- B) One fabric or leather for inside back and outside back
 yardage: 4.5 yds. leather: 73.0 sq. ft.

SCS Indoor Advantage™ Gold and LEVEL® 2 certified. See terms and conditions for additional environmental information.

Seat Height	Arm Height	W	D	H	Fabric	Leather	Weight	Cubes/Qty
16½"	-	103"	31¼ -34¼"	29"	10.25 yds.	150.0'	205 lbs.	97.97/1
419 mm	-	2616 mm	794-870 mm	737 mm	9.4 m	14.0 sqm	93.2 kg	2.77 cu.

COM	COL	1	2	3	4	5	6	7	8	9	10	11
5335	5540	6292	6452	6543	6725	6884	6953	7067	7226	7363	7522	8433

mirador 8021CR

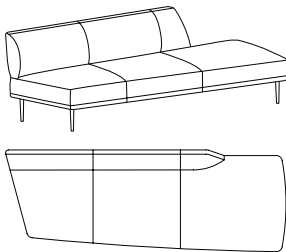

Three-seat armless module
Closed angle end
Polished aluminum base
Upholstered

All necessary ganging brackets are included and pre-installed

When using a combination of fabrics or leathers, specify the application by designating the appropriate letter, shown below, on the purchase order. Yardage shown must be used.

See terms and conditions for contrasting upholstery upcharges.

- A) One fabric or leather for seat cushion
 yardage: 7.5 yds. leather: 122.0 sq. ft.
- B) One fabric or leather for inside back and outside back
 yardage: 4.5 yds. leather: 73.0 sq. ft.

SCS Indoor Advantage™ Gold and LEVEL® 2 certified. See terms and conditions for additional environmental information.

Seat Height	Arm Height	W	D	H	Fabric	Leather	Weight	Cubes/Qty
16½"	-	96"	31¼ -34¼"	29"	10.25 yds.	150.0'	200 lbs.	101.65/1
419 mm	-	2438 mm	794-870 mm	737 mm	9.4 m	14.0 sqm	90.9 kg	2.87 cu.

COM	COL	1	2	3	4	5	6	7	8	9	10	11
5335	5540	6292	6452	6543	6725	6884	6953	7067	7226	7363	7522	8433

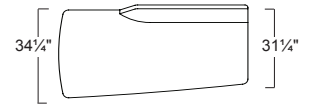

mirador 8022AL

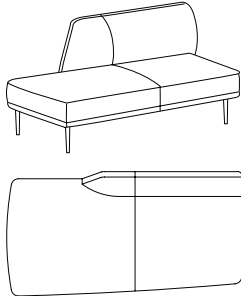

Two-seat armless module
Straight end
Polished aluminum base
Upholstered

All necessary ganging brackets are included and pre-installed

When using a combination of fabrics or leathers, specify the application by designating the appropriate letter, shown below, on the purchase order. Yardage shown must be used.

See terms and conditions for contrasting upholstery upcharges.

- A) One fabric or leather for seat cushion
 yardage: 5.5 yds. leather: 90.0 sq. ft.
- B) One fabric or leather for inside back and outside back
 yardage: 3.0 yds. leather: 50.0 sq. ft.

SCS Indoor Advantage™ Gold and LEVEL® 2 certified. See terms and conditions for additional environmental information.

Seat Height	Arm Height	W	D	H	Fabric	Leather	Weight	Cubes/Qty
16½"	-	66"	31¼ -34¼"	29"	7.5 yds.	100.0'	142 lbs.	68.33'/1
419 mm	-	1676 mm	794-870 mm	737 mm	6.9 m	9.3 sqm	64.5 kg	1.93 cu.

COM	COL	1	2	3	4	5	6	7	8	9	10	11
4444	4594	5144	5261	5328	5461	5578	5628	5711	5828	5928	6044	6711

mirador 8022BL

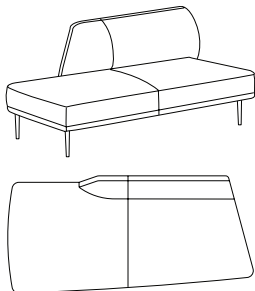

Two-seat armless module
Open angle end
Polished aluminum base
Upholstered

All necessary ganging brackets are included and pre-installed

When using a combination of fabrics or leathers, specify the application by designating the appropriate letter, shown below, on the purchase order. Yardage shown must be used.

See terms and conditions for contrasting upholstery upcharges.

- A) One fabric or leather for seat cushion
 yardage: 5.5 yds. leather: 90.0 sq. ft.
- B) One fabric or leather for inside back and outside back
 yardage: 3.0 yds. leather: 50.0 sq. ft.

SCS Indoor Advantage™ Gold and LEVEL® 2 certified. See terms and conditions for additional environmental information.

Seat Height	Arm Height	W	D	H	Fabric	Leather	Weight	Cubes/Qty
16½"	-	73"	31¼ -34¼"	29"	7.5 yds.	100.0'	147 lbs.	80.67'/1
419 mm	-	1854 mm	794-870 mm	737 mm	6.9 m	9.3 sqm	66.8 kg	2.28cu.

COM	COL	1	2	3	4	5	6	7	8	9	10	11
4444	4594	5144	5261	5328	5461	5578	5628	5711	5828	5928	6044	6711

flared front settee - armless

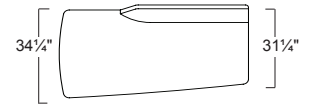

mirador 8022CL

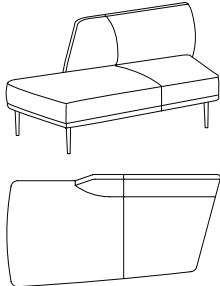

Two-seat armless module
Closed angle end
Polished aluminum base
Upholstered

All necessary ganging brackets are included and pre-installed

When using a combination of fabrics or leathers, specify the application by designating the appropriate letter, shown below, on the purchase order. Yardage shown must be used.

See terms and conditions for contrasting upholstery upcharges.

- A) One fabric or leather for seat cushion
yardage: 5.5 yds. leather: 90.0 sq. ft.
- B) One fabric or leather for inside back and outside back
yardage: 3.0 yds. leather: 50.0 sq. ft.

SCS Indoor Advantage™ Gold and LEVEL® 2 certified. See terms and conditions for additional environmental information.

Seat Height	Arm Height	W	D	H	Fabric	Leather	Weight	Cubes/Qty
16½"	-	66"	31¼ -34¼"	29"	7.5 yds.	100.0'	142 lbs.	68.33'/1
419 mm	-	1676 mm	794-870 mm	29"	6.9 m	9.3 sqm	64.5 kg	1.93 cu.

COM	COL	1	2	3	4	5	6	7	8	9	10	11
4444	4594	5144	5261	5328	5461	5578	5628	5711	5828	5928	6044	6711

mirador 8023AR

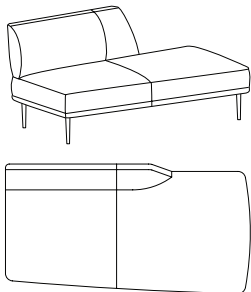

Two-seat armless module
Straight end
Polished aluminum base
Upholstered

All necessary ganging brackets are included and pre-installed

When using a combination of fabrics or leathers, specify the application by designating the appropriate letter, shown below, on the purchase order. Yardage shown must be used.

See terms and conditions for contrasting upholstery upcharges.

- A) One fabric or leather for seat cushion
yardage: 5.5 yds. leather: 90.0 sq. ft.
- B) One fabric or leather for inside back and outside back
yardage: 3.0 yds. leather: 50.0 sq. ft.

SCS Indoor Advantage™ Gold and LEVEL® 2 certified. See terms and conditions for additional environmental information.

Seat Height	Arm Height	W	D	H	Fabric	Leather	Weight	Cubes/Qty
16½"	-	66"	31¼ -34¼"	29"	7.5 yds.	100.0'	142 lbs.	68.33'/1
419 mm	-	1676 mm	794-870 mm	737 mm	6.9 m	9.3 sqm	64.5 kg	1.93 cu.

COM	COL	1	2	3	4	5	6	7	8	9	10	11
4444	4594	5144	5261	5328	5461	5578	5628	5711	5828	5928	6044	6711

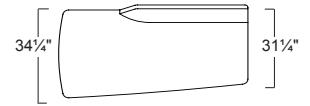

mirador 8023BR

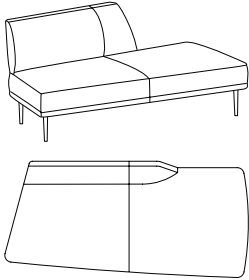

Two-seat armless module
Open angle end
Polished aluminum base
Upholstered

All necessary ganging brackets are included and pre-installed

When using a combination of fabrics or leathers, specify the application by designating the appropriate letter, shown below, on the purchase order. Yardage shown must be used.

See terms and conditions for contrasting upholstery upcharges.

- A) One fabric or leather for seat cushion
 yardage: 5.5 yds. leather: 90.0 sq. ft.
- B) One fabric or leather for inside back and outside back
 yardage: 3.0 yds. leather: 50.0 sq. ft.

SCS Indoor Advantage™ Gold and LEVEL® 2 certified. See terms and conditions for additional environmental information.

Seat Height	Arm Height	W	D	H	Fabric	Leather	Weight	Cubes/Qty
16½"	-	73"	31¼ -34¼"	29"	7.5 yds.	100.0'	147 lbs.	80.67/1
419 mm	-	1854 mm	794-870 mm	737 mm	6.9 m	9.3 sqm	66.8 kg	2.28cu.

COM	COL	1	2	3	4	5	6	7	8	9	10	11
4444	4594	5144	5261	5328	5461	5578	5628	5711	5828	5928	6044	6711

mirador 8023CR

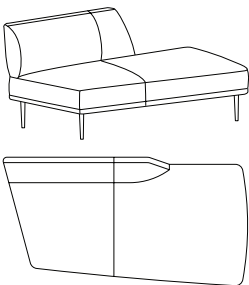

Two-seat armless module
Closed angle end
Polished aluminum base
Upholstered

All necessary ganging brackets are included and pre-installed

When using a combination of fabrics or leathers, specify the application by designating the appropriate letter, shown below, on the purchase order. Yardage shown must be used.

See terms and conditions for contrasting upholstery upcharges.

- A) One fabric or leather for seat cushion
 yardage: 5.5 yds. leather: 90.0 sq. ft.
- B) One fabric or leather for inside back and outside back
 yardage: 3.0 yds. leather: 50.0 sq. ft.

SCS Indoor Advantage™ Gold and LEVEL® 2 certified. See terms and conditions for additional environmental information.

Seat Height	Arm Height	W	D	H	Fabric	Leather	Weight	Cubes/Qty
16½"	-	66"	31¼ -34¼"	29"	7.5 yds.	100.0'	142 lbs.	68.33/1
419 mm	-	1676 mm	794-870 mm	737 mm	6.9 m	9.3 sqm	64.5 kg	1.93 cu.

COM	COL	1	2	3	4	5	6	7	8	9	10	11
4444	4594	5144	5261	5328	5461	5578	5628	5711	5828	5928	6044	6711

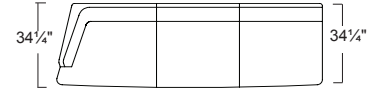

mirador 8016 BL

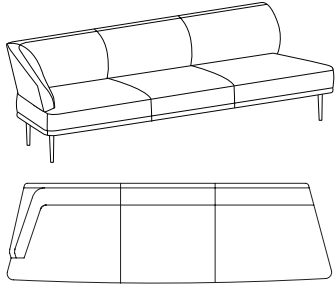

Three-seat module
Left arm facing
Open angle end
Polished aluminum base
Upholstered

All necessary ganging brackets are included and pre-installed

When using a combination of fabrics or leathers, specify the application by designating the appropriate letter, shown below, on the purchase order. Yardage shown must be used.

See terms and conditions for contrasting upholstery upcharges.

- A) One fabric or leather for seat cushion
 yardage: 7.5 yds. leather: 122.0 sq. ft.
- B) One fabric or leather for inside back, outside back and side arm
 yardage: 5.75 yds. leather: 95.0 sq. ft.

SCS Indoor Advantage™ Gold and LEVEL® 2 certified. See terms and conditions for additional environmental information.

Seat Height	Arm Height	W	D	H	Fabric	Leather	Weight	Cubes/Qty
16½"	21½ -29"	103"	31¼"	29"	11.2 yds.	168.0'	225 lbs.	97.97'/1
419 mm	546-737 mm	2616 mm	794 mm	737 mm	10.3 m	15.6 sqm	102.3 kg	2.77 cu.

COM	COL	1	2	3	4	5	6	7	8	9	10	11
6219	6439	7246	7417	7515	7711	7882	7955	8077	8248	8395	8566	9544

mirador 8016AL

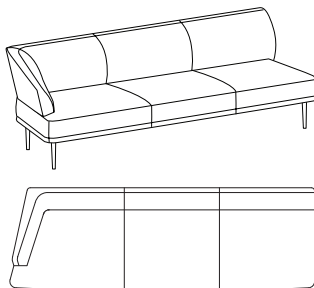

Three-seat module
Left arm facing
Straight end
Polished aluminum base
Upholstered

All necessary ganging brackets are included and pre-installed

When using a combination of fabrics or leathers, specify the application by designating the appropriate letter, shown below, on the purchase order. Yardage shown must be used.

See terms and conditions for contrasting upholstery upcharges.

- A) One fabric or leather for seat cushion
 yardage: 7.5 yds. leather: 122.0 sq. ft.
- B) One fabric or leather for inside back, outside back and side arm
 yardage: 5.75 yds. leather: 95.0 sq. ft.

SCS Indoor Advantage™ Gold and LEVEL® 2 certified. See terms and conditions for additional environmental information.

Seat Height	Arm Height	W	D	H	Fabric	Leather	Weight	Cubes/Qty
16½"	21½ -29"	96"	31¼"	29"	11.2 yds.	168.0'	220 lbs.	101.65'/1
419 mm	546-737 mm	2438 mm	794 mm	737 mm	10.3 m	15.6 sqm	100.0 kg	2.87 cu.

COM	COL	1	2	3	4	5	6	7	8	9	10	11
6219	6439	7246	7417	7515	7711	7882	7955	8077	8248	8395	8566	9544

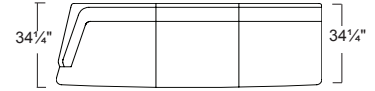

mirador 8016CL

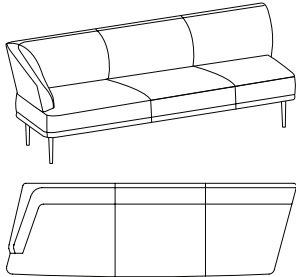

Three-seat module
Left arm facing
Closed angle end
Polished aluminum base
Upholstered

All necessary ganging brackets are included and pre-installed

When using a combination of fabrics or leathers, specify the application by designating the appropriate letter, shown below, on the purchase order. Yardage shown must be used.

See terms and conditions for contrasting upholstery upcharges.

- A) One fabric or leather for seat cushion
 yardage: 7.5 yds. leather: 122.0 sq. ft.
- B) One fabric or leather for inside back, outside back and side arm
 yardage: 5.75 yds. leather: 95.0 sq. ft.

SCS Indoor Advantage™ Gold and LEVEL® 2 certified. See terms and conditions for additional environmental information.

Seat Height	Arm Height	W	D	H	Fabric	Leather	Weight	Cubes/Qty
16½"	21½ -29"	96"	31¼"	29"	11.2 yds.	168.0'	220 lbs.	101.65/1
419 mm	546-737 mm	2438 mm	794 mm	737 mm	10.3 m	15.6 sqm	100.0 kg	2.87 cu.

COM	COL	1	2	3	4	5	6	7	8	9	10	11
6219	6439	7246	7417	7515	7711	7882	7955	8077	8248	8395	8566	9544

mirador 8017AR

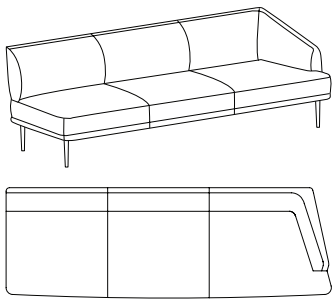

Three-seat module
Right arm facing
Straight end
Polished aluminum base
Upholstered

All necessary ganging brackets are included and pre-installed

When using a combination of fabrics or leathers, specify the application by designating the appropriate letter, shown below, on the purchase order. Yardage shown must be used.

See terms and conditions for contrasting upholstery upcharges.

- A) One fabric or leather for seat cushion
 yardage: 7.5 yds. leather: 122.0 sq. ft.
- B) One fabric or leather for inside back, outside back and side arm
 yardage: 5.75 yds. leather: 95.0 sq. ft.

SCS Indoor Advantage™ Gold and LEVEL® 2 certified. See terms and conditions for additional environmental information.

Seat Height	Arm Height	W	D	H	Fabric	Leather	Weight	Cubes/Qty
16½"	21½ -29"	96"	31¼"	29"	11.2 yds.	168.0'	220 lbs.	101.65/1
419 mm	546-737 mm	2438 mm	794 mm	737 mm	10.3 m	15.6 sqm	100.0 kg	2.87 cu.

COM	COL	1	2	3	4	5	6	7	8	9	10	11
6219	6439	7246	7417	7515	7711	7882	7955	8077	8248	8395	8566	9544

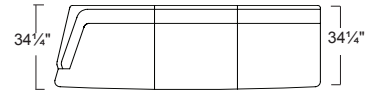

mirador 8017BR

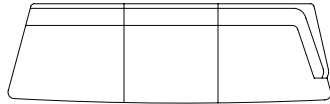
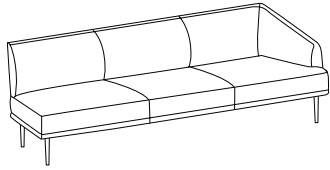

Three-seat module
Right arm facing
Open angle end
Polished aluminum base
Upholstered

All necessary ganging brackets are included and pre-installed

When using a combination of fabrics or leathers, specify the application by designating the appropriate letter, shown below, on the purchase order. Yardage shown must be used.

See terms and conditions for contrasting upholstery upcharges.

- A) One fabric or leather for seat cushion
 yardage: 7.5 yds. leather: 122.0 sq. ft.
- B) One fabric or leather for inside back, outside back and side arm
 yardage: 5.75 yds. leather: 95.0 sq. ft.

SCS Indoor Advantage™ Gold and LEVEL® 2 certified. See terms and conditions for additional environmental information.

Seat Height	Arm Height	W	D	H	Fabric	Leather	Weight	Cubes/Qty
16½"	21½"-29"	103"	31¼"	29"	11.2 yds.	168.0'	225 lbs.	97.97'/1
419 mm	546-737 mm	2616 mm	794 mm	737 mm	10.3 m	15.6 sqm	102.3 kg	2.77 cu.

COM	COL	1	2	3	4	5	6	7	8	9	10	11
6219	6439	7246	7417	7515	7711	7882	7955	8077	8248	8395	8566	9544

mirador 8017CR

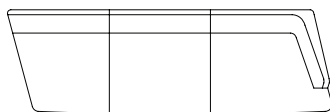
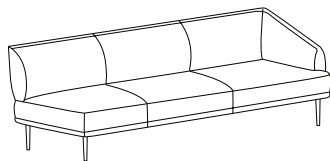

Three-seat module
Right arm facing
Closed angle end
Polished aluminum base
Upholstered

All necessary ganging brackets are included and pre-installed

When using a combination of fabrics or leathers, specify the application by designating the appropriate letter, shown below, on the purchase order. Yardage shown must be used.

See terms and conditions for contrasting upholstery upcharges.

- A) One fabric or leather for seat cushion
 yardage: 7.5 yds. leather: 122.0 sq. ft.
- B) One fabric or leather for inside back, outside back and side arm
 yardage: 5.75 yds. leather: 95.0 sq. ft.

SCS Indoor Advantage™ Gold and LEVEL® 2 certified. See terms and conditions for additional environmental information.

Seat Height	Arm Height	W	D	H	Fabric	Leather	Weight	Cubes/Qty
16½"	21½"-29"	96"	31¼"	29"	11.2 yds.	168.0'	220 lbs.	101.65'/1
419 mm	546-737 mm	2438 mm	794 mm	737 mm	10.3 m	15.6 sqm	100.0 kg	2.87 cu.

COM	COL	1	2	3	4	5	6	7	8	9	10	11
6219	6439	7246	7417	7515	7711	7882	7955	8077	8248	8395	8566	9544

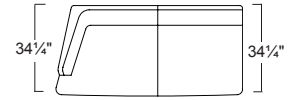

mirador 8018AL

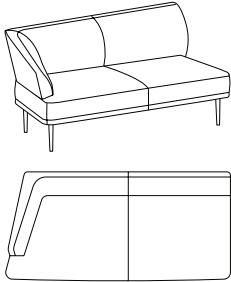

Two-seat module
Left arm facing
Straight end
Polished aluminum base
Upholstered

All necessary ganging brackets are included and pre-installed

When using a combination of fabrics or leathers, specify the application by designating the appropriate letter, shown below, on the purchase order. Yardage shown must be used.

See terms and conditions for contrasting upholstery upcharges.

- A) One fabric or leather for seat cushion
 yardage: 5.5 yds. leather: 90.0 sq. ft.
- B) One fabric or leather for inside back, outside back and side arm
 yardage: 4.25 yds. leather: 70.0 sq. ft.

SCS Indoor Advantage™ Gold and LEVEL® 2 certified. See terms and conditions for additional environmental information.

Seat Height	Arm Height	W	D	H	Fabric	Leather	Weight	Cubes/Qty
16½"	21½ -29"	66"	31¼"	29"	8.5 yds.	144.0'	152 lbs.	68.33'/1
419 mm	546-737 mm	1676 mm	794 mm	737 mm	7.8 m	13.4 sqm	69.1 kg	1.93 cu.

COM	COL	1	2	3	4	5	6	7	8	9	10	11
4978	5148	5772	5904	5980	6131	6263	6320	6414	6546	6660	6792	7547

mirador 8018BL

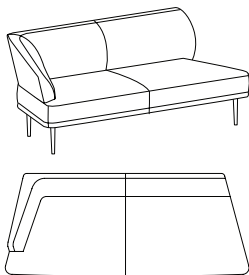

Two-seat module
Left arm facing
Open angle end
Polished aluminum base
Upholstered

All necessary ganging brackets are included and pre-installed

When using a combination of fabrics or leathers, specify the application by designating the appropriate letter, shown below, on the purchase order. Yardage shown must be used.

See terms and conditions for contrasting upholstery upcharges.

- A) One fabric or leather for seat cushion
 yardage: 5.5 yds. leather: 90.0 sq. ft.
- B) One fabric or leather for inside back, outside back and side arm
 yardage: 4.25 yds. leather: 70.0 sq. ft.

SCS Indoor Advantage™ Gold and LEVEL® 2 certified. See terms and conditions for additional environmental information.

Seat Height	Arm Height	W	D	H	Fabric	Leather	Weight	Cubes/Qty
16½"	21½ -29"	73"	31¼"	29"	8.5 yds.	144.0'	157 lbs.	80.67'/1
419 mm	546-737 mm	1854 mm	794 mm	737 mm	7.8 m	13.4 sqm	71.4 kg	2.28 cu.

COM	COL	1	2	3	4	5	6	7	8	9	10	11
4978	5148	5772	5904	5980	6131	6263	6320	6414	6546	6660	6792	7547

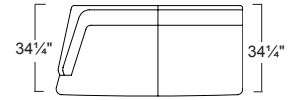

mirador 8018CL

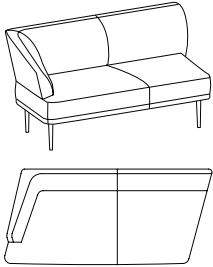

Two-seat module
Left arm facing
Closed angle end
Polished aluminum base
Upholstered

All necessary ganging brackets are included and pre-installed

When using a combination of fabrics or leathers, specify the application by designating the appropriate letter, shown below, on the purchase order. Yardage shown must be used.

See terms and conditions for contrasting upholstery upcharges.

- A) One fabric or leather for seat cushion
 yardage: 5.5 yds. leather: 90.0 sq. ft.
- B) One fabric or leather for inside back, outside back and side arm
 yardage: 4.25 yds. leather: 70.0 sq. ft.

SCS Indoor Advantage™ Gold and LEVEL® 2 certified. See terms and conditions for additional environmental information.

Seat Height	Arm Height	W	D	H	Fabric	Leather	Weight	Cubes/Qty
16½"	21½ -29"	66"	31¼"	29"	8.5 yds.	144.0'	152 lbs.	68.33'/1
419 mm	546-737 mm	1676 mm	794 mm	737 mm	7.8 m	13.4 sqm	69.1 kg	1.93 cu.

COM	COL	1	2	3	4	5	6	7	8	9	10	11
4978	5148	5772	5904	5980	6131	6263	6320	6414	6546	6660	6792	7547

mirador 8019AR

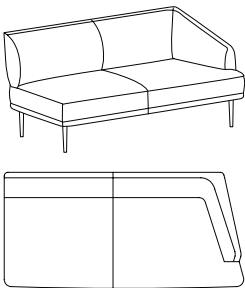

Two-seat module
Right arm facing
Straight end
Polished aluminum base
Upholstered

All necessary ganging brackets are included and pre-installed

When using a combination of fabrics or leathers, specify the application by designating the appropriate letter, shown below, on the purchase order. Yardage shown must be used.

See terms and conditions for contrasting upholstery upcharges.

- A) One fabric or leather for seat cushion
 yardage: 5.5 yds. leather: 90.0 sq. ft.
- B) One fabric or leather for inside back, outside back and side arm
 yardage: 4.25 yds. leather: 70.0 sq. ft.

SCS Indoor Advantage™ Gold and LEVEL® 2 certified. See terms and conditions for additional environmental information.

Seat Height	Arm Height	W	D	H	Fabric	Leather	Weight	Cubes/Qty
16½"	21½ -29"	66"	31¼"	29"	8.5 yds.	144.0'	152 lbs.	68.33'/1
419 mm	546-737 mm	1676 mm	794 mm	737 mm	7.8 m	13.4 sqm	69.1 kg	1.93 cu.

COM	COL	1	2	3	4	5	6	7	8	9	10	11
4978	5148	5772	5904	5980	6131	6263	6320	6414	6546	6660	6792	7547

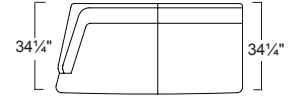

mirador 8019BR

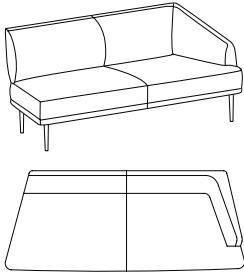

Two-seat module
Right arm facing
Open angle end
Polished aluminum base
Upholstered

All necessary ganging brackets are included and pre-installed

When using a combination of fabrics or leathers, specify the application by designating the appropriate letter, shown below, on the purchase order. Yardage shown must be used.

See terms and conditions for contrasting upholstery upcharges.

- A) One fabric or leather for seat cushion
 yardage: 5.5 yds. leather: 90.0 sq. ft.
- B) One fabric or leather for inside back, outside back and side arm
 yardage: 4.25 yds. leather: 70.0 sq. ft.

SCS Indoor Advantage™ Gold and LEVEL® 2 certified. See terms and conditions for additional environmental information.

Seat Height	Arm Height	W	D	H	Fabric	Leather	Weight	Cubes/Qty
16½"	21½"-29"	73"	31¼"	29"	8.5 yds.	144.0'	157 lbs.	80.67'/1
419 mm	546-737 mm	1854 mm	794 mm	737 mm	7.8 m	13.4 sqm	71.4 kg	2.28 cu.

COM	COL	1	2	3	4	5	6	7	8	9	10	11
4978	5148	5772	5904	5980	6131	6263	6320	6414	6546	6660	6792	7547

mirador 8019CR

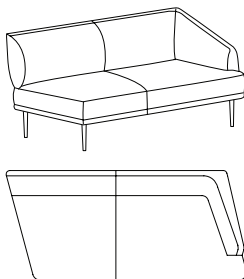

Two-seat module
Right arm facing
Closed angle end
Polished aluminum base
Upholstered

All necessary ganging brackets are included and pre-installed

When using a combination of fabrics or leathers, specify the application by designating the appropriate letter, shown below, on the purchase order. Yardage shown must be used.

See terms and conditions for contrasting upholstery upcharges.

- A) One fabric or leather for seat cushion
 yardage: 5.5 yds. leather: 90.0 sq. ft.
- B) One fabric or leather for inside back, outside back and side arm
 yardage: 4.25 yds. leather: 70.0 sq. ft.

SCS Indoor Advantage™ Gold and LEVEL® 2 certified. See terms and conditions for additional environmental information.

Seat Height	Arm Height	W	D	H	Fabric	Leather	Weight	Cubes/Qty
16½"	21½"-29"	66"	31¼"	29"	8.5 yds.	144.0'	152 lbs.	68.33'/1
419 mm	546-737 mm	1676 mm	794 mm	737 mm	7.8 m	13.4 sqm	69.1 kg	1.93 cu.

COM	COL	1	2	3	4	5	6	7	8	9	10	11
4978	5148	5772	5904	5980	6131	6263	6320	6414	6546	6660	6792	7547

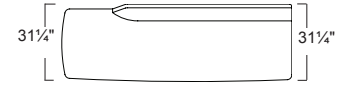

mirador 8026AL

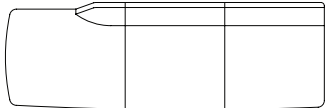
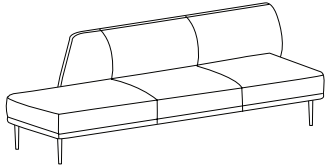

Three-seat armless
Straight end
Polished aluminum base
Upholstered

All necessary ganging brackets are included and pre-installed

When using a combination of fabrics or leathers, specify the application by designating the appropriate letter, shown below, on the purchase order. Yardage shown must be used.

See terms and conditions for contrasting upholstery upcharges.

- A) One fabric or leather for seat cushion
 yardage: 7.5 yds. leather: 122.0 sq. ft.
- B) One fabric or leather for inside back and outside back
 yardage: 4.5 yds. leather: 73.0 sq. ft.

CS Indoor Advantage™ Gold and LEVEL® 2 certified. See terms and conditions for additional environmental information.

Seat Height	Arm Height	W	D	H	Fabric	Leather	Weight	Cubes/Qty
16½"	-	96"	31¼"	29"	10.2 yds.	150.0'	201 lbs.	101.65'/1
419 mm	-	2438 mm	794 mm	737 mm	9.4 m	14.0 sqm	91.4 kg	2.87 cu.

COM	COL	1	2	3	4	5	6	7	8	9	10	11
5335	5540	6292	6452	6543	6725	6884	6953	7067	7226	7363	7522	8433

mirador 8026BL

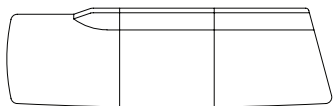
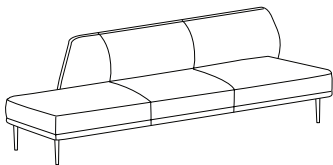

Three-seat armless
Open angle end
Polished aluminum base
Upholstered

All necessary ganging brackets are included and pre-installed

When using a combination of fabrics or leathers, specify the application by designating the appropriate letter, shown below, on the purchase order. Yardage shown must be used.

See terms and conditions for contrasting upholstery upcharges.

- A) One fabric or leather for seat cushion
 yardage: 7.5 yds. leather: 122.0 sq. ft.
- B) One fabric or leather for inside back and outside back
 yardage: 4.5 yds. leather: 73.0 sq. ft.

SCS Indoor Advantage™ Gold and LEVEL® 2 certified. See terms and conditions for additional environmental information.

Seat Height	Arm Height	W	D	H	Fabric	Leather	Weight	Cubes/Qty
16½"	-	103"	31¼"	29"	10.2 yds.	150.0'	206 lbs.	97.97'/1
419 mm	-	2616 mm	794 mm	737 mm	9.4 m	14.0 sqm	93.6 kg	2.77 cu.

COM	COL	1	2	3	4	5	6	7	8	9	10	11
5335	5540	6292	6452	6543	6725	6884	6953	7067	7226	7363	7522	8433

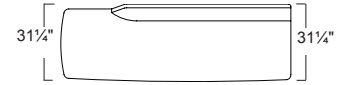

mirador 8026CL

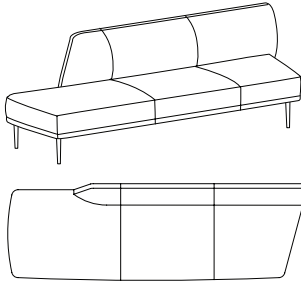

**Three-seat armless
Closed angle end
Polished aluminum base
Upholstered**

All necessary ganging brackets are included and pre-installed

When using a combination of fabrics or leathers, specify the application by designating the appropriate letter, shown below, on the purchase order. Yardage shown must be used.

See terms and conditions for contrasting upholstery upcharges.

- A) One fabric or leather for seat cushion
yardage: 7.5 yds. leather: 122.0 sq. ft.
- B) One fabric or leather for inside back and outside back
yardage: 4.5 yds. leather: 73.0 sq. ft.

SCS Indoor Advantage™ Gold and LEVEL® 2 certified. See terms and conditions for additional environmental information.

Seat Height	Arm Height	W	D	H	Fabric	Leather	Weight	Cubes/Qty
16½"	-	96"	31¼"	29"	10.2 yds.	150.0'	201 lbs.	101.65/1
419 mm	-	2438 mm	794 mm	737 mm	9.4 m	14.0 sqm	91.4 kg	101.65/1

COM	COL	1	2	3	4	5	6	7	8	9	10	11
5335	5540	6292	6452	6543	6725	6884	6953	7067	7226	7363	7522	8433

mirador 8027AR

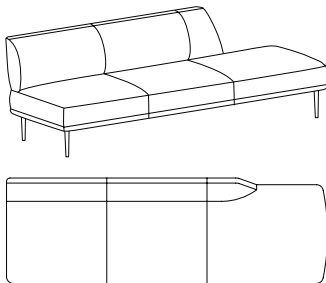

**Three-seat armless
Straight end
Polished aluminum base
Upholstered**

All necessary ganging brackets are included and pre-installed

When using a combination of fabrics or leathers, specify the application by designating the appropriate letter, shown below, on the purchase order. Yardage shown must be used.

See terms and conditions for contrasting upholstery upcharges.

- A) One fabric or leather for seat cushion
yardage: 7.5 yds. leather: 122.0 sq. ft.
- B) One fabric or leather for inside back and outside back
yardage: 4.5 yds. leather: 73.0 sq. ft.

SCS Indoor Advantage™ Gold and LEVEL® 2 certified. See terms and conditions for additional environmental information.

Seat Height	Arm Height	W	D	H	Fabric	Leather	Weight	Cubes/Qty
16½"	-	96"	31¼"	29"	10.2 yds.	150.0'	201 lbs.	101.65/1
419 mm	-	2438 mm	794 mm	737 mm	9.4 m	14.0 sqm	91.4 kg	2.87 cu.

COM	COL	1	2	3	4	5	6	7	8	9	10	11
5335	5540	6292	6452	6543	6725	6884	6953	7067	7226	7363	7522	8433



mirador 8027BR

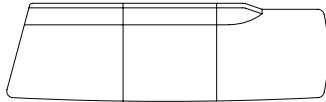
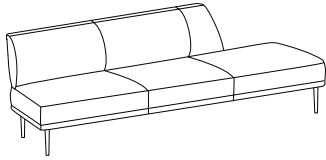

Three-seat armless
Open angle end
Polished aluminum base
Upholstered

All necessary ganging brackets are included and pre-installed

When using a combination of fabrics or leathers, specify the application by designating the appropriate letter, shown below, on the purchase order. Yardage shown must be used.

See terms and conditions for contrasting upholstery upcharges.

- A) One fabric or leather for seat cushion
 yardage: 7.5 yds. leather: 122.0 sq. ft.
- B) One fabric or leather for inside back and outside back
 yardage: 4.5 yds. leather: 73.0 sq. ft.

SCS Indoor Advantage™ Gold and LEVEL® 2 certified. See terms and conditions for additional environmental information.

Seat Height	Arm Height	W	D	H	Fabric	Leather	Weight	Cubes/Qty
16½"	-	103"	31¼"	29"	10.2 yds.	150.0'	206 lbs.	97.97'/1
419 mm	-	2616 mm	794 mm	737 mm	9.4 m	14.0 sqm	93.6 kg	97.97'/1

COM	COL	1	2	3	4	5	6	7	8	9	10	11
5335	5540	6292	6452	6543	6725	6884	6953	7067	7226	7363	7522	8433

mirador 8027CR

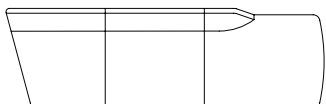
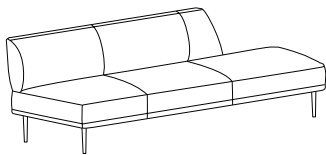

Three-seat armless
Closed angle end
Polished aluminum base
Upholstered

All necessary ganging brackets are included and pre-installed

When using a combination of fabrics or leathers, specify the application by designating the appropriate letter, shown below, on the purchase order. Yardage shown must be used.

See terms and conditions for contrasting upholstery upcharges.

- A) One fabric or leather for seat cushion
 yardage: 7.5 yds. leather: 122.0 sq. ft.
- B) One fabric or leather for inside back and outside back
 yardage: 4.5 yds. leather: 73.0 sq. ft.

SCS Indoor Advantage™ Gold and LEVEL® 2 certified. See terms and conditions for additional environmental information.

Seat Height	Arm Height	W	D	H	Fabric	Leather	Weight	Cubes/Qty
16½"	-	96"	31¼"	29"	10.2 yds.	150.0'	201 lbs.	101.65'/1
419 mm	-	2438 mm	794 mm	737 mm	9.4 m	14.0 sqm	91.4 kg	2.87 cu.

COM	COL	1	2	3	4	5	6	7	8	9	10	11
5335	5540	6292	6452	6543	6725	6884	6953	7067	7226	7363	7522	8433

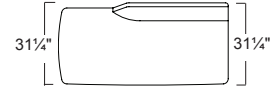

mirador 8028AL

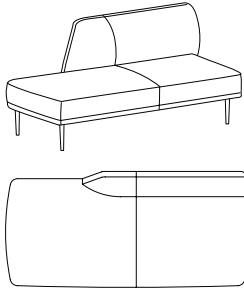

Two-seat armless
Straight end
Polished aluminum base
Upholstered

All necessary ganging brackets are included and pre-installed

When using a combination of fabrics or leathers, specify the application by designating the appropriate letter, shown below, on the purchase order. Yardage shown must be used.

See terms and conditions for contrasting upholstery upcharges.

- A) One fabric or leather for seat cushion
 yardage: 5.5 yds. leather: 90.0 sq. ft.
- B) One fabric or leather for inside back and outside back
 yardage: 3.0 yds. leather: 50.0 sq. ft.

SCS Indoor Advantage™ Gold and LEVEL® 2 certified. See terms and conditions for additional environmental information.

Seat Height	Arm Height	W	D	H	Fabric	Leather	Weight	Cubes/Qty
16½"	-	66"	31¼"	29"	7.5 yds.	100.0'	146 lbs.	68.33'/1
419 mm	-	66"	31¼"	29"	6.9 m	9.3 sqm	66.4 kg	1.93 cu.

COM	COL	1	2	3	4	5	6	7	8	9	10	11
4444	4594	5144	5261	5328	5461	5578	5628	5711	5828	5928	6044	6711

mirador 8028BL

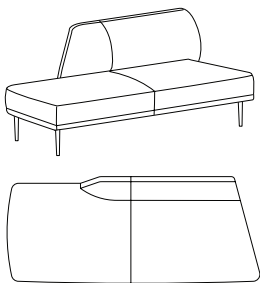

Two-seat armless
Open angle end
Polished aluminum base
Upholstered

All necessary ganging brackets are included and pre-installed

When using a combination of fabrics or leathers, specify the application by designating the appropriate letter, shown below, on the purchase order. Yardage shown must be used.

See terms and conditions for contrasting upholstery upcharges.

- A) One fabric or leather for seat cushion
 yardage: 5.5 yds. leather: 90.0 sq. ft.
- B) One fabric or leather for inside back and outside back
 yardage: 3.0 yds. leather: 50.0 sq. ft.

SCS Indoor Advantage™ Gold and LEVEL® 2 certified. See terms and conditions for additional environmental information.

Seat Height	Arm Height	W	D	H	Fabric	Leather	Weight	Cubes/Qty
16½"	-	73"	31¼"	29"	7.5 yds.	100.0'	151 lbs.	80.67'/1
419 mm	-	1854 mm	794 mm	737 mm	6.9 m	9.3 sqm	68.6 kg	2.28 cu.

COM	COL	1	2	3	4	5	6	7	8	9	10	11
4444	4594	5144	5261	5328	5461	5578	5628	5711	5828	5928	6044	6711

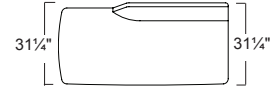

mirador 8028CL

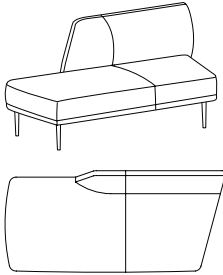

**Two-seat armless
Closed angle end
Polished aluminum base
Upholstered**

All necessary ganging brackets are included and pre-installed

When using a combination of fabrics or leathers, specify the application by designating the appropriate letter, shown below, on the purchase order. Yardage shown must be used.

See terms and conditions for contrasting upholstery upcharges.

- A) One fabric or leather for seat cushion
yardage: 5.5 yds. leather: 90.0 sq. ft.
- B) One fabric or leather for inside back and outside back
yardage: 3.0 yds. leather: 50.0 sq. ft.

SCS Indoor Advantage™ Gold and LEVEL® 2 certified. See terms and conditions for additional environmental information.

Seat Height	Arm Height	W	D	H	Fabric	Leather	Weight	Cubes/Qty
16½"	-	66"	31¼"	29"	7.5 yds.	100.0'	146 lbs.	68.33'/1
419 mm	-	1676 mm	794 mm	737 mm	6.9 m	9.3 sqm	66.4 kg	1.93 cu.

COM	COL	1	2	3	4	5	6	7	8	9	10	11
4444	4594	5144	5261	5328	5461	5578	5628	5711	5828	5928	6044	6711

mirador 8029AR

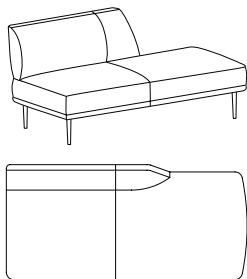

**Two-seat armless
Straight end
Polished aluminum base
Upholstered**

All necessary ganging brackets are included and pre-installed

When using a combination of fabrics or leathers, specify the application by designating the appropriate letter, shown below, on the purchase order. Yardage shown must be used.

See terms and conditions for contrasting upholstery upcharges.

- A) One fabric or leather for seat cushion
yardage: 5.5 yds. leather: 90.0 sq. ft.
- B) One fabric or leather for inside back and outside back
yardage: 3.0 yds. leather: 50.0sq. ft.

SCS Indoor Advantage™ Gold and LEVEL® 2 certified. See terms and conditions for additional environmental information.

Seat Height	Arm Height	W	D	H	Fabric	Leather	Weight	Cubes/Qty
16½"	-	66"	31¼"	29"	7.5 yds.	100.0'	146 lbs.	68.33'/1
419 mm	-	1676 mm	794 mm	737 mm	6.9 m	9.3 sqm	66.4 kg	1.93 cu.

COM	COL	1	2	3	4	5	6	7	8	9	10	11
4444	4594	5144	5261	5328	5461	5578	5628	5711	5828	5928	6044	6711

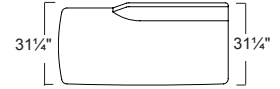

mirador 8029BR

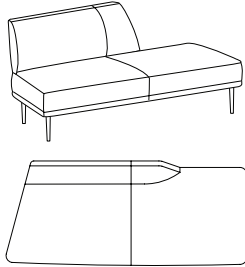

Two-seat armless
Open angle end
Polished aluminum base
Upholstered

All necessary ganging brackets are included and pre-installed

When using a combination of fabrics or leathers, specify the application by designating the appropriate letter, shown below, on the purchase order. Yardage shown must be used.

See terms and conditions for contrasting upholstery upcharges.

- A) One fabric or leather for seat cushion
 yardage: 5.5 yds. leather: 90.0 sq. ft.
- B) One fabric or leather for inside back and outside back
 yardage: 3.0 yds. leather: 50.0 sq. ft.

SCS Indoor Advantage™ Gold and LEVEL® 2 certified. See terms and conditions for additional environmental information.

Seat Height	Arm Height	W	D	H	Fabric	Leather	Weight	Cubes/Qty
16½"	-	73"	31¼"	29"	7.5 yds.	100.0'	151 lbs.	80.67/1
419 mm	-	1854 mm	794 mm	737 mm	6.9 m	9.3 sqm	68.6 kg	2.28 cu.

COM	COL	1	2	3	4	5	6	7	8	9	10	11
4444	4594	5144	5261	5328	5461	5578	5628	5711	5828	5928	6044	6711

mirador 8029CR

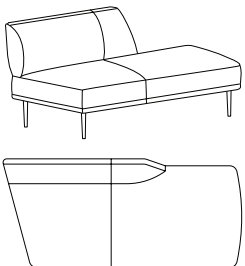

Two-seat armless
Closed angle end
Polished aluminum base
Upholstered

All necessary ganging brackets are included and pre-installed

When using a combination of fabrics or leathers, specify the application by designating the appropriate letter, shown below, on the purchase order. Yardage shown must be used.

See terms and conditions for contrasting upholstery upcharges.

- A) One fabric or leather for seat cushion
 yardage: 5.5 yds. leather: 90.0 sq. ft.
- B) One fabric or leather for inside back and outside back
 yardage: 3.0 yds. leather: 50.0 sq. ft.

SCS Indoor Advantage™ Gold and LEVEL® 2 certified. See terms and conditions for additional environmental information.

Seat Height	Arm Height	W	D	H	Fabric	Leather	Weight	Cubes/Qty
16½"	-	66"	31¼"	29"	7.5 yds.	100.0'	146 lbs.	68.33/1
419 mm	-	1676 mm	794 mm	737 mm	6.9 m	9.3 sqm	66.4 kg	1.93 cu.

COM	COL	1	2	3	4	5	6	7	8	9	10	11
4444	4594	5144	5261	5328	5461	5578	5628	5711	5828	5928	6044	6711

connecting module

mirador 8030A

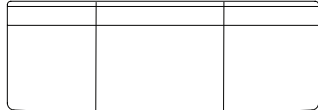
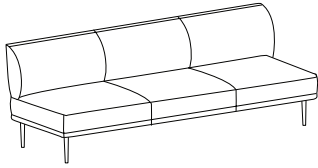

Three-seat armless
Straight ends
Polished aluminum base
Upholstered

All necessary ganging brackets are included and pre-installed

When using a combination of fabrics or leathers, specify the application by designating the appropriate letter, shown below, on the purchase order. Yardage shown must be used.

See terms and conditions for contrasting upholstery upcharges.

- A) One fabric or leather for seat cushion
yardage: 7.5 yds. leather: 122.0 sq. ft.
- B) One fabric or leather for inside back and outside back
yardage: 5.5 yds. leather: 90.0 sq. ft.

SCS Indoor Advantage™ Gold and LEVEL® 2 certified. See terms and conditions for additional environmental information.

Seat Height	Arm Height	W	D	H	Fabric	Leather	Weight	Cubes/Qty
16½"	-	90"	31¼"	29"	11.0 yds.	160.0'	210 lbs.	101.65'/1
419 mm	-	2280 mm	794 mm	737 mm	10.0 m	14.9 sqm	95.5 kg	2.87 cu.

COM	COL	1	2	3	4	5	6	7	8	9	10	11
5156	5376	6183	6354	6452	6648	6819	6892	7014	7185	7332	7503	8481

mirador 8030B

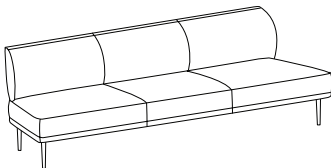

Three-seat armless
Open angle ends
Polished aluminum base
Upholstered

All necessary ganging brackets are included and pre-installed

When using a combination of fabrics or leathers, specify the application by designating the appropriate letter, shown below, on the purchase order. Yardage shown must be used.

See terms and conditions for contrasting upholstery upcharges.

- A) One fabric or leather for seat cushion
yardage: 7.5 yds. leather: 122.0 sq. ft.
- B) One fabric or leather for inside back and outside back
yardage: 5.5 yds. leather: 90.0 sq. ft.

SCS Indoor Advantage™ Gold and LEVEL® 2 certified. See terms and conditions for additional environmental information.

Seat Height	Arm Height	W	D	H	Fabric	Leather	Weight	Cubes/Qty
16½"	-	103"	31¼"	29"	11.0 yds.	160.0'	220 lbs.	97.97'/1
419 mm	-	2616 mm	794 mm	737 mm	10.0 m	14.9 sqm	100.0 kg	2.77 cu.

COM	COL	1	2	3	4	5	6	7	8	9	10	11
5156	5376	6183	6354	6452	6648	6819	6892	7014	7185	7332	7503	8481

connecting module

mirador 8030C

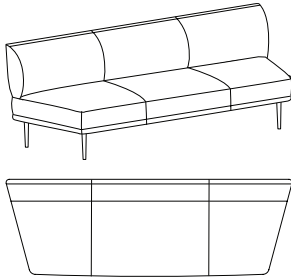

Three-seat armless
Closed angle ends
Polished aluminum base
Upholstered

All necessary ganging brackets are included and pre-installed

When using a combination of fabrics or leathers, specify the application by designating the appropriate letter, shown below, on the purchase order. Yardage shown must be used.

See terms and conditions for contrasting upholstery upcharges.

- A) One fabric or leather for seat cushion
yardage: 7.5 yds. leather: 122.0 sq. ft.
- B) One fabric or leather for inside back and outside back
yardage: 5.5 yds. leather: 90.0 sq. ft.

SCS Indoor Advantage™ Gold and LEVEL® 2 certified. See terms and conditions for additional environmental information.

Seat Height	Arm Height	W	D	H	Fabric	Leather	Weight	Cubes/Qty
16½"	-	90"	31¼"	29"	11.0 yds.	160.0'	200 lbs.	101.65'/1
419 mm	-	2286 mm	794 mm	737 mm	10.0 m	14.9 sqm	90.9 kg	2.87 cu.

COM	COL	1	2	3	4	5	6	7	8	9	10	11
5156	5376	6183	6354	6452	6648	6819	6892	7014	7185	7332	7503	8481

mirador 8031A

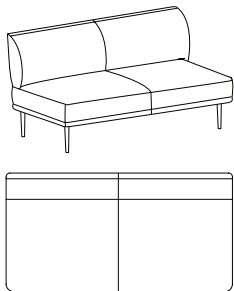

Two-seat armless
Straight ends
Polished aluminum base
Upholstered

All necessary ganging brackets are included and pre-installed

When using a combination of fabrics or leathers, specify the application by designating the appropriate letter, shown below, on the purchase order. Yardage shown must be used.

See terms and conditions for contrasting upholstery upcharges.

- A) One fabric or leather for seat cushion
yardage: 5.5 yds. leather: 90.0 sq. ft.
- B) One fabric or leather for inside back and outside back
yardage: 4.0 yds. leather: 65.0 sq. ft.

SCS Indoor Advantage™ Gold and LEVEL® 2 certified. See terms and conditions for additional environmental information.

Seat Height	Arm Height	W	D	H	Fabric	Leather	Weight	Cubes/Qty
16½"	-	60"	31¼"	29"	7.7 yds.	108.0'	139 lbs.	68.33'/1
419 mm	-	1524 mm	794 mm	737 mm	7.1 m	10.0 sqm	63.2 kg	1.93 cu.

COM	COL	1	2	3	4	5	6	7	8	9	10	11
4267	4422	4991	5111	5180	5318	5439	5490	5576	5697	5800	5921	6610

connecting module

mirador 8031B

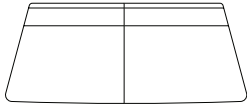
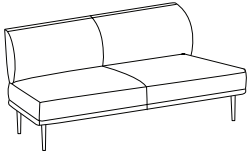

Two-seat armless
Open angle ends
Polished aluminum base
Upholstered

All necessary ganging brackets are included and pre-installed

When using a combination of fabrics or leathers, specify the application by designating the appropriate letter, shown below, on the purchase order. Yardage shown must be used.

See terms and conditions for contrasting upholstery upcharges.

- A) One fabric or leather for seat cushion
yardage: 5.5 yds. leather: 90.0 sq. ft.
- B) One fabric or leather for inside back and outside back
yardage: 4.0 yds. leather: 65.0 sq. ft.

SCS Indoor Advantage™ Gold and LEVEL® 2 certified. See terms and conditions for additional environmental information.

Seat Height	Arm Height	W	D	H	Fabric	Leather	Weight	Cubes/Qty
16½"	-	74"	31¼"	29"	7.7 yds.	108.0'	149 lbs.	80.67/1
419 mm	-	1880 mm	794 mm	737 mm	7.1 m	10.0 sqm	67.7 kg	2.28 cu.

COM	COL	1	2	3	4	5	6	7	8	9	10	11
4267	4422	4991	5111	5180	5318	5439	5490	5576	5697	5800	5921	6610

mirador 8031C

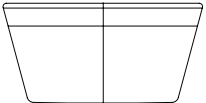
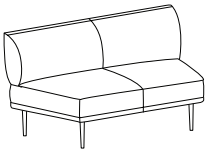

Two-seat armless
Closed angle ends
Polished aluminum base
Upholstered

All necessary ganging brackets are included and pre-installed

When using a combination of fabrics or leathers, specify the application by designating the appropriate letter, shown below, on the purchase order. Yardage shown must be used.

See terms and conditions for contrasting upholstery upcharges.

- A) One fabric or leather for seat cushion
yardage: 5.5 yds. leather: 90.0 sq. ft.
- B) One fabric or leather for inside back and outside back
yardage: 4.0 yds. leather: 65.0 sq. ft.

SCS Indoor Advantage™ Gold and LEVEL® 2 certified. See terms and conditions for additional environmental information.

Seat Height	Arm Height	W	D	H	Fabric	Leather	Weight	Cubes/Qty
16½"	-	60"	31¼"	29"	7.7 yds.	108.0'	129 lbs.	68.33/1
419 mm	-	1524 mm	794 mm	737 mm	7.1 m	10.0 sqm	58.6 kg	1.93 cu.

COM	COL	1	2	3	4	5	6	7	8	9	10	11
4267	4422	4991	5111	5180	5318	5439	5490	5576	5697	5800	5921	6610

connecting module

mirador 8032A

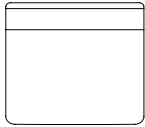

Armless
Straight ends
Polished aluminum base
Upholstered

All necessary ganging brackets are included and pre-installed

When using a combination of fabrics or leathers, specify the application by designating the appropriate letter, shown below, on the purchase order. Yardage shown must be used.

See terms and conditions for contrasting upholstery upcharges.

- A) One fabric or leather for seat cushion
yardage: 3.5 yds. leather: 57.0 sq. ft.
- B) One fabric or leather for inside back and outside back
yardage: 2.5 yds. leather: 41.0 sq. ft.

SCS Indoor Advantage™ Gold and LEVEL® 2 certified. See terms and conditions for additional environmental information.

Seat Height	Arm Height	W	D	H	Fabric	Leather	Weight	Cubes/Qty
16½"	-	30"	31¼"	29"	4.0 yds.	50.0'	68 lbs.	36.09/1
419 mm	-	762 mm	794 mm	737 mm	3.7 m	4.6 sqm	30.9 kg	1.04 cu.

COM	COL	1	2	3	4	5	6	7	8	9	10	11
2848	2928	3222	3284	3320	3391	3453	3480	3524	3586	3640	3702	4057

mirador 8032B

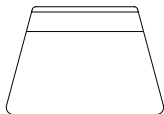
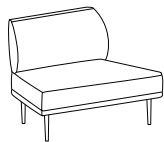

Armless
Open angle ends
Polished aluminum base
Upholstered

All necessary ganging brackets are included and pre-installed

When using a combination of fabrics or leathers, specify the application by designating the appropriate letter, shown below, on the purchase order. Yardage shown must be used.

See terms and conditions for contrasting upholstery upcharges.

- A) One fabric or leather for seat cushion
yardage: 3.5 yds. leather: 57.0 sq. ft.
- B) One fabric or leather for inside back and outside back
yardage: 2.5 yds. leather: 41.0 sq. ft.

SCS Indoor Advantage™ Gold and LEVEL® 2 certified. See terms and conditions for additional environmental information.

Seat Height	Arm Height	W	D	H	Fabric	Leather	Weight	Cubes/Qty
16½"	-	44"	31¼"	29"	4.0 yds.	50.0'	71 lbs.	68.33/1
419 mm	-	1118 mm	794 mm	737 mm	3.7 m	4.6 sqm	32.2 kg	1.93 cu.

COM	COL	1	2	3	4	5	6	7	8	9	10	11
2848	2928	3222	3284	3320	3391	3453	3480	3524	3586	3640	3702	4057

connecting module

mirador 8032C

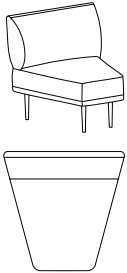

Armless
Closed angle ends
Polished aluminum base
Upholstered

All necessary ganging brackets are included and pre-installed

When using a combination of fabrics or leathers, specify the application by designating the appropriate letter, shown below, on the purchase order. Yardage shown must be used.

See terms and conditions for contrasting upholstery upcharges.

- A) One fabric or leather for seat cushion
yardage: 3.5 yds. leather: 57.0 sq. ft.
- B) One fabric or leather for inside back and outside back
yardage: 2.5 yds. leather: 41.0 sq. ft.

SCS Indoor Advantage™ Gold and LEVEL® 2 certified. See terms and conditions for additional environmental information.

Seat Height	Arm Height	W	D	H	Fabric	Leather	Weight	Cubes/Qty
16½"	-	30"	31¼"	29"	4.0 yds.	50.0'	58 lbs.	22.69/1
419 mm	-	762 mm	794 mm	737 mm	3.7 m	4.6 sqm	26.4 kg	.64 cu.

COM	COL	1	2	3	4	5	6	7	8	9	10	11
2848	2928	3222	3284	3320	3391	3453	3480	3524	3586	3640	3702	4057

mirador 8033A

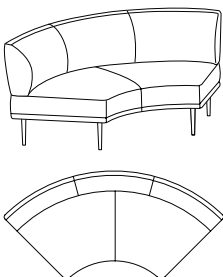

Armless
Closed angle ends
Polished aluminum base
Upholstered

All necessary ganging brackets are included and pre-installed

When using a combination of fabrics or leathers, specify the application by designating the appropriate letter, shown below, on the purchase order. Yardage shown must be used.

See terms and conditions for contrasting upholstery upcharges.

- A) One fabric or leather for seat cushion
yardage: 6.0 yds. leather: 98.0 sq. ft.
- B) One fabric or leather for inside back and outside back
yardage: 6.0 yds. leather: 98.0 sq. ft.

SCS Indoor Advantage™ Gold and LEVEL® 2 certified. See terms and conditions for additional environmental information.

Seat Height	Arm Height	W	D	H	Fabric	Leather	Weight	Cubes/Qty
16½"	-	77"	31¼"	29"	8.5 yds.	120.0'	153 lbs.	80.67/1
419 mm	-	1956 mm	794 mm	737 mm	7.8 m	11.2 sqm	69.5 kg	2.28 cu.

COM	COL	1	2	3	4	5	6	7	8	9	10	11
4978	5148	5772	5904	5980	6131	6263	6320	6414	6546	6660	6792	7547

mirador 8034A

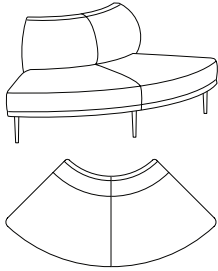

Armless
Open angle ends
Polished aluminum base
Upholstered

All necessary ganging brackets are included and pre-installed

When using a combination of fabrics or leathers, specify the application by designating the appropriate letter, shown below, on the purchase order. Yardage shown must be used.

See terms and conditions for contrasting upholstery upcharges.

- A) One fabric or leather for seat cushion
 yardage: 6.0 yds. leather: 98.0 sq. ft.
- B) One fabric or leather for inside back and outside back
 yardage: 3.0 yds. leather: 50.0 sq. ft.

SCS Indoor Advantage™ Gold and LEVEL® 2 certified. See terms and conditions for additional environmental information.

Seat Height	Arm Height	W	D	H	Fabric	Leather	Weight	Cubes/Qty
16½"	-	73"	31¼"	29"	6.3 yds.	80.0'	135 lbs.	80.67/1
419 mm	-	1854 mm	794 mm	737 mm	5.8 m	7.4 sqm	61.4 kg	2.28 cu.

COM	COL	1	2	3	4	5	6	7	8	9	10	11
4978	5104	5566	5664	5720	5832	5930	5972	6042	6140	6224	6322	6882

mirador 8035A

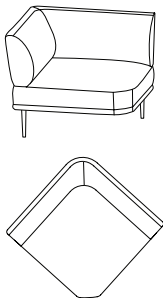

Corner connector
Straight ends
Polished aluminum base
Upholstered

All necessary ganging brackets are included and pre-installed
 May not be used at the end of a configuration or as a freestanding unit

When using a combination of fabrics or leathers, specify the application by designating the appropriate letter, shown below, on the purchase order. Yardage shown must be used.

See terms and conditions for contrasting upholstery upcharges.

- A) One fabric or leather for seat cushion
 yardage: 4.5 yds. leather: 73.0 sq. ft.
- B) One fabric or leather for inside back, outside back and side arms
 yardage: 3.75 yds. leather: 61.0 sq. ft.

SCS Indoor Advantage™ Gold and LEVEL® 2 certified. See terms and conditions for additional environmental information.

Seat Height	Arm Height	W	D	H	Fabric	Leather	Weight	Cubes/Qty
16½"	-	38"	38"	29"	6.0 yds.	98.0'	81 lbs.	32.10/1
419 mm	-	965 mm	965 mm	737 mm	3.7 m	5.6 sqm	36.8 kg	.91 cu.

COM	COL	1	2	3	4	5	6	7	8	9	10	11
3378	3498	3938	4032	4085	4192	4285	4325	4392	4485	4565	4658	5192

mirador 8040A



**Freestanding bench
Polished aluminum base
Upholstered**

Levelers and non-marring glides

See terms and conditions for contrasting upholstery upcharges.

SCS Indoor Advantage™ Gold and LEVEL® 2 certified. See terms and conditions for additional environmental information.

Seat Height	Arm Height	W	D	H	Fabric	Leather	Weight	Cubes/Qty
16½"	-	30"	28¾"	16½"	3.0 yds	40.0'	55 lbs	22.67/1
419 mm	-	762 mm	730 mm	419 mm	2.7 m	3.7 sqm	25.0 kg	.64 cu

COM	COL	1	2	3	4	5	6	7	8	9	10	11
1606	1666	1886	1933	1960	2013	2060	2080	2113	2160	2200	2246	2513

mirador 8041A

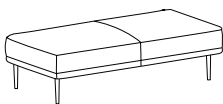

**Two-seat freestanding bench
Polished aluminum base
Upholstered**

Levelers and non-marring glides

SCS Indoor Advantage™ Gold and LEVEL® 2 certified. See terms and conditions for additional environmental information.

Seat Height	Arm Height	W	D	H	Fabric	Leather	Weight	Cubes/Qty
16½"	-	60"	28¾"	16½"	5.5 yds	75.0'	122 lbs	68.33/1
419 mm	-	1524 mm	730 mm	419 mm	5.0 m	7.0 sqm	55.5 kg	1.93 cu

COM	COL	1	2	3	4	5	6	7	8	9	10	11
2493	2603	3007	3092	3141	3239	3325	3361	3422	3508	3581	3667	4156

mirador 8042A

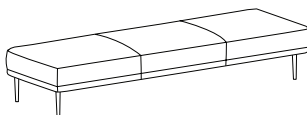

**Three-seat freestanding bench
Polished aluminum base
Upholstered**

Levelers and non-marring glides

SCS Indoor Advantage™ Gold and LEVEL® 2 certified. See terms and conditions for additional environmental information.

Seat Height	Arm Height	W	D	H	Fabric	Leather	Weight	Cubes/Qty
16½"	-	90"	28¾"	16½"	7.5 yds	101.0'	181 lbs	101.65/1
419 mm	-	2286 mm	730 mm	419 mm	6.9 m	9.4 sqm	82.3 kg	2.87 cu

COM	COL	1	2	3	4	5	6	7	8	9	10	11
2670	2820	3370	3487	3554	3687	3804	3854	3937	4054	4154	4270	4937

Neighborhood Seating System Specification Guide

Overview

Neighborhood is a modular seating and table system consisting of thirty-nine unique modules for use in creating an unlimited number of configurations. Options include single sided, double sided and privacy modules as well as freestanding modules for use with any configuration. To select modules appropriate for your application use the scope of line shown on the following pages.

Neighborhood tables are available with worksurfaces in oak veneer in a variety of standard finishes, designer white laminate, or glacier white corian® as connecting modules and freestanding units. Power + USB duplex options are available.

Pivoting connectors join units in a configuration. When rotated inward, connectors are concealed allowing the modules to be used independently.

When specifying the privacy modules, please verify that the specified sku is within size requirements for delivery (elevators, hall intersections, doorways, stairwells).

Visit BernhardtDesign.com for a complete drawing library of 2D, 3D and Revit models. Neighborhood is SCS Indoor Advantage® Gold and LEVEL® 2 certified.

You may also contact your local sales representative or the Bernhardt Design corporate office for specification assistance.

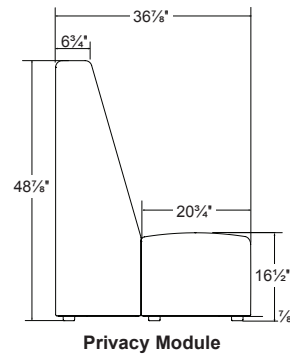
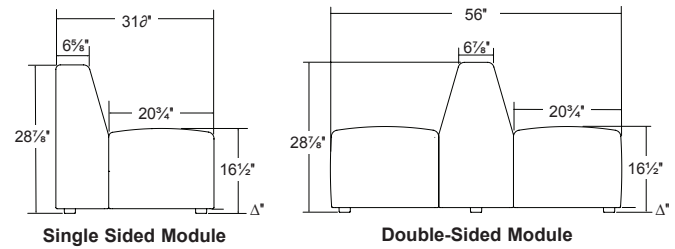

Upholstery Specification Guide

The Neighborhood seating and table modules are fully upholstered with a saddle stitch or a jump master stitch. Thread color must be specified for the jump master stitch. Reference Neighborhood/Stitching on BernhardtDesign.com for thread color options available for jump master stitch only.

Leather may be specified for single sided, double sided, privacy and table modules. Leather is not applicable on the back and back side panel of privacy modules. Approved leather alternatives or fabric may be used on all Neighborhood frames.

When ordering multi-item configurations, please provide the total COM yardage from the same dye lot in a continuous roll(s).



Saddle Stitch



Jump Master Stitch

COM/COL Preapproval Requirements

When specifying stripes or fabrics with linear grain, the curvature of certain frames may affect the pattern alignment. As a result, the COM/COL preapproval procedure requires 1/2 yard of fabric or leather alternative, or 1 sq. ft. leather to be submitted for testing for prior approval on all frames except mobile seating, freestanding ottomans, benches and tables.

Preapproval procedure for testing COM/COL for mobile seating, freestanding ottomans and benches, and all tables requires the standard 12" x 12" sample. Reference the terms and conditions for COM/COL approval procedures.

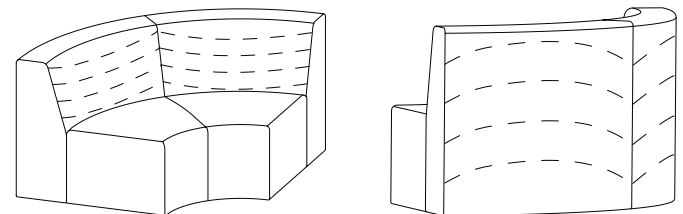

Pattern Alignment When Specifying Directional Grain Fabric

Neighborhood Seating System Specification Guide

A. Mobile Seating

Mobile modules have non-locking casters and are used as freestanding units. The mobile lounge 6030M has a brushed aluminum handle located mid-back.

6021M

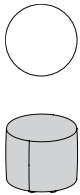

6024M

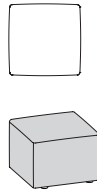

6030M

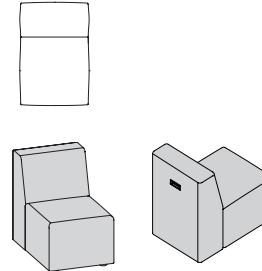

B. Freestanding Ottomans and Benches

Eight non-connecting ottomans and benches are available for use as freestanding units.

6021

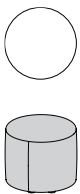

6024

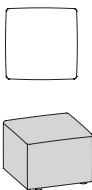

6025

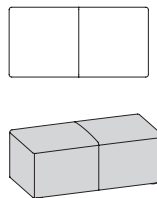

6027

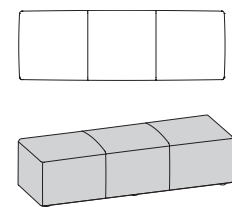

6020

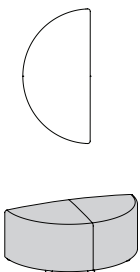

6022

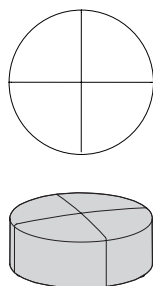

6044

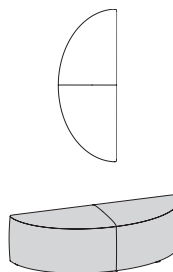

6019

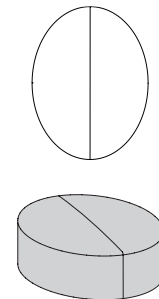

C. Freestanding Work Tables

Freestanding mid height work tables may be used with any configuration or to create a banquette configuration for dining or work applications. Power + USB options are available on 42" and 48" tables.

JR1X - 22" Round

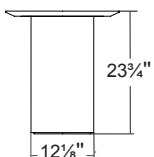

JR2X - 42" Round

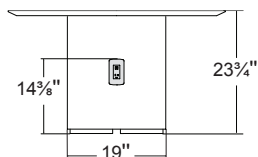

Power + USB (1)

Neighborhood Seating System Specification Guide

D. Single Sided Modules

Single sided connecting modules are used in conjunction with other single sided modules to create seating configurations. Single sided units may not be used with double sided units or privacy units.

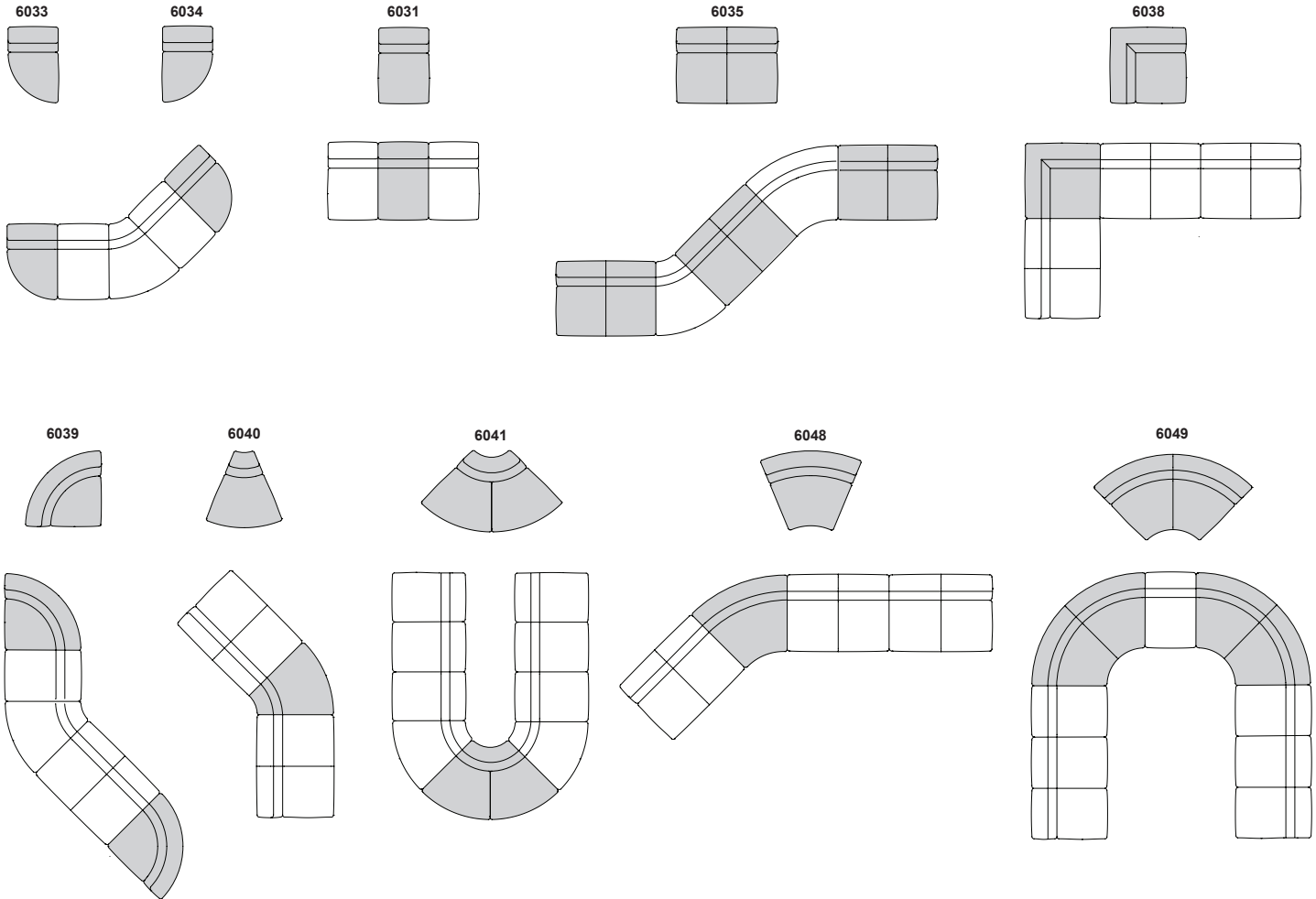

Neighborhood Seating System Specification Guide

F. Double-Sided Modules

Double-sided connecting modules are used in conjunction with other double-sided modules to create seating configurations. Double-sided units may not be used with single sided units or privacy units.

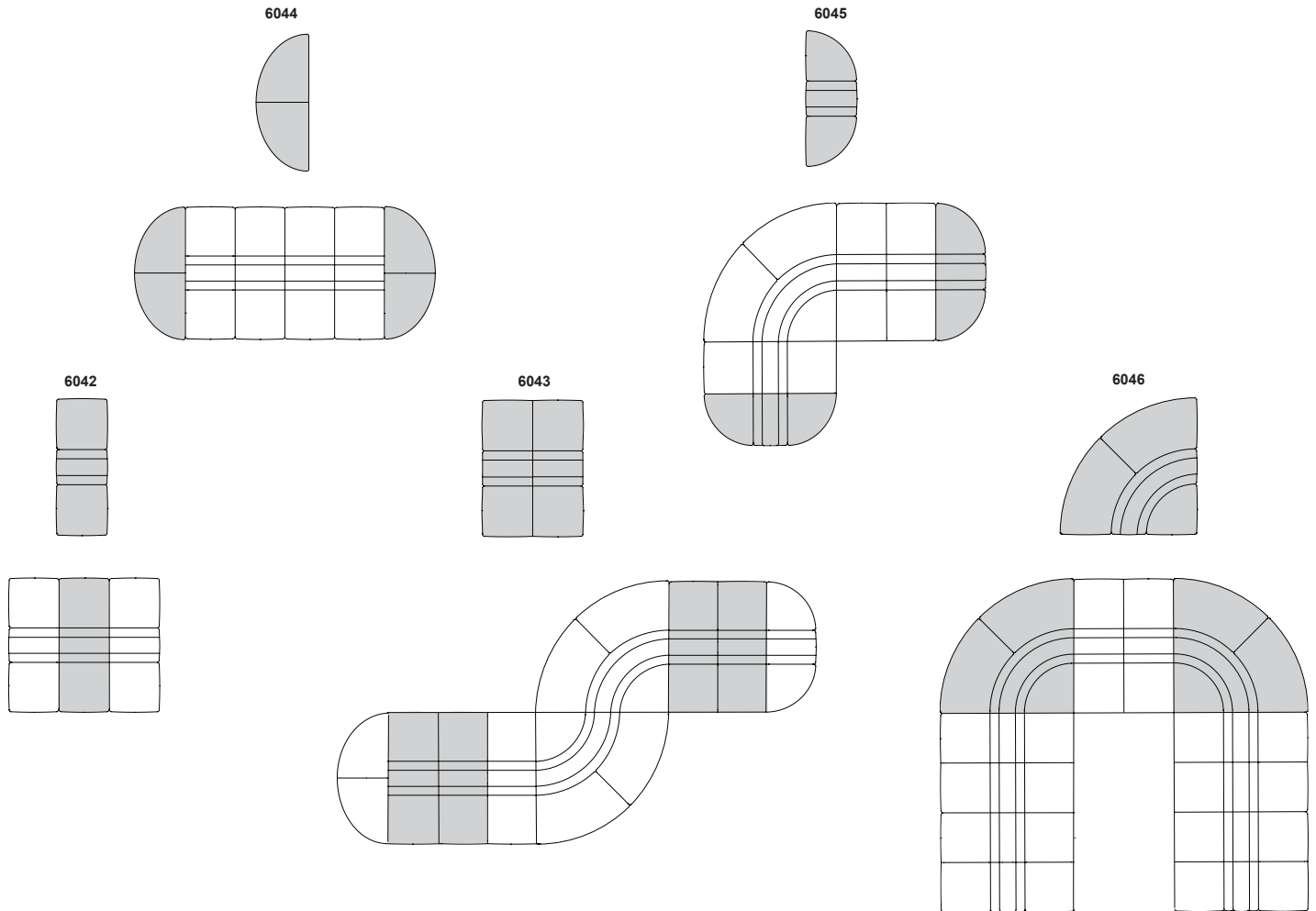

G. Tables for Double-Sided Connecting Modules

Double-sided connecting module tables are used in conjunction with double-sided seating modules. A power/USB option is available on double-sided connecting tables.

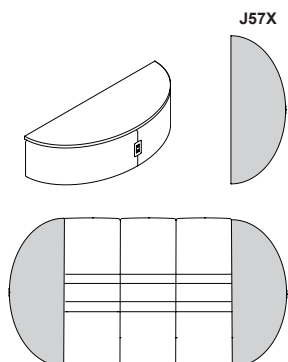

Neighborhood Seating System Specification Guide

H. Privacy Modules

Privacy connecting modules are used in conjunction with other privacy modules to create seating configurations. Privacy units may not be used with single or double sided units.

6031T

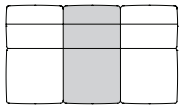

6035T

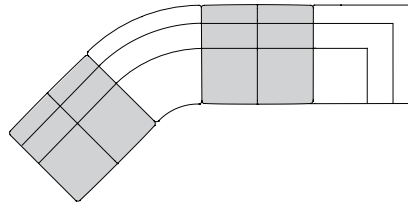

6038T

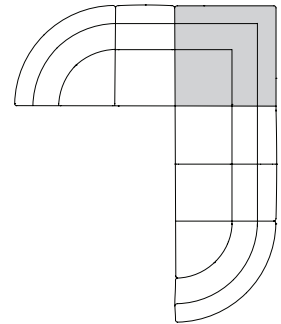
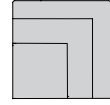

6039T

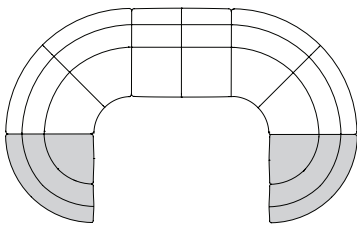
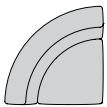

6040T

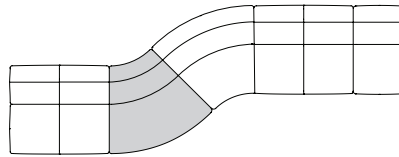
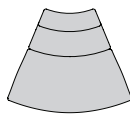

6041T

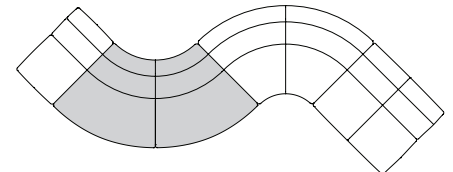
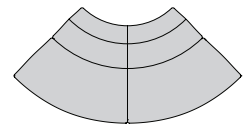

6048T

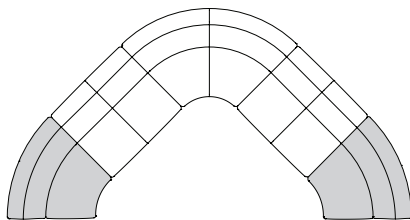
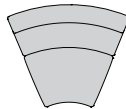

6049T

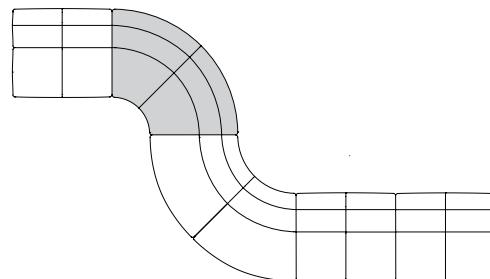
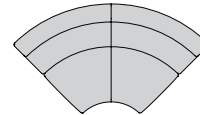

Neighborhood Seating System Specification Guide

Tables for Freestanding and Connecting Modules

Neighborhood tables were designed for use as freestanding units or with single or double-sided connecting modules to create continuous configurations. Connecting tables are not available for use with privacy modules.

The Neighborhood table worksurface is available in oak veneer, laminate or corian. Connecting tables have a flat edge profile; freestanding table edges are beveled.

The base is fully upholstered with saddle stitching or a jump master stitch. Thread color must be specified for the jump master stitch. Reference Neighborhood/Stitching on BernhardtDesign.com for thread color options. When ordering multi-item configurations, please provide the total **COM** yardage from the same dye lot in a continuous roll(s).

Power + USB modules are optional and upcharges apply. Reference information on the following page for power options specifics.

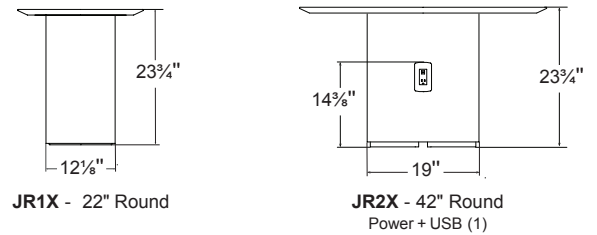

Surface Selection

Laminate

Order Code - F
Designer White
Wilsonart® D-354-60

Corian®

Order Code - 8
Glacier White

OAK Oak

Standard Finish
871 860 870
837 836 861
865 805 866
872 839 845
Select Finish
M73 M71 M75
M74 M76 M77

Edge Profiles

Freestanding Tables

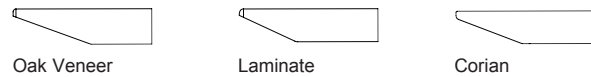

End Tables

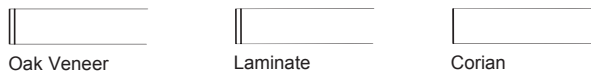

Connecting Modules

Neighborhood modules connect by inserting the ganging fork into the bracket plate located on the underside of the furniture. To connect modules, rotate the connecting forks perpendicular to the module and slide the modules together. The forks fit around the bracket plates when the modules are connected. Use the leveling glides as needed to align the overall height of the modules on uneven flooring surfaces.

To disconnect modules, lift the side of the module where the bracket plates are located, generally the left hand facing side. Pull to disconnect the brackets from the connecting forks and slide apart.

Modules used in configurations may also be used as freestanding units. The connector fork can be concealed by rotating the connecting fork underneath the furniture module.

Hardware is provided with the 180° curved module for left or right hand orientation.

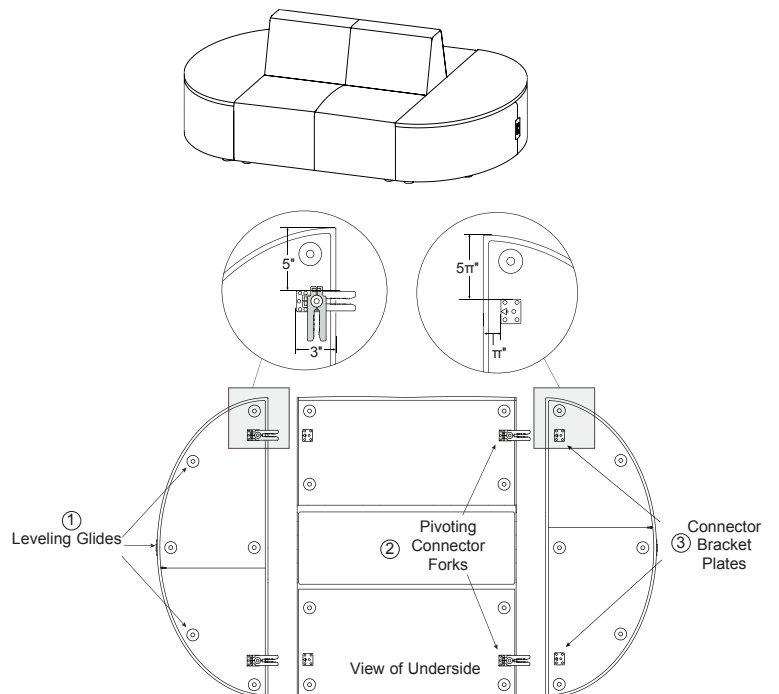

Neighborhood Seating System Specification Guide

Power Module

An optional power + USB module is available for all Neighborhood tables except the 22" round table. Single sided connecting tables and the 42" round freestanding tables are available with a single power module; double-sided connecting tables and the 42" and 48" square freestanding tables are available with two modules. Upcharges apply as indicated on the price list for each table.

The power module has (1) 15 amp receptacle, (1) 2 amp USB-A port and (1) 2 amp USB-C port for charging tablets or other USB friendly devices. The power module is UL approved and includes a 10', 14/3 SJT black power cord with right angle plug. The power module has an aluminum powder coat finish and installs in the side of the base. An underside zipper allows access to power.

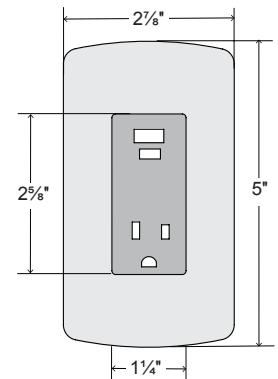

Connecting Module Tables Power Management



180° Curved End Module Table

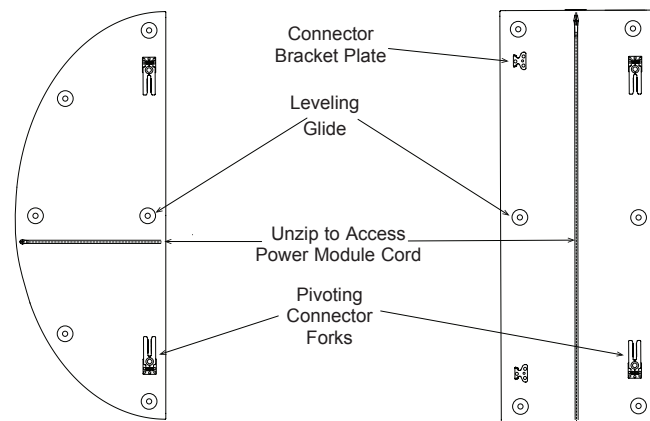

Underside View of Connecting Module Tables

Freestanding Tables Power Management



Mid Height Round Work Table

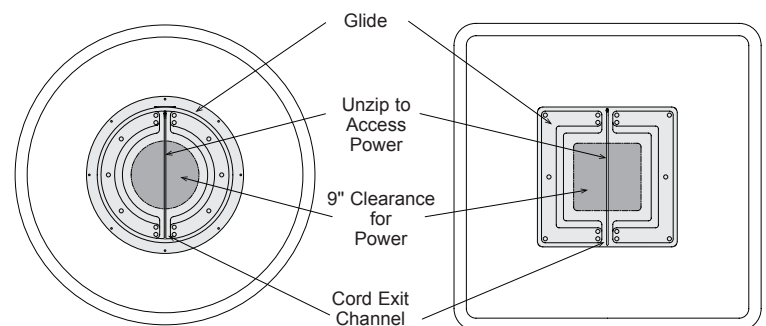

Underside View of Freestanding Tables

Neighborhood Seating System Sample Configurations

Single Sided Connecting Modules



1



2



3



4



5



6



7



8



9



10



11



12



13



14

Neighborhood Seating System Sample Configurations

Double-Sided Connecting Modules



15

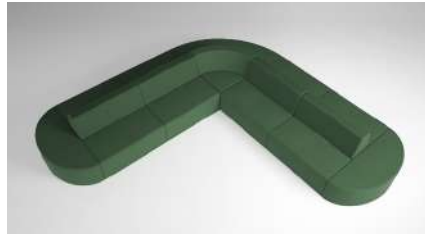

16



17



18

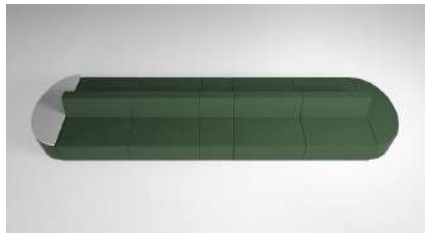

19



20

Privacy Connecting Modules



21



22



23



24



25



26



27



28



29



30



31



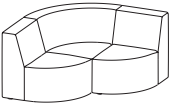
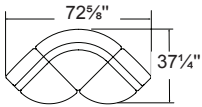
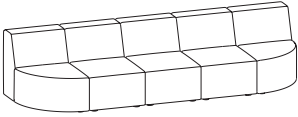
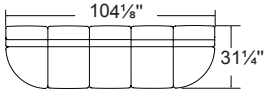
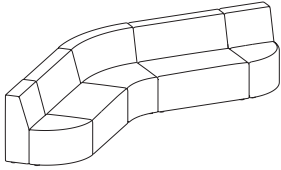
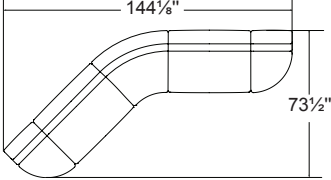
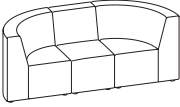
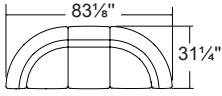
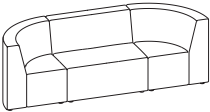
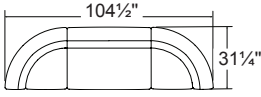
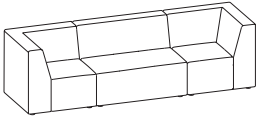
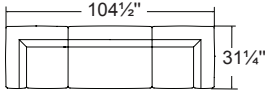
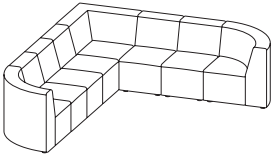
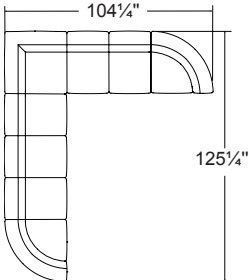

32

Neighborhood Seating System Sample Configurations

		Sku	Description
1			<p>6033 Single Seat, Left End Facing 6039 90° Curved Corner Connector 6034 Single Seat, Right End Facing</p>
2			<p>6033 Single Seat, Left End Facing 6031 Single Seat Straight Connector (3) 6034 Single Seat, Right End Facing</p>
3			<p>6033 Single Seat, Left End Facing 6035 Two-seat Straight Connector 6048 45° Curved Connector 6035 Two-seat Straight Connector 6034 Single Seat, Right End Facing</p>
4			<p>6039 90° Curved Corner Connector 6031 Single Seat Straight Connector 6039 90° Curved Corner Connector</p>
5			<p>6039 90° Curved Corner Connector 6035 Two-seat Straight Connector 6039 90° Curved Corner Connector</p>
6			<p>6038 90° Corner Connector 6035 Two-seat Straight Connector 6038 90° Corner Connector</p>
7			<p>6039 90° Curved Corner Connector 6031 Single Seat Straight Connector (3) 6038 90° Corner Connector 6031 Single Seat Straight Connector (2) 6039 90° Curved Corner Connector</p>

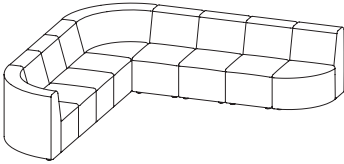
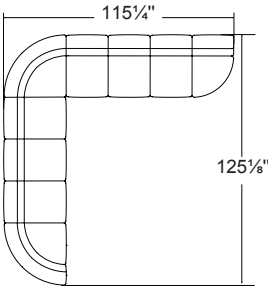
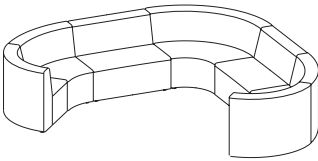
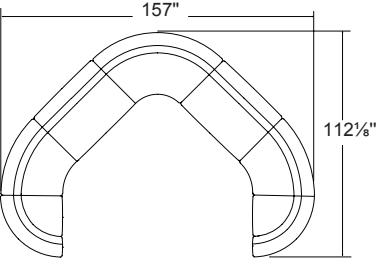
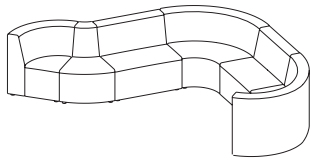
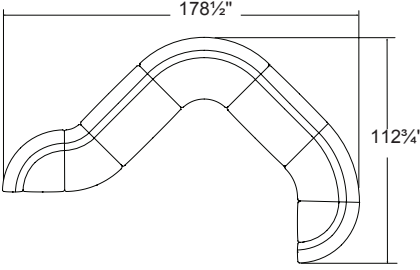
Neighborhood Seating System Sample Configurations

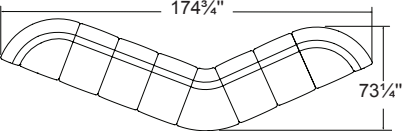
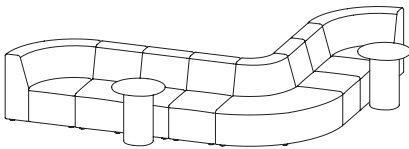
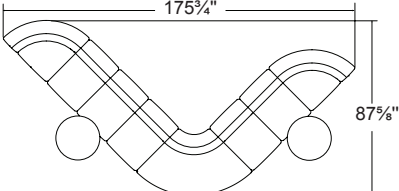
		SKU	Description
8	 	6039 6031 6039 6031 6034	90° Curved Corner Connector Single Seat Straight Connector (3) 90° Curved Corner Connector Single Seat Straight Connector (3) Single Seat, Right End Facing
9	 	6039 6048 6035 6049 6035 6048 6039	90° Curved Corner Connector 45° Curved Connector Two-seat Straight Connector 90° Curved Connector Two-seat Straight Connector 45° Curved Connector 90° Curved Corner Connector
10	 	6039 6040 6035 6049 6035 6048 6039	90° Curved Corner Connector 45° Inverted Curved Connector Two-seat Straight Connector 90° Curved Connector Two-seat Straight Connector 45° Curved Connector 90° Curved Corner Connector
11	 	6039 6031 6040 6031 6039	90° Curved Corner Connector Single Seat Straight Connector (3) 45° Inverted Curved Connector Single Seat Straight Connector (2) 90° Curved Corner Connector
12	 	6039 6031 6041 6031 6039 JR1X	90° Curved Corner Connector Single Seat Straight Connector (3) 90° Inverted Curved Connector Single Seat Straight Connector (2) 90° Curved Corner Connector 22" Round Table (2)

Neighborhood Seating System Sample Configurations

13

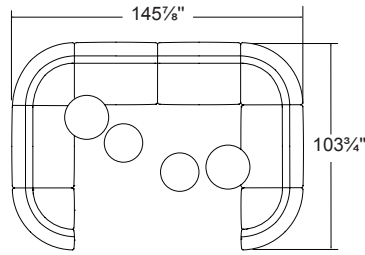
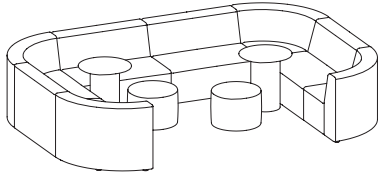

- | SKU | Description |
|------|---------------------------------|
| 6039 | 90° Curved Corner Connector |
| 6035 | Two-seat Straight Connector |
| 6039 | 90° Curved Corner Connector |
| 6035 | Two-seat Straight Connector (2) |
| 6039 | 90° Curved Corner Connector |
| 6035 | Two-seat Straight Connector |
| 6039 | 90° Curved Corner Connector |
| 6021 | Round Ottoman (2) |
| JR1X | 22" Round Table (2) |

14

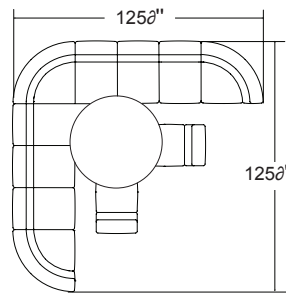
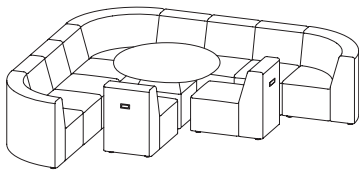

- | | |
|-------|------------------------------------|
| 6039 | 90° Curved Corner Connector |
| 6031 | Single Seat Straight Connector (3) |
| 6039 | 90° Curved Corner Connector |
| 6031 | Single Seat Straight Connector (3) |
| 6039 | 90° Curved Corner Connector |
| 6030M | Mobile Single Seat Module (2) |
| JS2X | 42" Round Table |

15

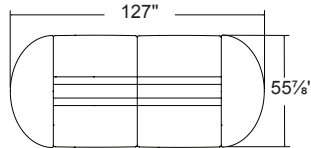
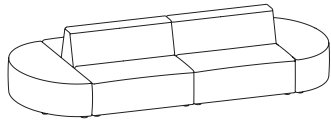

- | | |
|------|--|
| 6044 | 180° Curved Half Oval End Module |
| 6043 | Double-Sided Two-seat Straight Connector (2) |
| 6044 | 180° Curved Half Oval End Module |

16

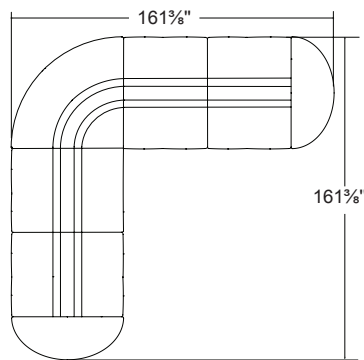
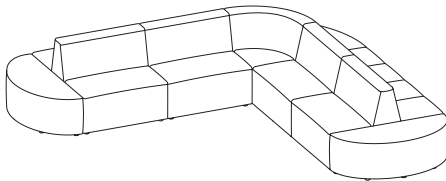

- | | |
|------|--|
| 6044 | 180° Curved Half Oval End Module |
| 6043 | Double-Sided Two-seat Straight Connector (2) |
| 6046 | Double-Sided 90° Curved Connector |
| 6043 | Double-Sided Two-seat Straight Connector (2) |
| 6044 | 180° Curved Half Oval End Module |

Neighborhood Seating System Sample Configurations

17

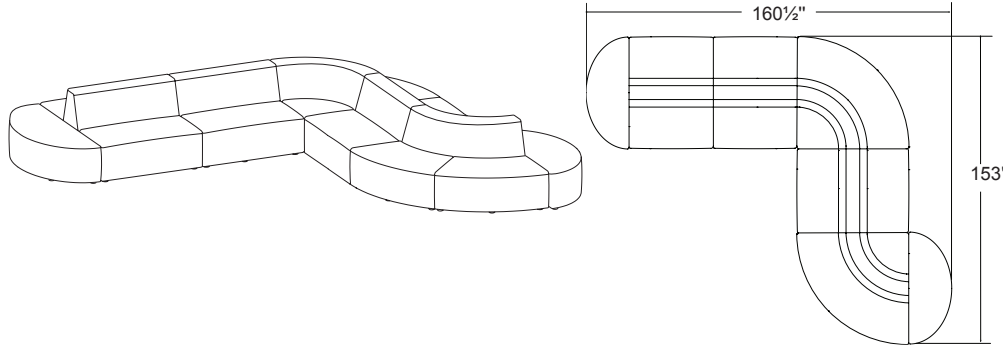

Sku Description

- 6044** 180° Curved Half Oval End Module
- 6043** Double-Sided Two-seat Straight Connector (2)
- 6046** Double-Sided 90° Curved Connector
- 6043** Double-Sided Two-seat Straight Connector
- 6046** Double-Sided 90° Curved Connector
- 6044** 180° Curved Half Oval End Module

18

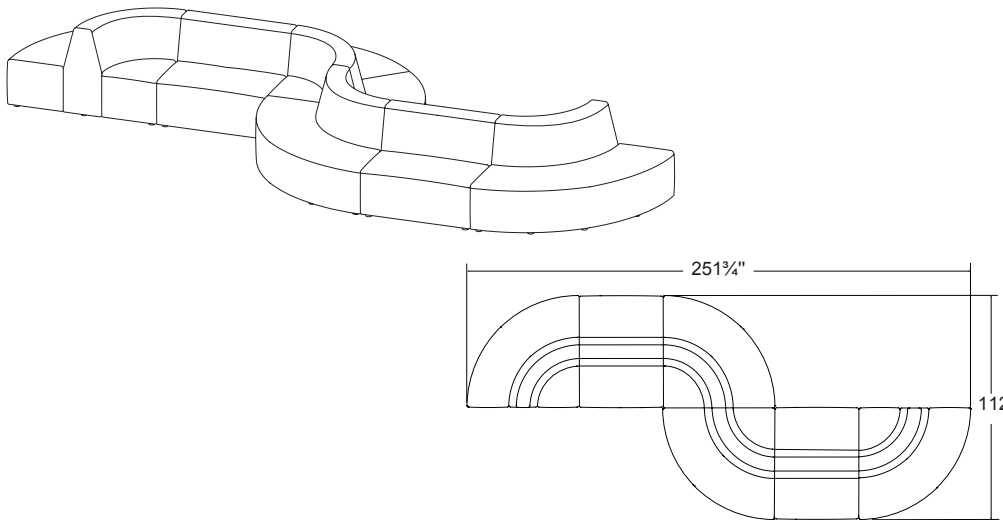

- 6046** Double-Sided 90° Curved Connector
- 6043** Double-Sided Two-seat Straight Connector
- 6046** Double-Sided 90° Curved Connector (2)
- 6043** Double-Sided Two-seat Straight Connector
- 6046** Double-Sided 90° Curved Connector

19

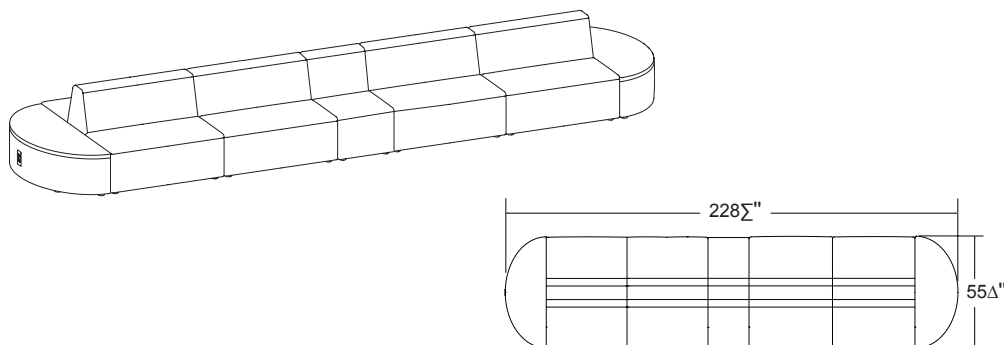

- J57X** 180° Curved End Module Table
- 6043** Double-Sided Two-seat Straight Connector (2)
- 6042** Double-Sided Single-seat Straight Connector
- 6043** Double-Sided Two-seat Straight Connector (2)
- 6044** 180° Curved Half Oval End Module

Neighborhood Seating System Sample Configurations

20

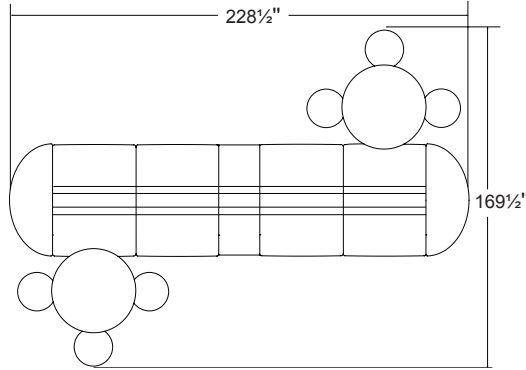
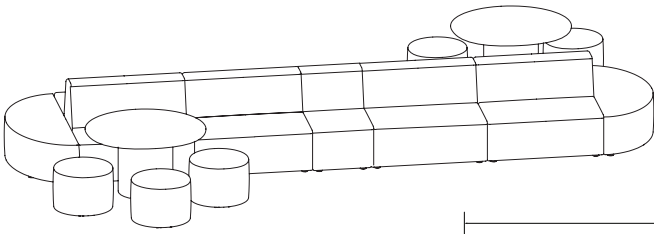

SKU	DESCRIPTION
6044	180° Curved Half Oval End Module
6043	Double-Sided Two-seat Straight Connector (2)
6042	Double-Sided Single-seat Straight Connector
6043	Double-Sided Two-seat Straight Connector (2)
6044	180° Curved Half Oval End Module
6021	Round Ottoman (6)
JR2X	42" Round Table (2)

21

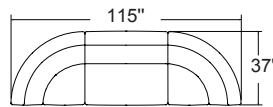
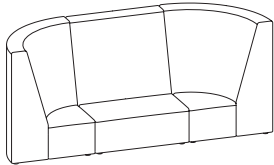

6039T	90° Curved Corner Privacy Connector
6035T	Two-seat Straight Privacy Connector
6039T	90° Curved Corner Privacy Connector

22

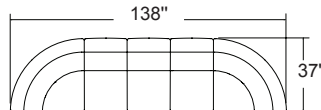
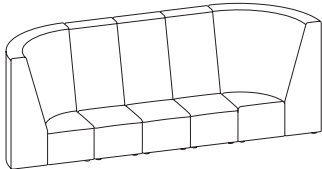

6039T	90° Curved Corner Privacy Connector
6031T	Single Seat Straight Privacy Connector (3)
6039T	90° Curved Corner Privacy Connector

23

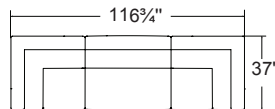
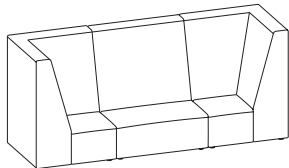

6038T	90° Corner Privacy Connector
6035T	Two-seat Straight Privacy Connector
6038T	90° Corner Privacy Connector

24

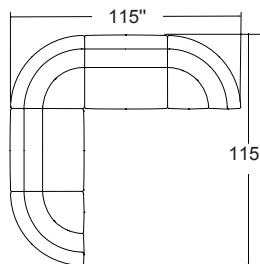
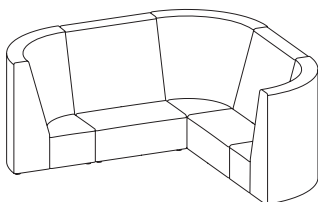

6039T	90° Curved Corner Privacy Connector
6035T	Two-seat Straight Privacy Connector
6039T	90° Curved Corner Privacy Connector
6035T	Two-seat Straight Privacy Connector
6039T	90° Curved Corner Privacy Connector

Neighborhood Seating System Sample Configurations

25

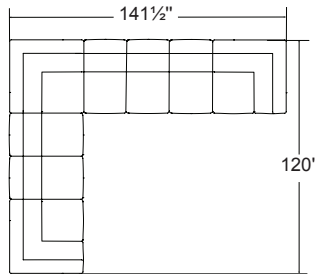
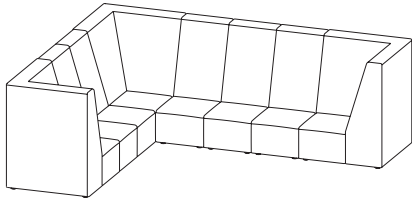

Sku Description

- 6038T** 90° Corner Privacy Connector
- 6031T** Single Seat Straight Privacy Connector (2)
- 6038T** 90° Corner Privacy Connector
- 6031T** Single Seat Straight Privacy Connector (3)
- 6038T** 90° Corner Privacy Connector

26

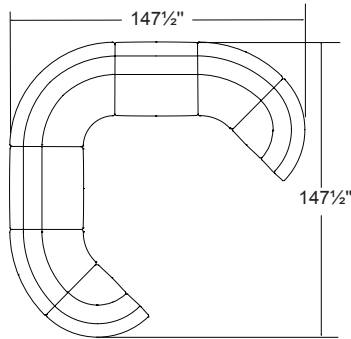
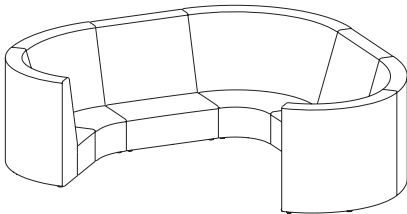

- 6039T** 90° Curved Corner Privacy Connector
- 6048T** 45° Curved Privacy Connector
- 6035T** Two-seat Straight Privacy Connector
- 6049T** 90° Curved Privacy Connector
- 6035T** Two-seat Straight Privacy Connector
- 6048T** 45° Curved Privacy Connector
- 6039T** 90° Curved Corner Privacy Connector

27

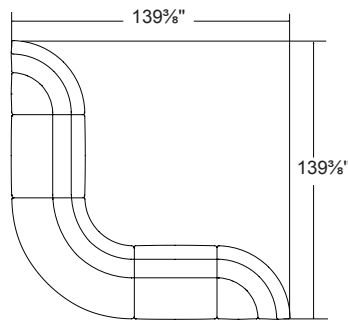
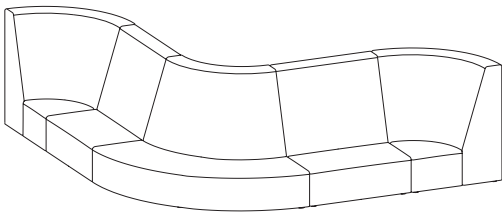

- 6039T** 90° Curved Corner Privacy Connector
- 6035T** Two-seat Straight Privacy Connector
- 6041T** 90° Inverted Curved Privacy Connector
- 6035T** Two-seat Straight Privacy Connector
- 6039T** 90° Curved Corner Privacy Connector

28

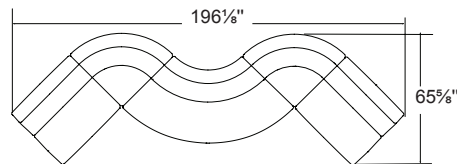
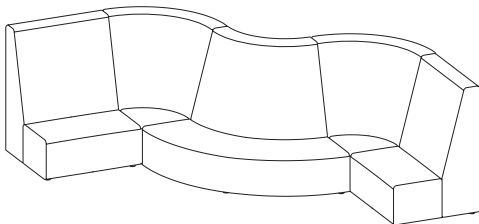

- 6035T** Two-seat Straight Privacy Connector
- 6039T** 90° Curved Corner Privacy Connector
- 6041T** 90° Inverted Curved Privacy Connector
- 6039T** 90° Curved Corner Privacy Connector
- 6035T** Two-seat Straight Privacy Connector

Neighborhood Seating System Sample Configurations

29

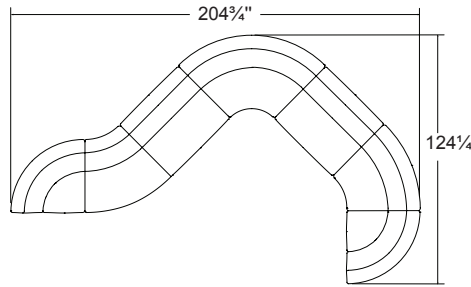
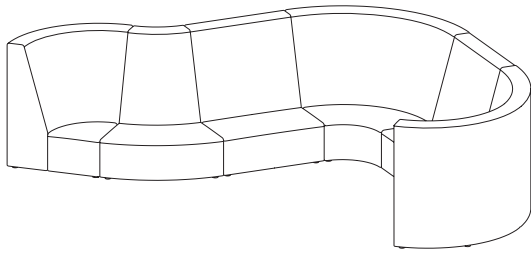

- | SKU | DESCRIPTION |
|-------|---------------------------------------|
| 6039T | 90° Curved Corner Privacy Connector |
| 6040T | 45° Inverted Curved Privacy Connector |
| 6035T | Two-seat Straight Privacy Connector |
| 6049T | 90° Curved Privacy Connector |
| 6035T | Two-seat Straight Privacy Connector |
| 6048T | 45° Curved Privacy Connector |
| 6039T | 90° Curved Corner Privacy Connector |

30

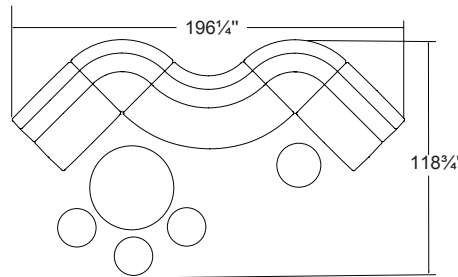
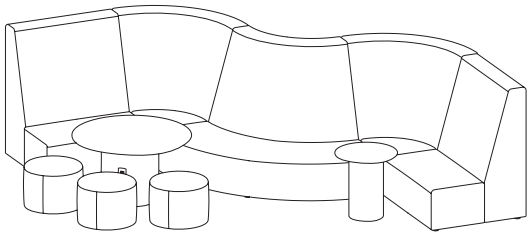

- | | |
|-------|---------------------------------------|
| 6035T | Two-seat Straight Privacy Connector |
| 6039T | 90° Curved Corner Privacy Connector |
| 6041T | 90° Inverted Curved Privacy Connector |
| 6039T | 90° Curved Corner Privacy Connector |
| 6035T | Two-seat Straight Privacy Connector |
| 6021 | Round Ottomans (3) |
| JR2X | 42" Round Table |
| JR1X | 22" Round Table |

31

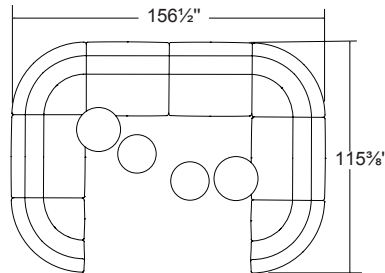
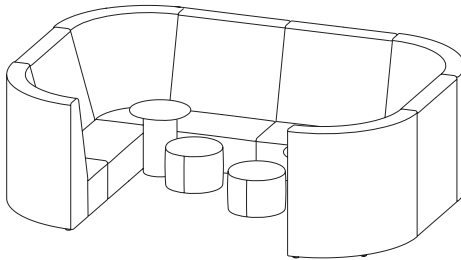

- | | |
|-------|---|
| 6039T | 90° Curved Corner Privacy Connector |
| 6035T | Two-seat Straight Privacy Connector |
| 6039T | 90° Curved Corner Privacy Connector |
| 6035T | Two-seat Straight Privacy Connector (2) |
| 6039T | 90° Curved Corner Privacy Connector |
| 6035T | Two-seat Straight Privacy Connector |
| 6039T | 90° Curved Corner Privacy Connector |
| 6021 | Round Ottoman (2) |
| JR1X | 22" Round Table (2) |

32

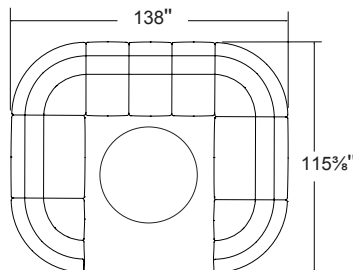
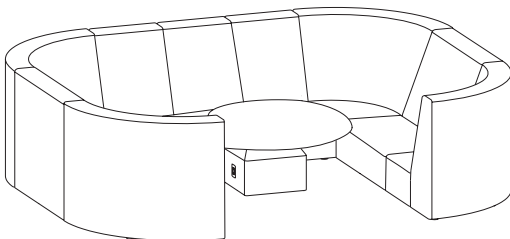

- | | |
|-------|--|
| 6039T | 90° Curved Corner Privacy Connector |
| 6035T | Two-seat Straight Privacy Connector |
| 6039T | 90° Curved Corner Privacy Connector |
| 6031T | Single Seat Straight Privacy Connector (3) |
| 6039T | 90° Curved Corner Privacy Connector |
| 6035T | Two-seat Straight Privacy Connector |
| 6039T | 90° Curved Corner Privacy Connector |
| JR2X | 42" Round Table |

Freestanding

neighborhood 6021M



Round mobile ottoman
Fully upholstered
Saddle stitched

Eight casters

SCS Indoor Advantage™ Gold and LEVEL® 2 certified. See terms and conditions for additional environmental information.

Seat Height	Arm Height	W	D	H	Fabric	Leather	Weight	Cubes/Qty
16½"	-	21"	20"	16½"	1.75 yds.	24.0'	30 lbs.	10.0'/1
419 mm	-	533 mm	533 mm	419 mm	1.6 m	2.2 sqm	13.6 kg	.28 cu.

COM	COL	1	2	3	4	5	6	7	8	9	10	11
1019	1054	1183	1210	1226	1257	1284	1296	1315	1342	1366	1393	1548

neighborhood 6021MJ



Round mobile ottoman
Fully upholstered
Jump master stitched

Eight casters

SCS Indoor Advantage™ Gold and LEVEL® 2 certified. See terms and conditions for additional environmental information.

Jump Master Stitch Specification: Thread color must be specified. Reference Neighborhood/Stitching on BernhardtDesign.com for thread color options.

Seat Height	Arm Height	W	D	H	Fabric	Leather	Weight	Cubes/Qty
16½"	-	21"	21"	16½"	1.75 yds.	24.0'	30 lbs.	10.0'/1
419 mm	-	533 mm	533 mm	419 mm	1.6 m	2.2 sqm	13.6 kg	.28 cu.

COM	COL	1	2	3	4	5	6	7	8	9	10	11
1096	1131	1260	1287	1303	1334	1361	1373	1392	1419	1443	1470	1625

neighborhood 6024M

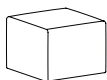

Mobile square Ottoman.
Fully upholstered
Saddle stitched

Four casters

SCS Indoor Advantage™ Gold and LEVEL® 2 certified. See terms and conditions for additional environmental information.

Seat Height	Arm Height	W	D	H	Fabric	Leather	Weight	Cubes/Qty
16½"	-	21"	20"	16½"	2.25 yds.	30.0'	37 lbs.	10.0'/1
419 mm	-	533 mm	533 mm	419 mm	2.1 m	2.8 sqm	16.8 kg	.28 cu.

COM	COL	1	2	3	4	5	6	7	8	9	10	11
941	986	1151	1186	1206	1246	1281	1296	1321	1356	1386	1421	1621

Freestanding

neighborhood 6024MJ

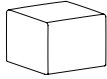

Mobile square ottoman
Fully upholstered
Jump master stitched

Four casters

SCS Indoor Advantage™ Gold and LEVEL® 2 certified. See terms and conditions for additional environmental information.

Jump Master Stitch Specification: Thread color must be specified. Reference Neighborhood/Stitching on BernhardtDesign.com for thread color options.

Seat Height	Arm Height	W	D	H	Fabric	Leather	Weight	Cubes/Qty
16½"	-	21"	21"	16½"	2.25 yds.	30.0'	37 lbs.	10.0'/1
419 mm		533 mm	533 mm	419 mm	2.1 m	2.8 sqm	16.8 kg	.28 cu.

COM	COL	1	2	3	4	5	6	7	8	9	10	11
1019	1064	1229	1264	1284	1324	1359	1374	1399	1434	1464	1499	1699

neighborhood 6030M

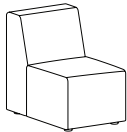

Mobile single-seat
Brushed aluminum handle
Fully upholstered
Saddle Stitched

Four casters

When using a combination of fabrics or leathers, specify the application by designating the appropriate letter, shown below, on the purchase order. Yardage shown must be used.

See terms and conditions for contrasting upholstery upcharges.

- A) One fabric or leather for seat
yardage: 2.75 yds. leather: 45.0 sq. ft.
- B) One fabric or leather for back and back side panels
yardage: 2.75 yds Leather: 45.0 sq. ft.

SCS Indoor Advantage™ Gold and LEVEL® 2 certified. See terms and conditions for iadditional environmental information.

Seat Height	Arm Height	W	D	H	Fabric	Leather	Weight	Cubes/Qty
16½"	-	21"	20"	28¾"	3.75 yds.	61.0'	66 lbs.	20.0'/1
419 mm	-	533 mm	797 mm	733 mm	3.4 m	5.7 sqm	29.9 kg	.57 cu.

COM	COL	1	2	3	4	5	6	7	8	9	10	11
1721	1796	2071	2130	2163	2230	2288	2313	2355	2413	2463	2521	2855

Freestanding

neighborhood 6030MJ



Mobile single-seat
Brushed aluminum handle
Fully upholstered
Jump master stitched

Four casters

When using a combination of fabrics or leathers, specify the application by designating the appropriate letter, shown below, on the purchase order. Yardage shown must be used.

See terms and conditions for contrasting upholstery upcharges.

- A) One fabric or leather for seat
yardage: 2.75 yds. leather: 45.0 sq. ft.
- B) One fabric or leather for back and back side panels
yardage: 2.75 yds. leather: 45.0 sq.ft.

SCS Indoor Advantage™ Gold and LEVEL® 2 certified. See terms and conditions for additional environmental information.

Jump Master Stitch Specification: Thread color must be specified. Reference Neighborhood/Stitching on BernhardtDesign.com for thread color options.

Seat Height	Arm Height	W	D	H	Fabric	Leather	Weight	Cubes/Qty
16½"	-	21"	31¾"	28¾"	3.75 yds.	61.0'	66 lbs.	20.0/1
419 mm		533 mm	797 mm	733 mm	3.4 m	5.7 sqm	29.9 kg	.57 cu.

COM	COL	1	2	3	4	5	6	7	8	9	10	11
1838	1913	2188	2247	2280	2347	2405	2430	2472	2530	2580	2638	2972

neighborhood 6024

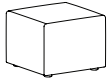

Single-seat ottoman
Fully upholstered
Saddle stitched

Non-marring adjustable glides

SCS Indoor Advantage™ Gold and LEVEL® 2 certified. See terms and conditions for additional environmental information.

Seat Height	Arm Height	W	D	H	Fabric	Leather	Weight	Cubes/Qty
16½"	-	21"	20"	16½"	2.25 yds.	30.0'	37 lbs.	10.0/1
419 mm	-	533 mm	533 mm	419 mm	2.1 m	2.8 sqm	16.8 kg	.28 cu.

COM	COL	1	2	3	4	5	6	7	8	9	10	11
862	907	1072	1107	1127	1167	1202	1217	1242	1277	1307	1342	1542

Freestanding

neighborhood 6024J

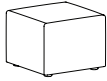

Single-seat ottoman
Fully upholstered
Jump master stitched

Non-marring adjustable glides

SCS Indoor Advantage™ Gold and LEVEL® 2 certified. See terms and conditions for additional environmental information.

Jump Master Stitch Specification: Thread color must be specified. Reference Neighborhood/Stitching on BernhardtDesign.com for thread color options.

Seat Height	Arm Height	W	D	H	Fabric	Leather	Weight	Cubes/Qty
16½"	-	21"	21"	16½"	2.25 yds.	30.0'	37 lbs.	10.0'/1
419 mm		533 mm	533 mm	419 mm	2.1 m	2.8 sqm	16.8 kg	.28 cu.

COM	COL	1	2	3	4	5	6	7	8	9	10	11
941	986	1151	1186	1206	1246	1281	1296	1321	1356	1386	1421	1621

neighborhood 6025

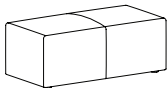

Two-seat bench
Fully upholstered
Saddle stitched

Non-marring adjustable glides

SCS Indoor Advantage™ Gold and LEVEL® 2 certified. See terms and conditions for additional environmental information.

Seat Height	Arm Height	W	D	H	Fabric	Leather	Weight	Cubes/Qty
16½"	-	41½"	21"	16½"	4.0 yds.	65.0'	51 lbs.	20.0'/1
419 mm	-	1054 mm	533 mm	419 mm	3.7 m	6.0 sqm	23.1 kg	.57 cu.

COM	COL	1	2	3	4	5	6	7	8	9	10	11
1332	1412	1706	1768	1804	1875	1937	1964	2008	2070	2124	2186	2541

neighborhood 6025J

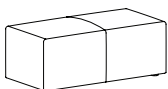

Two-seat Bench
Fully upholstered
Jump master stitched

Non-marring adjustable glides

SCS Indoor Advantage™ Gold and LEVEL® 2 certified. See terms and conditions for additional environmental information.

Jump Master Stitch Specification: Thread color must be specified. Reference Neighborhood/Stitching on BernhardtDesign.com for thread color options.

Seat Height	Arm Height	W	D	H	Fabric	Leather	Weight	Cubes/Qty
16½"	-	41½"	21"	16½"	4.0 yds.	65.0'	51 lbs.	20.0'/1
419 mm		1054 mm	533 mm	419 mm	3.7 m	6.0 sqm	23.1 kg	.57 cu.

COM	COL	1	2	3	4	5	6	7	8	9	10	11
1411	1491	1785	1847	1883	1954	2016	2043	2087	2149	2203	2265	2620

Freestanding

neighborhood 6027

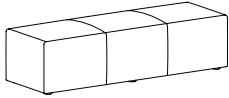

**Three-seat bench
Fully upholstered
Saddle stitched**

Non-marring adjustable glides

SCS Indoor Advantage™ Gold and LEVEL® 2 certified. See terms and conditions for additional environmental information.

Seat Height	Arm Height	W	D	H	Fabric	Leather	Weight	Cubes/Qty
16½"	-	62"	21"	16½"	6.0 yds.	100.0'	66 lbs.	25.0'/1
419 mm	-	1575 mm	533 mm	419 mm	5.5 m	9.3 sqm	29.9 kg	.71 cu.

COM	COL	1	2	3	4	5	6	7	8	9	10	11
1879	1999	2439	2533	2586	2693	2786	2826	2893	2986	3066	3159	3693

neighborhood 6027J

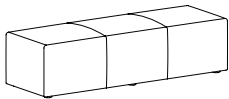

**Three-seat bench
Fully upholstered
Jump master stitched**

Non-marring adjustable glides

SCS Indoor Advantage™ Gold and LEVEL® 2 certified. See terms and conditions for additional environmental information.

Jump Master Stitch Specification: Thread color must be specified. Reference Neighborhood/Stitching on BernhardtDesign.com for thread color options.

Seat Height	Arm Height	W	D	H	Fabric	Leather	Weight	Cubes/Qty
16½"	-	62"	21"	16½"	6.0 yds.	100.0'	66 lbs.	25.0'/1
419 mm	-	1575 mm	533 mm	419 mm	5.5 m	9.3 sqm	29.9 kg	.71 cu.

COM	COL	1	2	3	4	5	6	7	8	9	10	11
1996	2116	2556	2650	2703	2810	2903	2943	3010	3103	3183	3276	3810

neighborhood 6021



**Round ottoman
Fully upholstered
Saddle stitched**

Non-marring adjustable glides

SCS Indoor Advantage™ Gold and LEVEL® 2 certified. See terms and conditions for additional environmental information.

Seat Height	Arm Height	W	D	H	Fabric	Leather	Weight	Cubes/Qty
16½"	-	21"	21"	16½"	1.75 yds.	24.0'	30 lbs.	10.0'/1
419 mm	-	533 mm	533 mm	419 mm	1.6 m	2.2 sqm	13.6 kg	.28 cu.

COM	COL	1	2	3	4	5	6	7	8	9	10	11
941	976	1105	1132	1148	1179	1206	1218	1237	1264	1288	1315	1470

Freestanding

neighborhood 6021J



Round ottoman
Fully upholstered
Jump master stitched

Non-marring adjustable glides

SCS Indoor Advantage™ Gold and LEVEL® 2 certified. See terms and conditions for additional environmental information.

Jump Master Stitch Specification: Thread color must be specified. Reference Neighborhood/Stitching on BernhardtDesign.com for thread color options.

Seat Height	Arm Height	W	D	H	Fabric	Leather	Weight	Cubes/Qty
16½"	-	21"	21"	16½"	1.75 yds.	24.0'	30 lbs.	10.0'/1
419 mm	-	533 mm	533 mm	419 mm	1.6 m	2.2 sqm	13.6 kg	.28 cu.

COM	COL	1	2	3	4	5	6	7	8	9	10	11
1019	1054	1183	1210	1226	1257	1284	1296	1315	1342	1366	1393	1548

neighborhood 6022

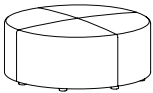

Large round Ottoman
Fully upholstered
Saddle stitched

Non-marring adjustable glides

SCS Indoor Advantage™ Gold and LEVEL® 2 certified. See terms and conditions for additional environmental information.

Seat Height	Arm Height	W	D	H	Fabric	Leather	Weight	Cubes/Qty
16½"	-	41"	41"	16½"	4.0 yds.	70.0'	79 lbs.	40.0'/1
419 mm	-	1041 mm	1041 mm	419 mm	3.7 m	6.5 sqm	35.9 kg	1.13 cu.

COM	COL	1	2	3	4	5	6	7	8	9	10	11
1879	1959	2253	2315	2351	2422	2484	2511	2555	2617	2671	2733	3088

neighborhood 6022J

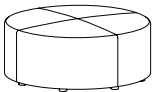

Large round Ottoman
Fully upholstered
Jump master stitched

Non-marring adjustable glides

SCS Indoor Advantage™ Gold and LEVEL® 2 certified. See terms and conditions for additional environmental information.

Jump Master Stitch Specification: Thread color must be specified. Reference Neighborhood/Stitching on BernhardtDesign.com for thread color options.

Seat Height	Arm Height	W	D	H	Fabric	Leather	Weight	Cubes/Qty
16½"	-	41"	41"	16½"	4.0 yds.	70.0'	79 lbs.	40.0'/1
419 mm	-	1041 mm	1041 mm	419 mm	3.7 m	6.5 sqm	35.9 kg	1.13 cu.

COM	COL	1	2	3	4	5	6	7	8	9	10	11
1996	2076	2370	2432	2468	2539	2601	2628	2672	2734	2788	2850	3205

Freestanding

neighborhood 6020

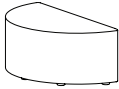

Half round ottoman
Fully upholstered
Saddle stitched

Non-marring adjustable glides

SCS Indoor Advantage™ Gold and LEVEL® 2 certified. See terms and conditions for additional environmental information.

Seat Height	Arm Height	W	D	H	Fabric	Leather	Weight	Cubes/Qty
16½"	-	41"	20½"	16½"	2.6 yds.	45.0'	41 lbs.	25.0'/1
419 mm	-	1041 mm	521 mm	419 mm	2.4 m	4.2 sqm	18.6 kg	.71 cu.

COM	COL	1	2	3	4	5	6	7	8	9	10	11
1175	1227	1418	1459	1482	1528	1568	1586	1615	1655	1690	1730	1961

neighborhood 6020J



Half round ottoman
Fully upholstered
Jump master stitched

Non-marring adjustable glides

SCS Indoor Advantage™ Gold and LEVEL® 2 certified. See terms and conditions for additional environmental information.

Jump Master Stitch Specification: Thread color must be specified. Reference Neighborhood/Stitching on BernhardtDesign.com for thread color options.

Seat Height	Arm Height	W	D	H	Fabric	Leather	Weight	Cubes/Qty
16½"	-	41"	20½"	16½"	2.6 yds.	45.0'	41 lbs.	25.0'/1
419 mm	-	1041 mm	521 mm	419 mm	2.4 m	4.2 sqm	18.6 kg	.71 cu.

COM	COL	1	2	3	4	5	6	7	8	9	10	11
1254	1306	1497	1538	1561	1607	1647	1665	1694	1734	1769	1809	2040

neighborhood 6019



Oval ottoman
Fully upholstered
Saddle stitched

Non-marring adjustable glides

SCS Indoor Advantage™ Gold and LEVEL® 2 certified. See terms and conditions for additional environmental information.

Seat Height	Arm Height	W	D	H	Fabric	Leather	Weight	Cubes/Qty
16½"	-	55½"	42"	16½"	3.5 yds.	60.0'	95 lbs.	45.0'/1
419 mm	-	410 mm	1067 mm	419 mm	3.2 m	5.6 sqm	43.1 kg	1.27 cu.

COM	COL	1	2	3	4	5	6	7	8	9	10	11
2190	2260	2517	2572	2603	2665	2719	2743	2782	2836	2883	2937	3248

Freestanding

neighborhood 6019J



Oval ottoman
Fully upholstered
Jump master stitched

Non-marring adjustable glides

SCS Indoor Advantage™ Gold and LEVEL® 2 certified. See terms and conditions for additional environmental information.

Jump Master Stitch Specification: Thread color must be specified. Reference Neighborhood/Stitching on BernhardtDesign.com for thread color options.

Seat Height	Arm Height	W	D	H	Fabric	Leather	Weight	Cubes/Qty
16½"	-	55½"	42"	16½"	3.5 yds.	60.0'	95 lbs.	45.0'/1
419 mm		410 mm	1067 mm	419 mm	3.2 m	5.6 sqm	43.1 kg	1.27 cu.

COM	COL	1	2	3	4	5	6	7	8	9	10	11
2307	2377	2634	2689	2720	2782	2836	2860	2899	2953	3000	3054	3365

neighborhood 6044

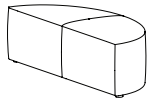

Half oval ottoman
Fully upholstered
Saddle stitched

Non-marring adjustable glides
Pivoting connectors

SCS Indoor Advantage™ Gold and LEVEL® 2 certified. See terms and conditions for additional environmental information.

Seat Height	Arm Height	W	D	H	Fabric	Leather	Weight	Cubes/Qty
16½"	-	56"	21½"	16 1/2"	3.5 yds.	60.0'	61 lbs.	20.0'/1
419 mm	-	1422 mm	546 mm	419 mm	3.2 m	5.6 sqm	27.7 kg	.57 cu.

COM	COL	1	2	3	4	5	6	7	8	9	10	11
1488	1558	1815	1870	1901	1963	2017	2041	2080	2134	2181	2235	2546

neighborhood 6044J

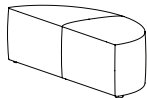

Half oval ottoman
Fully upholstered
Jump master stitched

Non-marring adjustable glides
Pivoting connectors

SCS Indoor Advantage™ Gold and LEVEL® 2 certified. See terms and conditions for additional environmental information.

Jump Mater Stitch Specification: Thread color must be specified. Reference Neighborhood/Stitching on BernhardtDesign.com for thread color options.

Seat Height	Arm Height	W	D	H	Fabric	Leather	Weight	Cubes/Qty
16½"	-	56"	21 1/2"	16½"	3.5 yds.	60.0'	61 lbs.	20.0'/1
419 mm	-	1422 mm	546 mm	419 mm	3.2 m	5.6 sqm	27.7 kg	.57 cu.

COM	COL	1	2	3	4	5	6	7	8	9	10	11
1565	1635	1892	1947	1978	2040	2094	2118	2157	2211	2258	2312	2623

Freestanding mid height work tables



22" round worksurface with 12½" round upholstered base.
 Worksurface available in oak veneer, laminate and corian.
 When specifying light finishes the natural characteristics of the wood will be visible and color will vary.
 Upholstered base with saddle stitch or jump master stitch. Jump master stitch specification: Thread color must be specified.
 Reference Neighborhood/Stitching on BernhardtDesign.com for color options.

Contact sales representative for approved Bernhardt Textiles for Neighborhood tables.

Worksurface Height	L	D	H	Fabric	Leather	Weight	Cubes/Qty
23¾"	22"	22"	23¾"	1.25 yds.	25.0'	95 lbs.	94.5/1
603 mm	559 mm	559 mm	603 mm	1.1 m	2.3 sqm	43.1 kg	2.7 cu.

neighborhood

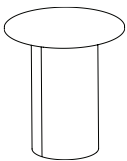

R1X Oak Worksurface. Saddle Stitch Upholstered Base

COM	COL	1	2	3	4	5	6	7	8	9	10	11
1721	1746	1838	1858	1869	1891	1910	1919	1933	1952	1969	1988	2099

Specify veneer code C for oak worksurface. Specify finish code.

R1X Laminate Worksurface. Saddle Stitch Upholstered Base

COM	COL	1	2	3	4	5	6	7	8	9	10	11
1879	1904	1996	2016	2027	2049	2068	2077	2091	2110	2127	2146	2257

Specify veneer code F for laminate designer white worksurface.

R1X Corian Worksurface. Saddle Stitch Upholstered Base

COM	COL	1	2	3	4	5	6	7	8	9	10	11
2190	2215	2307	2327	2338	2360	2379	2388	2402	2421	2438	2457	2568ss

Specify veneer code 8 for corian glacier white worksurface.

neighborhood

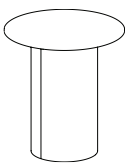

R1J Oak Worksurface. Jump Master Stitch Upholstered Base

COM	COL	1	2	3	4	5	6	7	8	9	10	11
1800	1825	1917	1937	1948	1970	1989	1998	2012	2031	2048	2067	2178

Specify veneer code C for oak worksurface. Specify finish code.

R1J Laminate Worksurface. Jump Master Stitch Upholstered Base

COM	COL	1	2	3	4	5	6	7	8	9	10	11
1957	1982	2074	2094	2105	2127	2146	2155	2169	2188	2205	2224	2335

Specify veneer code F for laminate designer white worksurface.

R1J Corian Worksurface. Jump Master Stitch Upholstered Base

COM	COL	1	2	3	4	5	6	7	8	9	10	11
2268	2293	2385	2405	2416	2438	2457	2466	2480	2499	2516	2535	2646

Specify veneer code 8 for corian glacier white worksurface.

series	sku	veneer	power finish	power	finish
J		C oak F laminate - designer white 8 corian - glacier white	X none	X none	
			X	X	

Freestanding mid height work tables



42" round worksurface with 19½" round upholstered base.
 Worksurface available in oak veneer, laminate and corian.
 When specifying light finishes the natural characteristics of the wood will be visible and color will vary.
 Upholstered base with saddle stitch or jump master stitch. Jump master stitch specification: Thread color must be specified.
 Reference Neighborhood/Stitching on BernhardtDesign.com for color options.

Contact sales representative for approved Bernhardt Textiles for Neighborhood tables.
 When power is specified, (1) 15 amp receptacle, (1) 2 amp USB-A port, 10 watt and (1) 2 amp USB-C port, 20 watt are provided.
 An upcharge of \$350 applies.

Worksurface Height	L	D	H	Fabric	Leather	Weight	Cubes/Qty
23¾"	42"	42"	23¾"	2.0 yds.	35.0'	235 lbs.	50.0/1
603 mm	1067 mm	1067 mm	603 mm	1.8 m	3.3sqm	106.8 kg	1.4 cu.

neighborhood

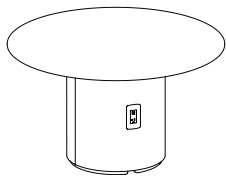

R2X Oak Worksurface. Saddle Stitch Upholstered Base

COM	COL	1	2	3	4	5	6	7	8	9	10	11
3715	3755	3902	3933	3951	3987	4018	4031	4053	4084	4111	4142	4320

Specify veneer code C for oak worksurface. Specify finish code. Add \$350 when specifying power.

R2X Laminate Worksurface. Saddle Stitch Upholstered Base

COM	COL	1	2	3	4	5	6	7	8	9	10	11
4024	4064	4211	4242	4260	4296	4327	4340	4362	4393	4420	4451	4629

Specify veneer code F for laminate designer white worksurface. Add \$350 when specifying power.

R2X Corian Worksurface. Saddle Stitch Upholstered Base

COM	COL	1	2	3	4	5	6	7	8	9	10	11
5742	5782	5929	5960	5978	6014	6045	6058	6080	6111	6138	6169	6347

Specify veneer code 8 for corian glacier white worksurface. Add \$350 when specifying power.

neighborhood

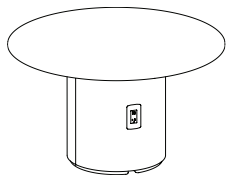

R2J Oak Worksurface. Jump Master Stitch Upholstered Base

COM	COL	1	2	3	4	5	6	7	8	9	10	11
3791	3831	3978	4009	4027	4063	4094	4107	4129	4160	4187	4218	4396

Specify veneer code C for oak worksurface. Specify finish code. Add \$350 when specifying power.

R2J Laminate Worksurface. Jump Master Stitch Upholstered Base

COM	COL	1	2	3	4	5	6	7	8	9	10	11
4103	4143	4290	4321	4339	4375	4406	4419	4441	4472	4499	4530	4708

Specify veneer code F for laminate designer white worksurface. Add \$350 when specifying power.

R2J Corian Worksurface. Jump Master Stitch Upholstered Base

COM	COL	1	2	3	4	5	6	7	8	9	10	11
5819	5859	6006	6037	6055	6091	6122	6135	6157	6188	6215	6246	6424

Specify veneer code 8 for corian glacier white worksurface. Add \$350 when specifying power.

series	sku	veneer	power finish	power	finish
J		C oak F laminate - designer white 8 corian - glacier white	4 aluminum powder coat X none	X none Q power + usb (1) upcharge \$350	

Single Sided Connecting Modules

neighborhood 6033

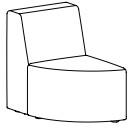

**Left end facing module
Fully upholstered
Saddle stitched**

Non-marring adjustable glides
Pivoting connectors

When using a combination of fabrics or leathers, specify the application by designating the appropriate letter, shown below, on the purchase order. Yardage shown must be used.

See terms and conditions for contrasting upholstery upcharges.

- A) One fabric or leather for seat
yardage: 2.25 yds. leather: 37.0 sq. ft.
- B) One fabric or leather for back and back side panels
yardage: 3.0 yds. leather: 50.0 sq. ft.

SCS Indoor Advantage™ Gold and LEVEL® 2 certified. See terms and conditions for additional environmental information.

Seat Height	Arm Height	W	D	H	Fabric	Leather	Weight	Cubes/Qty
16½"	-	21"	31¼"	28¾"	4.0 yds.	66.0'	60.0 lbs.	20.0'/1
419 mm	-	533 mm	794 mm	733 mm	3.7 m	6.1 sqm	27.2 kg	.57 cu.

COM	COL	1	2	3	4	5	6	7	8	9	10	11
1643	1723	2017	2079	2115	2186	2248	2275	2319	2381	2435	2497	2852

neighborhood 6033J



**Left end facing module
Fully upholstered
Jump master stitched**

Non-marring adjustable glides
Pivoting connectors

When using a combination of fabrics or leathers, specify the application by designating the appropriate letter, shown below, on the purchase order. Yardage shown must be used.

See terms and conditions for contrasting upholstery upcharges..

- A) One fabric or leather for seat
yardage: 2.25 yds. leather: 37.0 sq. ft.
- B) One fabric or leather for back and back side panels
yardage: 3.0 yds. leather: 50.0 sq. ft.

SCS Indoor Advantage™ Gold and LEVEL® 2 certified. See terms and conditions for additional environmental information.

Jump Master Stitch Specification: Thread color must be specified. Reference Neighborhood/Stitching on BernhardtDesign.com for thread color options.

Seat Height	Arm Height	W	D	H	Fabric	Leather	Weight	Cubes/Qty
16½"	-	21"	31¼"	28¾"	4.0 yds.	66.0'	60.0 lbs.	20.0'/1
419 mm		533 mm	794 mm	733 mm	3.7 m	6.1 sqm	27.2 kg	.57 cu.

COM	COL	1	2	3	4	5	6	7	8	9	10	11
1761	1841	2135	2197	2233	2304	2366	2393	2437	2499	2553	2615	2970

Single Sided Connecting Modules

neighborhood 6034

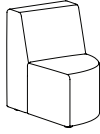

**Right end facing module
Fully upholstered
Saddle stitched**

Non-marring adjustable glides
Pivoting connectors

When using a combination of fabrics or leathers, specify the application by designating the appropriate letter, shown below, on the purchase order. Yardage shown must be used.

See terms and conditions for contrasting upholstery upcharges.

- A) One fabric or leather for seat
yardage: 2.25 yds. leather: 37.0 sq. ft.
- B) One fabric or leather for back and back side panels
yardage: 3.0 yds. leather: 50.0 sq. ft.

SCS Indoor Advantage™ Gold and LEVEL® 2 certified. See terms and conditions for additional environmental information.

Seat Height	Arm Height	W	D	H	Fabric	Leather	Weight	Cubes/Qty
16½"	-	21"	31¼"	28¾"	4.0 yds.	66.0'	60.0 lbs.	20.0'/1
419 mm	-	533 mm	794 mm	733 mm	3.7 m	6.1 sqm	27.2 kg	.57 cu.

COM	COL	1	2	3	4	5	6	7	8	9	10	11
1643	1723	2017	2079	2115	2186	2248	2275	2319	2381	2435	2497	2852

neighborhood 6034J

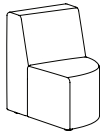

**Right end facing module
Fully upholstered
Jump master stitched**

Non-marring adjustable glides
Pivoting connectors

When using a combination of fabrics or leathers, specify the application by designating the appropriate letter, shown below, on the purchase order. Yardage shown must be used.

See terms and conditions for contrasting upholstery upcharges.

- A) One fabric or leather for seat
yardage: 2.25 yds. leather: 37.0 sq. ft.
- B) One fabric or leather for back and back side panels
yardage: 3.0 yds. leather: 50.0 sq. ft.

SCS Indoor Advantage™ Gold and LEVEL® 2 certified. See terms and conditions for additional environmental information.

Jump Master Stitch Specification: Thread color must be specified. Reference Neighborhood/Stitching on BernhardtDesign.com for thread color options.

Seat Height	Arm Height	W	D	H	Fabric	Leather	Weight	Cubes/Qty
16½"	-	21"	31¼"	28¾"	4.0 yds.	66.0'	60.0 lbs.	20.0'/1
419 mm		533 mm	794 mm	733 mm	3.7 m	6.1 sqm	27.2 kg	.57 cu.

COM	COL	1	2	3	4	5	6	7	8	9	10	11
1761	1841	2135	2197	2233	2304	2366	2393	2437	2499	2553	2615	2970

Single Sided Connecting Modules

neighborhood 6031

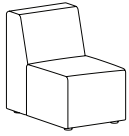

Straight connector
Fully upholstered
Saddle stitched

Non-marring adjustable glides
Pivoting connectors

When using a combination of fabrics or leathers, specify the application by designating the appropriate letter, shown below, on the purchase order. Yardage shown must be used.

See terms and conditions for contrasting upholstery upcharges.

- A) One fabric or leather for seat
yardage: 2.75 yds. leather: 45.0 sq. ft.
- B) One fabric or leather for back and back side panels
yardage: 2.75 yds. leather: 45.0 sq. ft.

SCS Indoor Advantage™ Gold and LEVEL® 2 certified. See terms and conditions for additional environmental information.

Seat Height	Arm Height	W	D	H	Fabric	Leather	Weight	Cubes/Qty
16½"	-	21"	31¼"	28¾"	3.75 yds.	61.0'	55 lbs.	20.0'/1
419 mm	-	533 mm	794 mm	733 mm	3.4 m	5.7 sqm	24.9 kg	.57 cu.

COM	COL	1	2	3	4	5	6	7	8	9	10	11
1643	1718	1993	2052	2085	2152	2210	2235	2277	2335	2385	2443	2777

neighborhood 6031J

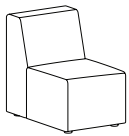

Straight connector
Fully upholstered
Jump master stitched

Non-marring adjustable glides
Pivoting connectors

When using a combination of fabrics or leathers, specify the application by designating the appropriate letter, shown below, on the purchase order. Yardage shown must be used.

See terms and conditions for contrasting upholstery upcharges.

- A) One fabric or leather for seat
yardage: 2.75 yds. leather: 45.0 sq. ft.
- B) One fabric or leather for back and back side panels
yardage: 2.75 yds. leather: 45.0 sq. ft.

SCS Indoor Advantage™ Gold and LEVEL® 2 certified. See terms and conditions for additional environmental information.

Jump Master Stitch Specification: Thread color must be specified. Reference Neighborhood/Stitching on BernhardtDesign.com for thread color options.

Seat Height	Arm Height	W	D	H	Fabric	Leather	Weight	Cubes/Qty
16½"	-	21"	31¼"	28¾"	3.75 yds.	61.0'	55 lbs.	20.0'/1
419 mm		533 mm	794 mm	733 mm	3.4 m	5.7 sqm	24.9 kg	.57 cu.

COM	COL	1	2	3	4	5	6	7	8	9	10	11
1761	1836	2111	2170	2203	2270	2328	2353	2395	2453	2503	2561	2895

Single Sided Connecting Modules

neighborhood 6035

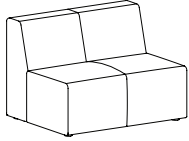

**Two-seat
Straight connector
Fully upholstered
Saddle stitched**

Non-marring adjustable glides
Pivoting connectors

When using a combination of fabrics or leathers, specify the application by designating the appropriate letter, shown below, on the purchase order. Yardage shown must be used.

See terms and conditions for contrasting upholstery upcharges.

- A) One fabric or leather for seat
yardage: 3.75 yds. leather: 61.0 sq. ft.
- B) One fabric or leather for back and back side panels
yardage: 3.5 yds. leather: 58.0 sq. ft.

SCS Indoor Advantage™ Gold and LEVEL® 2 certified. See terms and conditions for additional environmental information.

Seat Height	Arm Height	W	D	H	Fabric	Leather	Weight	Cubes/Qty
16½"	-	41½"	31¾"	28¾"	6.0 yds.	96.0'	112 lbs.	36.75'/1
419 mm	-	1054 mm	794 mm	733 mm	5.5 m	8.9 sqm	50.8 kg	1.04 cu.

COM	COL	1	2	3	4	5	6	7	8	9	10	11
2503	2623	3063	3157	3210	3317	3410	3450	3517	3610	3690	3783	4317

neighborhood 6035J

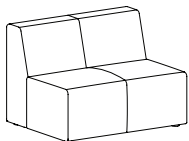

**Two-seat
Straight connector
Fully upholstered
Jump master stitched**

Non-marring adjustable glides
Pivoting connectors

When using a combination of fabrics or leathers, specify the application by designating the appropriate letter, shown below, on the purchase order. Yardage shown must be used.

See terms and conditions for contrasting upholstery upcharges.

- A) One fabric or leather for seat
yardage: 3.75 yds. leather: 61.0 sq. ft.
- B) One fabric or leather for back and back side panels
yardage: 3.5 yds. leather: 58.0 sq. ft.

SCS Indoor Advantage™ Gold and LEVEL® 2 certified. See terms and conditions for additional environmental information.

Jump Master Stitch Specification: Thread color must be specified. Reference Neighborhood/Stitching on BernhardtDesign.com for thread color options.

Seat Height	Arm Height	W	D	H	Fabric	Leather	Weight	Cubes/Qty
16½"	-	41½"	31¾"	28¾"	6.0 yds.	96.0'	112 lbs.	36.75'/1
419 mm	-	1054 mm	794 mm	733 mm	5.5 m	8.9 sqm	50.8 kg	1.04 cu.

COM	COL	1	2	3	4	5	6	7	8	9	10	11
2660	2780	3220	3314	3367	3474	3567	3607	3674	3767	3847	3940	4474

Single Sided Connecting Modules

neighborhood 6038

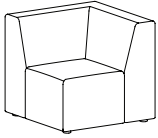

**90° Corner connector
Fully upholstered
Saddle stitched**

Non-marring adjustable glides
Pivoting connectors

When using a combination of fabrics or leathers, specify the application by designating the appropriate letter, shown below, on the purchase order. Yardage shown must be used.

See terms and conditions for contrasting upholstery upcharges.

- A) One fabric or leather for seat
yardage: 2.75 yds. leather: 45.0 sq. ft.
- B) One fabric or leather for back and back side panels
yardage: 4.5 yds. leather: 73.0 sq. ft.

SCS Indoor Advantage™ Gold and LEVEL® 2 certified. See terms and conditions for additional environmental information.

Seat Height	Arm Height	W	D	H	Fabric	Leather	Weight	Cubes/Qty
16½"	-	43¾"	43¾"	28¾"	7.25 yds.	125.0'	86 lbs.	36.75/1
419 mm	-	1102 mm	1092 mm	733 mm	6.6 m	11.6 sqm	39.0 kg	1.04 cu.

COM	COL	1	2	3	4	5	6	7	8	9	10	11
2034	2179	2711	2824	2888	3017	3130	3178	3259	3372	3468	3581	4226

neighborhood 6038J

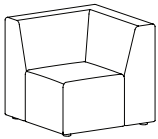

**90° Corner connector
Fully upholstered
Jump master stitched**

Non-marring adjustable glides
Pivoting connectors

When using a combination of fabrics or leathers, specify the application by designating the appropriate letter, shown below, on the purchase order. Yardage shown must be used.

See terms and conditions for contrasting upholstery upcharges.

- A) One fabric or leather for seat
yardage: 2.75 yds. leather: 45.0 sq. ft.
- B) One fabric or leather for back and back side panels
yardage: 4.5 yds. leather: 73.0 sq. ft.

SCS Indoor Advantage™ Gold and LEVEL® 2 certified. See terms and conditions for additional environmental information.

Jump Master Stitch Specification: Thread color must be specified. Reference Neighborhood/Stitching on BernhardtDesign.com for thread color options.

Seat Height	Arm Height	W	D	H	Fabric	Leather	Weight	Cubes/Qty
16½"	-	43¾"	43¾"	28¾"	7.25 yds.	125.0'	86 lbs.	36.75/1
419 mm		1102 mm	1092 mm	733 mm	6.6 m	11.6 sqm	39.0 kg	1.04 cu.

COM	COL	1	2	3	4	5	6	7	8	9	10	11
2190	2335	2867	2980	3044	3173	3286	3334	3415	3528	3624	3737	4382

Single Sided Connecting Modules

neighborhood 6039

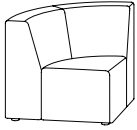

**90° Curved connector
Fully upholstered
Saddle stitched**

Non-marring adjustable glides
Pivoting connectors

When using a combination of fabrics or leathers, specify the application by designating the appropriate letter, shown below, on the purchase order. Yardage shown must be used.

See terms and conditions for contrasting upholstery upcharges.

- A) One fabric or leather for seat
yardage: 2.25 yds. leather: 37.0 sq. ft.
- B) One fabric or leather for back and back side panels
yardage: 3.75 yds. leather: 61.0 sq. ft.

SCS Indoor Advantage™ Gold and LEVEL® 2 certified. See terms and conditions for additional environmental information.

Seat Height	Arm Height	W	D	H	Fabric	Leather	Weight	Cubes/Qty
16½"	-	43¾"	43¾"	28¾"	6.75 yds.	115.0'	62 lbs.	36.75/1
419 mm	-	1102 mm	781 mm	733 mm	6.2 m	10.7 sqm	28.1 kg	1.04 cu.

COM	COL	1	2	3	4	5	6	7	8	9	10	11
2034	2169	2664	2769	2829	2949	3054	3099	3174	3279	3369	3474	4074

neighborhood 6039J

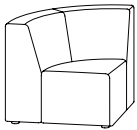

**90° Curved connector
Fully upholstered
Jump master stitched**

Non-marring adjustable glides
Pivoting connectors

When using a combination of fabrics or leathers, specify the application by designating the appropriate letter, shown below, on the purchase order. Yardage shown must be used.

See terms and conditions for contrasting upholstery upcharges.

- A) One fabric or leather for seat
yardage: 2.25 yds. leather: 37.0 sq. ft.
- B) One fabric or leather for back and back side panels
yardage: 3.75 yds. leather: 61.0 sq. ft.

SCS Indoor Advantage™ Gold and LEVEL® 2 certified. See terms and conditions for additional environmental information.

Jump Master Stitch Specification: Thread color must be specified. Reference Neighborhood/Stitching on BernhardtDesign.com for thread color options.

Seat Height	Arm Height	W	D	H	Fabric	Leather	Weight	Cubes/Qty
16½"	-	43¾"	43¾"	28¾"	6.75 yds.	115.0'	62 lbs.	36.75/1
419 mm		1102 mm	781 mm	733 mm	6.2 m	10.7 sqm	28.1 kg	1.04 cu.

COM	COL	1	2	3	4	5	6	7	8	9	10	11
2190	2325	2820	2925	2985	3105	3210	3255	3330	3435	3525	3630	4230

Single Sided Connecting Modules

neighborhood 6040



**45° Inverted curved connector
Fully upholstered
Saddle stitched**

Non-marring adjustable glides
Pivoting connectors

When using a combination of fabrics or leathers, specify the application by designating the appropriate letter, shown below, on the purchase order. Yardage shown must be used.

See terms and conditions for contrasting upholstery upcharges.

- A) One fabric or leather for seat
yardage: 3.25 yds. leather: 53.0 sq. ft.
- B) One fabric or leather for back and back side panels
yardage: 2.25 yds. leather: 37.0sq. ft.

SCS Indoor Advantage™ Gold and LEVEL® 2 certified. See terms and conditions for additional environmental information.

Seat Height	Arm Height	W	D	H	Fabric	Leather	Weight	Cubes/Qty
16½"	-	31¼"	31½"	28¾"	4.0 yds.	70.0'	70 lbs.	42.0'/1
419 mm	-	794 mm	800 mm	733 mm	3.7 m	6.5 sqm	31.8 kg	1.19 cu.

COM	COL	1	2	3	4	5	6	7	8	9	10	11
1879	1959	2253	2315	2351	2422	2484	2511	2555	2617	2671	2733	3088

neighborhood 6040J

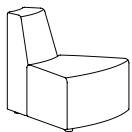

**45° Inverted curved connector
Fully upholstered
Jump master stitched**

Non-marring adjustable glides
Pivoting connectors

When using a combination of fabrics or leathers, specify the application by designating the appropriate letter, shown below, on the purchase order. Yardage shown must be used.

See terms and conditions for contrasting upholstery upcharges.

- A) One fabric or leather for seat
yardage: 3.25 yds. leather: 53.0 sq. ft.
- B) One fabric or leather for back and back side panels
yardage: 2.25 yds. leather: 37.0 sq. ft.

SCS Indoor Advantage™ Gold and LEVEL® 2 certified. See terms and conditions for additional environmental information.

Jump Master Stitch Specification: Thread color must be specified. Reference Neighborhood/Stitching on BernhardtDesign.com for thread color options.

Seat Height	Arm Height	W	D	H	Fabric	Leather	Weight	Cubes/Qty
16½"	-	31¼"	31½"	28¾"	4.0 yds.	70.0'	70 lbs.	42.0'/1
419 mm		794 mm	800 mm	733 mm	3.7 m	6.5 sqm	31.8 kg	1.19 cu.

COM	COL	1	2	3	4	5	6	7	8	9	10	11
1996	2076	2370	2432	2468	2539	2601	2628	2672	2734	2788	2850	3205

Single Sided Connecting Modules

neighborhood 6041

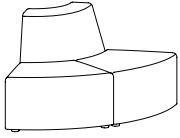

90° Inverted curved connector
Fully upholstered
Saddle Stitched

Non-marring adjustable glides
Pivoting connectors

When using a combination of fabrics or leathers, specify the application by designating the appropriate letter, shown below, on the purchase order. Yardage shown must be used.

See terms and conditions for contrasting upholstery upcharges..

- A) One fabric or leather for seat
yardage: 4.25 yds. leather: 69.0 sq. ft.
- B) One fabric or leather for back and back side panels
yardage: 2.75 yds. leather: 45.0 sq. ft.

SCS Indoor Advantage™ Gold and LEVEL® 2 certified. See terms and conditions for additional environmental information.

Seat Height	Arm Height	W	D	H	Fabric	Leather	Weight	Cubes/Qty
16½"	-	57¾"	33½"	28¾"	6.0 yds.	97.0'	86 lbs.	90.0'/1
419 mm	-	1467 mm	851mm	733 mm	5.5 m	9.0 sqm	39.0 kg	2.55 cu.

COM	COL	1	2	3	4	5	6	7	8	9	10	11
2815	2935	3375	3469	3522	3629	3722	3762	3829	3922	4002	4095	4629

neighborhood 6041J

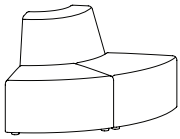

90° Inverted curved connector
Fully upholstered
Jump master stitched

Non-marring adjustable glides
Pivoting connectors

When using a combination of fabrics or leathers, specify the application by designating the appropriate letter, shown below, on the purchase order. Yardage shown must be used.

See terms and conditions for contrasting upholstery upcharges.

- A) One fabric or leather for seat
yardage: 4.25 yds. leather: 69.0 sq. ft.
- B) One fabric or leather for back and back side panels
yardage: 2.75 yds. leather: 45.0 sq. ft.

SCS Indoor Advantage™ Gold and LEVEL® 2 certified. See terms and conditions for additional environmental information.

Jump Master Stitch Specification: Thread color must be specified. Reference Neighborhood/Stitching on BernhardtDesign.com for thread color options.

Seat Height	Arm Height	W	D	H	Fabric	Leather	Weight	Cubes/Qty
16½"	-	57¾"	33½"	28¾"	7.25 yds.	125.0'	86 lbs.	90.0'/1
419 mm		1467 mm	851mm	733 mm	6.6 m	11.6 sqm	39.0 kg	2.55 cu.

COM	COL	1	2	3	4	5	6	7	8	9	10	11
2970	3090	3530	3624	3677	3784	3877	3917	3984	4077	4157	4250	4784

Single Sided Connecting Modules

neighborhood 6048

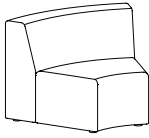

**45° Curved connector
Fully upholstered
Saddle stitched**

Non-marring adjustable glides
Pivoting connectors

When using a combination of fabrics or leathers, specify the application by designating the appropriate letter, shown below, on the purchase order. Yardage shown must be used.

See terms and conditions for contrasting upholstery upcharges.

- A) One fabric or leather for seat
yardage: 2.75 yds. leather: 45.0 sq. ft.
- B) One fabric or leather for back and back side panels
yardage: 3.25 yds. leather: 53.0 sq. ft.

SCS Indoor Advantage™ Gold and LEVEL® 2 certified. See terms and conditions for additional environmental information.

Seat Height	Arm Height	W	D	H	Fabric	Leather	Weight	Cubes/Qty
16½"	-	41⅝"	32⅝"	28⅞"	5.5 yds.	90.0'	97 lbs.	54.0'/1
419 mm	-	1051 mm	829 mm	733 mm	5.1 m	8.4 sqm	44.0 kg	1.53 cu.

COM	COL	1	2	3	4	5	6	7	8	9	10	11
2034	2146	2557	2644	2694	2794	2881	2918	2980	3067	3142	3229	3727

neighborhood 6048J

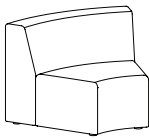

**45° Curved connector
Fully upholstered
Jump master stitched**

Non-marring adjustable glides
Pivoting connectors

When using a combination of fabrics or leathers, specify the application by designating the appropriate letter, shown below, on the purchase order. Yardage shown must be used.

See terms and conditions for contrasting upholstery upcharges.

- A) One fabric or leather for seat
yardage: 2.75 yds. leather: 45.0 sq. ft.
- B) One fabric or leather for back and back side panels
yardage: 3.25 yds. leather: 53.0 sq. ft.

SCS Indoor Advantage™ Gold and LEVEL® 2 certified. See terms and conditions for additional environmental information.

Jump Master Stitch Specification: Thread color must be specified. Reference Neighborhood/Stitching on BernhardtDesign.com for thread color options.

Seat Height	Arm Height	W	D	H	Fabric	Leather	Weight	Cubes/Qty
16½"	-	41⅝"	32⅝"	28⅞"	5.5 yds.	90.0'	97 lbs.	54.0'/1
419 mm	-	1051 mm	829 mm	733 mm	5.1 m	8.4 sqm	44.0 kg	1.53 cu.

COM	COL	1	2	3	4	5	6	7	8	9	10	11
2152	2264	2675	2762	2812	2912	2999	3036	3098	3185	3260	3347	3845

Single Sided Connecting Modules

neighborhood 6049

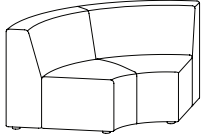

**90° Curved connector
Fully upholstered
Saddle stitched**

Non-marring adjustable glides
Pivoting connectors

When using a combination of fabrics or leathers, specify the application by designating the appropriate letter, shown below, on the purchase order. Yardage shown must be used.

See terms and conditions for contrasting upholstery upcharges.

- A) One fabric or leather for seat
yardage: 3.75 yds. leather: 61.0 sq. ft.
- B) One fabric or leather for back and back side panels
yardage: 5.5 yds. leather: 88.0 sq. ft.

SCS Indoor Advantage™ Gold and LEVEL® 2 certified. See terms and conditions for additional environmental information.

Seat Height	Arm Height	W	D	H	Fabric	Leather	Weight	Cubes/Qty
16½"	-	65½"	35¼"	28¾"	7.5 yds.	120.0'	149 lbs.	108.0/1
419 mm	-	1654 mm	889 mm	733 mm	6.9 m	11.1 sqm	67.5 kg	3.06 cu.

COM	COL	1	2	3	4	5	6	7	8	9	10	11
2815	2965	3515	3632	3699	3832	3949	3999	4082	4199	4299	4415	5082

neighborhood 6049J

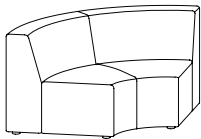

**90° Curved connector
Fully upholstered
Jump master stitched**

Non-marring adjustable glides
Pivoting connectors

When using a combination of fabrics or leathers, specify the application by designating the appropriate letter, shown below, on the purchase order. Yardage shown must be used.

See terms and conditions for contrasting upholstery upcharges.

- A) One fabric or leather for seat
yardage: 3.75 yds. leather: 61.0 sq. ft.
- B) One fabric or leather for back and back side panels
yardage: 5.5 yds. leather: 88.0 sq. ft.

SCS Indoor Advantage™ Gold and LEVEL® 2 certified. See terms and conditions for additional environmental information.

Jump Master Stitch Specification: Thread color must be specified. Reference Neighborhood/Stitching on BernhardtDesign.com for thread color options.

Seat Height	Arm Height	W	D	H	Fabric	Leather	Weight	Cubes/Qty
16½"	-	65½"	35¼"	28¾"	7.5 yds.	120.0'	149 lbs.	108.0/1
419 mm		1654 mm	889 mm	733 mm	6.9 m	11.1 sqm	67.5 kg	3.06 cu.

COM	COL	1	2	3	4	5	6	7	8	9	10	11
2970	3120	3670	3787	3854	3987	4104	4154	4237	4354	4454	4570	5237

Double Sided Connecting Modules

neighborhood 6045

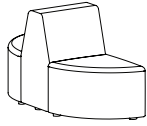

**Double-sided
Curved end module
Fully upholstered
Saddle stitched**

Non-marring adjustable glides
Pivoting connectors

When using a combination of fabrics or leathers, specify the application by designating the appropriate letter, shown below, on the purchase order. Yardage shown must be used.

See terms and conditions for contrasting upholstery upcharges.

- A) One fabric or leather for seat
yardage: 4.0 yds. leather: 65.0 sq. ft.
- B) One fabric or leather for back and back side panels
yardage: 3.0 yds. leather: 50.0 sq. ft.

SCS Indoor Advantage™ Gold and LEVEL® 2 certified. See terms and conditions for additional environmental information.

Seat Height	Arm Height	W	D	H	Fabric	Leather	Weight	Cubes/Qty
16½"	-	21"	56"	28¾"	4.75 yds.	66.0'	86 lbs.	30.0'/1
419 mm	-	533 mm	1422 mm	733 mm	4.3 m	6.1 sqm	39.0 kg	.85 cu.

COM	COL	1	2	3	4	5	6	7	8	9	10	11
2580	2675	3024	3098	3140	3224	3298	3330	3383	3457	3520	3594	4016

neighborhood 6045J

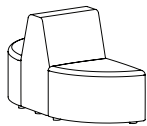

**Double-sided
Curved end module
Fully upholstered
Jump master stitched**

Non-marring adjustable glides
Pivoting connectors

When using a combination of fabrics or leathers, specify the application by designating the appropriate letter, shown below, on the purchase order. Yardage shown must be used.

See terms and conditions for contrasting upholstery upcharges.

- A) One fabric or leather for seat
yardage: 4.0 yds. leather: 65.0 sq. ft.
- B) One fabric or leather for back and back side panels
yardage: 3.0 yds. leather: 50.0 sq. ft.

SCS Indoor Advantage™ Gold and LEVEL® 2 certified. See terms and conditions for additional environmental information.

Jump Master Stitch Specification: Thread color must be specified. Reference Neighborhood/Stitching on BernhardtDesign.com for thread color options.

Seat Height	Arm Height	W	D	H	Fabric	Leather	Weight	Cubes/Qty
16½"	-	21"	56"	28¾"	4.75 yds.	66.0'	86 lbs.	30.0'/1
419 mm	-	533 mm	1422 mm	733 mm	4.3 m	6.1 sqm	39.0 kg	.85 cu.

COM	COL	1	2	3	4	5	6	7	8	9	10	11
2775	2870	3219	3293	3335	3419	3493	3525	3578	3652	3715	3789	4211

Double Sided Connecting Modules

neighborhood 6042

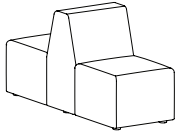

**Double-sided single-seat
Straight connector
Fully upholstered
Saddle stitched**

Non-marring adjustable glides
Pivoting connectors

When using a combination of fabrics or leathers, specify the application by designating the appropriate letter, shown below, on the purchase order. Yardage shown must be used.

See terms and conditions for contrasting upholstery upcharges.

- A) One fabric or leather for seat
yardage: 4.25 yds. leather: 69.0 sq. ft.
- B) One fabric or leather for back and back side panels
yardage: 3.0 yds. leather: 50.0 sq. ft.

SCS Indoor Advantage™ Gold and LEVEL® 2 certified. See terms and conditions for additional environmental information.

Seat Height	Arm Height	W	D	H	Fabric	Leather	Weight	Cubes/Qty
16½"	-	21"	56"	28¾"	6.0 yds.	60.0'	50 lbs.	30.0'/1
419 mm	-	533 mm	1422 mm	733 mm	5.5 m	4.6 sqm	22.7 kg	.85 cu.

COM	COL	1	2	3	4	5	6	7	8	9	10	11
2580	2700	3140	3234	3287	3394	3487	3527	3594	3687	3767	3860	4394

neighborhood 6042J

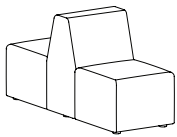

**Double-sided single-seat
Straight connector
Fully upholstered
Jump master stitched**

Non-marring adjustable glides
Pivoting connectors

When using a combination of fabrics or leathers, specify the application by designating the appropriate letter, shown below, on the purchase order. Yardage shown must be used.

See terms and conditions for contrasting upholstery upcharges.

- A) One fabric or leather for seat
yardage: 4.25 yds. leather: 69.0 sq. ft.
- B) One fabric or leather for back and back side panels
yardage: 3.0 yds. leather: 50.0 sq. ft.

SCS Indoor Advantage™ Gold and LEVEL® 2 certified. See terms and conditions for additional environmental information.

Jump Master Stitch Specification: Thread color must be specified. Reference Neighborhood/Stitching on BernhardtDesign.com for thread color options.

Seat Height	Arm Height	W	D	H	Fabric	Leather	Weight	Cubes/Qty
16½"	-	21"	56"	28¾"	6.0 yds.	60.0'	50 lbs.	30.0'/1
419 mm	-	533 mm	1422 mm	733 mm	5.5 m	4.6 sqm	22.7 kg	.85 cu.

COM	COL	1	2	3	4	5	6	7	8	9	10	11
2775	2895	3335	3429	3482	3589	3682	3722	3789	3882	3962	4055	4589

Double Sided Connecting Modules

neighborhood 6043

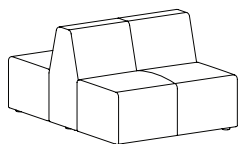

**Double-sided two-seat
Straight connector
Fully upholstered
Saddle stitched**

Non-marring adjustable glides
Pivoting connectors

When using a combination of fabrics or leathers, specify the application by designating the appropriate letter, shown below, on the purchase order. Yardage shown must be used.

See terms and conditions for contrasting upholstery upcharges.

- A) One fabric or leather for seat
yardage: 5.75 yds. leather: 93.0 sq. ft.
- B) One fabric or leather for back and back side panels
yardage: 4.5 yds. leather: 73.0 sq. ft.

SCS Indoor Advantage™ Gold and LEVEL® 2 certified. See terms and conditions for additional environmental information.

Seat Height	Arm Height	W	D	H	Fabric	Leather	Weight	Cubes/Qty
16½"	-	41½"	56"	28½"	8.5 yds.	138.0'	134 lbs.	60.0'/1
419 mm	-	1054 mm	1422 mm	733 mm	7.8 m	12.8 sqm	60.8 kg	1.70 cu.

COM	COL	1	2	3	4	5	6	7	8	9	10	11
3752	3922	4546	4678	4754	4905	5037	5094	5188	5320	5434	5566	6321

neighborhood 6043J

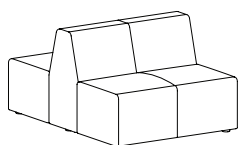

**Double-sided two-seat
Straight connector
Fully upholstered
Jump master stitched**

Non-marring adjustable glides
Pivoting connectors

When using a combination of fabrics or leathers, specify the application by designating the appropriate letter, shown below, on the purchase order. Yardage shown must be used.

See terms and conditions for contrasting upholstery upcharges.

- A) One fabric or leather for seat
yardage: 5.75 yds. leather: 93.0 sq. ft.
- B) One fabric or leather for back and back side panels
yardage: 4.5 yds. leather: 73.0 sq. ft.

SCS Indoor Advantage™ Gold and LEVEL® 2 certified. See terms and conditions for additional environmental information.

Jump Master Stitch Specification: Thread color must be specified. Reference Neighborhood/Stitching on BernhardtDesign.com for thread color options.

Seat Height	Arm Height	W	D	H	Fabric	Leather	Weight	Cubes/Qty
16½"	-	41½"	56"	28½"	8.5 yds.	138.0'	134 lbs.	60.0'/1
419 mm	-	1054 mm	1422 mm	733 mm	7.8 m	12.8 sqm	60.8 kg	1.70 cu.

COM	COL	1	2	3	4	5	6	7	8	9	10	11
4064	4234	4858	4990	5066	5217	5349	5406	5500	5632	5746	5878	6633

Double Sided Connecting Modules

neighborhood 6046

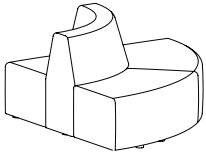

Double-sided
90° Curved connector
Fully upholstered
Saddle stitched

Non-marring adjustable glides
Pivoting connectors

When using a combination of fabrics or leathers, specify the application by designating the appropriate letter, shown below, on the purchase order. Yardage shown must be used.

See terms and conditions for contrasting upholstery upcharges.

- A) One fabric or leather for seat
yardage: 6.75 yds. leather: 110.0 sq. ft.
- B) One fabric or leather for back and back side panels
yardage: 4.0 yds. leather: 65.0 sq. ft.

SCS Indoor Advantage™ Gold and LEVEL® 2 certified. See terms and conditions for additional environmental information.

Seat Height	Arm Height	W	D	H	Fabric	Leather	Weight	Cubes/Qty
16½"	-	78½"	56"	28½"	9.5 yds.	154.0'	160.6 lbs.	149.3'/1
419 mm	-	1997 mm	1422 mm	733 mm	8.7 m	14.3 sqm	72.8 kg	4.23 cu.

COM	COL	1	2	3	4	5	6	7	8	9	10	11
3908	4098	4795	4943	5027	5196	5344	5407	5513	5661	5787	5935	6780

neighborhood 6046J

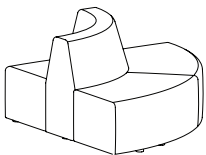

Double-sided
90° Curved connector
Fully upholstered
Jump master stitched

Non-marring adjustable glides
Pivoting connectors

When ordering multi-item configurations, please provide the total COM yardage from the same dye lot in a continuous roll(s).

When using a combination of fabrics or leathers, the following yardage must be used and upcharges apply. Please specify the fabric or leather application by designating the appropriate letter on the purchase order.

See terms and conditions for contrasting fabric upcharges.

- A) One fabric or leather for seat
yardage: 6.75 yds. leather: 110.0 sq. ft.
- B) One fabric or leather for back and back side panels
yardage: 4.0 yds. leather: 65.0 sq. ft.

SCS Indoor Advantage™ Gold and LEVEL® 2 certified. See terms and conditions for additional environmental information.

Jump Master Stitch Specification: Thread color must be specified. Reference Neighborhood/Stitching on BernhardtDesign.com for thread color options. options.

Seat Height	Arm Height	W	D	H	Fabric	Leather	Weight	Cubes/Qty
16½"	-	78½"	56"	28½"	9.5 yds.	154.0'	160.6 lbs.	149.3'/1
419 mm	-	1997 mm	1422 mm	733 mm	8.7 m	14.3 sqm	72.8 kg	4.23 cu.

COM	COL	1	2	3	4	5	6	7	8	9	10	11
4221	4411	5108	5256	5340	5509	5657	5720	5826	5974	6100	6248	7093

Double Sided Connecting Modules

neighborhood 6044

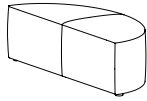

Half oval ottoman
Fully upholstered
Saddle stitched

Non-marring adjustable glides
Pivoting connectors

SCS Indoor Advantage™ Gold and LEVEL® 2 certified. See terms and conditions for additional environmental information.

Seat Height	Arm Height	W	D	H	Fabric	Leather	Weight	Cubes/Qty
16½"	-	56"	21½"	16½"	3.5 yds.	60.0'	61 lbs.	20.0'/1
419 mm	-	1422 mm	546 mm	419 mm	3.2 m	5.6 sqm	27.7 kg	.57 cu.

COM	COL	1	2	3	4	5	6	7	8	9	10	11
1488	1558	1815	1870	1901	1963	2017	2041	2080	2134	2181	2235	2546

neighborhood 6044J

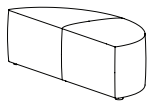

Half oval ottoman
Fully upholstered
Jump master stitched

Non-marring adjustable glides
Pivoting connectors

SCS Indoor Advantage™ Gold and LEVEL® 2 certified. See terms and conditions for additional environmental information.

Jump Mater Stitch Specification: Thread color must be specified. Reference Neighborhood/Stitching on Bernhardt.com for thread color options.

Seat Height	Arm Height	W	D	H	Fabric	Leather	Weight	Cubes/Qty
16½"	-	56"	21½"	16½"	3.5 yds.	60.0'	61 lbs.	20.0'/1
419 mm	-	1422 mm	546 mm	419 mm	3.2 m	5.6 sqm	27.7 kg	.57 cu.

COM	COL	1	2	3	4	5	6	7	8	9	10	11
1565	1635	1892	1947	1978	2040	2094	2118	2157	2211	2258	2312	2623

Tables for double-sided connecting modules



180° curved end module table with upholstered base. Non-marring adjustable glides. Pivoting connectors. Worksurface available in oak veneer, laminate and corian.
When specifying light finishes the natural characteristics of the wood will be visible and color will vary.
Upholstered base with saddle stitch or jump master stitch. Jump master stitch specification: Thread color must be specified.
Reference Neighborhood/Stitching on BernhardtDesign.com for color options.

Contact sales representative for approved Bernhardt Textiles for Neighborhood tables.
Connecting hardware provided for both left-hand and right-hand orientation.
When power is specified, (1) 15 amp receptacle, (1) 2 amp USB-A port, 10 watt and (1) 2 amp USB-C port, 20 watt are provided.
An upcharge of \$350 applies.

Worksurface Height	L	D	H	Fabric	Leather	Weight	Cubes/Qty
15½"	55½"	20½"	15½"	3.75 yds.	65.0'	89.25 lbs.	77.6'/1
394 mm	1410 mm	521 mm	394 mm	3.4 m	6.0 sqm	40.5 kg	2.2 cu.

neighborhood

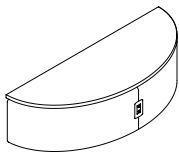

57X Oak Worksurface. Saddle Stitch Upholstered Base

COM	COL	1	2	3	4	5	6	7	8	9	10	11
2503	2578	2853	2912	2945	3012	3070	3095	3137	3195	3245	3303	3637

Specify veneer code C for oak worksurface. Specify finish code. Add \$350 when specifying power.

57X Laminate Worksurface. Saddle Stitch Upholstered Base

COM	COL	1	2	3	4	5	6	7	8	9	10	11
2034	2109	2384	2443	2476	2543	2601	2626	2668	2726	2776	2834	3168

Specify veneer code F for laminate designer white worksurface. Add \$350 when specifying power.

57X Corian Worksurface. Saddle Stitch Upholstered Base

COM	COL	1	2	3	4	5	6	7	8	9	10	11
3752	3827	4102	4161	4194	4261	4319	4344	4386	4444	4494	4552	4886

Specify veneer code 8 for corian glacier white worksurface. Add \$350 when specifying power.

neighborhood

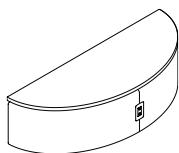

57J Oak Worksurface. Jump Master Stitch Upholstered Base

COM	COL	1	2	3	4	5	6	7	8	9	10	11
2620	2695	2970	3029	3062	3129	3187	3212	3254	3312	3362	3420	3754

Specify veneer code C for oak worksurface. Specify finish code. Add \$350 when specifying power.

57J Laminate Worksurface. Jump Master Stitch Upholstered Base

COM	COL	1	2	3	4	5	6	7	8	9	10	11
2152	2227	2502	2561	2594	2661	2719	2744	2786	2844	2894	2952	3286

Specify veneer code F for laminate designer white worksurface. Add \$350 when specifying power.

57J Corian Worksurface. Jump Master Stitch Upholstered Base

COM	COL	1	2	3	4	5	6	7	8	9	10	11
3870	3945	4220	4279	4312	4379	4437	4462	4504	4562	4612	4670	5004

Specify veneer code 8 for corian glacier white worksurface. Add \$350 when specifying power.

series	sku	veneer	power finish	power	finish
J		C oak F laminate - designer white 8 corian - glacier white	4 aluminum powder coat X none	X none Q power + usb (1) upcharge \$350	

Privacy Modules

neighborhood 6031T

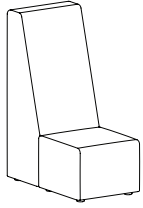

**Straight privacy connector
Fully upholstered
Saddle stitched**

Non-marring adjustable glides
Pivoting connectors
Leather is not applicable on back and back side panels of privacy modules

When using a combination of fabrics, specify the application by designating the appropriate letter, shown below, on the purchase order. Yardage shown must be used.

See terms and conditions for contrasting upholstery upcharges.

- A) One fabric or leather for seat
yardage: 2.25 yds. leather: 37.0 sq. ft.
- B) One fabric for back and back side panels
yardage: 4.0 yds.

SCS Indoor Advantage™ Gold and LEVEL® 2 certified. See terms and conditions for additional environmental information.

Seat Height	Arm Height	W	D	H	Fabric	Leather	Weight	Cubes/Qty
16½"	-	21½"	37"	48¾"	5.25 yds.	-	89 lbs.	30.0'/1
419 mm	-	546 mm	940 mm	1241 mm	4.8 m	-	40.1 kg	.85 cu.

COM	COL	1	2	3	4	5	6	7	8	9	10	11
2190	2295	2680	2762	2809	2902	2984	3019	3077	3159	3229	3310	3777

neighborhood 6031TJ

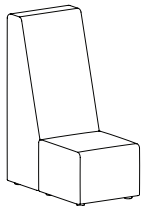

**Straight privacy connector
Fully upholstered
Jump master stitched**

Non-marring adjustable glides
Pivoting connectors
Leather is not applicable on back and back side panels of privacy modules

When using a combination of fabrics, specify the application by designating the appropriate letter, shown below, on the purchase order. Yardage shown must be used.

See terms and conditions for contrasting upholstery upcharges.

- A) One fabric or leather for seat
yardage: 2.25 yds leather: 37.0 sq. ft.
- B) One fabric for back. and back side panels
yardage: 4.0 yds.

SCS Indoor Advantage™ Gold and LEVEL® 2 certified. See terms and conditions for additional environmental information.

Jump Master Stitch Specification: Thread color must be specified. Reference Neighborhood/Stitching on BernhardtDesign.com for thread color options.

Seat Height	Arm Height	W	D	H	Fabric	Leather	Weight	Cubes/Qty
16½"	-	21½"	37"	48¾"	5.25 yds	-	89 lbs.	30.0'/1
419 mm	-	546 mm	940 mm	1241 mm	4.8 m	-	40.1 kg	.85 cu.

COM	COL	1	2	3	4	5	6	7	8	9	10	11
2345	2450	2835	2917	2964	3057	3139	3174	3232	3314	3384	3465	3932

Privacy Modules

neighborhood 6035T

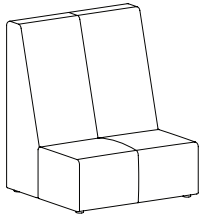

**Two-seat
Straight privacy connector
Fully upholstered
Saddle Stitched**

Non-marring adjustable glides
Pivoting connectors
Leather is not applicable on back and back side panels of privacy modules

When using a combination of fabrics, specify the application by designating the appropriate letter, shown below, on the purchase order. Yardage shown must be used.

See terms and conditions for contrasting upholstery upcharges.

- A) One fabric or leather for seat
yardage: 3.5 yds. leather: 57.0 sq. ft.
- B) One fabric for back and back side panels
yardage: 6.0 yds.

SCS Indoor Advantage™ Gold and LEVEL® 2 certified. See terms and conditions for additional environmental information.

Seat Height	Arm Height	W	D	H	Fabric	Leather	Weight	Cubes/Qty
16½"	-	41½"	37"	48⅞"	8.0 yds.	-	159 lbs.	55.13'/1
419 mm	-	1054 mm	940 mm	1241 mm	7.3 m	-	72.1 kg	1.56 cu.

COM	COL	1	2	3	4	5	6	7	8	9	10	11
3128	3288	3875	4000	4071	4213	4337	4391	4480	4604	4711	4835	5546

neighborhood 6035TJ

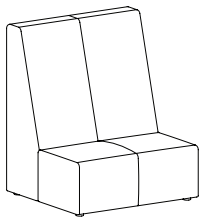

**Two-seat
Straight privacy connector
Fully upholstered
Jump master stitched**

Non-marring adjustable glides
Pivoting connectors
Leather is not applicable on back and back side panels of privacy modules

When using a combination of fabrics, specify the application by designating the appropriate letter, shown below, on the purchase order. Yardage shown must be used.

See terms and conditions for contrasting upholstery upcharges.

- A) One fabric or leather for seat
yardage: 3.5 yds. leather: 57.0 sq. ft.
- B) One fabric for back and back side panels
yardage: 6.0 yds.

SCS Indoor Advantage™ Gold and LEVEL® 2 certified. See terms and conditions for additional environmental information.

Jump Master Stitch Specification: Thread color must be specified. Reference Neighborhood/Stitching on BernhardtDesign.com for thread color options.

Seat Height	Arm Height	W	D	H	Fabric	Leather	Weight	Cubes/Qty
16½"	-	41½"	37"	48⅞"	8.0 yds.	-	159 lbs.	55.13'/1
419 mm	-	1054 mm	940 mm	1241 mm	7.3 m	-	72.1 kg	1.56 cu.

COM	COL	1	2	3	4	5	6	7	8	9	10	11
3362	3522	4109	4234	4305	4447	4571	4625	4714	4838	4945	5069	5780

Privacy Modules

neighborhood 6038T

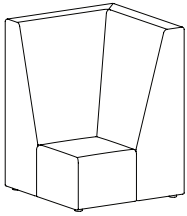

**90° Corner
Privacy connector
Fully upholstered
Saddle stitched**

Non-marring adjustable glides
Pivoting connectors
Leather is not applicable on back and back side panels of privacy modules

Diagonal Dimension: 51½"

When using a combination of fabrics, specify the application by designating the appropriate letter, shown below, on the purchase order. Yardage shown must be used.

See terms and conditions for contrasting upholstery upcharges.

- A) One fabric or leather for seat
yardage: 2.5 yds. leather: 41.0 sq. ft.
- B) One fabric for back and back side panels
yardage: 7.0 yds.

SCS Indoor Advantage™ Gold and LEVEL® 2 certified. See terms and conditions for additional environmental information.

Seat Height	Arm Height	W	D	H	Fabric	Leather	Weight	Cubes/Qty
16½"	-	51½"	51½"	48½"	7.8 yds.	-	139 lbs.	55.13/1
419 mm	-	1311 mm	1308 mm	1241 mm	7.8 m	-	60.0 kg	1.56 cu.

COM	COL	1	2	3	4	5	6	7	8	9	10	11
2660	2830	3454	3586	3662	3813	3945	4002	4096	4228	4342	4474	5229

neighborhood 6038TJ

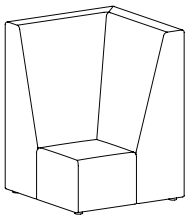

**90° Corner
Privacy connector
Fully upholstered
Jump master stitched**

Non-marring adjustable glides
Pivoting connectors
Leather is not applicable on back and back side panels of privacy modules

Diagonal Dimension: 51½"

When using a combination of fabrics, specify the application by designating the appropriate letter, shown below, on the purchase order. Yardage shown must be used.

See terms and conditions for contrasting upholstery upcharges.

- A) One fabric for leather for seat
yardage: 2.5 yds. leather: 41.0 sq. ft.
- B) One fabric for back and back side panels
yardage: 7.0 yds.

SCS Indoor Advantage™ Gold and LEVEL® 2 certified. See terms and conditions for additional environmental information.

Jump Master Stitch Specification: Thread color must be specified. Reference Neighborhood/Stitching on BernhardtDesign.com for thread color options.

Seat Height	Arm Height	W	D	H	Fabric	Leather	Weight	Cubes/Qty
16½"	-	51½"	51½"	48½"	8.5 yds.	-	139 lbs.	55.13/1
419 mm	-	1311 mm	1308 mm	1241 mm	7.8 m	-	60.0 kg	1.56 cu.

COM	COL	1	2	3	4	5	6	7	8	9	10	11
2892	3062	3686	3818	3894	4045	4177	4234	4328	4460	4574	4706	5461

Privacy Modules

neighborhood 6039T

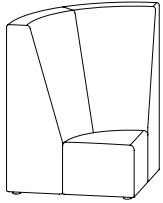

**90° Curved corner
Privacy connector
Fully upholstered
Saddle Stitched**

Non-marring adjustable glides
Pivoting connectors
Leather is not applicable on back and back side panels of privacy modules

When using a combination of fabrics, specify the application by designating the appropriate letter, shown below, on the purchase order. Yardage shown must be used.

See terms and conditions for contrasting upholstery upcharges.

- A) One fabric or leather for seat
yardage: 2.5 yds. leather: 41.0 sq. ft.
- B) One fabric for back and back side panels
yardage: 8.0 yds.

SCS Indoor Advantage™ Gold and LEVEL® 2 certified. See terms and conditions for additional environmental information..

Seat Height	Arm Height	W	D	H	Fabric	Leather	Weight	Cubes/Qty
16½"	-	51½"	36½"	48¾"	9.5 yds.	-	107 lbs.	55.13'/1
419 mm	-	1308 mm	927 mm	1241 mm	8.7 m	-	48.5 kg	1.56 cu.

COM	COL	1	2	3	4	5	6	7	8	9	10	11
2660	2850	3547	3695	3779	3948	4096	4159	4265	4413	4539	4687	5532

neighborhood 6039TJ

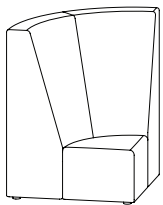

**90° Curved corner
Privacy connector
Fully upholstered
Jump master stitched**

Non-marring adjustable glides
Pivoting connectors
Leather is not applicable on back and back side panels of privacy modules

When using a combination of fabrics, specify the application by designating the appropriate letter, shown below, on the purchase order. Yardage shown must be used.

See terms and conditions for contrasting upholstery upcharges.

- A) One fabric or leather for seat
yardage: 2.5 yds. leather: 41.0 sq. ft
- B) One fabric for back and back side panels
yardage: 8.0 yds.

SCS Indoor Advantage™ Gold and LEVEL® 2 certified. See terms and conditions for additional environmental information.

Jump Master Stitch Specification: Thread color must be specified. Reference Neighborhood/Stitching on BernhardtDesign.com for thread color options.

Seat Height	Arm Height	W	D	H	Fabric	Leather	Weight	Cubes/Qty
16½"	-	51 1/2"	36½"	48¾"	9.5 yds.	-	107 lbs.	55.13'/1
419 mm	-	1308 mm	927 mm	1241 mm	8.7 m	-	48.5 kg	1.56 cu.

COM	COL	1	2	3	4	5	6	7	8	9	10	11
2892	3082	3779	3927	4011	4180	4328	4391	4497	4645	4771	4919	5764

Privacy Modules

neighborhood 6040T

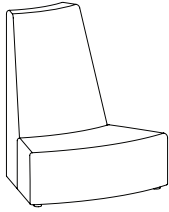

**45° Inverted curved
Privacy connector
Fully upholstered
Saddle stitched**

Non-marring adjustable glides
Pivoting connectors
Leather is not applicable on back and back side panels of privacy modules

When using a combination of fabrics, specify the application by designating the appropriate letter, shown below, on the purchase order. Yardage shown must be used.

See terms and conditions for contrasting upholstery upcharges.

- A) One fabric or leather for seat
yardage: 3.5 yds. leather: 57.0 sq. ft.
- B) One fabric for back and back side panels
yardage: 4.0 yds.

SCS Indoor Advantage™ Gold and LEVEL® 2 certified. See terms and conditions for additional environmental information.

Seat Height	Arm Height	W	D	H	Fabric	Leather	Weight	Cubes/Qty
16½"	-	45⅞"	38¼"	48⅞"	6.5 yds.	-	99 lbs.	63.0'/1
419 mm	-	1165 mm	972 mm	1241 mm	6.0 m	-	44.9 kg	1.78 cu.

COM	COL	1	2	3	4	5	6	7	8	9	10	11
2503	2633	3110	3211	3269	3385	3486	3529	3601	3702	3789	3890	4468

neighborhood 6040TJ

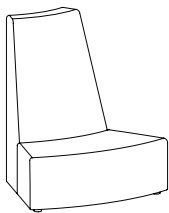

**45° Inverted curved
Privacy connector
Fully upholstered
Jump master stitched**

Non-marring adjustable glides
Pivoting connectors
Leather is not applicable on back and back side panels of privacy modules

When using a combination of fabrics, specify the application by designating the appropriate letter, shown below, on the purchase order. Yardage shown must be used.

See terms and conditions for contrasting upholstery upcharges.

- A) One fabric or leather for seat
yardage: 3.5 yds. leather: 57.0 sq. ft.
- B) One fabric for back and back side panels
yardage: 4.0 yds.

SCS Indoor Advantage™ Gold and LEVEL® 2 certified. See terms and conditions for additional environmental information.

Jump Master Stitch Specification: Thread color must be specified. Reference Neighborhood/Stitching on BernhardtDesign.com for thread color options.

Seat Height	Arm Height	W	D	H	Fabric	Leather	Weight	Cubes/Qty
16½"	-	45⅞"	38¼"	48⅞"	6.5 yds.	-	99 lbs.	63.0'/1
419 mm	-	1165 mm	972 mm	1241 mm	6.0 m	-	44.9 kg	1.78 cu.

COM	COL	1	2	3	4	5	6	7	8	9	10	11
2660	2790	3267	3368	3426	3542	3643	3686	3758	3859	3946	4047	4625

Privacy Modules

neighborhood 6041T

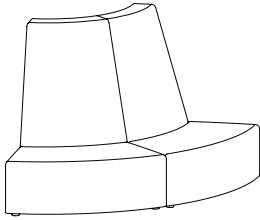

**90° inverted curved
Privacy connector
Fully upholstered
Saddle stitched**

Non-marring adjustable glides
Pivoting connectors
Leather is not applicable on back and back side panels of privacy modules

When using a combination of fabrics, specify the application by designating the appropriate letter, shown below, on the purchase order. Yardage shown must be used.

See terms and conditions for contrasting upholstery upcharges.

- A) One fabric or leather for seat
yardage: 6.0 yds. leather: 98.0 sq. ft.
- B) One fabric for back and back side panels
yardage: 6.5 yds.

SCS Indoor Advantage™ Gold and LEVEL® 2 certified. See terms and conditions for additional environmental information

Seat Height	Arm Height	W	D	H	Fabric	Leather	Weight	Cubes/Qty
16½"	-	85½"	43½"	48⅞"	11.0 yds.	-	184 lbs.	135.0/1
419 mm	-	2172 mm	1105 mm	1241 mm	10.1 m	-	83.5kg	3.83 cu.

COM	COL	1	2	3	4	5	6	7	8	9	10	11
3752	3972	4779	4950	5048	5244	5415	5488	5610	5781	5928	6099	7077

neighborhood 6041TJ

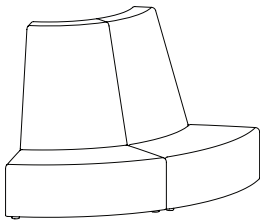

**90° inverted curved
Privacy connector
Fully upholstered
Jump master stitched**

Non-marring adjustable glides
Pivoting connectors
Leather is not applicable on back and back side panels of privacy modules

When using a combination of fabrics, specify the application by designating the appropriate letter, shown below, on the purchase order. Yardage shown must be used.

See terms and conditions for contrasting upholstery upcharges.

- A) One fabric or leather for seat
yardage: 6.0 yds. leather: 98.0 sq. ft.
- B) One fabric for back and back side panels
yardage: 6.5 yds.

SCS Indoor Advantage™ Gold and LEVEL® 2 certified. See terms and conditions for additional environmental information.

Jump Master Stitch Specification: Thread color must be specified. Reference Neighborhood/Stitching on BernhardtDesign.com for thread color options.

Seat Height	Arm Height	W	D	H	Fabric	Leather	Weight	Cubes/Qty
16½"	-	85½"	43½"	48⅞"	11.0 yds.	-	184 lbs.	135.0/1
419 mm	-	2172 mm	1105 mm	1241 mm	10.1 m	-	83.5kg	3.83 cu.

COM	COL	1	2	3	4	5	6	7	8	9	10	11
4064	4284	5091	5262	5360	5556	5727	5800	5922	6093	6240	6411	7389

Privacy Modules

neighborhood 6048T

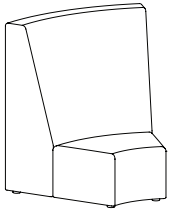

45° Curved privacy connector
Fully upholstered
Saddle stitched

Non-marring adjustable glides
Pivoting connectors
Leather is not applicable on back and back side panels of privacy modules

When using a combination of fabrics or leathers, specify the application by designating the appropriate letter, shown below, on the purchase order. Yardage shown must be used.

See terms and conditions for contrasting upholstery upcharges.

- A) One fabric of leather for seat
yardage: 3.0 yds. leather: 49.0 sq. ft.
- B) One fabric for back and back side panels
yardage: 6.0 yds.

SCS Indoor Advantage™ Gold and LEVEL® 2 certified. See terms and conditions for additional environmental information..

Seat Height	Arm Height	W	D	H	Fabric	Leather	Weight	Cubes/Qty
16½"	-	46"	38½"	48¾"	8.0 yds.	-	126 lbs.	54.0'/1
419 mm	-	1168 mm	978 mm	1241 mm	7.3 m	-	57.2 kg	1.53 cu.

COM	COL	1	2	3	4	5	6	7	8	9	10	11
2660	2820	3407	3532	3603	3745	3869	3923	4012	4136	4243	4367	5078

neighborhood 6048TJ

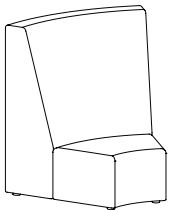

45° Curved privacy connector
Fully upholstered
Jump master stitched

Non-marring adjustable glides
Pivoting connectors
Leather is not applicable on back and back side panels of privacy modules

When using a combination of fabrics or leathers, specify the application by designating the appropriate letter, shown below, on the purchase order. Yardage shown must be used.

See terms and conditions for contrasting upholstery upcharges.

- A) One fabric or leather for seat
yardage: 3.0 yds. leather: 49.0 sq. ft.
- B) One fabric for back and back side panels
yardage: 6.0 yds.

SCS Indoor Advantage™ Gold and LEVEL® 2 certified. See terms and conditions for additional environmental information.

Jump Master Stitch Specification: Thread color must be specified. Reference Neighborhood/Stitching on BernhardtDesign.com for thread color options.

Seat Height	Arm Height	W	D	H	Fabric	Leather	Weight	Cubes/Qty
16½"	-	46"	38½"	48¾"	8.0 yds.	-	126 lbs.	54.0'/1
419 mm	-	1168 mm	978 mm	1241 mm	7.3 m	-	57.2 kg	1.53 cu.

COM	COL	1	2	3	4	5	6	7	8	9	10	11
2815	2975	3562	3687	3758	3900	4024	4078	4167	4291	4398	4522	5233

Privacy Modules

neighborhood 6049T

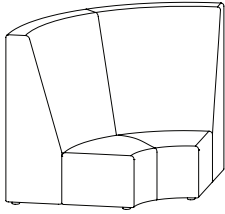

90° Curved privacy connector
Fully upholstered
Saddle stitched

Non-marring adjustable glides
Pivoting connectors
Leather is not applicable on back and back side panels of privacy modules

When using a combination of fabrics, specify the application by designating the appropriate letter, shown below, on the purchase order. Yardage shown must be used.

See terms and conditions for contrasting upholstery upcharges.

- A) One fabric or leather for seat
yardage: 4.0 yds. leather: 65.0 sq. ft.
- B) One fabric for back and back side panels
yardage: 8.0 yds.

SCS Indoor Advantage™ Gold and LEVEL® 2 certified. See terms and conditions for additional environmental information.

Seat Height	Arm Height	W	D	H	Fabric	Leather	Weight	Cubes/Qty
16½"	-	73½"	41½"	48⅞"	10.5 yds.	-	191 lbs.	162.0/1
419 mm	-	1867 mm	1045 mm	1241 mm	9.6 m	-	86.6 kg	4.59 cu.

COM	COL	1	2	3	4	5	6	7	8	9	10	11
3752	3962	4732	4896	4989	5176	5339	5409	5526	5689	5829	5992	6926

neighborhood 6049TJ

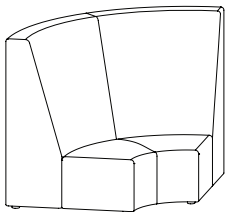

90° Curved privacy connector
Fully upholstered
Jump master stitched

Non-marring adjustable glides
Pivoting connectors
Leather is not applicable on back and back side panels of privacy modules

When using a combination of fabrics, specify the application by designating the appropriate letter, shown below, on the purchase order. Yardage shown must be used.

See terms and conditions for contrasting upholstery upcharges.

- A) One fabric or leather for seat
yardage: 4.0 yds. leather: 65.0 sq. ft.
- B) One fabric for back and back side panels
yardage: 8.0 yds.

SCS Indoor Advantage™ Gold and LEVEL® 2 certified. See terms and conditions for additional environmental information.

Jump Master Stitch Specification: Thread color must be specified. Reference Neighborhood/Stitching on BernhardtDesign.com for thread color options.

Seat Height	Arm Height	W	D	H	Fabric	Leather	Weight	Cubes/Qty
16½"	-	73½"	41½"	48⅞"	10.5 yds.	-	191 lbs.	162.0/1
419 mm	-	1867 mm	1045 mm	1241 mm	9.6 m	-	86.6 kg	4.59 cu.

COM	COL	1	2	3	4	5	6	7	8	9	10	11
4064	4274	5044	5208	5301	5488	5651	5721	5838	6001	6141	6304	7238



pasadena lounge modular seating collection

Pasadena Seating System Specification Guide

Standard Features



Pasadena is a modular seating system comprised of 64 unique modules which can be used as freestanding or interchangeably to create an unlimited number of configurations. Options include freestanding benches, two and three-seat modules, corner modules and seating and bench modules with end tables. End table tops are available in oak and walnut as well as black or white phenolic materials. All table options are offered with and without power. Base assemblies are available in all powder coat finishes or with polished aluminum.

Pasadena is fully upholstered. Each unit comes standard with felt glides installed and ships with non-marring nylon glides that can be installed as needed. When ordering configurations, please provide the total COM yardage from the same dye lot in a continuous roll(s). All COM/COL fabrics must be preapproved by Bernhardt Design prior to application.

All configurations are connected by a ganging bracket. Ganging brackets are sold separately and field installed. See the Pasadena accessories page for ordering information.

Pasadena is SCS Indoor Advantage™ Gold certified. See terms and conditions for additional finish and environmental information. Please visit bernhardtdesign.com for a complete library of 2D, 3D and Revit models. You may also contact your local sales representative or the Bernhardt Design Corporate Office for specification assistance.

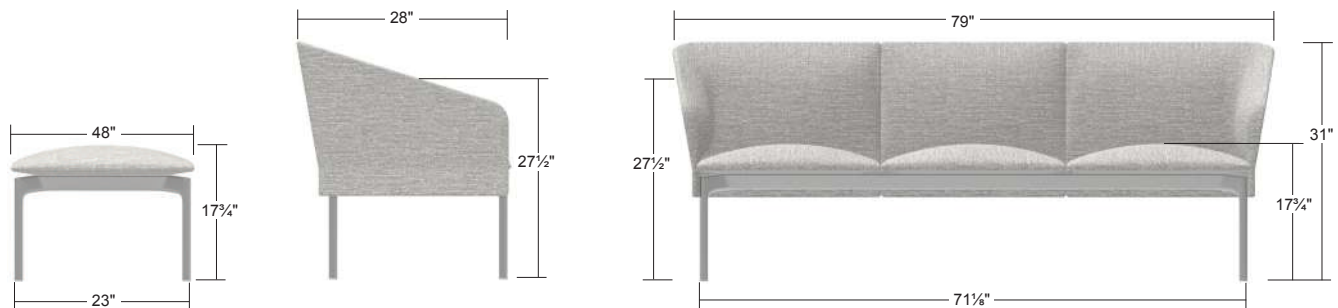

Table Options



Veneer Selection

A sku identifies each wood veneer option as well as standard finishes. Base and top finishes are specified separately.

When specifying light finishes the natural characteristics of the wood will be visible and color will vary. See terms and conditions for additional finish information.

C Oak
Rift Cut

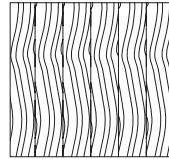

Standard Finish
871 870 839
837 860 861
865 836 866
872 805 845

9 Walnut
Quarter Cut

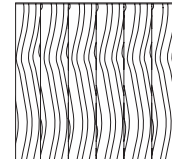

Standard Finish
872 861
870 823
860 866
839

OAK Select Finishes

M73 M72 M75
M74 M76 M77
M71

Solid Surface Selections

PHL Phenolic

STW Designer White, Wilsonart 15512 SOLICOR, D354-60 Matte Finish

STB Black Velvet, Wilsonart 15505 Compact Traceless

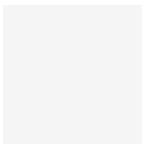

STW

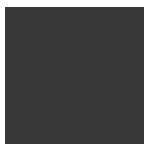

STB

Edge Profiles

Wood Veneer Edge



Solid Surface Edge



Surface Mount Power Modules

Pasadena offers a proprietary surface mount power solution which is installed flush to the worksurface and provides (2) 15 amp receptacles and (1) 2 amp USB-A port and (1) 2 amp USB-C port. The unit has a 10' infeed with a grounded plug. Power module finish is determined by table finish selection. The power module location is determined by table location as shown below.

Power Module

Black or White Finish

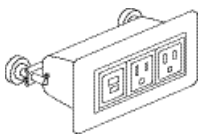

(2) 120 v 60 Hz. 15 amp receptacles
(1) 2 amp USB-A port, 10 watt
(1) 2 amp USB-C port, 20 watt
6 1/2" w x 3" d x 2 3/4" h

In Line Power Location

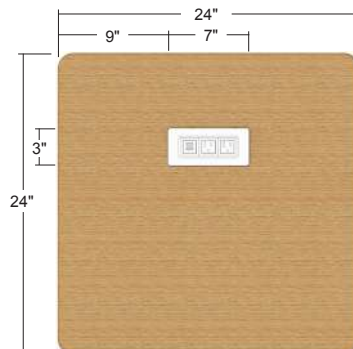

Corner Table Power Location

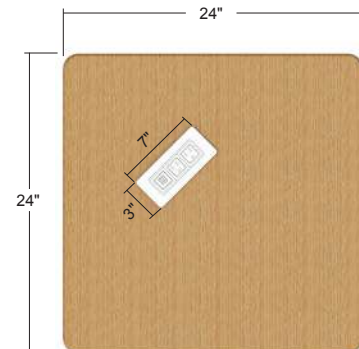

Connecting Modules



Pasadena modules connect by attaching a ganging bracket to the underside of the module. Order one ganging bracket per point of connection. Ganging brackets are sold separately and will ship with the product. See Pasadena accessories page to order brackets.

To connect the modules together, attach one end of the bracket to the underside of one module using the supplied hardware. The ganging brackets are formed to nest around the extruded base rails. Push modules together into desired location then attach the other end of the bracket in the same manner.



Ganging Bracket
14½" w x 9" d x 9½" h



End to End Connection

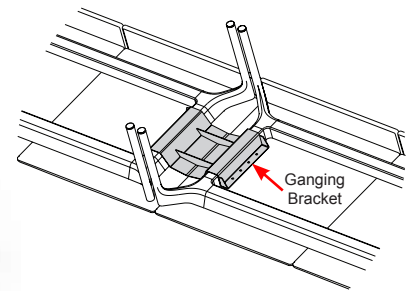

Under side view of the ganging bracket placement



Corner to End Connection

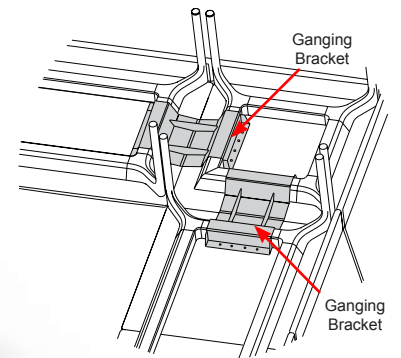

Pasadena Seating System Sample Configurations

1

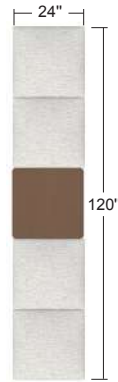

SKU	Description
6SSX	Two-Seat Bench
6TSS	Two-Seat Bench with end table, Right Side Facing

2

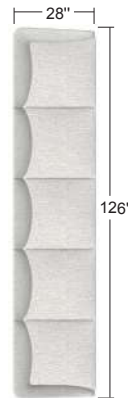

6ALL	Three-Seat Module, Left Side Facing
6LAX	Two-Seat Module, Right Side Facing

3

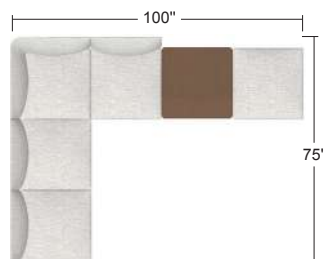

6LLX	Two-Seat Armless Module
6CXX	Corner Seat
6LTS	Two-Seat Armless Open End Module with Center Table, Left Side Facing

Pasadena Seating System Sample Configurations

4

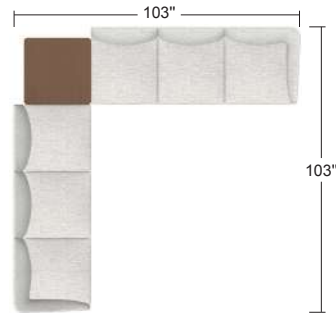

SKU Description

- 6ALL** Three-Seat Module, Left Side Facing
- 6KXX** Corner Table
- 6LLA** Three-Seat Module, Right Side Facing

5

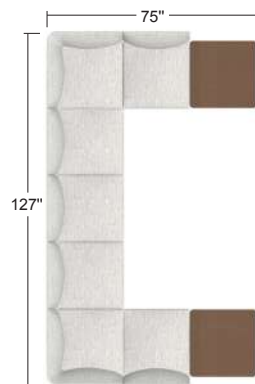

- 6TLX** Armless Module with End Table, Right Side Facing
- 6CXX** Corner Seat
- 6LLL** Three-Seat Armless Module
- 6CXX** Corner Seat
- 6LTX** Armless Module with End Table, Left Side Facing

6

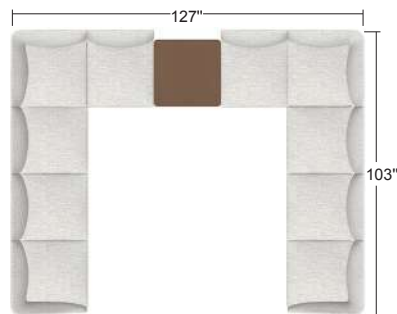

- 6ALL** Three-Seat Module, Left Side Facing
- 6CXX** Corner Seat
- 6LTL** Two-Seat Armless Module with Center Table
- 6CXX** Corner Seat
- 6LLA** Three-Seat Module, Right Side Facing

Pasadena 6SSX

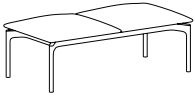

Two-seat bench
Polished aluminum or powder coat base
Upholstered

Ganging brackets are sold separately and will ship with the product. See Pasadena accessories page to order brackets.

SCS Indoor Advantage™ Gold and LEVEL® 2 certified. See terms and conditions for additional environmental information.

Seat Height	Arm Height	W	D	H	Fabric	Leather	Weight	Cubes/Qty
17¾"	-	48"	24"	17¾"	4.0 yds	65.0'	84 lbs.	32.89'/1
451 mm	-	1219 mm	610 mm	451 mm	3.7 m	6.0 sqm	38.1 kg	.93 cu.

COM	COL	1	2	3	4	5	6	7	8	9	10	11
2109	2189	2483	2545	2581	2652	2714	2741	2785	2847	2901	2963	3318

Pasadena 6STX

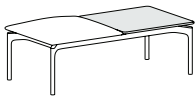

One seat bench with end table
Left side facing
Polished aluminum or powder coat base
Upholstered

End table available in phenolic and all oak and walnut finishes, except for walnut LV8. When specifying light finish the natural characteristics of the wood will be visible and color will vary.

Ganging brackets are sold separately and will ship with the product. See Pasadena accessories page to order brackets.

SCS Indoor Advantage™ Gold and LEVEL® 2 certified. See terms and conditions for additional environmental information.

*Weight shown represents shipping weight for wood top. Shipping weight for phenolic top is 97 lbs./44.0 kg.

Seat Height	Arm Height	W	D	H	Fabric	Leather	Weight	Cubes/Qty
17¾"	-	48"	24"	17¾"	2.25 yds	37.0'	*89 lbs.	32.89'/1
451 mm	-	1220 mm	610 mm	451 mm	2.1 m	3.4 sqm	40.4 kg	.93 cu.

COM	COL	1	2	3	4	5	6	7	8	9	10	11
2542	2587	2752	2787	2807	2847	2882	2897	2922	2957	2987	3022	3222

sku	top material	base finish
_____	C oak	PA polished aluminum standard, OR
_____	9 walnut	
_____	phenolic upcharge \$650	specify powder coat, upcharge \$250
_____	W phenolic - white	WH satin white
_____	B phenolic - black	EC ecru
_____	X none	LA latte
_____		AL aluminum
_____		GR graphite
_____		BZ bronze
_____		SG sage
_____		IG iron grey
_____		RD black red
_____		BK matte black

Pasadena 6SBX

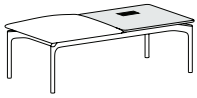

Power - black module
One seat bench with end table
Left side facing
Polished aluminum or powder coat base
Upholstered

End table available in phenolic and all oak and walnut finishes, except for walnut LV8. When specifying light finish the natural characteristics of the wood will be visible and color will vary.

Ganging brackets are sold separately and will ship with the product. See Pasadena accessories page to order brackets.

Power: Surface mount power provides (2) 15 amp receptacles and (2) 2 amp USB-C ports, 20 watt.

SCS Indoor Advantage™ Gold and LEVEL® 2 certified. See terms and conditions for additional environmental information.

*Weight shown represents shipping weight for wood top. Shipping weight for phenolic top is 98 lbs./44.4 kg.

Seat Height	Arm Height	W	D	H	Fabric	Leather	Weight	Cubes/Qty
17¾"	-	48"	24"	17¾"	2.25 yds	37.0'	*90 lbs.	32.89'/1
451 mm	-	1221 mm	610 mm	451 mm	2.1 m	3.4 sqm	41.0 kg	.93 cu.

COM	COL	1	2	3	4	5	6	7	8	9	10	11
3010	3055	3220	3255	3275	3315	3350	3365	3390	3425	3455	3490	3690

Pasadena 6SWX

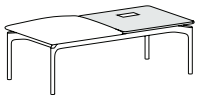

Power - white module
One seat bench with end table
Left side facing
Polished aluminum or powder coat base
Upholstered

End table available in phenolic and all oak and walnut finishes, except for walnut LV8. When specifying light finish the natural characteristics of the wood will be visible and color will vary.

Ganging brackets are sold separately and will ship with the product. See Pasadena accessories page to order brackets.

Power: Surface mount power provides (2) 15 amp receptacles and (2) 2 amp USB-C ports, 20 watt.

SCS Indoor Advantage™ Gold and LEVEL® 2 certified. See terms and conditions for additional environmental information.

*Weight shown represents shipping weight for wood top. Shipping weight for phenolic top is 98 lbs./44.4 kg.

Seat Height	Arm Height	W	D	H	Fabric	Leather	Weight	Cubes/Qty
17¾"	-	48"	24"	17¾"	2.25 yds	37.0'	*90 lbs.	32.89'/1
451 mm	-	1225 mm	610 mm	451 mm	2.1 m	3.4 sqm	41.0 kg	.93 cu.

COM	COL	1	2	3	4	5	6	7	8	9	10	11
3010	3055	3220	3255	3275	3315	3350	3365	3390	3425	3455	3490	3690

sku	top material	base finish
	C oak	PA polished aluminum standard, OR
	9 walnut	
	phenolic upcharge \$650	specify powder coat, upcharge \$250
	W phenolic - white	WH satin white
	B phenolic - black	EC ecru
		LA latte
	X none	AL aluminum
		GR graphite
		BZ bronze
		SG sage
		IG iron grey
		RD black red
		BK matte black

Pasadena 6TSX

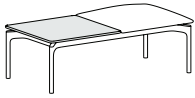

One seat bench with end table
Right side facing
Polished aluminum or powder coat base
Upholstered

End table available in phenolic and all oak and walnut finishes, except for walnut LV8. When specifying light finish the natural characteristics of the wood will be visible and color will vary.

Ganging brackets are sold separately and will ship with the product. See Pasadena accessories page to order brackets.

SCS Indoor Advantage™ Gold and LEVEL® 2 certified. See terms and conditions for additional environmental information.

*Weight shown represents shipping weight for wood top. Shipping weight for phenolic top is 97 lbs./44.0 kg.

Seat Height	Arm Height	W	D	H	Fabric	Leather	Weight	Cubes/Qty
17¾"	-	48"	24"	17¾"	2.25 yds	37.0'	89 lbs.	32.89/1
451 mm	-	1223 mm	610 mm	451 mm	2.1 m	3.4 sqm	40.4 kg	.93 cu.

COM	COL	1	2	3	4	5	6	7	8	9	10	11
2542	2587	2752	2787	2807	2847	2882	2897	2922	2957	2987	3022	3222

Pasadena 6BSX

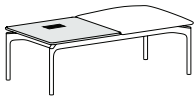

Power - black module
One seat bench with end table
Right side facing
Polished aluminum or powder coat base
Upholstered

End table available in phenolic and all oak and walnut finishes, except for walnut LV8. When specifying light finish the natural characteristics of the wood will be visible and color will vary.

Ganging brackets are sold separately and will ship with the product. See Pasadena accessories page to order brackets.

Power: Surface mount power provides (2) 15 amp receptacles and (2) 2 amp USB-C ports, 20 watt.

SCS Indoor Advantage™ Gold and LEVEL® 2 certified. See terms and conditions for additional environmental information.

*Weight shown represents shipping weight for wood top. Shipping weight for phenolic top is 98 lbs./44.4 kg.

Seat Height	Arm Height	W	D	H	Fabric	Leather	Weight	Cubes/Qty
17¾"	-	48"	24"	17¾"	2.25 yds	37.0'	*90 lbs.	32.89/1
451 mm	-	1224 mm	610 mm	451 mm	2.1 m	3.4 sqm	41.0 kg	.93 cu.

COM	COL	1	2	3	4	5	6	7	8	9	10	11
3010	3055	3220	3255	3275	3315	3350	3365	3390	3425	3455	3490	3690

sku	top material	base finish
	C oak	PA polished aluminum standard, OR
	9 walnut	
	phenolic upcharge \$650	specify powder coat, upcharge \$250
	W phenolic - white	WH satin white
	B phenolic - black	EC ecru
		LA latte
	X none	AL aluminum
		GR graphite
		BZ bronze
		SG sage
		IG iron grey
		RD black red
		BK matte black

Pasadena 6WSX

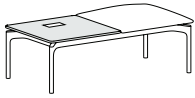

Power - white module
One seat bench with end table
Right side facing
Polished aluminum or powder coat base
Upholstered

End table available in phenolic and all oak and walnut finishes, except for walnut LV8. When specifying light finish the natural characteristics of the wood will be visible and color will vary.

Ganging brackets are sold separately and will ship with the product. See Pasadena accessories page to order brackets.

Power: Surface mount power provides (2) 15 amp receptacles and (2) 2 amp USB-C ports, 20 watt.

SCS Indoor Advantage™ Gold and LEVEL® 2 certified. See terms and conditions for additional environmental information.

*Weight shown represents shipping weight for wood top. Shipping weight for phenolic top is 98 lbs./44.4 kg.

Seat Height	Arm Height	W	D	H	Fabric	Leather	Weight	Cubes/Qty
17¾"	-	48"	24"	17¾"	2.25 yds	37.0'	*90 lbs.	32.89'/1
451 mm	-	1225 mm	610 mm	451 mm	2.1 m	3.4 sqm	41.0 kg	.93 cu.

COM	COL	1	2	3	4	5	6	7	8	9	10	11
3010	3055	3220	3255	3275	3315	3350	3365	3390	3425	3455	3490	3690
3010	3055	3220	3255	3275	3315	3350	3365	3390	3425	3455	3490	3690

Pasadena 6SSS

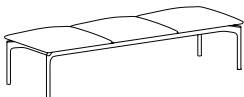

Three-seat bench
Polished aluminum or powder coat base
Upholstered

Ganging brackets are sold separately and will ship with the product. See Pasadena accessories page to order brackets.

SCS Indoor Advantage™ Gold and LEVEL® 2 certified. See terms and conditions for additional environmental information.

Seat Height	Arm Height	W	D	H	Fabric	Leather	Weight	Cubes/Qty
17¾"	-	72"	24"	17¾"	5.75 yds	94.0'	113 lbs.	44.71'/1
451 mm	-	1829 mm	610 mm	451 mm	5.3 m	8.7 sqm	51.3 kg	1.3 cu.

COM	COL	1	2	3	4	5	6	7	8	9	10	11
2597	2712	3134	3224	3275	3377	3466	3505	3569	3658	3735	3824	4335

sku	top material	base finish
	C oak	PA polished aluminum standard, OR
	9 walnut	
	phenolic upcharge \$650	specify powder coat, upcharge \$250
	W phenolic - white	WH satin white
	B phenolic - black	EC ecru
	X none	LA latte
		AL aluminum
		GR graphite
		BZ bronze
		SG sage
		IG iron grey
		RD black red
		BK matte black

Pasadena 6SST

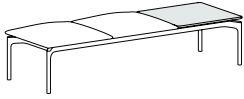

Two-seat bench with end table
Left side facing
Polished aluminum or powder coat base
Upholstered

End table available in phenolic and all oak and walnut finishes, except for walnut LV8. When specifying light finish the natural characteristics of the wood will be visible and color will vary.

Ganging brackets are sold separately and will ship with the product. See Pasadena accessories page to order brackets.

SCS Indoor Advantage™ Gold and LEVEL® 2 certified. See terms and conditions for additional environmental information.

*Weight shown represents shipping weight for wood top. Shipping weight for phenolic top is 126 lbs./57.2 cu.

Seat Height	Arm Height	W	D	H	Fabric	Leather	Weight	Cubes/Qty
17¾"	-	72"	24"	17¾"	4.0 yds	65.0'	*118 lbs.	44.71'/1
451 mm	-	1830 mm	610 mm	451 mm	3.7 m	6.0 sqm	54.9 kg	1.3 cu.

COM	COL	1	2	3	4	5	6	7	8	9	10	11
2975	3055	3349	3411	3447	3518	3580	3607	3651	3713	3767	3829	4184

Pasadena 6SSB

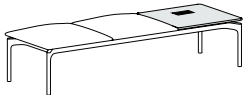

Power - black module
Two-seat bench with end table
Left side facing
Polished aluminum or powder coat base
Upholstered

End table available in phenolic and all oak and walnut finishes, except for walnut LV8. When specifying light finish the natural characteristics of the wood will be visible and color will vary.

Ganging brackets are sold separately and will ship with the product. See Pasadena accessories page to order brackets.

Power: Surface mount power provides (2) 15 amp receptacles and (2) 2 amp USB-C ports, 20 watt.

SCS Indoor Advantage™ Gold and LEVEL® 2 certified. See terms and conditions for additional environmental information.

*Weight shown represents shipping weight for wood top. Shipping weight for phenolic top is 127 lbs./58.0 cu.

Seat Height	Arm Height	W	D	H	Fabric	Leather	Weight	Cubes/Qty
17¾"	-	72"	24"	17¾"	4.0 yds	65.0'	119 lbs.	44.71'/1
451 mm	-	1831 mm	610 mm	451 mm	3.7 m	6.0 sqm	54.1 kg	1.3 cu.

COM	COL	1	2	3	4	5	6	7	8	9	10	11
3443	3523	3817	3879	3915	3986	4048	4075	4119	4181	4235	4297	4652

sku	top material	base finish
	C oak	PA polished aluminum standard, OR
	9 walnut	
	phenolic upcharge \$650	specify powder coat, upcharge \$250
	W phenolic - white	WH satin white
	B phenolic - black	EC ecru
		LA latte
	X none	AL aluminum
		GR graphite
		BZ bronze
		SG sage
		IG iron grey
		RD black red
		BK matte black

Pasadena 6SSW

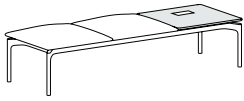

Power - white module
Two-seat bench with end table
Left side facing
Polished aluminum or powder coat base
Upholstered

End table available in phenolic and all oak and walnut finishes, except for walnut LV8. When specifying light finish the natural characteristics of the wood will be visible and color will vary.

Ganging brackets are sold separately and will ship with the product. See Pasadena accessories page to order brackets.

Power: Surface mount power provides (2) 15 amp receptacles and (2) 2 amp USB-C ports, 20 watt.

SCS Indoor Advantage™ Gold and LEVEL® 2 certified. See terms and conditions for additional environmental information.

*Weight shown represents shipping weight for wood top. Shipping weight for phenolic top is 127 lbs./58.0 cu.

Seat Height	Arm Height	W	D	H	Fabric	Leather	Weight	Cubes/Qty
17¾"	-	72"	24"	17¾"	4.0 yds	65.0'	*119 lbs.	44.71'/1
451 mm	-	1832 mm	610 mm	451 mm	3.7 m	6.0 sqm	54.1 kg	1.3 cu.

COM	COL	1	2	3	4	5	6	7	8	9	10	11
3443	3523	3817	3879	3915	3986	4048	4075	4119	4181	4235	4297	4652

Pasadena 6TSS

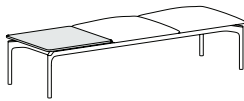

Two-seat bench with end table
Right side facing
Polished aluminum or powder coat base
Upholstered

End table available in phenolic and all oak and walnut finishes, except for walnut LV8. When specifying light finish the natural characteristics of the wood will be visible and color will vary.

Ganging brackets are sold separately and will ship with the product. See Pasadena accessories page to order brackets.

SCS Indoor Advantage™ Gold and LEVEL® 2 certified. See terms and conditions for additional environmental information.

*Weight shown represents shipping weight for wood top. Shipping weight for phenolic top is 126 lbs./57.2 cu.

Seat Height	Arm Height	W	D	H	Fabric	Leather	Weight	Cubes/Qty
17¾"	-	72"	24"	17¾"	4.0 yds	65.0'	*118 lbs.	44.71'/1
451 mm	-	1833 mm	610 mm	451 mm	3.7 m	6.0 sqm	54.9 kg	1.3 cu.

COM	COL	1	2	3	4	5	6	7	8	9	10	11
2975	3055	3349	3411	3447	3518	3580	3607	3651	3713	3767	3829	4184

sku	top material	base finish
	C oak	PA polished aluminum standard, OR
	9 walnut	
	phenolic upcharge \$650	specify powder coat, upcharge \$250
	W phenolic - white	WH satin white
	B phenolic - black	EC ecru
		LA latte
	X none	AL aluminum
		GR graphite
		BZ bronze
		SG sage
		IG iron grey
		RD black red
		BK matte black

Pasadena 6BSS

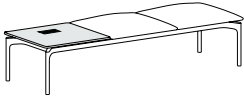

Power - black module
Two-seat bench with end table
Right side facing
Polished aluminum or powder coat base
Upholstered

End table available in phenolic and all oak and walnut finishes, except for walnut LV8. When specifying light finish the natural characteristics of the wood will be visible and color will vary.

Ganging brackets are sold separately and will ship with the product. See Pasadena accessories page to order brackets.

Power: Surface mount power provides (2) 15 amp receptacles and (2) 2 amp USB-C ports, 20 watt.

SCS Indoor Advantage™ Gold and LEVEL® 2 certified. See terms and conditions for additional environmental information.

*Weight shown represents shipping weight for wood top. Shipping weight for phenolic top is 127 lbs./58.0 cu.

Seat Height	Arm Height	W	D	H	Fabric	Leather	Weight	Cubes/Qty
17¾"	-	72"	24"	17¾"	4.0 yds	65.0'	*119 lbs.	44.71'/1
451 mm	-	1834 mm	610 mm	451 mm	3.7 m	6.0 sqm	54.1 kg	1.3 cu.

COM	COL	1	2	3	4	5	6	7	8	9	10	11
3443	3523	3817	3879	3915	3986	4048	4075	4119	4181	4235	4297	4652

Pasadena 6WSS

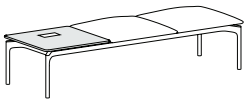

Power - white module
Two-seat bench with end table
Right side facing
Polished aluminum or powder coat base
Upholstered

End table available in phenolic and all oak and walnut finishes, except for walnut LV8. When specifying light finish the natural characteristics of the wood will be visible and color will vary.

Ganging brackets are sold separately and will ship with the product. See Pasadena accessories page to order brackets.

Power: Surface mount power provides (2) 15 amp receptacles and (2) 2 amp USB-C ports, 20 watt.

SCS Indoor Advantage™ Gold and LEVEL® 2 certified. See terms and conditions for additional environmental information.

*Weight shown represents shipping weight for wood top. Shipping weight for phenolic top is 127 lbs./58.0 cu.

Seat Height	Arm Height	W	D	H	Fabric	Leather	Weight	Cubes/Qty
17¾"	-	72"	24"	17¾"	4.0 yds	65.0'	*119 lbs.	44.71'/1
451 mm	-	1835 mm	610 mm	451 mm	3.7 m	6.0 sqm	54.1 kg	1.3 cu.

COM	COL	1	2	3	4	5	6	7	8	9	10	11
3443	3523	3817	3879	3915	3986	4048	4075	4119	4181	4235	4297	4652

sku	top material	base finish
	C oak	PA polished aluminum standard, OR
	9 walnut	
	phenolic upcharge \$650	specify powder coat, upcharge \$250
	W phenolic - white	WH satin white
	B phenolic - black	EC ecru
		LA latte
	X none	AL aluminum
		GR graphite
		BZ bronze
		SG sage
		IG iron grey
		RD black red
		BK matte black

Pasadena 6STS

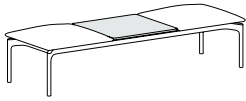

Two-seat bench with center table
Polished aluminum or powder coat base
Upholstered

End table available in phenolic and all oak and walnut finishes, except for walnut LV8. When specifying light finish the natural characteristics of the wood will be visible and color will vary.

Ganging brackets are sold separately and will ship with the product. See Pasadena accessories page to order brackets.

SCS Indoor Advantage™ Gold and LEVEL® 2 certified. See terms and conditions for additional environmental information.

*Weight shown represents shipping weight for wood top. Shipping weight for phenolic top is 126 lbs./57.2 cu.

Seat Height	Arm Height	W	D	H	Fabric	Leather	Weight	Cubes/Qty
17¾"	-	72"	24"	17¾"	4.0 yds	65.0'	*118 lbs.	44.71'/1
451 mm	-	1836 mm	610 mm	451 mm	3.7 m	6.0 sqm	54.9 kg	1.3 cu.

COM	COL	1	2	3	4	5	6	7	8	9	10	11
2975	3055	3349	3411	3447	3518	3580	3607	3651	3713	3767	3829	4184

Pasadena 6SBS

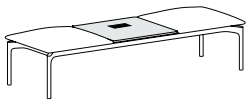

Power - black module
Two-seat bench with center table
Polished aluminum or powder coat base
Upholstered

End table available in phenolic and all oak and walnut finishes, except for walnut LV8. When specifying light finish the natural characteristics of the wood will be visible and color will vary.

Ganging brackets are sold separately and will ship with the product. See Pasadena accessories page to order brackets.

Power: Surface mount power provides (2) 15 amp receptacles and (2) 2 amp USB-C ports, 20 watt.

SCS Indoor Advantage™ Gold and LEVEL® 2 certified. See terms and conditions for additional environmental information.

*Weight shown represents shipping weight for wood top. Shipping weight for phenolic top is 127 lbs./58.0 cu.

Seat Height	Arm Height	W	D	H	Fabric	Leather	Weight	Cubes/Qty
17¾"	-	72"	24"	17¾"	4.0 yds	65.0'	*119 lbs.	44.71'/1
451 mm	-	1837 mm	610 mm	451 mm	3.7 m	6.0 sqm	54.1 kg	1.3 cu.

COM	COL	1	2	3	4	5	6	7	8	9	10	11
3443	3523	3817	3879	3915	3986	4048	4075	4119	4181	4235	4297	4652

sku	top material	base finish
	C oak	PA polished aluminum standard, OR
	9 walnut	
	phenolic upcharge \$650	specify powder coat, upcharge \$250
	W phenolic - white	WH satin white
	B phenolic - black	EC ecru
		LA latte
	X none	AL aluminum
		GR graphite
		BZ bronze
		SG sage
		IG iron grey
		RD black red
		BK matte black

Pasadena 6SWS

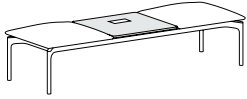

Power - white module
Two-seat bench with center table
Polished aluminum or powder coat base
Upholstered

End table available in phenolic and all oak and walnut finishes, except for walnut LV8. When specifying light finish the natural characteristics of the wood will be visible and color will vary.

Ganging brackets are sold separately and will ship with the product. See Pasadena accessories page to order brackets.

Power: Surface mount power provides (2) 15 amp receptacles and (2) 2 amp USB-C ports, 20 watt.

SCS Indoor Advantage™ Gold and LEVEL® 2 certified. See terms and conditions for additional environmental information.

*Weight shown represents shipping weight for wood top. Shipping weight for phenolic top is 127 lbs./58.0 cu.

Seat Height	Arm Height	W	D	H	Fabric	Leather	Weight	Cubes/Qty
17¾"	-	72"	24"	17¾"	4.0 yds	65.0'	*119 lbs.	44.71'/1
451 mm	-	1838 mm	610 mm	451 mm	3.7 m	6.0 sqm	54.1 kg	1.3 cu.

COM	COL	1	2	3	4	5	6	7	8	9	10	11
3443	3523	3817	3879	3915	3986	4048	4075	4119	4181	4235	4297	4652

sku	top material	base finish
	C oak	PA polished aluminum standard, OR
	9 walnut	
	phenolic upcharge \$650	specify powder coat, upcharge \$250
	W phenolic - white	WH satin white
	B phenolic - black	EC ecru
		LA latte
	X none	AL aluminum
		GR graphite
		BZ bronze
		SG sage
		IG iron grey
		RD black red
		BK matte black

Pasadena 6AAX

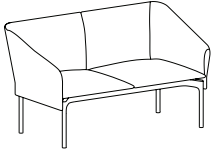

**Freestanding loveseat
Polished aluminum or powder coat base
Upholstered**

Inside seat width: 43"; Inside seat depth: 21"

Ganging brackets are sold separately and will ship with the product. See Pasadena accessories page to order brackets.

When using a combination of fabrics or leathers, specify the application by designating the appropriate letter, shown below, on the purchase order. Yardage shown must be used.

See terms and conditions for contrasting upholstery upcharges.

- A) One fabric or leather for seat
yardage: 3.0 yds. leather: 49.0 sq. ft.
- B) One fabric or leather for inside back and outside back
yardage: 7.0 yds. leather: 114.0 sq. ft.

SCS Indoor Advantage™ Gold and LEVEL® 2 certified. See terms and conditions for additional environmental information.

Seat Height	Arm Height	W	D	H	Fabric	Leather	Weight	Cubes/Qty
17¾"	27½"	55"	28"	31"	10.0 yds	162.0'	145 lbs.	50.90'/1
451 mm	699 mm	1397 mm	711 mm	787 mm	9.1 m	15.1 sqm	66.0 kg	1.44 cu.

COM	COL	1	2	3	4	5	6	7	8	9	10	11
4009	4209	4943	5098	5187	5365	5521	5587	5698	5854	5987	6143	7032

Pasadena 6ALA

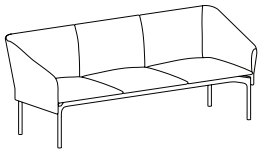

**Freestanding Sofa
Polished aluminum or powder coat base
Upholstered**

Inside seat depth: 21"; Inside seat width: 67¼"

Ganging brackets are sold separately and will ship with the product. See Pasadena accessories page to order brackets.

When using a combination of fabrics or leathers, specify the application by designating the appropriate letter, shown below, on the purchase order. Yardage shown must be used.

See terms and conditions for contrasting upholstery upcharges.

- A) One fabric or leather for seat
yardage: 5.25 yds. leather: 85.0 sq. ft.
- B) One fabric or leather for inside back and outside back
yardage: 8.5 yds. leather: 140.0 sq. ft.

SCS Indoor Advantage™ Gold and LEVEL® 2 certified. See terms and conditions for additional environmental information.

Seat Height	Arm Height	W	D	H	Fabric	Leather	Weight	Cubes/Qty
17¾"	27½"	79"	28"	31"	13.75 yds	223.0'	190 lbs.	68.93'/1
451 mm	699 mm	2007 mm	711 mm	787 mm	12.6 m	20.7 sqm	86.2 kg	2.0 cu.

COM	COL	1	2	3	4	5	6	7	8	9	10	11
5114	5389	6398	6612	6734	6978	7192	7284	7437	7651	7834	8048	9270

sku	top material	base finish
	C oak 9 walnut phenolic upcharge \$650 W phenolic - white B phenolic - black X none	PA polished aluminum standard, OR specify powder coat, upcharge \$250 WH satin white GR graphite RD black red EC ecru BZ bronze BK matte black LA latte SG sage AL aluminum IG iron grey

Pasadena 6LLX

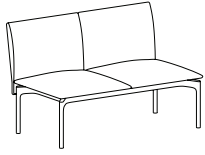

Two-seat armless module
Polished aluminum or powder coat base
Upholstered

Inside seat depth: 21"

Ganging brackets are sold separately and will ship with the product. See Pasadena accessories page to order brackets.

When using a combination of fabrics or leathers, specify the application by designating the appropriate letter, shown below, on the purchase order. Yardage shown must be used.

See terms and conditions for contrasting upholstery upcharges.

- A) One fabric or leather for seat
yardage: 4.25 yds. leather: 69.0 sq. ft.
- B) One fabric or leather for inside back and outside back
yardage: 3.75 yds. leather: 61.0 sq. ft.

SCS Indoor Advantage™ Gold certified. See terms and conditions for additional environmental information.

Seat Height	Arm Height	W	D	H	Fabric	Leather	Weight	Cubes/Qty
17¾"	-	48"	28"	31"	8.0 yds	130.0'	118 lbs.	50.70'/1
451 mm	-	1219 mm	711 mm	787 mm	7.3 m	12.1 sqm	54.9 kg	1.44 cu.

COM	COL	1	2	3	4	5	6	7	8	9	10	11
3418	3578	4165	4290	4361	4503	4627	4681	4770	4894	5001	5125	5836

sku	top material	base finish
	C oak	PA polished aluminum standard, OR
	9 walnut	
	phenolic upcharge \$650	specify powder coat, upcharge \$250
	W phenolic - white	WH satin white
	B phenolic - black	EC ecru
		LA latte
	X none	AL aluminum
		GR graphite
		BZ bronze
		SG sage
		IG iron grey
		RD black red
		BK matte black

Pasadena 6LSX

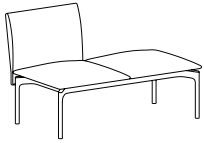

Two-seat armless open end module
Left side facing
Polished aluminum or powder coat base
Upholstered

Inside seat depth: 21"

Ganging brackets are sold separately and will ship with the product. See Pasadena accessories page to order brackets.

When using a combination of fabrics or leathers, specify the application by designating the appropriate letter, shown below, on the purchase order. Yardage shown must be used.

See terms and conditions for contrasting upholstery upcharges.

- A) One fabric or leather for seat
 yardage: 4.0 yds. leather: 65.0 sq. ft.
- B) One fabric or leather for inside back and outside back
 yardage: 2.0 yds. leather: 33.0 sq. ft.

SCS Indoor Advantage™ Gold certified. See terms and conditions for additional environmental information.

Seat Height	Arm Height	W	D	H	Fabric	Leather	Weight	Cubes/Qty
17¾"	-	48"	28"	31"	6.0 yds	98.0'	104 lbs.	50.70'/1
451 mm	-	1219 mm	711 mm	787 mm	5.5 m	9.1 sqm	47.2 kg	1.44 cu.

COM	COL	1	2	3	4	5	6	7	8	9	10	11
2811	2931	3371	3465	3518	3625	3718	3758	3825	3918	3998	4091	4625

sku	top material	base finish
	C oak	PA polished aluminum standard, OR
	9 walnut	
	phenolic upcharge \$650	specify powder coat, upcharge \$250
	W phenolic - white	WH satin white
	B phenolic - black	EC ecru
		LA latte
	X none	AL aluminum
		GR graphite
		BZ bronze
		SG sage
		IG iron grey
		RD black red
		BK matte black

Pasadena 6SLX

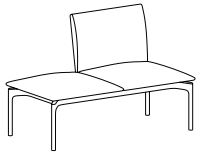

Two-seat armless open end module
Right side facing
Polished aluminum or powder coat base
Upholstered

Inside seat depth: 21"

Ganging brackets are sold separately and will ship with the product. See Pasadena accessories page to order brackets.

When using a combination of fabrics or leathers, specify the application by designating the appropriate letter, shown below, on the purchase order. Yardage shown must be used.

See terms and conditions for contrasting upholstery upcharges.

- A) One fabric or leather for seat
 yardage: 4.0 yds. leather: 65.0 sq. ft.
- B) One fabric or leather for inside back and outside back
 yardage: 2.0 yds. leather: 33.0 sq. ft.

SCS Indoor Advantage™ Gold certified. See terms and conditions for additional environmental information.

Seat Height	Arm Height	W	D	H	Fabric	Leather	Weight	Cubes/Qty
17¾"	-	48"	28"	31"	6.0 yds	98.0'	104 lbs.	50.70'/1
451 mm	-	1219 mm	711 mm	787 mm	5.5 m	9.1 sqm	47.2 kg	1.44 cu.

COM	COL	1	2	3	4	5	6	7	8	9	10	11
2811	2931	3371	3465	3518	3625	3718	3758	3825	3918	3998	4091	4625

sku	top material	base finish
	C oak	PA polished aluminum standard, OR
	9 walnut	
	phenolic upcharge \$650	specify powder coat, upcharge \$250
	W phenolic - white	WH satin white
	B phenolic - black	EC ecru
		LA latte
	X none	AL aluminum
		GR graphite
		BZ bronze
		SG sage
		IG iron grey
		RD black red
		BK matte black

Pasadena 6LTX

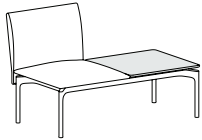

Armless module with end table
Left side facing
Polished aluminum or powder coat base
Upholstered

Inside seat depth: 21"

End table available in phenolic and all oak and walnut finishes, except for walnut LV8. When specifying light finish the natural characteristics of the wood will be visible and color will vary.

Ganging brackets are sold separately and will ship with the product. See Pasadena accessories page to order brackets.

When using a combination of fabrics or leathers, specify the application by designating the appropriate letter, shown below, on the purchase order. Yardage shown must be used.

See terms and conditions for contrasting upholstery upcharges.

- A) One fabric or leather for seat
 yardage: 2.5 yds. leather: 40.5 sq. ft.
- B) One fabric or leather for inside back and outside back
 yardage: 2.25 yds. leather: 37.0 sq. ft.

SCS Indoor Advantage™ Gold certified. See terms and conditions for additional environmental information.

*Weight shown represents shipping weight for wood top. Shipping weight for phenolic top is 116 lbs./7.3 kg.

Seat Height	Arm Height	W	D	H	Fabric	Leather	Weight	Cubes/Qty
17¾"	-	48"	28"	31"	4.75 yds	77.0'	*108 lbs.	50.70'/1
451 mm	-	1219 mm	711 mm	787 mm	4.3 m	7.2 sqm	49.0 kg	1.44 cu.

COM	COL	1	2	3	4	5	6	7	8	9	10	11
3245	3340	3689	3763	3805	3889	3963	3995	4048	4122	4185	4259	4681

sku	top material	base finish
	C oak	PA polished aluminum standard, OR
	9 walnut	
	phenolic upcharge \$650	specify powder coat, upcharge \$250
	W phenolic - white	WH satin white
	B phenolic - black	EC ecru
		LA latte
	X none	AL aluminum
		GR graphite
		BZ bronze
		SG sage
		IG iron grey
		RD black red
		BK matte black

Pasadena 6LBX



Power - black module
Armless module with end table
Left side facing
Polished aluminum or powder coat base
Upholstered

Inside seat depth: 21"

End table available in phenolic and all oak and walnut finishes, except for walnut LV8. When specifying light finish the natural characteristics of the wood will be visible and color will vary.

Ganging brackets are sold separately and will ship with the product. See Pasadena accessories page to order bracket.

Power: Surface mount power provides (2) 15 amp receptacles and (2) 2 amp USB-C ports, 20 watt.

When using a combination of fabrics or leathers, specify the application by designating the appropriate letter, shown below, on the purchase order. Yardage shown must be used.

See terms and conditions for contrasting upholstery upcharges.

- A) One fabric or leather for seat
 yardage: 2.5 yds. leather: 40.5 sq. ft.
- B) One fabric or leather for inside back and outside back
 yardage: 2.25 yds. leather: 37.0 sq. ft.

SCS Indoor Advantage™ Gold certified. See terms and conditions for additional environmental information.

*Weight shown represents shipping weight for wood top. Shipping weight for phenolic top is 117 lbs./53.1 kg.

Seat Height	Arm Height	W	D	H	Fabric	Leather	Weight	Cubes/Qty
17¾"	-	48"	28"	31"	4.75 yds	77.0'	*109 lbs.	50.70'/1
451mm	-	1219 mm	711 mm	787 mm	4.3 m	7.2 sqm	50.0 kg	1.44 cu.

COM	COL	1	2	3	4	5	6	7	8	9	10	11
3713	3808	4157	4231	4273	4357	4431	4463	4516	4590	4653	4727	5149

sku	top material	base finish
	C oak	PA polished aluminum standard, OR
	9 walnut	
	phenolic upcharge \$650	specify powder coat, upcharge \$250
	W phenolic - white	WH satin white
	B phenolic - black	EC ecru
		LA latte
	X none	AL aluminum
		GR graphite
		BZ bronze
		SG sage
		IG iron grey
		RD black red
		BK matte black

Pasadena 6LWX



Power - white module
Armless module with end table
Left side facing
White power module
Polished aluminum or powder coat base
Upholstered

Inside seat depth: 21"

End table available in phenolic and all oak and walnut finishes, except for walnut LV8. When specifying light finish the natural characteristics of the wood will be visible and color will vary.

Ganging brackets are sold separately and will ship with the product. See Pasadena accessories page to order bracket.

Power: Surface mount power provides (2) 15 amp receptacles and (2) 2 amp USB-C ports, 20 watt.

When using a combination of fabrics or leathers, specify the application by designating the appropriate letter, shown below, on the purchase order. Yardage shown must be used.

See terms and conditions for contrasting upholstery upcharges.

- A) One fabric or leather for seat
 yardage: 2.5 yds. leather: 40.5 sq. ft.
- B) One fabric or leather for inside back and outside back
 yardage: 2.25 yds. leather: 37.0 sq. ft.

SCS Indoor Advantage™ Gold certified. See terms and conditions for additional environmental information.

*Weight shown represents shipping weight for wood top. Shipping weight for phenolic top is 117 lbs./53.1 kg.

Seat Height	Arm Height	W	D	H	Fabric	Leather	Weight	Cubes/Qty
17¾"	-	48"	28"	31"	4.75 yds	77.0'	*109 lbs.	50.70/1
451mm	-	1219 mm	711 mm	787 mm	4.3 m	7.2 sqm	50.0 kg	1.44 cu.

COM	COL	1	2	3	4	5	6	7	8	9	10	11
3713	3808	4157	4231	4273	4357	4431	4463	4516	4590	4653	4727	5149

sku	top material	base finish
	C oak	PA polished aluminum standard, OR
	9 walnut	
	phenolic upcharge \$650	specify powder coat, upcharge \$250
	W phenolic - white	WH satin white
	B phenolic - black	EC ecru
	X none	LA latte
		AL aluminum
		GR graphite
		BZ bronze
		SG sage
		IG iron grey
		RD black red
		BK matte black

Pasadena 6TLX

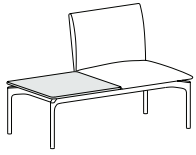

Armless module with end table
Right side facing
Polished aluminum or powder coat base
Upholstered

End table available in phenolic and all oak and walnut finishes, except for walnut LV8. When specifying light finish the natural characteristics of the wood will be visible and color will vary.

Ganging brackets are sold separately and will ship with the product. See Pasadena accessories page to order brackets.

When using a combination of fabrics or leathers, specify the application by designating the appropriate letter, shown below, on the purchase order. Yardage shown must be used.

See terms and conditions for contrasting upholstery upcharges.

- A) One fabric or leather for seat
 yardage: 2.5 yds. leather: 40.5 sq. ft.
- B) One fabric or leather for inside back and outside back
 yardage: 2.25 yds. leather: 37.0 sq. ft.

SCS Indoor Advantage™ Gold certified. See terms and conditions for additional environmental information.

*Weight shown represents shipping weight for wood top. Shipping weight for phenolic top is 116 lbs./7.3 kg.

Seat Height	Arm Height	W	D	H	Fabric	Leather	Weight	Cubes/Qty
17¾"	-	48"	28"	31"	4.75 yds	77.0'	*108 lbs.	50.70'/1
451 mm	-	1219 mm	711 mm	787 mm	4.3 m	7.2 sqm	49.0 kg	1.44 cu.

COM	COL	1	2	3	4	5	6	7	8	9	10	11
3245	3340	3689	3763	3805	3889	3963	3995	4048	4122	4185	4259	4681

sku	top material	base finish
	C oak	PA polished aluminum standard, OR
	9 walnut	
	phenolic upcharge \$650	specify powder coat, upcharge \$250
	W phenolic - white	WH satin white
	B phenolic - black	EC ecru
	X none	LA latte
		AL aluminum
		GR graphite
		BZ bronze
		SG sage
		IG iron grey
		RD black red
		BK matte black

Pasadena 6BLX

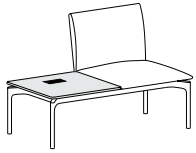

Power - black module
Armless module with end table
Right side facing
Polished aluminum or powder coat base
Upholstered

End table available in phenolic and all oak and walnut finishes, except for walnut LV8. When specifying light finish the natural characteristics of the wood will be visible and color will vary.

Ganging brackets are sold separately and will ship with the product. See Pasadena accessories page to order bracket.

Power: Surface mount power provides (2) 15 amp receptacles and (2) 2 amp USB-C ports, 20 watt.

When using a combination of fabrics or leathers, specify the application by designating the appropriate letter, shown below, on the purchase order. Yardage shown must be used.

See terms and conditions for contrasting upholstery upcharges.

- A) One fabric or leather for seat
 yardage: 2.5 yds. leather: 40.5 sq. ft.
- B) One fabric or leather for inside back and outside back
 yardage: 2.25 yds. leather: 37.0 sq. ft.

SCS Indoor Advantage™ Gold certified. See terms and conditions for additional environmental information.

*Weight shown represents shipping weight for wood top. Shipping weight for phenolic top is 117 lbs./53.1 kg.

Seat Height	Arm Height	W	D	H	Fabric	Leather	Weight	Cubes/Qty
17¾"	-	48"	28"	31"	4.75 yds	77.0'	*109 lbs.	50.70'/1
451 mm	-	1219 mm	711 mm	787 mm	4.3 m	7.2 sqm	50.0 kg.	1.44 cu.

COM	COL	1	2	3	4	5	6	7	8	9	10	11
3713	3808	4157	4231	4273	4357	4431	4463	4516	4590	4653	4727	5149

sku	top material	base finish
	C oak	PA polished aluminum standard, OR
	9 walnut	
	phenolic upcharge \$650	specify powder coat, upcharge \$250
	W phenolic - white	WH satin white
	B phenolic - black	EC ecru
		LA latte
	X none	AL aluminum
		GR graphite
		BZ bronze
		SG sage
		IG iron grey
		RD black red
		BK matte black

Pasadena 6WLX

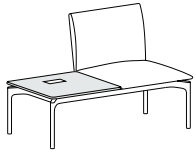

Power - white module
Armless module with end table
Right side facing
Polished aluminum or powder coat base
Upholstered

Inside seat depth: 21"

End table available in phenolic and all oak and walnut finishes, except for walnut LV8. When specifying light finish the natural characteristics of the wood will be visible and color will vary.

Ganging brackets are sold separately and will ship with the product. See Pasadena accessories page to order bracket.

Power: Surface mount power provides (2) 15 amp receptacles and (2) 2 amp USB-C ports, 20 watt.

When using a combination of fabrics or leathers, specify the application by designating the appropriate letter, shown below, on the purchase order. Yardage shown must be used.

See terms and conditions for contrasting upholstery upcharges.

- A) One fabric or leather for seat
 yardage: 2.5 yds. leather: 40.5 sq. ft.
- B) One fabric or leather for inside back and outside back
 yardage: 2.25 yds. leather: 37.0 sq. ft.

SCS Indoor Advantage™ Gold certified. See terms and conditions for additional environmental information.

*Weight shown represents shipping weight for wood top. Shipping weight for Phenolic top is 117 lbs./53.1 kg.

Seat Height	Arm Height	W	D	H	Fabric	Leather	Weight	Cubes/Qty
17¾"	-	48"	28"	31"	4.75 yds	77.0'	*109 lbs.	50.70'/1
451 mm	-	1219 mm	711 mm	787 mm	4.3 m	7.2 sqm	50.0 kg	1.44 cu.

COM	COL	1	2	3	4	5	6	7	8	9	10	11
3713	3808	4157	4231	4273	4357	4431	4463	4516	4590	4653	4727	5149

sku	top material	base finish
	C oak	PA polished aluminum standard, OR
	9 walnut	
	phenolic upcharge \$650	specify powder coat, upcharge \$250
	W phenolic - white	WH satin white
	B phenolic - black	EC ecru
		LA latte
	X none	AL aluminum
		GR graphite
		BZ bronze
		SG sage
		IG iron grey
		RD black red
		BK matte black

Pasadena 6ALX

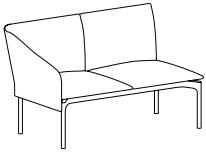

Two-seat module
Left side facing
Polished aluminum or powder coat base
Upholstered

Inside seat depth: 21"

Ganging brackets are sold separately and will ship with the product. See Pasadena accessories page to order brackets.

When using a combination of fabrics or leathers, specify the application by designating the appropriate letter, shown below, on the purchase order. Yardage shown must be used.

See terms and conditions for contrasting upholstery upcharges.

- A) One fabric or leather for seat
yardage: 3.5 yds. leather: 57.0 sq. ft.
- B) One fabric or leather for inside back and outside back
yardage: 5.5 yds. leather: 90.0 sq. ft.

SCS Indoor Advantage™ Gold certified. See terms and conditions for additional environmental information.

Seat Height	Arm Height	W	D	H	Fabric	Leather	Weight	Cubes/Qty
17¾"	27½"	51½"	28"	31"	9.0 yds	146.0'	121 lbs.	50.70'/1
451 mm	699 mm	1308 mm	711 mm	787 mm	8.2 m	13.6 sqm	55.0	1.44 cu.

COM	COL	1	2	3	4	5	6	7	8	9	10	11
3714	3894	4554	4694	4774	4934	5074	5134	5234	5374	5494	5634	6434

sku	top material	base finish
	C oak	PA polished aluminum standard, OR
	9 walnut	
	phenolic upcharge \$650	specify powder coat, upcharge \$250
	W phenolic - white	WH satin white
	B phenolic - black	EC ecru
	X none	LA latte
		AL aluminum
		GR graphite
		BZ bronze
		SG sage
		IG iron grey
		RD black red
		BK matte black

Pasadena 6LAX

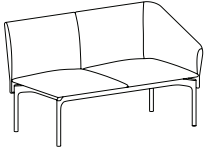

Two-seat module
Right side facing
Polished aluminum or powder coat base
Upholstered

Inside seat depth: 21"

Ganging brackets are sold separately and will ship with the product. See Pasadena accessories page to order brackets.

When using a combination of fabrics or leathers, specify the application by designating the appropriate letter, shown below, on the purchase order. Yardage shown must be used.

See terms and conditions for contrasting upholstery upcharges.

- A) One fabric or leather for seat
 yardage: 3.5 yds. leather: 57.0 sq. ft.
- B) One fabric or leather for inside back and outside back
 yardage: 5.5 yds. leather: 90.0 sq. ft.

SCS Indoor Advantage™ Gold certified. See terms and conditions for additional environmental information.

Seat Height	Arm Height	W	D	H	Fabric	Leather	Weight	Cubes/Qty
17¾"	27½"	51½"	28"	31"	9.0 yds	146.0'	121 lbs.	50.70'/1
451 mm	699 mm	1308 mm	711 mm	787 mm	8.2 m	13.6 sqm	55.0 kg	1.44 cu.

COM	COL	1	2	3	4	5	6	7	8	9	10	11
3714	3894	4554	4694	4774	4934	5074	5134	5234	5374	5494	5634	6434

sku	top material	base finish
	C oak	PA polished aluminum standard, OR
	9 walnut	
	phenolic upcharge \$650	specify powder coat, upcharge \$250
	W phenolic - white	WH satin white
	B phenolic - black	EC ecru
		LA latte
	X none	AL aluminum
		GR graphite
		BZ bronze
		SG sage
		IG iron grey
		RD black red
		BK matte black

Pasadena 6LLL

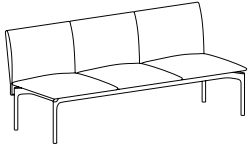

Three-seat armless module
Polished aluminum or powder coat base
Upholstered

Inside seat depth: 21"

Ganging brackets are sold separately and will ship with the product. See Pasadena accessories page to order brackets.

When using a combination of fabrics or leathers, specify the application by designating the appropriate letter, shown below, on the purchase order. Yardage shown must be used.

See terms and conditions for contrasting upholstery upcharges.

- A) One fabric or leather for seat
yardage: 6.25 yds. leather: 102.0 sq. ft.
- B) One fabric or leather for inside back and outside back
yardage: 5.5 yds. leather: 89.0 sq. ft.

SCS Indoor Advantage™ Gold certified. See terms and conditions for additional environmental information.

Seat Height	Arm Height	W	D	H	Fabric	Leather	Weight	Cubes/Qty
17¾"	-	72"	28"	31"	11.75 yds	191.0'	164 lbs.	68.93'/1
451 mm	-	1829 mm	711 mm	787 mm	10.7 m	17.7 sqm	74.4 kg	2.0 cu.

COM	COL	1	2	3	4	5	6	7	8	9	10	11
4522	4757	5619	5802	5906	6115	6298	6376	6507	6690	6846	7029	8074

sku	top material	base finish
	C oak	PA polished aluminum standard, OR
	9 walnut	
	phenolic upcharge \$650	specify powder coat, upcharge \$250
	W phenolic - white	WH satin white
	B phenolic - black	EC ecru
		LA latte
	X none	AL aluminum
		GR graphite
		BZ bronze
		SG sage
		IG iron grey
		RD black red
		BK matte black

Pasadena 6LLS

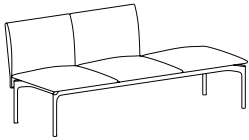

Three-seat armless open end module
Left side facing
Polished aluminum or powder coat base
Upholstered

Inside seat depth: 21"

Ganging brackets are sold separately and will ship with the product. See Pasadena accessories page to order brackets.

When using a combination of fabrics or leathers, specify the application by designating the appropriate letter, shown below, on the purchase order. Yardage shown must be used.

See terms and conditions for contrasting upholstery upcharges.

- A) One fabric or leather for seat
 yardage: 5.75 yds. leather: 94.0 sq. ft.
- B) One fabric or leather for inside back and outside back
 yardage: 4.0 yds. leather: 65.0 sq. ft.

SCS Indoor Advantage™ Gold certified. See terms and conditions for additional environmental information.

Seat Height	Arm Height	W	D	H	Fabric	Leather	Weight	Cubes/Qty
17¾"	-	72"	28"	31"	9.75 yds	158.0'	149 lbs.	68.93'/1
451 mm	-	1829 mm	711 mm	787 mm	9.0 m	14.7 sqm	68.0 kg	2.0 cu.

COM	COL	1	2	3	4	5	6	7	8	9	10	11
3917	4112	4827	4979	5066	5239	5391	5456	5564	5716	5846	5997	6864

sku	top material	base finish
	C oak	PA polished aluminum standard, OR
	9 walnut	
	phenolic upcharge \$650	specify powder coat, upcharge \$250
	W phenolic - white	WH satin white
	B phenolic - black	EC ecru
		LA latte
	X none	AL aluminum
		GR graphite
		BZ bronze
		SG sage
		IG iron grey
		RD black red
		BK matte black

Pasadena 6SLL

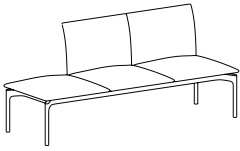

Three-seat armless open end module
Right side facing
Polished aluminum or powder coat base
Upholstered

Inside seat depth: 21"

Ganging brackets are sold separately and will ship with the product. See Pasadena accessories page to order brackets.

When using a combination of fabrics or leathers, specify the application by designating the appropriate letter, shown below, on the purchase order. Yardage shown must be used.

See terms and conditions for contrasting upholstery upcharges.

- A) One fabric or leather for seat
 yardage: 5.75 yds. leather: 94.0 sq. ft.
- B) One fabric or leather for inside back and outside back
 yardage: 4.0 yds. leather: 65.0 sq. ft.

SCS Indoor Advantage™ Gold certified. See terms and conditions for additional environmental information.

Seat Height	Arm Height	W	D	H	Fabric	Leather	Weight	Cubes/Qty
17¾"	-	72"	28"	31"	9.75 yds	158.0'	149 lbs.	68.93/1
451 mm	-	1829 mm	711 mm	787 mm	9.0 m	14.7 sqm	68.0 kg	2.0 cu.

COM	COL	1	2	3	4	5	6	7	8	9	10	11
3917	4112	4827	4979	5066	5239	5391	5456	5564	5716	5846	5997	6864

sku	top material	base finish
	C oak	PA polished aluminum standard, OR
	9 walnut	
	phenolic upcharge \$650	specify powder coat, upcharge \$250
	W phenolic - white	WH satin white
	B phenolic - black	EC ecru
		LA latte
	X none	AL aluminum
		GR graphite
		BZ bronze
		SG sage
		IG iron grey
		RD black red
		BK matte black

Pasadena 6LLT

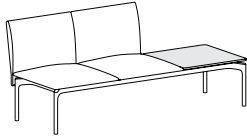

Two-seat armless module with end table
Left side facing
Polished aluminum or powder coat base
Upholstered

End table available in phenolic and all oak and walnut finishes, except for walnut LV8. When specifying light finish the natural characteristics of the wood will be visible and color will vary.

Inside seat depth: 21"

Ganging brackets are sold separately and will ship with the product. See Pasadena accessories page to order brackets.

When using a combination of fabrics or leathers, specify the application by designating the appropriate letter, shown below, on the purchase order. Yardage shown must be used.

See terms and conditions for contrasting upholstery upcharges.

- A) One fabric or leather for seat
 yardage: 4.5 yds. leather: 73.0 sq. ft.
- B) One fabric or leather for inside back and outside back
 yardage: 4.0 yds. leather: 65.0 sq. ft.

SCS Indoor Advantage™ Gold certified. See terms and conditions for additional environmental information.

*Weight shown represents shipping weight for wood top. Shipping weight for phenolic top is 162 lbs./73.5 kg.

Seat Height	Arm Height	W	D	H	Fabric	Leather	Weight	Cubes/Qty
17¾"	-	72"	28"	31"	8.5 yds	138.0'	*154 lbs.	68.93/1
451 mm	-	1829 mm	711 mm	787 mm	7.8 m	12.8 sqm	70.0 kg	2.0 cu.

COM	COL	1	2	3	4	5	6	7	8	9	10	11
4349	4519	5143	5275	5351	5502	5634	5691	5785	5917	6031	6163	6918

sku	top material	base finish
	C oak	PA polished aluminum standard, OR
	9 walnut	
	phenolic upcharge \$650	specify powder coat, upcharge \$250
	W phenolic - white	WH satin white
	B phenolic - black	EC ecru
		LA latte
	X none	AL aluminum
		GR graphite
		BZ bronze
		SG sage
		IG iron grey
		RD black red
		BK matte black

Pasadena 6LLB

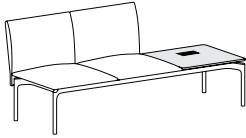

Power - black module
Two-seat armless module with end table
Left side facing
Polished aluminum or powder coat base
Upholstered

End table available in phenolic and all oak and walnut finishes, except for walnut LV8. When specifying light finish the natural characteristics of the wood will be visible and color will vary.

Inside seat depth: 21"

Ganging brackets are sold separately and will ship with the product. See Pasadena accessories page to order brackets.

Power: Surface mount power provides (2) 15 amp receptacles and (2) 2 amp USB-C ports, 20 watt.

When using a combination of fabrics or leathers, specify the application by designating the appropriate letter, shown below, on the purchase order. Yardage shown must be used.

See terms and conditions for contrasting upholstery upcharges.

- A) One fabric or leather for seat
 yardage: 4.5 yds. leather: 73.0 sq. ft.
- B) One fabric or leather for inside back and outside back
 yardage: 4.0 yds. leather: 65.0 sq. ft.

SCS Indoor Advantage™ Gold certified. See terms and conditions for additional environmental information.

*Weight shown represents shipping weight for wood top. Shipping weight for phenolic top is 163 lbs./74.0 kg.

Seat Height	Arm Height	W	D	H	Fabric	Leather	Weight	Cubes/Qty
17¾"	-	72"	28"	31"	8.5 yds	138.0'	*155 lbs.	68.93/1
451 mm	-	1829 mm	711 mm	787 mm	7.8 m	12.8 sqm	70.3 kg	2.0 cu.

COM	COL	1	2	3	4	5	6	7	8	9	10	11
4817	4987	5611	5743	5819	5970	6102	6159	6253	6385	6499	6631	7386

sku	top material	base finish
	C oak	PA polished aluminum standard, OR
	9 walnut	
	phenolic upcharge \$650	specify powder coat, upcharge \$250
	W phenolic - white	WH satin white
	B phenolic - black	EC ecru
		LA latte
	X none	AL aluminum
		GR graphite
		BZ bronze
		SG sage
		IG iron grey
		RD black red
		BK matte black

Pasadena 6LLW

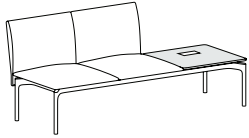

Power - white module
Two-seat armless module with end table
Left side facing
Polished aluminum or powder coat base
Upholstered

End table available in phenolic and all oak and walnut finishes, except for walnut LV8. When specifying light finish the natural characteristics of the wood will be visible and color will vary.

Inside seat depth: 21"

Ganging brackets are sold separately and will ship with the product. See Pasadena accessories page to order bracket.

Power: Surface mount power provides (2) 15 amp receptacles and (2) 2 amp USB-C ports, 20 watt.

When using a combination of fabrics or leathers, specify the application by designating the appropriate letter, shown below, on the purchase order. Yardage shown must be used.

See terms and conditions for contrasting upholstery upcharges.

- A) One fabric or leather for seat
 yardage: 4.5 yds. leather: 73.0 sq. ft.
- B) One fabric or leather for inside back and outside back
 yardage: 4.0 yds. leather: 65.0 sq. ft.

SCS Indoor Advantage™ Gold certified. See terms and conditions for additional environmental information.

*Weight shown represents shipping weight for wood top. Shipping weight for phenolic top is 163 lbs./74.0 kg.

Seat Height	Arm Height	W	D	H	Fabric	Leather	Weight	Cubes/Qty
17¾"	-	72"	28"	31"	8.5 yds	138.0'	*155 lbs.	68.93/1
451 mm	-	1829 mm	711 mm	787 mm	7.8 m	12.8 sqm	70.3 kg	2.0 cu

COM	COL	1	2	3	4	5	6	7	8	9	10	11
4817	4987	5611	5743	5819	5970	6102	6159	6253	6385	6499	6631	7386

sku	top material	base finish
	C oak	PA polished aluminum standard, OR
	9 walnut	
	phenolic upcharge \$650	specify powder coat, upcharge \$250
	W phenolic - white	WH satin white
	B phenolic - black	EC ecru
		LA latte
	X none	AL aluminum
		GR graphite
		BZ bronze
		SG sage
		IG iron grey
		RD black red
		BK matte black

Pasadena 6TLL

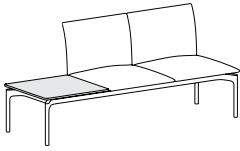

Two-seat armless module with end table
Right side facing
Polished aluminum or powder coat base
Upholstered

End table available in phenolic and all oak and walnut finishes, except for walnut LV8. When specifying light finish the natural characteristics of the wood will be visible and color will vary.

Inside seat depth: 21"

Ganging brackets are sold separately and will ship with the product. See Pasadena accessories page to order brackets.

When using a combination of fabrics or leathers, specify the application by designating the appropriate letter, shown below, on the purchase order. Yardage shown must be used.

See terms and conditions for contrasting upholstery upcharges.

- A) One fabric or leather for seat
 yardage: 4.5 yds. leather: 73.0 sq. ft.
- B) One fabric or leather for inside back and outside back
 yardage: 4.0 yds. leather: 65.0 sq. ft.

SCS Indoor Advantage™ Gold certified. See terms and conditions for additional environmental information.

*Weight shown represents shipping weight for wood top. Shipping weight for phenolic top is 162 lbs./73.5 kg.

Seat Height	Arm Height	W	D	H	Fabric	Leather	Weight	Cubes/Qty
17¾"	-	72"	28"	31"	8.5 yds	138.0'	*154 lbs.	68.93/1
451 mm	-	1829 mm	711 mm	787 mm	7.8 m	12.8 sqm	70.0 kg	2.0 cu.

COM	COL	1	2	3	4	5	6	7	8	9	10	11
4349	4519	5143	5275	5351	5502	5634	5691	5785	5917	6031	6163	6918

sku	top material	base finish
	C oak	PA polished aluminum standard, OR
	9 walnut	
	phenolic upcharge \$650	specify powder coat, upcharge \$250
	W phenolic - white	WH satin white
	B phenolic - black	EC ecru
		LA latte
	X none	AL aluminum
		GR graphite
		BZ bronze
		SG sage
		IG iron grey
		RD black red
		BK matte black

Pasadena 6BLL

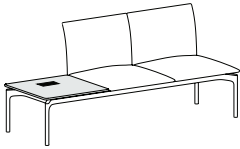

Power - black module
Two-seat armless module with end table
Right side facing
Polished aluminum or powder coat base
Upholstered

Inside seat depth: 21"

End table available in phenolic and all oak and walnut finishes, except for walnut LV8. When specifying light finish the natural characteristics of the wood will be visible and color will vary.

Ganging brackets are sold separately and will ship with the product. See Pasadena accessories page to order bracket.

Power: Surface mount power provides (2) 15 amp receptacles and (2) 2 amp USB-C ports, 20 watt.

When using a combination of fabrics or leathers, specify the application by designating the appropriate letter, shown below, on the purchase order. Yardage shown must be used.

See terms and conditions for contrasting upholstery upcharges.

- A) One fabric or leather for seat
 yardage: 4.5 yds. leather: 73.0 sq. ft.
- B) One fabric or leather for inside back and outside back
 yardage: 4.0 yds. leather: 65.0 sq. ft.

SCS Indoor Advantage™ Gold certified. See terms and conditions for additional environmental information.

*Weight shown represents shipping weight for wood top. Shipping weight for phenolic top is 163 lbs./74.0 kg.

Seat Height	Arm Height	W	D	H	Fabric	Leather	Weight	Cubes/Qty
17¾"	-	72"	28"	31"	8.5 yds	138.0'	*155 lbs.	68.93/1
451 mm	-	1829 mm	711 mm	787 mm	7.8 m	12.8 sqm	70.3 kg	2.0 cu.

COM	COL	1	2	3	4	5	6	7	8	9	10	11
4817	4987	5611	5743	5819	5970	6102	6159	6253	6385	6499	6631	7386

sku	top material	base finish
	C oak	PA polished aluminum standard, OR
	9 walnut	
	phenolic upcharge \$650	specify powder coat, upcharge \$250
	W phenolic - white	WH satin white
	B phenolic - black	EC ecru
		LA latte
	X none	AL aluminum
		GR graphite
		BZ bronze
		SG sage
		IG iron grey
		RD black red
		BK matte black

Pasadena 6WLL

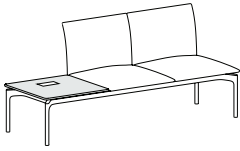

Power - white module
Two-seat armless module with end table
Right side facing
Polished aluminum or powder coat base
Upholstered

Inside seat depth: 21"

End table available in phenolic and all oak and walnut finishes, except for walnut LV8. When specifying light finish the natural characteristics of the wood will be visible and color will vary.

Ganging brackets are sold separately and will ship with the product. See Pasadena accessories page to order bracket.

Power: Surface mount power provides (2) 15 amp receptacles and (2) 2 amp USB-C ports, 20 watt.

When using a combination of fabrics or leathers, specify the application by designating the appropriate letter, shown below, on the purchase order. Yardage shown must be used.

See terms and conditions for contrasting upholstery upcharges.

- A) One fabric or leather for seat
 yardage: 4.5 yds. leather: 73.0 sq. ft.
- B) One fabric or leather for inside back and outside back
 yardage: 4.0 yds. leather: 65.0 sq. ft.

SCS Indoor Advantage™ Gold certified. See terms and conditions for additional environmental information.

*Weight shown represents shipping weight for wood top. Shipping weight for phenolic top is 163 lbs/74.0 kg.

Seat Height	Arm Height	W	D	H	Fabric	Leather	Weight	Cubes/Qty
17¾"	-	72"	28"	31"	8.5 yds	138.0'	*155 lbs.	68.93/1
451 mm	-	1829 mm	711 mm	787 mm	7.8 m	12.8 sqm	70.3 kg	2.0 cu.

COM	COL	1	2	3	4	5	6	7	8	9	10	11
4817	4987	5611	5743	5819	5970	6102	6159	6253	6385	6499	6631	7386

sku	top material	base finish
	C oak	PA polished aluminum standard, OR
	9 walnut	
	phenolic upcharge \$650	specify powder coat, upcharge \$250
	W phenolic - white	WH satin white
	B phenolic - black	EC ecru
		LA latte
	X none	AL aluminum
		GR graphite
		BZ bronze
		SG sage
		IG iron grey
		RD black red
		BK matte black

Pasadena 6LTL

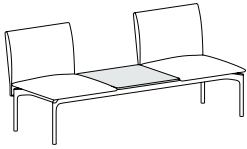

Two-seat armless module with center table
Polished aluminum or powder coat base
Upholstered

Inside seat depth: 21"

End table available in phenolic and all oak and walnut finishes, except for walnut LV8. When specifying light finish the natural characteristics of the wood will be visible and color will vary.

Ganging brackets are sold separately and will ship with the product. See Pasadena accessories page to order brackets.

When using a combination of fabrics or leathers, specify the application by designating the appropriate letter, shown below, on the purchase order. Yardage shown must be used.

See terms and conditions for contrasting upholstery upcharges.

- A) One fabric or leather for seat
yardage: 4.5 yds. leather: 73.0 sq. ft.
- B) One fabric or leather for inside back and outside back
yardage: 4.0 yds. leather: 65.0 sq. ft.

SCS Indoor Advantage™ Gold certified. See terms and conditions for additional environmental information.

*Weight shown represents shipping weight for wood top. Shipping weight for phenolic top is 162 lbs./73.5 kg.

Seat Height	Arm Height	W	D	H	Fabric	Leather	Weight	Cubes/Qty
17¾"	-	72"	28"	31"	8.5 yds	138.0'	*154 lbs.	68.93'/1
451 mm	-	1829 mm	711 mm	787 mm	7.8 m	12.8 sqm	70.0 kg	2.0 cu.

COM	COL	1	2	3	4	5	6	7	8	9	10	11
4349	4519	5143	5275	5351	5502	5634	5691	5785	5917	6031	6163	6918

sku	top material	base finish
	C oak	PA polished aluminum standard, OR
	9 walnut	
	phenolic upcharge \$650	specify powder coat, upcharge \$250
	W phenolic - white	WH satin white
	B phenolic - black	EC ecru
		LA latte
	X none	AL aluminum
		GR graphite
		BZ bronze
		SG sage
		IG iron grey
		RD black red
		BK matte black

Pasadena 6LBL

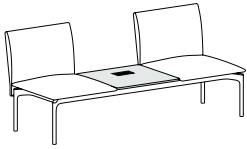

Power - black module
Two-seat armless module with center table
Polished aluminum or powder coat base
Upholstered

Center table available in phenolic and all oak and walnut finishes, except for walnut LV8. When specifying light finish the natural characteristics of the wood will be visible and color will vary.

Inside seat depth: 21"

Ganging brackets are sold separately and will ship with the product. See Pasadena accessories page to order bracket.

Power: Surface mount power provides (2) 15 amp receptacles and (2) 2 amp USB-C ports, 20 watt

When using a combination of fabrics or leathers, specify the application by designating the appropriate letter, shown below, on the purchase order. Yardage shown must be used.

See terms and conditions for contrasting upholstery upcharges.

- A) One fabric or leather for seat
 yardage: 4.5 yds. leather: 73.0 sq. ft.
- B) One fabric or leather for inside back and outside back
 yardage: 4.0 yds. leather: 65.0 sq. ft.

SCS Indoor Advantage™ Gold certified. See terms and conditions for additional environmental information.

*Weight shown represents shipping weight for wood top. Shipping weight for phenolic top is 163 lbs./74.0 kg.

Seat Height	Arm Height	W	D	H	Fabric	Leather	Weight	Cubes/Qty
17¾"	-	72"	28"	31"	8.5 yds	138.0'	155 lbs.	68.93'/1
451 mm	-	1829 mm	711 mm	787 mm	7.8 m	12.8 sqm	70.3 kg	2.0 cu.

COM	COL	1	2	3	4	5	6	7	8	9	10	11
4817	4987	5611	5743	5819	5970	6102	6159	6253	6385	6499	6631	7386

sku	top material	base finish
	C oak	PA polished aluminum standard, OR
	9 walnut	
	phenolic upcharge \$650	specify powder coat, upcharge \$250
	W phenolic - white	WH satin white
	B phenolic - black	EC ecru
		LA latte
	X none	AL aluminum
		GR graphite
		BZ bronze
		SG sage
		IG iron grey
		RD black red
		BK matte black

Pasadena 6LWL

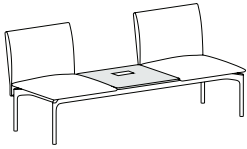

Power - white module
Two-seat armless module with center table
Polished aluminum or powder coat base
Upholstered

Center table available in phenolic and all oak and walnut finishes, except for walnut LV8. When specifying light finish the natural characteristics of the wood will be visible and color will vary.

Inside seat depth: 21"

Ganging brackets are sold separately and will ship with the product. See Pasadena accessories page to order bracket.

Power: Surface mount power provides (2) 15 amp receptacles and (2) 2 amp USB-C ports, 20 watt.

When using a combination of fabrics or leathers, specify the application by designating the appropriate letter, shown below, on the purchase order. Yardage shown must be used.

See terms and conditions for contrasting upholstery upcharges.

- A) One fabric or leather for seat
 yardage: 4.5 yds. leather: 73.0 sq. ft.
- B) One fabric or leather for inside back and outside back
 yardage: 4.0 yds. leather: 65.0 sq. ft.

SCS Indoor Advantage™ Gold certified. See terms and conditions for additional environmental information.

*Weight shown represents shipping weight for wood top. Shipping weight for phenolic top is 163 lbs./74.0 kg.

Seat Height	Arm Height	W	D	H	Fabric	Leather	Weight	Cubes/Qty
17¾"	-	72"	28"	31"	8.5 yds	138.0'	*155 lbs.	68.93'/1
451 mm	-	1829 mm	711 mm	787 mm	7.8 m	12.8 sqm	70.3 kg	2.0 cu.

COM	COL	1	2	3	4	5	6	7	8	9	10	11
4817	4987	5611	5743	5819	5970	6102	6159	6253	6385	6499	6631	7386

sku	top material	base finish
	C oak	PA polished aluminum standard, OR
	9 walnut	
	phenolic upcharge \$650	specify powder coat, upcharge \$250
	W phenolic - white	WH satin white
	B phenolic - black	EC ecru
		LA latte
	X none	AL aluminum
		GR graphite
		BZ bronze
		SG sage
		IG iron grey
		RD black red
		BK matte black

Pasadena 6LTS

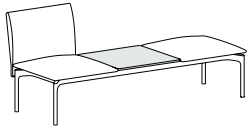

Two-seat armless open end module with center table
Left side facing
Polished aluminum or powder coat base
Upholstered

Center table available in phenolic and all oak and walnut finishes, except for walnut LV8. When specifying light finish the natural characteristics of the wood will be visible and color will vary.

Ganging brackets are sold separately and will ship with the product. See Pasadena accessories page to order brackets.

When using a combination of fabrics or leathers, specify the application by designating the appropriate letter, shown below, on the purchase order. Yardage shown must be used.

See terms and conditions for contrasting upholstery upcharges.

- A) One fabric or leather for seat
 yardage: 4.5 yds. leather: 73.0 sq. ft.
- B) One fabric or leather for inside back and outside back
 yardage: 2.0 yds. leather: 33.0 sq. ft.

SCS Indoor Advantage™ Gold certified. See terms and conditions for additional environmental information.

*Weight shown represents shipping weight for wood top. Shipping weight for phenolic top is 147 lbs./67.0 kg.

Seat Height	Arm Height	W	D	H	Fabric	Leather	Weight	Cubes/Qty
17¾"	-	72"	28"	31"	6.5 yds	106.0'	*139 lbs.	68.93/1
451 mm	-	1829 mm	711 mm	787 mm	5.9 m	9.8 sqm	63.0 kg	2.0 cu.

COM	COL	1	2	3	4	5	6	7	8	9	10	11
3743	3873	4350	4451	4509	4625	4726	4769	4841	4942	5029	5130	5708

sku	top material	base finish
	C oak	PA polished aluminum standard, OR
	9 walnut	
	phenolic upcharge \$650	specify powder coat, upcharge \$250
	W phenolic - white	WH satin white
	B phenolic - black	EC ecru
		LA latte
	X none	AL aluminum
		GR graphite
		BZ bronze
		SG sage
		IG iron grey
		RD black red
		BK matte black

Pasadena 6LBS

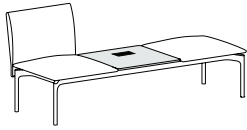

Power - black module
Two-seat armless open end module with center table
Left side facing
Polished aluminum or powder coat base
Upholstered

Center table available in phenolic and all oak and walnut finishes, except for walnut LV8. When specifying light finish the natural characteristics of the wood will be visible and color will vary.

Inside seat depth: 21"

Ganging brackets are sold separately and will ship with the product. See Pasadena accessories page to order bracket.

Power: Surface mount power provides (2) 15 amp receptacles and (2) 2 amp USB-C ports, 20 watt.

When using a combination of fabrics or leathers, specify the application by designating the appropriate letter, shown below, on the purchase order. Yardage shown must be used.

See terms and conditions for contrasting upholstery upcharges.

- A) One fabric or leather for seat
 yardage: 4.5 yds. leather: 73.0 sq. ft.
- B) One fabric or leather for inside back and outside back
 yardage: 2.0 yds. leather: 33.0 sq. ft.

SCS Indoor Advantage™ Gold certified. See terms and conditions for additional environmental information.

*Weight shown represents shipping weight for wood top. Shipping weight for phenolic top is 148 lbs./67.1 kg.

Seat Height	Arm Height	W	D	H	Fabric	Leather	Weight	Cubes/Qty
17¾"	-	72"	28"	31"	6.5 yds	106.0'	*140 lbs.	68.93/1
451 mm	-	1829 mm	711 mm	787 mm	5.9 m	9.8 sqm	64.0 kg	2.0 cu.

COM	COL	1	2	3	4	5	6	7	8	9	10	11
4212	4342	4819	4920	4978	5094	5195	5238	5310	5411	5498	5599	6177

sku	top material	base finish
	C oak	PA polished aluminum standard, OR
	9 walnut	
	phenolic upcharge \$650	specify powder coat, upcharge \$250
	W phenolic - white	WH satin white
	B phenolic - black	EC ecru
		LA latte
	X none	AL aluminum
		GR graphite
		BZ bronze
		SG sage
		IG iron grey
		RD black red
		BK matte black

Pasadena 6LWS

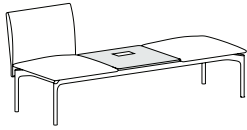

Power - white module
Two-seat armless open end module with center table
Left side facing
Polished aluminum or powder coat base
Upholstered

Center table available in phenolic and all oak and walnut finishes, except for walnut LV8. When specifying light finish the natural characteristics of the wood will be visible and color will vary.

Inside seat depth: 21"

Ganging brackets are sold separately and will ship with the product. See Pasadena accessories page to order bracket.

Power: Surface mount power provides (2) 15 amp receptacles and (2) 2 amp USB-C ports, 20 watt.

When using a combination of fabrics or leathers, specify the application by designating the appropriate letter, shown below, on the purchase order. Yardage shown must be used.

See terms and conditions for contrasting upholstery upcharges.

- A) One fabric or leather for seat
 yardage: 4.5 yds. leather: 73.0 sq. ft.
- B) One fabric or leather for inside back and outside back
 yardage: 2.0 yds. leather: 33.0 sq. ft.

SCS Indoor Advantage™ Gold certified. See terms and conditions for additional environmental information.

*Weight shown represents shipping weight for wood top. Shipping weight for phenolic top is 148 lbs./67.1 kg.

Seat Height	Arm Height	W	D	H	Fabric	Leather	Weight	Cubes/Qty
17¾"	-	72"	28"	31"	6.5 yds	106.0'	*140 lbs.	68.93/1
451 mm	-	1829 mm	711 mm	787 mm	5.9 m	9.8 sqm	64.0 kg	2.0 cu.

COM	COL	1	2	3	4	5	6	7	8	9	10	11
4212	4342	4819	4920	4978	5094	5195	5238	5310	5411	5498	5599	6177

sku	top material	base finish
	C oak	PA polished aluminum standard, OR
	9 walnut	
	phenolic upcharge \$650	specify powder coat, upcharge \$250
	W phenolic - white	WH satin white
	B phenolic - black	EC ecru
		LA latte
	X none	AL aluminum
		GR graphite
		BZ bronze
		SG sage
		IG iron grey
		RD black red
		BK matte black

Pasadena 6STL

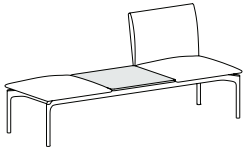

Two-seat armless open end module with center table
Right side facing
Polished aluminum or powder coat base
Upholstered

Center table available in phenolic and all oak and walnut finishes, except for walnut LV8. When specifying light finish the natural characteristics of the wood will be visible and color will vary.

Inside seat depth: 21"

Ganging brackets are sold separately and will ship with the product. See Pasadena accessories page to order brackets.

When using a combination of fabrics or leathers, specify the application by designating the appropriate letter, shown below, on the purchase order. Yardage shown must be used.

See terms and conditions for contrasting upholstery upcharges.

- A) One fabric or leather for seat
 yardage: 4.5 yds. leather: 73.0 sq. ft.
- B) One fabric or leather for inside back and outside back
 yardage: 2.0 yds. leather: 33.0 sq. ft.

SCS Indoor Advantage™ Gold certified. See terms and conditions for additional environmental information.

*Weight shown represents shipping weight for wood top. Shipping weight for phenolic top is 147 lbs./67.0 kg.

Seat Height	Arm Height	W	D	H	Fabric	Leather	Weight	Cubes/Qty
17¾"	-	72"	28"	31"	6.5 yds	106.0'	*139 lbs.	68.93/1
451 mm	-	1829 mm	711 mm	787 mm	5.9 m	9.8 sqm	63.0 kg	2.0 cu.

COM	COL	1	2	3	4	5	6	7	8	9	10	11
3743	3873	4350	4451	4509	4625	4726	4769	4841	4942	5029	5130	5708

sku	top material	base finish
	C oak	PA polished aluminum standard, OR
	9 walnut	
	phenolic upcharge \$650	specify powder coat, upcharge \$250
	W phenolic - white	WH satin white
	B phenolic - black	EC ecru
		LA latte
	X none	AL aluminum
		GR graphite
		BZ bronze
		SG sage
		IG iron grey
		RD black red
		BK matte black

Pasadena 6SBL

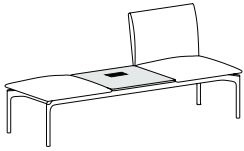

Power - black module
Two-seat armless open end module with center table
Right side facing
Polished aluminum or powder coat base
Upholstered

Center table available in phenolic and all oak and walnut finishes, except for walnut LV8. When specifying light finish the natural characteristics of the wood will be visible and color will vary.

Inside seat depth: 21"

Ganging brackets are sold separately and will ship with the product. See Pasadena accessories page to order bracket.

Power: Surface mount power provides (2) 15 amp receptacles and (2) 2 amp USB-C ports, 20 watt.

When using a combination of fabrics or leathers, specify the application by designating the appropriate letter, shown below, on the purchase order. Yardage shown must be used.

See terms and conditions for contrasting upholstery upcharges.

- A) One fabric or leather for seat
 yardage: 4.5 yds. leather: 73.0 sq. ft.
- B) One fabric or leather for inside back and outside back
 yardage: 2.0 yds. leather: 33.0 sq. ft.

SCS Indoor Advantage™ Gold certified. See terms and conditions for additional environmental information.

*Weight shown represents shipping weight for wood top. Shipping weight for phenolic top is 148 lbs./67.1 kg.

Seat Height	Arm Height	W	D	H	Fabric	Leather	Weight	Cubes/Qty
17¾"	-	72"	28"	31"	6.5 yds	106.0'	*140 lbs.	68.93/1
451 mm	-	1829 mm	711 mm	787 mm	5.9 m	9.8 sqm	64.0 kg	2.0 cu.

COM	COL	1	2	3	4	5	6	7	8	9	10	11
4212	4342	4819	4920	4978	5094	5195	5238	5310	5411	5498	5599	6177

sku	top material	base finish
	C oak	PA polished aluminum standard, OR
	9 walnut	
	phenolic upcharge \$650	specify powder coat, upcharge \$250
	W phenolic - white	WH satin white
	B phenolic - black	EC ecru
		LA latte
	X none	AL aluminum
		GR graphite
		BZ bronze
		SG sage
		IG iron grey
		RD black red
		BK matte black

Pasadena 6SWL

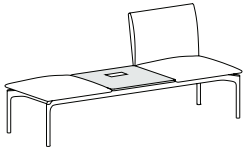

Power - white module
Two-seat armless open end module with center table
Right side facing
Polished aluminum or powder coat base
Upholstered

Center table available in phenolic and all oak and walnut finishes, except for Walnut LV8. When specifying light finish the natural characteristics of the wood will be visible and color will vary.

Inside seat depth: 21"

Ganging brackets are sold separately and will ship with the product. See Pasadena accessories page to order bracket.

Power: Surface mount power provides (2) 15 amp receptacles and (2) 2 amp USB-C ports, 20 watt.

When using a combination of fabrics or leathers, specify the application by designating the appropriate letter, shown below, on the purchase order. Yardage shown must be used.

See terms and conditions for contrasting upholstery upcharges.

- A) One fabric or leather for seat
 yardage: 4.5 yds. leather: 73.0 sq. ft.
- B) One fabric or leather for inside back and outside back
 yardage: 2.0 yds. leather: 33.0 sq. ft.

SCS Indoor Advantage™ Gold certified. See terms and conditions for additional environmental information.

*Weight shown represents shipping weight for wood top. Shipping weight for phenolic top is 148 lbs./67.1 kg.

Seat Height	Arm Height	W	D	H	Fabric	Leather	Weight	Cubes/Qty
17¾"	-	72"	28"	31"	6.5 yds	106.0'	*140 lbs.	68.93/1
451 mm	-	1829 mm	711 mm	787 mm	5.9 m	9.8 sqm	64.0 kg	2.0 cu.

COM	COL	1	2	3	4	5	6	7	8	9	10	11
4212	4342	4819	4920	4978	5094	5195	5238	5310	5411	5498	5599	6177

sku	top material	base finish
	C oak	PA polished aluminum standard, OR
	9 walnut	
	phenolic upcharge \$650	specify powder coat, upcharge \$250
	W phenolic - white	WH satin white
	B phenolic - black	EC ecru
		LA latte
	X none	AL aluminum
		GR graphite
		BZ bronze
		SG sage
		IG iron grey
		RD black red
		BK matte black

Pasadena 6LSS

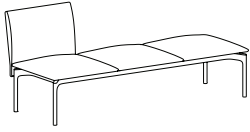

Three-seat armless open end module
Left side facing
Polished aluminum or powder coat base
Upholstered

Inside seat depth: 21"

Ganging brackets are sold separately and will ship with the product. See Pasadena accessories page to order brackets.

When using a combination of fabrics or leathers, specify the application by designating the appropriate letter, shown below, on the purchase order. Yardage shown must be used.

See terms and conditions for contrasting upholstery upcharges.

- A) One fabric or leather for seat
 yardage: 5.75 yds. leather: 94.0 sq. ft.
- B) One fabric or leather for inside back and outside back
 yardage: 2.0 yds. leather: 33.0 sq. ft.

SCS Indoor Advantage™ Gold certified. See terms and conditions for additional environmental information.

Seat Height	Arm Height	W	D	H	Fabric	Leather	Weight	Cubes/Qty
17¾"	-	72"	28"	31"	7.5 yds	126.0'	135 lbs.	68.93/1
451 mm	-	1829 mm	711 mm	787 mm	6.9 m	11.7 sqm	61.2 kg	2.0 cu.

COM	COL	1	2	3	4	5	6	7	8	9	10	11
3365	3515	4065	4182	4249	4382	4499	4549	4632	4749	4849	4965	5632

sku	top material	base finish
	C oak	PA polished aluminum standard, OR
	9 walnut	
	phenolic upcharge \$650	specify powder coat, upcharge \$250
	W phenolic - white	WH satin white
	B phenolic - black	EC ecru
		LA latte
	X none	AL aluminum
		GR graphite
		BZ bronze
		SG sage
		IG iron grey
		RD black red
		BK matte black

Pasadena 6SSL

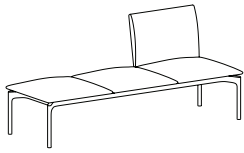

Three-seat armless open module
Right side facing
Polished aluminum or powder coat base
Upholstered

Inside seat depth: 21"

Ganging brackets are sold separately and will ship with the product. See Pasadena accessories page to order brackets.

When using a combination of fabrics or leathers, specify the application by designating the appropriate letter, shown below, on the purchase order. Yardage shown must be used.

See terms and conditions for contrasting upholstery upcharges.

- A) One fabric or leather for seat
 yardage: 5.75 yds. leather: 94.0 sq. ft.
- B) One fabric or leather for inside back and outside back
 yardage: 2.0 yds. leather: 33.0 sq. ft.

SCS Indoor Advantage™ Gold certified. See terms and conditions for additional environmental information.

Seat Height	Arm Height	W	D	H	Fabric	Leather	Weight	Cubes/Qty
17¾"	-	72"	28"	31"	7.5 yds	126.0'	135 lbs.	68.93/1
451 mm	-	1829 mm	711 mm	787 mm	6.9 m	11.7 sqm	61.2 kg	2.0 cu.

COM	COL	1	2	3	4	5	6	7	8	9	10	11
3365	3515	4065	4182	4249	4382	4499	4549	4632	4749	4849	4965	5632

sku	top material	base finish
	C oak	PA polished aluminum standard, OR
	9 walnut	
	phenolic upcharge \$650	specify powder coat, upcharge \$250
	W phenolic - white	WH satin white
	B phenolic - black	EC ecru
		LA latte
	X none	AL aluminum
		GR graphite
		BZ bronze
		SG sage
		IG iron grey
		RD black red
		BK matte black

Pasadena 6ALL

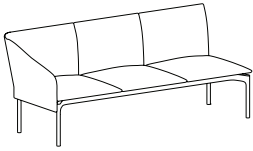

Three-seat module
Left side facing
Polished aluminum or powder coat base
Upholstered

Inside seat depth: 21"

Ganging brackets are sold separately and will ship with the product. See Pasadena accessories page to order brackets.

When using a combination of fabrics or leathers, specify the application by designating the appropriate letter, shown below, on the purchase order. Yardage shown must be used.

See terms and conditions for contrasting upholstery upcharges.

- A) One fabric or leather for seat
yardage: 5.75 yds. leather: 94.0 sq. ft.
- B) One fabric or leather for inside back and outside back
yardage: 4.0 yds. leather: 65.0 sq. ft.

SCS Indoor Advantage™ Gold certified. See terms and conditions for additional environmental information.

Seat Height	Arm Height	W	D	H	Fabric	Leather	Weight	Cubes/Qty
17¾"	27½"	75½"	28"	31"	9.75 yds	158.0'	143 lbs.	68.93/1
451 mm	699 mm	1918 mm	711 mm	787 mm	8.9 m	14.7 sqm	65.0 kg	2.0 cu.

COM	COL	1	2	3	4	5	6	7	8	9	10	11
4874	5069	5784	5936	6023	6196	6348	6413	6521	6673	6803	6954	7821

sku	top material	base finish
	C oak	PA polished aluminum standard, OR
	9 walnut	
	phenolic upcharge \$650	specify powder coat, upcharge \$250
	W phenolic - white	WH satin white
	B phenolic - black	EC ecru
		LA latte
	X none	AL aluminum
		GR graphite
		BZ bronze
		SG sage
		IG iron grey
		RD black red
		BK matte black

Pasadena 6LLA

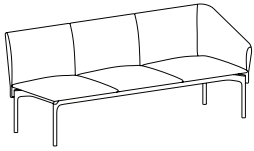

Three-seat module
Right side facing
Polished aluminum or powder coat base
Upholstered

Inside seat depth: 21"

Ganging brackets are sold separately and will ship with the product. See Pasadena accessories page to order brackets.

When using a combination of fabrics or leathers, specify the application by designating the appropriate letter, shown below, on the purchase order. Yardage shown must be used.

See terms and conditions for contrasting upholstery upcharges.

- A) One fabric or leather for seat
 yardage: 5.75 yds. leather: 94.0 sq. ft.
- B) One fabric or leather for inside back and outside back
 yardage: 4.0 yds. leather: 65.0 sq. ft.

SCS Indoor Advantage™ Gold certified. See terms and conditions for additional environmental information.

Seat Height	Arm Height	W	D	H	Fabric	Leather	Weight	Cubes/Qty
17¾"	27½"	75½"	28"	31"	9.75 yds	158.0'	143 lbs.	68.93/1
451 mm	699 mm	1918 mm	711 mm	787 mm	8.9 m	14.7 sqm	65.0 kg	2.0 cu.

COM	COL	1	2	3	4	5	6	7	8	9	10	11
4874	5069	5784	5936	6023	6196	6348	6413	6521	6673	6803	6954	7821

sku	top material	base finish
	C oak 9 walnut phenolic upcharge \$650 W phenolic - white B phenolic - black X none	PA polished aluminum standard, OR specify powder coat, upcharge \$250 WH satin white GR graphite RD black red EC ecru BZ bronze BK matte black LA latte AL aluminum IG iron grey

Pasadena 6ALS

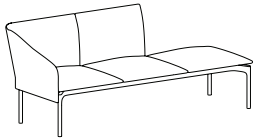

Three-seat open end module
Left side facing
Polished aluminum or powder coat base
Upholstered

Inside seat depth: 21"

Ganging brackets are sold separately and will ship with the product. See Pasadena accessories page to order brackets.

When using a combination of fabrics or leathers, specify the application by designating the appropriate letter, shown below, on the purchase order. Yardage shown must be used.

See terms and conditions for contrasting upholstery upcharges.

- A) One fabric or leather for seat
 yardage: 5.25 yds. leather: 85.0 sq. ft.
- B) One fabric or leather for inside back and outside back
 yardage: 5.5 yds. leather: 90.0 sq. ft.

SCS Indoor Advantage™ Gold certified. See terms and conditions for additional environmental information.

Seat Height	Arm Height	W	D	H	Fabric	Leather	Weight	Cubes/Qty
17¾"	27½"	75½"	28"	31"	10.75 yds	175.0'	152 lbs.	68.93/1
451 mm	699 mm	711 mm	1918 mm	787 mm	9.8 m	16.3 sqm	69.0 kg	2.0 cu.

COM	COL	1	2	3	4	5	6	7	8	9	10	11
4268	4483	5272	5439	5535	5726	5893	5965	6084	6251	6395	6562	7517

sku	top material	base finish
	C oak	PA polished aluminum standard, OR
	9 walnut	
	phenolic upcharge \$650	specify powder coat, upcharge \$250
	W phenolic - white	WH satin white
	B phenolic - black	EC ecru
		LA latte
	X none	AL aluminum
		GR graphite
		BZ bronze
		SG sage
		IG iron grey
		RD black red
		BK matte black

Pasadena 6SLA

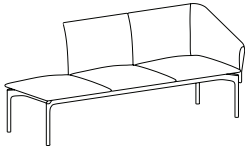

Three-seat open end module
Right side facing
Polished aluminum or powder coat base
Upholstered

Inside seat depth: 21"

Ganging brackets are sold separately and will ship with the product. See Pasadena accessories page to order brackets.

When using a combination of fabrics or leathers, specify the application by designating the appropriate letter, shown below, on the purchase order. Yardage shown must be used.

See terms and conditions for contrasting upholstery upcharges.

- A) One fabric or leather for seat
 yardage: 5.25 yds. leather: 85.0 sq. ft.
- B) One fabric or leather for inside back and outside back
 yardage: 5.5 yds. leather: 90.0 sq. ft.

SCS Indoor Advantage™ Gold certified. See terms and conditions for additional environmental information.

Seat Height	Arm Height	W	D	H	Fabric	Leather	Weight	Cubes/Qty
17¾"	27½"	75½"	28"	31"	10.75 yds	175.0'	152 lbs.	68.93/1
451 mm	699 mm	1918 mm	711 mm	787 mm	9.8 m	16.3 sqm	69.0 kg	2.0 cu.

COM	COL	1	2	3	4	5	6	7	8	9	10	11
4268	4483	5272	5439	5535	5726	5893	5965	6084	6251	6395	6562	7517

sku	top material	base finish
	C oak	PA polished aluminum standard, OR
	9 walnut	
	phenolic upcharge \$650	specify powder coat, upcharge \$250
	W phenolic - white	WH satin white
	B phenolic - black	EC ecru
		LA latte
	X none	AL aluminum
		GR graphite
		BZ bronze
		SG sage
		IG iron grey
		RD black red
		BK matte black

Pasadena 6ALT

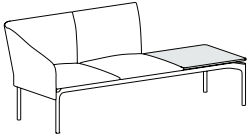

Two-seat module with end table
Left side facing
Polished aluminum or powder coat base
Upholstered

End table available in phenolic and all oak and walnut finishes, except for walnut LV8. the natural characteristics of the wood will be visible and color will vary.

Inside seat depth: 21"

Ganging brackets are sold separately and will ship with the product. See Pasadena accessories page to order brackets.

When using a combination of fabrics or leathers, specify the application by designating the appropriate letter, shown below, on the purchase order. Yardage shown must be used.

See terms and conditions for contrasting upholstery upcharges.

- A) One fabric or leather for seat
 yardage: 6.0 yds. leather: 65.0 sq. ft.
- B) One fabric or leather for inside back and outside back
 yardage: 5.5 yds. leather: 90.0 sq. ft.

SCS Indoor Advantage™ Gold certified. See terms and conditions for additional environmental information.

*Weight shown represents shipping weight for wood top. Shipping weight for phenolic top is 164 lbs./74.3 kg.

Seat Height	Arm Height	W	D	H	Fabric	Leather	Weight	Cubes/Qty
17¾"	27½"	75½"	28"	31"	9.5 yds	154.0'	*156 lbs.	68.93/1
451 mm	699 mm	1918 mm	711 mm	787 mm	8.7 m	14.3 sqm	71.0 kg.	2.0 cu.

COM	COL	1	2	3	4	5	6	7	8	9	10	11
4645	4835	5532	5680	5764	5933	6081	6144	6250	6398	6524	6672	7517

sku	top material	base finish
	C oak	PA polished aluminum standard, OR
	9 walnut	
	phenolic upcharge \$650	specify powder coat, upcharge \$250
	W phenolic - white	WH satin white
	B phenolic - black	EC ecru
	X none	LA latte
		AL aluminum
		GR graphite
		BZ bronze
		SG sage
		IG iron grey
		RD black red
		BK matte black

Pasadena 6ALB

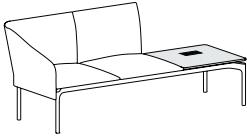

Power - black module
Two-seat module with end table
Left side facing
Polished aluminum or powder coat base
Upholstered

End table available in phenolic and all oak and walnut finishes, except for walnut LV8. When specifying light finish the natural characteristics of the wood will be visible and color will vary.

Inside seat depth: 21"

Ganging brackets are sold separately and will ship with the product. See Pasadena accessories page to order bracket.

Power: Surface mount power provides (2) 15 amp receptacles and (2) 2 amp USB-C ports, 20 watt.

When using a combination of fabrics or leathers, specify the application by designating the appropriate letter, shown below, on the purchase order. Yardage shown must be used.

See terms and conditions for contrasting upholstery upcharges.

- A) One fabric or leather for seat
 yardage: 6.0 yds. leather: 65.0 sq. ft.
- B) One fabric or leather for inside back and outside back
 yardage: 5.5 yds. leather: 90.0 sq. ft.

SCS Indoor Advantage™ Gold certified. See terms and conditions for additional environmental information.

*Weight shown represents shipping weight for wood top. Shipping weight for phenolic top is 165 lbs./75.0 kg.

Seat Height	Arm Height	W	D	H	Fabric	Leather	Weight	Cubes/Qty
17¾"	27½"	75½"	28"	31"	9.5 yds	154.0'	*157 lbs.	68.93/1
451 mm	699 mm	1918 mm	711 mm	787 mm	8.7 m	14.3 sqm	71.2 kg	2.0 cu.

COM	COL	1	2	3	4	5	6	7	8	9	10	11
5114	5304	6001	6149	6233	6402	6550	6613	6719	6867	6993	7141	7986

sku	top material	base finish
	C oak	PA polished aluminum standard, OR
	9 walnut	
	phenolic upcharge \$650	specify powder coat, upcharge \$250
	W phenolic - white	WH satin white
	B phenolic - black	EC ecru
		LA latte
	X none	AL aluminum
		GR graphite
		BZ bronze
		SG sage
		IG iron grey
		RD black red
		BK matte black

Pasadena 6ALW

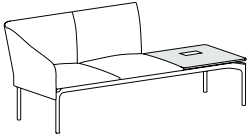

Power - white module
Two-seat module with end table
Left side facing
Polished aluminum or powder coat base
Upholstered

End table available in phenolic and all oak and walnut finishes, except for walnut LV8. When specifying light finish the natural characteristics of the wood will be visible and color will vary.

Inside seat depth: 21"

Ganging brackets are sold separately and will ship with the product. See Pasadena accessories page to order bracket.

Power: Surface mount power provides (2) 15 amp receptacles and (2) 2 amp USB-C ports, 20 watt.

When using a combination of fabrics or leathers, specify the application by designating the appropriate letter, shown below, on the purchase order. Yardage shown must be used.

See terms and conditions for contrasting upholstery upcharges.

- A) One fabric or leather for seat
 yardage: 6.0 yds. leather: 65.0 sq. ft.
- B) One fabric or leather for inside back and outside back
 yardage: 5.5 yds. leather: 90.0 sq. ft.

SCS Indoor Advantage™ Gold certified. See terms and conditions for additional environmental information.

*Weight shown represents shipping weight for wood top. Shipping weight for phenolic top is 165 lbs./75.0 kg.

Seat Height	Arm Height	W	D	H	Fabric	Leather	Weight	Cubes/Qty
17¾"	27½"	75½"	28"	31"	9.5 yds	154.0'	*157 lbs.	68.93/1
451 mm	699 mm	1918 mm	711 mm	787 mm	8.7 m	14.3 sqm	71.2 kg	2.0 cu.

COM	COL	1	2	3	4	5	6	7	8	9	10	11
5114	5304	6001	6149	6233	6402	6550	6613	6719	6867	6993	7141	7986

sku	top material	base finish
	C oak	PA polished aluminum standard, OR
	9 walnut	
	phenolic upcharge \$650	specify powder coat, upcharge \$250
	W phenolic - white	WH satin white
	B phenolic - black	EC ecru
		LA latte
	X none	AL aluminum
		GR graphite
		BZ bronze
		SG sage
		IG iron grey
		RD black red
		BK matte black

Pasadena 6TLA

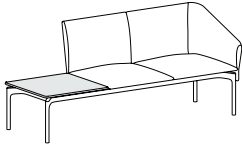

Two-seat module with end table
Right side facing
Polished aluminum or powder coat base
Upholstered

End table available in phenolic and all oak and walnut finishes, except for walnut LV8. When specifying light finish the natural characteristics of the wood will be visible and color will vary.

Inside seat depth: 21"

Ganging brackets are sold separately and will ship with the product. See Pasadena accessories page to order brackets.

When using a combination of fabrics or leathers, specify the application by designating the appropriate letter, shown below, on the purchase order. Yardage shown must be used.

See terms and conditions for contrasting upholstery upcharges.

- A) One fabric or leather for seat
 yardage: 6.0 yds. leather: 65.0 sq. ft.
- B) One fabric or leather for inside back and outside back
 yardage: 5.5 yds. leather: 90.0 sq. ft.

SCS Indoor Advantage™ Gold certified. See terms and conditions for additional environmental information.

*Weight shown represents shipping weight for wood top. Shipping weight for phenolic top is 164 lbs./74.3 kg.

Seat Height	Arm Height	W	D	H	Fabric	Leather	Weight	Cubes/Qty
17¾"	27½"	75½"	28"	31"	9.5 yds	154.0'	*156 lbs.	68.93/1
451 mm	699 mm	1918 mm	711 mm	787 mm	8.7 m	14.3 sqm	71.0 kg	2.0 cu.

COM	COL	1	2	3	4	5	6	7	8	9	10	11
4645	4835	5532	5680	5764	5933	6081	6144	6250	6398	6524	6672	7517

sku	top material	base finish
	C oak	PA polished aluminum standard, OR
	9 walnut	
	phenolic upcharge \$650	specify powder coat, upcharge \$250
	W phenolic - white	WH satin white
	B phenolic - black	EC ecru
	X none	LA latte
		AL aluminum
		GR graphite
		BZ bronze
		SG sage
		IG iron grey
		RD black red
		BK matte black

Pasadena 6BLA

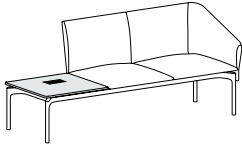

Power - black module
Two-seat module with end table
Right side facing
Polished aluminum or powder coat base
Upholstered

End table available in phenolic and all oak and walnut finishes, except for walnut LV8. When specifying light finish the natural characteristics of the wood will be visible and color will vary.

Inside seat depth: 21"

Ganging brackets are sold separately and will ship with the product. See Pasadena accessories page to order bracket.

Power: Surface mount power provides (2) 15 amp receptacles and (2) 2 amp USB-C ports, 20 watt.

When using a combination of fabrics or leathers, specify the application by designating the appropriate letter, shown below, on the purchase order. Yardage shown must be used.

See terms and conditions for contrasting upholstery upcharges.

- A) One fabric or leather for seat
 yardage: 6.0 yds. leather: 65.0 sq. ft.
- B) One fabric or leather for inside back and outside back
 yardage: 5.5 yds. leather: 90.0 sq. ft.

SCS Indoor Advantage™ Gold certified. See terms and conditions for additional environmental information.

*Weight shown represents shipping weight for wood top. Shipping weight for phenolic top is 165 lbs./75.0 kg.

Seat Height	Arm Height	W	D	H	Fabric	Leather	Weight	Cubes/Qty
17¾"	27½"	75½"	28"	31"	9.5 yds	154.0'	*157 lbs.	68.93/1
451 mm	699 mm	1918 mm	711 mm	787 mm	8.7 m	14.3 sqm	71.2 kg	2.0 cu.

COM	COL	1	2	3	4	5	6	7	8	9	10	11
5114	5304	6001	6149	6233	6402	6550	6613	6719	6867	6993	7141	7986

sku	top material	base finish
	C oak	PA polished aluminum standard, OR
	9 walnut	
	phenolic upcharge \$650	specify powder coat, upcharge \$250
	W phenolic - white	WH satin white
	B phenolic - black	EC ecru
		LA latte
	X none	AL aluminum
		GR graphite
		BZ bronze
		SG sage
		IG iron grey
		RD black red
		BK matte black

Pasadena 6WLA

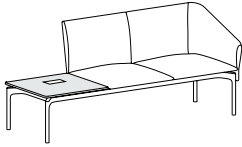

Power - white module
Two-seat module with end table
Right side facing
Polished aluminum or powder coat base
Upholstered

End table available in phenolic and all oak and walnut finishes, except for walnut LV8. When specifying light finish the natural characteristics of the wood will be visible and color will vary.

Ganging brackets are sold separately and will ship with the product. See Pasadena accessories page to order bracket.

Power: Surface mount power provides (2) 15 amp receptacles and (2) 2 amp USB-C ports, 20 watt.

When using a combination of fabrics or leathers, specify the application by designating the appropriate letter, shown below, on the purchase order. Yardage shown must be used.

See terms and conditions for contrasting upholstery upcharges.

- A) One fabric or leather for seat
 yardage: 6.0 yds. leather: 65.0 sq. ft.
- B) One fabric or leather for inside back and outside back
 yardage: 5.5 yds. leather: 90.0 sq. ft.

SCS Indoor Advantage™ Gold certified. See terms and conditions for additional environmental information.

*Weight shown represents shipping weight for wood top. Shipping weight for phenolic top is 165 lbs./75.0 kg.

Seat Height	Arm Height	W	D	H	Fabric	Leather	Weight	Cubes/Qty
17¾"	27½"	75½"	28"	31"	9.5 yds	154.0'	*157 lbs.	68.93'/1
451 mm	699 mm	1918 mm	711 mm	787 mm	8.7 m	14.3 sqm	71.2 kg	2.0 cu.

COM	COL	1	2	3	4	5	6	7	8	9	10	11
5114	5304	6001	6149	6233	6402	6550	6613	6719	6867	6993	7141	7986

sku	top material	base finish
	C oak	PA polished aluminum standard, OR
	9 walnut	
	phenolic upcharge \$650	specify powder coat, upcharge \$250
	W phenolic - white	WH satin white
	B phenolic - black	EC ecru
		LA latte
	X none	AL aluminum
		GR graphite
		BZ bronze
		SG sage
		IG iron grey
		RD black red
		BK matte black

Pasadena 6CXX



**Corner seat
Polished aluminum or powder coat base
Upholstered**

Inside seat depth: 21"

The corner seat is not freestanding and requires two ganging brackets. Ganging brackets are sold separately and will ship with the product. See Pasadena accessories page to order brackets.

When using a combination of fabrics or leathers, specify the application by designating the appropriate letter, shown below, on the purchase order. Yardage shown must be used.

See terms and conditions for contrasting upholstery upcharges.

- A) One fabric or leather for seat
yardage: 1.75 yds. leather: 29.0 sq. ft.
- B) One fabric or leather for inside back and outside back
yardage: 4.0 yds. leather: 65.0 sq. ft.

SCS Indoor Advantage™ Gold certified. See terms and conditions for additional environmental information.

Seat Height	Arm Height	W	D	H	Fabric	Leather	Weight	Cubes/Qty
17¾"	31"	28"	28"	31"	5.75 yds	94.0'	82 lbs	28.8'/1
451 mm	787 mm	711 mm	711 mm	787 mm	5.3 m	8.7 sqm	37.2 kg	.82 cu.

COM	COL	1	2	3	4	5	6	7	8	9	10	11
2170	2285	2707	2797	2848	2950	3039	3078	3142	3231	3308	3397	3908

Pasadena 6HXX



**Corner bench
Polished aluminum or powder coat frame
Upholstered**

The corner bench is not freestanding and requires two ganging brackets. Ganging brackets are sold separately and will ship with the product. See Pasadena accessories page to order bracket.

SCS Indoor Advantage™ Gold and LEVEL® 2 certified. See terms and conditions for additional environmental information.

Seat Height	Arm Height	W	D	H	Fabric	Leather	Weight	Cubes/Qty
17¾"	-	24"	24"	17¾"	2.25	37.0	52 lbs.	16.06'/1
451 mm	-	610 mm	610 mm	451 mm	2.1 m	3.4 sqm	24.0 kg	.45 cu.

COM	COL	1	2	3	4	5	6	7	8	9	10	11
1745	1790	1955	1990	2010	2050	2085	2100	2125	2160	2190	2225	2425

sku	top material	base finish
	C oak	PA polished aluminum standard, OR
	9 walnut	
	phenolic upcharge \$650	specify powder coat, upcharge \$250
	W phenolic - white	WH satin white
	B phenolic - black	EC ecru
	X none	LA latte
		AL aluminum
		GR graphite
		BZ bronze
		SG sage
		IG iron grey
		RD black red
		BK matte black

Pasadena 6KXX



Corner table

Corner table available in phenolic and all oak and walnut finishes, except for walnut LV8. When specifying light finish the natural characteristics of the wood will be visible and color will vary.

The corner table is not freestanding and requires two ganging brackets. Ganging brackets are sold separately and will ship with the product. See Pasadena accessories page to order brackets.

SCS Indoor Advantage™ Gold and LEVEL® 2 certified. See terms and conditions for additional environmental information.

*Weight shown represents shipping weight for wood top. Shipping weight for phenolic top is 65 lbs./29.4 kg.

Seat Height	Arm Height	W	D	H	Fabric	Leather	Weight	Cubes/Qty
17¾"	-	24"	24"	17¾"	-	-	*57 lbs.	16.06/1
451 mm	-	610 mm	610 mm	451 mm	-	-	26.0 kg	

List Price
2085

Pasadena 6KBX



**Power - black module
Corner table**

Corner table available in phenolic and all oak and walnut finishes, except for walnut LV8. When specifying light finish the natural characteristics of the wood will be visible and color will vary.

The corner table is not freestanding and requires two ganging brackets. Ganging brackets are sold separately and will ship with the product. See Pasadena accessories page to order bracket.

Power: Surface mount power provides (2) 15 amp receptacles and (2) 2 amp USB-C ports, 20 watt.

SCS Indoor Advantage™ Gold and LEVEL® 2 certified. See terms and conditions for additional environmental information.

*Weight shown represents shipping weight for wood top. Shipping weight for phenolic top is 66 lbs./30.0 kg.

Seat Height	Arm Height	W	D	H	Fabric	Leather	Weight	Cubes/Qty
17¾"	-	24"	24"	17¾"	-	-	*58 lbs.	16.06/1
451 mm	-	610 mm	610 mm	451 mm	-	-	26.3 kg	.45 cu.

List Price
2554

sku	top material	base finish
	C oak	PA polished aluminum standard, OR
	9 walnut	
	phenolic upcharge \$650	specify powder coat, upcharge \$250
	W phenolic - white	WH satin white
	B phenolic - black	EC ecru
		LA latte
	X none	AL aluminum
		GR graphite
		BZ bronze
		SG sage
		IG iron grey
		RD black red
		BK matte black

Pasadena 6KWX



**Power - white module
Corner table**

Corner table available in phenolic and all oak and walnut finishes, except for walnut LV8. When specifying light finish the natural characteristics of the wood will be visible and color will vary.

The corner table is not freestanding and requires two ganging brackets. Ganging brackets are sold separately and will ship with the product. See Pasadena accessories page to order bracket.

Power: Surface mount power provides (2) 15 amp receptacles and (2) 2 amp USB-C ports, 20 watt.

SCS Indoor Advantage™ Gold and LEVEL® 2 certified. See terms and conditions for additional environmental information.

*Weight shown represents shipping weight for wood top. Shipping weight for phenolic top is 66 lbs./30.0 kg.

Seat Height	Arm Height	W	D	H	Fabric	Leather	Weight	Cubes/Qty
17¾"	-	24"	24"	17¾"	-	-	*58 lbs.	16.06/1
451 mm	-	610 mm	610 mm	451 mm	-	-	26.3 kg.	.45 cu.

List Price
2554

sku	top material	base finish
	C oak	PA polished aluminum standard, OR
	9 walnut	
	phenolic upcharge \$650	specify powder coat, upcharge \$250
	W phenolic - white	WH satin white
	B phenolic - black	EC ecru
	X none	LA latte
		AL aluminum
		GR graphite
		BZ bronze
		SG sage
		IG iron grey
		RD black red
		BK matte black

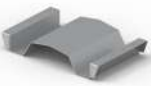
	description	sku	w	d	h	price
	<p>ganging bracket - grey Order one ganging bracket per point of connection of modular units. Ganging brackets are sold separately and will ship with product.</p>	6K111	14½	9	2½	\$ 108

sku

6	K	1	1	1
---	---	---	---	---

Valentina Seating System Specification Guide

Standard Features



Valentina is a modular seating system comprised of 6 unique modules which can be used interchangeably to create an unlimited number of configurations. All modules can also be used as freestanding units.

Valentina features new contrasting fabric options and comes standard with welt and a saddle stitch detail on the seat, back and arm.

Configurations are connected by a ganging bracket. Ganging brackets are included with each module. 1½" diameter non-marring adjustable glide.

When ordering configurations, please provide the total COM yardage from the same dye lot in a continuous roll(s). All COM/COL fabrics must be preapproved by Bernhardt Design prior to application.

Valentina is SCS Indoor Advantage™ Gold and LEVEL® 2 certified. See terms and conditions for additional finish and environmental information.

Please visit Bernhardtdesign.com for a complete library of 2D, 3D, and Revit models. You may also contact your local sales representative or the Bernhardt Design Corporate office for specification assistance.

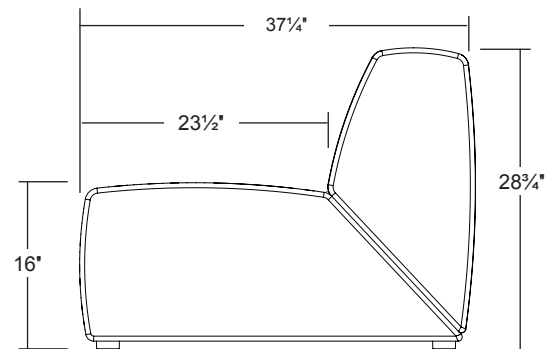

Side view of sku 5650

1½" Diameter Non-Marring Adjustable Nylon Glides

Valentina Contrasting Fabric Options

Valentina modular seating offers three contrasting fabric options.

- A. Inside seat and back, top and side panels of the arms.
- B. Seat and back side panels, front and back panels of the arms.
- C. Welt

*All COM/COL fabrics must be preapproved by Bernhardt Design prior to application. When ordering multi-item configurations, provide the total COM yardage from the same dye lot in a continuous roll(s). See terms and conditions for instructions for tagging COM.

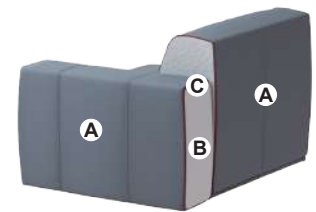
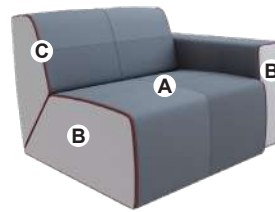

Valentina Seating System Sample Configurations

1

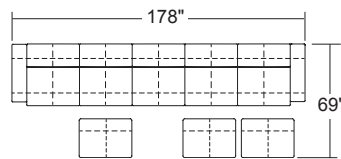
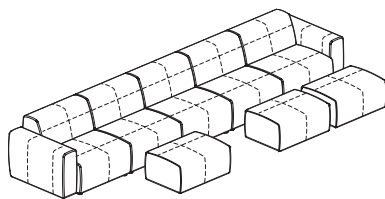

SKU	Description
5651	Single Seat. Left Arm Facing Module
5650	(3) Single Seat Modules. Armless
5652	Single Seat. Right Arm Facing Module
5655	(3) Ottomans

2

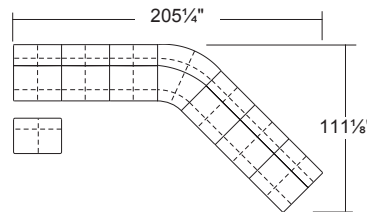
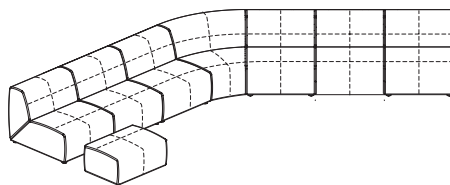

5650	(3) Single Seat Modules. Armless
5654	45° Connector
5650	(3) Single Seat Modules. Armless
5655	Ottoman

3

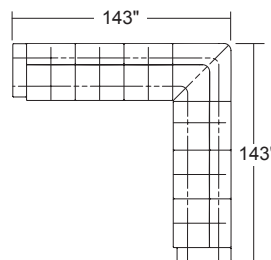
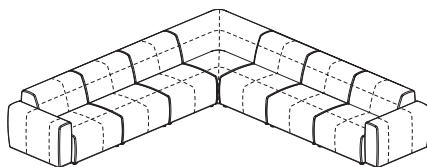

5651	Single Seat. Left Arm Facing Module
5650	(2) Single Seat Modules. Armless
5653	90° Corner Connector
5650	(2) Single Seat Modules. Armless
5652	Single Seat. Right Arm Facing Module

4

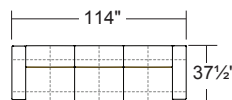
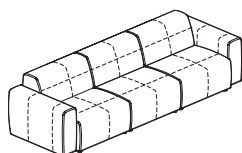

5651	Single Seat. Left Arm Facing Module
5650	Single Seat Module. Armless
5652	Single Seat. Right Arm Facing Module

valentina 5650

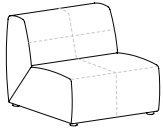

**Single seat module
Armless
Fully upholstered**

Saddle stitch detail on seat and back; standard with welt
All necessary ganging brackets are included and pre-installed

When using a combination of fabrics or leathers, specify the application by designating the appropriate letter, shown below, on the purchase order. Yardage shown must be used.

See terms and conditions for contrasting upholstery upcharges.

- A) One fabric or leather for inside seat and back
yardage: 3.25 yds. leather: 53.0 sq. ft.
- B) One fabric or leather for seat and back sides panels
yardage: 2.25 yds. leather: 37.0 sq. ft.
- C) One fabric or leather for welt
yardage: 2.0 yd. leather: 33.0 sq. ft.

SCS Indoor Advantage™ Gold and LEVEL® 2 certified. See terms and conditions for additional environmental information.

Seat Height	Arm Height	W	D	H	Fabric	Leather	Weight	Cubes/Qty
16"	-	32¾"	37¼"	28¾"	5.25 yds.	85.0'	91 lbs.	32.10/1
406 mm	-	832 mm	947 mm	731 mm	4.8 m	7.9 sqm	41.27 kg.	.91 cu.

COM	COL	1	2	3	4	5	6	7	8	9	10	11
1947	2052	2437	2519	2566	2659	2741	2776	2834	2916	2986	3067	3534

valentina 5651

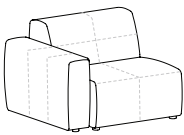

**Single seat
Left arm facing module
Fully upholstered**

Saddle stitch detail on seat and back; standard with welt
All necessary ganging brackets are included and pre-installed

When using a combination of fabrics or leathers, specify the application by designating the appropriate letter, shown below, on the purchase order. Yardage shown must be used.

See terms and conditions for contrasting upholstery upcharges.

- A) One fabric or leather for inside seat and back, top and side panels of the arm
yardage: 4.25 yds. leather: 70.0 sq. ft.
- B) One fabric or leather for seat and back side panels, front and back panels of the arm
yardage: 2.25 yds. leather: 37.0 sq. ft.
- C) One fabric or leather for welt
yardage: 2.0 yd. leather: 33.0 sq. ft.

SCS Indoor Advantage™ Gold and LEVEL® 2 certified. See terms and conditions for additional environmental information.

Seat Height	Arm Height	W	D	H	Fabric	Leather	Weight	Cubes/Qty
16"	23"	40 7/8"	37 ¼"	28¾"	7.0 yds.	114.0'	129 lbs.	45.85/1
406 mm	585 mm	1041 mm	947 mm	731 mm	6.4 m	10.6 sqm	58.51 kg.	1.30 cu.

COM	COL	1	2	3	4	5	6	7	8	9	10	11
2488	2628	3142	3251	3313	3437	3546	3593	3671	3780	3873	3982	4604

valentina 5652

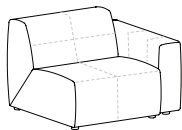

**Single seat
Right arm facing module
Fully upholstered**

Saddle stitch detail on seat and back; standard with welt
All necessary ganging brackets are included and pre-installed

When using a combination of fabrics or leathers, specify the application by designating the appropriate letter, shown below, on the purchase order. Yardage shown must be used.

See terms and conditions for contrasting upholstery upcharges.

- A) One fabric or leather for inside seat and back, top and side panels of the arm
yardage: 4.25 yds. leather: 70.0 sq. ft.
- B) One fabric or leather for seat and back side panels, front and back panels of the arm
yardage: 2.25 yds. leather: 37.0 sq. ft.
- C) One fabric or leather for welt
yardage: 2.0 yd. leather: 33.0 sq. ft.

SCS Indoor Advantage™ Gold and LEVEL® 2 certified. See terms and conditions for additional environmental information.

Seat Height	Arm Height	W	D	H	Fabric	Leather	Weight	Cubes/Qty
16"	23"	40 7/8"	37 1/4"	28 3/4"	7.0 yds.	114.0'	129 lbs.	45.85'/1
406 mm	585 mm	1041 mm	947 mm	731 mm	6.4 m	10.6 sqm	58.51 kg.	1.30 cu.

COM	COL	1	2	3	4	5	6	7	8	9	10	11
2488	2628	3142	3251	3313	3437	3546	3593	3671	3780	3873	3982	4604

valentina 5653

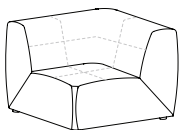

**90° Connector
Fully upholstered**

Saddle stitch detail on seat and back; standard with welt
All necessary ganging brackets are included and pre-installed

When using a combination of fabrics or leathers, specify the application by designating the appropriate letter, shown below, on the purchase order. Yardage shown must be used.

See terms and conditions for contrasting upholstery upcharges.

- A) One fabric or leather for inside seat and back
yardage: 5.25 yds. leather: 85.0 sq. ft.
- B) One fabric or leather for seat and back side panels
yardage: 2.25 yds. leather: 37.0 sq. ft.
- C) One fabric or leather for welt
yardage: 2.0 yd. leather: 33.0 sq. ft.

SCS Indoor Advantage™ Gold and LEVEL® 2 certified. See terms and conditions for additional environmental information.

Seat Height	Arm Height	W	D	H	Fabric	Leather	Weight	Cubes/Qty
16"	-	38 1/2"	38 1/2"	28 3/4"	6.75 yds.	110.0'	128 lbs.	45.85'/1
406 mm	-	978 mm	978 mm	731 mm	6.2 m	10.2 sqm	58.06 kg.	1.30 cu.

COM	COL	1	2	3	4	5	6	7	8	9	10	11
2813	2948	3443	3548	3608	3728	3833	3878	3953	4058	4148	4253	4853

valentina 5654

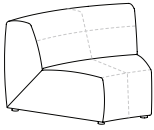

**45° Connector
Fully upholstered**

Saddle stitch detail on seat and back; standard with welt
All necessary ganging brackets are included and pre-installed

When using a combination of fabrics or leathers, specify the application by designating the appropriate letter, shown below, on the purchase order. Yardage shown must be used.

See terms and conditions for contrasting upholstery upcharges.

- A) One fabric or leather for inside seat and back
yardage: 4.0 yds. leather: 65.0 sq. ft.
- B) One fabric or leather for seat and back side panels
yardage: 1.75 yds. leather: 28.0 sq. ft.
- C) One fabric or leather for welt
yardage: 1.0 yd. leather: 16.0 sq. ft.

SCS Indoor Advantage™ Gold and LEVEL® 2 certified. See terms and conditions for additional environmental information.

Seat Height	Arm Height	W	D	H	Fabric	Leather	Weight	Cubes/Qty
16"	-	45½"	40"	28¾"	6.75 yds.	109.0'	128 lbs.	32.10'/1
406 mm	-	1156 mm	1016 mm	731 mm	6.2 m	10.2 sqm	58.06 kg.	.91 cu.

COM	COL	1	2	3	4	5	6	7	8	9	10	11
2488	2623	3118	3223	3283	3403	3508	3553	3628	3733	3823	3928	4528

valentina 5655

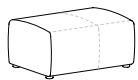

**Ottoman
Fully upholstered**

Saddle stitch detail on seat and back; standard with welt

When using a combination of fabrics or leathers, specify the application by designating the appropriate letter, shown below, on the purchase order. Yardage shown must be used.

See terms and conditions for contrasting upholstery upcharges.

- A) One fabric or leather for top seat panel and upper body
yardage: 2.25 yds. leather: 37.0 sq. ft.
- B) One fabric or leather for lower body
yardage: 1.5 yds. leather: 25.0 sq. ft.
- C) One fabric or leather for welt
yardage: 1.0 yd. leather: 16.0 sq. ft.

SCS Indoor Advantage™ Gold and LEVEL® 2 certified. See terms and conditions for additional environmental information.

Seat Height	Arm Height	W	D	H	Fabric	Leather	Weight	Cubes/Qty
-	-	32"	23½"	15¼"	4.8 yds.	78.0'	45 lbs.	15.31'/1
-	-	813 mm	597 mm	388 mm	4.4 m	7.3 sqm	20.41 kg.	.44 cu.

COM	COL	1	2	3	4	5	6	7	8	9	10	11
1082	1176	1521	1594	1636	1720	1793	1824	1876	1949	2012	2085	2503

PA01 decorative pillow

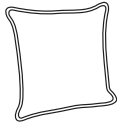

**Knife edge
Blown fiber filled with zipper closure**

All COM/COL fabrics must be preapproved by Bernhardt Design prior to application.

Seat Height	Arm Height	W	D	H	Fabric	Leather	Weight	Cubes/Qty
-	-	15"	4"	15"	.75 yds.	12.0'	8 lbs.	.89/1
-	-	381 mm	102 mm	381 mm	.69 m	1.1 sqm	3.6 kg	.03 cu.

COM	1	2	3	4	5	6	7	8	9	10	11
306	376	388	395	408	420	425	433	445	455	466	533

PA02 decorative pillow

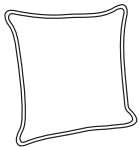

**Knife edge
Blown fiber filled with zipper closure**

All COM/COL fabrics must be preapproved by Bernhardt Design prior to application.

Seat Height	Arm Height	W	D	H	Fabric	Leather	Weight	Cubes/Qty
-	-	17"	4"	17"	.75 yds.	12.0'	8 lbs.	.89/1
-	-	432 mm	102 mm		.69 m	1.1 sqm	3.6 kg	.03 cu.

COM	1	2	3	4	5	6	7	8	9	10	11
306	376	388	395	408	420	425	433	445	455	466	533

PA03 decorative pillow

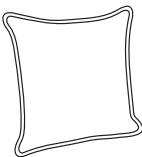

**Knife edge
Blown fiber filled with zipper closure**

All COM/COL fabrics must be preapproved by Bernhardt Design prior to application.

Seat Height	Arm Height	W	D	H	Fabric	Leather	Weight	Cubes/Qty
-	-	19"	4"	19"	.75 yds.	12.0'	8 lbs.	.89/1
-	-	483 mm	102 mm	483 mm	.69 m	1.1 sqm	3.6 kg	.03 cu.

COM	1	2	3	4	5	6	7	8	9	10	11
306	376	388	395	408	420	425	433	445	455	466	533

PA04 decorative pillow

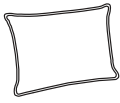

**Knife edge
Blown fiber filled with zipper closure**

All COM/COL fabrics must be preapproved by Bernhardt Design prior to application.

Seat Height	Arm Height	W	D	H	Fabric	Leather	Weight	Cubes/Qty
-	-	22"	6"	15"	1.0 yds.	15.0'	10 lbs.	.92'/1
-	-	559 mm	152 mm	381 mm	.92 m	1.4 sqm	4.5 kg	.03 cu.

COM	1	2	3	4	5	6	7	8	9	10	11
324	418	433	442	460	476	482	493	509	522	538	627

PA05 decorative pillow

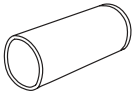

**Bolster round pillow
HR-15 foam with welt and zipper closure**

All COM/COL fabrics must be preapproved by Bernhardt Design prior to application.

Seat Height	Arm Height	W	D	H	Fabric	Leather	Weight	Cubes/Qty
-	-	18 1/4"	5 1/2"	5 1/2"	.75 yds.	12.0'	9 lbs.	.93'/1
-	-	464 mm	140 mm	140 mm	.69 m	1.1 sqm	3.6 kg	.03 cu.

COM	1	2	3	4	5	6	7	8	9	10	11
370	440	452	459	472	484	489	497	509	519	530	597

PA06 decorative pillow

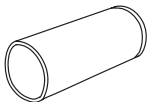

**Bolster round pillow
HR-15 foam with welt and zipper closure**

All COM/COL fabrics must be preapproved by Bernhardt Design prior to application.

Seat Height	Arm Height	W	D	H	Fabric	Leather	Weight	Cubes/Qty
-	-	19 3/4"	5 1/2"	5 1/2"	.75 yds.	12.0'	9 lbs.	.93'/1
-	-	502 mm	140 mm	140 mm	.69 m	1.1 sqm	3.6 kg	.03 cu.

COM	1	2	3	4	5	6	7	8	9	10	11
370	440	452	459	472	484	489	497	509	519	530	597

PA07 decorative pillow

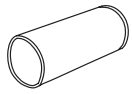

**Bolster round pillow
HR-15 Foam with welt and zipper closure**

All COM/COL fabrics must be preapproved by Bernhardt Design prior to application.

Seat Height	Arm Height	W	D	H	Fabric	Leather	Weight	Cubes/Qty
-	-	21"	6"	6"	1.0 yds.	15.0'	9 lbs.	.93/1
-	-	533 mm	152 mm	152 mm	.92 m	1.4 sqm	3.6 kg	3.6 kg

COM	1	2	3	4	5	6	7	8	9	10	11
370	464	479	488	506	522	528	539	555	568	584	673

PB01 decorative pillow

**1/2" Panel border
Down-filled with zipper closure**

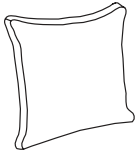

All COM/COL fabrics must be preapproved by Bernhardt Design prior to application.

Seat Height	Arm Height	W	D	H	Fabric	Leather	Weight	Cubes/Qty
-	-	16½"	4"	16½"	1.0 yds.	18.0'	8 lbs.	.89/1
-	-	420 mm	102 mm	420 mm	.92 m	1.7 sqm	3.6 kg	.02 cu.

COM	1	2	3	4	5	6	7	8	9	10	11
306	400	415	424	442	458	464	475	491	504	520	609

PB02 decorative pillow

**1/2" Panel border.
Down-filled with zipper closure.**

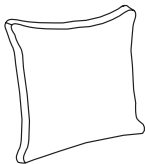

All COM/COL fabrics must be preapproved by Bernhardt Design prior to application.

Seat Height	Arm Height	W	D	H	Fabric	Leather	Weight	Cubes/Qty
-	-	18½"	4"	18½"	1.0 yds.	20.0'	8 lbs.	.89/1
-	-	470 mm	102 mm	470 mm	.92 m	1.9 sqm	3.6 kg	.02 cu.

COM	1	2	3	4	5	6	7	8	9	10	11
306	400	415	424	442	458	464	475	491	504	520	609

stacking cart 1105



Mobile cart

Mobile cart for Bernhardt stacking chairs
Silver powder coated steel
4" threaded casters

SCS Indoor Advantage™ Gold certified.

Seat Height	Arm Height	W	D	H	Fabric	Leather	Weight	Cubes/Qty
-	-	27½"	42"	39½"	-	-	35 lbs	25.91'/1
-	-	699 mm	1067 mm	1003 mm	-	-	15.9 kg	.73 cu

List Price

1864

stacking cart 1700-00

PLANK



**Stacking cart
Black metal frame**

Stacking cart compatible with Monza 1209-40, Remo 1416-20 and Remo 1415-20

Seat Height	Arm Height	W	D	H	Fabric	Leather	Weight	Cubes/Qty
-	-	17¼"	31½"	39¾"	-	-	22 lbs.	11.75'/1
-	-	451 mm	801 mm	1010 mm	-	-	10 kg	.31 cu.

List Price

1061

stacking cart 1720-00

PLANK



**Stacking cart
Black metal frame**

Stacking cart compatible with Miura 8200-00

Seat Height	Arm Height	W	D	H	Fabric	Leather	Weight	Cubes/Qty
-	-	13¾"	25⅝"	35⅞"	-	-	19 lbs.	7.75'/1
-	-	350 mm	651	912 mm	-	-	8.6 kg	.22 cu.

List Price

1061

stacking cart 1730-00

PLANK



**Stacking cart
Black metal frame**

Stacking cart compatible with Myto 1207-20.

Seat Height	Arm Height	W	D	H	Fabric	Leather	Weight	Cubes/Qty
-	-	17½"	31½"	39¾"	-	-	22 lbs.	11.75'/1
-	-	451 mm	801 mm	1010 mm	-	-	10 kg	.31 cu.

List Price
1061

stacking cart 1740-00

PLANK



**Stacking cart
Black metal frame**

Stacking cart compatible with Miura 9553, Miura 9590, Miura 9591, Miura 9592 and Miura 9580

Seat Height	Arm Height	W	D	H	Fabric	Leather	Weight	Cubes/Qty
-	-	27½"	42⅞"	39¾"	-	-	56 lbs.	42.38'/1
-	-	699 mm	1090 mm	1001 mm	-	-	25.4 kg	1.20 cu.

List Price
1472

stacking cart 1750-00

PLANK



**Stacking cart
Black metal frame**

Stacking cart compatible with Remo 1417-20 and Remo 1418-20

Seat Height	Arm Height	W	D	H	Fabric	Leather	Weight	Cubes/Qty
-	-	23⅞"	29⅞"	32¾"	-	-	27 lbs.	42.38'/1
-	-	601 mm	759 mm	826 mm	-	-	12.3 kg	1.20 cu.

List Price
1166

stacking cart 1770-00

PLANK

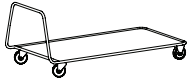

Stacking cart
Black metal frame

Stacking cart compatible with Miura 9587-01, 9587-71 and Miura 9586-01, 9586-71

Seat Height	Arm Height	W	D	H	Fabric	Leather	Weight	Cubes/Qty
-	-	41½"	59"	33½"	-	-	159 lbs.	85.5/1
-	-	1051 mm	1499 mm	851 mm	-	-	72.1 kg	2.42 cu.

List Price

1677

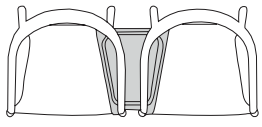
description	sku	w	d	h	price
 <p>linking device Vacuum-formed polystyrene</p> <p>Linking device compatible with all indoor and outdoor Plank Monza arm chairs.</p> 	1209-90	14½	9½	3½	\$ 260

Veneer Selections

A three character sku identifies each species as well as the standard finish offered. Individual components are priced with standard finish. Special finishes on veneers made to customer specifications are subject to factory approval and a 10% net upcharge with a \$500 net minimum.

Transparent stains and sealers are applied in multiple steps to enhance the beauty of the natural wood. A durable, baked-on, top-coat of conversion

varnish or UV topcoat is applied to protect the product. It is recommended that felt, cork or fabric backed desk pads and accessories are used on worksurfaces to minimize wear.

When specifying light finishes the natural characteristics of the wood will be visible and color will vary. Paint finishes are available as custom orders. See terms and conditions for additional finish information.

PNT Paint

Standard Finish
100
101

ASH Ash
Rift Cut

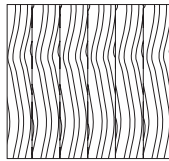

Standard Finish
871 870 839
837 860 861
865 836 866
872 805 845

ASH Select Finishes
M73 M72 M75
M74 M76 M77
M71

MPL Maple
Flat Cut

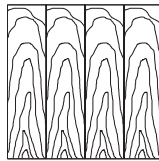

Standard Finish
871 860 861
837 836 823
865 805 866
872 839 845
870

OAK Oak
Rift Cut

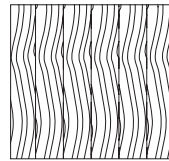

Standard Finish
871 870 839
837 860 861
865 836 866
872 805 845

OAK Select Finishes
M73 M71 M75
M74 M76 M77
M71

WLT Walnut
Flat Cut

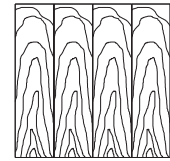

Standard Finish
872 861
870 823
860 866
839

PNT Paint

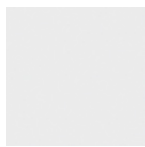

100

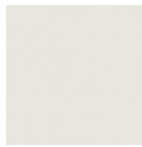

101

100 and 101 paint finishes are only available on ash, maple and oak.

ASH Ash



871

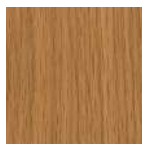

837



865



872

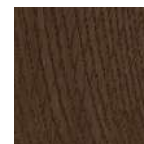

870



860



836



805



839



861



866



845

ASH Select Finishes



M73 Whitewash

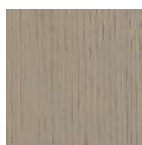

M74 Fawn



M71 Blonde

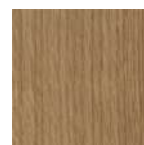

M72 Toast

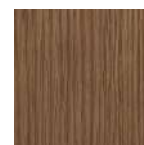

M76 Caramel



M75 Smoke



M77 Coffee

Veneer Selections

MPL Maple



OAK Oak



OAK Select Finishes

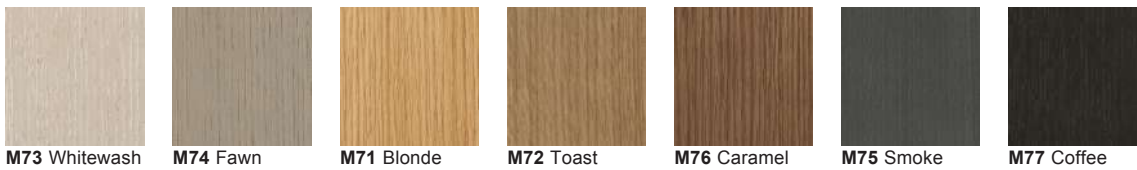

WLT Walnut

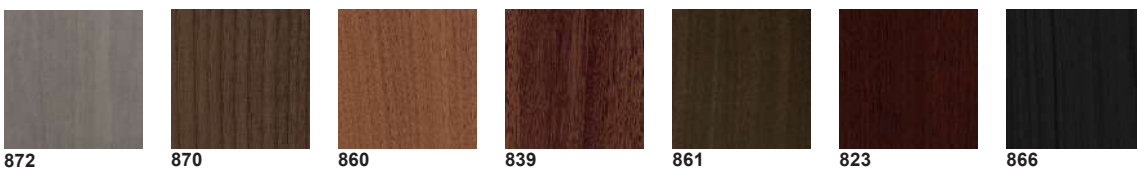

Powder Coat Finishes

A two character sku identifies each powder coat finish offered. Individual skus are priced with standard metal finish. Non-standard finishes may incur an additional charge. The powder coat option is available on skus where noted as an option in the material specification code.

Powder Coat Finishes - Upcharges apply.

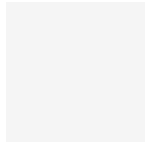

WH Satin White

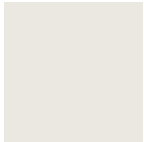

EC Ecru

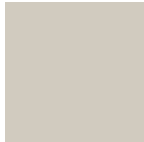

LA Latte



GR Graphite



BZ Bronze



IG Iron Grey



RD Black Red



BK Matte Black

Optional Powder Coat Colors - RAL

- Lead Time - Three weeks additional lead-time after color approval
- Net Up-charge - \$1000 for colors shown in Bernhardt Design RAL Powder Coat Selector
- Minimum Order Quantity - None
- Approval Sample Cost - None
- Combining Products - One up-charge is applicable for multiple products on a single purchase order when they are in the same color

Veneer + Metal Selections - PLANK

A two or three character sku identifies each species as well as the standard finish offered. Individual components are priced with standard finish. Special finishes are subject to approval, minimums, and a \$500 net upcharge.

When specifying light finishes the natural characteristics of the wood will be visible and color will vary. Custom finishes are available as custom orders. See terms and conditions for additional finish information.

Optional Veneers Colors - RAL

- Lead Time - Four weeks additional lead-time after color approval
- Net Up-charge - \$500 for veneer colors
- Minimum Order Quantity - 20

Veneer Finishes

ASH Ash



AWH White



AC Chalk



AN Natural



AY Yellow



ABL Blue

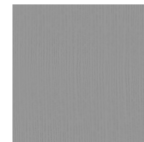

AG Grey



AW Walnut



AB Black

OAK Oak



Natural

WLT Walnut



Canaletto Natural

IR Iroko



Natural

Metal Finishes



CH
Chrome



ALS
Satin Aluminum



ALP
Polished Aluminum

Powder Coat Finishes

A numerical sku identifies each powder coat finish offered. Individual skus are priced with standard metal finish. Non-standard finishes may incur an additional charge. The powder coat option is available on skus where noted as an option in the material specification code.

Optional Powder Coat Colors - PLANK RAL

- Lead Time - Four weeks additional lead-time after color approval
- Net Up-charge - \$500 for colors shown in Plank RAL Powder Coat Selector
- Minimum Order Quantity - 20

Powder Coat Finishes - PLANK



Polyethylene Finishes - PLANK



Polypropylene Finishes - PLANK



grade 1

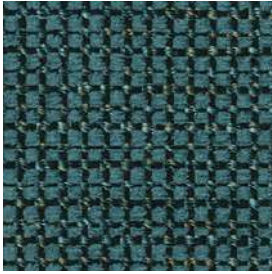

align 3520

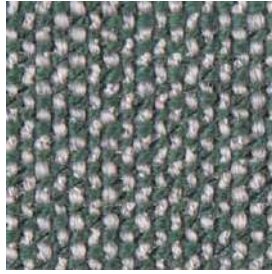

classic fit 3556

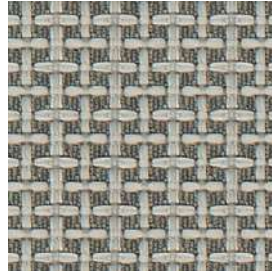

crosshatch 3547



delight 3651



emerge 3838

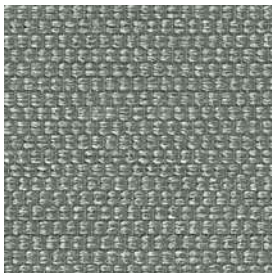

kavir 3518



pocket square 3555

grade 2



bomber jacket 3839



cherish 3560

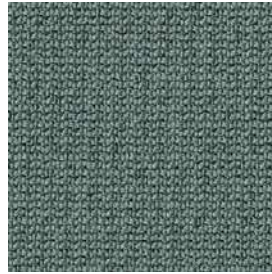

daybreak 3530



diffuse 3528



sketch 3548



solo 3505

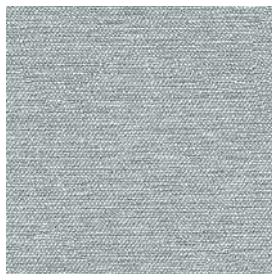

still 3544

grade 3

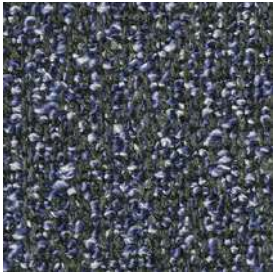

loop 3519

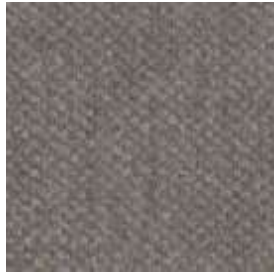

soft spun 3563



vella 3554

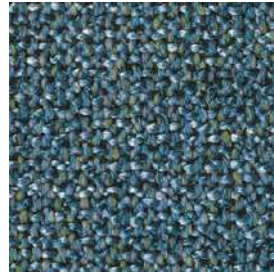

vista 3525

grade 4



canvas 3837



element 3495

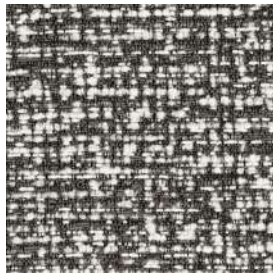

pix 3509



smooth 3552

grade 5

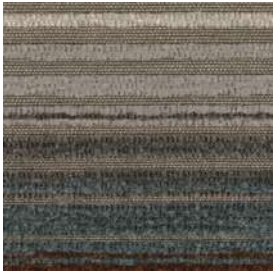

cadence 3506



chunky 3551

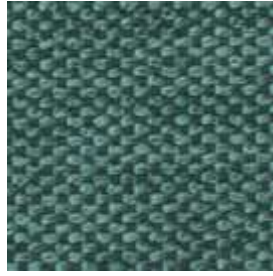

pearl 3490



plush 3550

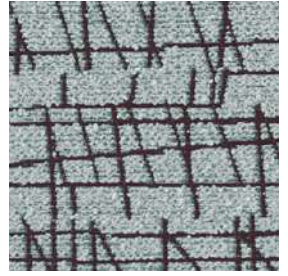

random 3524



soft 3553

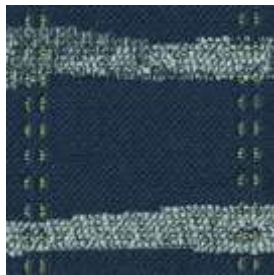

stitch 3426

grade 6



allude 3812

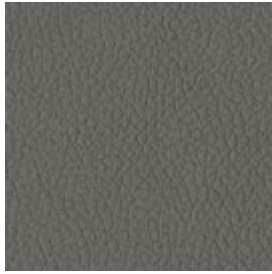

brisa 3802



cielo 3536



hero 3463



image 3799

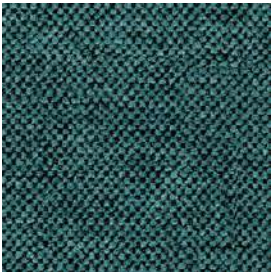

sereno 3538



vivid 3523

grade 7



bangkok 3565

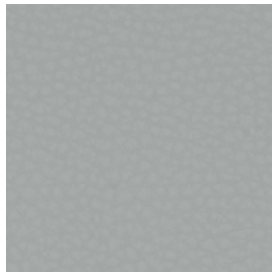

blended 3840



hendese 3515

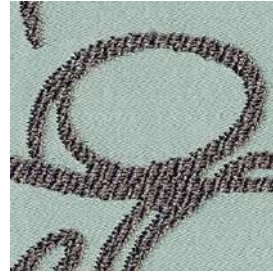

sella 3542

grade 8

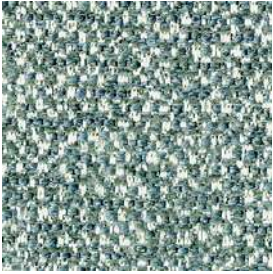

bella 3539



fresca 3540



istanbul 3566



midnight 3534



nightfall 3533



perfect plaid 3562

grade 9



mirage 3529



tailored 3557

grade 10

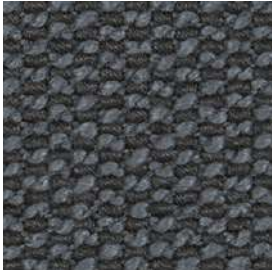

adore 3558



aspire 3559

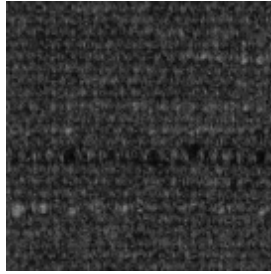

crafted wool 3564



kumasi 3568



patina 3537



roma 3567

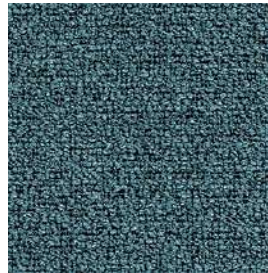

snug 3546

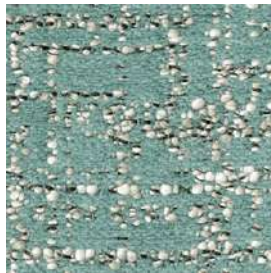

twilight 3532

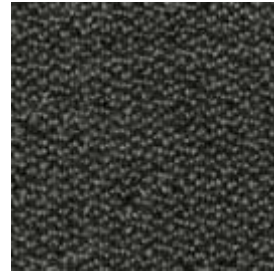

venture 3484

grade 11

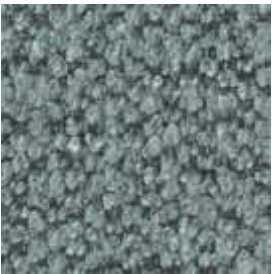

cameo 3465



imprint 3508

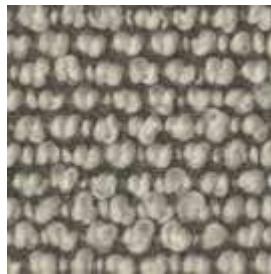

muse 3454

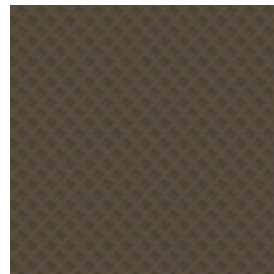

océane 3491



valencia 3295

coated fabric

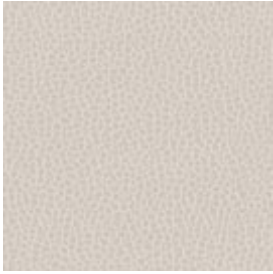

allude 3812



blended 3840



bomber jacket 3839

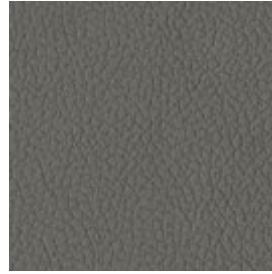

brisa 3802



canvas 3837

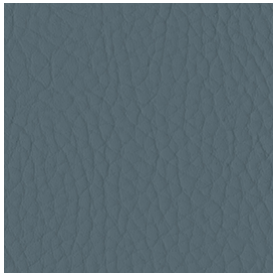

emerge 3838

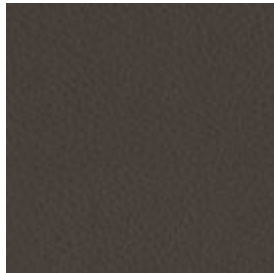

image 3799

leather - available for COL purchase



elan 3111



essential 3113



london 3114

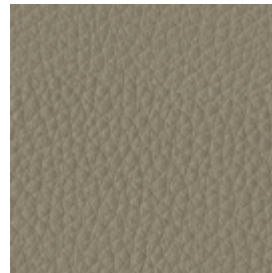

rogue 3110

Prices and Specifications

Prices and specifications are subject to change without notice. All prices quoted will be FOB our factories. If applicable, sales tax will be based on ship-to destination.

Bernhardt Design reserves the right to make changes in dimensions, design and/or construction, price lists, or product literature without prior notice.

All measurements and weights are approximate and subject to change without notice.

Order Entry

All orders are subject to final acceptance by Bernhardt Design in Lenoir, NC. Receipt of our acknowledgment indicates acceptance of your order subject to the terms set forth on the acknowledgment.

Bernhardt Design attempts to clarify all purchase orders. However, in the event the price list number and description on the purchase order differ, the price list number will prevail.

Changes / Cancellation

All orders in production are considered firm orders and are not subject to changes or cancellation.

Shipping

Bernhardt Design will ship in accordance with customer instructions whenever possible. For convenience, Bernhardt Design offers a guaranteed freight program (GFP). Bernhardt Design will exercise our best judgment in selecting a carrier under our GFP. When selecting a carrier, Bernhardt Design will make our best effort to meet requested delivery dates.

Transportation lead-times and delays including equipment problems, weather, general traffic, traffic accidents, customer warehouse space, labor disputes, customer changes, etc., that occur on a carrier will not be the responsibility of Bernhardt Design. Furthermore, Bernhardt Design will not be responsible for additional costs incurred due to aforementioned delays.

For customers who decline our GFP, Bernhardt Design will stage orders for pick up at 1% of the list price, or \$75 minimum.

Customer orders in production will be shipped as scheduled and will not be held. Bernhardt Design reserves the right to make partial shipments on any order, unless notified otherwise by the customer.

High quality cartoning meeting trucking and railroad specifications is standard at no extra charge. Some items may be blanket wrapped for shipment.

Freight Damage and Claims

Bernhardt Design is not liable for any damages to products that occur during transit or storage. The carrier assumes all responsibility upon acceptance of product. It is the customer's responsibility to inspect products upon receipt and file any claims with the carrier. No product should be refused.

If products are received damaged, a written exception should be made on the bill of lading and an immediate inspection be requested of the carrier.

Concealed damage must be reported to the carrier within 10 business days from date of delivery. Failure to make claims shall constitute acceptance of the products and waiver any claims of defects, errors or shortages.

In the event delivery is made on a Bernhardt Design truck, the products should be carefully inspected for transit damage. If contents are damaged, the driver should be notified to call his dispatcher for immediate disposition.

Concealed damage must be reported within 10 business days from date of delivery and product/packaging held for inspection by a Bernhardt Design representative. Replacements for product damaged in shipment or storage will be manufactured upon receipt of a purchase order.

Returns

No merchandise may be returned to Bernhardt Design without written consent in the form of a Return Authorization from our Quality Assurance Department, stating why the item is being returned and how the item will be shipped.

Unauthorized returns will be automatically refused by our receiving department as well as returns not in accordance with Bernhardt Design shipping instructions. Liability for defective merchandise shall be limited to the replacement or repair of that merchandise, and Bernhardt Design shall not be liable for other damages or losses.

Terms and Credit

Pricing and terms of sale apply to orders accepted by Bernhardt Design, and no terms, stipulations, or conditions contained in the dealer's submitted purchase orders shall have any force or effect. Bernhardt Design requires a completed and signed credit application from every dealer. Bernhardt Design also requires dealers to provide a Blanket Certificate of Resale/Use containing valid sales tax exemption number(s) for their respective state(s).

If credit has been approved, the standard terms for all Bernhardt Design products are Net 30 from the invoice date. In certain instances, as an additional condition of order acceptance, buyer may be required to provide a deposit at time of order and/or remit the balance before shipment is released. If credit has not been approved, a 100% prepayment, including any freight charges, is required prior to production. Acceptable forms of payment include a certified check or electronic bank transfer. For information on where to send check/electronic bank information contact our Financial Services Department. If a dealer or company check is submitted, three (3) weeks should be allowed for the clearance of the check. If electronic bank transfer is submitted, one (1) week should be allowed for the clearance of the electronic bank transfer. The order is subject to cancellation if payment in full is not received within three (3) weeks from the acknowledgment date.

The dealer may not make deductions for advertising, promotions, quality problems, freight, or any other reason without prior authorization by Bernhardt Design. Such a deduction could result in the curtailment or suspension of further shipments until the matter is resolved. Delinquency notices are generated and mailed periodically. Service charges of 18% per annum will be added to each past-due transaction. Unpaid service charges will be accrued and invoiced on a periodic basis. Past-due notices may result in orders being held until the situation is resolved. This credit hold could prevent orders from being placed into production or shipped. Orders not in production that are placed on credit hold for three (3) weeks will be subject to cancellation.

Severe past-due situations may result in the employment of a collection agency or other collection litigation. If any collection activity is necessary regarding a dealer account, the dealer will be responsible for the payment of any and all attorney and collection agency fees.

A slow payment history may result in reducing or eliminating an open line of credit. At the discretion of Bernhardt Design, amounts owed by a dealer to Bernhardt Design arising from any transaction or dealings between the dealer and Bernhardt Design may be offset against any amounts owed to the dealer by Bernhardt Design.

Warranty - Bernhardt Design

Bernhardt Design will repair or replace, at its discretion, to the original purchaser, any seating product or part thereof which fails as the result of defects in material and workmanship, under single shift use and normal care, for five years from date of shipment, with the exception of guest and stacking chairs which will be warranted for three years.

This warranty does not cover misuse or abuse of product, damages caused by contact with tables, desks or other surfaces, or normal wear associated with use of product. Repair or replacement of discontinued product will be at the discretion of Bernhardt Design.

Natural color changes, variations or movements in lumber or veneer products, exposure to extreme temperature changes and direct sunlight may cause color changes and/or surface damage. These are circumstances beyond the control of Bernhardt Design and are not warranty issues. Repair or replacement of discontinued product will be at the discretion of Bernhardt Design.

Certain chair styles with exposed wood require construction methods that accent color variations in light and natural stains. These variations are not considered product defects and are not warranty issues.

Damages to stacking chairs caused by stacking/unstacking methods are not controllable by Bernhardt Design and are not considered warranty issues.

This warranty is the customer's exclusive remedy for product defect and does not apply to damage caused by a carrier, dealer, installer, user modification, attachments to a product, or any third party.

Bernhardt Design has the exclusive right to make the final determination of product misuse or abuse.

This warranty excludes fabrics, leathers and any other textiles for wearing quality, color fastness, shrinkage, wrinkling, stretching, or dye lot match.

Except as stated above, Bernhardt Design makes no express or implied warranties as to any product, and in particular, makes no warranty of merchantability or of fitness for any particular purpose.

Bernhardt Design shall not be liable for any consequential or incidental damages or for commercial loss arising from any product defect.

Warranty - PLANK

Plank will repair or replace, at its discretion, to the original purchaser, any seating product or part thereof which fails as the result of defects in material and workmanship, under single shift use and normal care, for three years from date of shipment for indoor products and two years for outdoor products.

Parts Order

Bernhardt Design parts have a \$25 net minimum per order. This does not include freight costs.

Custom Design

Bernhardt Design may alter some of its products to meet specific needs. Contact your Bernhardt Design sales representative when a custom design is needed. Custom designs, **if approved**, require minimum quantities, additional leadtime and upcharges.

A custom job number, available from your Bernhardt Design sales representative, must be submitted with purchase orders. Orders combining custom design with standard product cannot be scheduled for production until custom items are approved.

Custom design orders are not subject to revision or cancellation after acknowledgment.

Customer's Own Material (COM) - Customer's Own Leather (COL)

Due to aesthetic reasons or application restraints, Bernhardt Design must preapprove COM/COL fabrics for application on certain Bernhardt Design products. Reference the individual product details for frames requiring preapproval.

Certain fabric types require COM approval for use on any frame. The fabric types include, but are not limited to, thin fabrics without backing such as nylon or linen, parachute cloth, woven grass cloth or transparent materials, and heavier fabrics such as "rug" weight and thick mohair.

Fabrics with more than 40% silk content will not be accepted.

Preapproval Procedures

Please submit a 12" X 12" sample for testing prior to the actual shipment of COM/COL to Bernhardt Design.

Exception: Certain Neighborhood frames require additional yardage for testing. See product for details.

Shipping Address For Samples:

**Bernhardt Design
1839 Morganton Blvd. SW
Lenoir, NC 28645
Attn: Customer Service**

Along with the COM/COL sample, the product number, quantity of products, and contact information must be specified.

Bernhardt Design reserves the right to reject any covering which in our opinion is unsuitable for upholstery purposes.

However, Bernhardt Design shall in no instance be held responsible for tailoring variances that result from the application of a particular textile or leather to a specific frame.

COM Yardage Specifications

All yardage requirements shown in the price list are based on 54" plain material. Fabrics with a vertical repeat that must be matched, or that are less than 54" wide, require more yardage.

COM Yardage Specifications

The chart below should be used for determining additional COM yardage requirements.

Fabric Yardage Vertical Repeat					
Fabric Width	Plain Fabric	2"-10" Repeat	11"-20" Repeat	21"-25" Repeat	26"-30" Repeat
54"	0%	10%	15%	20%	25%
51-53"	15%	20%	25%	30%	35%
48-50"	30%	35%	40%	45%	50%
45-47"	45%	50%	55%	60%	65%
36-44"	60%	65%	70%	75%	80%

Please add the indicated percentage to the yardage shown beside the style number in the price list. This guide will accurately cover most COM orders, but there will be instances due to unusual repeats or designs that additional yardages may be required.

When specifying a COM fabric that is more than 54" wide and includes a vertical and horizontal repeat, contact the Bernhardt Design office for additional yardage requirements. Bernhardt Design will not be held responsible for the purchase of any additional COM that may be required.

When specifying more than one textile on seating items, such as contrasting fabrics, welts, and contrasting welts, additional yardage may be required due to fabric yield.

When ordering multi-item modular configurations, the total COM/COL yardage must be provided from the same dye lot in a continuous roll(s).

All COM's will be cut and applied at the discretion of Bernhardt Design unless special cutting instructions are included in writing with the purchase order. Fabric patterns must be identified as horizontal or vertical application.

Bernhardt Design will not be held responsible for defective fabrics, as all COM's are accepted as first quality goods.

COL Specifications

Leather (COL) requirements are shown in square feet and calculated for hides that are 40 square feet or above. For hides below 40 square feet add 15% to the footage requirements. For calf hides below 30 square feet add 30% to the footage requirements. Bernhardt Design will not be held responsible for receipt of defective leathers, as all COL's are accepted as first quality goods.

COM/COL Tagging

All COM/COL must be properly tagged on the receiving documents in order for Bernhardt Design to match your fabric with your order.

Bernhardt Design will not be responsible for any delays caused by fabric not correctly marked.

COM/COL Tagging

Dealer: _____
 Tagged for: _____
 Product No.: _____
 P.O. No.: _____
 Ack. No.: _____

COM/COL Shipping Address:

**Bernhardt Design
 Plant # 7T Door #10
 1402 Morganton Blvd. SW
 Lenoir, NC 28645**

COM/COL Disclaimer

Bernhardt Design is not responsible for any unclaimed COM/COL 30 days after shipment of Bernhardt Design acknowledgment. It is the responsibility of the dealer to request the return of excess COM/COL on the initial purchase order.

Contrasting Fabric and Welt Upcharges

Bernhardt Design must approve contrasting fabric and welt applications. If approved, the following upcharges apply:

- Single chairs and seats: \$75.00 Net each
- Two or more connected seats: \$125.00 Net each

Exceptions: Reference individual product skus for exceptions to contrasting fabric/welt upcharges.

Flammability

It is the responsibility of the dealer to advise Bernhardt Design of local fire code requirements for final shipping destinations at the time of order placement.

Bernhardt Design certifies that all upholstered products in our current Seating Price List comply with California Technical Bulletin 117-2013, as manufactured, when upholstered in Bernhardt Textiles.

All upholstered products in our current Seating Price List comply with California Technical Bulletin 117-2013, as manufactured, when upholstered in customer's own material which complies with California Technical Bulletin 117-2013.

Substitutions of customer's own material for Bernhardt Textiles are accepted at customer's risk. Contact your Bernhardt Design sales representative for other flammability requirements and upcharges.

Bernhardt Design will not be responsible for any changes in color or appearance of fabrics with special treatments, nor for replacement of goods damaged during treatment process.

Seating Materials

Bernhardt Design guest seating is constructed of kiln dried solid maple parts except as noted in the price list. These solid maple parts are double doweled, utilizing corner blocks and lag bolts on the seat frame. The seat consists of high resilience urethane foam over woven webbing.

Stretchers, which enhance product durability in high use public areas, are available on selected Bernhardt Design exposed wood seating products.

Contact your Bernhardt Design sales representative for information regarding applicable upcharges for the addition of stretchers to chairs that are intended to be used in areas such as restaurants, cafeterias, training centers, hotel/motels, and other applications where chairs would be subject to above normal movement and use.

Bernhardt Design lounge seating is constructed from kiln dried lumber using double and triple dowel methods. High resilience urethane foam is used in conjunction with polyester fiber filling. Exposed wood components consist of maple, walnut, or parawood solids.

Bernhardt Design offers high and low back swivel chairs with pneumatic gas lifts and tilt controls and five star aluminum bases.

Wood Finishes

Bernhardt Design seating is available in finishes that are compatible with credenza and table finishes. However, finishes on tables may vary slightly from those on seating due to the natural characteristics of the wood. No absolute match is implied or guaranteed.

Light Finishes

Bernhardt Design offers lighter finishes on certain veneers and solid woods. When specifying light finishes the natural characteristics of the wood will be visible and color will vary.

Natural characteristics include the natural discolorations of the wood substance and color variations in glued up stock. These natural characteristics are not considered defects by Bernhardt Design, and therefore merchandise will not be replaced.

Standard Finishes

Finishes must be specified on all orders. The following finishes are available:

Maple

805	845	870
823	860	871
836	861	872
837	865	
839	866	

Oak/Ash

805	839	861	870
836	845	865	871
837	860	866	872

Oak/Ash Select Finishes

M71	M74	M76
M73	M75	M77

Walnut

823	861	872
839	866	LV8*
860	870	

Exceptions. *Reference individual product skus for applicable finishes.

Special Finishes

Special finishes, made to customer specifications and subject to factory approval, may be available at a **10% net upcharge with a \$500 net minimum.**

Contact your Bernhardt Design sales representative when a special finish is desired. When ordering a special finish, additional lead times may be required. Special finishes cannot be cancelled after acknowledged by Bernhardt Design.

Care and Cleaning - Bernhardt Design

Finished wood surfaces should be cleaned with a soft damp cloth, wiping in the direction of the grain. Dry with a soft cloth, wiping in the grain direction. Do not use waxes or furniture polish as these will cause an unsightly film build-up.

Care and Cleaning - PLANK

Indoor products should be regularly be cleaned and dried. Finished wood surfaces should be cleaned with a soft damp cloth, wiping in the direction of the grain. Dry with a soft cloth, wiping in the grain direction. Do not use waxes or furniture polish as these will cause an unsightly film build-up.

It is recommended that outdoor furniture be cleaned, particularly when dark liquid or substances are spilled. Liquids or other spilled materials must be removed immediately with a soft cloth or damp sponge. To remove any residue, a little lukewarm water can be used with a small amount of fabric softener. Do not use solvents containing alcohol or abrasive cleaners (scouring sponges). The substances can permanently change the appearance of any material.

Direct sunlight as well as direct heat sources (i.e. radiators, flames) on a lasting basis will strain materials and change their original color. Also, regularly drying outdoor furniture helps maintain original product quality and appearance.

Wood Iroko: For gentle cleaning and refreshing purposes, we recommend an annual treatment with wood care oil.

Design and Patent Rights

All of the products shown in Bernhardt Design catalogs and described in Bernhardt Design price lists are, and remain, the property of Bernhardt Design, with the sole right reserved to manufacture and to distribute.

Some of the product designs shown are patented in the United States and will remain the property of Bernhardt Design. Any reproduction of the products constitutes an infringement of patented copyright laws and will be subject to prosecution.

Environmental

Some seating products are LEVEL® for ANSI/BIFMA e3-2019 – Furniture Sustainability Standard and SCS Indoor Advantage™ Gold certified. Visit the product page at bernhardtdesign.com for certifications.

Preferred Carrier Guaranteed Freight Rates

Freight charges will be applied to orders as a separate line item based on the zones listed. Rates are based on zones with a minimum for each zone. All zones are located within the Continental United States.

The freight amount is calculated on the total merchandise list COM price. Additional freight fuel surcharges may apply. Rates are based on deliveries made Monday through Friday, 8 am until 5 pm.

All orders are shipped by Bernhardt Design company trucks or preferred carriers specified by Bernhardt Design. **If a purchase order does not specify that the product must ship complete, Bernhardt Design reserves the right to select the most effective shipping method necessary, including split shipments.** Dealer warehouse information, including phone number and contact name, must be specified on the purchase order.

Zone	Percent	Minimum
Zone 1	3%	\$150
Zone 2	4%	\$150
Zone 3	5%	\$150
Zone 4	5.5%	\$150
Zone 5	6%	\$150

Percent bases on List Price.

Direct site deliveries may be requested with an additional freight cost. Requests for direct site deliveries must be made 2 weeks prior to the scheduled ship week and meet the following criteria:

- Minimum of half truckload
- Delivery site accessible by a 53' trailer
- Complete delivery site address with contact name and on-site phone number
- Labor available for unloading

Deliveries that do not meet the criteria must be directed to a receiver warehouse. If a receiver warehouse is not available, the dealer may make arrangements with their own 3rd party carrier. If a 3rd party carrier is elected, a contact name, phone number and e-mail address is required.

Weekend direct site deliveries will incur a \$500 per trailer weekend delivery fee. Weekend is defined as between 5 pm Friday and 8 am Monday.

Customers who decline GFP should refer to the shipping section of the Terms and Conditions page.

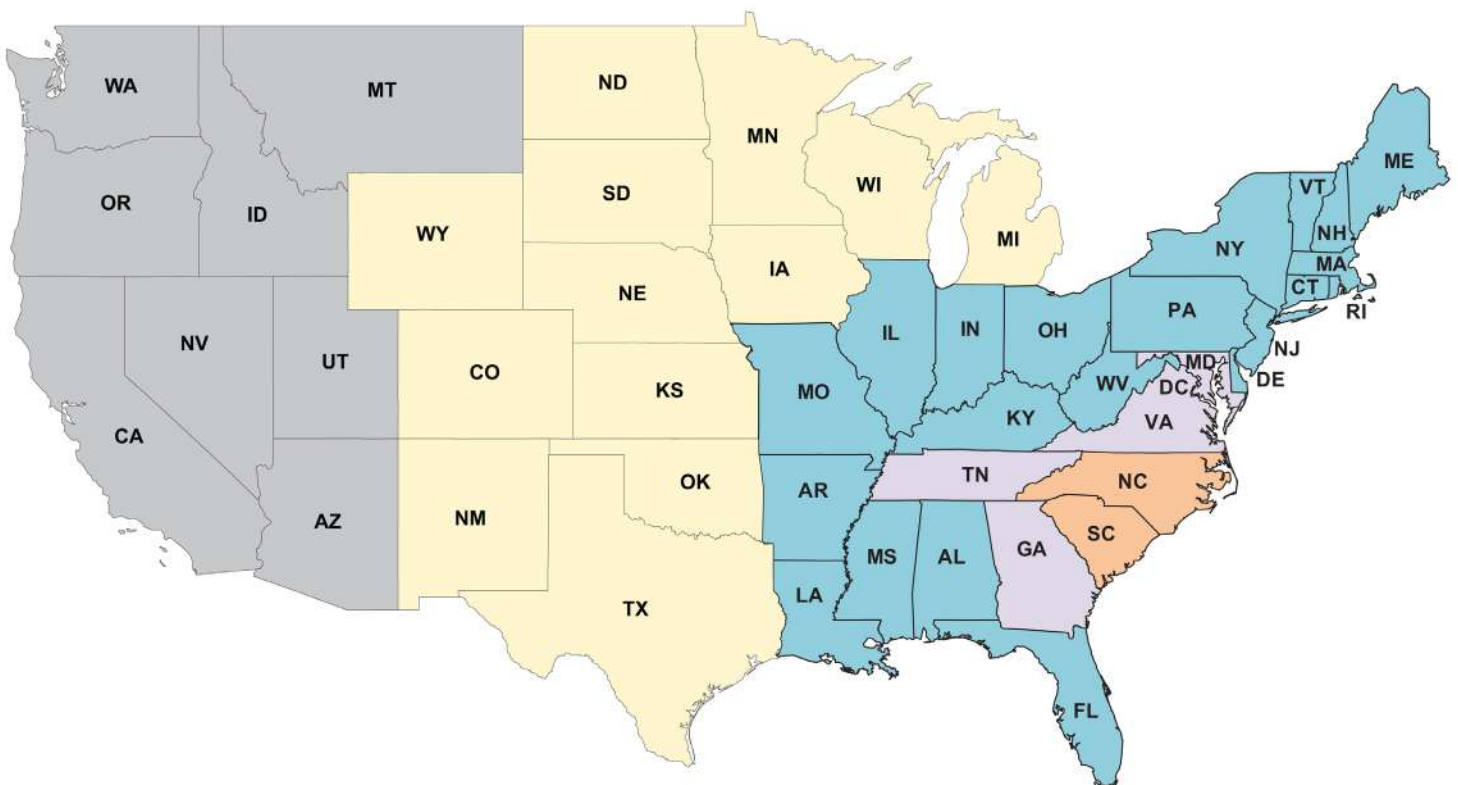

Preferred Carrier Guaranteed Freight Rates - Canada

Freight charges will be applied to orders as a separate line item based on the zones listed. Rates are based on zones with a minimum for each zone.

The freight amount is calculated on the total merchandise list COM price. Additional freight fuel surcharges may apply. Rates are based on deliveries made Monday through Friday, 8 am until 5 pm.

All orders are shipped by Bernhardt Design company trucks or preferred carriers specified by Bernhardt Design. **If a purchase order does not specify that the product must ship complete, Bernhardt Design reserves the right to select the most effective shipping method necessary, including split shipments.** Dealer warehouse information, including phone number and contact name, must be specified on the purchase order.

Direct site deliveries may be requested with an additional freight cost. Requests for direct site deliveries must be made 2 weeks prior to the scheduled ship week and meet the following criteria:

- Minimum of half truckload
- Delivery site accessible by a 53' trailer
- Complete delivery site address with contact name and on-site phone number
- Labor available for unloading

Deliveries that do not meet the criteria must be directed to a receiver warehouse. If a receiver warehouse is not available, the dealer may make arrangements with their own 3rd party carrier. If a 3rd party carrier is elected, a contact name, phone number and e-mail address is required.

Weekend direct site deliveries will incur a \$500 per trailer weekend delivery fee. Weekend is defined as between 5 pm Friday and 8 am Monday.

Customers who decline GFP should refer to the shipping section of the Terms and Conditions page.

Zone	Minimums	Freight	Avg. Bus. Days
Zone 1	\$200	5%	10-15
Zone 2	\$200	9%	10-15
Zone 3	\$200	8%	10-15
Zone 4	\$200	11%	10-15
Zone 5	Quote	Quote	

The attached rates are strictly freight and do not include brokerage fees.

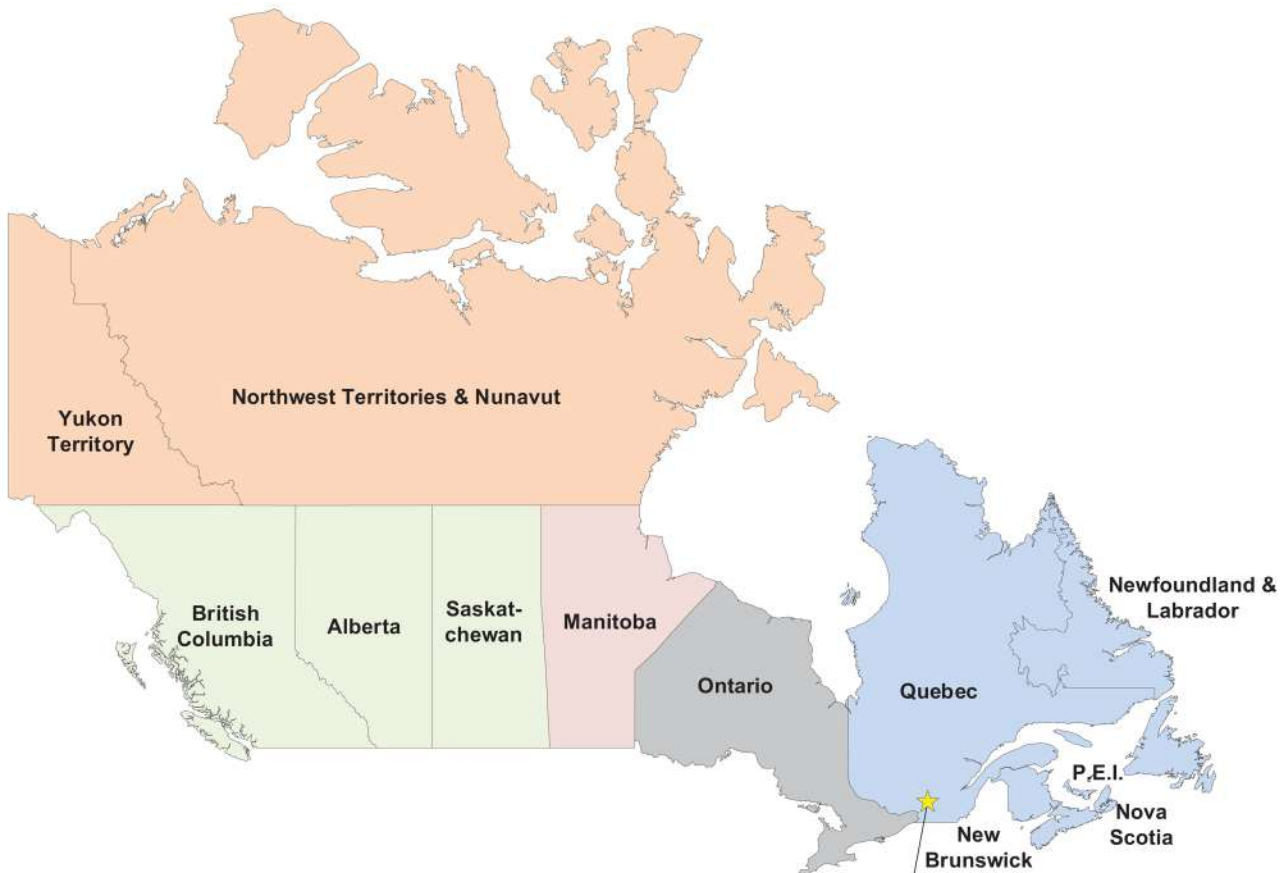

Greater Montreal Quebec Area (Postal Codes Starting with H) Freight is 5%