

anza
price list

january 2025

index	2
laminare selection	3
veneer selection	4
design selections + powder coat	5
overview + base selection	6
tops + power overview	7
tops	8
triad surface mount power module + grommet placement	9
mediatrac™ power	
power overview	10
grommet placement kits:	11
laminare, veneer, solid surface	12-13
back-painted glass	14-15
wire management	16-17
terms and conditions	18-20
guaranteed freight	21
guaranteed freight - canada	22

Laminate Selections

A three character sku identifies each laminate selection as well as the standard finish offered. Individual components are priced with standard finish on standard laminate.

A variety of Wilsonart® standard laminates with standard finishes is offered on conference and multipurpose tables. Additional colors may be available but are

subject to upcharges and extended lead times. The laminate option is available on components where noted as an option in the material specification code.

All laminate tops will have a 3mm matching edge band.

PLL Solid Laminate

Standard Solid

- 671 Designer White, Wilsonart D354-60 Matte Finish
- 672 Frosty White, Wilsonart 1573-60 Matte Finish
- 673 Fashion Grey, Wilsonart D381-60 Matte Finish
- 674 North Sea, Wilsonart D90-60 Matte Finish
- 675 Black, Wilsonart 1595-60 Matte Finish

20% Upcharge

- 665 Snow White Velvet, Wilsonart 15501-31 Traceless Laminate
- 666 Charcoal Velvet, Wilsonart 15504-31 Traceless Laminate
- 667 Black Velvet, Wilsonart 15505-31 Traceless Laminate

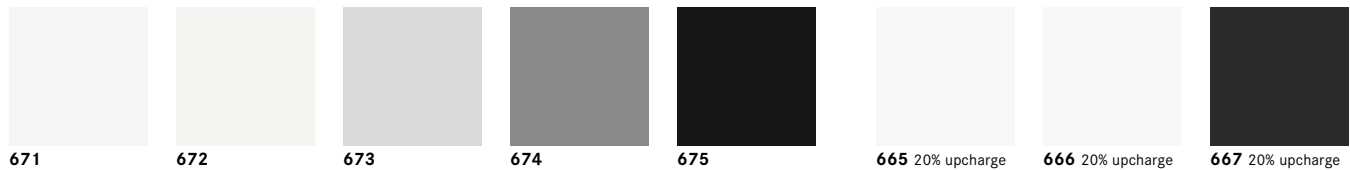

WGL Woodgrain Laminate

Standard Woodgrain

- 684 Phantom Pearl, Wilsonart 8211K-28 Gloss Line Finish w/Aeon Scratch Resistant Protection
- 685 Raw Chestnut, Wilsonart 7975K-12 Soft Grain Finish w/Aeon Scratch Resistant Protection
- 686 High Line, Wilsonart 7970K-18 Linearity Finish w/Aeon Scratch Resistant Protection
- 678 New Age Oak, Wilsonart 7938-16 Casual Rustic Finish
- 679 Brazilwood, Wilsonart 7946-38 Matte Finish
- 687 Boardwalk Oak, Wilsonart 7983-38 Fine Velvet Finish
- 683 Portico Teak (Grey), Wilsonart 8210K-28 Gloss Line Finish
- 681 Studio Teak, Wilsonart 7960-16 Casual Rustic Finish
- 680 Walnut Heights, Wilsonart 7965K-12 Soft Grain Finish
- 682 Asian Night, Wilsonart 7949-16 Casual Rustic Finish



Veneer Selections

A three character sku identifies each species as well as the standard finish offered. Individual components are priced with standard finish. Special finishes on veneers made to customer specifications are subject to factory approval and a 10% net upcharge with a \$500 net minimum.

Transparent stains and sealers are applied in multiple steps to enhance the beauty of the natural wood. A durable, baked-on, top-coat of conversion varnish

or UV topcoat is applied to protect the product. It is recommended that felt, cork or fabric backed desk pads and accessories are used on worksurfaces to minimize wear.

When specifying light finishes the natural characteristics of the wood will be visible and color will vary. Paint finishes are available as custom orders. See terms and conditions for additional finish information.

OAK Oak

Rift Cut

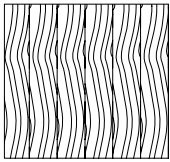

Standard Finish

- 871 870 839
- 837 860 861
- 865 836 866
- 872 805 845

WLT Walnut

Flat Cut

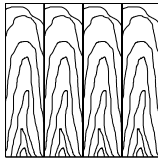

Standard Finish

- 872 861
- 870 823
- 860 866
- 839

OAK Select Finishes

- M73 M72 M75
- M74 M76 M77
- M71

OAK Oak



871

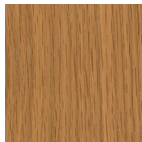

837



865

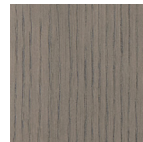

872

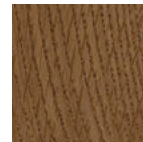

870

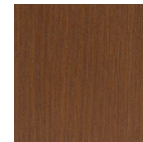

860

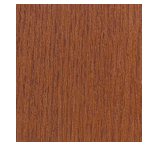

836

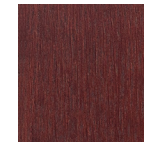

805

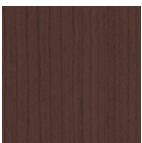

839



861



866



845

OAK Select Finishes



M73 Whitewash

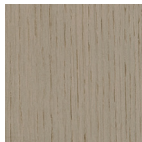

M74 Fawn



M71 Blonde

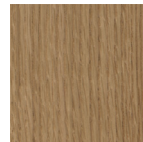

M72 Toast

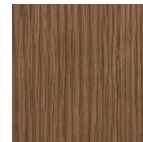

M76 Caramel

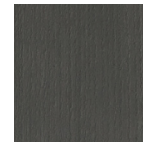

M75 Smoke



M77 Coffee

WLT Walnut

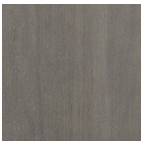

872

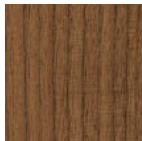

870



860

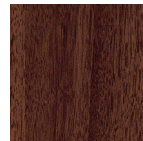

839

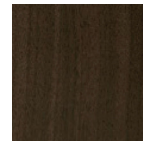

861

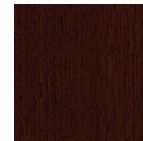

823



866

Design Selections

Glass Selections

GPW Back-Painted White Glass - 1/2" thick

GEW Etched, Back-Painted White Glass - 1/2" thick

Solid Surface Selection

SSF Solid Surface

Standard Finish

CGW Corian®, Glacier White

Powder Coat Finishes

A two character sku identifies each powder coat finish offered. Individual skus are priced with standard metal finish. Non-standard finishes may incur an additional charge. The powder coat option is available on skus where noted as an option in the material specification code.

Standard Finish



PA Polished Aluminum

Powder Coat Finishes - Upcharges apply.

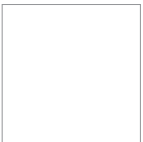

WH Satin White



GR Graphite

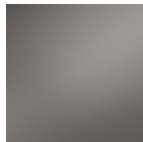

BZ Bronze



IG Iron Grey



RD Black Red



BK Matte Black

Optional Powder Coat Colors - RAL

- Lead Time - Three weeks additional lead-time after color approval
- Net Up-charge - \$1000 for colors shown in Bernhardt Design RAL Powder Coat Selector
- Minimum Order Quantity - None
- Approval Sample Cost - None
- Combining Products - One up-charge is applicable for multiple products on a single purchase order when they are in the same color

Anza

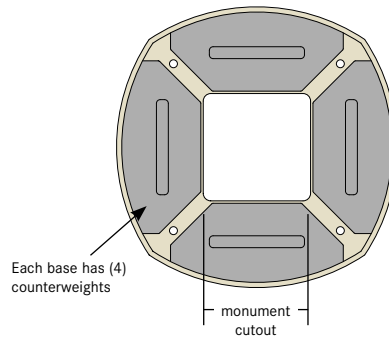

Monument Cutout

18½"	6¾" x 6¾"
22¾"	10¼" x 10¼"
24"	11¼" x 11¼"

Top view showing monument cutout and counter weight details

The Anza meeting table features a bent plywood base with adjustable levelers. The base is available in oak and walnut veneer and features (4) 30 lbs. counterweights.

Anza bases and tops are specified and sold separately.

SCS Indoor Advantage™ Gold and LEVEL® 2 certified. See terms and conditions for additional environmental information.

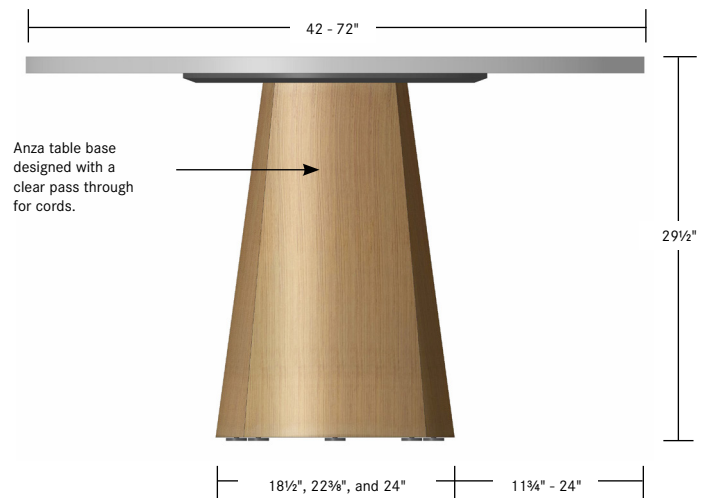

Front View Anza Table

	description	sku	w	d	h	weight	price
	anza base	FBS	18½	18½	28½	26	\$ 4172
	bent plywood	FBM	22¾	22¾	28½	46½	4519
	adjustable levelers	FBL	24	24	28½	50	4866
	bases are specified per top size						

specification codes example: AZS-SKU

series	sku
anza	
A Z S -	

material + finish code example: OAK 805

base material	base finish
OAK oak WLT walnut	see page 4

Anza Tops



Anza tops are specifically constructed to accommodate the Anza table base. Round tops sizes from 42" to 72" and arched square tops from 42" to 60". The Anza table is designed to accommodate the 8" double door, corded Mediatrix™ grommet and Triad surface mount power module.

Laminate

- PLL Solid Laminate
- WGL Woodgrain Laminate

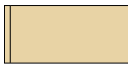

FL 1/4" Flat



RB 1/4" Reverse Bevel

Veneer

- OAK Oak
- WLT Walnut

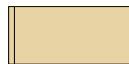

FL 1/4" Flat



RB 1/4" Reverse Bevel

Glass

- GPW Back-Painted White Glass
- GEW Etched, Back-Painted White Glass

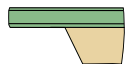

PF 1/2" Polished Flat

Solid Surface

- SSF Corian®, Glacier White

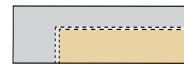

FL 1/4" Flat

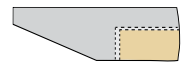

RB 1/4" Reverse Bevel

3" Grommet Pass Thru

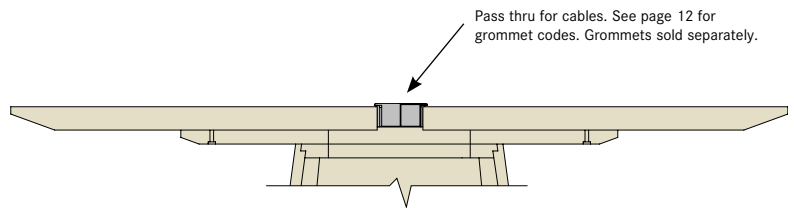

Detail view of the Anza top and base with 3" Grommet pass thru.

Triad Surface Mount Power Module

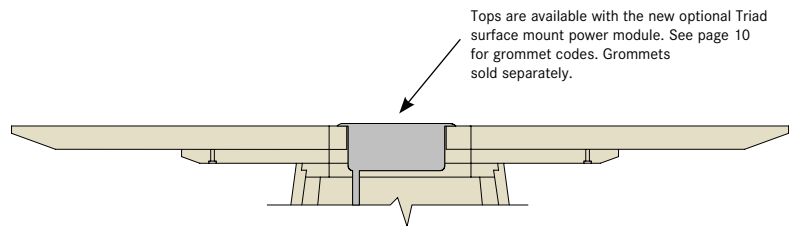

Detail view of the Anza top and base with the Triad surface mount power module.

Mediatrix1™

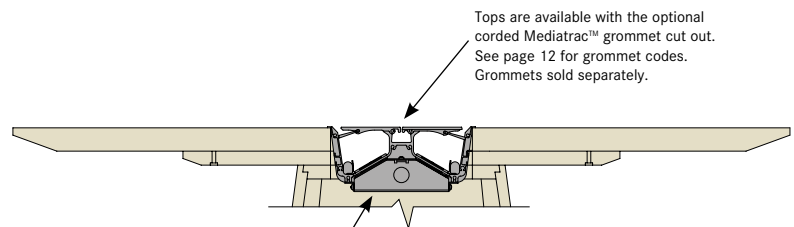

The base is designed to provide clearance for a corded Mediatrix1™ grommet.

Detail view of the Anza top and base with the corded Mediatrix1™ grommet.

specification codes example: QTS-SKU-FLAZ000

series	sku	edge	base	grommet location
top		FL 1/4" flat PF 1/2" polished flat RB 1/4" reverse bevel	AZ anza	Mediatrix1™ see page 12-15 R01 Triad surface mount power Specify Triad power style separately - see page 9 000 none
Q T S -	-		A Z	

material + finish code example:

top material	top
PLL solid laminate WGL woodgrain laminate OAK oak WLT walnut GPW glass back-painted white GEW glass etched back-painted white SSF glacier white	WLT 839 see pages 3-5



tops sold separately
order bases separately

sku | l | w | specifications

PLL solid laminate WGL woodgrain laminate		OAK oak WLT walnut		GPW back-painted white glass	GEW etched back-painted white glass	SSF solid surface	
FL	RB	FL	RB	PF	FL	RB	

arched square top

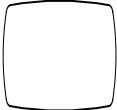

BBB	42	42	use with base FBM	\$ 1290	\$ 1677	\$ 2699	\$ 3158	-	-	\$ 5212	\$ 6099
BCC	48	48	use with base FBM	2058	2676	3109	3638	-	-	5554	6499
BDD	54	54	use with base FBL	2409	3132	3364	3936	-	-	6637	7766
BEE	60	60	use with base FBL	2799	3639	3582	4191	-	-	8070	9442

round top

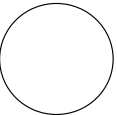

DBB	42	42	use with base FBS	1290	1677	2699	3158	6114	7460	5091	5957
DCC	48	48	use with base FBS	2058	2676	3117	3647	7703	9398	5554	6499
DDD	54	54	use with base FBM	2409	3132	3399	3977	9433	11509	6790	7945
DEE	60	60	use with base FBM	2799	3639	3616	4231	11165	13622	8070	9442
DFE	66	66	use with base FBL, two piece top	4329	5628	5147	6022	-	-	-	-
DGG	72	72	use with base FBL, two piece top	4718	6134	5537	6479	-	-	-	-

specification codes example: QTS-SKU-FLAZ000

series	sku	edge	base	grommet location	material + finish code example: WLT 839
top		FL 1/4" flat PF 1/2" polished flat RB 1/4" reverse bevel	AZ anza	Mediatrac™ see page 12-15 R01 Triad surface mount power Specify Triad power style separately - see page 9 000 none	top material PLL solid laminate WGL woodgrain laminate OAK oak WLT walnut GPW glass back-painted white GEW glass etched back-painted white SSF glacier white top finish see pages 3-5
Q T S -	-		A Z		

Triad Surface Mount Power Module

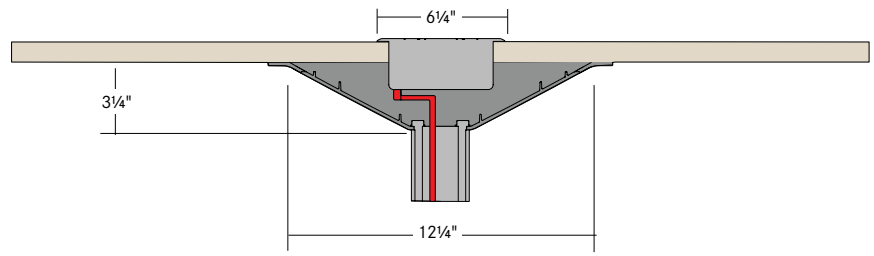

Note: End user installation will be required per individual SKU. Power specified separately.

The new Triad surface mount power module offers a simple and clean way of bringing power and USB to the worksurface.

The Triad surface mount power module installs flush to the worksurface. It features (3) receptacles, (3) USB-A ports and (3) USB-C ports. Module is available in matte black or satin white finishes.

When specifying Triad Round Surface Power for table assemblies use R01 grommet kit code.

The power module is UL approved with spill-proof technology and a 15 amp, 10' power infeed. Power module is certified to UL STD 962 A CSA SDT 22.2 No.21.

Triad Power Module- Power + USB

Updated Information Shown in RED

- Matte Black or Satin White Finish
- (3) 120v 60 Hz. 15 amp Receptacles
- (3) 2 amp USB-A ports, 10 watt**
- (3) 2 amp USB-C ports, 20 watt**
- 10' cord, 15 amp
- 6 1/4"w x 6 1/4"d x 2 1/2"h
- Specify power style **TPU**

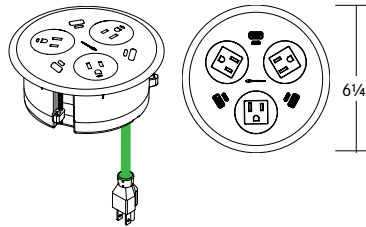

Power Style
TPU
(3) receptacles (3) 2 amp USB-A ports, 10 watt (3) 2 amp USB-C ports, 20 watt

sku specifications

R01	42" - 72" Tables	42" - 60" Tables	\$ 1880
R01	42" - 60" Tables		1880

specification codes example: ACS-R01-TPU

series	sku	power style
accessories		TPU power + usb
A C S -	R 0 1 -	T P U

finish code example: WH

finish
BK matte black
WH satin white

Mediatrac 1™

Mediatrac 1 grommet system is a simplified system for bringing power and data to the meeting table worksurface in a clean simple way.

Mediatrac 1 provides power and various options for Extron AAP data configurations. Grommets are available in a 8" x 8" double door unit. All units have brushed aluminum trim with options for aluminum, laminate, veneer, corian and glass lids.

Mediatrac 1 has 4 different options for bringing power to the table, corded, harded or 4-trac system with either a corded or hardwired power infeed.

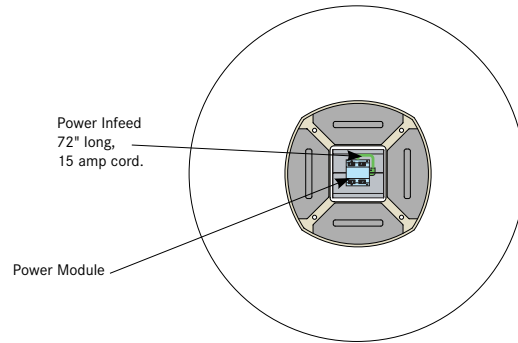

Note: End user installation will be required per individual SKU. Power specified separately. See page 12-15 for grommet codes.

Mediatrac 1 Options

8" Double Door Mediatrac™ Grommet

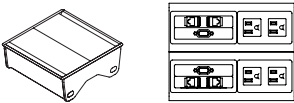

4 grounded outlets, 1 exit plug, accepts 4 Extron single space AAP's, AAP modules specified separately, brushed aluminum frame

Mediatrac 1 Grommet Kits (Includes the Following)

Power Module

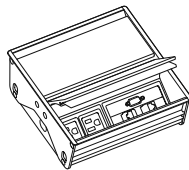

Number and configuration of grommet modules determined by the grommet code

Power Infeed Options

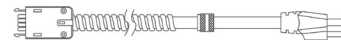

72" 4-Trac Power Infeed with 20 amp plug



20 amp receptacle
4-Trac Only



72" 4-Trac Power Infeed with Hardwired



15 amp receptacle

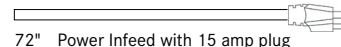

72" Power Infeed with 15 amp plug



72" 3/8" Hardwire Whip

Mediatrac 1 Dimensional Specifications

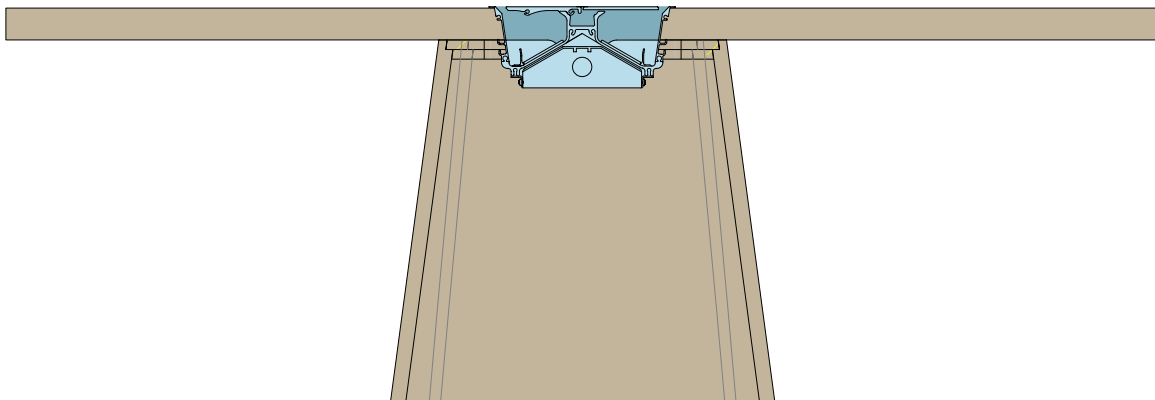

Mediatrac 1 is certified to UL STD 962A, UL STD 1363, CSA STD 22.2 No. 308-14. 4-Trac is certified to UL STD 183 CSA STD 22.2 No. 203.1-14.

Mediatrac1™ Grommet Placement Kits

Mediatrac1™ power options by Bernhardt Design are offered as a grommet kit which includes all grommets, jumpers and necessary components needed to bring power from the floor to the user. The number of grommets and lengths of jumpers are determined by the lengths and power options selected. Your kit will come complete with all necessary parts to install in the field.

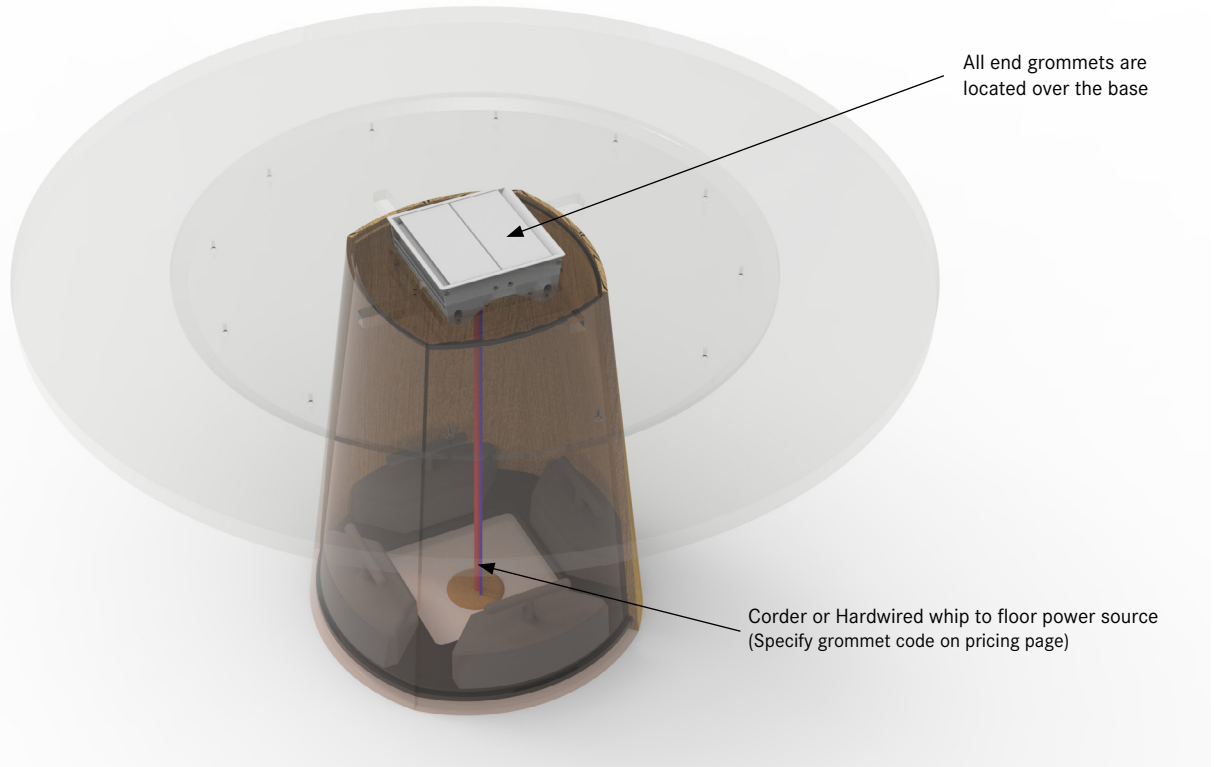

Ordering Mediatrac1 Grommets

- Determine the amount of power and data needed
- Select the grommet code that best suits your requirements
(make sure that this grommet code matches the code used when ordering your top)
- Select the type of power infeed you need
- Select the grommet trim/frame finish
- Select the lid/door material
- Select the lid/door finish

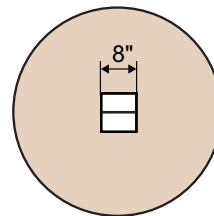

Ordering Example:

Round Table Top
Walnut veneer, 870 finish
M03 Grommet Code with corded power
Walnut Door/Brushed Aluminum Trim

The Grommet Kit will ship separately and will be installed in the **field**.

specification codes example: **MGS-M03-CRD**

series	sku	power option
top		CRD corded HWD hardwired
M G S -	M 0 3 -	C R D

material + finish code example: **BA WLT 870**

frame finish	lid material	lid finish
BA brushed aluminum WH satin white powder coat GR graphite powder coat BZ bronze powder coat IG iron grey powder coat RD black red powder coat BK matte black powder coat power coat upcharge \$75	ALM aluminum PLL solid laminate WGL woodgrain laminate MPL maple OAK oak WLT walnut SSF glacier white	see pages 3-5
B A	W L T	8 7 0

Mediatrac 1 grommet kits and locations codes for veneer, laminates and solid surface tops.
Kits include all jumpers and necessary components based on table length and power option.
Grommet kits ship separately from tops.

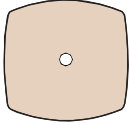
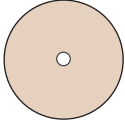
sku	specifications	frame material
		ALM aluminum
M01	42" - 60" Table	\$ 154
	(1) 3" single round pass through grommet kit	
		
	42" - 72" Table	154
	(1) 3" single round pass through grommet kit	
		

specification codes example: ACS-SKU

series	sku
top	
A C S -	-

material + finish code example: BA

frame finish
BA brushed aluminum
WH satin white powder coat
GR graphite powder coat
BZ bronze powder coat
IG iron grey powder coat
RD black red powder coat
BK matte black powder coat

Mediatrac 1 grommet kits and locations codes for veneer, laminates and solid surface tops. Kits include all jumpers and necessary components based on table length and power option. Grommet kits ship separately from tops.

Specify table length, power style, lid material and frame finish below.

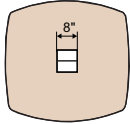
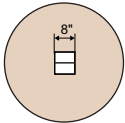
sku	specifications	lid material		
		ALM aluminum	PLL solid laminate WGL woodgrain laminate	OAK oak WLT walnut SSF solid surface
M03	42" - 60" Table (1) 8" double door mediatrac grommet 	\$ 1999	\$ 2250	\$ 3125
	42" - 72" Table (1) 8" double door mediatrac grommet 	1999	2250	3125

specification codes example: MGS-SKU-CRD048

series	sku	power option	table length
top		CRD corded HWD hardwired 4TC four trac corded 4TH four trac hardwired	048 054 060 066 072
M G S -	-		

material + finish code example: BA WLT 839

frame finish	lid material	lid finish
BA brushed aluminum powder coat upcharge \$75 WH satin white powder coat GR graphite powder coat BZ bronze powder coat IG iron grey powder coat RD black red powder coat BK matte black powder coat	ALM aluminum PLL solid laminate WGL woodgrain laminate OAK oak WLT walnut SSF glacier white	see pages 3-5

Mediatrac 1 grommet kits and locations codes for glass tops.
Kits include all jumpers and necessary components based on table length and power option.
Grommet kits ship separately from tops.

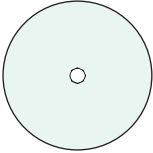
sku	specifications	frame material
01G	42" - 60" Table	ALM aluminum
	(1) 3" single round pass through grommet kit	\$ 154
		

specification codes example: ACS-SKU

series	sku
top	
A C S -	-

material + finish code example: BA

frame finish
BA brushed aluminum
WH satin white powder coat
GR graphite powder coat
BZ bronze powder coat
IG iron grey powder coat
RD black red powder coat
BK matte black powder coat

Mediatrac 1 grommet kits and locations codes for glass tops.
Kits include all jumpers and necessary components based on table length and power option.
Grommet kits ship separately from tops.

Specify table length, power style, lid material and frame finish below.

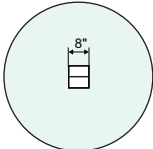





sku	specifications	lid options	
		Aluminum	Glass
03G	42" - 60" Table	\$ 1999	\$ 3125
	(1) 8" double door mediatrac grommet		
			

specification codes example: MGS-SKU-CRD054

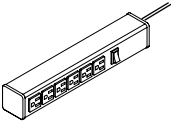

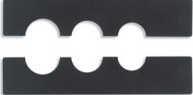



series	sku	power option	table length
top		CRD corded HWD hardwired 4TC four trac corded 4TH four trac hardwired	042 048 054 060
M G S -	-		

material + finish code example: BA GPW

frame finish	lid material
BA brushed aluminum powder coat upcharge \$75 WH satin white powder coat GR graphite powder coat BZ bronze powder coat IG iron grey powder coat RD black red powder coat BK matte black powder coat	ALM aluminum GPW glass back-painted white GEW glass etched, back-painted white

description	sku	w	d	h		price
 <p>power strip</p> <p>6 outlet center; 110v 15 amp 15' plug-in cord surge protector UL Listed</p>	VNY	12¼	2	1¾		\$ 546
 <p>blank plate</p> <p>Extron® AAP blank plate with black powder coat finish single space insert</p>	VGG	3½	-	5⁄8		161
 <p>cable pass-through module</p> <p>Extron® AAP single space, cable pass-through plates sold as a set of (2) black powder coat finish</p>	VGY	3½	-	1¾		459
 <p>phone/data module</p> <p>Extron® AAP two RJ-45 pass-through barrels CAT 5e single space insert</p>	VGD	3½	-	5⁄8		346
 <p>phone/data module</p> <p>Extron® AAP one RJ-45 female to punch down block leviton CAT6 data single space insert</p>	V GK	3½	-	5⁄8		277
 <p>phone/data module</p> <p>Extron® AAP two RJ-45 female to punch down block leviton CAT6 data single space insert</p>	V GP	3½	-	5⁄8		384
 <p>phone/data module</p> <p>Extron® AAP two RJ-45 female to punch down block AMP CAT6 data single space insert</p>	V GL	3½	-	5⁄8		384

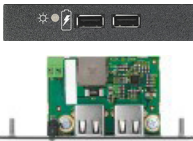
series	sku
accessories	
A C S -	

description	sku	w	d	h	price
 <p>phone/data module</p> <p>Extron® AAP two RJ-45 female to punch down block higher than CAT6 data type connectors systemax MGS500 backward compatible double space insert</p>	VGQ	3½	-	1⅜	\$ 523
 <p>computer/audio/video module</p> <p>Extron® AAP HDMI female to HDMI female on 10" pigtail single space insert</p>	VG3	3½	-	⅝	384
 <p>control/computer module</p> <p>Extron® AAP two USB A female to female barrels single space insert</p>	VGR	3½	-	⅝	384
 <p>power plate charging module</p> <p>type 5 VDC USB C power outlet 3 A/45 watts type 5 VDC USB A power outlet 2.1A/10.5 watts of power for charging mobile devices, single space insert</p>	VG9	3½	-	⅝	1316
 <p>usb charging module</p> <p>Extron® AAP Power Plate charging module 2 5 VCD USB power outlets 2.1 A / 10.5 watts of power for charging mobile devices single space insert</p>	VGU	3½	-	⅝	746
 <p>computer/audio/video module</p> <p>Extron® SuperPlate 110 - HDMI/DisplayPort/Stereo Audio/USB HDMI: female to female, 10" (25 cm) pigtail DisplayPort: female to female, 10" (25 cm) pigtail Stereo/Audio: 3.5 mm mini jack to captive screw, 10" (25 cm) pigtail USB A: female to female, 10" (25 cm) pigtail double space insert</p>	VG6	3½	-	1⅝	610

series	sku
accessories	
A C S -	

Prices and Specifications

Prices and specifications are subject to change without notice. All prices quoted will be FOB our factories. If applicable, sales tax will be based on ship-to destination.

Bernhardt Design reserves the right to make changes in dimensions, construction, price lists, or product literature without prior notice.

All measurements and weights are approximate and subject to change without notice.

Order Entry

All orders are subject to final acceptance by Bernhardt Design in Lenoir, NC. Receipt of our acknowledgment indicates acceptance of your order subject to the terms set forth on the acknowledgment.

Bernhardt Design attempts to clarify all purchase orders. However, in the event the price list number and description on the purchase order differ, the price list number will prevail.

Changes/Cancellation

All orders in production are considered firm orders and are not subject to changes or cancellation.

Shipping

Bernhardt Design will ship in accordance with customer instructions whenever possible. For convenience, Bernhardt Design offers a guaranteed freight program (GFP). Bernhardt Design will exercise our best judgment in selecting a carrier under our GFP. When selecting a carrier, Bernhardt Design will make our best effort to meet requested delivery dates.

Transportation lead-times and delays including equipment problems, weather, general traffic, traffic accidents, customer warehouse space, labor disputes, customer changes, etc., that occur on a carrier will not be the responsibility of Bernhardt Design. Furthermore, Bernhardt Design will not be responsible for additional costs incurred due to aforementioned delays.

For customers who decline our GFP, Bernhardt Design will stage orders for pick up at 1% of the list price, or \$75 minimum.

Customer orders in production will be shipped as scheduled and will not be held. Bernhardt Design reserves the right to make partial shipments on any order, unless notified otherwise by the customer.

High quality cartoning meeting trucking and railroad specifications is standard at no extra charge. Some items may be blanket wrapped for shipment.

Freight Damage and Claims

Bernhardt Design is not liable for any damages to products that occur during transit or storage. The carrier assumes all responsibility upon acceptance of product. It is the customer's responsibility to inspect products upon receipt and file any claims with the carrier. No product should be refused. If products are received damaged, a written exception should be made on the bill of lading and an immediate inspection be requested of the carrier.

Concealed damage must be reported to the carrier within 10 business days from date of delivery. Failure to make claims shall constitute acceptance of the products and waiver any claims of defects, errors or shortages.

In the event delivery is made on a Bernhardt Design truck, the products should be carefully inspected for transit damage. If contents are damaged, the driver should be notified to call his dispatcher for immediate disposition.

Concealed damage must be reported within 10 business days from date of delivery and product/packaging held for inspection by a Bernhardt Design representative. Replacements for product damaged in shipment or storage will be manufactured upon receipt of a purchase order.

Returns

No merchandise may be returned to Bernhardt Design without written consent in the form of a Return Authorization from our Quality Assurance Department stating why item is being returned and how item will be shipped.

Unauthorized returns will be automatically refused by our receiving department as well as returns not in accordance with Bernhardt Design shipping instructions. Liability for defective merchandise shall be limited to the replacement or repair of that merchandise, and Bernhardt Design shall not be liable for other damages or losses.

Terms and Credit

Pricing and terms of sale apply to orders accepted by Bernhardt Design, and no terms, stipulations, or conditions contained in the dealer's submitted purchase orders shall have any force or effect. Bernhardt Design requires a completed and signed credit application from every dealer. Bernhardt Design also requires dealers to provide a Blanket Certificate of Resale/Use containing valid sales tax exemption number(s) for their respective state(s).

If credit has been approved, the standard terms for all Bernhardt Design products are Net 30 from the invoice date. In certain instances, as an additional condition of order acceptance, buyer may be required to provide a deposit at time of order and/or remit the balance before shipment is released. If credit has not been approved, a 100% prepayment, including any freight charges, is required prior to production.

Acceptable forms of payment include a certified check or electronic bank transfer. For information on where to send check/electronic bank information contact our Financial Services Department. If a dealer or company check is submitted, three (3) weeks should be allowed for the clearance of the check. If electronic bank transfer is submitted, one (1) week should be allowed for the clearance of the electronic bank transfer. The order is subject to cancellation if payment in full is not received within three (3) weeks from the acknowledgment date.

The dealer may not make deductions for advertising, promotions, quality problems, freight, or any other reason without prior authorization by Bernhardt Design. Such a deduction could result in the curtailment or suspension of further shipments until the matter is resolved. Delinquency notices are generated and mailed periodically. Service charges of 18% per annum will be added to each past-due transaction. Unpaid service charges

will be accrued and invoiced on a periodic basis. Past-due notices may result in orders being held until the situation is resolved. This credit hold could prevent orders from being placed into production or shipped. Orders not in production that are placed on credit hold for three (3) weeks will be subject to cancellation.

Severe past-due situations may result in the employment of a collection agency or other collection litigation. If any collection activity is necessary regarding a dealer account, the dealer will be responsible for the payment of any and all attorney and collection agency fees.

A slow payment history may result in reducing or eliminating an open line of credit. At the discretion of Bernhardt Design, amounts owed by a dealer to Bernhardt Design arising from any transaction or dealings between the dealer and Bernhardt Design may be offset against any amounts owed to the dealer by Bernhardt Design.

Warranty

Bernhardt Design will repair or replace, at its discretion, any product or part thereof which fails as the result of defects in material and workmanship, under single shift use and normal care for five years from date of shipment. This warranty shall apply only to the original purchaser.

This warranty does not cover normal wear and tear, misuse or abuse of product, dramatic temperature changes, exposure to unusual conditions or damages incurred by contact with seating products, tables, desks or other surfaces. Natural color changes, variations or movements in lumber or veneer products, exposure to extreme temperature changes and direct sunlight may cause color changes and/or surface damage. These are circumstances beyond the control of Bernhardt Design and are not warranty issues. Repair or replacement of discontinued product will be at the discretion of Bernhardt Design.

This warranty is the customer's exclusive remedy for product defect and does not apply to damage caused by a freight carrier, dealer, installer, user modification, attachments to a product, or any third party. Bernhardt Design has the exclusive right to make the final determination of product misuse or abuse. Except as stated above, Bernhardt Design makes no express or implied warranties as to any product, and in particular, makes no warranty of merchantability or of fitness for any particular purpose. Bernhardt Design shall not be liable for any consequential or incidental damages or for commercial loss arising from any product defect.

Operational Parts Warranty

Drawer glides, drawer boxes, drawer pulls, and lock mechanisms have a Life-Time Warranty for original purchaser. Power and communication components are warranted for one year.

Parts Order

Bernhardt Design parts have a \$25 net minimum per order. This does not include freight costs.

Custom Design

Bernhardt Design may alter products to meet specific needs. Contact your local sales representative when a custom design is needed. Custom designs,

if approved, require minimum quantities, additional leadtime and upcharges. A custom job number, available from your Bernhardt Design sales representative, must be submitted with purchase orders.

Orders combining custom design with standard product cannot be scheduled for production until custom items are approved. Custom design orders are not subject to revision or cancellation after acknowledgment.

Wood Finishes

Bernhardt Design tables are available in finishes that are compatible with credenzas and seating finishes. However, finishes on tables may vary slightly from those on seating due to the natural characteristics of the wood. No absolute match is implied or guaranteed.

Light Finishes

Bernhardt Design offers lighter finishes on certain veneers and solid woods. When specifying light finishes the natural characteristics of the wood will be visible and color will vary.

Natural characteristics include the natural discolorations of the wood substance and color variations in glued up stock. These natural characteristics are not considered defects by Bernhardt Design, and therefore merchandise will not be replaced.

Special Finishes

Special finishes, made to customer specifications and subject to factory approval, may be available at a **10% net upcharge with a \$500 net minimum**.

Additional leadtime may be required for special finish items. Special finish orders will not be acknowledged until the special finish sample is approved in writing and received by Bernhardt Design Customer Service. Special finish orders are not subject to revision or cancellation after acknowledgment.

Installation and Maintenance

All freestanding tables and credenzas are equipped with leveling devices. Local floor conditions vary, and it is always necessary to properly adjust leveling devices. Proper leveling is essential to the alignment and function of doors and drawers.

Improperly leveled units result in misaligned doors and drawers and may impair locking mechanisms or other functional hardware.

After the initial installation of credenzas, it may be necessary to readjust and align the units to compensate for settling. This should be expected as a matter of routine maintenance and follow-up to assure proper case function.

Proper installation of Bernhardt Design tables and credenzas is the responsibility of the dealer. Improperly installed units can result in permanent damage to case components. Damage due to improperly installed furniture not covered under product warranty.

Orders combining custom design with standard product cannot be scheduled for production until custom items are approved. Custom design orders are not subject to revision or cancellation after acknowledgment.

Care and Cleaning

Finished wood surfaces should be cleaned with a soft damp cloth, wiping in the direction of the grain. Furniture should be buffed dry immediately with a soft cloth.

Design and Patent Rights

All of the products shown in Bernhardt Design catalogs and described in Bernhardt Design price lists are, and remain, the property of Bernhardt Design, with the sole right reserved to manufacture and to distribute.

Some of the product designs shown are patented in the United States and will remain the property of Bernhardt Design. Any reproduction of the products constitutes an infringement of patented copyright laws and will be subject to prosecution.

Environmental

Some tables and credenzas are LEVEL® for ANSI/BIFMA e3-2019 – Furniture Sustainability Standard and SCS Indoor Advantage™ Gold certified. Visit the product page at bernhardtdesign.com for certifications.

Preferred Carrier Guaranteed Freight Rates - Canada

Freight charges will be applied to orders as a separate line item based on the zones listed. Rates are based on zones with a minimum for each zone.

The freight amount is calculated on the total merchandise list COM price. Additional freight fuel surcharges may apply. Rates are based on deliveries made Monday through Friday, 8 am until 5 pm.

All orders are shipped by Bernhardt Design company trucks or preferred carriers specified by Bernhardt Design. If a purchase order does not specify that the product must ship complete, Bernhardt Design reserves the right to select the most effective shipping method necessary, including split shipments. Dealer warehouse information, including phone number and contact name, must be specified on the purchase order.

Direct site deliveries may be requested with an additional freight cost. Requests for direct site deliveries must be made 2 weeks prior to the scheduled ship week and meet the following criteria:

- Minimum of half truckload
- Delivery site accessible by a 53' trailer
- Complete delivery site address with contact name and on-site phone number
- Labor available for unloading

Deliveries that do not meet the criteria must be directed to a receiver warehouse. If a receiver warehouse is not available, the dealer may make arrangements with their own 3rd party carrier. If a 3rd party carrier is elected, a contact name, phone number and e-mail address is required.

Bernhardt Design has a no touch freight policy. Drivers are not allowed to unload freight.

Weekend direct site deliveries will incur a \$500 per trailer weekend delivery fee. Weekend is defined as between 5 pm Friday and 8 am Monday.

Customers who decline GFP should refer to the shipping section of the Terms and Conditions page.

Zone	Minimums	Freight	Avg. Bus. Days
Zone 1	\$200	5%	10-15
Zone 2	\$200	9%	10-15
Zone 3	\$200	8%	10-15
Zone 4	\$200	11%	10-15
Zone 5	Quote	Quote	

The attached rates are strictly freight and do not include brokerage fees.

