

intersection price list

april 2025



index	2	power + accessories	
laminate selections	3	triad surface mount	
veneer selections	4-5	power overview + grommet placement kits	28
solid surface selections	6	surface mount	
powder coat finishes	7	power overview + grommet placement kits	29-32
collection overview	8	under mount	
tops	9	power overview	33
bases	10	grommet placement kits	34-36
accessories	11	mediatrac 1™	
power	12	power overview	37
ganging brackets + wire management	13	grommet placement kits:	38
training tables	14	extron® AAP modules	39-40
tables		terms and conditions	41-43
square tables - stationary	16	guaranteed freight	44
square table - mobile	17	guaranteed freight - canada	45
rectangular tables - stationary	18-19		
rectangular - mobile	20-21		
modesty panels	22		
upholstery dividers	23-24		
wire management + accessories	25-26		

Laminate Selections

A three character sku identifies each laminate selection as well as the standard finish offered. Individual components are priced with standard finish on standard laminate.

A variety of Wilsonart® standard laminates with standard finishes is offered on conference and multipurpose tables. Additional colors may be available but are

subject to upcharges and extended lead times. The laminate option is available on components where noted as an option in the material specification code.

All laminate tops will have a 3mm matching edge band.

PLL Solid Laminate

Standard Solid

- 671 Designer White, Wilsonart D354-60 Matte Finish
- 672 Frosty White, Wilsonart 1573-60 Matte Finish
- 673 Fashion Grey, Wilsonart D381-60 Matte Finish
- 674 North Sea, Wilsonart D90-60 Matte Finish
- 675 Black, Wilsonart 1595-60 Matte Finish

20% Upcharge

- 665 Snow White Velvet, Wilsonart 15501-31 Traceless Laminate
- 666 Charcoal Velvet, Wilsonart 15504-31 Traceless Laminate
- 667 Black Velvet, Wilsonart 15505-31 Traceless Laminate

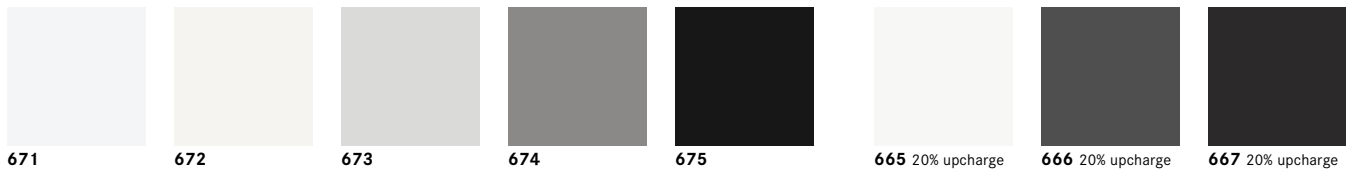

WGL Woodgrain Laminate

Standard Woodgrain

- 684 Phantom Pearl, Wilsonart 8211K-28 Gloss Line Finish w/Aeon Scratch Resistant Protection
- 685 Raw Chestnut, Wilsonart 7975K-12 Soft Grain Finish w/Aeon Scratch Resistant Protection
- 686 High Line, Wilsonart 7970K-18 Linearity Finish w/Aeon Scratch Resistant Protection
- 678 New Age Oak, Wilsonart 7938-16 Casual Rustic Finish
- 679 Brazilwood, Wilsonart 7946-38 Matte Finish
- 687 Boardwalk Oak, Wilsonart 7983-38 Fine Velvet Finish
- 683 Portico Teak (Grey), Wilsonart 8210K-28 Gloss Line Finish
- 681 Studio Teak, Wilsonart 7960-16 Casual Rustic Finish
- 680 Walnut Heights, Wilsonart 7965K-12 Soft Grain Finish
- 682 Asian Night, Wilsonart 7949-16 Casual Rustic Finish



Veneer Selections

A three character sku identifies each species as well as the standard finish offered. Individual components are priced with standard finish. Special finishes on veneers made to customer specifications are subject to factory approval and a 10% net upcharge with a \$500 net minimum.

Transparent stains and sealers are applied in multiple steps to enhance the beauty of the natural wood. A durable, baked-on, top-coat of conversion varnish

or UV topcoat is applied to protect the product. It is recommended that felt, cork or fabric backed desk pads and accessories are used on worksurfaces to minimize wear.

When specifying light finishes the natural characteristics of the wood will be visible and color will vary. Paint finishes are available as custom orders. See terms and conditions for additional finish information.

MPL Maple
Flat Cut

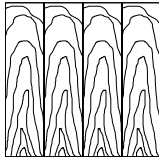

- Standard Finish
 871 860 861
 837 836 823
 865 805 866
 872 839 845
 870

OAK Oak
Rift Cut

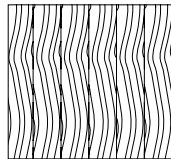

- Standard Finish
 871 870 839
 837 860 861
 865 836 866
 872 805 845

- OAK** Select Finishes
 M73 M72 M75
 M74 M76 M77
 M71

PLD Paldao
Quarter Cut

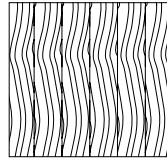

- Standard Finish
 871 860 823
 872 861 866
 870 839

WLT Walnut
Flat Cut

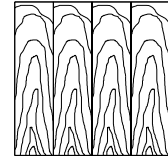

- Standard Finish
 872 861
 870 823
 860 866
 839

MPL Maple



Veneer Selections

OAK Oak



OAK Select Finishes



PLD Paldao

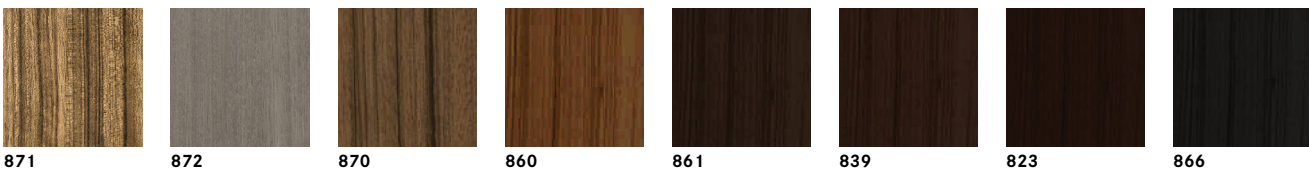

WLT Walnut



Solid Surface Selections

PHL Phenolic

STW Designer White, Wilsonart 15512 SOLICOR, D354-60 Matte Finish

TCB Calcutta Blanc, Wilsonart TS501 THINSCAPE

STB Black Velvet, Wilsonart 15505 Compact Traceless

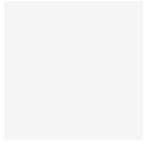

STW

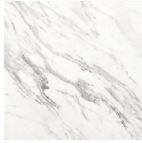

TCB



STB

Powder Coat Selections

A two character sku identifies each powder coat finish offered. Individual skus are priced with standard metal finish. Non-standard finishes may incur an additional charge. All Intersection metal components are only offered in powder coat finishes.

Powder Coat Finishes

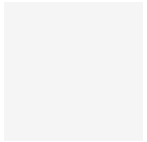

WH Satin White



AL Matte Aluminum

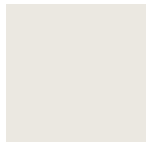

EC Ecreu

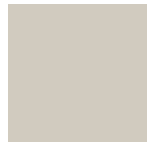

LA Latte

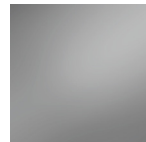

GR Graphite

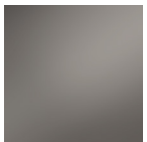

BZ Bronze



SG Sage



IG Iron Grey



RD Black Red

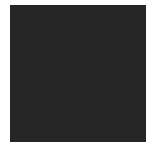

BK Matte Black

Optional Powder Coat Colors - RAL

- Lead Time - Three weeks additional lead-time after color approval
- Net Up-charge - \$1000 for colors shown in Bernhardt Design RAL Powder Coat Selector
- Minimum Order Quantity - None
- Approval Sample Cost - None
- Combining Products - One up-charge is applicable for multiple products on a single purchase order when they are in the same color

Intersection Table Collection

The Intersection table collection bridges that gap between training and meeting tables by offering both styles of tables within the same collection. Mobile and stationary options are available and allow for flexibility within small, large or open office environments. Privacy panels and divider screens provide visual privacy so even in the largest workspaces, individuals can maintain their own space while working.



Training Tables - Ranging from 24"-36" wide by 48"-90" long. Tables are available in both fixed and mobile versions.



Mobile Tables - Ranging from 24"-48" wide by 48"-90" long



Meeting Tables - Ranging from 36"-54" wide by 60"-120" long



Touchdown Tables - Ranging from 48"-84" wide by 48"-90"



Square Work/Cafe Tables - Available in 36", 42", 48" and 54" square

Intersection Tops



Intersection offers a selection of different table edges depending on the top material chosen. Specify the selected edge codes associated with the top material when ordering.



Laminate

- PLL Solid Laminate
- WGL Woodgrain Laminate

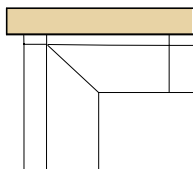

F1 3/4" Flat



Veneer

- MPL Maple
- PLD Paldao
- OAK Oak
- WLT Walnut

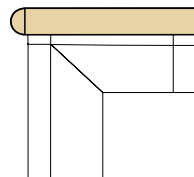

BL 3/4" Bullnose



Solid Surface

- PHL Phenolic

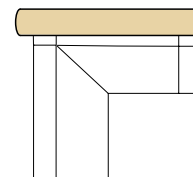

B2 1/2" Arched

specification codes example: INS-SKU-N1U1

series	sku	power access location
intersection		R01 triad surface mount power - see pg 28 surface mount - see pg 29-32 under mount power - see pg 33-36 mediatrac™ - see pg 37-38 000 none
I N S -	-	

material + finish code example: WH PLL 805

base finish	top material	top finish
WH satin white powder coat EC ecru powder coat LA latte powder coat AL matte aluminum powder coat GR graphite powder coat BZ bronze powder coat IG iron grey powder coat SG sage powder coat RD black red powder coat BK matte black powder coat	PLL solid laminate WGL woodgrain laminate MPL maple OAK oak WLT walnut PLD paldao PHL phenolic	see pages 4-6

Intersection Table Bases



The intersection meeting table features extruded aluminum legs and structural rails. The table is available in two configurations: mobile and stationary. A wide range of powder coat finishes are available for the table bases. Bases and tops are sold as a complete assembly. Tops are available in 24", 36", 30", 42", 48" and 54" widths.

Intersection tables are SCS Indoor Advantage™ Gold and LEVEL 2 certified.

Mobile overview

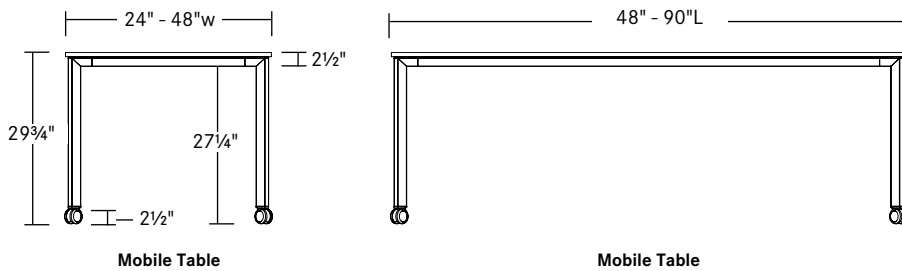

Stationary overview

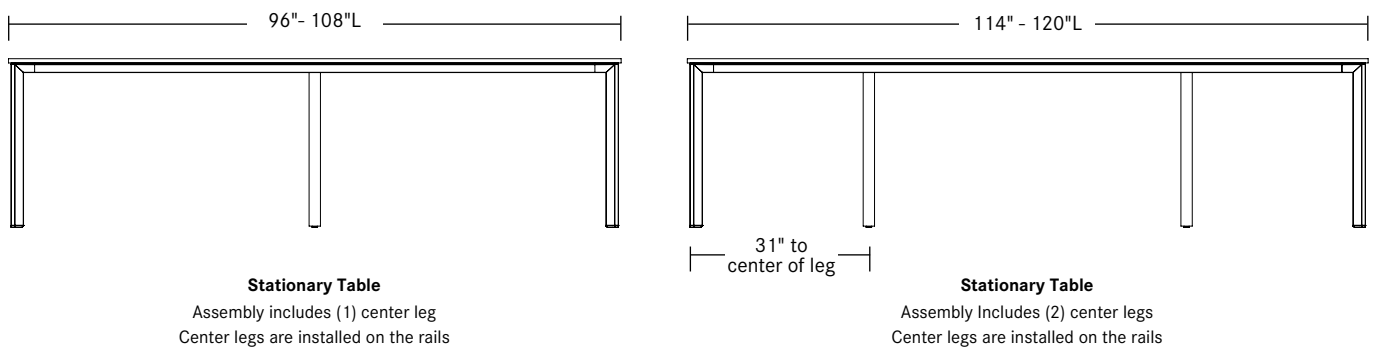
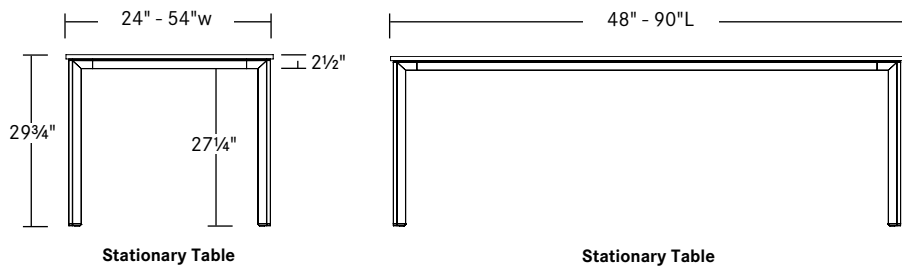

Intersection Divider Screen



The Intersection divider screen is a new and casual way to address the privacy and spacial separation in active work environments. The divider screen is available in 6 different lengths. It features an aluminum base that is available in all standard powder coat finishes. Specify the divider screen separately.

A complete list of recommended Bernhardt Textiles will be displayed on the Intersection product page on BernhardtDesign.com.

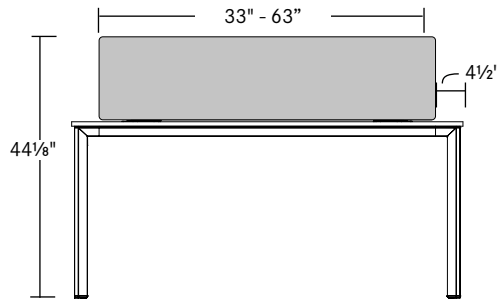

Front View
Showing Divider Screen

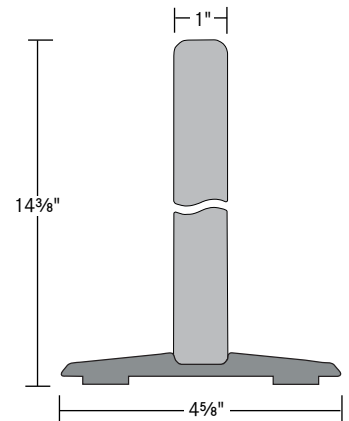

Detail End View
Showing Divider Screen

Divider Screen	Use with Table
33"	42"
39"	48"
45"	54"
51"	60"
57"	66"
63"	72"

Intersection Modesty Panel



Intersection tables are available with an aluminum modesty panel. It is mounted on the inside of the rail, keeping the exterior clean. The modesty panel is available in six lengths and in all standard powder coat finishes. Specify the modesty panel separately.

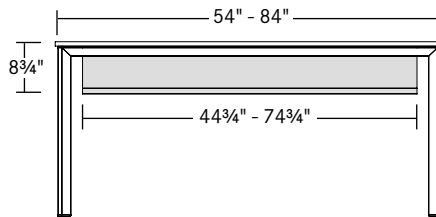

Front View
Showing Modesty Panel
Not available on Phenolic tops

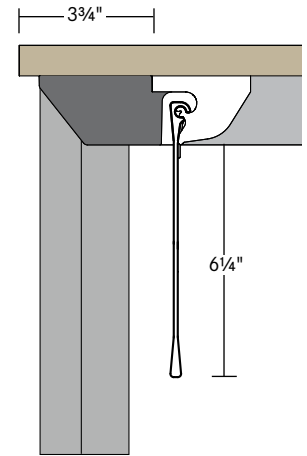

Detail Section View
Showing Modesty Panel

Modesty Panel	Use with Table
44 3/4"	54"
50 3/4"	60"
56 3/4"	66"
62 3/4"	72"
68 3/4"	78"
74 3/4"	84"

Intersection Bag Hook



The bag hook is available in standard powder coat colors. Specify the bag hook separately.

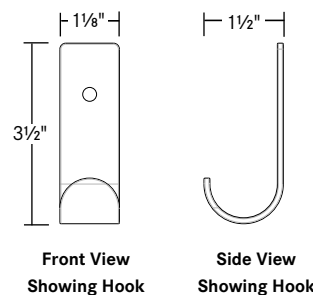

Front View
Showing Hook

Side View
Showing Hook

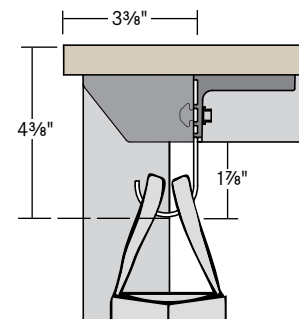

The Intersection bag hook is mounted inside the rails and will support 10 lbs.

Power



Intersection meeting and training tables offer a selection of power options to meet the needs of each individual work environment. Triad, under mount and mediatrac 1™ power are available for all square mobile and stationary tables. Rectangle tables offer under mount, surface mount and mediatract power options for mobile and stationary tables. If ganging Intersection training tables, under mount and surface mount power can be specified allowing power to multiple tables.

**Triad Power**

(3) Receptacles, (3) USB 2 Type-A ports and (3) USB 3 Type-C ports.

**Under Mount Power**

(1) Grounded receptacle and (1) USB 2 Type-A port and (1) USB 3 Type-C port available as single corded or in multiples.

**Surface Mount Power**

(2) Grounded receptacles with (1) USB 2 Type-A port and (1) USB 3 Type-C port

**Mediatrix**

(4) Grounded receptacles with open positions for (4) AAP plates.

Ganging Brackets

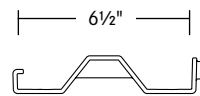
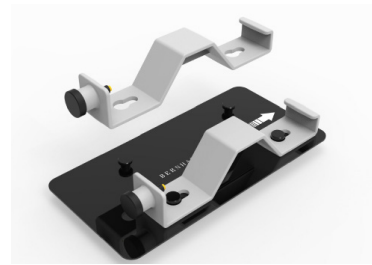
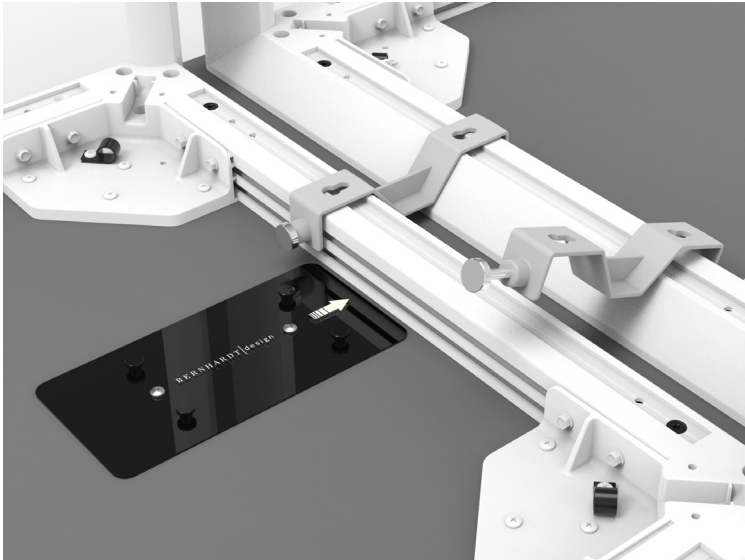

Ganging Brackets

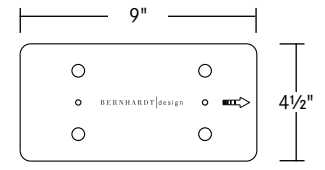

Ganging Bracket Mounting Plate

Intersection features a unique ganging bracket that is sold separately and can easily be field installed. The ganging brackets can be used on any fixed or mobile tables to neatly arrange any configurations. **Note: Due to UL regulations ganging brackets must be used when power is daisy chained.**

Wire Management

Cable Shield



Organizing cables to floor or wall mounted receptacles is clean and easy utilizing the Intersection cable shield. Designed to attach to any Intersection table leg, the cable shield allows a location for wires to be channeled through eliminating the look of messy, loose cords. The shield is powder coated and is available in all standard powder coat colors. **One cable shield comes with each table.**

Wire Management Snake



The wire management snake provides the solution for vertical power management underneath the table. Cables are fed through the top of the snake to the floor allowing the user to plug into floor receptacles or other cables. A top mounting plate and foot is included for ease of installation. Available in black or silver finish.

Training Tables Overview

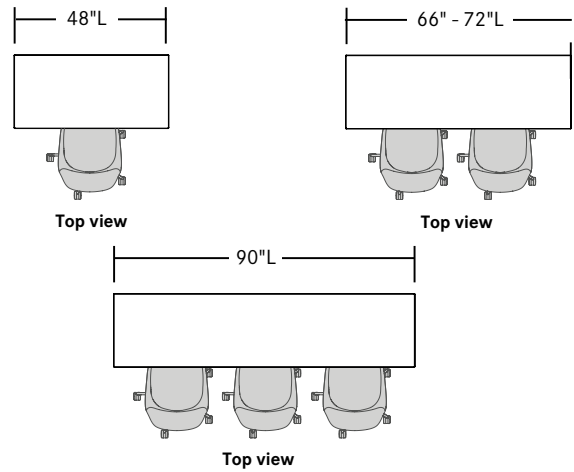

The Intersection collection offers training solutions for (1), (2) and (3) persons.

Configuration and Power Overview

The configurations below illustrate the number of receptacles in a particular work configuration. The set-ups shown below are only some of the many configurations possible. Every situation is unique and should be assessed appropriately.

Surface Mount Power

Large Conference

Conference table set up with (8) tables with single under mount power units, totaling (8) receptacles.

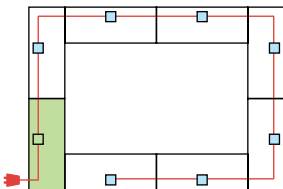

Dual Under Mount Power

Large Conference

Conference table set up with (8) tables with dual under mount power units, totaling (16) receptacles.

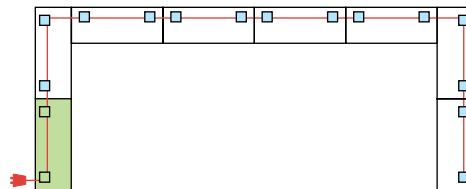

Classroom Seating

Classroom set up examples with single surface mount power units. Power units can be configured for up to (8) receptacles per row.

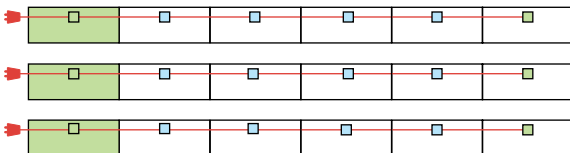

Classroom Seating

Classroom set up with (5) tables with dual under mount power units, totaling (10) receptacles.

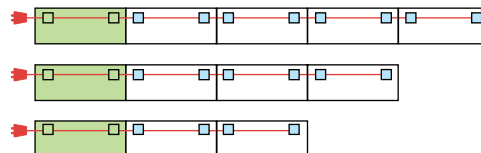



tables

square stationary tables

divider screens are available for 42"-54" length tables
specify divider screen separately
modesty panels cannot be mounted to phenolic tops



	sku	l	w	h	PLL solid laminate	MPL maple	PLD paldao	PHL phenolic
					WGL woodgrain laminate	OAK oak	WLT walnut	BL
					F1	BL	BL	B2
square stationary tables	FAA	36	36	29¾	\$ 2915	\$ 3551	\$ 4120	\$ 4929
	FBB	42	42	29¾	3233	3684	4274	6572
	FCC	48	48	29¾	3297	3816	4427	7049
	FDD	54	54	29¾	3922	4028	4673	7579



specification codes example: INS-SKU-N1U1

series	sku	power access location
intersection		R01 triad surface mount power - see pg 28 under mount power - see pg 33-36 mediatrac™ - see pg 37-38 000 none
I N S -	-	

material + finish code example: WH OAK 805

base finish	top material	top finish
WH satin white powder coat EC ecru powder coat LA latte powder coat AL matte aluminum powder coat GR graphite powder coat BZ bronze powder coat IG iron grey powder coat SG sage powder coat RD black red powder coat BK matte black powder coat	PLL solid laminate WGL woodgrain laminate MPL maple OAK oak WLT walnut PLD paldao PHL phenolic	see pages 4-6

square mobile tables



divider screens are available for 42"-54" length tables
specify divider screen separately
(2) free and (2) locking casters included
white casters will ship with white powder coat tables
all other powder coat tables will have black casters
modesty panels cannot be mounted to phenolic tops

square mobile tables



sku	l	w	h	PLL solid laminate	MPL maple	PLD paldao	PHL phenolic
				WGL woodgrain laminate	OAK oak		
				F1	BL	BL	B2
MAA	36	36	29¾	\$ 3048	\$ 3684	\$ 4274	\$ 5062
MBB	42	42	29¾	3366	3816	4427	6705
MCC	48	48	29¾	3430	3949	4581	7182
MDD	54	54	29¾	4055	4161	4827	7712

specification codes example: INS-SKU-N1U1

series	sku	power access location
intersection		R01 triad surface mount power - see pg 28 under mount power - see pg 33-36 mediatrac™ - see pg 37-38 000 none
I N S -	-	

material + finish code example: WH OAK 805

base finish	top material	top finish
WH satin white powder coat EC ecru powder coat LA latte powder coat AL matte aluminum powder coat GR graphite powder coat BZ bronze powder coat IG iron grey powder coat SG sage powder coat RD black red powder coat BK matte black powder coat	PLL solid laminate WGL woodgrain laminate MPL maple OAK oak WLT walnut PLD paldao PHL phenolic	see pages 4-6

rectangular stationary tables



modesty panels are available for 54" - 84" length tables
divider screens are available for 48" - 72" length tables
specify modesty panel and divider screen separately
modesty panels cannot be mounted to phenolic tops

	sku	l	w	h	specifications	PLL solid laminate	MPL maple		
						WGL woodgrain laminate	OAK oak	PLD paldao	PHL phenolic
						F1	BL	BL	B2
rectangular stationary tables	FVC	48	24	29¾		\$ 2597	\$ 3551	\$ 4120	\$ 4307
	FVD	54	24	29¾		2703	3604	4181	4746
	FVE	60	24	29¾		2756	3657	4243	4938
	FVF	66	24	29¾		2809	3710	4304	5377
	FVG	72	24	29¾		2862	3763	4366	5514
	FVH	78	24	29¾		2915	3816	4427	6913
	FVI	84	24	29¾		2968	3869	4489	7049
	FVJ	90	24	29¾		3021	3922	4550	7187
	FOD	54	30	29¾		2809	3657	4243	5075
	FOE	60	30	29¾		2862	3710	4304	5267
	FOF	66	30	29¾		2915	3763	4366	5761
	FOG	72	30	29¾		2968	3816	4427	5925
	FOH	78	30	29¾		3021	3869	4489	7352
	FOI	84	30	29¾		3074	3922	4550	7516
	FOJ	90	30	29¾		3127	3975	4611	7680
	FAE	60	36	29¾		3021	3869	4489	5925
	FAF	66	36	29¾		3074	3922	4550	6501
	FAG	72	36	29¾		3445	3975	4611	6693
	FAH	78	36	29¾		3498	4293	4980	8558
	FAI	84	36	29¾		3657	4399	5103	8860
	FAJ	90	36	29¾		3710	4505	5226	8997
	FAK	96	36	29¾	one center leg	3763	4664	5411	9162
	FAL	102	36	29¾	one center leg	4134	4770	5534	9518
	FAM	108	36	29¾	one center leg	4240	4876	5657	9710

specification codes example: INS-SKU-N1U1

series	sku	power access location
intersection		<p>surface mount - see pg 29-32</p> <p>under mount power - see pg 33-36</p> <p>mediatrac™ - see pg 37-38</p> <p>000 none</p>
I N S -	-	

material + finish code example: WH OAK 805

base finish	top material	top finish
<p>WH satin white powder coat</p> <p>EC ecru powder coat</p> <p>LA latte powder coat</p> <p>AL matte aluminum powder coat</p> <p>GR graphite powder coat</p> <p>BZ bronze powder coat</p> <p>IG iron grey powder coat</p> <p>SG sage powder coat</p> <p>RD black red powder coat</p> <p>BK matte black powder coat</p>	<p>PLL solid laminate</p> <p>WGL woodgrain laminate</p> <p>MPL maple</p> <p>OAK oak</p> <p>WLT walnut</p> <p>PLD paldao</p> <p>PHL phenolic</p>	see pages 4-6

rectangular stationary tables



modesty panels are available for 54"-84" length tables
divider screens are available for 48"-72" length tables
specify modesty panel and divider screen separately
modesty panels cannot be mounted to phenolic tops

	sku	l	w	h	specifications	PLL solid laminate	MPL maple	PLD paldao	PHL phenolic
						WGL woodgrain laminate	OAK oak		WLT walnut
						F1	BL	BL	B2
rectangular stationary tables	FBE	60	42	29¾		\$ 3180	\$ 4002	\$ 4643	\$ 7516
	FBF	66	42	29¾		3339	4214	4889	8394
	FBG	72	42	29¾		3445	4293	4980	8613
	FBH	78	42	29¾		3763	4611	5349	11566
	FBI	84	42	29¾		3922	4664	5411	11877
	FBJ	90	42	29¾		4081	4770	5534	13166
	FBK	96	42	29¾	one center leg	4187	4876	5657	13385
	FBL	102	42	29¾	one center leg	5035	4929	5718	13879
	FBM	108	42	29¾	one center leg	5141	4982	5780	14126
	FBN	114	42	29¾	two center legs	5247	5300	6148	14510
	FBO	120	42	29¾	two center legs	5353	5512	6394	14757
	FCE	60	48	29¾		3286	4267	4950	7846
	FCF	66	48	29¾		3445	4373	5073	8777
	FCG	72	48	29¾		3551	4611	5349	9190
	FCH	78	48	29¾		3869	4717	5472	12069
	FCI	84	48	29¾		4028	4823	5595	12343
	FCJ	90	48	29¾		4187	4929	5718	12673
	FCK	96	48	29¾	one center leg	4293	5009	5811	12920
	FCL	102	48	29¾	one center leg	5141	5115	5934	13166
	FCM	108	48	29¾	one center leg	5247	5221	6057	13413
	FCN	114	48	29¾	two center legs	5406	5539	6426	15196
	FCO	120	48	29¾	two center legs	5565	5751	6672	15470
	FDG	72	54	29¾		3710	4770	5534	8777
	FDH	78	54	29¾		4028	4876	5657	12398
	FDI	84	54	29¾		4187	4982	5780	12810
	FDJ	90	54	29¾		4346	5141	5964	13139
	FDK	96	54	29¾	one center leg	4452	5300	6148	13440
	FDL	102	54	29¾	one center leg	5300	5512	6394	13715
	FDM	108	54	29¾	one center leg	5459	5724	6640	14043
	FDN	114	54	29¾	two center legs	5618	6095	7071	15909
	FDO	120	54	29¾	two center legs	5777	6307	7317	16184

specification codes example: INS-SKU-N1U1

series	sku	power access location
intersection		surface mount - see pg 29-32
		under mount power - see pg 33-36
		mediatrac™ - see pg 37-38
		000 none
I N S -	-	

material + finish code example: WH OAK 805

base finish	top material	top finish
WH satin white powder coat	PLL solid laminate	see pages 4-6
EC ecru powder coat	WGL woodgrain laminate	
LA latte powder coat	MPL maple	
AL matte aluminum powder coat	OAK oak	
GR graphite powder coat	WLT walnut	
BZ bronze powder coat	PLD paldao	
IG iron grey powder coat	PHL phenolic	
SG sage powder coat		
RD black red powder coat		
BK matte black powder coat		

rectangular mobile tables



modesty panels are available for 54"-84" length tables
divider screens are available for 48"-72" length tables
specify modesty panel and divider screen separately
(2) free and (2) locking casters included
white casters will ship with white powder coat tables
all other powder coat tables will have black casters

	sku	l	w	h	PLL solid laminate	MPL maple	PLD paldao	PHL phenolic
					WGL woodgrain laminate	OAK oak	WLT walnut	BL
					F1	BL	BL	B2
rectangular mobile tables	MVC	48	24	29¾	\$ 2730	\$ 3684	\$ 4274	\$ 4440
	MVD	54	24	29¾	2836	3737	4335	4879
	MVE	60	24	29¾	2889	3790	4397	5070
	MVF	66	24	29¾	2942	3843	4458	5509
	MVG	72	24	29¾	2995	3896	4520	5646
	MVH	78	24	29¾	3048	3949	4581	7045
	MVI	84	24	29¾	3101	4002	4643	7182
	MVJ	90	24	29¾	3154	4055	4704	7320
	MOD	54	30	29¾	2942	3790	4397	5207
	MOE	60	30	29¾	2995	3843	4458	5399
	MOF	66	30	29¾	3048	3896	4520	5893
	MOG	72	30	29¾	3101	3949	4581	6057
	MOH	78	30	29¾	3154	4002	4643	7484
	MOI	84	30	29¾	3207	4055	4704	7648
	MOJ	90	30	29¾	3260	4108	4766	7813
	MAE	60	36	29¾	3154	4002	4643	6057
	MAF	66	36	29¾	3207	4055	4704	6634
	MAG	72	36	29¾	3578	4108	4766	6826
	MAH	78	36	29¾	3631	4426	5135	8690
	MAI	84	36	29¾	3790	4532	5258	8992
MAJ	90	36	29¾	3843	4638	5381	9129	

specification codes example: INS-SKU-N1U1

series	sku	power access location
intersection		surface mount - see pg 29-32 under mount power - see pg 33-36 mediatrac™ - see pg 37-38 000 none
I N S -		

material + finish code example: WH OAK 805

base finish	top material	top finish
WH satin white powder coat EC ecru powder coat LA latte powder coat AL matte aluminum powder coat GR graphite powder coat BZ bronze powder coat IG iron grey powder coat SG sage powder coat RD black red powder coat BK matte black powder coat	PLL solid laminate WGL woodgrain laminate MPL maple OAK oak WLT walnut PLD paldao PHL phenolic	see pages 4-6

rectangular mobile tables



modesty panels are available for 54"-84" length tables
divider screens are available for 48"-72" length tables
specify modesty panel and divider screen separately
(2) free and (2) locking casters included
white casters will ship with white powder coat tables
all other powder coat tables will have black casters

sku	l	w	h	PLL solid laminate	MPL maple	PLD paldao	PHL phenolic	
				WGL woodgrain laminate	OAK oak		WLT walnut	B2
				F1	BL	BL	B2	
rectangular mobile tables	MBE	60	42	29¾	\$ 3313	\$ 4134	\$ 4796	\$ 7648
	MBF	66	42	29¾	3472	4346	5042	8526
	MBG	72	42	29¾	3578	4426	5135	8745
	MBH	78	42	29¾	3896	4744	5504	11699
	MBI	84	42	29¾	4055	4797	5565	12009
	MBJ	90	42	29¾	4214	4903	5688	13298
	MCE	60	48	29¾	3419	4399	5103	7978
	MCF	66	48	29¾	3578	4505	5226	8910
	MCG	72	48	29¾	3684	4744	5504	9322
	MCH	78	48	29¾	4002	4850	5626	12201
	MCI	84	48	29¾	4161	4956	5749	12476
	MCJ	90	48	29¾	4320	5062	5872	13765

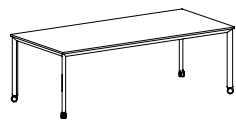

specification codes example: INS-SKU-N1U1

series	sku	power access location
intersection		surface mount - see pg 29-32 under mount power - see pg 33-36 mediatrac™ - see pg 37-38 000 none
I N S -	-	

material + finish code example: WH OAK 805

base finish	top material	top finish
WH satin white powder coat EC ecru powder coat LA latte powder coat AL matte aluminum powder coat GR graphite powder coat BZ bronze powder coat IG iron grey powder coat SG sage powder coat RD black red powder coat BK matte black powder coat	PLL solid laminate WGL woodgrain laminate MPL maple OAK oak WLT walnut PLD paldao PHL phenolic	see pages 4-6



modesty panels

aluminum panel powder coated - specify powder coat finish
 mounting clips included
 modesty panels are shipped separately and field installed
 modesty panels cannot be mounted to phenolic tops

	sku	l	w	h	weight	specifications	price
	MPB	44¾"	¼"	7½"		use with 54" tables	\$ 477
	MPC	50¾"	¼"	7½"		use with 60" tables	504
	MPD	56¾"	¼"	7½"		use with 66" tables	530
	MPE	62¾"	¼"	7½"		use with 72" tables	557
	MPF	68¾"	¼"	7½"		use with 78" tables	583
	MPG	74¾"	¼"	7½"		use with 84" tables	610

specification codes example: INS-SKU

series	sku
intersection	
I N S -	

material + finish code example: BK

finish
WH satin white powder coat
EC ecru powder coat
LA latte powder coat
AL matte aluminum powder coat
GR graphite powder coat
BZ bronze powder coat
IG iron grey powder coat
SG sage powder coat
RD black red powder coat
BK matte black powder coat



divider screen

When specifying textiles visit the Intersection product page on BernhardtDesign.com. In the left-hand column, select graded-in textiles. A complete list of recommended Bernhardt Textiles will be displayed here. Click on the textile of choice and you will be taken to the corresponding textile page on the Bernhardt Design website. Use the four-digit pattern number for the base fabric code shown below and the three-digit colorway number for the base fabric colorway shown below.

Fabric must be railroded. *All COM fabrics must be preapproved by Bernhardt Design prior to application.

SKU	W	D	H	Fabric								
USB - use with 42" tables	33"	4½"	14½"	1.5 yds								
	838 mm	114 mm	368mm	1.4 m								
COM	COL	1	2	3	4	5	6	7	8	9	10	11
458	-	605	632	645	672	698	708	732	752	775	805	922



SKU	W	D	H	Fabric								
USC - use with 48" tables	39"	4½"	14½"	1.75 yds								
	991 mm	114 mm	368mm	1.6 m								
COM	COL	1	2	3	4	5	6	7	8	9	10	11
569	-	741	772	787	818	849	861	888	912	939	974	1110

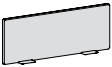

SKU	W	D	H	Fabric								
USD - use with 54" tables	45"	4½"	14½"	2.0 yds								
	1143 mm	114 mm	368mm	1.8 m								
COM	COL	1	2	3	4	5	6	7	8	9	10	11
613	-	809	845	862	898	933	947	978	1005	1036	1076	1231

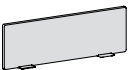

specification codes example: **INS-SKU**

series	sku
intersection	
I N S -	

material + finish code example: **0000-000-BK**

base fabric	base fabric colorway	glide plate finish
see bernhardttextiles.com	see bernhardttextiles.com	WH satin white powder coat
-	-	EC ecru powder coat
		LA latte powder coat
		AL matte aluminum powder coat
		GR graphite powder coat
		BZ bronze powder coat
		IG iron grey powder coat
		SG sage powder coat
		RD black red powder coat
		BK matte black powder coat



divider screen

When specifying textiles visit the Intersection product page on BernhardtDesign.com. In the left-hand column, select graded-in textiles. A complete list of recommended Bernhardt Textiles will be displayed here. Click on the textile of choice and you will be taken to the corresponding textile page on the Bernhardt Design website. Use the four-digit pattern number for the base fabric code shown below and the three-digit colorway number for the base fabric colorway shown below.

Fabric must be railroded. *All COM fabrics must be preapproved by Bernhardt Design prior to application.

SKU	W	D	H	Fabric								
USE - use with 60" tables	51"	4½"	14½"	2.0 yds								
	1295 mm	114 mm	368 mm	1.8 m								
COM	COL	1	2	3	4	5	6	7	8	9	10	11
657	-	853	889	906	942	977	991	1022	1049	1080	1120	1275

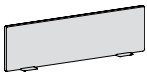

SKU	W	D	H	Fabric								
USF - use with 66" tables	57"	4½"	14½"	2.25 yds								
	1448 mm	114 mm	368 mm	2.1 m								
COM	COL	1	2	3	4	5	6	7	8	9	10	11
701	-	921	961	981	1021	1061	1076	1111	1141	1176	1221	1396

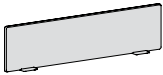

SKU	W	D	H	Fabric								
USG - use with 72" tables	63"	4½"	14½"	2.5 yds								
	1600 mm	114 mm	368 mm	2.3 m								
COM	COL	1	2	3	4	5	6	7	8	9	10	11
745	-	990	1034	1057	1101	1145	1162	1201	1234	1273	1323	1518

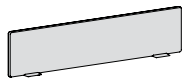



specification codes example: **INS-SKU**

series	sku
intersection	
I N S -	

material + finish code example: **0000-000-BK**

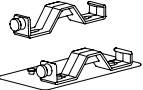
base fabric	base fabric colorway	glide plate finish
see berhardttextiles.com	see berhardttextiles.com	WH satin white powder coat
-	-	EC ecru powder coat
		LA latte powder coat
		AL matte aluminum powder coat
		GR graphite powder coat
		BZ bronze powder coat
		IG iron grey powder coat
		SG sage powder coat
		RD black red powder coat
		BK matte black powder coat



	description	sku	w	d	h	weight	specifications	price
	cable shield for running wire down the leg of the table (1) cable shield is included with every table - painted to match the leg available in all standard powder coat finishes specify powder coat finish	CBS	2½	2¼	6			\$ 83
	ganging brackets molded nylon kit includes (2) brackets for each table available in white finish only	GNG	9	4¾	1½	1		159
	bag hook available in all standard powder coat finishes specify powder coat finish	BPH	1⅞	1½	3½	½		83

specification codes example: INS-SKU

series	sku
intersection	
I N S -	

finish code example: SG

finish
WH satin white powder coat
EC ecru powder coat
LA latte powder coat
AL matte aluminum powder coat
GR graphite powder coat
BZ bronze powder coat
IG iron grey powder coat
SG sage powder coat
RD black red powder coat
BK matte black powder coat

	description	sku	w	d	h	weight	specifications	price
	wire management snake flexible cable management system weighted metal base specify finish code BK (Black) or SV (Silver)	VGW	2½	2½	30			\$ 210
	cable management kit includes (4) cables, p-clip, (4) blocks for securing wires to the table, (1) cable shield comes standard with each table	CBK	5	5	1			83

specification codes example: ACS-SKU

series	sku
A C S -	

finish code example: SV

finish
BK matte black powder coat SV silver



power + accessories

Triad Power Module



The Triad surface mount power module offers a simple and clean way of bringing power and USB to the worksurface.

The Triad surface mount power module installs flush to the worksurface and is offered with (3) receptacles or (3) receptacles, (3) USB-A ports and (3) USB-C ports. Modules are available with a matte black or satin white finish.

When specifying Triad Round Surface Power for table assemblies use R01 grommet kit code.

The power module is UL approved with spill-proof technology and a 15 amp, 10' power infeed. Power module is certified to UL STD 962 A CSA SDT 22.2 No.21.

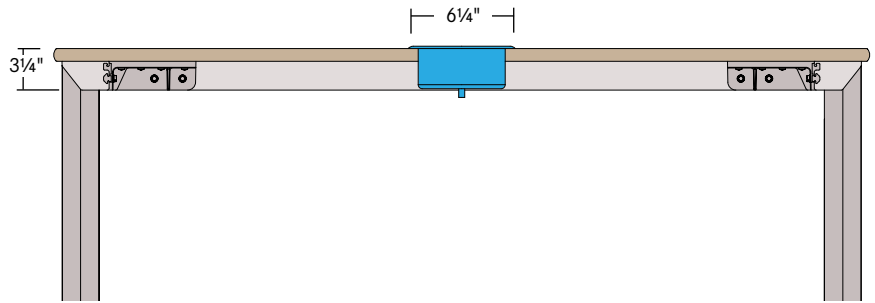

Note: End user installation will be required per individual SKU. Power specified separately.

Triad Power Module- Power + USB

- Updated Information Shown in RED
- Matte Black or Satin White Finish
- (3) 120v 60 Hz. 15 amp Receptacles
- (3) 2 amp USB-A ports, 10 watt
- (3) 2 amp USB-C ports, 20 watt
- 10' cord, 15 amp
- 6 1/4" w x 6 1/4" d x 2 1/2" h
- Specify power style **TPU**

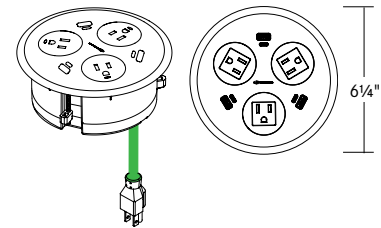

sku descriptions

R01 36" - 54" Square Tables

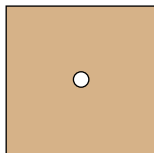

Power Style
TPU
\$ 1993

specification codes example: ACS-R01-TPU

series	sku	power style
accessories		TPU power + usb
A C S -	R 0 1 -	T P U

finish code example: WH

finish
BK matte black
WH satin white

Surface Mount Power Module

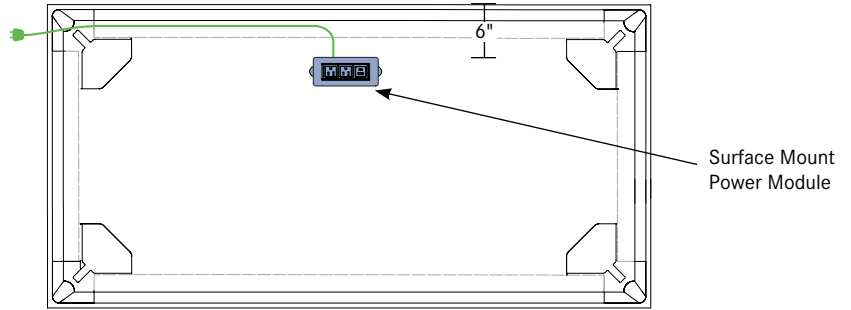

Intersection offers a surface mount power solution allowing quick and power access. A maximum of (10) surface mount power modules can be connected on a single power infeed. See the following pages for grommet location and codes. Surface mount power is certified to UL STD 962 A CSA STD 22.2 No. 21.

Power Module

Black, Silver or White Finish

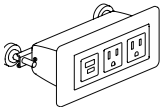

- (2) 120 v 60 Hz. 15 amp receptacles
- (1) 2 amp USB-A port, 10 watt
- (1) 2 amp USB-C port, 20 watt
- 6 1/2" w x 3" d x 2 3/4" h

Jumper

(if required)

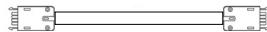

Jumper is determined by the length of the top specified

H-Block Connector

Grey Finish

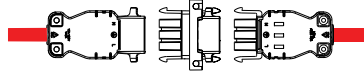

Power Infeed

10' Grounded Plug

Required per individual SKU

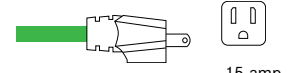

15 amp

Surface Mount grommet kits and locations codes for veneer, laminates and solid surface tops.

Kits include all jumpers and necessary components based on table length and power option. Grommet kits ship separately from tops.

sku	descriptions	price
NRS1	48" - 90" L Tables available on 24"w - 36"w tables	\$ 1323
NLS1	48" - 90" L Tables available on 24"w - 36"w tables	1323

specification codes example: ACS-SKU-CRD-048







series	sku	power option	table
accessories		CRD corded	048 072 054 078 060 084 066 090
A C S -	-		

Important:
Specify the length of the table that your configuration is to go on, this will insure the proper length of wiring is provided in the kit.

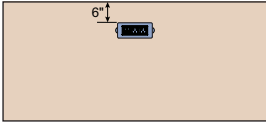
finish code example: WH

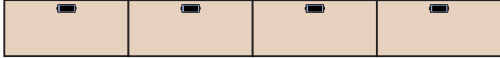
- BK black
- SV silver
- WH white

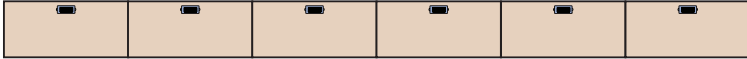
Surface Mount grommet kits and locations codes for veneer, laminates and solid surface tops.
 Kits include all jumpers and necessary components based on table length and power option.
 Grommet kits ship separately from tops.

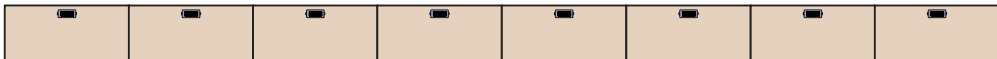
sku	descriptions	specifications	price
N1S1	48" - 84" L Tables available on 24"w - 36"w tables 		\$ 917
N1S2	48" - 84" L Tables 	2 tables daisy chained, specify ganging brackets separately	2257
N1S3	48" - 84" L Tables 	3 tables daisy chained, specify ganging brackets separately	3127
N1S4	48" - 84" L Tables 	4 tables daisy chained, specify ganging brackets separately	3999
N1S5	48" - 72" L Tables 	5 tables daisy chained, specify ganging brackets separately	4868
N1S6	48" - 72" L Tables 	6 tables daisy chained, specify ganging brackets separately	5739
N1S7	48" - 60" L Tables 	7 tables daisy chained, specify ganging brackets separately	6609
N1S8	48" - 60" L Tables 	8 tables daisy chained, specify ganging brackets separately	7480

specification codes example: ACS-SKU-CRD-048





series	sku	power option	table
accessories		CRD corded	048 072 054 078 060 084 066
A C S -	-		

Important:
 Specify the length of the table that your configuration is to go on, this will insure the proper length of wiring is provided in the kit.

finish code example: WH

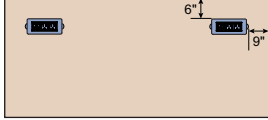
finish
BK black SV silver WH white

Surface Mount grommet kits and locations codes for veneer, laminates and solid surface tops.
Kits include all jumpers and necessary components based on table length and power option.
Grommet kits ship separately from tops.

sku	descriptions	price
N2S1	48" - 90"L Tables available on 24"w - 36"w tables 	\$ 2112
N2S2	48" - 90"L Tables 2 tables daisy chained, specify ganging brackets separately 	3708
N2S3	48" - 90"L Tables 3 tables daisy chained, specify ganging brackets separately 	5304
N2S4	48" - 90"L Tables 4 tables daisy chained, specify ganging brackets separately 	7009
N2S5	48" - 72"L Tables 5 tables daisy chained, specify ganging brackets separately 	8605

specification codes example: ACS-SKU-CRD-048



series	sku	power option	table
accessories		CRD corded	048 072 054 078 060 084 066 090
A C S -	-		

Important:
Specify the length of the table that your configuration is to go on, this will insure the proper length of wiring is provided in the kit.

finish code example: WH

finish
BK black SV silver WH white

Surface Mount grommet kits and locations codes for veneer, laminates and solid surface tops.
 Kits include all jumpers and necessary components based on table length and power option.
 Grommet kits ship separately from tops.

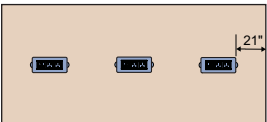
sku	descriptions	price
N1C1	60" - 84"L Tables 114" - 120"L Tables available on 42"w - 54"w tables 	\$ 1323
N2C1	72" - 120"L Tables available on 42"w - 54"w tables 	2257
N3C1	114" - 120" L Tables available on 42"w - 54"w tables no center stretcher 	3017

specification codes example: ACS-SKU-CRD-060

series	sku	power option
accessories		CRD corded
A C S -	-	

table
060 096
066 102
072 108
078 114
084 120
090

Important:
 Specify the length of the table that your configuration is to go on, this will insure the proper length of wiring is provided in the kit.

finish code example: WH

finish
BK black
SV silver
WH white

Under Mount Power



Intersection offers a proprietary under mount power solution allowing quick and easy daisy chaining of modules together. A maximum of (8) under mount power modules can be connected on one power infeed with a run length not to exceed 40'.

End user installation will be required per individual kit. Each kit includes a separate power infeed with a 10' grounded plug to connect to the power source. See installation instructions for installing.

The aluminum housing for the power module is available in all standard powder coat finishes. White receptacles will be provided with white powder coat and black receptacles for all other colors. Under mount power is certified to UL STD 962 A CSA STD 22.2 No. 21.

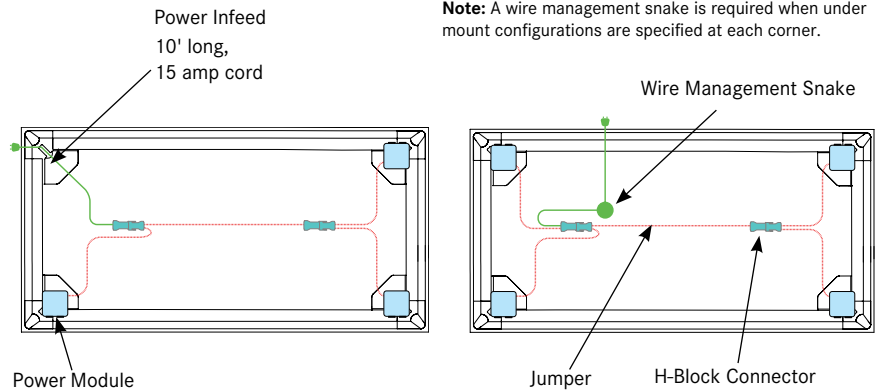

Note: A wire management snake is required when under mount configurations are specified at each corner.

Bernhardt Design provides recommendations for installation locations as shown on the following pages. Further installation instructions are included with each power unit. Power is specified separately.

Power Modules

Powder Coat Must be Specified

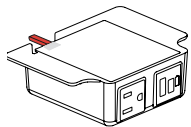

Jumper

(if required)



Jumper is determined by the length of the top specified

H-Block Connector

Grey Finish

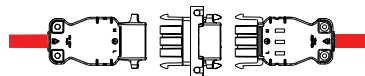

Power Infeed Options

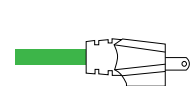

10' Grounded Plug
Required per individual SKU

power + usb-a + usb-c

- (1) 120v 60 Hz. 15 amp Receptacles
- (1) 2 amp USB-A port, 10 watt
- (1) 2 amp USB-C port, 20 watt
- 10' cord
- grounded plug
- UL 962 listed

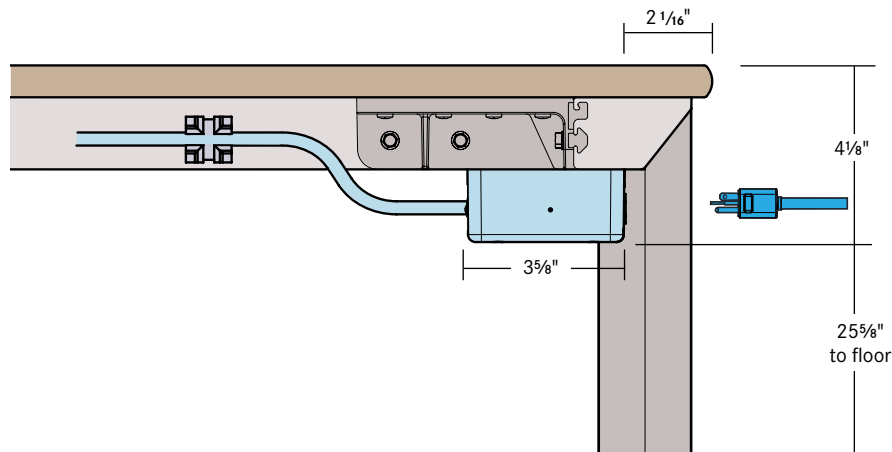

Under Mount Grommet Kits

Under mount power kits are specified and sold separately and can be mounted in any location corner, rail or on the stretcher. Shown below are the examples of the location that under mount power modules can be mounted.

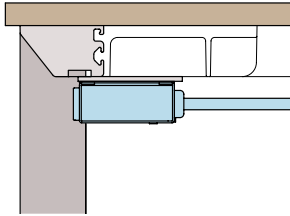

Power Module mounted at the corner

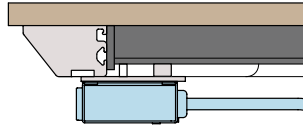

Power Module mounted to stretcher

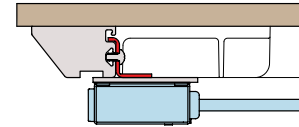

Power Module mounted to rail

Under mount power kits are specified and sold separately. Each kit lists the table top sizes compatible with the number of power units shown.

All kits include a 10' corded infeed with grounded and fused plug.

# of Kits	sku	description	specifications	
1 Module Kit				
	N1U1	36" - 54"L Tables	available on 36"w - 54"w tables can be mounted in any location: corner, rail or stretcher	power + usb + usb-c  \$ 559
	N1U1	60" - 120"L Tables	available on 24"w - 54"w tables can be mounted in any location: corner, rail or stretcher	559

specification codes example: ACS-SKU-048

series	sku	table length
		036 084
		042 090
		048 096
		054 102
		060 108
		066 114
		072 120
		078
A C S -	-	

Important:
Specify the length of the table that your configuration is to go on, this will insure the proper length of wiring is provided in the kit.





finish code example: WH

finishes
WH satin white powder coat
EC ecru powder coat
LA latte powder coat
AL matte aluminum powder coat
GR graphite powder coat
BZ bronze powder coat
IG iron grey powder coat
SG sage powder coat
RD black red powder coat
BK matte black powder coat

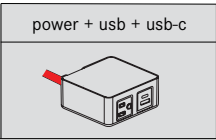
Under mount power kits are specified and sold separately. Each kit lists the table top sizes compatible with the number of power units shown.

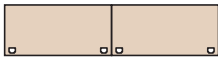
All kits include a 10' corded infeed with grounded and fused plug.

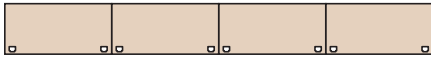

# of Kits	sku	description	specifications
2 Module Kits			
	N2U1	48" - 120" L Tables available on 24"w - 54"w tables	\$ 1685
			
	N2U2	48" - 90" L Tables 2 tables daisy chained, specify ganging brackets separately	2695
			
	N2U3	48" - 90" L Tables 3 tables daisy chained, specify ganging brackets separately	3497
			
	N2U4	48" - 90" L Tables 4 tables daisy chained, specify ganging brackets separately	4432
			
	N2U5	48" - 90" L Tables 5 tables daisy chained, specify ganging brackets separately	5369
			

specification codes example: ACS-SKU-048

series	sku	table length
A	C	S
-	-	-
		048 090
		054 096
		060 102
		066 108
		072 114
		078 120
		084

Important:
Specify the length of the table that your configuration is to go on, this will insure the proper length of wiring is provided in the kit.

finish code example: WH

finishes
WH satin white powder coat
EC ecru powder coat
LA latte powder coat
AL matte aluminum powder coat
GR graphite powder coat
BZ bronze powder coat
IG iron grey powder coat
SG sage powder coat
RD black red powder coat
BK matte black powder coat

Under mount power kits are specified and sold separately. Each kit lists the table top sizes compatible with the number of power units shown.

All kits include a 10' corded infeed with grounded and fused plug.

of Kits sku description

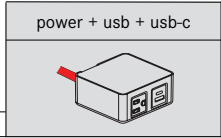

3 Module Kits

N3U1 60" - 120"L Tables

\$ 2345

available on 24"w - 54"w tables

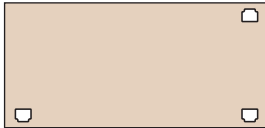

4 Module Kits

N4U1 60" - 120"L Tables

60" - 120"L Tables

2695

available on 24"w - 54"w tables

cable snake required. specify separately

alternate install shown

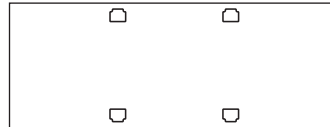
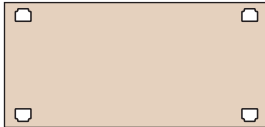

6 Module Kits

N6U1 90" - 120"L Tables

90" - 120"L Tables

3497

available on 24"w - 54"w tables

cable snake required. specify separately

alternate install shown

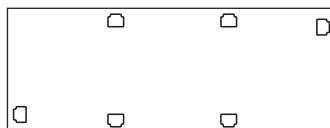
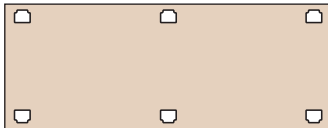

specification codes example: ACS-SKU-060

series	sku	table length
A	C	060 096
C	S	066 102
S	-	072 108
-	-	078 114
-	-	084 120
-	-	090

Important:
Specify the length of the table that your configuration is to go on, this will insure the proper length of wiring is provided in the kit.

finish code example: WH

finishes
WH satin white powder coat
EC ecru powder coat
LA latte powder coat
AL matte aluminum powder coat
GR graphite powder coat
BZ bronze powder coat
IG iron grey powder coat
SG sage powder coat
RD black red powder coat
BK matte black powder coat

Mediatrac 1™

Mediatrac 1™ grommet system is simplified for bringing power and data to the meeting table worksurface in a clean easy way.

Mediatrac 1 grommet system provides power and (16) different Extron data configurations. For Intersection the aluminum trim will be powder coated and you have the option of powder coated, laminate or wood veneer doors. Mediatrac 1 has a corded or hard wired power infeed.

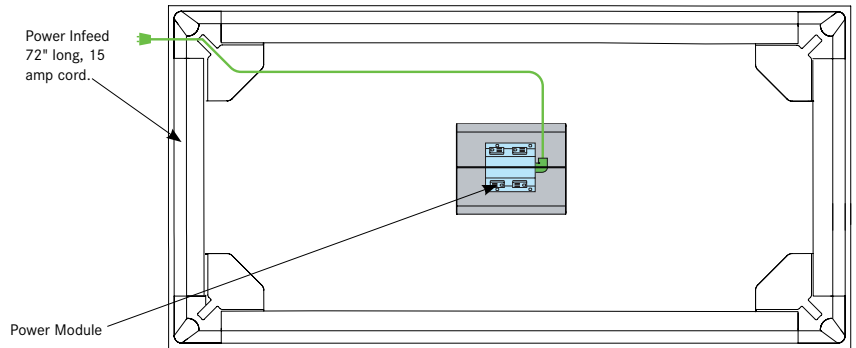

Note: End user installation will be required per individual SKU. Power specified separately. See the following pages for grommet codes.

Mediatrac 1 Grommet Kits (Includes the Following)

Power Module

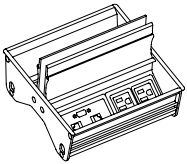

Number and configuration of grommet modules determined by the grommet code

Jumper

(if required)

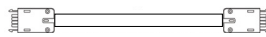

Jumper is determined by the length of the top specified

H-Block Connector

Grev Finish

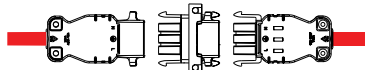

Power Infeed Options

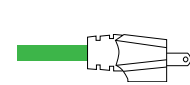

15 amp

10' Grounded Plug
Required per individual SKU



72" 4-Trac Power Infeed with
Hardwired Conduit

Mediatrac 1 Dimensional Specifications

Mediatrac 1™ is offered as a 8" double grommet with (4) receptacles and open positions for (4) AAP plates. Mediatrac 1™ is UL listed.

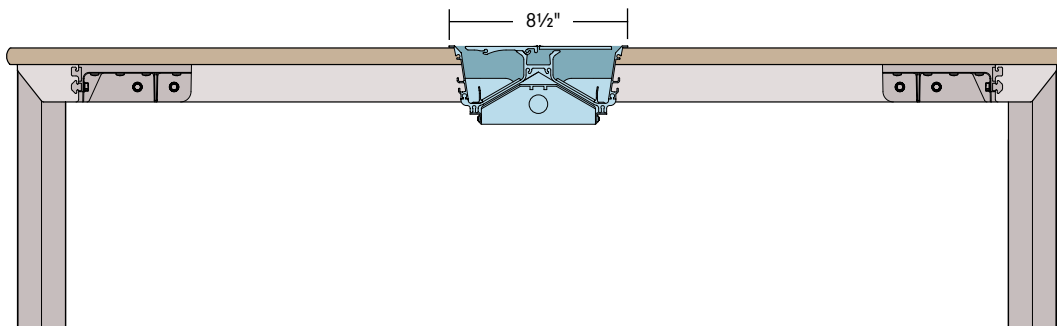



Mediatrac 1 is certified to UL STD 962A, UL STD 1363, CSA STD 22.2 No. 308-14. 4-Trac is certified to UL STD 183 CSA STD 22.2 No. 203.1-14.

Mediatrac 1 grommet kits and locations codes for veneer, laminates and solid surface tops. Kits include all jumpers and necessary components based on table length and power option. Grommet kits ship separately from tops.

Specify table length, power style, lid material and frame finish below.

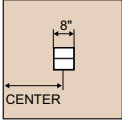
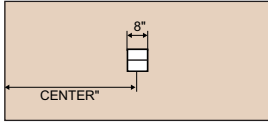
When phenolic is specified for table top, specify aluminum frame material and choose powder coat finish.

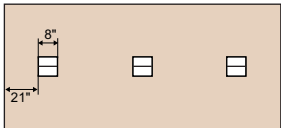



sku	descriptions	lid material		
		ALM aluminum	PLL solid laminates WGL woodgrain laminates	MPL maple OAK oak PLD paldao WLT walnut
I03	36" - 54"L Tables available on 36"w - 54"w tables (1) 8" double door mediatrac grommet 	\$ 2119	\$ 2385	\$ 3313
I03	60" - 84"L Tables 114" - 120"L Tables available on 36"w - 54"w tables (1) 8" double door mediatrac grommet 	2119	2385	3313
I05	90" - 120"L Tables available on 36"w - 54"w tables (2) 8" double door mediatrac grommets 	3842	4105	6357
I10	114" - 120"L Tables available on 42"w - 54"w tables (3) 8" double door mediatrac grommets 	5806	6293	9535

specification codes example: MGS-103-CRD096



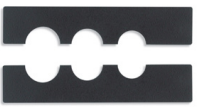



series	sku	power option	table length
top		CRD corded	036 084
		4TH four trac hardwired	042 090
			048 096
			054 102
			060 108
			066 114
			072 120
			078

material + finish code example: WH WLT 870

frame finish	lid material	lid finish
WH satin white powder coat	PLL solid laminate	see pages 3-5
EC ecru powder coat	WGL woodgrain laminate	
LA latte powder coat	MPL maple	
AL matte aluminum powder coat	OAK oak	
GR graphite powder coat	WLT walnut	
BZ bronze powder coat	PLD paldao	
IG iron grey powder coat	ALM aluminum	
SG sage powder coat		
RD black red powder coat		
BK matte black powder coat		

	description	sku	w	d	h	price
	blank plate Extron® AAP blank plate with black powder coat finish single space insert	VGG	3½	-	5⁄8	\$ 171
	cable pass-through module Extron® AAP single space, cable pass-through plates sold as a set of (2) black powder coat finish	VGY	3½	-	1¾	487
	phone/data module Extron® AAP two RJ-45 pass-through barrels CAT 5e single space insert	VGD	3½	-	5⁄8	367
	phone/data module Extron® AAP one RJ-45 female to punch down block leviton CAT6 data single space insert	VGK	3½	-	5⁄8	294
	phone/data module Extron® AAP two RJ-45 female to punch down block leviton CAT6 data single space insert	VGP	3½	-	5⁄8	408
	phone/data module Extron® AAP two RJ-45 female to punch down block AMP CAT6 data single space insert	VGL	3½	-	5⁄8	408

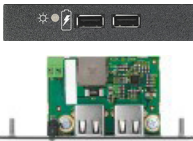
series	sku
accessories	
A C S -	

description	sku	w	d	h	price
 <p>phone/data module</p> <p>Extron® AAP two RJ-45 female to punch down block higher than CAT6 data type connectors systemax MGS500 backward compatible double space insert</p>	VGQ	3½	-	1¾	\$ 555
 <p>computer/audio/video module</p> <p>Extron® AAP HDMI female to HDMI female on 10" pigtail single space insert</p>	VG3	3½	-	5⁄8	408
 <p>control/computer module</p> <p>Extron® AAP two USB A female to female barrels single space insert</p>	VGR	3½	-	5⁄8	408
 <p>power plate charging module</p> <p>type 5 VDC USB C power outlet 3 A/45 watts type 5 VDC USB A power outlet 2.1A/10.5 watts of power for charging mobile devices, single space insert</p>	VG9	3½	-	5⁄8	1395
 <p>usb charging module</p> <p>Extron® AAP Power Plate charging module 2 5 VCD USB power outlets 2.1 A / 10.5 watts of power for charging mobile devices single space insert</p>	VGU	3½	-	5⁄8	791
 <p>computer/audio/video module</p> <p>Extron® SuperPlate 110 - HDMI/DisplayPort/Stereo Audio/USB HDMI: female to female, 10" (25 cm) pigtail DisplayPort: female to female, 10" (25 cm) pigtail Stereo/Audio: 3.5 mm mini jack to captive screw, 10" (25 cm) pigtail USB A: female to female, 10" (25 cm) pigtail double space insert</p>	VG6	3½	-	1¾	647

series	sku
accessories	
A C S -	

Prices and Specifications

Prices and specifications are subject to change without notice. All prices quoted will be FOB our factories. If applicable, sales tax will be based on ship-to destination.

Bernhardt Design reserves the right to make changes in dimensions, construction, price lists, or product literature without prior notice.

All measurements and weights are approximate and subject to change without notice.

Order Entry

All orders are subject to final acceptance by Bernhardt Design in Lenoir, NC. Receipt of our acknowledgment indicates acceptance of your order subject to the terms set forth on the acknowledgment.

Bernhardt Design attempts to clarify all purchase orders. However, in the event the price list number and description on the purchase order differ, the price list number will prevail.

Changes/Cancellation

All orders in production are considered firm orders and are not subject to changes or cancellation.

Shipping

Bernhardt Design will ship in accordance with customer instructions whenever possible. For convenience, Bernhardt Design offers a guaranteed freight program (GFP). Bernhardt Design will exercise our best judgment in selecting a carrier under our GFP. When selecting a carrier, Bernhardt Design will make our best effort to meet requested delivery dates.

Transportation lead-times and delays including equipment problems, weather, general traffic, traffic accidents, customer warehouse space, labor disputes, customer changes, etc., that occur on a carrier will not be the responsibility of Bernhardt Design. Furthermore, Bernhardt Design will not be responsible for additional costs incurred due to aforementioned delays.

For customers who decline our GFP, Bernhardt Design will stage orders for pick up at 1% of the list price, or \$75 minimum.

Customer orders in production will be shipped as scheduled and will not be held. Bernhardt Design reserves the right to make partial shipments on any order, unless notified otherwise by the customer.

High quality cartoning meeting trucking and railroad specifications is standard at no extra charge. Some items may be blanket wrapped for shipment.

Freight Damage and Claims

Bernhardt Design is not liable for any damages to products that occur during transit or storage. The carrier assumes all responsibility upon acceptance of product. It is the customer's responsibility to inspect products upon receipt and file any claims with the carrier. No product should be refused. If products are received damaged, a written exception should be made on the bill of lading and an immediate inspection be requested of the carrier.

Concealed damage must be reported to the carrier within 10 business days from date of delivery. Failure to make claims shall constitute acceptance of the products and waiver any claims of defects, errors or shortages.

In the event delivery is made on a Bernhardt Design truck, the products should be carefully inspected for transit damage. If contents are damaged, the driver should be notified to call his dispatcher for immediate disposition.

Concealed damage must be reported within 10 business days from date of delivery and product/packaging held for inspection by a Bernhardt Design representative. Replacements for product damaged in shipment or storage will be manufactured upon receipt of a purchase order.

Returns

No merchandise may be returned to Bernhardt Design without written consent in the form of a Return Authorization from our Quality Assurance Department stating why item is being returned and how item will be shipped.

Unauthorized returns will be automatically refused by our receiving department as well as returns not in accordance with Bernhardt Design shipping instructions. Liability for defective merchandise shall be limited to the replacement or repair of that merchandise, and Bernhardt Design shall not be liable for other damages or losses.

Terms and Credit

Pricing and terms of sale apply to orders accepted by Bernhardt Design, and no terms, stipulations, or conditions contained in the dealer's submitted purchase orders shall have any force or effect. Bernhardt Design requires a completed and signed credit application from every dealer. Bernhardt Design also requires dealers to provide a Blanket Certificate of Resale/Use containing valid sales tax exemption number(s) for their respective state(s).

If credit has been approved, the standard terms for all Bernhardt Design products are Net 30 from the invoice date. In certain instances, as an additional condition of order acceptance, buyer may be required to provide a deposit at time of order and/or remit the balance before shipment is released. If credit has not been approved, a 100% prepayment, including any freight charges, is required prior to production.

Acceptable forms of payment include a certified check or electronic bank transfer. For information on where to send check/electronic bank information contact our Financial Services Department. If a dealer or company check is submitted, three (3) weeks should be allowed for the clearance of the check. If electronic bank transfer is submitted, one (1) week should be allowed for the clearance of the electronic bank transfer. The order is subject to cancellation if payment in full is not received within three (3) weeks from the acknowledgment date.

The dealer may not make deductions for advertising, promotions, quality problems, freight, or any other reason without prior authorization by Bernhardt Design. Such a deduction could result in the curtailment or suspension of further shipments until the matter is resolved. Delinquency notices are generated and mailed periodically. Service charges of 18% per annum will be added to each past-due transaction. Unpaid service charges

will be accrued and invoiced on a periodic basis. Past-due notices may result in orders being held until the situation is resolved. This credit hold could prevent orders from being placed into production or shipped. Orders not in production that are placed on credit hold for three (3) weeks will be subject to cancellation.

Severe past-due situations may result in the employment of a collection agency or other collection litigation. If any collection activity is necessary regarding a dealer account, the dealer will be responsible for the payment of any and all attorney and collection agency fees.

A slow payment history may result in reducing or eliminating an open line of credit. At the discretion of Bernhardt Design, amounts owed by a dealer to Bernhardt Design arising from any transaction or dealings between the dealer and Bernhardt Design may be offset against any amounts owed to the dealer by Bernhardt Design.

Warranty

Bernhardt Design will repair or replace, at its discretion, any product or part thereof which fails as the result of defects in material and workmanship, under single shift use and normal care for five years from date of shipment. This warranty shall apply only to the original purchaser.

This warranty does not cover normal wear and tear, misuse or abuse of product, dramatic temperature changes, exposure to unusual conditions or damages incurred by contact with seating products, tables, desks or other surfaces. Natural color changes, variations or movements in lumber or veneer products, exposure to extreme temperature changes and direct sunlight may cause color changes and/or surface damage. These are circumstances beyond the control of Bernhardt Design and are not warranty issues. Repair or replacement of discontinued product will be at the discretion of Bernhardt Design.

This warranty is the customer's exclusive remedy for product defect and does not apply to damage caused by a freight carrier, dealer, installer, user modification, attachments to a product, or any third party. Bernhardt Design has the exclusive right to make the final determination of product misuse or abuse. Except as stated above, Bernhardt Design makes no express or implied warranties as to any product, and in particular, makes no warranty of merchantability or of fitness for any particular purpose. Bernhardt Design shall not be liable for any consequential or incidental damages or for commercial loss arising from any product defect.

Operational Parts Warranty

Drawer glides, drawer boxes, drawer pulls, and lock mechanisms have a Life-Time Warranty for original purchaser. Power and communication components are warranted for one year.

Parts Order

Bernhardt Design parts have a \$25 net minimum per order. This does not include freight costs.

Custom Design

Bernhardt Design may alter products to meet specific needs. Contact your local sales representative when a custom design is needed. Custom designs,

if approved, require minimum quantities, additional leadtime and upcharges. A custom job number, available from your Bernhardt Design sales representative, must be submitted with purchase orders.

Orders combining custom design with standard product cannot be scheduled for production until custom items are approved. Custom design orders are not subject to revision or cancellation after acknowledgment.

Wood Finishes

Bernhardt Design tables are available in finishes that are compatible with credenzas and seating finishes. However, finishes on tables may vary slightly from those on seating due to the natural characteristics of the wood. No absolute match is implied or guaranteed.

Light Finishes

Bernhardt Design offers lighter finishes on certain veneers and solid woods. When specifying light finishes the natural characteristics of the wood will be visible and color will vary.

Natural characteristics include the natural discolorations of the wood substance and color variations in glued up stock. These natural characteristics are not considered defects by Bernhardt Design, and therefore merchandise will not be replaced.

Special Finishes

Special finishes, made to customer specifications and subject to factory approval, may be available at a **10% net upcharge with a \$500 net minimum**.

Additional leadtime may be required for special finish items. Special finish orders will not be acknowledged until the special finish sample is approved in writing and received by Bernhardt Design Customer Service. Special finish orders are not subject to revision or cancellation after acknowledgment.

Installation and Maintenance

All freestanding tables and credenzas are equipped with leveling devices. Local floor conditions vary, and it is always necessary to properly adjust leveling devices. Proper leveling is essential to the alignment and function of doors and drawers.

Improperly leveled units result in misaligned doors and drawers and may impair locking mechanisms or other functional hardware.

After the initial installation of credenzas, it may be necessary to readjust and align the units to compensate for settling. This should be expected as a matter of routine maintenance and follow-up to assure proper case function.

Proper installation of Bernhardt Design tables and credenzas is the responsibility of the dealer. Improperly installed units can result in permanent damage to case components. Damage due to improperly installed furniture not covered under product warranty.

Orders combining custom design with standard product cannot be scheduled for production until custom items are approved. Custom design orders are not subject to revision or cancellation after acknowledgment.

Care and Cleaning

Finished wood surfaces should be cleaned with a soft damp cloth, wiping in the direction of the grain. Furniture should be buffed dry immediately with a soft cloth.

Design and Patent Rights

All of the products shown in Bernhardt Design catalogs and described in Bernhardt Design price lists are, and remain, the property of Bernhardt Design, with the sole right reserved to manufacture and to distribute.

Some of the product designs shown are patented in the United States and will remain the property of Bernhardt Design. Any reproduction of the products constitutes an infringement of patented copyright laws and will be subject to prosecution.

Environmental

Some tables and credenzas are LEVEL® for ANSI/BIFMA e3-2019 – Furniture Sustainability Standard and SCS Indoor Advantage™ Gold certified. Visit the product page at bernhardtdesign.com for certifications.

Preferred Carrier Guaranteed Freight Rates

Freight charges will be applied to orders as a separate line item based on the zones listed. Rates are based on zones with a minimum for each zone. All zones are located within the Continental United States.

The freight amount is calculated on the total merchandise list COM price. Additional freight fuel surcharges may apply. Rates are based on deliveries made Monday through Friday, 8 am until 5 pm.

All orders are shipped by Bernhardt Design company trucks or preferred carriers specified by Bernhardt Design. **If a purchase order does not specify that the product must ship complete, Bernhardt Design reserves the right to select the most effective shipping method necessary, including split shipments.** Dealer warehouse information, including phone number and contact name, must be specified on the purchase order.

Zone	Percent	Minimum
Zone 1	3%	\$150
Zone 2	4%	\$150
Zone 3	5%	\$150
Zone 4	5.5%	\$150
Zone 5	6%	\$150

Percent bases on List Price.

Direct site deliveries may be requested with an additional freight cost. Requests for direct site deliveries must be made 2 weeks prior to the scheduled ship week and meet the following criteria:

- Minimum of half truckload
- Delivery site accessible by a 53' trailer
- Complete delivery site address with contact name and on-site phone number
- Labor available for unloading

Deliveries that do not meet the criteria must be directed to a receiver warehouse. If a receiver warehouse is not available, the dealer may make arrangements with their own 3rd party carrier. If a 3rd party carrier is elected, a contact name, phone number and e-mail address is required.

Bernhardt Design has a no touch freight policy. Drivers are not allowed to unload freight.

Weekend direct site deliveries will incur a \$500 per trailer weekend delivery fee. Weekend is defined as between 5 pm Friday and 8 am Monday.

Customers who decline GFP should refer to the shipping section of the Terms and Conditions page.

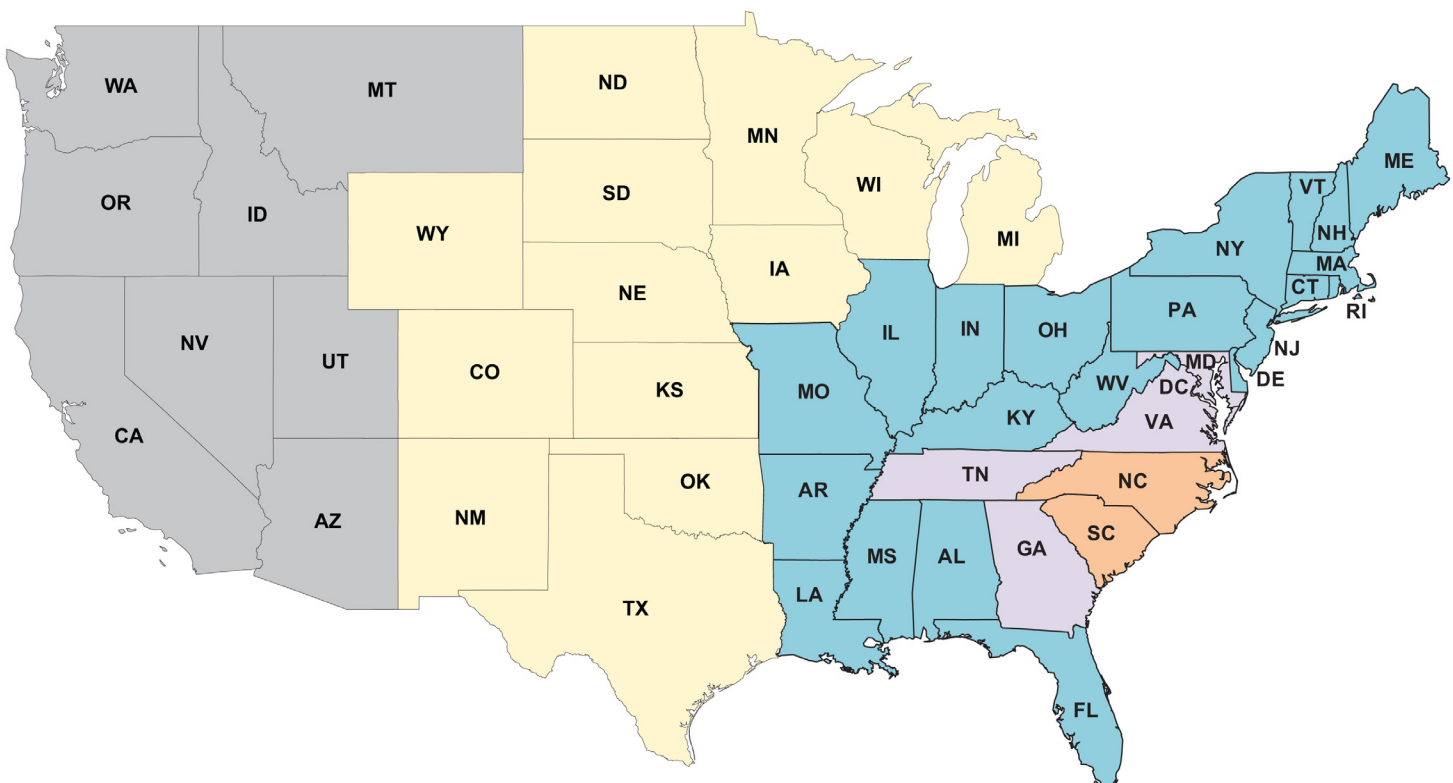

Preferred Carrier Guaranteed Freight Rates - Canada

Freight charges will be applied to orders as a separate line item based on the zones listed. Rates are based on zones with a minimum for each zone.

The freight amount is calculated on the total merchandise list COM price. Additional freight fuel surcharges may apply. Rates are based on deliveries made Monday through Friday, 8 am until 5 pm.

All orders are shipped by Bernhardt Design company trucks or preferred carriers specified by Bernhardt Design. If a purchase order does not specify that the product must ship complete, Bernhardt Design reserves the right to select the most effective shipping method necessary, including split shipments. Dealer warehouse information, including phone number and contact name, must be specified on the purchase order.

Direct site deliveries may be requested with an additional freight cost. Requests for direct site deliveries must be made 2 weeks prior to the scheduled ship week and meet the following criteria:

- Minimum of half truckload
- Delivery site accessible by a 53' trailer
- Complete delivery site address with contact name and on-site phone number
- Labor available for unloading

Deliveries that do not meet the criteria must be directed to a receiver warehouse. If a receiver warehouse is not available, the dealer may make arrangements with their own 3rd party carrier. If a 3rd party carrier is elected, a contact name, phone number and e-mail address is required.

Bernhardt Design has a no touch freight policy. Drivers are not allowed to unload freight.

Weekend direct site deliveries will incur a \$500 per trailer weekend delivery fee. Weekend is defined as between 5 pm Friday and 8 am Monday.

Customers who decline GFP should refer to the shipping section of the Terms and Conditions page.

Zone	Minimums	Freight	Avg. Bus. Days
Zone 1	\$200	5%	10-15
Zone 2	\$200	9%	10-15
Zone 3	\$200	8%	10-15
Zone 4	\$200	11%	10-15
Zone 5	Quote	Quote	

The attached rates are strictly freight and do not include brokerage fees.

