

encore
price list

january 2025

index	2
laminates	3
veneer selection	4-5
design selections + finishes	6
base style selection	7
top selections	8
power overview	9
tops	10-27
under mount power	
under mount power overview	28
under mount power options	29-31
extron MAPP modules	32
mediatrac™ power	
power overview	33
4-trac power system	34
grommet placement kits:	35
laminate, veneer, solid surface	36-41
back-painted glass	42-46
wire management	47
extron APP modules	48-49
terms and conditions	50-52
guaranteed freight	53
guaranteed freight - canada	54

SCS Indoor Advantage™ Gold and LEVEL® 1 certified. See terms and conditions for additional environmental information.

Laminate Selections

A three character sku identifies each laminate selection as well as the standard finish offered. Individual components are priced with standard finish on standard laminate.

A variety of Wilsonart® standard laminates with standard finishes is offered on conference and multipurpose tables. Additional colors may be available but are

subject to upcharges and extended lead times. The laminate option is available on components where noted as an option in the material specification code.

All laminate tops will have a 3mm matching edge band.

PLL Solid Laminate

Standard Solid

- 671 Designer White, Wilsonart D354-60 Matte Finish
- 672 Frosty White, Wilsonart 1573-60 Matte Finish
- 673 Fashion Grey, Wilsonart D381-60 Matte Finish
- 674 North Sea, Wilsonart D90-60 Matte Finish
- 675 Black, Wilsonart 1595-60 Matte Finish

20% Upcharge

- 665 Snow White Velvet, Wilsonart 15501-31 Traceless Laminate
- 666 Charcoal Velvet, Wilsonart 15504-31 Traceless Laminate
- 667 Black Velvet, Wilsonart 15505-31 Traceless Laminate

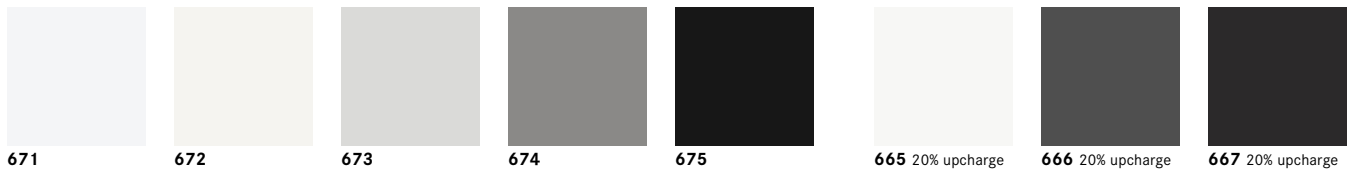

WGL Woodgrain Laminate

Standard Woodgrain

- 684 Phantom Pearl, Wilsonart 8211K-28 Gloss Line Finish w/Aeon Scratch Resistant Protection
- 685 Raw Chestnut, Wilsonart 7975K-12 Soft Grain Finish w/Aeon Scratch Resistant Protection
- 686 High Line, Wilsonart 7970K-18 Linearity Finish w/Aeon Scratch Resistant Protection
- 678 New Age Oak, Wilsonart 7938-16 Casual Rustic Finish
- 679 Brazilwood, Wilsonart 7946-38 Matte Finish
- 687 Boardwalk Oak, Wilsonart 7983-38 Fine Velvet Finish
- 683 Portico Teak (Grey), Wilsonart 8210K-28 Gloss Line Finish
- 681 Studio Teak, Wilsonart 7960-16 Casual Rustic Finish
- 680 Walnut Heights, Wilsonart 7965K-12 Soft Grain Finish
- 682 Asian Night, Wilsonart 7949-16 Casual Rustic Finish



Veneer Selections

A three character sku identifies each species as well as the standard finish offered. Individual components are priced with standard finish. Special finishes on veneers made to customer specifications are subject to factory approval and a 10% net upcharge with a \$500 net minimum.

Transparent stains and sealers are applied in multiple steps to enhance the beauty of the natural wood. A durable, baked-on, top-coat of conversion varnish

or UV topcoat is applied to protect the product. It is recommended that felt, cork or fabric backed desk pads and accessories are used on worksurfaces to minimize wear.

When specifying light finishes the natural characteristics of the wood will be visible and color will vary. Paint finishes are available as custom orders. See terms and conditions for additional finish information.

ASH Ash
Flat Cut

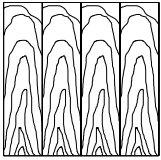

Standard Finish
871 870 839
837 860 861
865 836 866
872 805 845

ASH Select Finishes
M73 M72 M75
M74 M76 M77
M71

MPL Maple
Flat Cut

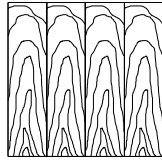

Standard Finish
871 860 861
837 836 823
865 805 866
872 839 845
870

OAK Oak
Rift Cut

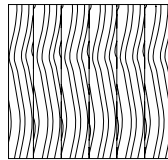

Standard Finish
871 870 839
837 860 861
865 836 866
872 805 845

OAK Select Finishes
M73 M72 M75
M74 M76 M77
M71

PLD Paldao
Quarter Cut

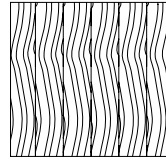

Standard Finish
871 860 823
872 861 866
870 839

WLT Walnut
Flat Cut

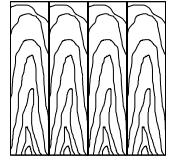

Standard Finish
872 861
870 823
860 866
839

ASH Ash



871

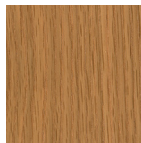

837



865

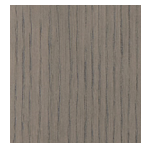

872

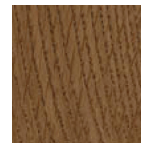

870

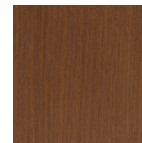

860



836

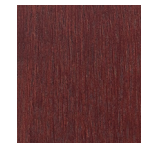

805



839



861



866



845

ASH Select Finishes



M73 Whitewash

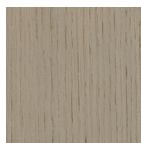

M74 Fawn



M71 Blonde

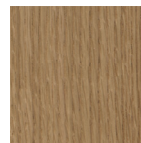

M72 Toast

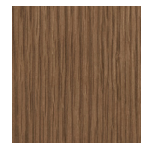

M76 Caramel



M75 Smoke



M77 Coffee

Veneer Selections

MPL Maple



OAK Oak

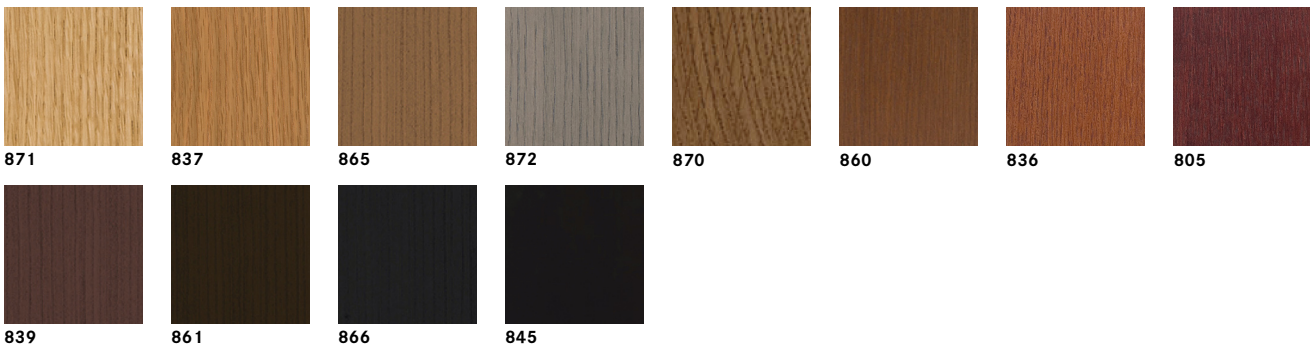

OAK Select Finishes



PLD Paldao

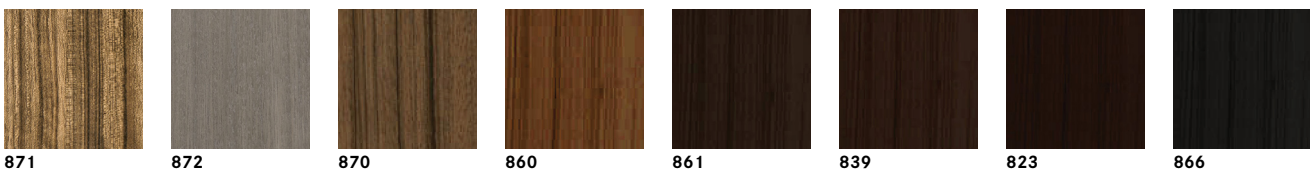

WLT Walnut



Design Selections

Glass Selections

GPW Back-Painted White Glass - 1/2"

GEW Etched, Back-Painted White Glass - 1/2"

Solid Surface Selection

SSF Solid Surface

Standard Finish

CGW Corian®, Glacier White - 1 1/4"

Powder Coat Finishes

A two character sku identifies each powder coat finish offered. Individual skus are priced with standard metal finish. Non-standard finishes may incur an additional charge. The powder coat option is available on skus where noted as an option in the material specification code.

Standard Finish



BA Brushed Aluminum

Powder Coat Finishes - Upcharges apply.

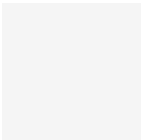

WH Satin White

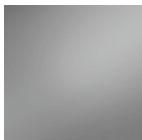

GR Graphite

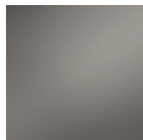

BZ Bronze



IG Iron Grey



RD Black Red

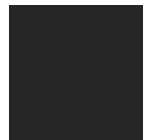

BK Matte Black

Optional Powder Coat Colors - RAL

- Lead Time - Three weeks additional lead-time after color approval
- Net Up-charge - \$1000 for colors shown in Bernhardt Design RAL Powder Coat Selector
- Minimum Order Quantity - None
- Approval Sample Cost - None
- Combining Products - One up-charge is applicable for multiple products on a single purchase order when they are in the same color

Encore Table



The Encore meeting table features a base of quarter cut veneer panels that are mitered on the outside corners. The rectangular base is available veneer and laminate. Bases and tops are specified and sold separately. See the specific top size desired for the appropriate number of bases required.

SCS Indoor Advantage™ Gold and LEVEL® 1 certified. See terms and conditions for additional environmental information.

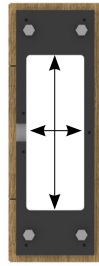

Bottom View
Clear Opening Dimensions:
21" - 11 3/4" x 5 1/2"
25" - 14 3/4" x 5 1/2"
30" - 14 3/4" x 5 1/2"



Base Dimensional Side View

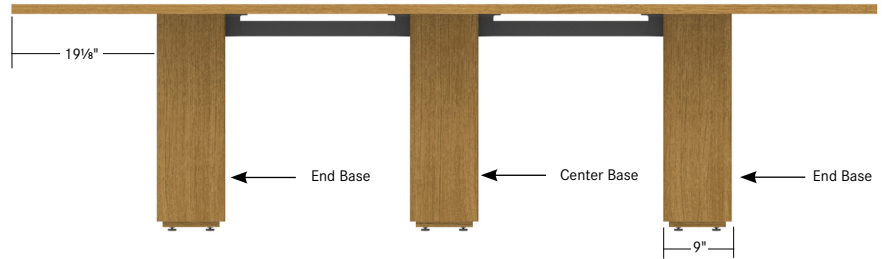

Dimensional Side View

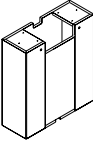
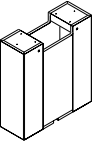
description	sku	w	d	h	specifications	price
 end base	LNS	21	9	28 1/4	laminate	\$ 3063
	LNМ	25	9	28 1/4	laminate	3187
	LNL	30	9	28 1/4	laminate	3313
	ENS	21	9	28 1/4	veneer	4063
	ENM	25	9	28 1/4	veneer	4124
	ENL	30	9	28 1/4	veneer	4186
 center base	LCS	21	9	28 1/4	laminate	3063
	LCM	25	9	28 1/4	laminate	3187
	LCL	30	9	28 1/4	laminate	3313
	ECS	21	9	28 1/4	veneer	4063
	ECM	25	9	28 1/4	veneer	4124
	ECL	30	9	28 1/4	veneer	4186

specification codes example: ECS-SKU

series sku

encore

E	C	S	-				
---	---	---	---	--	--	--	--

material + finish code example: WLT 839

base material	base finish
PLL solid laminate	see pages 3-5
WGL woodgrain laminate	
ASH ash	
MPL maple	
OAK oak	
WLT walnut	
PLD paldao	

Encore Tops

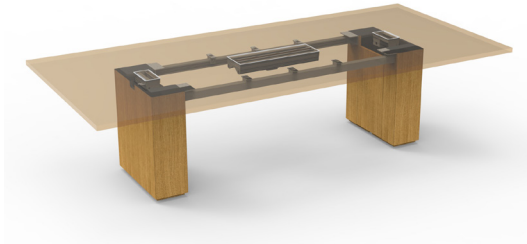

Encore tops are specifically constructed to accommodate the Encore bases. Tops and bases are specified and sold separately. See the specific top size desired for the appropriate number of bases required. Recommended base sizes must be specified to ensure a proper alignment and fit.

Tops 66" - 72" width x 132" - 240" length have 4 sectional veneer matched tops. Encore utilizes a rail system which has a 17¼" inside clearance.

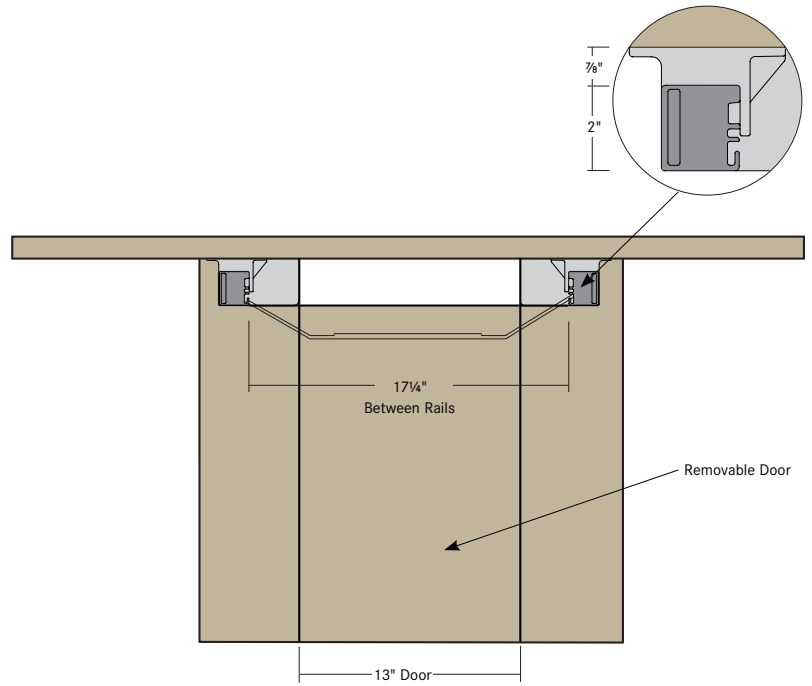

Detail view of Encore top.

Laminate

- PLL Solid Laminate
- WGL Woodgrain Laminate



FL 1¼" Flat RB 1¼" Reverse Bevel

Veneer

- ASH Ash
- MPL Maple
- OAK Oak
- PLD Paldao
- WLT Walnut



FL 1¼" Flat RB 1¼" Reverse Bevel

Glass

- GPW Back-Painted White Glass
- GEW Etched, Back-Painted White Glass

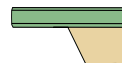

PF ½" Polished Flat

Solid Surface

- SSF Corian®, Glacier White

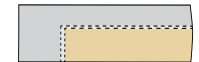

FL 1¼" Flat



RB 1¼" Reverse Bevel

Corner Details

Rectangular



Veneer/Laminate/Corian Edge

Square Corner

Radius Rectangular



Veneer/Laminate/Corian Edge

4" Radius Corner

Arched Rectangular

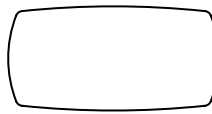

Veneer/Laminate/Corian Edge

4" Radius Corner

Teleconference

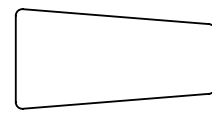

Veneer/Laminate/Corian Edge

4" Radius Corner

specification codes example: QTS-SKU-FLERM01

series	sku	edge	base	grommet location
top		FL 1¼" flat PF ½" polished flat RB 1¼" reverse bevel	ER encore	Under Mount see pages 29-31 for location codes Mediatrac1 see pages 36-46 for location codes 000 none
Q T S -	-		E R	

material + finish code example: PLL 671

top material	top finish
PLL solid laminate	see pages 3-5
WGL woodgrain laminate	
ASH ash	
MPL maple	
OAK oak	
WLT walnut	
PLD paldao	
GPW glass back-painted white	
GEW glass etched back-painted white	
SSF glacier white	

Encore Power Overview



Mediatrac 1 Power



Under Mount Power

Encore Power Options

The Encore conference table offers (2) power solutions: Mediatrac1™ and Under Mount Power.

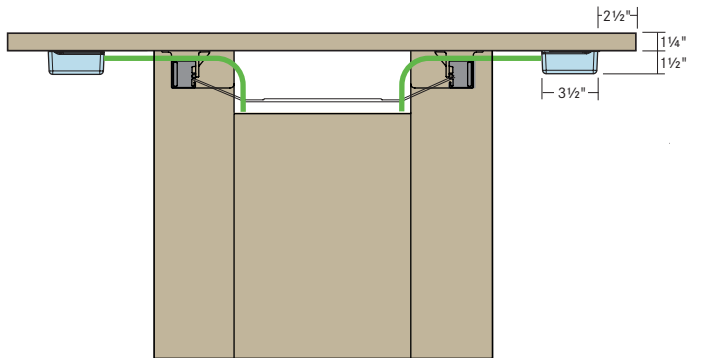
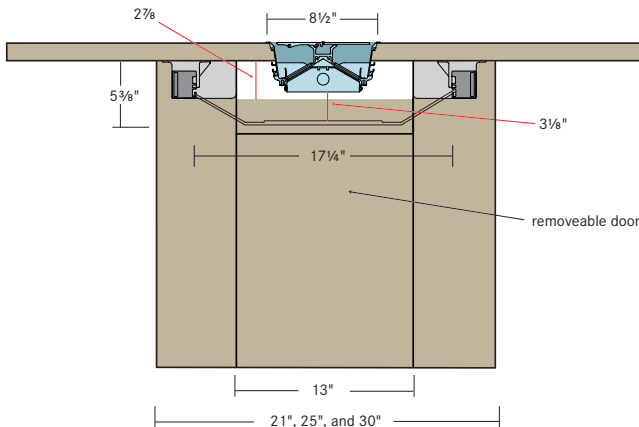

Mediatrac 1™

Mediatrac 1 offers power options that utilize the electrical 4-Trac Power System, allowing for easy installation and reconfiguration capabilities. 4-Trac snaps together easily underneath the worksurface using whips from each power module and the integral 4-Trac jumpers specified for use with each particular Mediatrac 1 grommet size. The grommet layout and wiring scheme is specified specifically for each top size, requiring the customer to separately purchase the grommet kit that fits their needs.

Mediatrac 1 is certified to UL STD 962A, UL STD 1363, CSA STD 22.2 No. 308-14. 4-Trac is certified to UL STD 183 CSA STD 22.2 No. 203.1-14.

Under Mount Power

The Encore conference table collection offers a proprietary under mount power solution allowing quick and easy daisy chaining of modules together. The under mount power module is available in (2) configurations: (2) receptacles, (1) receptacle or (1) USB port and (1) USB-C port. Each module in a kit will be provided with the same configuration as specified by the end user. End user installation will be required per individual SKU. Each SKU includes a separate power infeed with a 10' grounded plug to connect to the power source. See installation instructions for installing.

Under mount power is certified to UL STD 962 A CSA STD 22.2 No. 21.

rectangular top
order bases separately

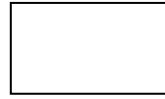

tops 72" - 120" length x 48" - 60" wide
have one sectional veneer top

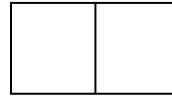

tops 126" - 240" length x 48" - 60" wide
have two sectional veneer tops

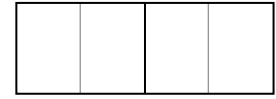

tops 132" - 240" length x 66" - 72" wide
have four sectional veneer tops

sku	l	w	bases to specify	PLL solid laminate WGL woodgrain laminate		ASH ash MPL maple OAK oak WLT walnut		PLD paldao		GPW back-painted white glass	GEW etched back-painted white glass	SSF solid surface	
				FL	RB	FL	RB	FL	RB	PF	FL	RB	
EGB	72	42	(2) 21" bases	2281	2966	3468	4058	4023	4613	9732	11874	7242	8474
EGC	72	48	(2) 25" bases	2491	3239	3587	4197	4161	4771	10058	12271	7430	8694
EHB	78	42	(2) 21" bases	2403	3124	3554	4159	4123	4727	10381	12665	7532	8813
EHC	78	48	(2) 25" bases	2633	3423	3683	4310	4273	4899	10637	12978	7941	9291
EIB	84	42	(2) 21" bases	2843	3696	4070	4762	4722	5414	10723	13083	8129	9511
EIC	84	48	(2) 25" bases	3124	4062	4217	4934	4892	5609	11177	13636	8444	9880
EJB	90	42	(2) 21" bases	3405	4427	4752	5560	5513	6321	11235	13707	8676	10151
EJC	90	48	(2) 25" bases	3748	4873	4934	5773	5724	6563	11711	14288	8956	10479
EJD	90	54	(2) 25" bases	4092	5320	5121	5992	5941	6811	12752	15558	9906	11591
EKB	96	42	(2) 21" bases	3566	4636	4857	5683	5635	6460	11866	14477	9152	10708
EKC	96	48	(2) 25" bases	3930	5109	5057	5917	5867	6726	12291	14996	9461	11070
EKD	96	54	(2) 25" bases	4296	5585	5256	6150	6097	6991	13367	16308	10477	12259
EKE	96	60	(2) 30" bases	4661	6060	5453	6381	6326	7253	14536	17734	11488	13441
ELB	102	42	(2) 21" bases	4162	5411	5398	6316	6262	7180	12498	15248	9578	11207
ELC	102	48	(2) 25" bases	4554	5921	5611	6565	6509	7463	12890	15726	9970	11665
ELD	102	54	(2) 25" bases	4942	6425	5818	6808	6749	7738	14081	17179	11057	12937
ELE	102	60	(2) 30" bases	5327	6926	6029	7054	6994	8019	15235	18587	12138	14202
EMB	108	42	(2) 21" bases	4323	5620	5521	6460	6405	7343	13009	15871	10125	11847
EMC	108	48	(2) 25" bases	4737	6159	5742	6719	6661	7637	13426	16380	10477	12259
EMD	108	54	(2) 25" bases	5148	6693	5965	6980	6920	7934	14700	17934	11627	13604
EME	108	60	(2) 30" bases	5559	7227	6185	7237	7175	8227	15925	19429	12760	14930

specification codes example: QTS-SKU-FLERM01

series	sku	edge	base
top		FL 1¼" flat PF ½" polished flat RB 1¼" reverse bevel	ER encore
Q T S -	-		E R

grommet location
Under Mount see pages 29-31 for location codes
Mediatrac1™ see pages 36-46 for location codes
000 none

material + finish code example: PLL 671

top material	top finish
PLL solid laminate WGL woodgrain laminate ASH ash MPL maple OAK oak WLT walnut PLD paldao GPW glass back-painted white GEW glass etched back-painted white SSF glacier white	see pages 3-5

rectangular top
order bases separately

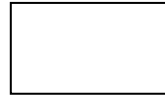

tops 72" - 120" length x 48" - 60" wide
have one sectional veneer top

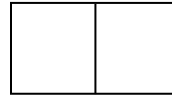

tops 126" - 240" length x 48" - 60" wide
have two sectional veneer tops

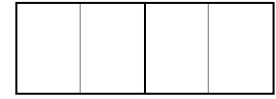

tops 132" - 240" length x 66" - 72" wide
have four sectional veneer tops

sku	l	w	bases to specify	PLL solid laminate WGL woodgrain laminate		ASH ash MPL maple OAK oak WLT walnut		PLD paldao		GPW back-painted white glass	GEW etched back-painted white glass	SSF solid surface	
				FL	RB	FL	RB	FL	RB	PF	FL	RB	
ENB	114	42	(2) 21" bases	4484	5830	5646	6606	6550	7510	13538	16517	10619	12425
ENC	114	48	(2) 25" bases	4919	6395	5879	6879	6820	7820	13997	17077	10987	12855
END	114	54	(2) 25" bases	5354	6961	6110	7149	7088	8127	15312	18681	12200	14274
ENE	114	60	(2) 30" bases	5786	7522	6342	7421	7357	8435	16626	20284	13401	15680
EOB	120	42	(2) 21" bases	4644	6038	5768	6749	6691	7672	14203	17328	11095	12982
EOC	120	48	(2) 25" bases	5103	6634	6013	7036	6976	7998	14604	17817	11488	13441
EOD	120	54	(2) 25" bases	5557	7225	6256	7320	7257	8321	15997	19517	12760	14930
EOE	120	60	(2) 30" bases	6015	7820	6469	7569	7505	8604	17378	21202	14032	16418
EPC	126	48	(2) 25" bases	5610	7293	6968	8153	8083	9268	15569	18995	13854	16210
EPD	126	54	(2) 25" bases	6117	7953	7244	8476	8404	9635	17113	20878	14142	16547
EPE	126	60	(2) 30" bases	6619	8605	7526	8806	8731	10010	18613	22708	15574	18222
EQC	132	48	(3) 25" bases	5797	7537	7157	8374	8303	9519	15756	19223	14040	16427
EQD	132	54	(3) 25" bases	6305	8197	7432	8696	8622	9885	17300	21106	14331	16768
EQE	132	60	(3) 30" bases	6806	8848	7713	9025	8948	10259	18802	22939	15762	18442
EQF	132	66	(3) 30" bases	7309	9502	7994	9353	9274	10633	20346	24823	17202	20127
EQG	132	72	(3) 30" bases	7810	10153	8274	9681	9598	11005	21883	26698	18652	21823
ERC	138	48	(3) 25" bases	5982	7777	7265	8501	8428	9663	17633	21513	14953	17496
ERD	138	54	(3) 25" bases	6528	8487	7568	8855	8779	10066	18349	22386	15310	17913
ERE	138	60	(3) 30" bases	7077	9201	7871	9210	9131	10469	20004	24405	16886	19757
ERF	138	66	(3) 30" bases	8014	10419	8800	10296	10208	11704	21696	26470	18464	21603
ERG	138	72	(3) 30" bases	8564	11134	9106	10655	10563	12111	23350	28487	20022	23426

specification codes example: QTS-SKU-FLERM01

series	sku	edge	base
top		FL 1¼" flat PF ½" polished flat RB 1¼" reverse bevel	ER encore
Q T S -	-		E R

grommet location
Under Mount see pages 29-31 for location codes
Mediatrac1™ see pages 36-46 for location codes
000 none

material + finish code example: PLL 671

top material	top finish
PLL solid laminate WGL woodgrain laminate ASH ash MPL maple OAK oak WLT walnut PLD paldao GPW glass back-painted white GEW glass etched back-painted white SSF glacier white	see pages 3-5

rectangular top
order bases separately

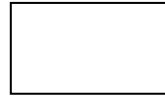

tops 72" - 120" length x 48" - 60" wide
have one sectional veneer top

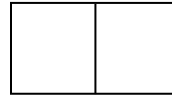

tops 126" - 240" length x 48" - 60" wide
have two sectional veneer tops

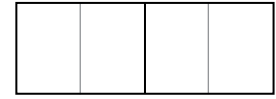

tops 132" - 240" length x 66" - 72" wide
have four sectional veneer tops

sku	l	w	bases to specify	PLL solid laminate WGL woodgrain laminate		ASH ash MPL maple OAK oak WLT walnut		PLD paldao		GPW back-painted white glass	GEW etched back-painted white glass	SSF solid surface	
				FL	RB	FL	RB	FL	RB	PF	FL	RB	
ESC	144	48	(3) 25" bases	6169	8020	7453	8721	8646	9913	17820	21741	15140	17714
ESD	144	54	(3) 25" bases	6715	8730	7756	9075	8997	10316	18535	22613	15499	18134
ESE	144	60	(3) 30" bases	7264	9444	8058	9428	9348	10718	20191	24634	17073	19976
ESF	144	66	(3) 30" bases	8202	10663	8987	10515	10425	11953	21883	26698	18652	21823
ESG	144	72	(3) 30" bases	8752	11378	9292	10872	10779	12359	23537	28716	20209	23645
ETC	150	48	(3) 25" bases	6594	8573	7446	8712	8638	9904	18795	22930	15676	18341
ETD	150	54	(3) 25" bases	6940	9022	7837	9170	9091	10424	19782	24135	16501	19307
ETE	150	60	(3) 30" bases	7535	9796	8161	9549	9467	10855	21558	26301	18194	21287
ETF	150	66	(3) 30" bases	8518	11074	9177	10738	10646	12206	23356	28495	19897	23280
ETG	150	72	(3) 30" bases	9115	11850	9504	11120	11025	12641	25208	30754	21411	25051
EUC	156	48	(3) 25" bases	6771	8803	7624	8921	8844	10140	18972	23146	15855	18551
EUD	156	54	(3) 25" bases	7128	9267	8025	9390	9309	10674	19971	24365	16688	19525
EUE	156	60	(3) 30" bases	7721	10038	8350	9770	9686	11106	21746	26531	18380	21505
EUF	156	66	(3) 30" bases	8706	11318	9364	10956	10863	12455	23544	28724	20083	23498
EUG	156	72	(3) 30" bases	9302	12093	9691	11339	11242	12890	25396	30984	21599	25271
EVC	162	48	(3) 25" bases	7400	9620	8096	9473	9392	10768	20004	24405	16720	19563
EVD	162	54	(3) 25" bases	7788	10125	8520	9969	9884	11332	21055	25688	17597	20589
EVE	162	60	(3) 30" bases	8427	10956	8868	10376	10287	11795	22973	28028	19380	22675
EVF	162	66	(3) 30" bases	9459	12297	9958	11651	11552	13245	24936	30422	21158	24755
EVG	162	72	(3) 30" bases	10101	13132	10303	12055	11952	13703	26863	32773	22940	26840
EWC	168	48	(3) 25" bases	7578	9852	8274	9681	9598	11005	20182	24623	16897	19770
EWD	168	54	(3) 25" bases	7976	10369	8707	10188	10101	11581	21244	25918	17784	20808
EWE	168	60	(3) 30" bases	8613	11197	9055	10595	10504	12044	23160	28256	19568	22895
EWF	168	66	(3) 30" bases	9648	12543	10146	11871	11770	13495	25124	30652	21345	24974
EWG	168	72	(3) 30" bases	10288	13375	10490	12274	12169	13952	27050	33001	23127	27059

specification codes example: QTS-SKU-FLERM01

series	sku	edge	base
top		FL 1¼" flat PF ½" polished flat RB 1¼" reverse bevel	ER encore
Q T S -	-		E R

grommet location
Under Mount see pages 29-31 for location codes
Mediatrac1™ see pages 36-46 for location codes
000 none

material + finish code example: PLL 671

top material	top finish
PLL solid laminate WGL woodgrain laminate ASH ash MPL maple OAK oak WLT walnut PLD paldao GPW glass back-painted white GEW glass etched back-painted white SSF glacier white	see pages 3-5

rectangular top
order bases separately

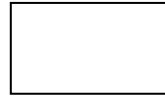

tops 72" - 120" length x 48" - 60" wide
have one sectional veneer top

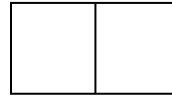

tops 126" - 240" length x 48" - 60" wide
have two sectional veneer tops

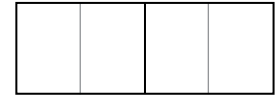

tops 132" - 240" length x 66" - 72" wide
have four sectional veneer tops

sku	l	w	bases to specify	PLL solid laminate WGL woodgrain laminate		ASH ash MPL maple OAK oak WLT walnut		PLD paldao		GPW back-painted white glass	GEW etched back-painted white glass	SSF solid surface	
				FL	RB	FL	RB	FL	RB	PF	FL	RB	
EXC	174	48	(3) 25" bases	7790	10127	8349	9769	9685	11105	21224	25894	17812	20841
EXD	174	54	(3) 25" bases	8201	10662	8786	10280	10192	11686	22342	27258	18750	21938
EXE	174	60	(3) 30" bases	8885	11551	9158	10715	10624	12181	24424	29798	20652	24163
EXF	174	66	(3) 30" bases	9963	12952	10394	12161	12058	13825	26506	32338	22581	26420
EXG	174	72	(3) 30" bases	10649	13844	10768	12599	12491	14322	28585	34874	24457	28615
EYC	180	48	(3) 25" bases	7968	10359	8526	9976	9891	11340	21403	26112	17990	21049
EYD	180	54	(3) 25" bases	8387	10904	8975	10501	10411	11937	22529	27486	18937	22157
EYE	180	60	(3) 30" bases	9073	11795	9345	10934	10841	12429	24611	30026	20839	24382
EYF	180	66	(3) 30" bases	10150	13195	10582	12381	12276	14075	26694	32567	22768	26639
EYG	180	72	(3) 30" bases	10836	14087	10956	12819	12709	14572	28773	35104	24645	28835
EZC	186	48	(3) 25" bases	8182	10637	8687	10164	10077	11554	22911	27952	18893	22105
EZD	186	54	(3) 25" bases	8612	11196	9143	10698	10606	12161	24116	29422	19886	23267
EZE	186	60	(3) 30" bases	9345	12149	9537	11159	11063	12685	26318	32108	21924	25652
EZF	186	66	(3) 30" bases	10647	13842	11015	12888	12778	14650	28534	34812	23956	28029
EZG	186	72	(3) 30" bases	11377	14791	11407	13347	13233	15172	30771	37541	25983	30401
E1C	192	48	(3) 25" bases	8360	10868	8863	10370	10282	11788	23090	28170	19071	22314
E1D	192	54	(3) 25" bases	8800	11440	9331	10918	10824	12411	24303	29650	20075	23488
E1E	192	60	(3) 30" bases	9533	12393	9726	11380	11283	12936	26505	32337	22111	25870
E1F	192	66	(3) 30" bases	10834	14085	11203	13108	12996	14900	28721	35040	24144	28249
E1G	192	72	(3) 30" bases	11563	15032	11594	13565	13450	15421	30957	37768	26171	30621
E2C	198	48	(3) 25" bases	8569	11140	8939	10459	10370	11889	24078	29376	19987	23385
E2D	198	54	(3) 25" bases	9018	11724	9408	11008	10914	12513	25345	30921	21038	24615
E2E	198	60	(3) 30" bases	9802	12743	9827	11498	11400	13070	27699	33793	23511	27508
E2F	198	66	(3) 30" bases	11185	14541	11387	13323	13209	15145	30090	36710	25678	30044
E2G	198	72	(3) 30" bases	11962	15551	11803	13810	13692	15698	32428	39563	27835	32567

specification codes example: QTS-SKU-FLERM01

series	sku	edge	base	grommet location	material + finish code example: PLL 671	top finish
top		FL 1¼" flat PF ½" polished flat RB 1¼" reverse bevel	ER encore	Under Mount see pages 29-31 for location codes Mediatrac1™ see pages 36-46 for location codes 000 none	PLL solid laminate WGL woodgrain laminate ASH ash MPL maple OAK oak WLT walnut PLD paldao GPW glass back-painted white GEW glass etched back-painted white SSF glacier white	see pages 3-5
Q T S -	-		E R			

rectangular top
order bases separately

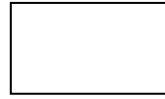

tops 72" - 120" length x 48" - 60" wide
have one sectional veneer top

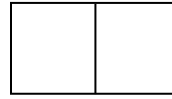

tops 126" - 240" length x 48" - 60" wide
have two sectional veneer tops

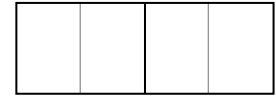

tops 132" - 240" length x 66" - 72" wide
have four sectional veneer tops

sku	l	w	bases to specify	PLL solid laminate WGL woodgrain laminate		ASH ash MPL maple OAK oak WLT walnut		PLD paldao		GPW back-painted white glass	GEW etched back-painted white glass	SSF solid surface	
				FL	RB	FL	RB	FL	RB	PF	FL	RB	
E3C	204	48	(3) 25" bases	8746	11370	9117	10667	10576	12126	24255	29592	20164	23592
E3D	204	54	(3) 25" bases	9207	11970	9596	11228	11132	12763	25531	31148	21225	24834
E3E	204	60	(3) 30" bases	9990	12987	10015	11718	11618	13320	27887	34023	23699	27728
E3F	204	66	(3) 30" bases	11373	14785	11576	13544	13429	15397	30277	36938	25865	30263
E3G	204	72	(3) 30" bases	12149	15794	11991	14030	13910	15949	32616	39792	28023	32787
E4C	210	48	(3) 25" bases	8964	11654	9193	10756	10664	12227	25358	30937	21623	25299
E4D	210	54	(3) 25" bases	9434	12265	9678	11324	11227	12872	26693	32566	22759	26629
E4E	210	60	(3) 30" bases	10260	13338	10118	11839	11737	13457	29150	35563	25045	29303
E4F	210	66	(3) 30" bases	11724	15242	11806	13814	13695	15702	31655	38620	27333	31980
E4G	210	72	(3) 30" bases	12547	16312	12246	14328	14206	16288	34149	41662	29608	34642
E5C	216	48	(3) 25" bases	9142	11885	9373	10967	10873	12467	25537	31156	21801	25508
E5D	216	54	(3) 25" bases	9623	12510	9864	11541	11443	13120	26880	32794	22947	26848
E5E	216	60	(3) 30" bases	10447	13582	10305	12057	11954	13706	29338	35793	25232	29522
E5F	216	66	(3) 30" bases	11911	15485	11992	14031	13911	15950	31843	38849	27520	32199
E5G	216	72	(3) 30" bases	12734	16555	12433	14547	14423	16536	34336	41890	29796	34862
E6C	222	48	(3) 25" bases	9773	12705	9846	11520	11422	13096	26525	32361	22781	26654
E6D	222	54	(3) 25" bases	10286	13372	10363	12125	12022	13783	27920	34063	23979	28056
E6E	222	60	(3) 30" bases	11153	14499	10825	12666	12557	14398	30527	37243	26385	30871
E6F	222	66	(3) 30" bases	12698	16508	12648	14799	14672	16822	33245	40559	28804	33701
E6G	222	72	(3) 30" bases	13568	17639	13107	15336	15205	17433	35904	43803	31248	36561
E7C	228	48	(4) 25" bases	9950	12935	10024	11729	11628	13332	26704	32579	22957	26860
E7D	228	54	(4) 25" bases	10474	13617	10551	12345	12240	14033	28108	34292	24167	28276
E7E	228	60	(4) 30" bases	11340	14742	11012	12885	12774	14646	30715	37473	26574	31092
E7F	228	66	(4) 30" bases	12884	16750	12835	15017	14889	17071	33431	40786	28993	33922
E7G	228	72	(4) 30" bases	13757	17885	13294	15554	15422	17682	36093	44034	31437	36782

specification codes example: QTS-SKU-FLERM01

series	sku	edge	base
top		FL 1¼" flat PF ½" polished flat RB 1¼" reverse bevel	ER encore
Q T S -	-		E R

grommet location
Under Mount see pages 29-31 for location codes
Mediatrac1™ see pages 36-46 for location codes
000 none

material + finish code example: PLL 671

top material	top finish
PLL solid laminate WGL woodgrain laminate ASH ash MPL maple OAK oak WLT walnut PLD paldao GPW glass back-painted white GEW glass etched back-painted white SSF glacier white	see pages 3-5

rectangular top
order bases separately

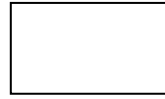

tops 72" - 120" length x 48" - 60" wide
have one sectional veneer top

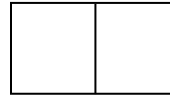

tops 126" - 240" length x 48" - 60" wide
have two sectional veneer tops

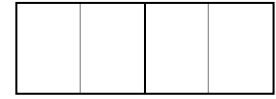

tops 132" - 240" length x 66" - 72" wide
have four sectional veneer tops

sku	l	w	bases to specify	PLL solid laminate WGL woodgrain laminate		ASH ash MPL maple OAK oak WLT walnut		PLD paldao		GPW back-painted white glass	GEW etched back-painted white glass	SSF solid surface	
				FL	RB	FL	RB	FL	RB	PF	FL	RB	
E8C	234	48	(4) 25" bases	10161	13210	10104	11822	11721	13439	27707	33803	23867	27925
E8D	234	54	(4) 25" bases	10697	13907	10634	12442	12336	14144	29166	35583	25124	29396
E8E	234	60	(4) 30" bases	11610	15093	11197	13101	12989	14893	31940	38967	27668	32372
E8F	234	66	(4) 30" bases	13237	17209	13078	15302	15171	17394	34787	42441	30276	35423
E8G	234	72	(4) 30" bases	14150	18395	13559	15865	15729	18034	37637	45918	32819	38399
E9C	240	48	(4) 25" bases	10340	13442	10281	12029	11926	13674	27887	34023	24046	28134
E9D	240	54	(4) 25" bases	10884	14150	10823	12663	12555	14395	29352	35810	25310	29613
E9E	240	60	(4) 30" bases	11798	15338	11383	13319	13205	15140	32127	39195	27854	32590
E9F	240	66	(4) 30" bases	13425	17453	13265	15521	15388	17643	34975	42670	30464	35643
E9G	240	72	(4) 30" bases	14336	18637	13747	16084	15947	18284	37823	46145	33005	38616

specification codes example: QTS-SKU-FLERM01

series	sku	edge	base
top		FL 1/4" flat PF 1/2" polished flat RB 1/4" reverse bevel	ER encore
Q T S -	-		E R

grommet location
Under Mount see pages 29-31 for location codes
Mediatrac™ see pages 36-46 for location codes
000 none

material + finish code example: PLL 671

top material	top finish
PLL solid laminate WGL woodgrain laminate ASH ash MPL maple OAK oak WLT walnut PLD paldao GPW glass back-painted white GEW glass etched back-painted white SSF glacier white	see pages 3-5

radius rectangular top
order bases separately

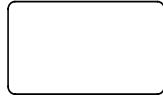

tops 72" - 120" length x 48" - 60" wide
have one sectional veneer top

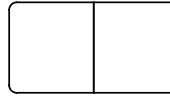

tops 126" - 240" length x 48" - 60" wide
have two sectional veneer tops

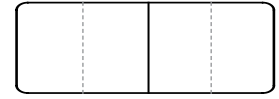

tops 132" - 240" length x 66" - 72" wide
have four sectional veneer tops

sku	l	w	bases to specify	PLL solid laminate WGL woodgrain laminate		ASH ash MPL maple OAK oak WLT walnut		PLD paldao		GPW back-painted white glass	GEW etched back-painted white glass	SSF solid surface	
				FL	RB	FL	RB	FL	RB	PF	FL	RB	
FGB	72	42	(2) 21" bases	3340	4342	4160	4868	4826	5533	10559	12882	8505	9951
FGC	72	48	(2) 25" bases	3660	4758	4306	5039	4995	5727	10885	13280	8803	10300
FHB	78	42	(2) 21" bases	3527	4586	4260	4985	4942	5666	11124	13572	8948	10470
FHC	78	48	(2) 25" bases	3871	5033	4417	5168	5124	5875	11849	14456	9331	10918
FIB	84	42	(2) 21" bases	3715	4830	5033	5889	5839	6694	11463	13985	9612	11247
FIC	84	48	(2) 25" bases	4089	5316	5219	6107	6055	6942	12385	15110	9834	11506
FJB	90	42	(2) 21" bases	3902	5073	5573	6521	6465	7413	12036	14684	10040	11747
FJC	90	48	(2) 25" bases	4302	5593	5789	6774	6716	7700	12924	15768	10295	12046
FJD	90	54	(2) 25" bases	4700	6110	6012	7035	6974	7996	13964	17037	11390	13327
FKB	96	42	(2) 21" bases	4089	5316	5700	6669	6612	7581	12609	15383	10416	12187
FKC	96	48	(2) 25" bases	4514	5869	5936	6946	6886	7895	13503	16474	10875	12724
FKD	96	54	(2) 25" bases	4940	6422	6172	7222	7160	8209	14614	17830	12044	14092
FKE	96	60	(2) 30" bases	5367	6978	6408	7498	7434	8523	15686	19137	13215	15462
FLB	102	42	(2) 21" bases	4782	6217	6331	7408	7344	8421	13238	16151	11012	12885
FLC	102	48	(2) 25" bases	5240	6812	6580	7699	7633	8752	14032	17120	11474	13425
FLD	102	54	(2) 25" bases	5692	7400	6832	7994	7926	9087	15224	18574	12711	14872
FLE	102	60	(2) 30" bases	6145	7989	7079	8283	8212	9416	16422	20035	13957	16330
FMB	108	42	(2) 21" bases	4971	6463	6478	7580	7515	8616	13750	16775	11711	13702
FMC	108	48	(2) 25" bases	5452	7088	6740	7886	7819	8965	14700	17934	12044	14092
FMD	108	54	(2) 25" bases	5932	7712	7006	8198	8127	9318	15925	19429	13367	15640
FME	108	60	(2) 30" bases	6411	8335	7266	8502	8429	9664	17153	20927	14678	17174

specification codes example: QTS-SKU-FLERM01

series	sku	edge	base
top		FL 1¼" flat PF ½" polished flat RB 1¼" reverse bevel	ER encore
Q T S -	-		E R

grommet location
Under Mount see pages 29-31 for location codes
Mediatrac TM see pages 36-46 for location codes
000 none

material + finish code example: PLL 671

top material	top finish
PLL solid laminate WGL woodgrain laminate ASH ash MPL maple OAK oak WLT walnut PLD paldao GPW glass back-painted white GEW glass etched back-painted white SSF glacier white	see pages 3-5

radius rectangular top
order bases separately

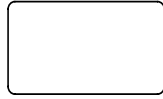

tops 72" - 120" length x 48" - 60" wide
have one sectional veneer top

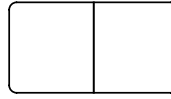

tops 126" - 240" length x 48" - 60" wide
have two sectional veneer tops

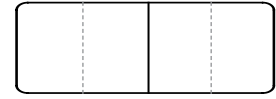

tops 132" - 240" length x 66" - 72" wide
have four sectional veneer tops

sku	l	w	bases to specify	PLL solid laminate WGL woodgrain laminate		ASH ash MPL maple OAK oak WLT walnut		PLD paldao		GPW back-painted white glass	GEW etched back-painted white glass	SSF solid surface	
				FL	RB	FL	RB	FL	RB	PF	FL	RB	
FNB	114	42	(2) 21" bases	5157	6705	6621	7747	7681	8806	14281	17423	12258	14342
FNC	114	48	(2) 25" bases	5663	7362	6898	8071	8002	9175	15224	18574	12632	14780
FND	114	54	(2) 25" bases	6172	8024	7178	8399	8327	9547	16539	20178	14032	16418
FNE	114	60	(2) 30" bases	6678	8682	7453	8721	8646	9913	17845	21771	15413	18034
FOB	120	42	(2) 21" bases	5343	6946	6770	7921	7854	9005	14944	18232	12838	15021
FOC	120	48	(2) 25" bases	5881	7646	7060	8261	8190	9390	15787	19261	13215	15462
FOD	120	54	(2) 25" bases	6411	8335	7352	8602	8529	9779	17179	20959	14678	17174
FOE	120	60	(2) 30" bases	6944	9028	7603	8896	8820	10112	18572	22658	16131	18874
FPC	126	48	(2) 25" bases	6741	8764	8064	9435	9355	10726	17353	21171	16180	18931
FPD	126	54	(2) 25" bases	7094	9223	8487	9930	9845	11288	18264	22283	17030	19926
FPE	126	60	(2) 30" bases	7668	9969	8811	10309	10221	11719	19765	24114	17940	20990
FQC	132	48	(3) 25" bases	6692	8700	8345	9764	9681	11099	16915	20637	16150	18896
FQD	132	54	(3) 25" bases	7282	9467	8674	10149	10062	11537	18452	22512	17219	20147
FQE	132	60	(3) 30" bases	7857	10215	9000	10530	10440	11970	19952	24342	18129	21211
FQF	132	66	(3) 30" bases	8455	10992	9324	10910	10816	12401			19780	23143
FQG	132	72	(3) 30" bases	9040	11752	9649	11290	11193	12834			21435	25079
FRC	138	48	(3) 25" bases	7191	9349	8418	9850	9765	11196	18680	22790	16752	19600
FRD	138	54	(3) 25" bases	7568	9839	8860	10367	10278	11784	19663	23989	17633	20631
FRE	138	60	(3) 30" bases	8210	10673	9215	10782	10690	12256	21319	26010	19441	22746
FRF	138	66	(3) 30" bases	9307	12100	10299	12050	11947	13698			21270	24886
FRG	138	72	(3) 30" bases	9945	12929	10652	12463	12357	14168			23057	26977

specification codes example: QTS-SKU-FLERM01

series	sku	edge	base	grommet location	material + finish code example: PLL 671	top finish
top		FL 1¼" flat PF ½" polished flat RB 1¼" reverse bevel	ER encore	Under Mount see pages 29-31 for location codes Mediatrac1™ see pages 36-46 for location codes 000 none	PLL solid laminate WGL woodgrain laminate ASH ash MPL maple OAK oak WLT walnut PLD paldao GPW glass back-painted white GEW glass etched back-painted white SSF glacier white	see pages 3-5
Q T S -	-		E R			

radius rectangular top
order bases separately

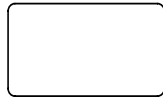

tops 72" - 120" length x 48" - 60" wide
have one sectional veneer top

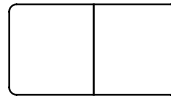

tops 126" - 240" length x 48" - 60" wide
have two sectional veneer tops

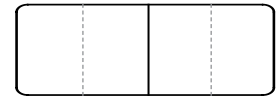

tops 132" - 240" length x 66" - 72" wide
have four sectional veneer tops

sku	l	w	bases to specify	PLL solid laminate WGL woodgrain laminate		ASH ash MPL maple OAK oak WLT walnut		PLD paldao		GPW back-painted white glass	GEW etched back-painted white glass	SSF solid surface	
				FL	RB	FL	RB	FL	RB	PF	FL	RB	
FSC	144	48	(3) 25" bases	7369	9580	8595	10057	9971	11432	18858	23007	16930	19809
FSD	144	54	(3) 25" bases	7756	10083	9048	10587	10496	12034	19851	24219	17820	20850
FSE	144	60	(3) 30" bases	8398	10918	9403	11002	10908	12506	21507	26239	19628	22965
FSF	144	66	(3) 30" bases	9494	12343	10486	12269	12164	13947			21457	25105
FSG	144	72	(3) 30" bases	10133	13173	10838	12681	12573	14415			23246	27198
FTC	150	48	(3) 25" bases	7650	9945	8716	10198	10111	11593	19912	24293	18050	21119
FTD	150	54	(3) 25" bases	8052	10468	9174	10734	10642	12202	20960	25572	18999	22229
FTE	150	60	(3) 30" bases	8745	11369	9554	11179	11083	12707	22732	27734	20960	24524
FTF	150	66	(3) 30" bases	9895	12864	10561	12357	12251	14047			22922	26819
FTG	150	72	(3) 30" bases	10587	13764	11113	13003	12892	14781			24660	28853
FUC	156	48	(3) 25" bases	7829	10178	8894	10406	10318	11830	20089	24509	18229	21328
FUD	156	54	(3) 25" bases	8239	10711	9362	10954	10860	12452	21148	25801	19186	22448
FUE	156	60	(3) 30" bases	8933	11613	9741	11397	11300	12956	22920	27963	21148	24744
FUF	156	66	(3) 30" bases	10083	13108	10749	12577	12469	14297			23109	27038
FUG	156	72	(3) 30" bases	10775	14008	11301	13223	13110	15031			24848	29073
FVC	162	48	(3) 25" bases	8594	11173	9474	11085	10990	12601	21129	25778	19263	22538
FVD	162	54	(3) 25" bases	9045	11759	9970	11665	11566	13261	22242	27136	20277	23725
FVE	162	60	(3) 30" bases	9791	12729	10378	12143	12039	13803	24167	29484	22323	26118
FVF	162	66	(3) 30" bases	10992	14290	11646	13626	13510	15490			24374	28518
FVG	162	72	(3) 30" bases	11740	15262	12053	14103	13982	16031			26421	30913
FWC	168	48	(3) 25" bases	8772	11404	9652	11293	11197	12838	21307	25995	19441	22746
FWD	168	54	(3) 25" bases	9233	12003	10158	11885	11784	13511	22428	27363	20464	23943
FWE	168	60	(3) 30" bases	9978	12972	10564	12360	12255	14051	24353	29711	22509	26336
FWF	168	66	(3) 30" bases	11180	14534	11834	13846	13728	15740			24561	28737
FWG	168	72	(3) 30" bases	11928	15507	12240	14321	14199	16280			26607	31131

specification codes example: QTS-SKU-FLERM01

series	sku	edge	base	grommet location	material + finish code example: PLL 671	top finish
top		FL 1¼" flat PF ½" polished flat RB 1¼" reverse bevel	ER encore	Under Mount see pages 29-31 for location codes Mediatrac1™ see pages 36-46 for location codes 000 none	PLL solid laminate WGL woodgrain laminate ASH ash MPL maple OAK oak WLT walnut PLD paldao GPW glass back-painted white GEW glass etched back-painted white SSF glacier white	see pages 3-5
Q T S -	-		E R			

radius rectangular top
order bases separately



tops 72" - 120" length x 48" - 60" wide
have one sectional veneer top

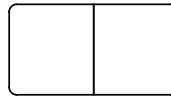

tops 126" - 240" length x 48" - 60" wide
have two sectional veneer tops

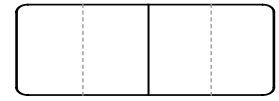

tops 132" - 240" length x 66" - 72" wide
have four sectional veneer tops

sku	l	w	bases to specify	PLL solid laminate WGL woodgrain laminate		ASH ash MPL maple OAK oak WLT walnut		PLD paldao		GPW back-painted white glass	GEW etched back-painted white glass	SSF solid surface	
				FL	RB	FL	RB	FL	RB	PF	FL	RB	
FXC	174	48	(3) 25" bases	9051	11767	9769	11430	11333	12993	22295	27200	20511	23998
FXD	174	54	(3) 25" bases	9527	12386	10284	12033	11930	13678	23468	28631	21592	25263
FXE	174	60	(3) 30" bases	10320	13416	10716	12538	12431	14253	25548	31169	23775	27817
FXF	174	66	(3) 30" bases	11578	15052	12157	14224	14103	16169			25995	30415
FXG	174	72	(3) 30" bases	12381	16096	12592	14733	14607	16748			28142	32927
FYC	180	48	(3) 25" bases	9229	11998	9947	11638	11539	13230	22474	27419	20691	24209
FYD	180	54	(3) 25" bases	9714	12629	10470	12250	12146	13926	23655	28860	21779	25482
FYE	180	60	(3) 30" bases	10509	13662	10904	12758	12649	14503	25734	31396	23961	28035
FYF	180	66	(3) 30" bases	11765	15295	12344	14443	14320	16418			26182	30633
FYG	180	72	(3) 30" bases	12568	16339	12779	14952	14824	16997			28328	33144
FZC	186	48	(3) 25" bases	9502	12353	10164	11892	11791	13519	23543	28723	21752	25450
FZD	186	54	(3) 25" bases	10001	13002	10700	12519	12412	14231	24781	30233	22896	26789
FZE	186	60	(3) 30" bases	10858	14116	11157	13054	12943	14839	26980	32916	25241	29532
FZF	186	66	(3) 30" bases	12376	16089	12877	15067	14938	17127			27565	32252
FZG	186	72	(3) 30" bases	13229	17198	13336	15604	15470	17737			29909	34994
F1C	192	48	(3) 25" bases	9680	12584	10343	12102	11998	13757	23721	28940	21930	25659
F1D	192	54	(3) 25" bases	10188	13245	10886	12737	12628	14479	24969	30463	23082	27006
F1E	192	60	(3) 30" bases	11045	14359	11344	13273	13160	15088	27168	33145	25428	29751
F1F	192	66	(3) 30" bases	12563	16332	13063	15284	15154	17374			27752	32470
F1G	192	72	(3) 30" bases	13416	17441	13525	15825	15689	17989			30096	35213
F2C	198	48	(3) 25" bases	9960	12948	10459	12238	12133	13911	24710	30147	23005	26916
F2D	198	54	(3) 25" bases	10483	13628	11010	12882	12772	14644	26009	31731	24217	28334
F2E	198	60	(3) 30" bases	11390	14807	11495	13450	13335	15289	28356	34595	27072	31675
F2F	198	66	(3) 30" bases	13005	16907	13315	15579	15446	17709			29558	34583
F2G	198	72	(3) 30" bases	13912	18086	13800	16146	16008	18354			32032	37478

specification codes example: QTS-SKU-FLERM01

series	sku	edge	base	grommet location	material + finish code example: PLL 671	top finish
top		FL 1¼" flat PF ½" polished flat RB 1¼" reverse bevel	ER encore	Under Mount see pages 29-31 for location codes Mediatrac1™ see pages 36-46 for location codes 000 none	PLL solid laminate WGL woodgrain laminate ASH ash MPL maple OAK oak WLT walnut PLD paldao GPW glass back-painted white GEW glass etched back-painted white SSF glacier white	see pages 3-5
Q T S -	-		E R			

radius rectangular top
order bases separately



tops 72" - 120" length x 48" - 60" wide
have one sectional veneer top

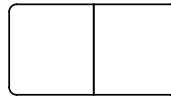

tops 126" - 240" length x 48" - 60" wide
have two sectional veneer tops

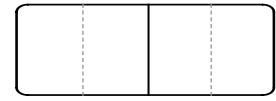

tops 132" - 240" length x 66" - 72" wide
have four sectional veneer tops

sku	l	w	bases to specify	PLL solid laminate WGL woodgrain laminate		ASH ash MPL maple OAK oak WLT walnut		PLD paldao		GPW back-painted white glass	GEW etched back-painted white glass	SSF solid surface	
				FL	RB	FL	RB	FL	RB	PF	FL	RB	
F3C	204	48	(3) 25" bases	10136	13177	10637	12446	12339	14148	24889	30365	23184	27126
F3D	204	54	(3) 25" bases	10670	13871	11197	13101	12989	14893	26197	31961	24403	28552
F3E	204	60	(3) 30" bases	11577	15051	11682	13668	13552	15538	28543	34823	27257	31891
F3F	204	66	(3) 30" bases	13192	17150	13503	15799	15664	17959			29744	34801
F3G	204	72	(3) 30" bases	14099	18329	13987	16365	16225	18603			32220	37698
F4C	210	48	(3) 25" bases	10417	13543	10756	12585	12477	14306	25968	31681	24889	29121
F4D	210	54	(3) 25" bases	10964	14254	11323	13248	13135	15060	27333	33347	26197	30651
F4E	210	60	(3) 30" bases	11927	15506	11834	13846	13728	15740	29814	36374	28825	33726
F4F	210	66	(3) 30" bases	13633	17723	13801	16148	16010	18356			31452	36799
F4G	210	72	(3) 30" bases	14591	18969	14313	16747	16604	19037			34080	39874
F5C	216	48	(3) 25" bases	10594	13773	10935	12794	12685	14544	26145	31897	25067	29329
F5D	216	54	(3) 25" bases	11152	14498	11510	13467	13352	15309	27520	33575	26384	30870
F5E	216	60	(3) 30" bases	12112	15746	12022	14066	13946	15990	30001	36602	29013	33946
F5F	216	66	(3) 30" bases	13821	17968	13988	16366	16227	18605			31640	37019
F5G	216	72	(3) 30" bases	14778	19212	14501	16967	16822	19287			34268	40094
F6C	222	48	(3) 25" bases	11360	14768	11513	13471	13356	15313	27199	33183	26219	30677
F6D	222	54	(3) 25" bases	11957	15545	12120	14181	14060	16120	28630	34929	27598	32290
F6E	222	60	(3) 30" bases	12967	16858	12659	14812	14685	16837	31248	38123	30361	35523
F6F	222	66	(3) 30" bases	14773	19205	14786	17300	17152	19666			32870	38458
F6G	222	72	(3) 30" bases	15784	20520	15323	17928	17775	20380			35960	42074
F7C	228	48	(4) 25" bases	11537	14999	11692	13680	13563	15551	27376	33399	26397	30885
F7D	228	54	(4) 25" bases	12145	15789	12308	14401	14278	16370	28817	35157	27785	32509
F7E	228	60	(4) 30" bases	13155	17102	12848	15033	14904	17088	31437	38354	30548	35742
F7F	228	66	(4) 30" bases	14960	19448	14974	17520	17370	19916			33057	38677
F7G	228	72	(4) 30" bases	15972	20764	15510	18147	17992	20629			36146	42291

specification codes example: QTS-SKU-FLERM01

series	sku	edge	base	grommet location	material + finish code example: PLL 671	top material	top finish
top		FL 1¼" flat PF ½" polished flat RB 1¼" reverse bevel	ER encore	Under Mount see pages 29-31 for location codes Mediatrac1™ see pages 36-46 for location codes 000 none	PLL solid laminate WGL woodgrain laminate ASH ash MPL maple OAK oak WLT walnut PLD paldao GPW glass back-painted white GEW glass etched back-painted white SSF glacier white	see pages 3-5	
Q T S -	-		E R				

radius rectangular top
order bases separately



tops 72" - 120" length x 48" - 60" wide
have one sectional veneer top

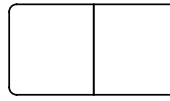

tops 126" - 240" length x 48" - 60" wide
have two sectional veneer tops

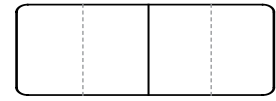

tops 132" - 240" length x 66" - 72" wide
have four sectional veneer tops

sku	l	w	bases to specify	PLL solid laminate WGL woodgrain laminate		ASH ash MPL maple OAK oak WLT walnut		PLD paldao		GPW back-painted white glass	GEW etched back-painted white glass	SSF solid surface	
				FL	RB	FL	RB	FL	RB	PF	FL	RB	
F8C	234	48	(4) 25" bases	11813	15357	11812	13821	13702	15710	28405	34655	27475	32146
F8D	234	54	(4) 25" bases	12434	16165	12433	14547	14423	16536	29898	36476	28920	33837
F8E	234	60	(4) 30" bases	13504	17556	12996	15206	15076	17285	32664	39851	31846	37260
F8F	234	66	(4) 30" bases	15401	20022	15285	17884	17731	20330			34848	40773
F8G	234	72	(4) 30" bases	16465	21405	15851	18546	18388	21082			37767	44188
F9C	240	48	(4) 25" bases	11991	15589	11990	14029	13909	15947	28582	34871	27653	32355
F9D	240	54	(4) 25" bases	12622	16409	12621	14767	14641	16786	30087	36707	29107	34056
F9E	240	60	(4) 30" bases	13691	17799	13182	15423	15292	17533	32850	40077	32035	37481
F9F	240	66	(4) 30" bases	15587	20264	15474	18105	17950	20581			35036	40993
F9G	240	72	(4) 30" bases	16653	21649	16037	18764	18603	21330			37953	44406

specification codes example: QTS-SKU-FLERM01

series	sku	edge
top		FL 1¼" flat PF ½" polished flat RB 1¼" reverse bevel
Q T S -	-	

base	grommet location
ER encore	Under Mount see pages 29-31 for location codes Mediatrac1™ see pages 36-46 for location codes 000 none
E R	

material + finish code example: PLL 671

top material	top finish
PLL solid laminate WGL woodgrain laminate ASH ash MPL maple OAK oak WLT walnut PLD paldao GPW glass back-painted white GEW glass etched back-painted white SSF glacier white	see pages 3-5

arched rectangular top
order bases separately

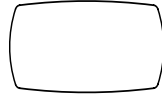

tops 72" - 120" length x 48" - 60" wide
have one sectional veneer top

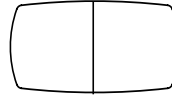

tops 126" - 240" length x 48" - 60" wide
have two sectional veneer tops

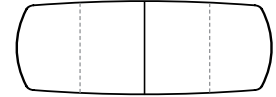

tops 132" - 240" length x 66" - 72" wide
have four sectional veneer tops

sku	l	w	bases to specify	PLL solid laminate		ASH ash		PLD paldao		GPW	GEW	SSF solid surface	
				WGL woodgrain laminate		MPL maple	OAK oak	WLT walnut		back-painted white glass	back-painted white glass	FL	RB
				FL	RB	FL	RB	FL	RB	PF		FL	RB
GGB	72	42/36	(2) 21" bases	3432	4462	5241	6132	6080	6971	10559	12882	8505	9951
GGC	72	48/42	(2) 25" bases	3765	4895	5422	6344	6290	7212	10885	13280	8803	10300
GHB	78	42/36	(2) 21" bases	3627	4716	5369	6282	6229	7141	11124	13572	8948	10470
GHC	78	48/42	(2) 25" bases	3986	5182	5563	6509	6454	7399	11849	14456	9331	10918
GIB	84	42/36	(2) 21" bases	3819	4965	5494	6428	6374	7308	11463	13985	9612	11247
GIC	84	48/42	(2) 25" bases	4209	5472	5700	6669	6612	7581	12385	15110	9834	11506
GJB	90	42/36	(2) 21" bases	4016	5221	5614	6569	6513	7467	12036	14684	10040	11747
GJC	90	48/42	(2) 25" bases	4432	5762	5833	6825	6767	7758	12924	15768	10295	12046
GJD	90	54/48	(2) 25" bases	4849	6304	6055	7085	7024	8054	13964	17037	11390	13327
GKB	96	42/36	(2) 21" bases	4209	5472	5740	6716	6659	7635	12609	15383	10416	12187
GKC	96	48/42	(2) 25" bases	4653	6049	5983	7001	6941	7958	13503	16474	10875	12724
GKD	96	54/48	(2) 25" bases	5101	6632	6219	7277	7215	8272	14614	17830	12044	14092
GKE	96	60/54	(2) 30" bases	5541	7204	6457	7555	7491	8588	15686	19137	13214	15461
GLB	102	42/36	(2) 21" bases	4917	6393	6377	7462	7398	8482	13238	16151	11012	12885
GLC	102	48/42	(2) 25" bases	5388	7005	6628	7755	7689	8816	14032	17120	11474	13425
GLD	102	54/48	(2) 25" bases	5858	7616	6881	8051	7982	9152	15224	18574	12711	14872
GLE	102	60/54	(2) 30" bases	6331	8231	7131	8344	8272	9485	16422	20035	13957	16330
GMB	108	42/36	(2) 21" bases	5108	6641	6525	7635	7569	8679	13750	16775	11711	13702
GMC	108	48/42	(2) 25" bases	5610	7293	6790	7945	7877	9031	14700	17934	12044	14092
GMD	108	54/48	(2) 25" bases	6109	7942	7054	8254	8183	9382	15925	19429	13367	15640
GME	108	60/54	(2) 30" bases	6608	8591	7315	8559	8486	9729	17153	20927	14678	17174

specification codes example: QTS-SKU-FLERM01

series	sku	edge	base
top		FL 1¼" flat PF ½" polished flat RB 1¼" reverse bevel	ER encore
Q T S -	-		E R

grommet location
Under Mount see pages 29-31 for location codes
Mediatrac™ see pages 36-46 for location codes
000 none

material + finish code example: PLL 671

top material	top finish
PLL solid laminate WGL woodgrain laminate ASH ash MPL maple OAK oak WLT walnut PLD paldao GPW glass back-painted white GEW glass etched back-painted white SSF glacier white	see pages 3-5

arched rectangular top
order bases separately

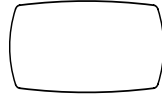

tops 72" - 120" length x 48" - 60" wide
have one sectional veneer top

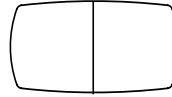

tops 126" - 240" length x 48" - 60" wide
have two sectional veneer tops

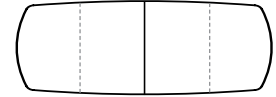

tops 132" - 240" length x 66" - 72" wide
have four sectional veneer tops

sku	l	w	bases to specify	PLL solid laminate WGL woodgrain laminate		ASH ash MPL maple OAK oak WLT walnut		PLD paldao		GPW back-painted white glass	GEW etched back-painted white glass	SSF solid surface	
				FL	RB	FL	RB	FL	RB	PF	FL	RB	
GNB	114	42/36	(2) 21" bases	5304	6896	6671	7806	7739	8873	14281	17423	12258	14342
GNC	114	48/42	(2) 25" bases	5830	7579	6947	8128	8059	9240	15224	18574	12632	14780
GND	114	54/48	(2) 25" bases	6359	8267	7226	8455	8383	9611	16539	20178	14032	16418
GNE	114	60/54	(2) 30" bases	6886	8952	7505	8781	8706	9982	17845	21771	15413	18034
GOB	120	42/36	(2) 21" bases	5496	7145	6819	7979	7911	9070	14944	18232	12838	15021
GOC	120	48/42	(2) 25" bases	6053	7869	7111	8320	8249	9458	15787	19261	13215	15462
GOD	120	54/48	(2) 25" bases	6608	8591	7401	8660	8586	9844	17179	20959	14678	17174
GOE	120	60/54	(2) 30" bases	7163	9312	7658	8960	8884	10186	18572	22658	16131	18874
GOF	120	66/60	(2) 30" bases	8107	10540	8933	10452	10363	11881			16607	19431
GPC	126	48/36	(2) 25" bases	6944	9028	8212	9609	9526	10922	16728	20409	15961	18675
GPD	126	54/48	(2) 25" bases	7310	9503	8539	9991	9906	11357	18264	22283	16295	19066
GPE	126	60/54	(2) 30" bases	7919	10295	8864	10371	10283	11790	19765	24114	17940	20990
GPF	126	66/60	(2) 30" bases	8528	11087	9193	10756	10664	12227			19593	22924
GQC	132	48/36	(3) 25" bases	6886	8952	8400	9828	9744	11172	16915	20637	16150	18896
GQD	132	54/42	(3) 25" bases	7496	9745	8727	10211	10124	11607	18452	22512	16482	19284
GQE	132	60/48	(2) 25", (1) 30" bases	8107	10540	9053	10593	10502	12041	19952	24342	18129	21211
GQF	132	66/54	(2) 25", (1) 30" bases	8716	11331	9381	10976	10882	12477			19780	23143
GRC	138	48/36	(3) 25" bases	7418	9644	8462	9901	9816	11255	18672	22780	16741	19587
GRD	138	54/42	(3) 25" bases	7808	10151	8916	10432	10343	11859	19663	23989	17633	20631
GRE	138	60/48	(2) 25", (1) 30" bases	8474	11017	9274	10851	10758	12335	21319	26010	19441	22746
GRF	138	66/54	(2) 25", (1) 30" bases	9596	12475	10360	12122	12018	13779			21270	24886

specification codes example: QTS-SKU-FLERM01

series	sku	edge	base	grommet location	material + finish code example: PLL 671	top finish
top		FL 1¼" flat PF ½" polished flat RB 1¼" reverse bevel	ER encore	Under Mount see pages 29-31 for location codes Mediatract™ see pages 36-46 for location codes 000 none	PLL solid laminate WGL woodgrain laminate ASH ash MPL maple OAK oak WLT walnut PLD paldao GPW glass back-painted white GEW glass etched back-painted white SSF glacier white	see pages 3-5
Q T S -	-		E R			

arched rectangular top
order bases separately

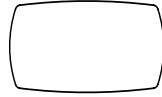

tops 72" - 120" length x 48" - 60" wide
have one sectional veneer top

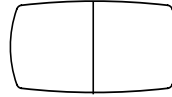

tops 126" - 240" length x 48" - 60" wide
have two sectional veneer tops

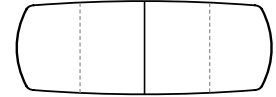

tops 132" - 240" length x 66" - 72" wide
have four sectional veneer tops

sku	l	w	bases to specify	PLL solid laminate WGL woodgrain laminate		ASH ash MPL maple OAK oak WLT walnut		PLD paldao		GPW back-painted white glass	GEW etched back-painted white glass	SSF solid surface	
				FL	RB	FL	RB	FL	RB	PF	FL	RB	
GSD	144	54/42	(3) 25" bases	7994	10393	9105	10653	10562	12110	19851	24219	17820	20850
GSE	144	60/48	(2) 25", (1) 30" bases	8661	11260	9461	11070	10975	12584	21507	26239	19628	22965
GSF	144	66/54	(2) 25", (1) 30" bases	9784	12720	10548	12342	12236	14029			21457	25105
GTD	150	54/42	(3) 25" bases	8309	10802	9233	10803	10711	12280	20960	25572	18999	22229
GTE	150	60/48	(2) 25", (1) 30" bases	9029	11738	9614	11249	11153	12787	22732	27734	20960	24524
GTF	150	66/54	(2) 25", (1) 30" bases	10208	13271	10800	12636	12528	14364			22922	26819
GUD	156	54/42	(3) 25" bases	8495	11044	9420	11022	10928	12529	21148	25801	19186	22448
GUE	156	60/48	(2) 25", (1) 30" bases	9216	11981	9802	11469	11371	13037	22920	27963	21148	24744
GUF	156	66/54	(2) 25", (1) 30" bases	10395	13514	10987	12855	12745	14613			23109	27038
GVD	162	54/42	(3) 25" bases	9320	12116	10035	11741	11641	13347	22242	27136	20277	23725
GVE	162	60/48	(2) 25", (1) 30" bases	10098	13128	10440	12215	12111	13886	24167	29484	22323	26118
GVF	162	66/54	(2) 25", (1) 30" bases	11329	14728	11713	13705	13588	15579			24374	28518
GWD	168	54/42	(3) 25" bases	9507	12360	10224	11963	11860	13598	22428	27363	20464	23943
GWE	168	60/48	(2) 25", (1) 30" bases	10285	13371	10627	12434	12328	14134	24353	29711	22509	26336
GWF	168	66/54	(2) 25", (1) 30" bases	11515	14970	11901	13925	13806	15829			24561	28737
GXD	174	54/42	(3) 25" bases	9819	12765	10348	12108	12004	13763	23468	28631	21592	25263
GXE	174	60/48	(2) 25", (1) 30" bases	10652	13848	10780	12613	12505	14338	25548	31169	23775	27817
GXF	174	66/54	(2) 25", (1) 30" bases	11939	15521	12225	14304	14181	16260			25995	30415
GYD	180	54/42	(3) 25" bases	10005	13007	10536	12328	12222	14013	23655	28860	21779	25482
GYE	180	60/48	(2) 25", (1) 30" bases	10838	14090	10967	12832	12722	14587	25734	31396	23961	28035
GYF	180	66/54	(2) 25", (1) 30" bases	12127	15766	12410	14520	14396	16506			26182	30633

specification codes example: QTS-SKU-FLERM01

series	sku	edge	base	grommet location
top		FL 1¼" flat PF ½" polished flat RB 1¼" reverse bevel	ER encore	Under Mount see pages 29-31 for location codes Mediatrac1™ see pages 36-46 for location codes 000 none
Q T S -	-		E R	

material + finish code example: PLL 671

top material	top finish
PLL solid laminate WGL woodgrain laminate ASH ash MPL maple OAK oak WLT walnut PLD paldao GPW glass back-painted white GEW glass etched back-painted white SSF glacier white	see pages 3-5

arched rectangular top
order bases separately

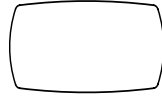

tops 72" - 120" length x 48" - 60" wide
have one sectional veneer top

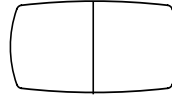

tops 126" - 240" length x 48" - 60" wide
have two sectional veneer tops

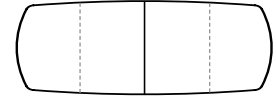

tops 132" - 240" length x 66" - 72" wide
have four sectional veneer tops

sku	l	w	bases to specify	PLL solid laminate WGL woodgrain laminate		ASH ash MPL maple OAK oak WLT walnut		PLD paldao		GPW back-painted white glass	GEW etched back-painted white glass	SSF solid surface	
				FL	RB	FL	RB	FL	RB	PF	FL	RB	
GZD	186	54/42	(3) 25" bases	10318	13414	10766	12597	12489	14319	24781	30233	22896	26789
GZE	186	60/48	(2) 25", (1) 30" bases	11209	14572	11226	13135	13023	14931	26980	32916	25241	29532
GZF	186	66/54	(2) 25", (1) 30" bases	12760	16588	12948	15150	15020	17221			27565	32252
G1D	192	54/42	(3) 25" bases	10506	13658	10954	12817	12707	14569	24969	30463	23082	27006
G1E	192	60/48	(2) 25", (1) 30" bases	11397	14817	11413	13354	13240	15180	27168	33145	25428	29751
G1F	192	66/54	(2) 25", (1) 30" bases	12948	16833	13135	15368	15237	17470			27752	32470
G2D	198	54/42	(3) 25" bases	10820	14066	11080	12964	12853	14737	26009	31731	24217	28334
G2E	198	60/48	(2) 25", (1) 30" bases	11761	15290	11565	13532	13416	15382	28356	34595	27072	31675
G2F	198	66/54	(2) 25", (1) 30" bases	13412	17436	13385	15661	15527	17803			29558	34583
G3D	204	54/42	(3) 25" bases	11006	14308	11266	13182	13069	14984	26197	31961	24403	28552
G3E	204	60/48	(2) 25", (1) 30" bases	11949	15534	11754	13753	13635	15633	28543	34823	27257	31891
G3F	204	66/54	(2) 25", (1) 30" bases	13600	17680	13574	15882	15746	18054			29744	34801
G4D	210	54/42	(3) 25" bases	11319	14715	11393	13330	13216	15153	27333	33347	26197	30651
G4E	210	60/48	(2) 25", (1) 30" bases	12319	16015	11905	13929	13810	15834	29814	36374	28825	33726
G4F	210	66/54	(2) 25", (1) 30" bases	14064	18284	13879	16239	16100	18460			31452	36799
G5D	216	54/42	(3) 25" bases	11506	14958	11581	13550	13434	15403	27520	33575	26384	30870
G5E	216	60/48	(2) 25", (1) 30" bases	12508	16261	12093	14149	14028	16084	30001	36602	29013	33946
G5F	216	66/54	(2) 25", (1) 30" bases	14253	18529	14066	16458	16317	18708			31640	37019
G6D	222	54/42	(3) 25" bases	12329	16028	12196	14270	14148	16221	28630	34929	27598	32290
G6E	222	60/48	(2) 25", (1) 30" bases	13382	17397	12733	14898	14771	16935	31248	38123	30361	35523
G6F	222	66/54	(2) 25", (1) 30" bases	15226	19794	14861	17388	17239	19766			32870	38458

specification codes example: QTS-SKU-FLERM01

series	sku	edge	base	grommet location	material + finish code example: PLL 671	top finish
top		FL 1¼" flat PF ½" polished flat RB 1¼" reverse bevel	ER encore	Under Mount see pages 29-31 for location codes Mediatrac1™ see pages 36-46 for location codes 000 none	top material PLL solid laminate WGL woodgrain laminate ASH ash MPL maple OAK oak WLT walnut PLD paldao GPW glass back-painted white GEW glass etched back-painted white SSF glacier white	see pages 3-5
Q T S -	-		E R			

arched rectangular top
order bases separately

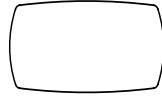

tops 72" - 120" length x 48" - 60" wide
have one sectional veneer top

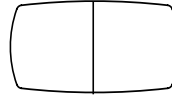

tops 126" - 240" length x 48" - 60" wide
have two sectional veneer tops

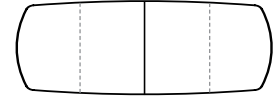

tops 132" - 240" length x 66" - 72" wide
have four sectional veneer tops

sku	l	w	bases to specify	PLL solid laminate WGL woodgrain laminate		ASH ash MPL maple OAK oak WLT walnut		PLD paldao		GPW back-painted white glass	GEW etched back-painted white glass	SSF solid surface	
				FL	RB	FL	RB	FL	RB	PF	FL	RB	
G7D	228	54/42	(2) 25", (2) 30" bases	12515	16270	12383	14489	14365	16470	28817	35157	27785	32509
G7E	228	60/48	(2) 25", (2) 30" bases	13570	17641	12920	15117	14988	17184	31437	38354	30548	35742
G7F	228	66/54	(2) 25", (2) 30" bases	15412	20036	15049	17608	17457	20016			33057	38677
G8D	234	54/42	(2) 25", (2) 30" bases	12827	16676	12511	14638	14513	16640	29898	36476	28920	33837
G8E	234	60/48	(2) 25", (2) 30" bases	13939	18121	13078	15302	15171	17394	32664	39851	31846	37260
G8F	234	66/54	(2) 25", (2) 30" bases	15881	20646	15363	17975	17822	20433			34848	40773
G9D	240	54/42	(2) 25", (2) 30" bases	13014	16919	12699	14858	14731	16890	30087	36707	29107	34056
G9E	240	60/48	(2) 25", (2) 30" bases	14127	18366	13265	15521	15388	17643	32850	40077	32035	37481
G9F	240	66/54	(2) 25", (2) 30" bases	16070	20891	15551	18195	18040	20683			35036	40993

specification codes example: QTS-SKU-FLERM01

series	sku	edge	base	grommet location	material + finish code example: PLL 671	top finish
top		FL 1¼" flat PF ½" polished flat RB 1¼" reverse bevel	ER encore	Under Mount see pages 29-31 for location codes Mediatrac1™ see pages 36-46 for location codes 000 none	PLL solid laminate WGL woodgrain laminate ASH ash MPL maple OAK oak WLT walnut PLD paldao GPW glass back-painted white GEW glass etched back-painted white SSF glacier white	see pages 3-5
Q T S -	-		E R			

teleconference top
order bases separately

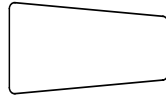

tops 96" - 120" length x 48" - 60" wide
have one sectional veneer top

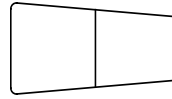

tops 126" - 204" length x 48" - 60" wide
have two sectional veneer tops

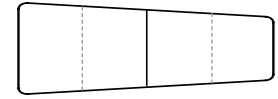

tops 132" - 204" length x 66" - 72" wide
have four sectional veneer tops

sku	l	w	bases to specify	PLL solid laminate WGL woodgrain laminate		ASH ash MPL maple OAK oak WLT walnut		PLD paldao		GPW back-painted white glass	GEW etched back-painted white glass	SSF solid surface	
				FL	RB	FL	RB	FL	RB	PF	FL	RB	
IKD	96	54/36	(1) 25", (1) 30" base	5467	7108	6732	7877	7810	8954	14185	17306	10866	12714
IKE	96	60/42	(1) 25", (1) 30" base	5934	7715	6990	8179	8109	9297	14620	17837	11917	13943
ILD	102	54/36	(1) 25", (1) 30" base	6287	8174	7451	8718	8644	9910	14700	17934	11463	13412
ILE	102	60/42	(1) 25", (1) 30" base	6781	8816	7721	9034	8957	10269	16234	19806	12564	14700
IMD	108	54/36	(1) 25", (1) 30" base	6550	8515	7641	8940	8864	10163	15312	18681	12052	14101
IME	108	60/42	(1) 25", (1) 30" base	7071	9193	7921	9268	9189	10535	17153	20927	13222	15470
IND	114	54/36	(1) 25", (1) 30" base	7196	9355	7832	9164	9086	10417	17004	20745	13801	16148
INE	114	60/42	(1) 25", (1) 30" base	7468	9709	8106	9485	9403	10781	18400	22448	14357	16798
IOD	120	54/36	(1) 25", (1) 30" base	7384	9600	8018	9382	9301	10664	17191	20974	13988	16366
IOE	120	60/42	(1) 25", (1) 30" base	7656	9953	8292	9702	9619	11029	18587	22677	14545	17018
IPD	126	54/36	(1) 25", (1) 30" base	7835	10186	9274	10851	10758	12335	18315	22345	14212	16629
IPE	126	60/42	(1) 25", (1) 30" base	8471	11013	9625	11262	11165	12802	19817	24177	16098	18835
IQD	132	54/36	(2) 25", (1) 30" bases	8022	10429	9461	11070	10975	12584	18502	22573	14400	16848
IQE	132	60/42	(2) 25", (1) 30" bases	8660	11258	9812	11481	11382	13050	20004	24405	16285	19054
IQF	132	66/48	(1) 25", (2) 30" bases	9301	12092	10171	11901	11799	13528			17724	20738
IRD	138	54/36	(2) 25", (1) 30" bases	8602	11183	9564	11190	11095	12721	20253	24709	16542	19355
IRE	138	60/42	(2) 25", (1) 30" bases	9054	11771	10067	11779	11678	13390	21319	26010	17411	20371
IRF	138	66/48	(1) 25", (2) 30" bases	10251	13327	11252	13165	13053	14966			18980	22207
ISE	144	60/42	(2) 25", (1) 30" bases	9241	12014	10255	11999	11896	13640	21507	26239	17599	20591
ISF	144	66/48	(1) 25", (2) 30" bases	10437	13569	11438	13383	13269	15213			19168	22427
ITE	150	60/42	(2) 25", (1) 30" bases	9638	12530	10438	12213	12109	13883	22702	27697	18882	22092
ITF	150	66/48	(1) 25", (2) 30" bases	10890	14157	11730	13725	13607	15601			20586	24086

specification codes example: QTS-SKU-FLERM01

series	sku	edge	base	grommet location	material + finish code example: PLL 671	top material	top finish
top		FL 1¼" flat PF ½" polished flat RB 1¼" reverse bevel	ER encore	Under Mount see pages 29-31 for location codes Mediatrac1™ see pages 36-46 for location codes 000 none	PLL solid laminate WGL woodgrain laminate ASH ash MPL maple OAK oak WLT walnut PLD paldao GPW glass back-painted white GEW glass etched back-painted white SSF glacier white		see pages 3-5
Q T S -	-		E R				

teleconference top
order bases separately

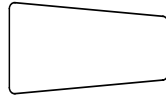

tops 96" - 120" length x 48" - 60" wide
have one sectional veneer top

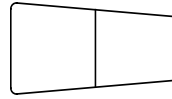

tops 126" - 204" length x 48" - 60" wide
have two sectional veneer tops

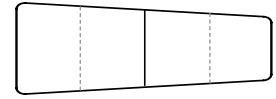

tops 132" - 204" length x 66" - 72" wide
have four sectional veneer tops

sku	l	w	bases to specify	PLL solid laminate WGL woodgrain laminate		ASH ash MPL maple OAK oak WLT walnut		PLD paldao		GPW back-painted white glass	GEW etched back-painted white glass	SSF solid surface	
				FL	RB	FL	RB	FL	RB	PF	FL	RB	
IUE	156	60/42	(2) 25", (1) 30" bases	9826	12774	10625	12432	12325	14132	22890	27926	19070	22312
IUF	156	66/48	(1) 25", (2) 30" bases	11078	14402	11917	13943	13824	15850			20773	24305
IVE	162	60/42	(2) 25", (1) 30" bases	10776	14009	11336	13264	13150	15077	24090	29390	20191	23624
IVF	162	66/48	(1) 25", (2) 30" bases	12085	15711	12722	14885	14758	16921			22033	25779
IWE	168	60/42	(2) 25", (1) 30" bases	10963	14252	11525	13485	13369	15329	24277	29618	20378	23843
IWF	168	66/48	(1) 25", (2) 30" bases	12274	15957	12908	15103	14974	17168			22221	25999
IXE	174	60/42	(2) 25", (1) 30" bases	11360	14768	11704	13694	13577	15567	25482	31089	21507	25164
IXF	174	66/48	(1) 25", (2) 30" bases	12728	16547	13279	15537	15404	17662			23468	27458
IYE	180	60/42	(2) 25", (1) 30" bases	11549	15014	11891	13913	13794	15816	25670	31318	21695	25384
IYF	180	66/48	(1) 25", (2) 30" bases	12915	16790	13465	15755	15620	17909			23655	27677
IZE	186	60/42	(2) 25", (1) 30" bases	11939	15521	12188	14260	14139	16211	26854	32762	23127	27059
IZF	186	66/48	(1) 25", (2) 30" bases	13597	17677	14069	16461	16321	18712			25208	29494
I1E	192	60/42	(2) 25", (1) 30" bases	12127	15766	12376	14480	14357	16461	27043	32993	23315	27279
I1F	192	66/48	(1) 25", (2) 30" bases	13785	17921	14257	16681	16539	18962			25396	29714
I2E	198	60/42	(2) 25", (1) 30" bases	13568	17639	13814	16163	16025	18373			25318	29623
I2F	198	66/48	(1) 25", (2) 30" bases	14283	18568	14540	17012	16867	19339			26649	31180
I3F	204	66/48	(1) 25", (2) 30" bases	14471	18813	14728	17232	17085	19589			26838	31401

specification codes example: QTS-SKU-FLERM01

series	sku	edge	base	grommet location
top		FL 1¼" flat PF ½" polished flat RB 1¼" reverse bevel	ER encore	Under Mount see pages 29-31 for location codes Mediatrac1™ see pages 36-46 for location codes 000 none
Q T S -	-		E R	

material + finish code example: PLL 671

top material	top finish
PLL solid laminate WGL woodgrain laminate ASH ash MPL maple OAK oak WLT walnut PLD paldao GPW glass back-painted white GEW glass etched back-painted white SSF glacier white	see pages 3-5

Under Mount Power

Bernhardt Design offers a proprietary under mount power solution allowing quick and easy daisy chaining of modules together. A maximum of (10) under mount power modules can be connected on one power infeed.

The under mount power modules are available in (2) configurations: (2) receptacles, or (1) receptacle, (1) 2 amp USB-A port and (1) 2 amp USB-C port. Each module in a kit will be provided with the same configuration as specified by the end user.

End user installation will be required per individual SKU. Each SKU includes a separate power infeed with a 10' grounded plug to connect to the power source.

[See installation instructions for installing.](#)

Under mount power is certified to UL STD 962 A CSA STD 22.2 No. 21.

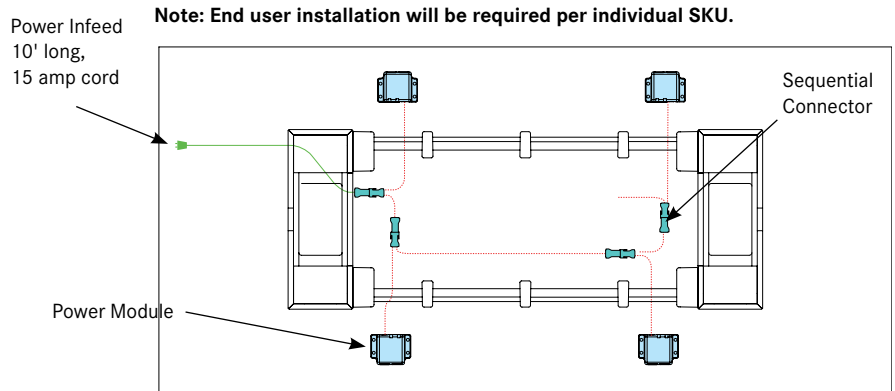

Bernhardt Design provides recommendations for installation locations as shown on page 29-31. Further installation instructions are included with each power unit. Power is specified separately.

Power Modules

Matte Black Finish

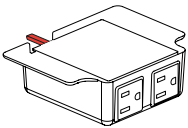

power + power
(2) 15 amp receptacles
120 v 60 Hz.
braided cotton 10' cord
grounded plug
UL 962 listed

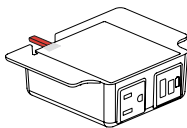

power + usb-a + usb-c
Updated Information Shown in RED
(1) 15 amp receptacle
120 v 60 Hz.
(1) 2 amp USB-A port, 10 watt
(1) 2 amp USB-C port, 20 watt
braided cotton 10' cord
grounded plug
UL 962 listed

Replacement Housing

with Location for Mini AAP Plate

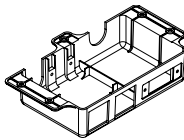

Sequential Connector

Matte Black Finish

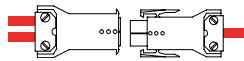

Power Infeed

10' Grounded Plug
Required per individual SKU
Braided Cord

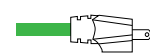

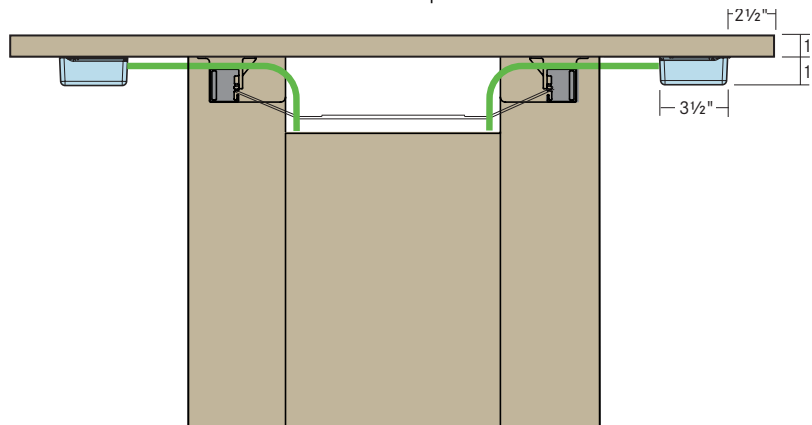

Wire Management

Power infeeds are routed through integral spacers to a multi-wire clip that offers advanced wire management. The following illustration shows a section view of the Encore table with under mount power.

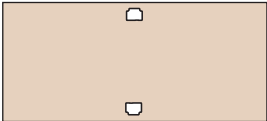
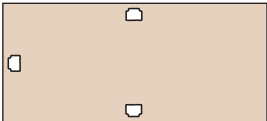

Under mount power kits are specified and sold separately. Each kit lists the table top sizes compatible with the number of power units shown.

All kits include a 10' corded infeed with grounded and fused plug.



# of Kits	sku	specifications	PP power + power	PU power + usb + usb-c
1 Module Kit				
	U01S	72" - 240" Table	\$ 373	\$ 527
				
2 Module Kits				
	U02S	72" - 150" Table	1111	1589
	U02L	156" - 240" Table	1219	1697
				
3 Module Kits				
	U03S	72" - 150" Table	1494	2212
	U03L	156" - 240" Table	1710	2428
				
4 Module Kits				
	U04S	72" - 150" Table	1846	2542
	U04L	156" - 240" Table	2063	2759
				

specification codes example: ACS-SKU-PP

series	sku	power style
PP		power + power
PU		power + usb + usb-c
A C S -	-	

Under mount power kits are specified and sold separately. Each kit lists the table top sizes compatible with the number of power units shown.

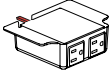
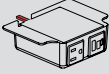
All kits include a 10' corded infeed with grounded and fused plug.

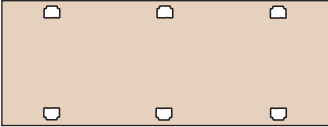
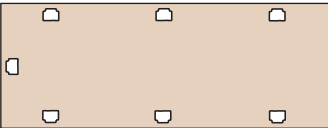
# of Kits	sku	specifications	PP power + power 	PU power + usb + usb-c 
5 Module Kits				
	U05S	72" - 150" Table	\$ 2326	\$ 3379
	U05L	156" - 240" Table 	2542	3596
6 Module Kits				
	U06S	72" - 150" Table	2436	3801
	U06L	156" - 240" Table 	2652	4017
7 Module Kits				
	U07S	72" - 150" Table	2953	4739
	U07L	156" - 240" Table 	3169	4955

specification codes example: ACS-SKU-PP

series	sku	power style
A C S -	-	PP power + power PU power + usb + usb-c





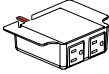
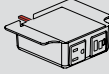
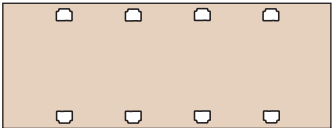
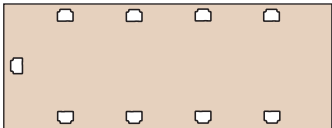
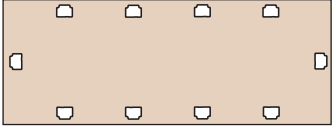

Under mount power kits are specified and sold separately. Each kit lists the table top sizes compatible with the number of power units shown.

All kits include a 10' corded infeed with grounded and fused plug.

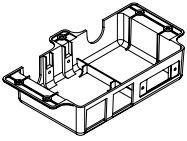
# of Kits	sku	specifications	PP power + power 	PU power + usb + usb-c 
8 Module Kits				
	U08S	60" - 150" Table	\$ 3359	\$ 5676
	U08L	156" - 240" Table 	3575	5892
9 Module Kits				
	U09S	60" - 150" Table	3838	6513
	U09L	156" - 240" Table 	4054	6729
10 Module Kits				
	U10S	72" - 150" Table	4318	7350
	U10L	156" - 240" Table 	4534	7566

specification codes example: ACS-SKU-PP

series	sku	power style
PP		power + power
PU		power + usb + usb-c
A C S -	-	

description	sku	w	d	h	specifications	price
 <p>under mount replacement housing</p> <p>for use with Extron® MAAP installed in the field by end user switch existing housing onsite to this housing to accommodate Extron® MAAP</p>	UPH	7⅜	3¾	1½		\$ 201
 <p>blank plate</p> <p>Extron® MAAP blank plate black powder coat finish single space insert</p>	MP6	2⅛	-	⅝		150
 <p>computer/audio/video mini module</p> <p>Extron® MAAP HDMI female to HDMI female on 10" pigtail single space insert</p>	MP1	2⅛	-	⅝		385
 <p>computer/audio/video mini module</p> <p>Extron® MAAP display port female to display port female on 10" pigtail single space insert</p>	MP3	2⅛	-	⅝		385
 <p>phone/data mini module</p> <p>Extron® MAAP one RJ45 female to punch down leviton CAT6 data single space insert</p>	MP4	2⅛	-	⅝		267
 <p>phone/data mini module</p> <p>Extron® MAAP one RJ45 female to female barrel single space insert</p>	MP5	2⅛	-	⅝		230

specification codes example: ACS-SKU

series	sku
accessories A C S -	

Mediatrac 1™

Mediatrac 1 grommet system is a simplified system for bringing power and data to the meeting table worksurface in a clean simple way.

Mediatrac 1 provides power and various options for Extron AAP data configurations. Grommets are available in (3) different sizes: a 8" x 4" single door unit, a 8" x 8" double door unit and a 8" x 24" double door unit. All units have brushed aluminum trim with options for aluminum, laminate, veneer, corian and glass lids.

Mediatrac 1 has 4 different options for bringing power to the table, corded, harded or 4-trac system with either a corded or hardwired power infeed.

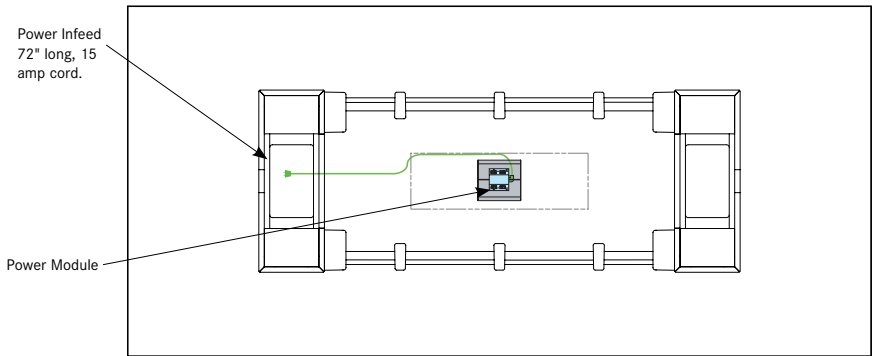

Note: End user installation will be required per individual SKU. Power specified separately. See pages 36-46 for grommet codes.

Mediatrac 1 Options

8" Single Door Mediatrac™ Grommet

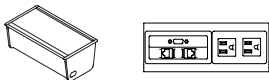

2 grounded outlets, 1 exit plug, accepts 2 Extron single space AAP's, AAP modules specified separately, brushed aluminum frame

8" Double Door Mediatrac™ Grommet

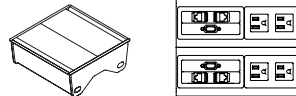

4 grounded outlets, 1 exit plug, accepts 4 Extron single space AAP's, AAP modules specified separately, brushed aluminum frame

24" Double Door Mediatrac™ Grommet

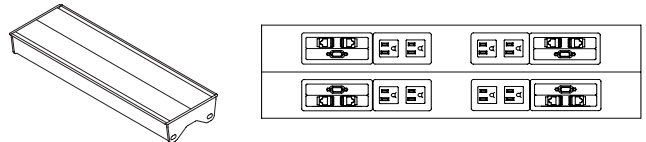

8 grounded outlets, 2 exit plugs, accepts 8 Extron single space AAP's, AAP modules specified separately, brushed aluminum frame

Mediatrac 1 Grommet Kits (Includes the following)

Power Module

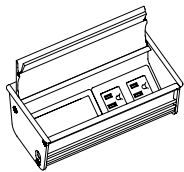

Number and configuration of grommet modules determined by the grommet code

Jumper (if required)



Jumper are determined by the length of the top specified

Connector + H-Block



Will be included in kit when the 4-trac option is specified

Power Infeed Options



72" 4-Trac Power Infeed with 20 amp plug



20 amp receptacle
4-Trac Only



72" 4-Trac Power Infeed with Hardwired

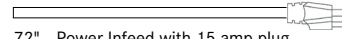

72" Power Infeed with 15 amp plug



15 amp receptacle



72" 3/8" Hardwire Whip

Mediatrac 1 Dimensional Specifications

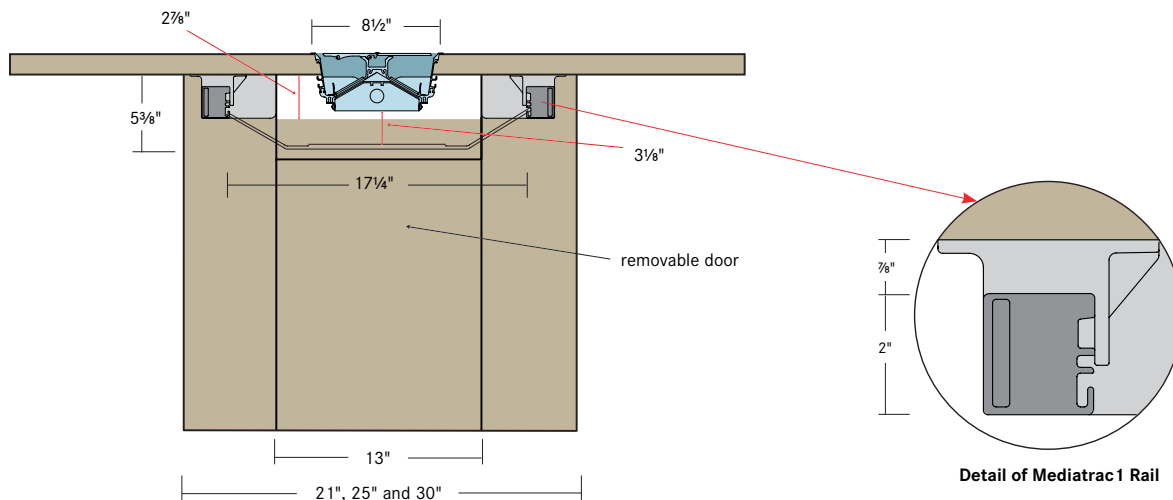

Mediatrac 1 is certified to UL STD 962A, UL STD 1363, CSA STD 22.2 No. 308-14. 4-Trac is certified to UL STD 183 CSA STD 22.2 No. 203.1-14.

Mediatrac 1™ 4-Trac Power System

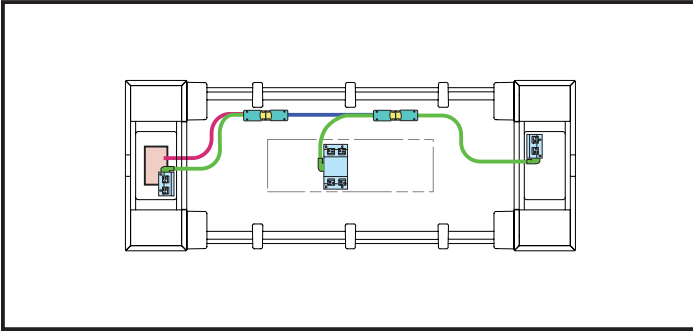

Mediatrac1 is available in our 4-Trac Power System, allowing for easy installation and reconfiguration capabilities.

4-Trac snaps together easily underneath the worksurface using whips from each power module and the integral 4-Trac jumpers specified for use with each particular Mediatrac1 grommet size. **The grommet layout and wiring scheme is specified specifically for each top size and is included with each kit.**

Each power transition is accommodated by an H-Block, which gives the ability to snap together four power leads. Using the provided documentation to facilitate installation, powering the Mediatrac1 system is as easy as snapping together connectors.

Infeeds are available in both hardwired and corded version in a 72" length. The plug version for the Mediatrac1 power system is 20 amps and will require plugging into a 20 amp outlet to comply with electrical codes.

Mediatrac 1 Grommets Using Electrical 4-Trac Power System

- Power Infeed
- Power Module Whip
- Modular Connector
- Jumper
- H-Block
- Power Drop
- Power Module



4-Trac Infeed snaps into an H-Block connected to a Mediatrac1 power module with a 18" modular end.

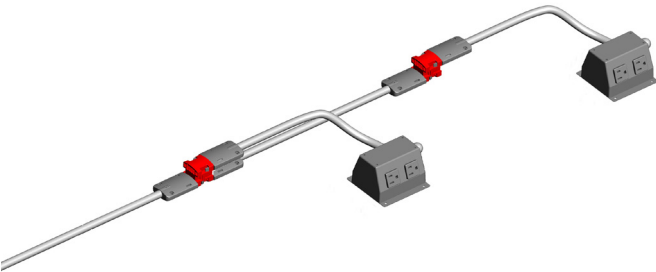

4-Trac H-Block connects up to (4) Jumpers and Power Modules.

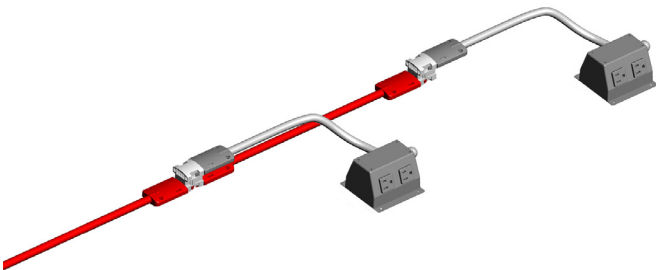

4-Trac Jumpers used in conjunction with the H-Block to wire the system.

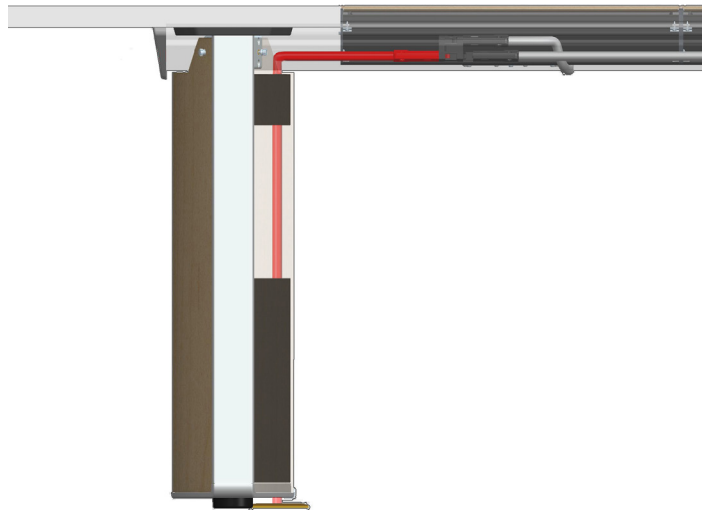

72" 4-Trac Power Infeed with Hardwired Conduit

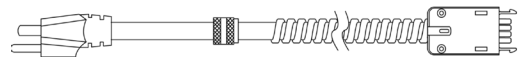

72" 4-Trac Power Infeed with 20 amp Plug



20 amp Receptacle

Illustrations showing electrical 4-Trac power infeed end options – hardwired conduit and 20 amp corded plug. Both are available in 72" lengths. 20 amp receptacle must be used with the plug.

Mediatrac 1™ Grommet Placement Kits

Mediatrac 1™ power options by Bernhardt Design are offered as a grommet kit which includes all grommets, jumpers and necessary components needed to bring power from the floor to the user. The number of grommets and lengths of jumpers are determined by the lengths and power options selected. Your kit will come complete with all necessary parts to install in the field.

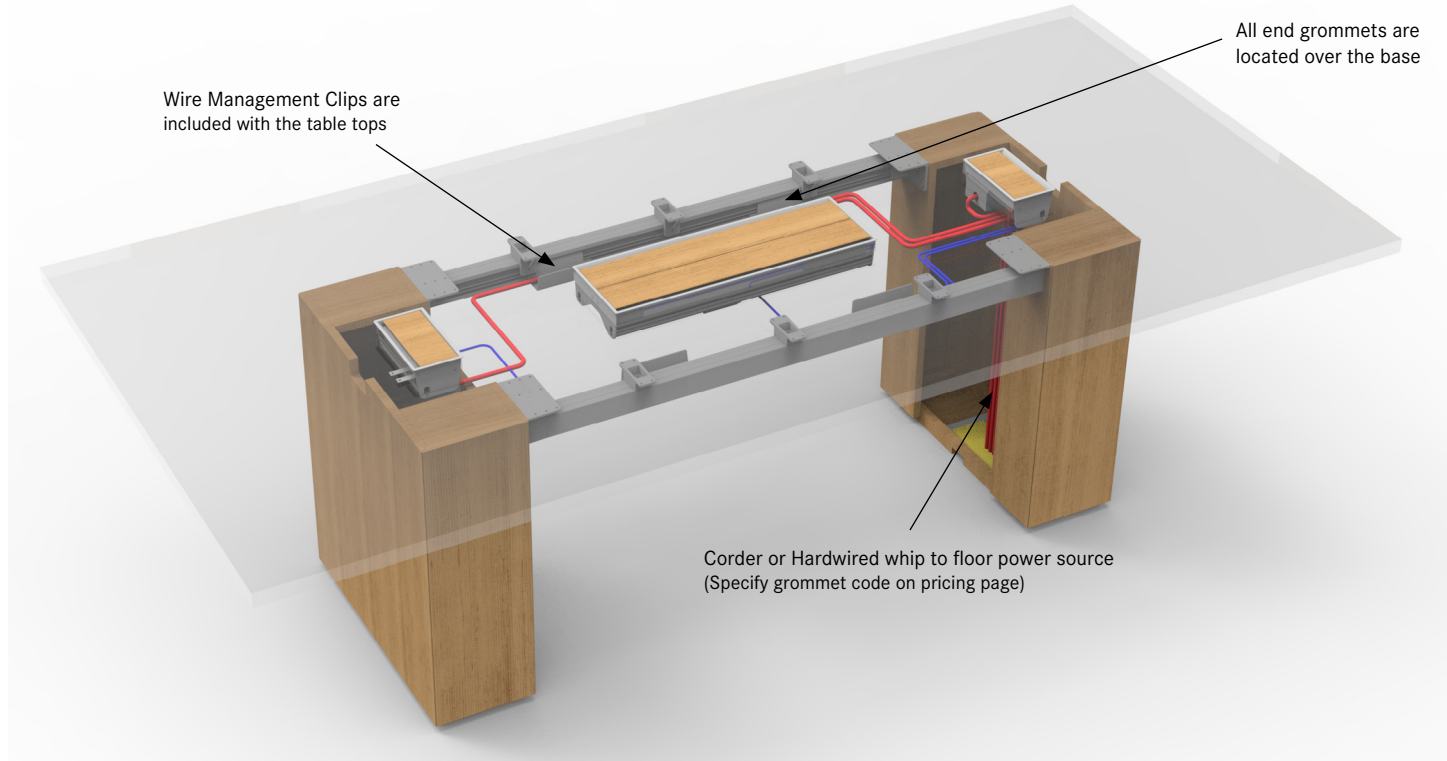

Ordering Mediatrac 1 Grommets

- Determine the amount of power and data needed
- Select the grommet code that best suits your requirements
- Select the type of power infeed you need
- Select the length of table that this is to be used on
(make sure that this grommet code matches the code used when ordering your top)
- Select the grommet trim/frame finish
- Select the lid/door material
- Select the lid/door finish

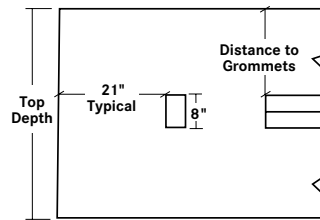

Top Depth	Distance to Grommet
42"	17"
48"	20"
54"	23"
60"	26"
66"	29"
72"	32"

The Grommet Kit will ship separately and will be installed in the field.

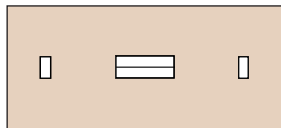

Ordering Example:
120" x 54" Table Top
Walnut veneer, 870 finish
M08 Grommet Code with 4trac corded power
Walnut Door/Brushed Aluminum Trim

specification codes example: MGS-M08-4TC120

series	sku	power option	table length
top		CRD corded	096 150 204
		HWD hardwired	102 156 210
		4TC four trac corded	108 162 216
		4TH four trac hardwired	114 168 222
			120 174 228
			126 180 234
			132 186 224
			138 192
			144 198



M | G | S | - | M | 0 | 8 | - | 4 | T | C | 1 | 2 | 0

material + finish code example: BA WLT 870

frame finish	lid material	lid finish
BA brushed aluminum	ALM aluminum	see pages 3-5
powder coat upcharge \$175	PLL solid laminate	
WH satin white powder coat	WGL woodgrain laminate	
GR graphite powder coat	ASH ash	
BZ bronze powder coat	MPL maple	
IG iron grey powder coat	OAK oak	
RD black red powder coat	WLT walnut	
BK matte black powder coat	PLD paldao	
	SSF glacier white	

B | A | W | L | T | 8 | 7 | 0

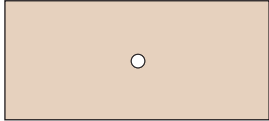
Mediatrac 1 grommet kits and locations codes for veneer, laminates and solid surface tops.
Kits include all jumpers and necessary components based on table length and power option.
Grommet kits ship separately from tops.

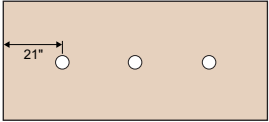
sku	specifications	frame material
M01	72" - 240" Table (1) 3" single round pass through grommet kit 	ALM aluminum \$ 154
M02	72" - 240" Table (2) 3" single round pass through grommet kits 	308
M33	72" - 240" Table (3) 3" single round pass through grommet kits 	462

specification codes example: ACS-SKU



series	sku
top	
A C S -	-

material + finish code example: BA

frame finish
BA brushed aluminum
WH satin white powder coat
GR graphite powder coat
BZ bronze powder coat
IG iron grey powder coat
RD black red powder coat
BK matte black powder coat

Mediatrac1 grommet kits and locations codes for veneer, laminates and solid surface tops.
Kits include all jumpers and necessary components based on table length and power option.
Grommet kits ship separately from tops.

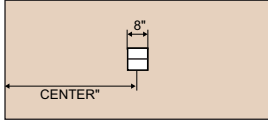
Specify table length, power style, lid material and frame finish below.

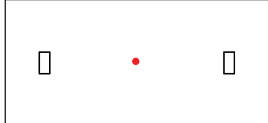
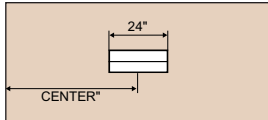
sku	specifications	lid material		
		ALM aluminum	PLL solid laminate WGL woodgrain laminate	ASH ash MPL maple OAK oak WLT walnut PLD paldao SSF solid surface
M03	72" - 240" Table (1) 8" double door mediatrac grommet 	\$ 1999	\$ 2250	\$ 3125
M04	72" - 240" Table (2) 8" single door mediatrac grommets 	2749	2999	5062
P04	72" - 240" Table same information as M04 (1) 1" dia. grommet for microphone 	2875	3125	5186
M06	72" - 240" Table (1) 24" double door mediatrac grommet 	2813	3063	4186

specification codes example: MGS-SKU-CRD132

series	sku	power option	table length		
top		CRD corded	072	132	192
		HWD hardwired	078	138	198
		4TC four trac corded	084	144	204
		4TH four trac hardwired	090	150	210
			096	156	216
			102	162	222
			108	168	228
			114	174	234
			120	180	240

material + finish code example: BA WLT 839

frame finish	lid material	lid finish
BA brushed aluminum	ALM aluminum	see pages 3-5
WH satin white powder coat	PLL solid laminate	
GR graphite powder coat	WGL woodgrain laminate	
BZ bronze powder coat	ASH ash	
IG iron grey powder coat	MPL maple	
RD black red powder coat	OAK oak	
BK matte black powder coat	WLT walnut	
	PLD paldao	
	SSF glacier white	

Mediatrac1 grommet kits and locations codes for veneer, laminates and solid surface tops.
Kits include all jumpers and necessary components based on table length and power option.
Grommet kits ship separately from tops.

Specify table length, power style, lid material and frame finish below.

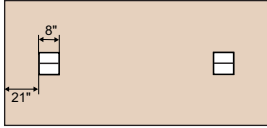
sku	specifications	lid material		
		ALM aluminum	PLL solid laminate WGL woodgrain laminate	ASH ash MPL maple OAK oak WLT walnut PLD paldao SSF solid surface
M05	72" - 240" Table (2) 8" double door mediatrac grommets 	\$ 3624	\$ 3874	\$ 5997
P05	72" - 240" Table same information as M05 (1) 1" dia. grommet for microphone 	3749	3998	6123
M07	84" - 240" Table (1) 8" double door mediatrac grommet (2) 8" single door mediatrac grommets 	4374	4874	7872
M08	84" - 240" Table (1) 24" double door mediatrac grommet (2) 8" single door mediatrac grommets 	5124	5623	8684

specification codes example: MGS-SKU-CRD132

series	sku	power option	table length
top		CRD corded	072 132 192
		HWD hardwired	078 138 198
		4TC four trac corded	084 144 204
		4TH four trac hardwired	090 150 210
			096 156 216
			102 162 222
			108 168 228
			114 174 234
			120 180 240

material + finish code example: BA WLT 839

frame finish	lid material	lid finish
BA brushed aluminum	ALM aluminum	see pages 3-5
powder coat upcharge \$150	PLL solid laminate	
WH satin white powder coat	WGL woodgrain laminate	
GR graphite powder coat	ASH ash	
BZ bronze powder coat	MPL maple	
IG iron grey powder coat	OAK oak	
RD black red powder coat	WLT walnut	
BK matte black powder coat	PLD paldao	
	SSF glacier white	

Mediatrac1 grommet kits and locations codes for veneer, laminates and solid surface tops. Kits include all jumpers and necessary components based on table length and power option. Grommet kits ship separately from tops.

Specify table length, power style, lid material and frame finish below.

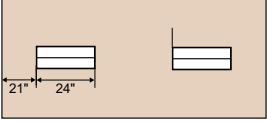
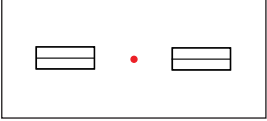
sku	specifications	lid material		
		ALM aluminum	PLL solid laminate WGL woodgrain laminate	ASH ash MPL maple OAK oak WLT walnut PLD paldao SSF solid surface
M12	108" - 240" Table (2) 24" double door mediatrac grommets	\$ 5636	\$ 6135	\$ 7810
				
P12	108" - 240" Table same information as M12 (1) 1" dia. grommet for microphone	5762	6261	7935
				

specification codes example: MGS-SKU-CRD132

series	sku	power option	table length
top		CRD corded	108 162 216
		HWD hardwired	114 168 222
		4TC four trac corded	120 174 228
		4TH four trac hardwired	126 180 234
			132 186 240
			138 192
			144 198
			150 204
			156 210

M | G | S | - | | | | - | | | |

material + finish code example: BA WLT 839

frame finish	lid material	lid finish
BA brushed aluminum	ALM aluminum	see pages 3-5
powder coat upcharge \$150	PLL solid laminate	
WH satin white powder coat	WGL woodgrain laminate	
GR graphite powder coat	ASH ash	
BZ bronze powder coat	MPL maple	
IG iron grey powder coat	OAK oak	
RD black red powder coat	WLT walnut	
BK matte black powder coat	PLD paldao	
	SSF glacier white	

| | | | | | | | | | | | |

Mediatrac1 grommet kits and locations codes for veneer, laminates and solid surface tops. Kits include all jumpers and necessary components based on table length and power option. Grommet kits ship separately from tops.

Specify table length, power style, lid material and frame finish below.

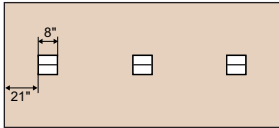
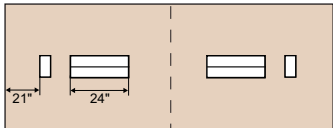
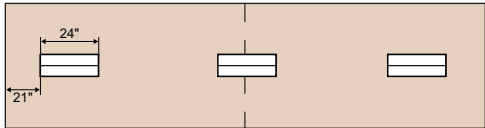
sku	specifications	lid material		
		ALM aluminum	PLL solid laminate WGL woodgrain laminate	ASH ash MPL maple OAK oak WLT walnut PLD paldao SSF solid surface
M10	96" - 240" Table (3) 8" double door mediatrac grommets 	\$ 5436	\$ 5936	\$ 8995
M15	132" - 240" Table (2) 8" single door mediatrac grommets (2) 24" double door mediatrac grommets 	7122	7746	11744
M30	156" - 240" Table (3) 24" double door mediatrac grommets Two power infeeds will be arranged for a power drop located at the center of the table. Complies with UL standards. 	7622	8371	11619

specification codes example: MGS-SKU-CRD132

series	sku	power option	table length
top		CRD corded	096 150 204
		HWD hardwired	102 156 210
		4TC four trac corded	108 162 216
		4TH four trac hardwired	114 168 222
			120 174 228
			126 180 234
			132 186 224
			138 192
			144 198

material + finish code example: BA WLT 839

frame finish	lid material	lid finish
BA brushed aluminum	ALM aluminum	see pages 3-5
powder coat upcharge \$225	PLL solid laminate	
WH satin white powder coat	WGL woodgrain laminate	
GR graphite powder coat	ASH ash	
BZ bronze powder coat	MPL maple	
IG iron grey powder coat	OAK oak	
RD black red powder coat	WLT walnut	
BK matte black powder coat	PLD paldao	
	SSF glacier white	

Mediatrac1 grommet kits and locations codes for veneer, laminates and solid surface tops.
Kits include all jumpers and necessary components based on table length and power option.
Grommet kits ship separately from tops.

Specify table length, power style, lid material and frame finish below.

sku	specifications	lid material		
		ALM aluminum	PLL solid laminate WGL woodgrain laminate	ASH ash MPL maple OAK oak WLT walnut PLD paldao SSF solid surface
M14	132" - 240" Table (4) 8" double door mediatrac grommets 	\$ 7560	\$ 8184	\$ 12557
M21	180" - 240" Table (5) 8" double door mediatrac grommets 	8809	9559	14680
M25	228" - 240" Table (6) 8" double door mediatrac grommets Two power infeeds will be arranged for a power drop located at the center of the table. Complies with UL standards. 	10745	11495	17804

specification codes example: MGS-SKU-CRD132

series	sku	power option	table length		
top		CRD corded	132	174	216
		HWD hardwired	138	180	222
		4TC four trac corded	144	186	228
		4TH four trac hardwired	150	192	234
			156	198	240
			162	204	
			168	210	

material + finish code example: BA WLT 839

frame finish	lid material	lid finish
BA brushed aluminum	ALM aluminum	see pages 3-5
powder coat upcharge \$375	PLL solid laminate	
WH satin white powder coat	WGL woodgrain laminate	
GR graphite powder coat	ASH ash	
BZ bronze powder coat	MPL maple	
IG iron grey powder coat	OAK oak	
RD black red powder coat	WLT walnut	
BK matte black powder coat	PLD paldao	
	SSF glacier white	

Mediatrac 1 grommet kits and locations codes for glass tops.
Kits include all jumpers and necessary components based on table length and power option.
Grommet kits ship separately from tops.

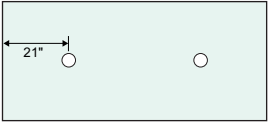
sku	specifications	frame material
01G	72" - 120" Table (1) 3" single round pass through grommet kit for use on 1 piece tops only 	ALM aluminum \$ 154
02G	72" - 120" Table (2) 3" single round pass through grommet kits 	308
33G	72" - 120" Table (3) 3" single round pass through grommet kits 	462

specification codes example: ACS-SKU

series	sku
top	
A C S -	

material + finish code example: BA

frame finish
BA brushed aluminum
WH satin white powder coat
GR graphite powder coat
BZ bronze powder coat
IG iron grey powder coat
RD black red powder coat
BK matte black powder coat

Mediatrac1 grommet kits and locations codes for glass tops.
Kits include all jumpers and necessary components based on table length and power option.
Grommet kits ship separately from tops.

Specify table length, power style, lid material and frame finish below.

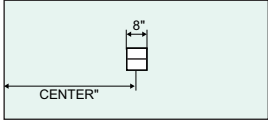
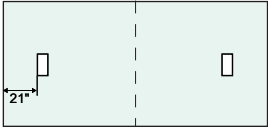
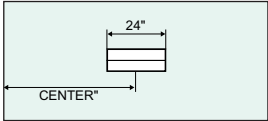
sku	specifications	lid options	
		Aluminum	Glass
03G	72" - 120" Table (1) 8" double door mediatrac grommet for use on 1 piece tops only 	\$ 1999	\$ 3125
04G	72" - 240" Table (1) 24" double door mediatrac grommet 	2749	5062
06G	72" - 120" Table (1) 24" double door mediatrac grommet for use on 1 piece tops only 	2813	4186

specification codes example: MGS-SKU-CRD132

series	sku	power option	table length
top		CRD corded	072 132 192
		HWD hardwired	078 138 198
		4TC four trac corded	084 144 204
		4TH four trac hardwired	090 150 210
			096 156 216
			102 162 222
			108 168 228
			114 174 234
			120 180 240

material + finish code example: BA GPW

frame finish	lid material
BA brushed aluminum	ALM aluminum
WH satin white powder coat	GPW glass back-painted white
GR graphite powder coat	GEW glass etched, back-painted white
BZ bronze powder coat	
IG iron grey powder coat	
RD black red powder coat	
BK matte black powder coat	

Mediatrac1 grommet kits and locations codes for glass tops.
Kits include all jumpers and necessary components based on table length and power option.
Grommet kits ship separately from tops.

Specify table length, power style, lid material and frame finish below.

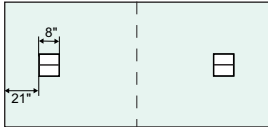
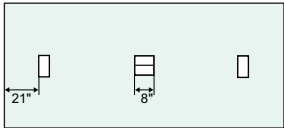
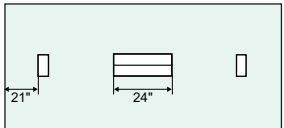
sku	specifications	lid options	
		Aluminum	Glass
05G	72" - 240" Table (2) 8" double door mediatrac grommets 	\$ 3624	\$ 5997
07G	84" - 120" Table (1) 8" double door mediatrac grommet (2) 8" single door mediatrac grommet <i>for use on 1 piece tops only</i> 	4374	7872
08G	84" - 120" Table (1) 24" double door mediatrac grommet (2) 8" single door mediatrac grommets <i>for use on 1 piece tops only</i> 	5124	8684

specification codes example: MGS-SKU-CRD132

series	sku	power option	table length
top		CRD corded	072 132 192
		HWD hardwired	078 138 198
		4TC four trac corded	084 144 204
		4TH four trac hardwired	090 150 210
			096 156 216
			102 162 222
			108 168 228
			114 174 234
			120 180 240

material + finish code example: BA GPW

frame finish	lid material
BA brushed aluminum	ALM aluminum
WH satin white powder coat	GPW glass back-painted white
GR graphite powder coat	GEW glass etched, back-painted white
BZ bronze powder coat	
IG iron grey powder coat	
RD black red powder coat	
BK matte black powder coat	

Mediatrac 1 grommet kits and locations codes for glass tops.
Kits include all jumpers and necessary components based on table length and power option.
Grommet kits ship separately from tops.

Specify table length, power style, lid material and frame finish below.

sku	specifications	lid options	
		Aluminum	Glass
10G	96" - 120" Table (3) 8" double door mediatrac grommets for use on 1 piece tops only	\$ 5436	\$ 8995



specification codes example: MGS-SKU-CRD 120

series	sku	power option	table length
top		CRD corded HWD hardwired 4TC four trac corded 4TH four trac hardwired	096 102 108 114 120
M G S -	-		

material + finish code example: BA GPW

frame finish	lid material
BA brushed aluminum WH satin white powder coat GR graphite powder coat BZ bronze powder coat IG iron grey powder coat RD black red powder coat BK matte black powder coat	ALM aluminum GPW glass back-painted white GEW glass etched, back-painted white

Mediatrac 1 grommet kits and locations codes for glass tops.
Kits include all jumpers and necessary components based on table length and power option.
Grommet kits ship separately from tops.

Specify table length, power style, lid material and frame finish below.

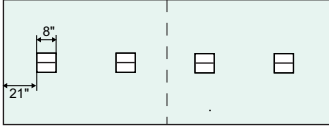

sku	specifications	lid options	
		Aluminum	Glass
14G	132" - 240" Table (4) 8" double door mediatrac grommets 	\$ 7122	\$ 11744

specification codes example: MGS-SKU-CRD 132





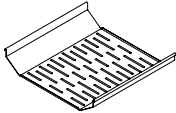
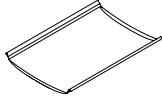

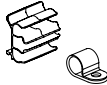
series	sku	power option	table length		
top		CRD corded	132	174	216
		HWD hardwired	138	180	222
		4TC four trac corded	144	186	228
		4TH four trac hardwired	150	192	234
			156	198	240
			162	204	
			168	210	

material + finish code example: BA GPW

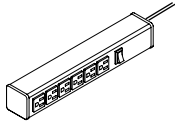

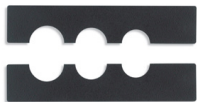

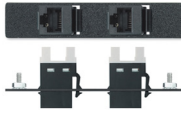

frame finish	lid material
BA brushed aluminum	ALM aluminum
WH satin white powder coat	GPW glass back-painted white
GR graphite powder coat	GEW glass etched, back-painted white
BZ bronze powder coat	
IG iron grey powder coat	
RD black red powder coat	
BK matte black powder coat	

description	sku	w	d	h	price
 <p>equipment tray silver powder coat</p>	VMY	17½	16	3	\$ 295
 <p>cable sling grey nylon mesh material hooks onto mediatrac1™ rails specify with Extron AAP pull-through ACS-VGY</p>	VMW	17½	16	3	295
 <p>wire clip hooks onto mediatrac™ rail smoke polycarbonate finish 4 included with each table at no charge</p>	VNZ	6	2¼	1¾	75
 <p>wire management kit 12 multi wire clips 8 wire clips black</p>	WMK	1 5/8	7/8	1½	201

series	sku
accessories	
A C S -	

description	sku	w	d	h		price
 <p>power strip</p> <p>6 outlet center; 110v 15 amp 15' plug-in cord surge protector UL Listed</p>	VNY	12¼	2	1¾		\$ 546
 <p>blank plate</p> <p>Extron® AAP blank plate with black powder coat finish single space insert</p>	VGG	3½	-	5⁄8		161
 <p>cable pass-through module</p> <p>Extron® AAP single space, cable pass-through plates sold as a set of (2) black powder coat finish</p>	VGY	3½	-	1¾		459
 <p>phone/data module</p> <p>Extron® AAP two RJ-45 pass-through barrels CAT 5e single space insert</p>	VGD	3½	-	5⁄8		346
 <p>phone/data module</p> <p>Extron® AAP one RJ-45 female to punch down block leviton CAT6 data single space insert</p>	V GK	3½	-	5⁄8		277
 <p>phone/data module</p> <p>Extron® AAP two RJ-45 female to punch down block leviton CAT6 data single space insert</p>	V GP	3½	-	5⁄8		384
 <p>phone/data module</p> <p>Extron® AAP two RJ-45 female to punch down block AMP CAT6 data single space insert</p>	V GL	3½	-	5⁄8		384

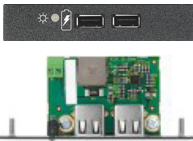
series	sku
accessories	
A C S -	

	description	sku	w	d	h	price
	phone/data module Extron® AAP two RJ-45 female to punch down block higher than CAT6 data type connectors systemax MGS500 backward compatible double space insert	VGQ	3½	-	1⅜	\$ 523
	computer/audio/video module Extron® AAP HDMI female to HDMI female on 10" pigtail single space insert	VG3	3½	-	⅝	384
	control/computer module Extron® AAP two USB A female to female barrels single space insert	VGR	3½	-	⅝	384
	power plate charging module type 5 VDC USB C power outlet 3 A/45 watts type 5 VDC USB A power outlet 2.1A/10.5 watts of power for charging mobile devices, single space insert	VG9	3½	-	⅝	1316
	usb charging module Extron® AAP Power Plate charging module 2 5 VCD USB power outlets 2.1 A / 10.5 watts of power for charging mobile devices single space insert	VGU	3½	-	⅝	746
	computer/audio/video module Extron® SuperPlate 110 - HDMI/DisplayPort/Stereo Audio/USB HDMI: female to female, 10" (25 cm) pigtail DisplayPort: female to female, 10" (25 cm) pigtail Stereo/Audio: 3.5 mm mini jack to captive screw, 10" (25 cm) pigtail USB A: female to female, 10" (25 cm) pigtail double space insert	VG6	3½	-	1⅝	610

series	sku
accessories	
A C S -	

Prices and Specifications

Prices and specifications are subject to change without notice. All prices quoted will be FOB our factories. If applicable, sales tax will be based on ship-to destination.

Bernhardt Design reserves the right to make changes in dimensions, construction, price lists, or product literature without prior notice.

All measurements and weights are approximate and subject to change without notice.

Order Entry

All orders are subject to final acceptance by Bernhardt Design in Lenoir, NC. Receipt of our acknowledgment indicates acceptance of your order subject to the terms set forth on the acknowledgment.

Bernhardt Design attempts to clarify all purchase orders. However, in the event the price list number and description on the purchase order differ, the price list number will prevail.

Changes/Cancellation

All orders in production are considered firm orders and are not subject to changes or cancellation.

Shipping

Bernhardt Design will ship in accordance with customer instructions whenever possible. For convenience, Bernhardt Design offers a guaranteed freight program (GFP). Bernhardt Design will exercise our best judgment in selecting a carrier under our GFP. When selecting a carrier, Bernhardt Design will make our best effort to meet requested delivery dates.

Transportation lead-times and delays including equipment problems, weather, general traffic, traffic accidents, customer warehouse space, labor disputes, customer changes, etc., that occur on a carrier will not be the responsibility of Bernhardt Design. Furthermore, Bernhardt Design will not be responsible for additional costs incurred due to aforementioned delays.

For customers who decline our GFP, Bernhardt Design will stage orders for pick up at 1% of the list price, or \$75 minimum.

Customer orders in production will be shipped as scheduled and will not be held. Bernhardt Design reserves the right to make partial shipments on any order, unless notified otherwise by the customer.

High quality cartoning meeting trucking and railroad specifications is standard at no extra charge. Some items may be blanket wrapped for shipment.

Freight Damage and Claims

Bernhardt Design is not liable for any damages to products that occur during transit or storage. The carrier assumes all responsibility upon acceptance of product. It is the customer's responsibility to inspect products upon receipt and file any claims with the carrier. No product should be refused. If products are received damaged, a written exception should be made on the bill of lading and an immediate inspection be requested of the carrier.

Concealed damage must be reported to the carrier within 10 business days from date of delivery. Failure to make claims shall constitute acceptance of the products and waiver any claims of defects, errors or shortages.

In the event delivery is made on a Bernhardt Design truck, the products should be carefully inspected for transit damage. If contents are damaged, the driver should be notified to call his dispatcher for immediate disposition.

Concealed damage must be reported within 10 business days from date of delivery and product/package held for inspection by a Bernhardt Design representative. Replacements for product damaged in shipment or storage will be manufactured upon receipt of a purchase order.

Returns

No merchandise may be returned to Bernhardt Design without written consent in the form of a Return Authorization from our Quality Assurance Department stating why item is being returned and how item will be shipped.

Unauthorized returns will be automatically refused by our receiving department as well as returns not in accordance with Bernhardt Design shipping instructions. Liability for defective merchandise shall be limited to the replacement or repair of that merchandise, and Bernhardt Design shall not be liable for other damages or losses.

Terms and Credit

Pricing and terms of sale apply to orders accepted by Bernhardt Design, and no terms, stipulations, or conditions contained in the dealer's submitted purchase orders shall have any force or effect. Bernhardt Design requires a completed and signed credit application from every dealer. Bernhardt Design also requires dealers to provide a Blanket Certificate of Resale/Use containing valid sales tax exemption number(s) for their respective state(s).

If credit has been approved, the standard terms for all Bernhardt Design products are Net 30 from the invoice date. In certain instances, as an additional condition of order acceptance, buyer may be required to provide a deposit at time of order and/or remit the balance before shipment is released. If credit has not been approved, a 100% prepayment, including any freight charges, is required prior to production.

Acceptable forms of payment include a certified check or electronic bank transfer. For information on where to send check/electronic bank information contact our Financial Services Department. If a dealer or company check is submitted, three (3) weeks should be allowed for the clearance of the check. If electronic bank transfer is submitted, one (1) week should be allowed for the clearance of the electronic bank transfer. The order is subject to cancellation if payment in full is not received within three (3) weeks from the acknowledgment date.

The dealer may not make deductions for advertising, promotions, quality problems, freight, or any other reason without prior authorization by Bernhardt Design. Such a deduction could result in the curtailment or suspension of further shipments until the matter is resolved. Delinquency notices are generated and mailed periodically. Service charges of 18% per annum will be added to each past-due transaction. Unpaid service charges

will be accrued and invoiced on a periodic basis. Past-due notices may result in orders being held until the situation is resolved. This credit hold could prevent orders from being placed into production or shipped. Orders not in production that are placed on credit hold for three (3) weeks will be subject to cancellation.

Severe past-due situations may result in the employment of a collection agency or other collection litigation. If any collection activity is necessary regarding a dealer account, the dealer will be responsible for the payment of any and all attorney and collection agency fees.

A slow payment history may result in reducing or eliminating an open line of credit. At the discretion of Bernhardt Design, amounts owed by a dealer to Bernhardt Design arising from any transaction or dealings between the dealer and Bernhardt Design may be offset against any amounts owed to the dealer by Bernhardt Design.

Warranty

Bernhardt Design will repair or replace, at its discretion, any product or part thereof which fails as the result of defects in material and workmanship, under single shift use and normal care for five years from date of shipment. This warranty shall apply only to the original purchaser.

This warranty does not cover normal wear and tear, misuse or abuse of product, dramatic temperature changes, exposure to unusual conditions or damages incurred by contact with seating products, tables, desks or other surfaces. Natural color changes, variations or movements in lumber or veneer products, exposure to extreme temperature changes and direct sunlight may cause color changes and/or surface damage. These are circumstances beyond the control of Bernhardt Design and are not warranty issues. Repair or replacement of discontinued product will be at the discretion of Bernhardt Design.

This warranty is the customer's exclusive remedy for product defect and does not apply to damage caused by a freight carrier, dealer, installer, user modification, attachments to a product, or any third party. Bernhardt Design has the exclusive right to make the final determination of product misuse or abuse. Except as stated above, Bernhardt Design makes no express or implied warranties as to any product, and in particular, makes no warranty of merchant ability or of fitness for any particular purpose. Bernhardt Design shall not be liable for any consequential or incidental damages or for commercial loss arising from any product defect.

Operational Parts Warranty

Drawer glides, drawer boxes, drawer pulls, and lock mechanisms have a Life-Time Warranty for original purchaser. Power and communication components are warranted for one year.

Parts Order

Bernhardt Design parts have a \$25 net minimum per order. This does not include freight costs.

Custom Design

Bernhardt Design may alter products to meet specific needs. Contact your local sales representative when a custom design is needed. Custom designs,

if approved, require minimum quantities, additional leadtime and upcharges. A custom job number, available from your Bernhardt Design sales representative, must be submitted with purchase orders.

Orders combining custom design with standard product cannot be scheduled for production until custom items are approved. Custom design orders are not subject to revision or cancellation after acknowledgment.

Wood Finishes

Bernhardt Design tables are available in finishes that are compatible with credenzas and seating finishes. However, finishes on tables may vary slightly from those on seating due to the natural characteristics of the wood. No absolute match is implied or guaranteed.

Light Finishes

Bernhardt Design offers lighter finishes on certain veneers and solid woods. When specifying light finishes the natural characteristics of the wood will be visible and color will vary.

Natural characteristics include the natural discolorations of the wood substance and color variations in glued up stock. These natural characteristics are not considered defects by Bernhardt Design, and therefore merchandise will not be replaced.

Special Finishes

Special finishes, made to customer specifications and subject to factory approval, may be available at a **10% net upcharge with a \$500 net minimum**.

Additional leadtime may be required for special finish items. Special finish orders will not be acknowledged until the special finish sample is approved in writing and received by Bernhardt Design Customer Service. Special finish orders are not subject to revision or cancellation after acknowledgment.

Installation and Maintenance

All freestanding tables and credenzas are equipped with leveling devices. Local floor conditions vary, and it is always necessary to properly adjust leveling devices. Proper leveling is essential to the alignment and function of doors and drawers.

Improperly leveled units result in misaligned doors and drawers and may impair locking mechanisms or other functional hardware.

After the initial installation of credenzas, it may be necessary to readjust and align the units to compensate for settling. This should be expected as a matter of routine maintenance and follow-up to assure proper case function.

Proper installation of Bernhardt Design tables and credenzas is the responsibility of the dealer. Improperly installed units can result in permanent damage to case components. Damage due to improperly installed furniture not covered under product warranty.

Orders combining custom design with standard product cannot be scheduled for production until custom items are approved. Custom design orders are not subject to revision or cancellation after acknowledgment.

Care and Cleaning

Finished wood surfaces should be cleaned with a soft damp cloth, wiping in the direction of the grain. Furniture should be buffed dry immediately with a soft cloth.

Design and Patent Rights

All of the products shown in Bernhardt Design catalogs and described in Bernhardt Design price lists are, and remain, the property of Bernhardt Design, with the sole right reserved to manufacture and to distribute.

Some of the product designs shown are patented in the United States and will remain the property of Bernhardt Design. Any reproduction of the products constitutes an infringement of patented copyright laws and will be subject to prosecution.

Environmental

Some tables and credenzas are LEVEL® for ANSI/BIFMA e3-2019 – Furniture Sustainability Standard and SCS Indoor Advantage™ Gold certified. Visit the product page at bernhardtdesign.com for certifications.

Preferred Carrier Guaranteed Freight Rates

Freight charges will be applied to orders as a separate line item based on the zones listed. Rates are based on zones with a minimum for each zone. All zones are located within the Continental United States.

The freight amount is calculated on the total merchandise list COM price. Additional freight fuel surcharges may apply. Rates are based on deliveries made Monday through Friday, 8 am until 5 pm.

All orders are shipped by Bernhardt Design company trucks or preferred carriers specified by Bernhardt Design. **If a purchase order does not specify that the product must ship complete, Bernhardt Design reserves the right to select the most effective shipping method necessary, including split shipments.** Dealer warehouse information, including phone number and contact name, must be specified on the purchase order.

Zone	Percent	Minimum
Zone 1	3%	\$150
Zone 2	4%	\$150
Zone 3	5%	\$150
Zone 4	5.5%	\$150
Zone 5	6%	\$150

Percent bases on List Price.

Direct site deliveries may be requested with an additional freight cost. Requests for direct site deliveries must be made 2 weeks prior to the scheduled ship week and meet the following criteria:

- Minimum of half truckload
- Delivery site accessible by a 53' trailer
- Complete delivery site address with contact name and on-site phone number
- Labor available for unloading

Deliveries that do not meet the criteria must be directed to a receiver warehouse. If a receiver warehouse is not available, the dealer may make arrangements with their own 3rd party carrier. If a 3rd party carrier is elected, a contact name, phone number and e-mail address is required.

Bernhardt Design has a no touch freight policy. Drivers are not allowed to unload freight.

Weekend direct site deliveries will incur a \$500 per trailer weekend delivery fee. Weekend is defined as between 5 pm Friday and 8 am Monday.

Customers who decline GFP should refer to the shipping section of the Terms and Conditions page.

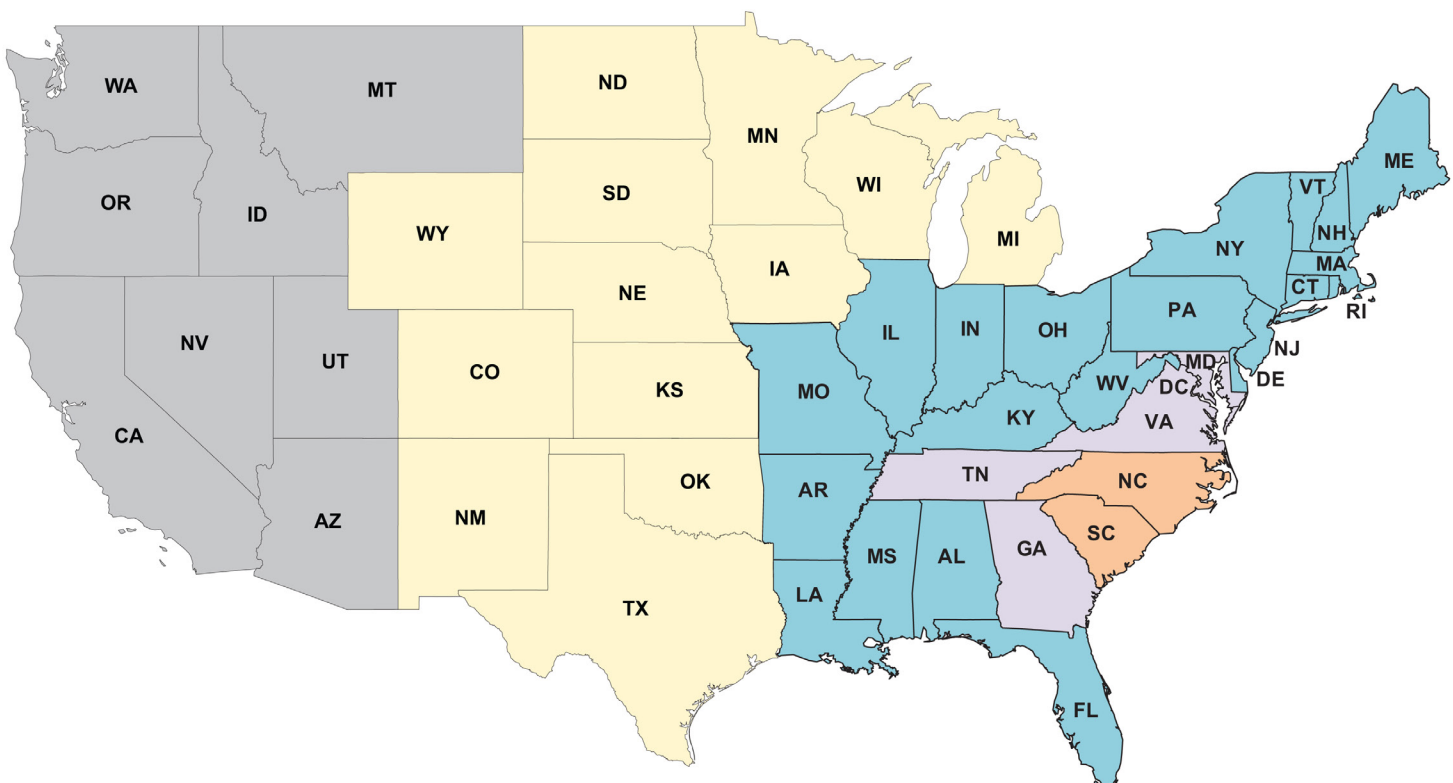

Preferred Carrier Guaranteed Freight Rates - Canada

Freight charges will be applied to orders as a separate line item based on the zones listed. Rates are based on zones with a minimum for each zone.

The freight amount is calculated on the total merchandise list COM price. Additional freight fuel surcharges may apply. Rates are based on deliveries made Monday through Friday, 8 am until 5 pm.

All orders are shipped by Bernhardt Design company trucks or preferred carriers specified by Bernhardt Design. If a purchase order does not specify that the product must ship complete, Bernhardt Design reserves the right to select the most effective shipping method necessary, including split shipments. Dealer warehouse information, including phone number and contact name, must be specified on the purchase order.

Direct site deliveries may be requested with an additional freight cost. Requests for direct site deliveries must be made 2 weeks prior to the scheduled ship week and meet the following criteria:

- Minimum of half truckload
- Delivery site accessible by a 53' trailer
- Complete delivery site address with contact name and on-site phone number
- Labor available for unloading

Deliveries that do not meet the criteria must be directed to a receiver warehouse. If a receiver warehouse is not available, the dealer may make arrangements with their own 3rd party carrier. If a 3rd party carrier is elected, a contact name, phone number and e-mail address is required.

Bernhardt Design has a no touch freight policy. Drivers are not allowed to unload freight.

Weekend direct site deliveries will incur a \$500 per trailer weekend delivery fee. Weekend is defined as between 5 pm Friday and 8 am Monday.

Customers who decline GFP should refer to the shipping section of the Terms and Conditions page.

Zone	Minimums	Freight	Avg. Bus. Days
Zone 1	\$200	5%	10-15
Zone 2	\$200	9%	10-15
Zone 3	\$200	8%	10-15
Zone 4	\$200	11%	10-15
Zone 5	Quote	Quote	

The attached rates are strictly freight and do not include brokerage fees.

