

SPECIFICATIONS

Universal Base (DQP100):

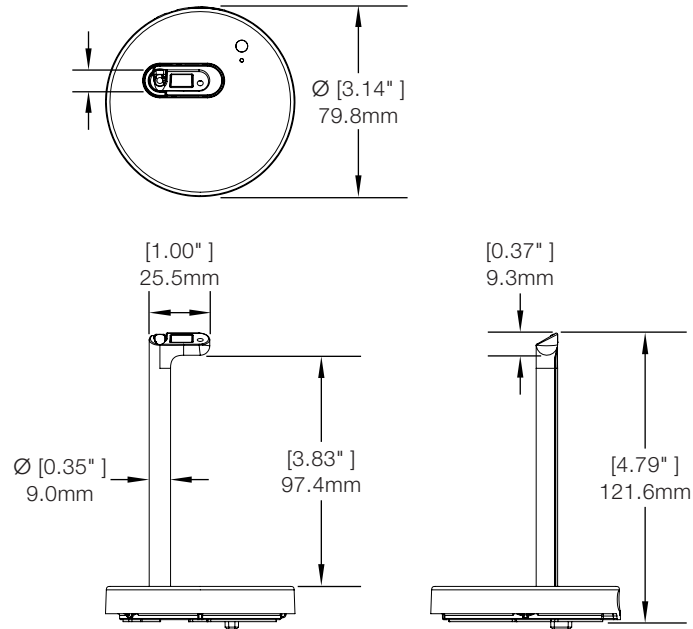

Qi2 Charge Head (DQP200):

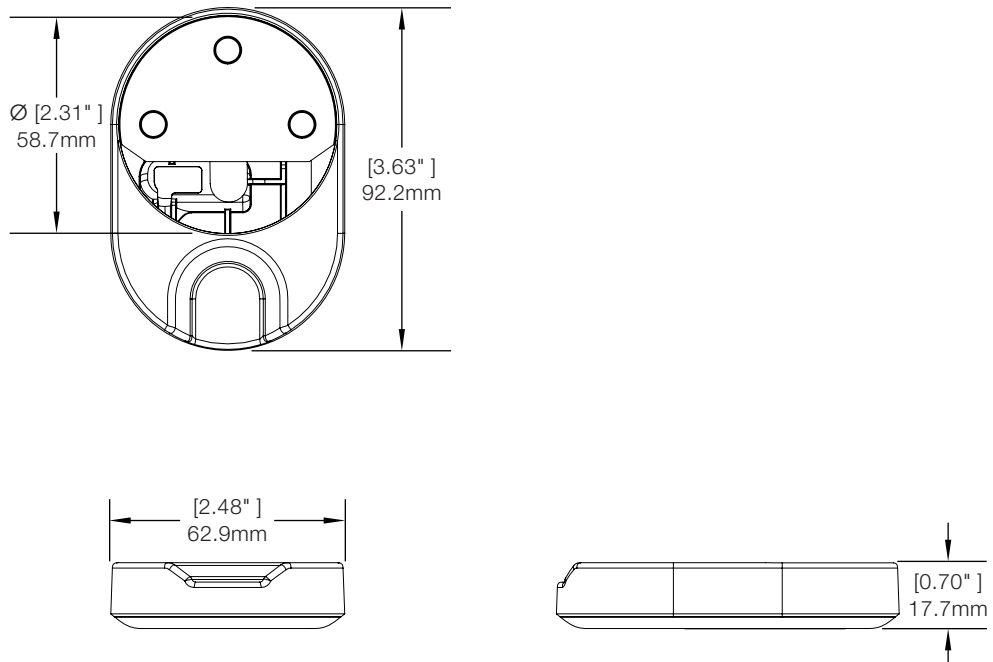

SPECIFICATIONS

Handheld Sensor (DQP300):

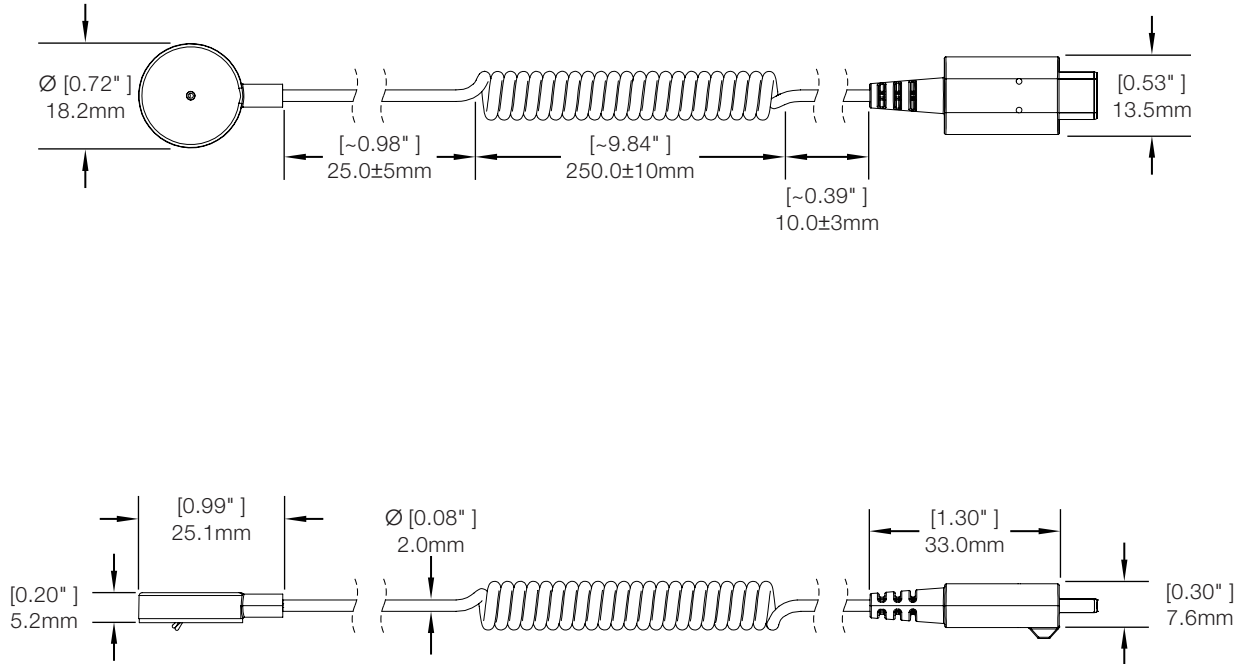

Handheld Sensor Placement Tool (DQP400):

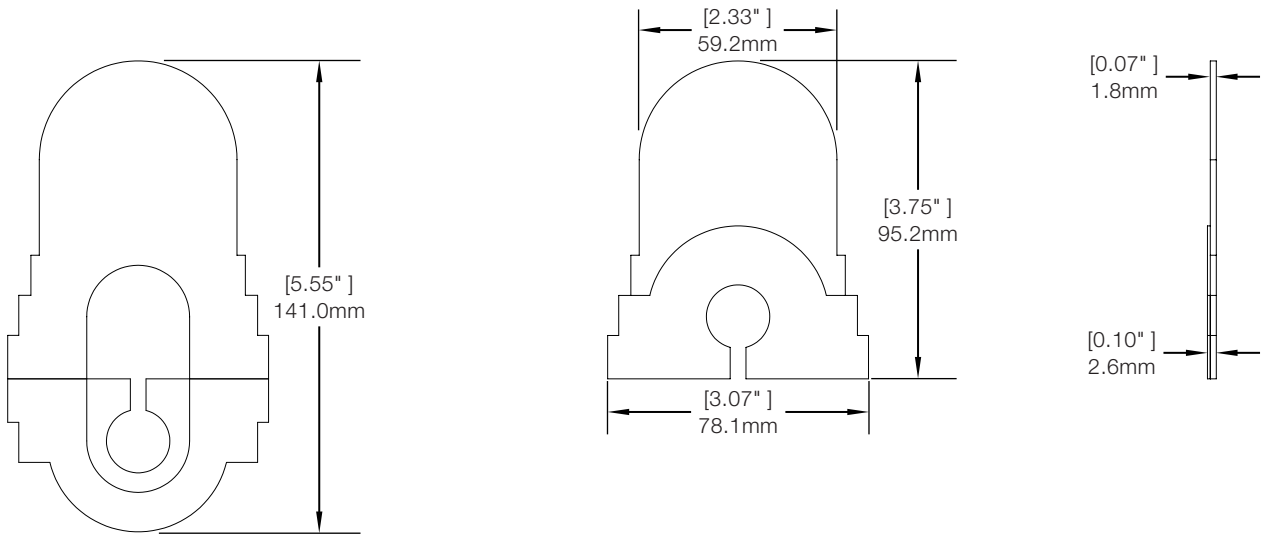

SPECIFICATIONS

Handheld Qi2 Charger (PS552):

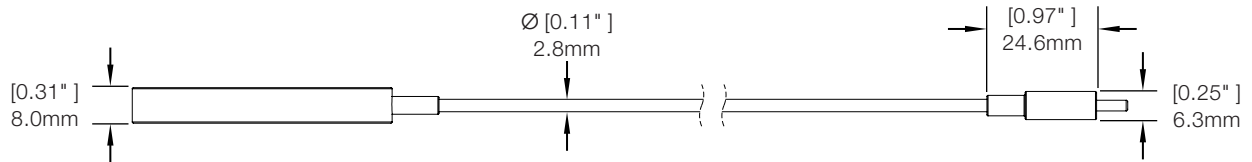
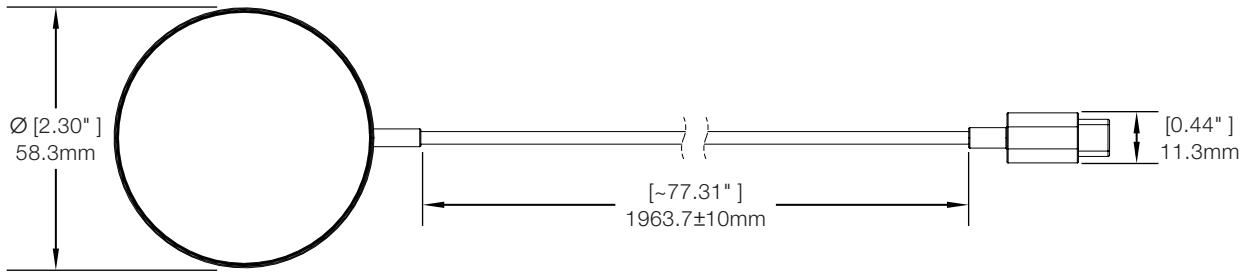

USB-C PD Power Supply (PS520):

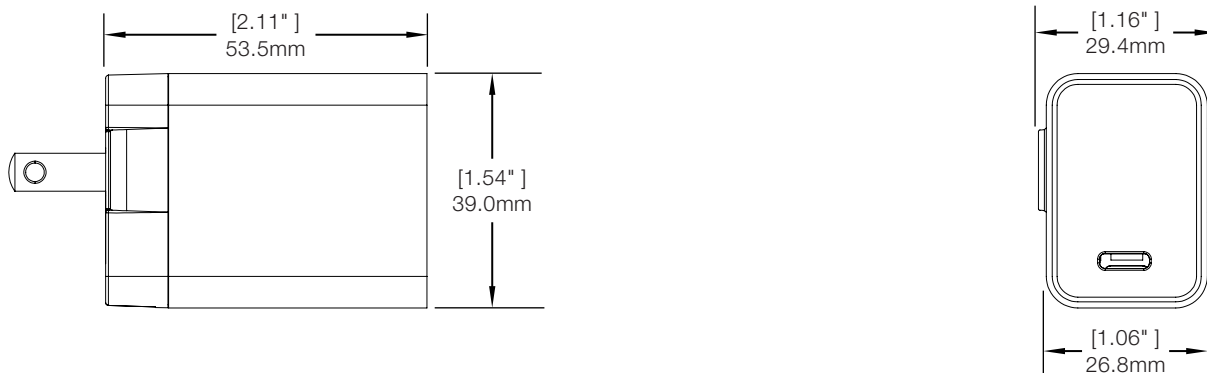

PRODUCT ORDERING

ORDER CODE	DESCRIPTION	NOTES
Handheld Components		
DQP100-W	Universal Base	
DQP200-W	Qi2 Charge Head	
DQP300-W	Handheld Sensor	
DQP400	Handheld Sensor Placement Tool	Pack of 2
PS520-AUS	USB-C PD Power Supply with AUS Plug	
PS520-EU	USB-C PD Power Supply with EU Plug	
PS520-IND	USB-C PD Power Supply with IND Plug	
PS520-UK	USB-C PD Power Supply with UK Plug	
PS520-US	USB-C PD Power Supply with US/JPN Plug	
PS552	Handheld Qi2 Charger	
ADH2333	Clear Adhesive LSE Kit	Pack of 3
ADH2337	MagStand Handheld Charger Replacement Adhesives	Pack of 6
ADH2338	MagStand Base Replacement Adhesive Kit	Pack of 6
ADH2339	MagStand Sensor Replacement Adhesives	Pack of 8
DQD405	Screw Mounting Kit	

invue.com

©2025 InVue Security Products. No endorsement of InVue products has been made by any of the manufacturers of the products shown. Product is sold pursuant to InVue's warranty which can be found at www.invue.com/warranty.

THE AMERICAS 704.752.6513 • 888.55.INVUE

EUROPE, MIDDLE EAST & AFRICA +31.23.8900150

ASIA PACIFIC +852.3127.6811

