

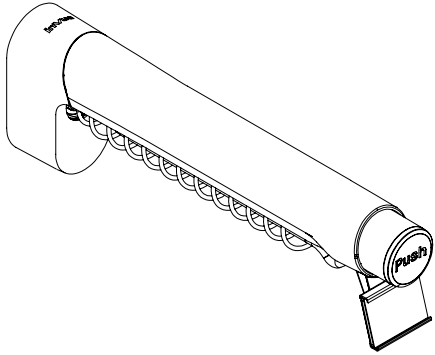

T1000
Anti-Sweep Dispenser, 12" Hangbar
with Insert
T1040, T1041, T1042, T1046-INS

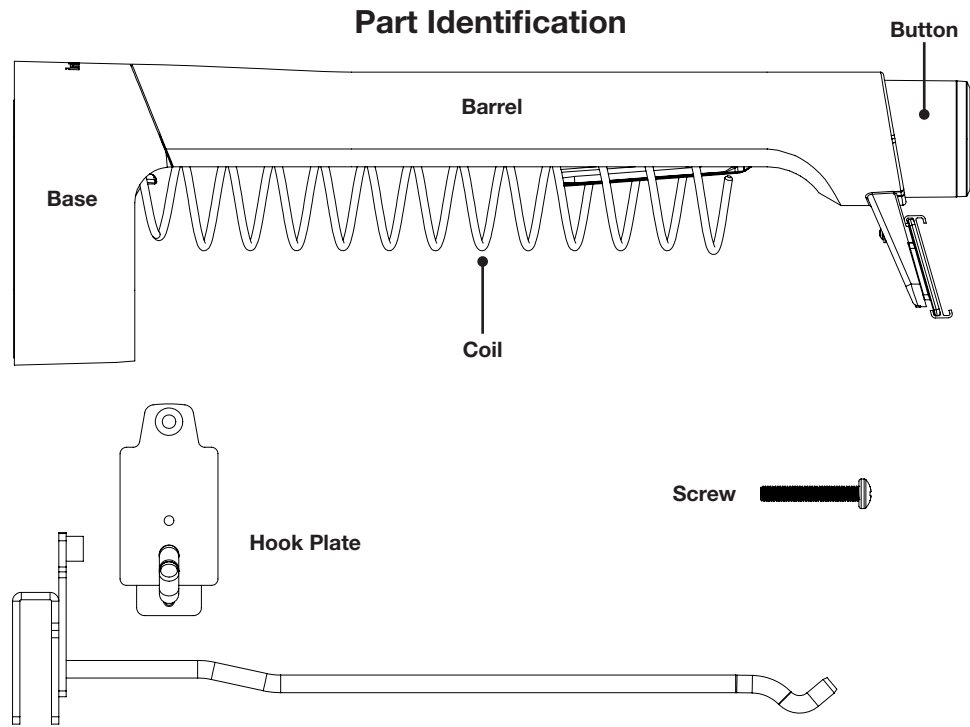

Part Identification



1a Insert the metal tang through the hole in the hangbar. Make sure that it is inserted all the way through the bar.

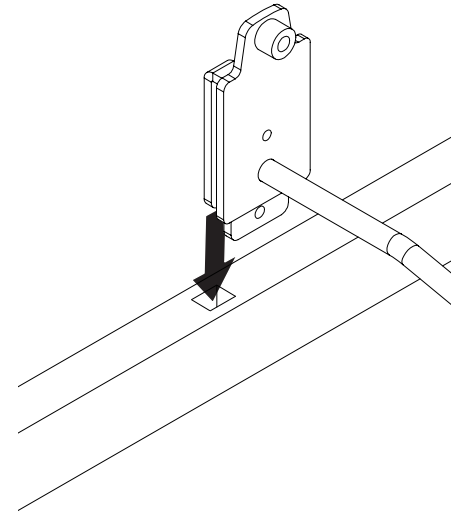

1b Install the screw to secure the mounting bracket to the hang bar.

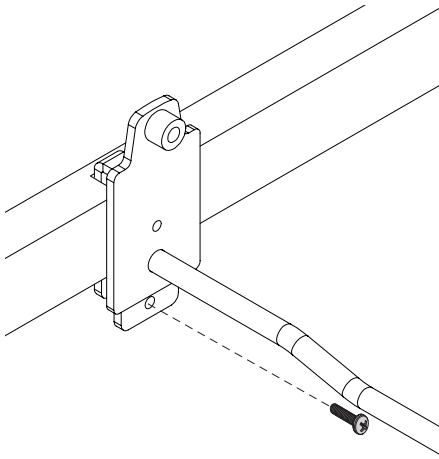

2 Hold the rear housing in one hand and slide the barrel several inches away from the rear housing.
Hold the barrel in place.
Note: Insert the sensor removal multitool attachment (AF6313) into the slot on the top of the T1000. If not available, hold it in place by hand.

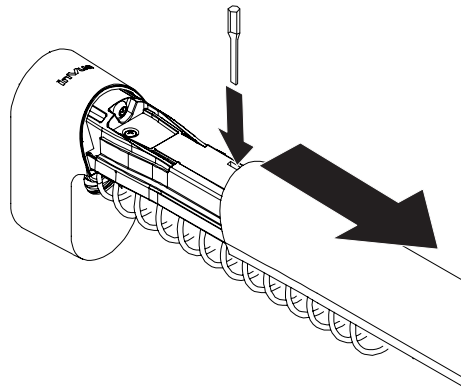

3 While holding the barrel open, feed the hook through the hole in the back of the rear housing. Ensure the hook feeds all the way through the coil.

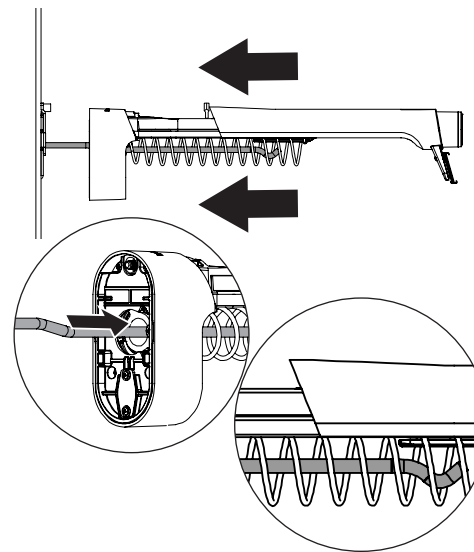

4 Push the T1000 against the wall while aligning the screw with the hole in the screw plate. **Continue to hold the barrel open.**

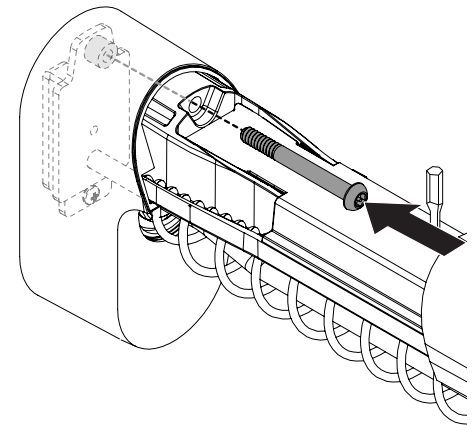

- 5 Tighten the screw using the T20 bit with the multitool (AF6313.) Remove bit and release the barrel so it returns to the closed position.
Note: Do not overtighten screw.

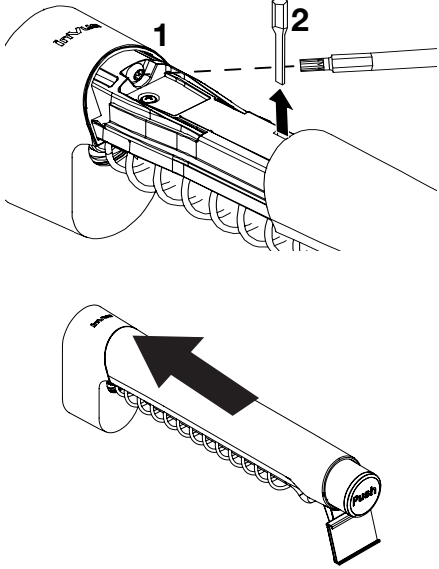

- 6 **Loading product:**
 Place merchandise packaging on hook and hold against coil.
Note: Before loading any products make sure all tension on the internal spring is released by depressing the button until the coil no longer moves.

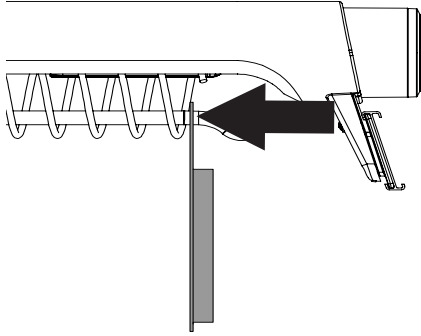

- 7 While holding the packaging against the coil, pull barrel to its **full extension** then return it to its closed position. Verify product is hanging on the rod and the coil is not threaded through the hangtab.

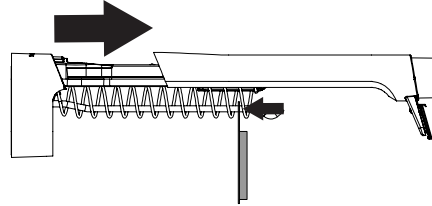

- 8 Repeat to load additional products, ensuring that one product is loaded in each coil space.
Note: Do not overload past the last coil space.

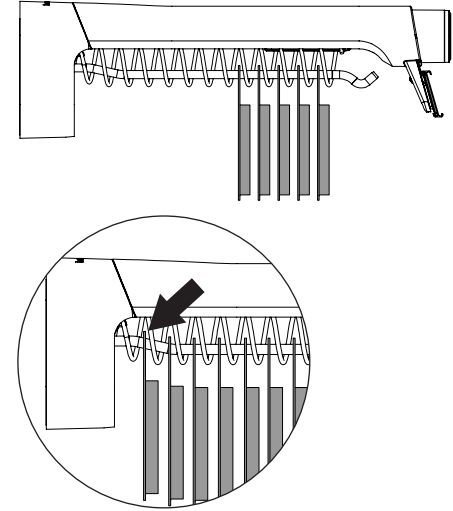

- 9 Push button to dispense merchandise.

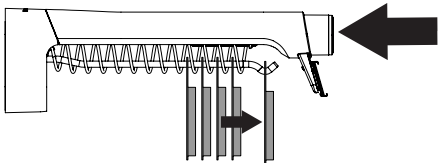

SD0471 Rev3 11/29/2017

invue

www.invue.com

NA / LATAM // 704.752.6513 • 888.55.INVUE

EMEA // +31.23.8900150

APAC // +852.3127.6811