

W2000

Stand - ZW2000-B/W

Trim Kits - ZW2070-B/W

Custom Watch Sensor - ZW2068-B/W

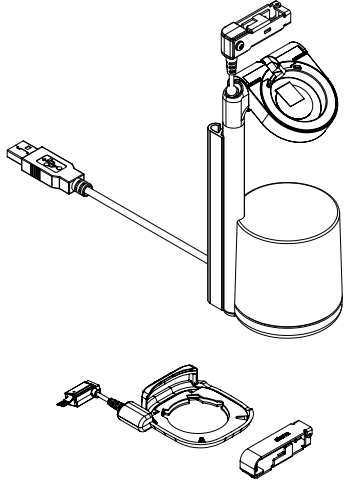

- 1** Use the provided alcohol wipe to clean the fixture where the stand will be placed. Allow it to dry completely.

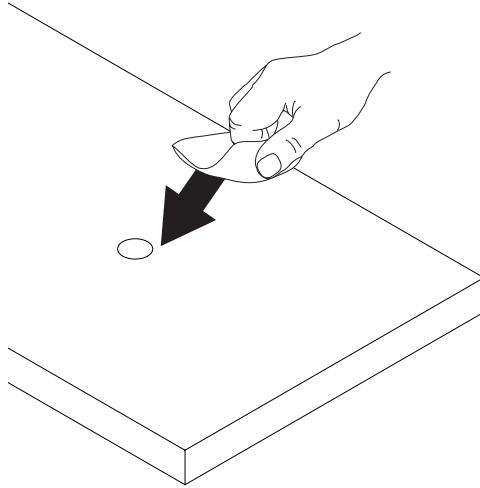

- 2** **OEM Charger Trim Kit Installation:**
If installing an OEM charger and/or trim piece, use a key fob tool to remove the plug from the side of the cradle.

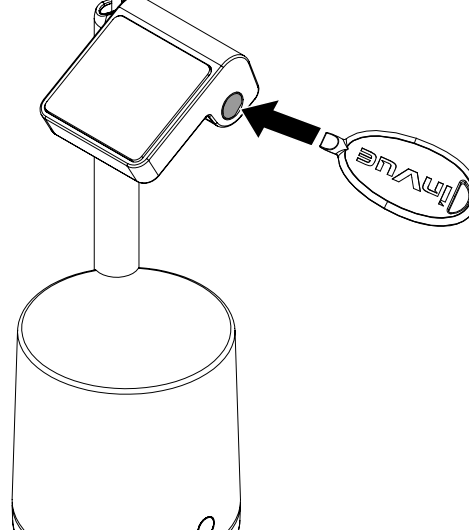

- 3** Remove the plug and use the TT8 bit to remove the screw from the side of the cradle

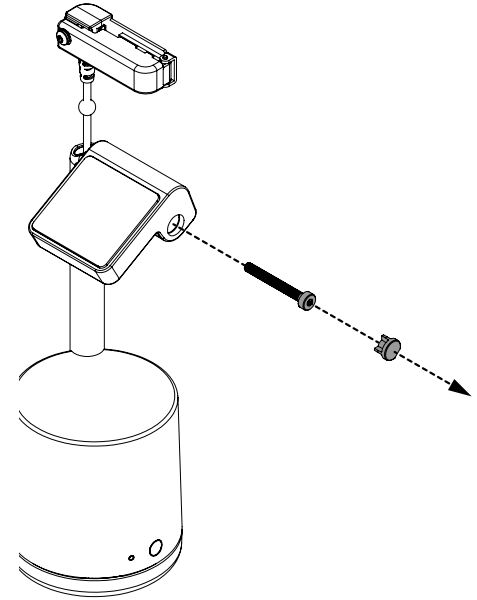

- 4** Remove the original cradle from the stand.

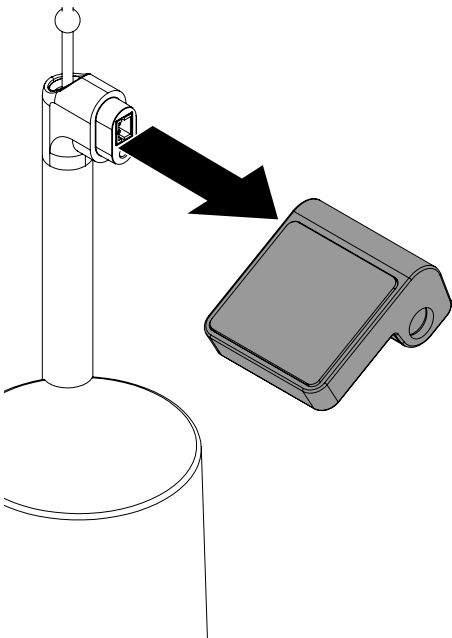

- 5** Place the new cradle included in the kit onto the stand.

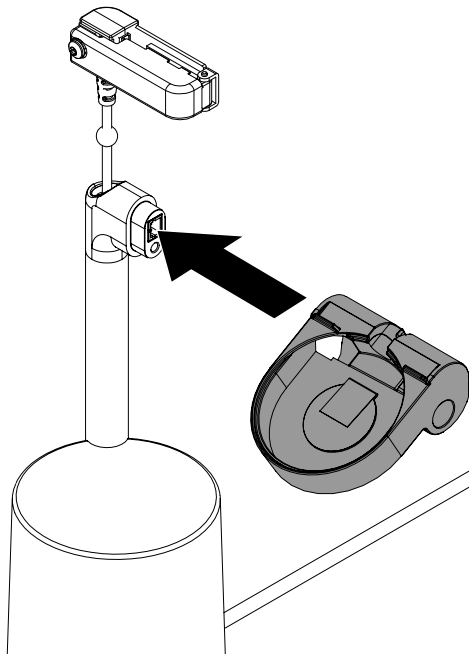

- 6** Secure the new cradle with the screw. Insert the plug into the hole in the side on the cradle.

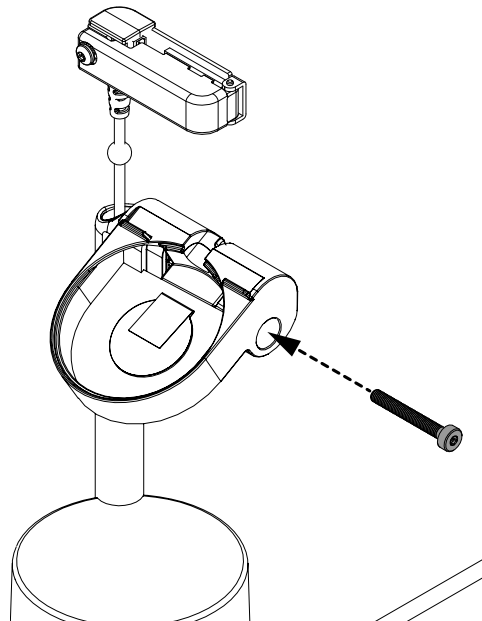

- 7** Select the charger insert that matches the device being installed.
- The hard plastic insert with the mounted adhesive is for GW6 & GW7 devices
 - The black rubber insert is for all previous model generations.

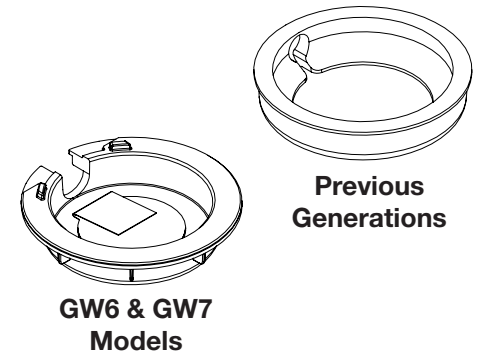

8 Pull the red tab from the adhesive in the charger insert.

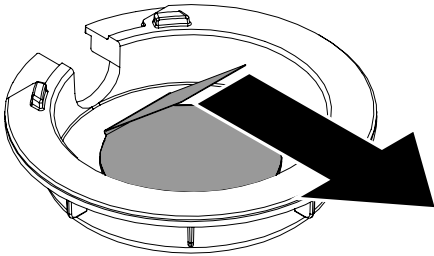

9 Place the OEM charger into the cradle insert, with the strain relief on the charger fits through the gap in the insert. Apply pressure for at least 10 seconds.

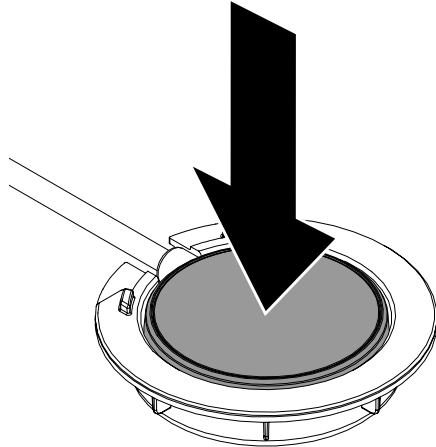

10 Use an alcohol wipe to clean the bottom of the cradle insert. Allow it to dry completely.

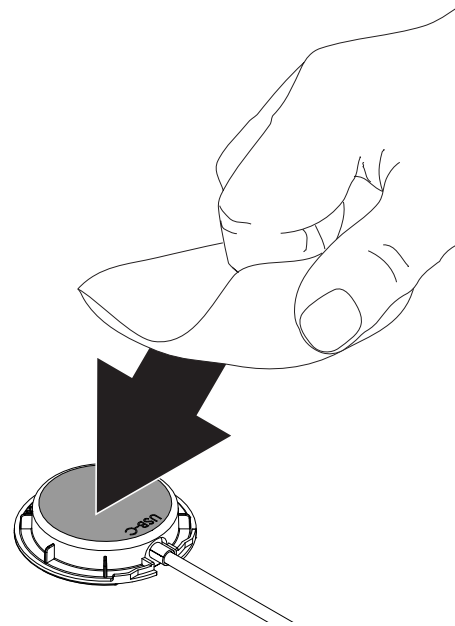

11 Pull the red tab from the adhesive in the charger cradle.

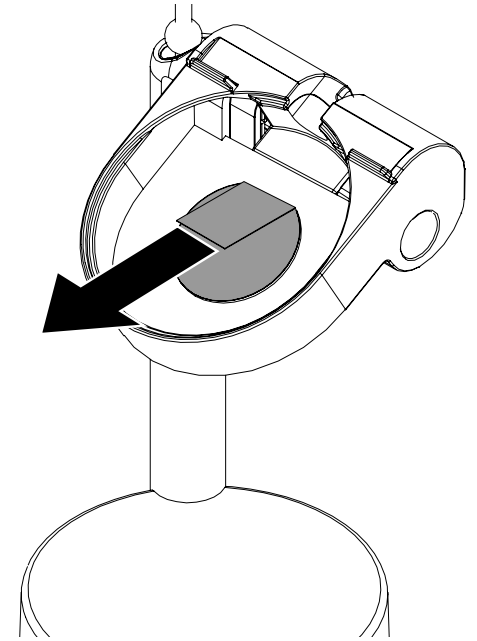

12 With the charger cable facing towards the groove in the charger cradle, place the OEM charger and cradle insert into the cradle. Apply pressure for at least 10 seconds.

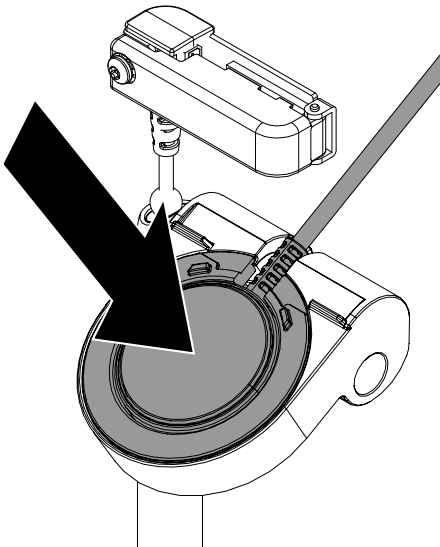

13 Use the provided alcohol wipe to clean the stem. Allow it to dry completely.

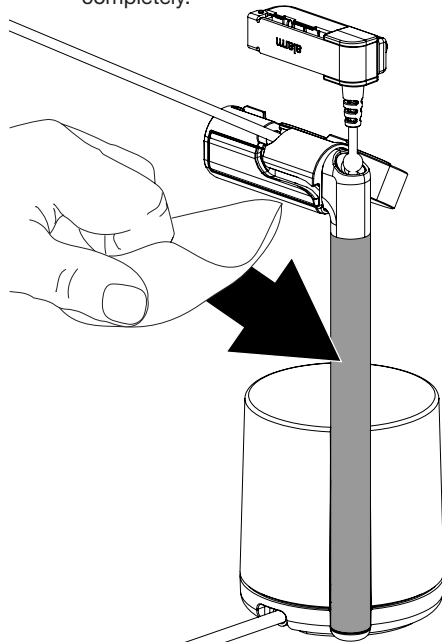

14 Route the OEM charger cable into the cable guide.

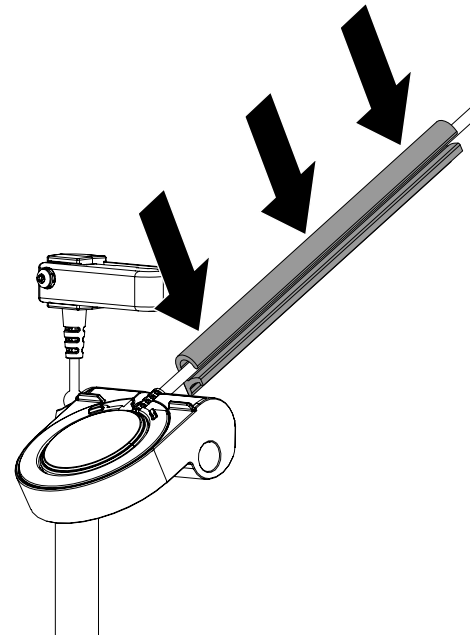

15 Peel the clear film from the 2 adhesives on the cable guide.

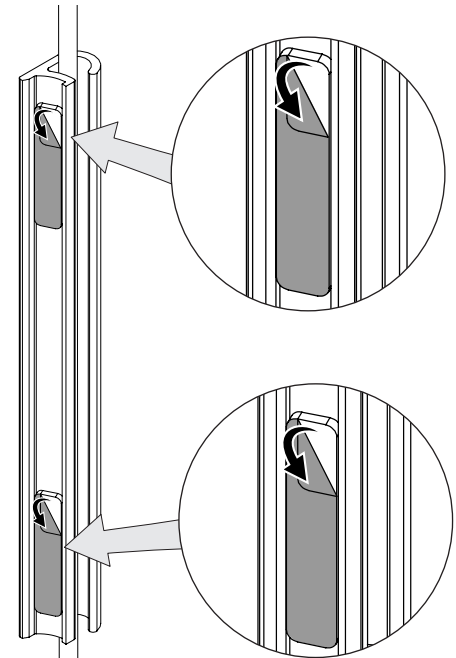

- 16** Align the bottom of the cable guide to the bottom of the stem. Apply pressure for at least 10 seconds.

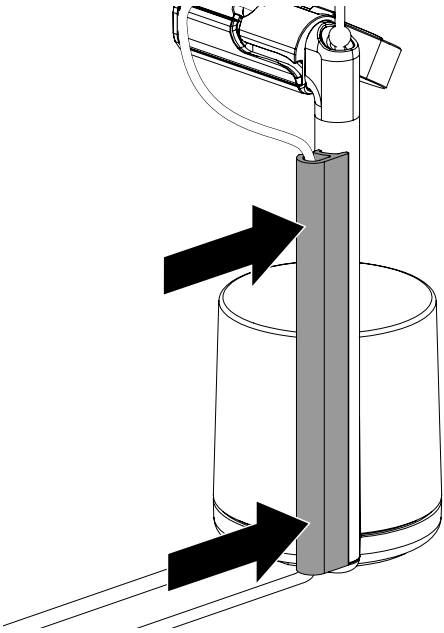

- 17** Route the cable along the track in the back of the cradle. Adjust the cable in the cable guide as necessary.

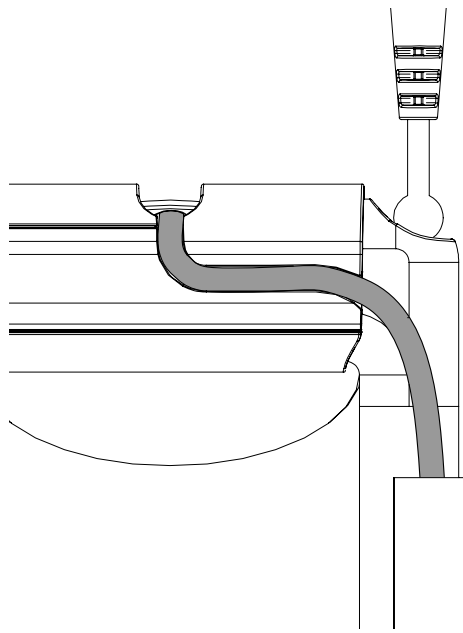

- 18** **Stand Installation:**
Peel the clear film from the adhesive on the bottom of the stand.

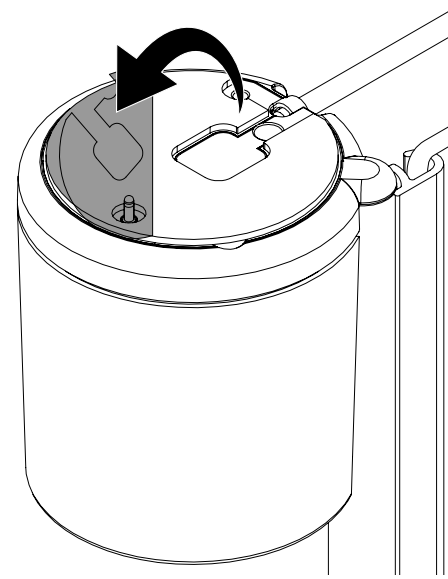

- 19** **Optional:**
Route the power cable and OEM charger cable through a hole or slot in the fixture.

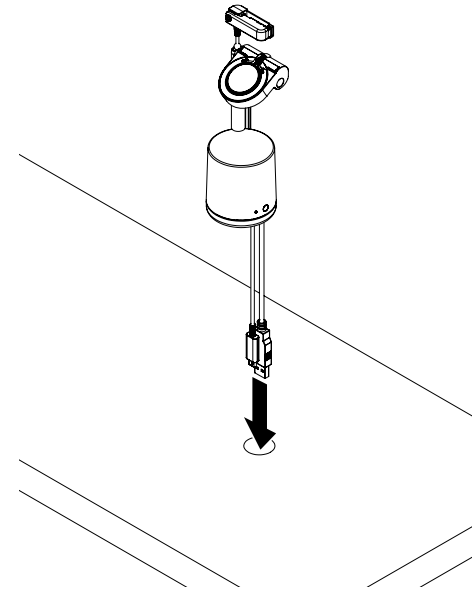

- 20** Place the stand in the desired location and apply pressure for at least 10 seconds.

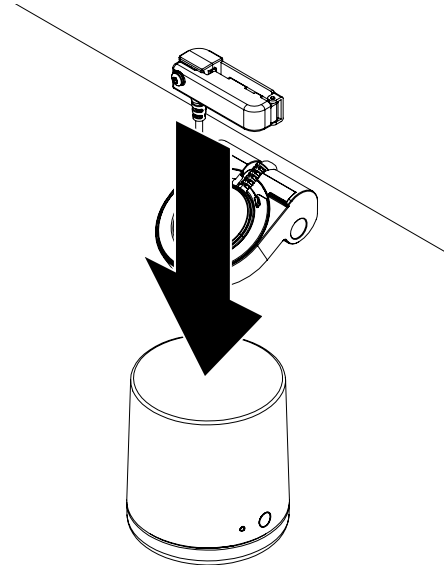

- 21** **Tray Sensor Installation:**
Use an alcohol wipe to clean the bottom of the device, allow it to dry completely.

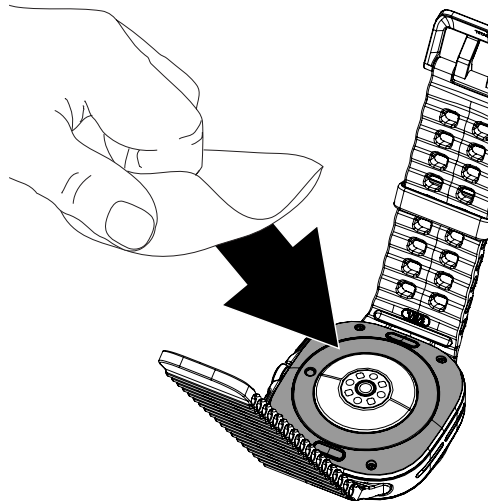

- 22** Press the band release button on the device and remove the buckle band.

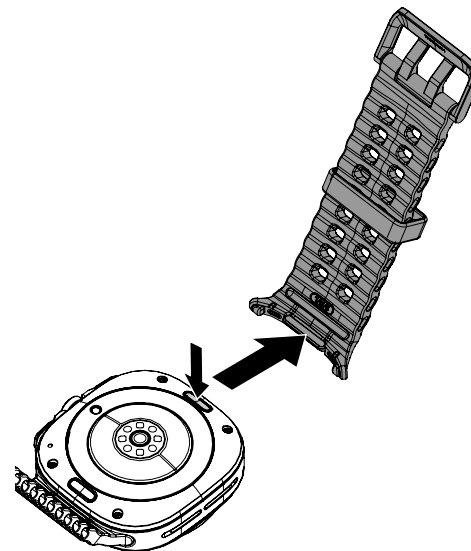

- 23** Peel the clear film from the adhesive in the tray sensor.

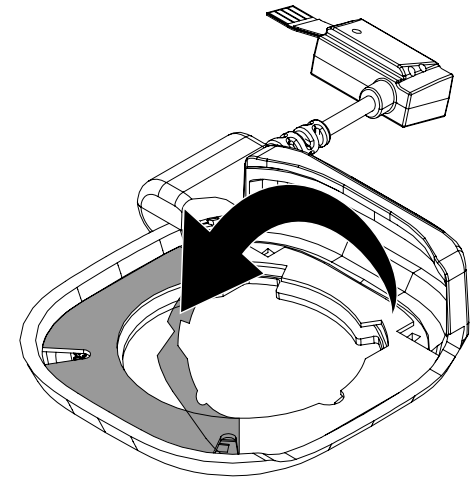

24 Insert the buckle band through the opening in the tray sensor.

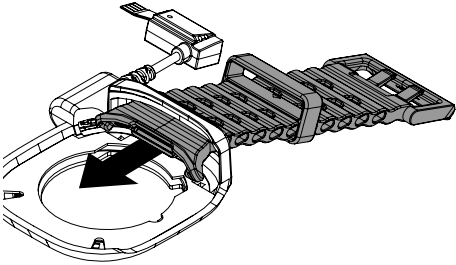

25 Reconnect the buckle band and watch body.

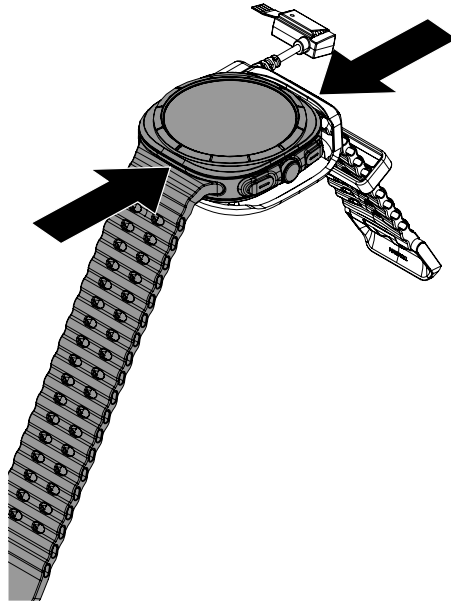

26 Press the watch body and tray sensor together for at least 10 seconds.

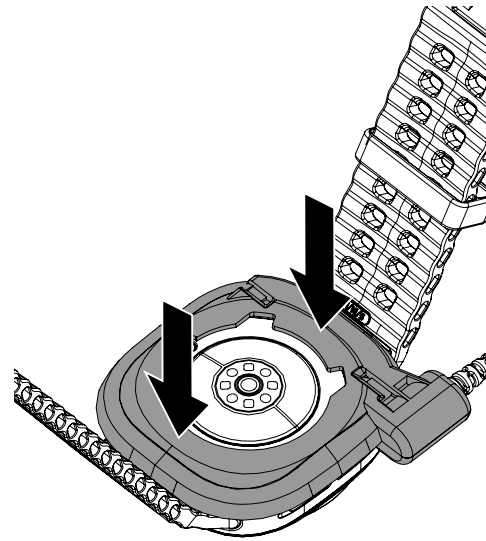

27 Lift the connector from the stand, pulling enough cable to aid in the installation of the sensor. Snap the included cable stop clip around the cable to prevent it from retracting.

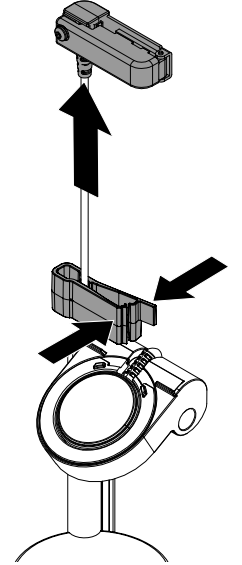

28 Use a TT8 bit to loosen the screw in the band clamp.

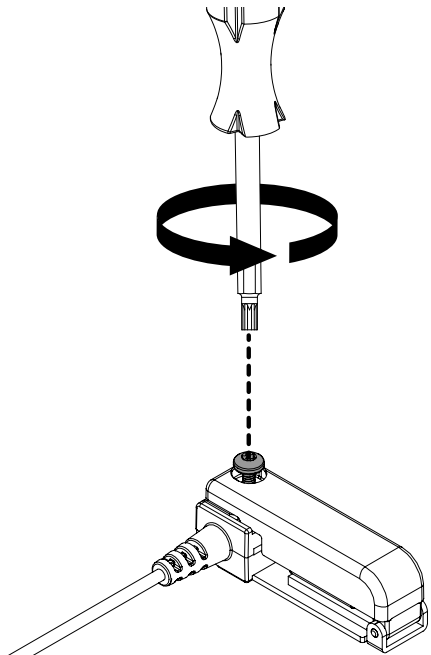

29 Open the band clamp.

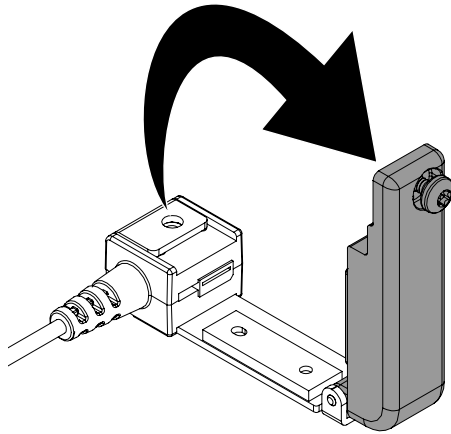

30 Slide the band clamp off of the sensor.

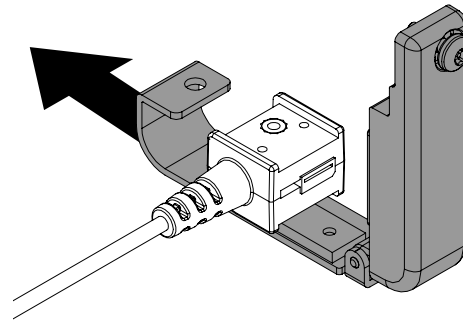

31 Slide the provided band clamp onto the sensor.

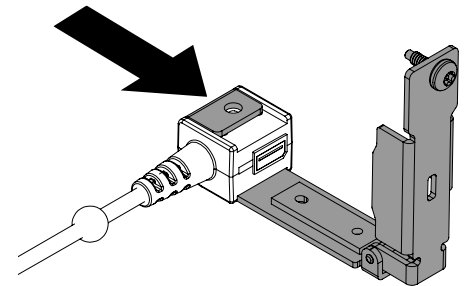

32 With the wearable facing down, place the buckle side band down into the band clamp.

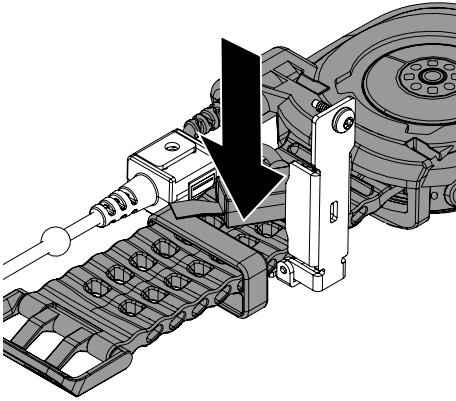

33 Plug the connector into the sensor cable.

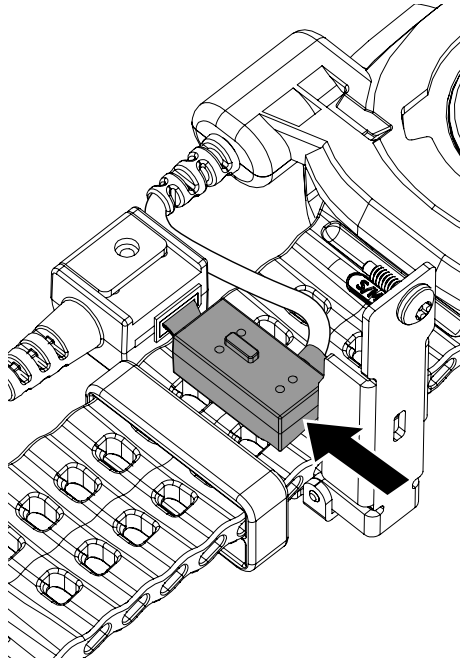

34 Close the band clamp over the connector.

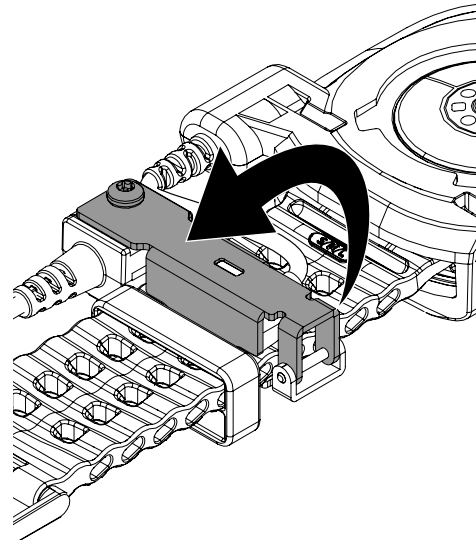

35 Use a TT8 bit to tighten the screw in the band clamp.

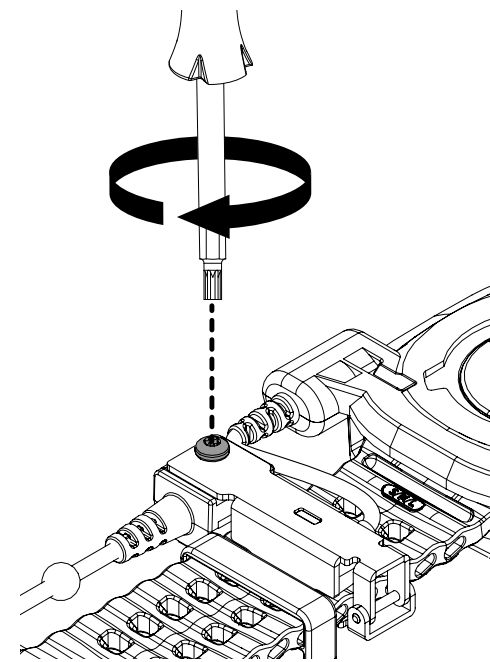

36 Remove the cable stop clip from the cable.

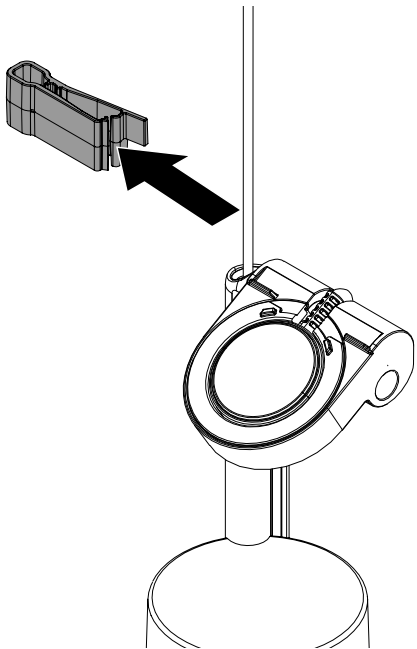

37 Place the wearable onto the charger.

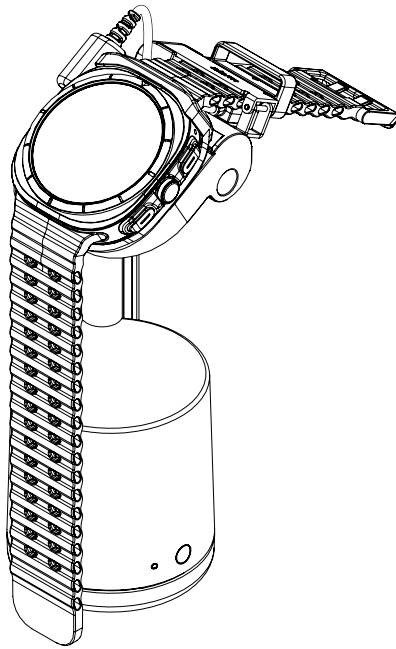

38 Plug the charger cable into the power supply. Plug the power supply into an outlet. Make sure that the watch is receiving power.

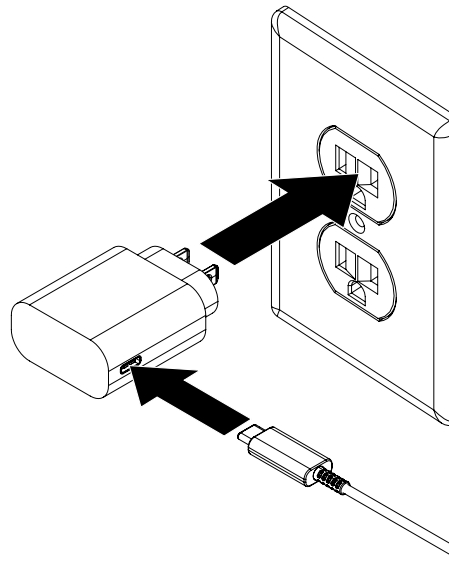

39 Plug the stand's power cable into a PS515 power supply and plug the power supply into a power outlet.

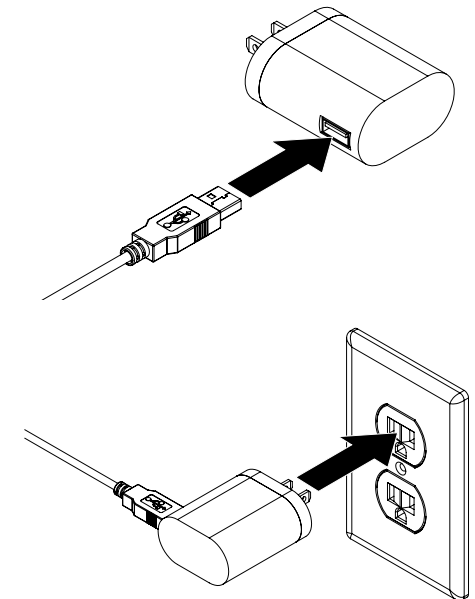

40

Place a charged and coded OneKEY against the lens on the side of the stand. Press the button on the key to transfer the code to the stand. This method is also used to deactivate the alarm.

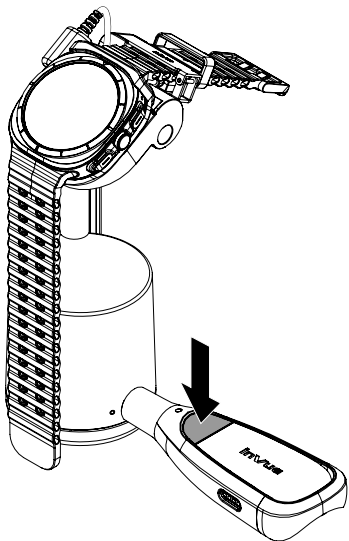

SD0976 Rev1 07/10/24

INVUE

www.invue.com

NA / LATAM // 704.752.6513 • 888.55.INVUE

EMEA // +31.23.8900150

APAC // +852.3127.6811

© 2024 InVue Security Products Inc. All rights reserved.
InVue is a registered trademark of InVue Security Products.