

**FABB** furniture



Lounge  
Booklet

# Contents

On delivery of your lounge	04
Why choose Fabb Furniture?	06
Lifetime Frame Warranty	08
Caring for leather & fabric lounges	10
Adjustable features, connections & batteries	14
Natural features of leather	17
Delivery considerations	19
Warranty information	20
Keeping in touch & delivery information	24





# On delivery of your lounge

Congratulations on your purchase of a beautiful Fabb Furniture lounge, which will give you years of comfort and enjoyment.

Like any product which is hand-made from a natural material such as leather or a finely milled fabric, there are many things you need to be aware of to ensure the life of your lounge is long and enjoyable.

This booklet is designed to give you a detailed understanding of your lounge, including how to care for it from the day it arrives in your home.

Leather is a natural product and you will notice many imperfections which are evidence of genuine leather. Please refer to pages 17-18 for a detailed description.

Your lounge has travelled a long way to get to your home. Our Professional delivery team will deliver & assemble your lounge, including any connections for modular components. At this time you may find some compression on the padding - this is entirely normal. To ensure your lounge is safe in transport they are tightly wrapped and insulated for protection. Please refer to pages 10-16 for a detailed explanation, including other important tips to care for your lounge.

For the convenience of our customers, most Fabb Furniture lounges are designed in modules to assist in delivery and relocation. This can result in a divide between the seats - please note that this is standard practice to avoid damage to the suspension, covering and alignment during the settlement period.

If you need to relocate your modular lounge, please refer to page 16 for examples on how the lounge can be connected, to ensure no damage occurs to the structure and alignment of your lounge.

You have an obligation to care for your lounge in accordance with the care instructions set out on pages 10-16 of this Lounge Booklet. Failure to do so may result in damage to your lounge. In particular, leather as a natural product, is susceptible to cracking and peeling if it is not properly cleaned.

If you fail to take reasonable steps to prevent your product from becoming of unacceptable quality and your product is damaged as a result of such abnormal use (including the failure to properly care for the product as instructed), to the fullest extent permitted by law, Fabb Furniture will not be liable for repairing that damage to your product.

By following all of the tips and instructions on pages 10-16, you will ensure years of enjoyment with your lounge.



# Why choose Fabb furniture?

Welcome to Fabb Furniture, your go-to destination for all your furniture needs. With our rich heritage and expertise in the industry, we have been providing top-notch furniture options for over 40 years. Whether you're looking to furnish your living room, bedroom, dining room, or any other space in your home, we have the perfect pieces to suit your style and budget.

## A Legacy of Quality and Craftsmanship

At Fabb Furniture, we take immense pride in our long-standing history and commitment to delivering exceptional furniture to our customers. Founded in 1979, we have built a reputation for offering high-quality, durable, and stylish furniture that stands the test of time. With 150 years of bed heritage, we understand the importance of a good night's sleep and strive to provide comfortable and supportive mattresses and bed frames.

## A Nationwide Presence: 22 Stores and Counting

With 22 stores located across the country, we are easily accessible to customers from all corners of the UK. Whether you prefer the convenience of online shopping or the personal touch of an in-store experience, we have you covered. Our stores are staffed with knowledgeable and friendly experts who are ready to assist you in finding the perfect furniture pieces to transform your home.





# We've got your back

## Lifetime Frame Warranty

All of our leather and fabric lounges are protected by a Lifetime Frame Warranty, covering structure and framework. Please refer to pages 20-23 for full details.

All lounge frames are constructed from a combination of structural components, engineered to give the frame strength and durability for many years.

Each manufacturer has a slightly different method and you can see various examples of the method our frames may be constructed on the facing page.

### The common characteristics to all of these methods are:

- Kiln dried timber acting as the main structural support
- Resilient high density foam core in all cushions
- Robust polyester fibre fill and Dacron filling for support and shape
- Zig-Zag springs or highly tensioned elastic webbing seating support

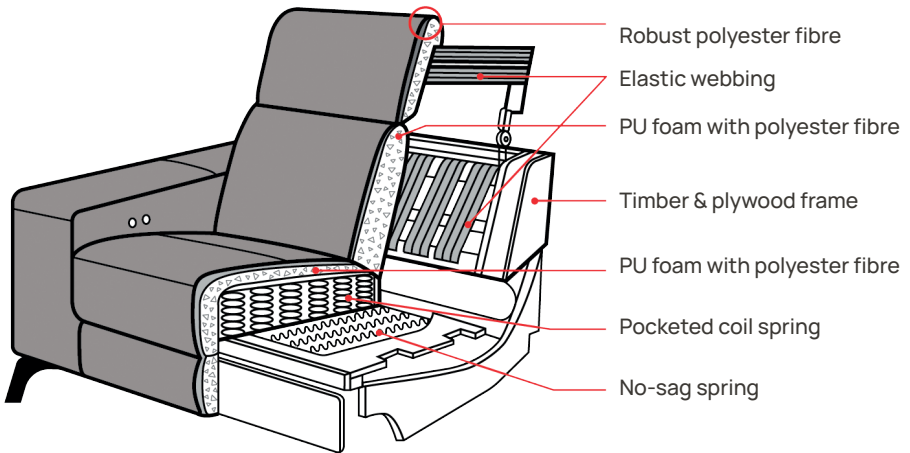



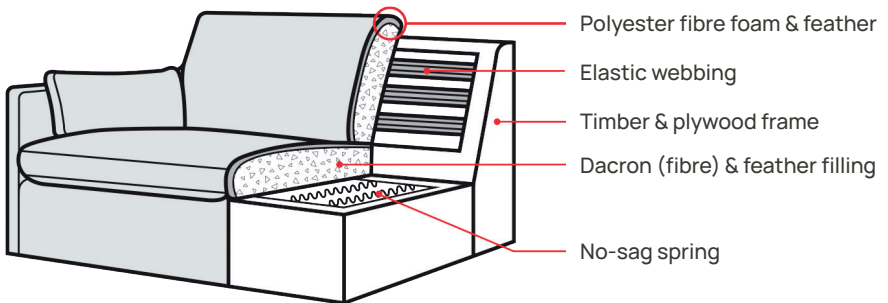
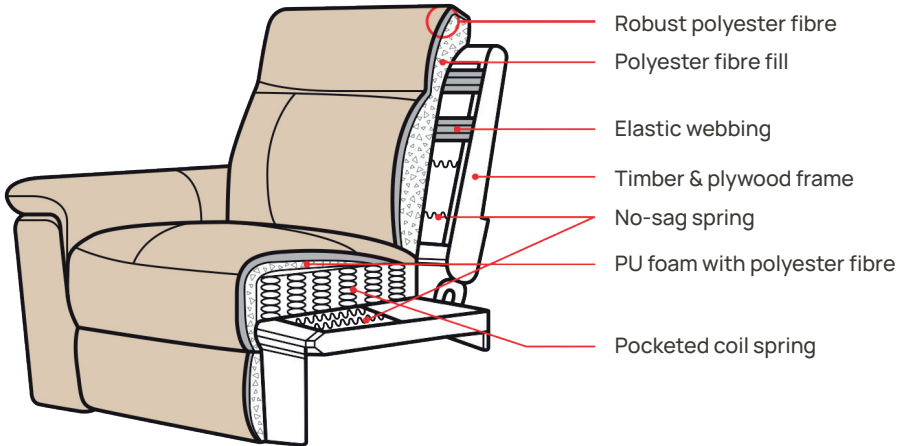
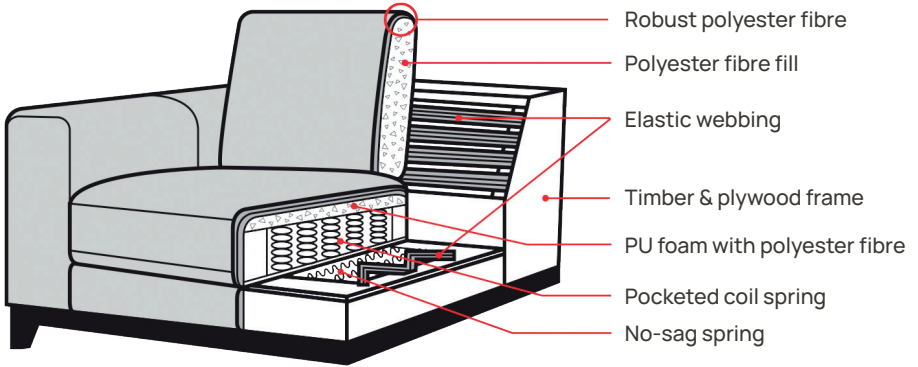

# Caring for leather & fabric lounges

There is no doubt leather is one of the most beautiful and practical coverings for upholstered furniture. Durable and hard wearing, if maintained correctly, it's a product that will provide years of trouble free enjoyment. There are, however, some very important care tips that must be followed to prolong the life of your leather.

## Important things to avoid

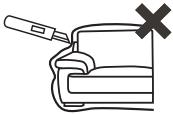

- 1 If you are removing any protective wrapping do not use any sharp tools which could damage the leather or other upholstered covering.



- 2 If you move your lounge do not lift or drag it by the cushions which are sewn into the frame. The correct way to move it is by lifting the lounge, at each end, from the base.

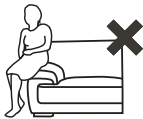

- 3 Please do not sit on the armrests and backrests. They are not designed for seating and could potentially damage the frame.

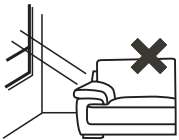

- 4 To prevent fading, lightening, or discoloration of the leather or fabric, do not allow any part of the lounge to be directly exposed to sunlight. Prolonged exposure to intense sunlight can cause excessive drying and cracking of the leather.

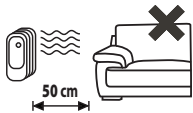

- 5 Ensure that every edge or part of the lounge is placed at least 50cm away from any heat source, including electric or gas heaters.



- 6 Never use solvents, abrasives, shoe or saddlery care products. To ensure your warranty is not voided, only ever use Fabb Furniture fabric & leather care products as they have been tested and designed across our entire range of fabrics and leathers. These are available at your local Fabb Furniture store or online.

Dye transfer is an effect of some types of dyes. Denim and coloured synthetic fabrics, combined with the heat and friction of use, may transfer dye to the covering of your lounge. This is not a manufacturing fault and it is best to avoid these types of clothes when using your lounge. Avoid chlorine or wet swimming costumes. Chlorine is a bleach which will damage the fibres of the leather and can contribute to water marks, mould and dye transfer.

## Normal wear & regular usage

- 1 Following delivery you may notice slight compression on the padding of your lounge. Straight after delivery, and on a regular basis thereafter, it is necessary to model your lounge to ensure the padding and cushions return to its initial appearance.
- 2 Softening of padding and cushions will occur over time. This will cause light creasing, wrinkling and slight stretching of the leather which is considered to be normal wear, enhancing the look and feel of leather.
- 3 Softening of seat cushions over time is completely normal and is not considered a defect in any way. Sitting on one particular seat most of the time will cause that seat to soften more than the others. For an even wear, alternate your choice of seat regularly.

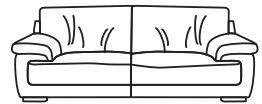
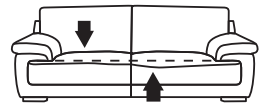
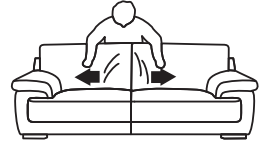

## Fabric & leather puddling

As our lounges are optimised for comfort, our covering must allow for softening over time. These coverings are adapting to a plush and tender filling, and must transform with your lounge over time.

Please note that this is considered normal wear and tear. If we prioritised a taut material over a rigid surface, the material would stay pristine, but unsuitable for comfort.

# Regular care & cleaning of leather lounges

## Cleaning Performance leather

Do not allow dust to accumulate on the leather surface. Weekly, wipe dust off with a soft, damp cloth or using an authorised product purchased from Fabb Furniture.

Weekly, wipe dust off with a soft, damp cloth and regularly clean your leather with a Fabb Furniture care product to ensure your product is covered under our warranty. Failure to do so will result in dust and dirt being embedded in the grain which could cause the leather to peel or crack.

Periodically (3-4 times per year), clean, condition and protect the entire leather surface using a Fabb Furniture leather furniture care kit designed and tested exclusively for our signature range of leathers. The furniture care kit can be purchased from any Fabb Furniture store and online ([www.fabbfurniture.com](http://www.fabbfurniture.com)).

## Food, grease & spot cleaning

Any spills must be removed immediately using a soft, non abrasive damp cloth or absorbent paper, applying minimal pressure from the outside of the stain moving towards the centre.

To clean further, use only a Fabb Furniture leather furniture care kit, which can be purchased from any Fabb Furniture store or online. Follow the specific spot cleaning instructions provided with the kit.

## Cleaning Vintage leather

Regular maintenance is important to keep your Vintage look leather looking its best. Dust gently with a soft cloth to keep it free of surface dirt. Noticeable soiling can be wiped with a clean, damp cloth. Take care not to soak or vigorously rub the leather and always wipe with a dry cloth after cleaning.

Never use detergent on the leather. To clean further, only use a Fabb Furniture leather furniture care kit which can be purchased from any Fabb Furniture store to ensure your warranty is not void.

Consult a specialist leather upholstery cleaner if badly soiled. Watch out for sharp objects, belt buckles and pets' claws. Keep lounge out of direct sunlight to avoid fading. Keep away from direct heat.

## Dye batch variation of leather

Due to the bespoke nature of our lounges, it is important to be aware that dye-batches for both leather & fabric can differ from the model on display and the samples seen in the showroom.

## General care & characteristics of fabric lounges

Try to keep pets off the furniture and be careful of belts, toys and watches as they may snag the fabric. Do not pull loose threads; tie a knot and/or cut them instead. It is important to plump the cushions after everyday use, particularly those filled with fibre fill or feathers, and to smooth out the surface to prevent permanent creases forming. Any reversible seat and back cushions should be turned regularly.

## Care & cleaning of fabric lounges

Refer to the instructions before cleaning. Only use a Fabb Furniture fabric furniture care kit, which can be purchased from any Fabb Furniture store or online ([www.fabbfurniture.com](http://www.fabbfurniture.com)).

This is important as it has been designed and tested with our fabrics in mind and will ensure your warranty is not void. For spot cleaning and stain removal, please follow the instructions provided with the kit.

Use a low suction vacuum or light brush to

clean your furniture weekly to remove any accumulated dirt and dust. Clean all parts of the suite together as slight colour changes can sometimes occur. Do NOT use solvents, general cleaning fluids or any products containing silicone.

## Fabric pilling

Pilling can occur as a result of normal daily use and is not considered as a fault. There are many variables that can attribute to pilling such as, climatic conditions, atmospheric purity and the user environment. Even specific types of clothing can transfer pills from clothing to the fabric.

As the fabric surface is rubbed a single or small group of fibres on the surface begin to twist forming what is known as 'pills'. Often the catalyst for this is a foreign fibre or speck of dirt. Pilling can successfully be removed by the use of a battery operated de-pilling tool available from most haberdashery stores. Velvet and chenille type fabrics have a raised surface texture, which is exposed to flattening and shading, this is an important characteristic of the fabric to know and is not considered a fault in any way.



# Adjustable features, connections & batteries

## Reclining armchairs & lounges

Armchairs and lounges with a reclining mechanism offer you the ability to change the inclination of the back, positioning the legs horizontally, and changing the seating position so that you can recline. If you have purchased an armchair or a lounge with the wall saver sliding function, you will be able to recline it without having to move your upholstered furniture away from the wall. The electric recliner mechanism allows you to finely adjust the back inclination and the foot rest position as preferred.

### **Please Note:**

- The footrest must be retracted prior to standing up from the seated position
- Do not sit on the arms, backs or footrest when the recliner is in the open position
- Always keep hands and feet clear of moving parts
- Only use the electronic mechanism to operate the unit
- Always disconnect the electrical cord attached to the unit from power before cleaning or moving the unit
- Please remove any obstacle obstructing the mechanism, for example plush rugs or coffee tables, before operating

## Lounge alignment & quality control

Rearrangement of modular pieces from what was originally ordered can result in an uneven alignment. To ensure the best fit for your lounge, the arrangement of modular pieces is crucial.

Our lounges are carefully crafted by hand, following the configurations ordered. We arrange the pieces from left to right and assign them sequential numbers to maintain the original order you selected (pictured top-right).

During delivery, our drivers will assemble the lounge in the exact sequence you requested. If you decide to rearrange the order of the modular pieces, it may be possible, but please note that this may result in some irregular gaps and slight misalignment.

We do not allow customers to add an additional piece into an existing lounge as the new piece will differ in wear and tear. In addition, as your lounge is a hand-made product, heights and lengths may differ slightly between batches causing irregular gaps and misalignments, especially those lounges with adjustable headrests and reclining capability.

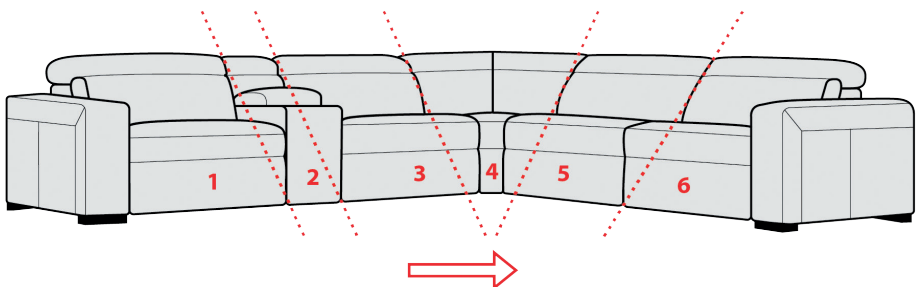

## Battery longevity & maintenance

Please ensure you follow the battery care instructions delivered with your lounge. Never allow the battery to be fully depleted, and ensure it is consistently charged every 21-28 days, even if used sparingly. Each battery has a lifespan of up to 12 months.

Fabb Furniture does not sell batteries separately. To purchase another battery-pack after 12 months, you need to buy from an external battery supplier.

It is important to note that the battery's longevity largely depends on whether it is charged in accordance with the instructions provided, to ensure optimal performance.

Please be aware that leaving a re-chargeable battery on charge for too long poses a fire safety risk. Never over-charge for longer than directed.

Being a lithium battery, we strongly suggest for safety reasons, that you replace and do not use the battery packs for longer than 12 months. Refer to our Conditions of Sale & Warranty information for more detail.

We cannot retro-fit battery power to an existing electric-powered lounge or after a lounge has been ordered. It must be decided at the time of ordering the lounge.



Scan to access battery care instructions

---

## How to use the click-clack mechanism

A new innovation in lounge design is the click-clack mechanism which enables the adjustment and locking of arms, backs and (or) headrests in some lounges. Care should be taken when using this mechanism. In most cases, to adjust upwards simply lift up.

To return to its original position pull upwards gently and lift to release the lock, then gently push down to original position. Do not sit, stand or use excessive force on an adjustable arm or back in its adjusted or original position.

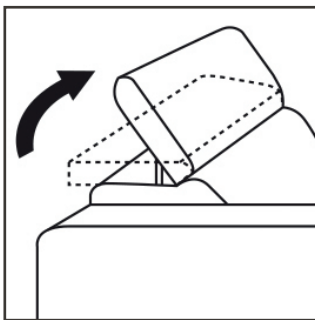

(1) To Lift Up

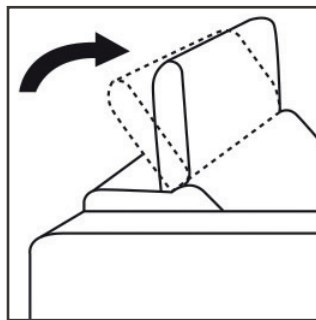

(2) Pull & Release

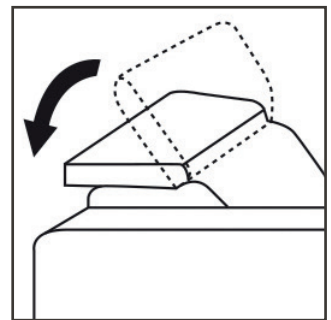

(3) Back To Original

## Modular connections

If you need to relocate your modular lounge, please ensure you disconnect the interlocking connections prior to moving. Dragging or lifting a connected lounge can cause permanent damage to both the frame, and the alignment. Follow the applicable diagram steps below to disconnect, and the reverse to reconnect. For your safety please ensure all lounges are reconnected prior to use.

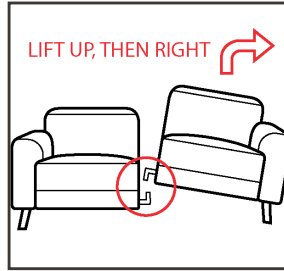
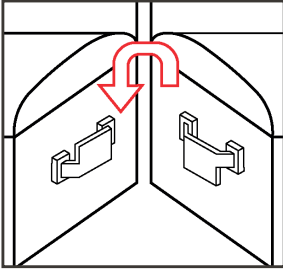

If your lounge connects via two clips, ensure that both are connected prior to use. Both clips must be fully bedded in the clip. Risk of tipping or damage can occur if clips are not properly connected.

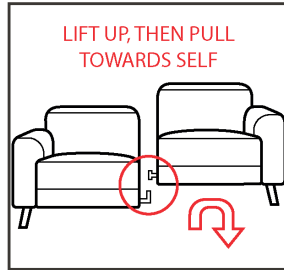
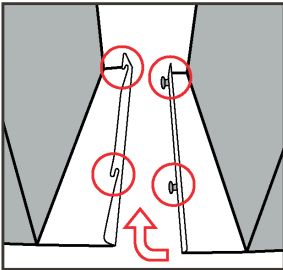

If your lounge connects via a track, ensure that both the front & rear connectors are properly bedded in the track before use. If only one connection is established, it can cause alignment issues and risk of tipping.

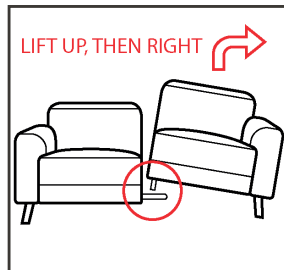
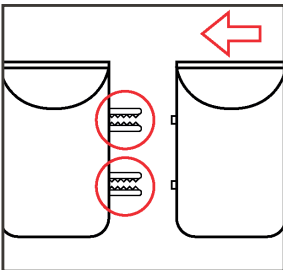

If your lounge connects via teeth and peg, ensure it makes a clicking noise as each tooth locks against the peg. Ensure both connections are secure to avoid any risk of tipping.



# Natural features of leather

As a natural product, leather's beautiful look and luxurious feel give it year round comfort and appeal. Its unique ability to breathe also makes it ideal in almost any situation.

The hallmark of genuine leather is its natural markings and imperfections - nature's signature. Because of its organic properties, there is no one hide the same. From horn wounds and barbwire scratches, to thickness variations affecting colour, these markings make your piece unique.

Grain wrinkles, stretch marks and closed scars are also typical characteristics of leather, the result of age, movement and comfortable wear. This further stamps its authenticity as a natural product.

Leather is a natural product. All of these imperfections are evidence of the product being genuine leather and are not considered to be defects in any way. Without a doubt leather is the most luxurious and practical covering for upholstered furniture. Enjoy living with leather as, over time, it will adapt itself to your lifestyle and give you a truly personalised feel.

## Vintage look & feel

The natural, vintage-look leather is a top-grain leather that is carefully finished to accentuate its natural surface markings, textures and colour variations. We go to great lengths to use only the highest quality leather, but variations are just part of the individual appearance.

Each hide is as individual and unique as a fingerprint, showing scuffs and scratches that bring character to each piece and serve proof of its authenticity, distinguishing genuine leather from man-made look-alikes.

During the specialist finishing process, a protective surface of wax is hand rubbed onto each hide to achieve a slightly distressed appearance.

When the product is first unpacked, you may notice a waxy film on the surface of the leather (like a grey dust). This is part of the unique finishing process, which will sink into the hide with use to create a rich, smooth lustre, deepening into a beautiful aged look. Rub gently with a dry cloth to bring out the shine.



Scars & insect bites



Wrinkles & wounds



Colour variation

## Types of leather

There are many types of leather which are suitable for different uses. How do we know what is the best leather for our needs? Simple! Your lifestyle will determine which is right for you. To make it even easier, we have grouped our leather into three lifestyle categories: Protection, Performance and Natural.

### Protection – robust & resilient

Active families require leather that offers a high degree of protection and is particularly forgiving. It is highly resistant to liquids, sunlight and handles the wear and tear that an active lifestyle demands. Protection leather requires little maintenance and has been embossed to ensure consistency in colour and texture. Ideal for families.

### Performance – extra softness & protection

For those not so active, yet everyday users, who enjoy the luxury of feeling soft leather. It is the best of both worlds. It combines softness with durability. This leather shows all of the distinctive markings of the animals life. It combines glove like softness with good resistance to wear and tear.

### Natural and/or Vintage – lightly protected or unprotected leather

This leather possesses natural beauty and is the most valuable of all. Natural markings enhance the overall appearance. Natural leather can be treated with only the lightest impregnation of pure Aniline dye, which will show many shade variations and add richness to the colour. For a more uniform look, Natural leather can also be treated with a Semi-Aniline dye, yet still showing some natural markings and characteristics of the hide.

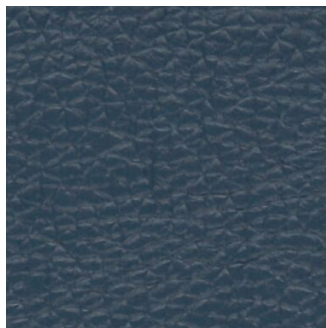

Protection

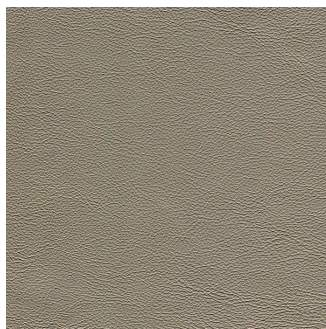

Performance



Natural

# Delivery considerations

## Ensuring safe delivery & installation

Our sales team are here to assist you with finding the perfect lounge for your home. While this lounge solution may be ideal in your space, it is important however to ensure our delivery technicians can safely deliver & install your lounge without any risk to your furniture or themselves.

Please ensure you have considered your doorways, passageways, driveway & any stairways when making your purchase, as our sales staff cannot be held responsible for the specifics of your home. Please contact our despatch team to notify us of any narrow doorways, stairs or other potential delivery access issues by calling **01733 336255**.



Please read our Fit Guide

## Delivery & service coverage area

We make every effort to deliver & service to as many parts of the UK as possible. However

there are areas outside our Delivery & Service Network.

For the safety of our customers & warehouse staff, we insist on professional couriers for any Pick-Up from our Distribution Centres. At this point, your chosen courier will become liable for furniture during transit.

Please also be aware that if you move a product outside the scope of our Delivery & Service Network and there are any warranty issues, you will be responsible for arranging and financing the return of your lounge to the nearest distribution centre for assessment.

## Independent storage of goods

If you intend to store your lounge prior to installation, please ensure you check all goods upon taking possession, as any manufacturing faults must be addressed at this time.

Unfortunately, As Fabb Furniture cannot verify if a fault has occurred from manufacturing or from negligence, we cannot validate claims made after prolonged storage of goods.



# Warranty information

Fabb Furniture provides the original purchaser of this product a guarantee against defects in workmanship and materials as well as your statutory rights as a consumer. The guarantee period will vary on product components, as detailed below. It is important to note the warranty commences on the date of your original Tax Invoice which is usually issued the day before your delivery date.

## Summary of your key legal rights

The Consumer Rights Act 2015 says goods must be as described, fit for purpose and of satisfactory quality. During the expected lifespan of your product your legal rights entitle you to the following:

- Up to 30 days: if your goods are faulty, then you can get a refund.
- Up to six months: if your goods can't be repaired or replaced, then you're entitled to a full refund, in most cases.
- Up to six years: if your goods do not last a reasonable length of time you may be entitled to some money back.

If, during the warranty period, a defect caused by faulty workmanship or materials appears, Fabb Furniture or a designated third-party appointed by Fabb Furniture, may need to perform an in-home inspection to determine if a manufacturing fault exists.

## Warranty Against Defects

Our warranties against defects and remedies under these warranties are in addition to your statutory rights as a consumer.

## Warranty Periods

Unless otherwise specified in writing by Fabb Furniture (e.g. in a Sales Order), Anglia Home Furnishings Limited warrants that:

- a. the frame used in each Fabb Furniture

lounge is guaranteed against failure due to a manufacturing defect for its lifetime;

- b. The electronic and motion components for all recliners and sofa beds (excluding batteries and transformers) are guaranteed against failure due to a manufacturing defect for a period of 2 years from date of delivery;
- c. All components of your product other than a and b above (including leather, fabric, lacquered and other timber finishes, chrome and metal, glass and marble, travertine and macstone) are guaranteed against failure due to a manufacturing defect for a period of 2 years from date of delivery.

Unless otherwise specified in writing by Fabb Furniture (e.g. in a Sales Order) and subject to the other terms of this express warranty, Fabb Furniture warrants that any Lithium Ion Battery Pack and transformer supplied by Fabb Furniture to you (Battery Pack) will be free from manufacturing defects (Express Battery Warranty) for a period of 12 months from the date of delivery (Express Battery Warranty Period).

If a product is replaced during the Warranty Period, the guarantee period will not reset, and will continue to expire as per the date of delivery of the original item.

To be entitled to claim under the Fabb Furniture warranty against defects, the defect in the part or product must appear within the relevant time period set out above.

## Exclusions

We're responsible for losses you suffer caused by us breaking this contract unless the loss is:

- **Unexpected.** It was not obvious that it would happen and nothing you said to us before we accepted your order meant we should have expected it (so, in the law, the loss was unforeseeable).
- **Caused by a delaying event outside our control.** As long as we have taken

the steps set out in the section We're not responsible for delays outside our control.

- **Avoidable.** Something you could have avoided by taking reasonable action. The ways in which you are responsible for caring for your products are set out in detail in our Lounge Booklet.
- **A business loss.** It relates to your use of a product for the purposes of your trade, business, craft or profession.

Please note that the following may occur as a result of natural and normal usage:

- a. leathers and fabrics will fade and crease;
- b. foam and fillings will soften and form the shape of the user over time;
- c. depending on the covering and the degree of use, the covering materials, cushion fillings and suspension may need to be replaced periodically at the purchaser's expense;
- d. scars, marks and differing pore density and colour are natural characteristics of leather;
- e. the leather and fabric products are upholstered by hand and therefore, the size and weight of these products may have minor variations of up to 5% from the sample products or from any product specifications you have been quoted;
- f. damage caused by spills such as acid, solvents, dyes or other corrosive materials, ink, paint, or bodily fluids;
- g. damage caused by improper cleaning, negligence, treatment of the product with chemicals, exposing the product to the sun, extreme heat or bright light such as lamps, or otherwise caused by your acts and/or omissions.
- h. the failure of the purchaser to take reasonable steps to prevent the product from becoming of unacceptable quality and damage that occurs as a result of such abnormal use. This includes damage that occurs as a result of the failure of the purchaser to care for the product in the manner described in your lounge booklet.

Please also refer to 'Caring for Your Furniture' below.

This goodwill warranty does not affect your

legal rights if there is something wrong with your products (for more on those rights see the summary of your key legal rights above). You can transfer our goodwill warranty to a new owner of the products. We can require the new owner to prove you transferred the product to them.

## Exclusions from Express Battery Warranty

To the maximum extent permitted by law, Anglia Home Furnishings Limited is not liable under this Express Battery Warranty for or in respect of:

- a. any defect that is unrelated to the condition of the Battery Pack at the time it was supplied to you, including damage or faults caused by: improper transportation, storage or installation of the Battery Pack after the date of purchase; modification, alteration, disassembly or attempted repair of the Battery Pack by a person other than, or authorised by, Fabb Furniture; external influences during the life of the Battery Pack, such as fire, water damage or power surges in a premises;
- b. the failure of the Battery Pack to operate on a single charge for any length of time before it requires recharging. Because of many variables, such as the nature and use of the recliner in which the Battery Pack is installed, Fabb Furniture is unable to guarantee that the Battery Pack will operate for any particular period before it requires recharging;
- c. minor issues in the Battery Pack which do not substantially interfere with the ordinary use of the Battery Pack for powering recliner movements. For example, if the Battery Pack is fitted with a LED indicator (which emits particular lights when it is operating or charging), the failure of the indicator to emit any lights does not amount to a manufacturing defect for the purposes of this Express Battery Warranty;
- d. any damage or faults caused by the failure to use the Battery Pack in accordance with the care instructions here, or the failure to take reasonable steps to prevent the problem, or abnormal use of

the Battery Pack (including use beyond the 12 month lifetime period of the Battery Pack); and

- e. any loss or damage suffered by you or any other person in connection with the goods which are not expressly covered by this Express Battery Warranty.

This Express Battery Warranty does not affect your legal rights if there is something wrong with your Battery (for more on those rights see the summary of your key legal rights above).

You can transfer this Express Battery Warranty to a new owner of the products. We can require the new owner to prove you transferred the product to them.

This Express Battery Warranty only applies to the Battery Pack if it is used for normal domestic purposes and excludes Battery Packs used for commercial purposes.

## How to claim a warranty against defects

To claim under these warranties against defect, the Purchaser must:

- notify Fabb Furniture within 7 days after the defect appears;
- only use the product again once Fabb Furniture has confirmed in writing that it remains safe to do so; and
- provide Fabb Furniture a copy of the original Sales Order or tax invoice.

To make a claim, you can lodge a service ticket on this website or telephone our service department of Anglia Home Furnishings Ltd (Gkl House Club Way, Cygnet Park, Peterborough, England, PE7 8JA) on 0330 124 3588 and follow the prompts.

Once a claim has been lodged with our service department, Fabb Furniture will assess your claim, and respond within 10 business days.

Where the claim is not covered by the customer's statutory rights or this warranty, the purchaser is responsible for the expense of making the claim, and the reasonable costs of Fabb Furniture incurred in relation to the claim (including freight costs, house calls and labour). These will be charged to the purchaser at standard Fabb Furniture rates.

## Responsibility for returning Fabb Furniture Goods

Where you are claiming under this warranty, you are responsible for returning the goods to Fabb Furniture at your expense and should contact Fabb Furniture for the return address or to arrange collection by Fabb Furniture.

Where the item is faulty and you are claiming under your statutory rights, Fabb Furniture will arrange for the products to be collected from you, within a reasonable time and at the expense of Fabb Furniture.

## Remedies for warranty against defects

If a part or product has a manufacturing defect, Fabb Furniture will, at the election of Fabb Furniture, choose whether to repair or replace that part or product.

Under the Fabb Furniture warranty against defects, the purchaser has the right to repair or replacement of the defective part or product only.

## General

- In the event of any conflict between these terms and those which may be included in, or implied by, any document forming part of a purchaser enquiry, specification, order or contract, these terms shall prevail.
- We will only use any personal information provided by you in accordance with our privacy policy at [www.fabbfurniture.com/pages/privacy-policy](http://www.fabbfurniture.com/pages/privacy-policy)
- This document shall be construed in accordance with and governed by the laws of England and Wales.

## Caring for Your Furniture

### GENERAL CARE

Please ensure that your furniture is used as it was intended. Do not sit on arms of lounges, do not sit or stand on table tops, and do not pivot on the back legs of chairs.

### SUNLIGHT

As with any product, prolonged exposure of furniture to direct sunlight will harm it. Direct exposure to sunlight will cause leather and

fabrics to fade and may also cause excessive drying. Direct exposure to sunlight will cause timber products, particularly doors, tops and side panels to warp.

#### **LEATHER UPHOLSTERED FURNITURE**

Please refer to the Lounge Booklet provided to you at time of order. This booklet contains comprehensive details on caring and cleaning of leather lounges, natural characteristics of leather, normal wear and tear of leather lounges and other important information. The information provided in this booklet forms part of this document relating to leather lounges.

#### **FABRIC UPHOLSTERED FURNITURE**

If thread becomes loose on the fabric, simply cut it off. Do not pull it. Dust is best removed using your vacuum cleaner with the appropriate attachment. Avoid harsh brushing and sharp objects (rings, buckles, toys) as it will cause snagging of threads. Do not allow cats and dogs to walk on fabric upholstered furniture. As many fabrics differ in properties, it is best to follow the unique care and cleaning instructions labelled on your fabric furniture.

#### **LACQUERED AND TIMBER FINISHES**

Natural timber and veneer finishes will show distinctive markings, patterns and colour variations which are evidence of being produced from genuine timber materials. Always use protective heat coverings to protect against hot objects. A tablecloth is not sufficient. Always use coasters when placing glasses, bottles or cups on the surface. Regularly clean surface by wiping with a non-abrasive, damp cloth.

#### **MARBLE, TRAVERTINE AND MACSTONE FINISHES**

Marble and Travertine are natural materials. Each piece is unique in markings and patterns and colour variation. Always use protective heat coverings to protect against hot objects. A tablecloth is not sufficient. Always use coasters when placing glasses, bottles or cups on the surface. Any liquid spills should be wiped clean immediately. Remove dirt and dust by wiping with a warm, damp cloth.

#### **CHROME & METAL FINISHES**

Dust the surface regularly to avoid build up of pollutants, which may cause the surface to rust. Only use a recognized brand of chrome

polish, if necessary. Avoid contact with sharp or hard objects as this will cause scratching.

#### **GLASS**

Use a regular glass cleaner with an appropriate soft cloth for glass. Do not apply glass cleaner to surrounding areas or the frosted side of the glass. Always use a mat to avoid hot objects being in direct contact with glass. Avoid contact with sharp or hard objects as this will cause scratching. Never lift glass tops from the ends of a table as this will put unnecessary stress on the surface and may cause it to break

#### **BATTERIES**

The lifetime of any Battery Pack supplied with our products is 12 months from the date of purchase. We strongly recommend that you replace and do not use the Battery Packs for longer than 12 months after the date of purchase – doing so presents an increased safety hazard, including the increased risk of fire. Battery care instructions can be found at [fabbfurniture.com/cleaning-and-care-guidelines](http://fabbfurniture.com/cleaning-and-care-guidelines)

# Keeping in touch & delivery information

We will be in touch prior to the arrival of your lounge with an estimated arrival date. You can also track the progress of your lounge at any time via [payments.fabbfurniture.com](https://payments.fabbfurniture.com).

Our Distribution Centres are designed to receive and deliver items as efficiently as possible to get your new furniture to you as quickly as possible. As such, our Distribution Centre isn't optimised for long-term storage. All Custom-Made deliveries must occur within 21 days of receipt.

Once we have a projection on the earliest possible delivery date, we will contact you with a tentative booking date. Please note that we cannot deliver your furniture with an outstanding balance, and suggest finalising your balance as soon as possible to avoid any delays to your tentative booking date.

You can finalise your balance in-store, or easily via the website at [payments.fabbfurniture.com](https://payments.fabbfurniture.com).

After this initial contact, we will reach out again to confirm the delivery date. Our distribution team optimise our delivery route to ensure we can deliver as many orders to our customers, as promptly as possible.

Once you have accepted your delivery date please ensure you are available on that day to receive delivery. As our team will assemble and place your furniture, they cannot leave goods unattended. Please note any packaging will be your responsibility, as our delivery team cannot take it with them. All delivery fees are paid on the day of delivery to our delivery technicians.

The day prior to your delivery our team will be in contact to give you an approximate 3-4 hour delivery window for your convenience.

September 2024

A000000

 **furniture**