

Kenmore®/MD



Super-Automatic Coffee Machine with Dual Cream System



KKSACM-B



KKSACM-W

Use & Care Guide

SAFETY INSTRUCTIONS

Intended Use

The following safety guidelines are intended to prevent unforeseen risks or damage from unsafe or incorrect operation of the appliance. Please check the packaging and appliance on arrival to make sure everything is intact to ensure safe operation. If you find any damage, please contact the retailer or dealer. Please note modifications or alterations to the appliance are not allowed for your safety concern. Unintended use may cause hazards and loss of warranty claims.

Explanation of Symbols

Danger



This symbol indicates that there are dangers to the life and health of persons due to extremely flammable gas.

Warning of electrical voltage



This symbol indicates that there is a danger to life and health of persons due to voltage

Warning



The signal word indicates a hazard with a medium level of risk which, if not avoided, may result in death or serious injury.

Caution



The signal word indicates a hazard with a low degree of risk which, if not avoided, may result in minor or moderate injury.

Attention



The signal word indicates important information (e.g. damage to property), but not danger.

Observe instructions



This symbol indicates that a service technician should only operate and maintain this appliance in accordance with the operating instructions

Read these operating instructions carefully and attentively before using/commissioning the unit and keep them in the immediate vicinity of the installation site or unit for later use!

IMPORTANT SAFEGUARDS

Warning

When using electrical appliances, basic safety precautions should always be followed including the following:

- Read all instructions

IMPORTANT SAFEGUARDS

- Do not operate any appliance with a damaged cord or plug or after the appliance malfunctions or has been damaged in any manner. Return appliance to the nearest authorized service facility for examination, repair, or adjustment. Customer Assistance 1-800-265-8456
- To protect against fire, electrical shock and injury to persons do not immerse cord, plugs, or other live parts in water or other liquid.
- Do not touch hot surfaces. Use handles or knobs.
- Scalding may occur if the lid is removed during the brewing cycles.
- Do not use outdoors. Household use only.
- Close supervision is necessary when any appliance is used by or near children.
- Do not use appliance for other than intended use.
- Unplug from outlet when not in use and before cleaning. Allow to cool before putting on or taking off parts, and before cleaning the appliance.
- The use of accessory attachments not recommended by the appliance manufacturer may cause injuries.
- Do not let cord hang over edge of table or counter, or touch hot surfaces.
- Do not place on or near a hot gas or electric burner, or in a heated oven.
- To disconnect, turn all controls to "off", then remove plug from wall outlet.
- To reduce the risk of injury, do not drape cord over the counter top or table top where it can be pulled on by children or tripped over unintentionally.
- A short power-supply cord is provided to reduce the risk resulting from becoming entangled in or tripping over a longer cord.
- This appliance is not intended for use by persons (including children) with reduced physical, sensory or mental capabilities, or lack of experience and knowledge, unless they have been given supervision or instruction concerning use of the appliance by a person responsible for their safety. Children should be supervised to ensure that they do not play with the appliance.
- Turn the appliance OFF, then unplug from the outlet when not in use, before assembling or disassembling parts and before cleaning. To unplug, grasp the plug and pull from the outlet. Never pull from the power cord.
- Avoid contacting moving parts. Do not attempt to defeat any safety interlock mechanisms.
- Check hopper for presence of foreign objects before using.
- Extension cords are available and may be used if care is exercised in their use.
- If a long extension cord is used:
 - 1) The marked electrical rating of the extension cord should be at least as great as the electrical rating of the appliance;
 - 2) the extension cord should be a grounding-type 3-wire cord;
 - 3) The longer cord should be arranged so that it will not drape over the counter top or table top where it can be pulled on by children or tripped over.

SAVE THESE INSTRUCTIONS

PRODUCT OVERVIEW

Components

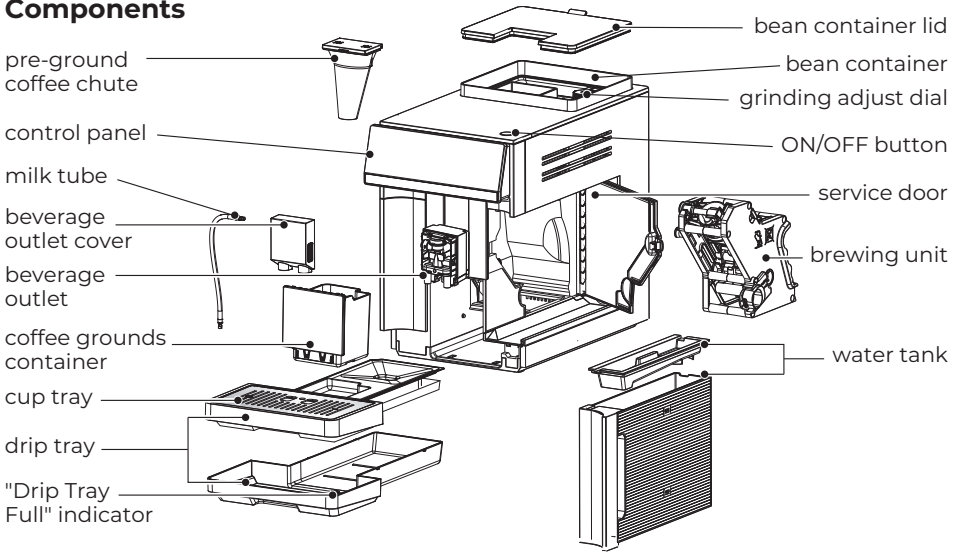

Accessories



milk container



water filter

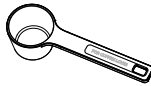

measuring scoop

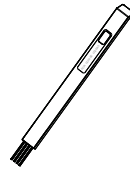

cleaning brush

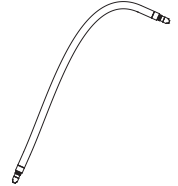

milk tube



cleaning cloth



water hardness test strip













NOTE

- Fragile parts: water tank, brewing unit
- All the pictures in this manual are for explanation purpose only. Any discrepancy between the real object and the illustration in the drawing shall be subject to the real subject.
- Remove parts from the component before performing installation.

PRODUCT OPERATION

HOW TO USE



| ICON | DESCRIPTION |
|--|------------------------------------|
|  | • Water tank icon |
|  | • Coffee grounds container full |
|  | • Error icon |
|  | • Coffee bean container empty icon |
|  Filter | • Water filter icon |
| Clean & Calc | • Clean&Calc icon |
|  Clean & Calc | • Milk system cleaning reminder |
|  Clean & Calc | • Descaling reminder |
|  | • Double cup icon |
|  | • Drink volume icon |
|  | • Coffee strength icon |
|  | • Milk volume icon |
|  | • Start/Cancel |

PRODUCT OPERATION

1 INITIAL USE

- Remove any protective plastic films and stickers.

1.1 SETTING UP THE MACHINE

NOTE - Choose a spot which protects the machine against overheating; ensure that the ventilation slots are not covered. Only use the machine in a frost-free room; if it has been transported or stored at temperature below 0°C, wait at least 3 hours before setting it up.

- Remove the water tank, rinse it and fill it with fresh and filtered water up to the "max" mark.
- Replace the water tank and insert in place.
- Remove the bean container lid.
- Remove any dirt or foreign objects from inside the bean container.
- Fill the bean container only with coffee beans and close the lid.
- Insert the power plug into a socket.

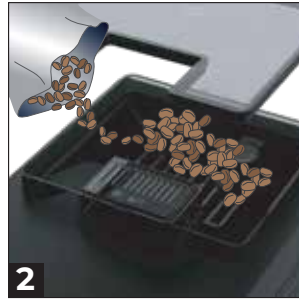
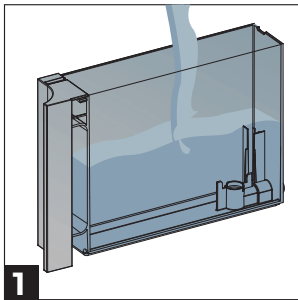

1.2 DETERMINING THE WATER HARDNESS - First time use

When you use the machine for the first time, it is important to set the water hardness correctly to enable the machine to accurately indicate when the descaling programme should be run.

- Use the enclosed test strip to determine the water hardness.
- Briefly dip the test strip in water for 2 seconds.
- Hold the strip horizontally for 10 seconds.
- Check the degree of water hardness from the discoloration of the test strip.

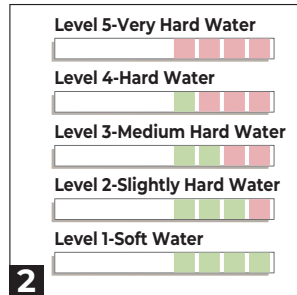
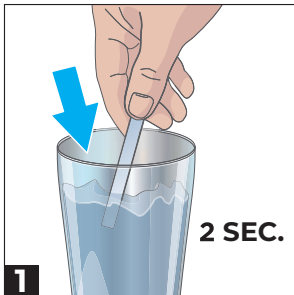

PRODUCT OPERATION

NOTE - Water hardness default setting is level 5 - Very Hard Water.

- Press the On/Off power button to switch the machine on.
- Coffee strength icon light goes on.

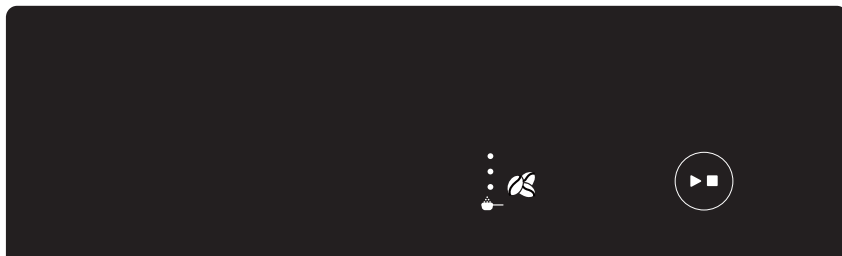

- Check the degree of water hardness from the discoloration of the test strip.
- When there is no red square shown on the water hardness test strip, please select with level 1 - soft water.
- Tap the coffee strength icon to choose corresponding water hardness level.
- Press Start/Cancel icon to confirm.
- The machine will start heating up and perform the automatic rinsing cycle
- During heating up, the lights in the drink icons light up and go out slowly one by one.

| ICON | DESCRIPTION |
|------|----------------------|
| | • Level 5 (>21° dH) |
| | • Level 4 (>14 ° dH) |
| | • Level 3 (>7 ° dH) |
| | • Level 2 (>4 ° dH) |
| | • Level 1 (<3 ° dH) |

1.3 GENERAL

• The machine will start heating up and perform the automatic rinsing cycle every switch-on.

- During heating up, the lights in the drink icons light up and go out slowly one by one.

NOTE - Hot water will be dispensed from beverage outlet when machine is in automatic rinsing.

• When all lights in the drink icons light up continuously, the machine is ready to use (beverage selection mode).

- The Clean&Calc icon lights up. You can tap to choose milk system cleaning, or long-press 2.5 seconds to choose descaling function (see chapter “CLEANING AND MAINTENANCE”).

PRODUCT OPERATION



- The machine will switch off and perform the automatic rinsing cycle after 30 minutes of last drink brewed.
- Machine will perform the automatic rinsing cycle when switching off if coffee or milk beverages have been brewed.

TIP - When the machine is used for the first time after running a rinsing service program, or if it has not been operated for a long period, the first beverage will not have the full aroma and should not be consumed.

2 PREPARING DRINKS

- For double cup settings, coffee is prepared in two stages, please wait until the process is completely finished.
- Steam will be generated and discharging during beverages brewing, it's normal that there is steam or condensation on the lid surface of pre-ground coffee chute and vent slots.

NOTE - Hot coffee, hot steam and hot water can cause scalding.

2.1 PERSONALIZING DRINKS



· This machine allows you to adjust the settings of a drink to your own preference. After selecting a drink you can:





- Adjust the drink quantity by tapping the drink volume icon and/or the milk volume icon (specific types only). There are 3 volumes selectable: low, medium and high.
- Adjust the aroma strength by tapping the strength icon. There are 3 strengths, one-dot is the mildest and three-dot is the strongest.

NOTE - You can also adjust the coffee temperature to your own preference (see chapter "ADJUSTING DRINK TEMPERATURE")

| ICON | DESCRIPTION |
|------|--------------|
| | · Large cup |
| | · Medium cup |
| | · Small cup |
| | · Double cup |

PRODUCT OPERATION

| ICON | DESCRIPTION |
|---|----------------------|
|  | · Max. milk volume |
|  | · Normal milk volume |
|  | · Less milk volume |

| ICON | DESCRIPTION |
|---|---------------------|
|  | · Strong |
|  | · Medium |
|  | · Mild |
|  | · Pre-ground coffee |

2.2 PREPARING DRINKS WITH BEANS

· Place a cup underneath the beverage outlet, and you can slide the beverage outlet up or down to adjust its height.



- To brew a coffee, press the coffee drink icon of your choice.
 - The aroma strength and quantity lights go on and shows the previously selected settings.
 - You can now adjust the drink to your preferred taste (see chapter "PERSONALIZING DRINKS")
- To brew 2 drinks at the same time, tap the double cup icon, the double cup light goes on.

NOTE - Double cup option is not available for the drink Americano.

PRODUCT OPERATION



- Press the start/cancel button.
 - The light in the start/cancel button dims and brightens while the drink is being dispensed.

NOTE - Specific types only - an Americano is made of Espresso and water; when you brew an Americano, the machine first dispenses an Espresso and then hot water.

- To stop dispensing drink before the machine is finished, press the start/cancel button.
 - If the machine is interrupted during beverage brewing, it will perform a self-checking cycle.
- When brewing is finished, the machine will be in beverage selection mode.

2.3 PREPARING MILK-BASED DRINKS

This fully automatic coffee machine has an integrated beverage outlet. This can be used to prepare coffee drinks with milk or also milk froth.

- Connect one end of milk tube to the beverage outlet.
- Insert another end of the milk tube in the milk container or a milk carton.
- Fill milk container with milk, do not fill the container beyond the maximum indication.

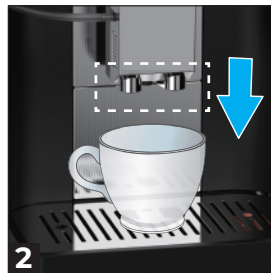

TIP - Use cold milk directly from the fridge for optimal results.

- Press the milk-based drink icon of your choice.
 - The aroma strength, coffee quantity and milk volume lights go on and shows the previously selected settings.
 - You can now adjust the drink to your preferred taste (see chapter "PERSONALIZING DRINKS").

PRODUCT OPERATION



- To brew 2 drinks at the same time, tap the double cup icon, the double cup light goes on.
- Press the start/cancel button.
 - The light in the start/cancel button dims and brightens while the drink is being dispensed.
- You can press start/cancel to stop milk/milk froth and coffee dispensing.
 - If the machine is interrupted during beverage brewing, it will perform a self-checking cycle.
- When brewing finished, the milk system cleaning reminder will go on with the upper left icon flashing.
 - Milk system cleaning is suggested when every milk beverage finished.



2.4 Preparing drinks with pre-ground coffee

NOTE

- Never add pre-ground coffee when the machine is off or it could spread through the inside of the machine and make it dirty. This could damage the machine.
- You can choose to use pre-ground coffee instead of beans, for example if you prefer a different coffee variety or decaffeinated coffee.

- Press the On/Off power button to switch the machine on.
- Place a cup underneath the beverage outlet.
- Open the lid of the pre-ground coffee chute and pour no more than one spoon of pre-ground coffee into it. Close the lid.
- If more than one spoon of pre-ground coffee is used, it could soil the inside of the coffee machine or block the coffee chute.

- Select the coffee drink icon of your choice.
- Tap the aroma strength icon to pre-ground coffee mode.
 - The pre-ground coffee light goes on.
- You can now adjust the drink volume or milk volume (if milk-based beverage is selected).



PRODUCT OPERATION



- Press the start/cancel button.
 - The light in the start/cancel button dims and brightens while the drink is being dispensed.
- To stop dispensing coffee before the machine is finished, press the start/cancel button.
 - If the machine is interrupted during beverage brewing, it will perform a self-checking cycle.
- When brewing is finished, the machine will be in beverage selection mode.

NOTE - When using ground coffee, the option for dispensing two cups at once is not available.

2.5 DISPENSING HOT WATER

- Place a cup underneath the beverage outlet.
- Press the hot water icon.
 - The drink volume light goes on and show the previously selected drink setting for hot water.
- Adjust the hot water volume to your preference by tapping the drink volume icon.

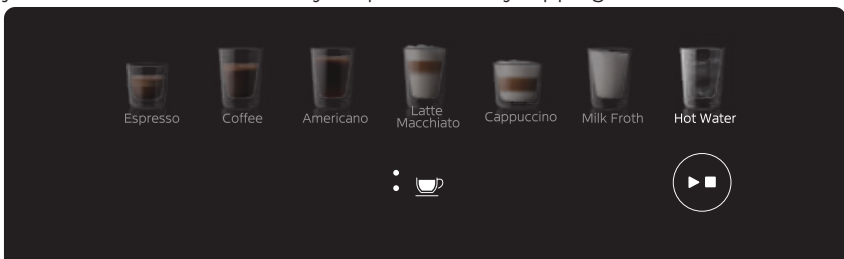

- Press the start/cancel button.
- The light in the start/cancel button dims and brightens while the drink is being dispensed.
 - To stop dispensing coffee before the machine is finished, press the start/cancel button.
 - When brewing is finished, the machine will be in beverage selection mode.

PRODUCT OPERATION

2.6 EXTRACTION GUIDANCE

Depending on your choice of beans, you might need to adjust the grinder setting to a finer or more coarse choice.

1. PERFECT ESPRESSO

- Flowing like warm honey, nut-brown crema, well balanced and lingering taste.

2. UNDER EXTRACTED

- Flowing fast like water, light and pale crema.
To make it perfect: adjust grinding setting to a finer setting and select a higher strength.

3. OVER EXTRACTED

- Flowing in drips or not at all, crema very dark and not uniform.
To make it perfect: adjust grinding setting to a coarser setting and select a lower strength.



TIP!
Keep the grind size adjustment.



TIP!
Turn counterclockwise for a finer grind size.



TIP!
Turn clockwise for a coarser grind size.

PRODUCT OPERATION

3. ADJUSTING MACHINE SETTINGS

3.1 PARAMETER SETTING MODE

- The machine must be ready to use (in beverage selection mode).
- Long press Latte Macchiato and Milk Froth icons at the same time for three seconds to enter parameter setting mode.
 - The water filter and Clean&Calc icons are at 50% brightness. Drink volume, coffee strength and milk volume icons are at 100% brightness..

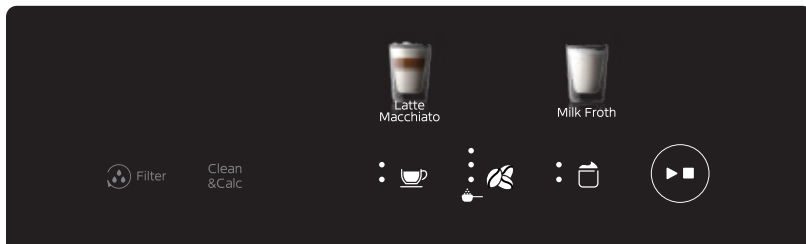

3.2 ADJUSTING DRINK TEMPERATURE

- Machine must be in the parameter setting mode.
- Tap the drink volume icon to select the required coffee temperature: normal, high or max.
 - Respectively 1, 2 or 3 lights are on.

| ICON | DESCRIPTION |
|------|----------------------|
| | · Max. temperature |
| | · High temperature |
| | · Normal temperature |

- Tap the milk volume icon to select the required hot water temperature: normal, high or max.
 - Respectively 1, 2 or 3 lights are on.





| ICON | DESCRIPTION |
|------|----------------------|
| | · Max. temperature |
| | · High temperature |
| | · Normal temperature |

- When drink temperature settings finished, press start/cancel button to save the settings.
- Machine goes back to beverage selection mode.

PRODUCT OPERATION

3.3 SETTING THE WATER HARDNESS

- Check the degree of water hardness from the discoloration of the test strip. (See chapter "DETERMINING THE WATER HARDNESS")
- Machine must be in the parameter setting mode.
- Tap the coffee strength icon to choose corresponding. water hardness level, when there is no red square shown on the water hardness test strip, please select with level 1 – soft water.

| ICON | DESCRIPTION |
|---|----------------------|
|  | • Level 5 (>21° dH) |
|  | • Level 4 (>14 ° dH) |
|  | • Level 3 (>7 ° dH) |
|  | • Level 2 (>4 ° dH) |
|  | • Level 1 (<3 ° dH) |

- When you have set the correct water hardness, press start/cancel button to save the setting.
- Machine goes back to beverage selection mode.

NOTE - Since you only set the water hardness once, the aroma strength function is used to select the water hardness. This does not affect the aroma strength of drinks you make afterwards.

3.4 RESTORING SETTINGS

- Machine must be in the parameter setting mode.
- Long press Latte Macchiato and Milk Froth icons at the same time for three seconds.
- All parameters will be reset to default settings.

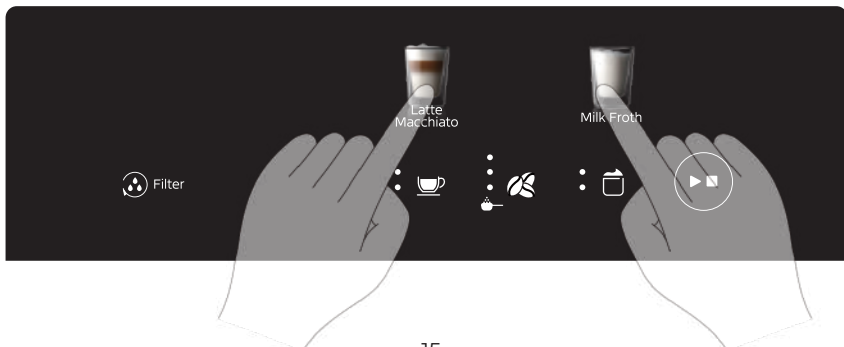

PRODUCT OPERATION

3.5 SETTING THE STANDBY TIME

- Press the Espresso and Americano icon simultaneously for 3 seconds. The Espresso and Americano icon light up.

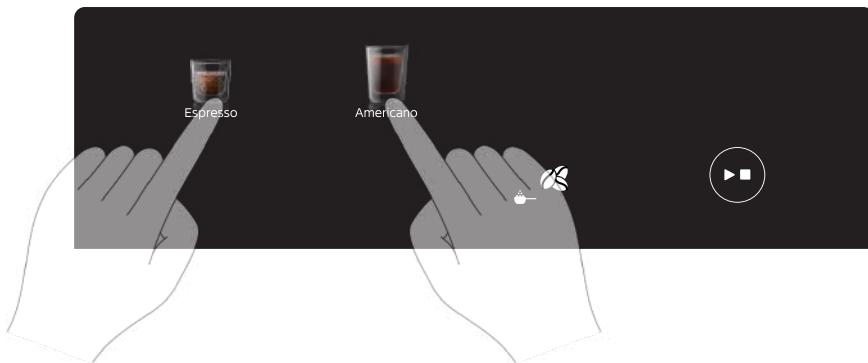

- Tap coffee strength icon repeatedly until the control panel shows the required standby time. Available standby settings:

| ICON | DESCRIPTION |
|---|-------------|
|  | · 15 min |
|  | · 30 min* |
|  | · 1 hr |
|  | · 2 hr |
|  | · 3 hr |

*Factory setting

- To save the setting, press Start/Cancel button. Machine goes back to beverage selection mode.

PRODUCT OPERATION

4. WATER FILTER

A water filter can lessen limescale deposits, reduces impurities in water and improves the coffee taste.

4.1 ACTIVATING THE WATER FILTER

The machine does not automatically detect that a filter has been placed in the water tank. Therefore you need to active each new water filter that you install with water filter icon.

NOTE - Before activating the water filter, it has to be prepared by soaking it in water as described below. If you don't do this, air might be drawn into the machine instead of water, which prevents the machine from being able to brew coffee.

- Shake the filter for about 5 seconds.
- Remove the filter from the packaging and turn the date indicator to view the next 2-3 months.
- Run tap water into through the hole in the centre of the filter until water comes out of the openings at the side for more than a minute.
- Immerse the filter upside down in a jug with cold water and shake it for 10 seconds.
- Insert the filter vertically onto the filter connection in the water tank. Press it down to the lowest possible point.
- Fill the water tank with fresh and filtered water.

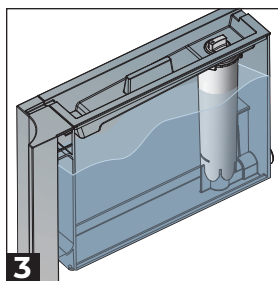
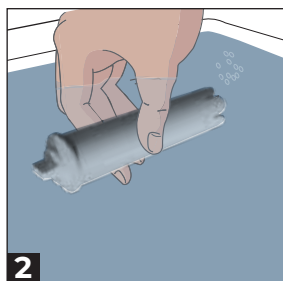

- The machine must be ready to use (in beverage selection mode).
- Long press Latte Macchiato and Milk Froth icons at the same time for three seconds to enter parameter setting mode.
 - The water filter icon is at 50% brightness (the water filter is not activated).

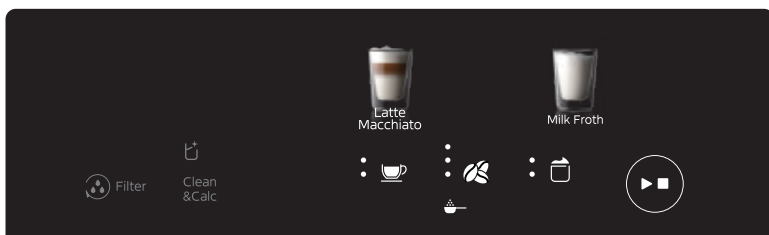

PRODUCT OPERATION

- Press the water filter icon, the icon is at 100% brightness.
- Press the Start/Cancel button. Machine performs an automatic rinsing cycle.
 - The lights in the drink icons light up and go out slowly one by one.
- When the activation process is finished, the water filter icon light goes off to confirm that the filter has been activated correctly.

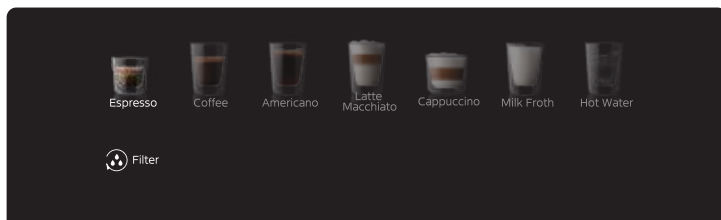

4.2 REPLACING THE WATER FILTER

The filter is no longer effective when the water filter icon starts to flash to remind you to replace the filter, or at the latest after 3 months. It needs to be replaced for reasons of hygiene and to prevent a build-up of limescale.

- The water filter icon flashes.
- Take out the old water filter.
- Install a new filter and activate it as described in chapter ACTIVATING THE WATER FILTER.



NOTE - The water filter icon is flashing when you enter the parameter setting mode. To replace and active a new water filter, press the water filter icon to 100% brightness and start the activation.

4.3 TURN OFF THE WATER FILTER REMINDER

When the water filter icon flashes to remind you of replacement, and you do not want to replace the water filters, you can turn off the water filter reminder.

- The water filter icon flashes.
- Take out the old water filter.
- Enter the parameter setting mode. See chapter PARAMETER SETTING MODE.
- Press the flashing water filter icon to 50% brightness. Press the tart/Cancel button.
- The machine returns to the beverage selection mode. The water filter icon light goes off.

In that case you can still replace the water filter. Install a new filter and activate it as described in chapter ACTIVATING THE WATER FILTER.

CLEANING AND MAINTENANCE

1. CLEANING PROGRAMME

1.1. MILK SYSTEM CLEANING PROGRAMME

- When milk-based beverage is brewed.
 - The milk system cleaning reminder will light up with the upper left icon flashing.
 - Milk system cleaning is suggested when every milk beverage finished.
- Remove the milk tube from milk container, wipe it and insert the end of the suction pipe into the hole on the cup tray.

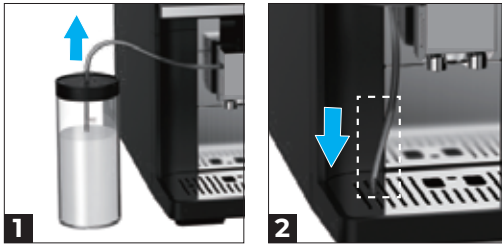

- Tap the Clean&Calc icon to choose the milk system cleaning function.
 - The milk system cleaning reminder will light up with the upper left icon flashing.
- Press the start/cancel button.
 - The light in the start/cancel button dims and brightens during milk system rinsing.
- When cleaning is finished, the machine will be in beverage selection mode.

NOTE - During milk system rinsing, a small amount of water will be discharged from milk tube.



1.2 COFFEE CLEANING PROGRAMME

- Long press Latte Macchiato and Milk Froth icons at the same time for three seconds to enter parameter setting mode. The Clean&Calc icon is at 50% brightness.
- Remove the milk tube and clean it.
- Tap the Clean&Calc icon, the Clean&Calc icon and milk system cleaning reminder icon are at 100% brightness.

CLEANING AND MAINTENANCE

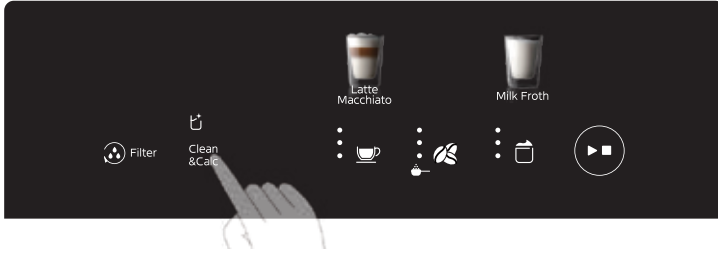

- To start the coffee cleaning programme, press the Start/Cancel button.
- The "coffee grounds container full" is flashing.
- Remove and empty the drip tray and the coffee grounds container.
- Insert the drip tray and the coffee grounds container.
- The "water tank empty" icon is flashing.
- Remove and fill the water tank with lukewarm water up to the MAX mark.
- Insert the water tank.
- Place a container with a capacity of at least 1.5 litres under the beverage outlet.
- Put a cleaning tablet into the pre-ground coffee chute.
- To resume the coffee cleaning programme, press the Start/Cancel button. The Clean&Calc and "milk system cleaning reminder" icons will dim and brighten during the cleaning programme.
- The "coffee grounds container full" is flashing.
- Remove and empty the drip tray and the coffee grounds container.
- Insert the drip tray and the coffee grounds container.
- When the coffee cleaning programme is finished, the appliance returns to beverage selection mode.

NOTE

- The coffee cleaning programme takes about 20 minutes.
- The coffee cleaning programme can not be canceled once it starts.

1.3. DESCALING PROGRAMME

- The 'descaling reminder' icon is flashing to remind you to descale the machine.
- Remove the milk tube and clean it.
- Press the Clean&Calc icon for 3 seconds. The "descaling reminder" icon lights up.
- To start the descaling programme, press the Start/Cancel button.



CLEANING AND MAINTENANCE

- The “coffee grounds container full” is flashing.
 - Remove and empty the drip tray and the coffee grounds container, then reinsert them.
- The “water tank empty” icon is flashing. If the water filter is activated, the water filter icon will also be flashing at the same time.
 - Remove the water tank and empty it. Remove water filter, if you are using one.
 - Fill the water tank with lukewarm water up to the 1L mark. Fill the descaler into the water tank according to the instructions on the packaging. Insert the water tank.
- Place container with a capacity of at least 1.5 litres under the beverage outlet.
- Insert one end of the milk tube into the beverage dispenser and the other end into the container.
- Press the “Start/Cancel” button to start the descaling programme. The Clean&Calc icon and “descaling reminder” icon will dim and brighten during the descaling programme.
- When the “water tank empty” icon is flashing, empty and rinse the water tank thoroughly.
- The water filter is flashing if you are using one. Insert the water filter into the water tank.
- Fill the water tank with cold, fresh, non-carbonated drinking water up to the MAX mark and reinsert it.
- To resume the descaling programme, press the Start/Cancel button. The Clean&Calc and “descaling reminder” icons will dim and brighten during the rinsing process.
- The “coffee grounds container full” is flashing.
 - Remove and empty the drip tray and the coffee grounds container, then reinsert them.
- When the descaling programme is finished, the machine returns to the beverage selection mode.

WARNING!

- Do not drink dispensed liquids!

NOTE

- The descaling programme runs for about 40 minutes.
- The descaling programme cannot be stopped once it starts.
- Machine can still brew some drinks when descaling icon lights up. If the machine is not descaled when it is supposed to be, the machine will be locked, only showing the Clean&Calc and “descaling reminder” icons. Immediately perform the descaling process in accordance with the instructions.

2. CARE AND DAILY CLEANING

CAUTION!

- To prevent damage to the appliance do not use alkaline cleaning agents when cleaning, use a soft cloth and a mild detergent.
 - Never immerse the machine in water.
 - Do not steam-clean the machine.
-
- Remove the drip tray and coffee grounds container.
 - Wipe the inside of the machine with a soft cloth.
 - Do not use any cleaning agents containing alcohol.
 - Do not use abrasive cloths or cleaning agents.

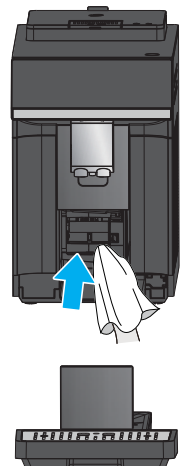

CLEANING AND MAINTENANCE

The following parts can be cleaned in the dishwasher:

- drip tray container
- drip tray cover
- coffee ground container
- milk tube
- beverage outlet

3. DRIP TRAY AND COFFEE GROUNDS CONTAINER CLEANING

Empty the drip tray daily or as soon as the orange "drip tray full" indicator pops up through cup tray.

Empty coffee grounds container when "coffee grounds container full" icon is flashing.

- Pull the drip tray out forwards.
- Remove drip tray cover and coffee grounds container.
- Empty, rinse, clean and dry individual parts.
- Replace the dried parts.

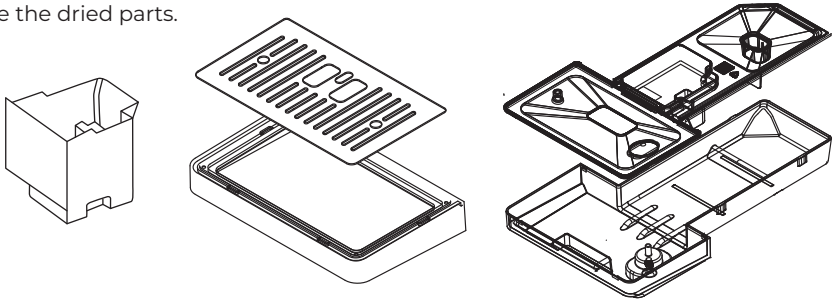

4. MANUAL MILK SYSTEM CLEANING

- Pull the outlet cover forward to remove.
- Uplift the limited spring to the groove.
- Pull the beverage outlet forward completely to remove.

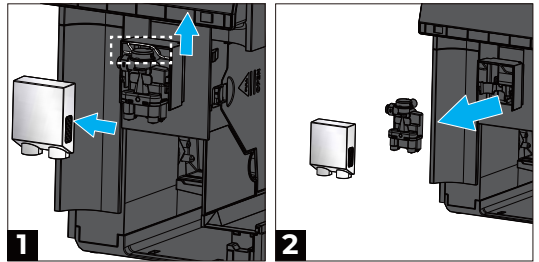

- Remove the milk tube.
- Dismantle the top and bottom sections of the beverage outlet.

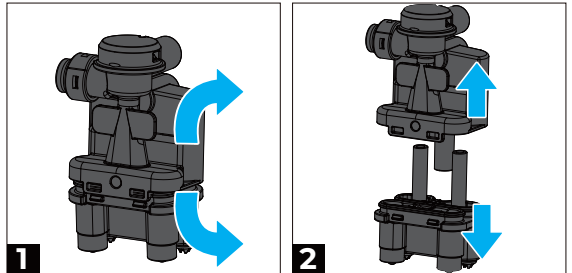

CLEANING AND MAINTENANCE

- Clean all the individual parts under the tap with lukewarm water.
- Put the individual outlet parts back together again.
- Attach the beverage outlet directly from the front firmly for the four connections.
- Replace the cover.

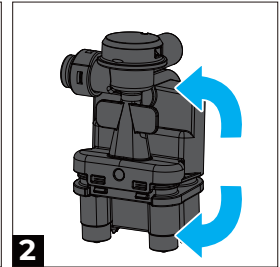
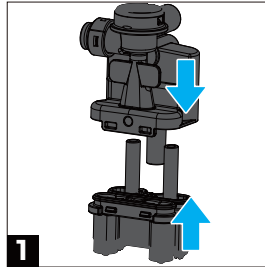

5. CLEANING THE BREWING UNIT

In addition to the automatic rinsing programme, the brewing unit should be removed for cleaning weekly.

- Switch off machine.
- Remove the water tank and open the service door.

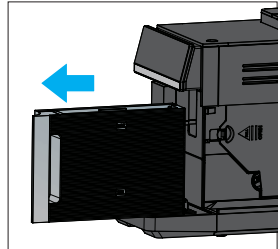

- Press the brewing unit orange knob towards PUSH arrow direction to end position and hold at the recessed grips of the brewing unit to remove it from the machine.
- Clean brewing unit thoroughly under the water jet.

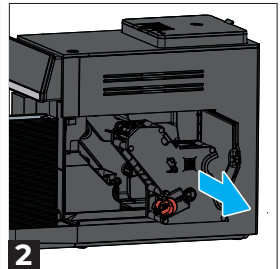
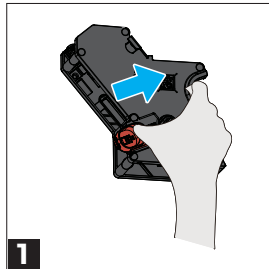

NOTE - Do not use any soap or cleaning agents! Do not put the brewing unit in the dishwasher in the dishwasher.

- Clean the inside of the machine thoroughly with a moist cloth.
- Leave the brewing unit and the inside of the machine to dry.
- Slide the brewing unit back into the machine along the guiding rails on the sides and press it until it audibly clicks into place.

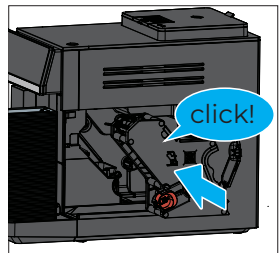





















TROUBLESHOOTING

Operation of your appliance can lead to errors and malfunctions. The following tables contain possible causes and notes for resolving an error message or malfunction. It is recommended to read the tables below carefully in order to save your time and money that may cost for calling to the service center.

TROUBLESHOOTING

1. DISPLAY MESSAGE

| Warning icons | Solution |
|---|---|
|   | <ul style="list-style-type: none"> · The "error" icon light is flashing in red and the "Espresso" icon is on. · The brewing unit is blocked. Disconnect the power and wait for at least 5 seconds before powering on the machine again. · If the machine does not return to the beverage selection mode, please do not brew any drinks and contact Kenmore Customer Assistance. |
|   | <ul style="list-style-type: none"> · The "error" icon light is flashing in red and the "Coffee" icon is on. · There is an error in the water circuit. Make sure to properly insert the water tank and fill it with fresh water up to the MIN level. Disconnect the power and wait for at least 5 seconds before powering on the machine again. · If the machine does not return to the beverage selection mode, please do not brew any drinks and contact Kenmore Customer Assistance. |
|       | <ul style="list-style-type: none"> · The "error" icon light is flashing in red and the drink icon is on. Please do not brew any drinks and contact Kenmore Customer Assistance. |
|  (flashing) | <ul style="list-style-type: none"> · The "water tank" icon light is flashing. · The water tank is almost empty. Fill the water tank with fresh water to the maximum level indication. |
|  | <ul style="list-style-type: none"> · The "water tank" icon light is on. · The water tank is not in place. Place back the water tank. |
|  (flashing) | <ul style="list-style-type: none"> · The "coffee grounds container full" icon light is flashing. · The coffee grounds container is full. Empty and replace the coffee grounds container while machine is on. Wait at least 5 seconds before reinserting the container. |
|  | <ul style="list-style-type: none"> · The "coffee grounds container full" icon light is on. · The coffee grounds container is not in place. Place back the coffee grounds container. |
|  (flashing) | <ul style="list-style-type: none"> · The "error" icon light is flashing in white. · Too much or too little coffee has been used. Take out the brewing unit and rinse under tap water. |
|  | <ul style="list-style-type: none"> · The "error" icon lights up in white. The brewing unit is not in place or not placed in position. Remove the brewing unit and make sure it is inserted correctly. See chapter CLEANING THE BREWING UNIT for instruction. |
|  (flashing) & Calc | <ul style="list-style-type: none"> · The "milk system cleaning reminder" icon light is on, with the upper left icon flashing. · Rinse the milk system, see chapter MILK SYSTEM CLEANING PROGRAMME for instruction. |
|  (flashing) & Calc | <ul style="list-style-type: none"> · The "descaling reminder" icon light is on, with the upper right icon flashing. · Descale the machine, see chapter DESCALING PROGRAMME for instruction. |
|  Filter | <ul style="list-style-type: none"> · The "water filter" icon light is flashing. · The water filter needs to be replaced. See chapter REPLACING THE WATER FILTER for instruction. |
|  (flashing) | <ul style="list-style-type: none"> · The "coffee bean container empty" icon light is flashing. · The bean container is almost empty. Fill the bean container only with roasted beans. |

TROUBLESHOOTING

2. Troubleshooting table

This chapter summarizes the most common problems you could encounter with the coffee machine.

| Problem | Possible causes | Solution |
|--|--|--|
| The water tank icon light remains flashing despite the water level being above minimum volume. | Float is stuck in the water tank. | Remove the water tank and clean thoroughly. |
| | Air in the water filter. | Rinse and soak the water filter according to the instructions in chapter ACTIVATE THE WATER FILTER. |
| The appliance does not turn on. | It is not plugged in. | Plug into the power outlet and push the power button. |
| The 'coffee grounds container full' icon light remains flashing despite the container being empty. | The container was emptied while the machine was off. | Always empty the coffee grounds container while the machine is switched on. Remove the coffee grounds container, wait at least 5 seconds and re-insert the container. |
| The coffee grounds container is full and the 'coffee grounds container full' icon light did not go on. | You removed the drip tray over 5 seconds and without emptying the coffee grounds container. | Empty the coffee grounds container when you remove the drip tray even if it contains only a few coffee pucks. The coffee grounds counter will be reset to zero, re-starting to correctly count the coffee pucks. |
| The 'coffee grounds container full' icon light goes on even through the container is not full. | The machine did not reset the coffee grounds counter the last time you emptied the coffee grounds container. | Always wait 5 seconds when you take out the drip tray and place back the coffee grounds container. In this way the coffee grounds counter will be reset to zero. |
| Coffee does not come out of one or both spouts. | The beverage outlet is blocked. | Clean the coffee spouts with sponge or toothpick. |

TROUBLESHOOTING

| Problem | Possible causes | Solution |
|---|---|--|
| Drinks cannot be dispensed or coffee comes out slowly even in dripping. | The beverage outlet or one of the 4 connections are blocked. | See the chapter 'Milk system cleaning manually', clean and rinse the beverage outlet and the connections throughly. |
| | The coffee is ground too finely. | Use more coarsely ground coffee, or to access the grind size adjusting knob to get coarser coffee ground. The effect is visible only after delivering 3 coffees. See the chapter EXTRACTION GUIDANCE INSTRUCTIONS |
| | The brewing unit is dirty. | Remove the brewing unit and rinse it. |
| | The water filter is not prepared properly for installation. | Remove the water filter and try to brew a coffee again. If this works, make sure that you have prepared the filter properly before you place it back. See chapter ACTIVATE THE WATER FILTER for instruction. |
| | The machine circuit is blocked by limescale. | Descal the appliance according to the instruction, see the chapter DESCALING PROGRAMME. Always descale the machine when the descaling light starts to flash. |
| The drinks runs out and spraying at the entire outlet during dispensing. | The lower part of beverage outlet is missing or not properly assembled. | Attach the lower part, see the chapter MILK SYSTEM CLEANING MANUALLY for instruction. |
| Strongly fluctuating coffee or milk froth quality (e.g. fluctuation in beverage quantity) | Build-up of limescale in the appliance. | Descal the appliance according to the instruction, see the chapter DESCALING PROGRAMME. |

TROUBLESHOOTING

| Problem | Possible causes | Solution |
|--|--|--|
| Insufficient milk froth, none at all or the milk system is not taking in any milk. | Build-up of limescale in the appliance. | Descalc the appliance according to the instruction, see the chapter DESCALING PROGRAMME. |
| | The beverage outlet or one of the 4 connections are blocked. | See the chapter MILK SYSTEM CLEANING MANUALLY, clean and rinse the beverage outlet and the connections thoroughly. |
| | The type of milk is not suitable for frothing. | Different types of milk result in different amounts of froth and different froth qualities. Do not use milk that has already been boiled. We suggest: use cold milk with a fat content of at least 1.5%. |
| | The beverage outlet or the milk tube is not correctly assembled. | See the chapter MILK SYSTEM CLEANING MANUALLY, moisten the individual parts and put them together. |
| | The milk suction pipe is blocked. | Clean the milk tube. |
| Ground coffee sticks in the coffee funnel. | Pre-ground coffee chute is damp. | Remove the pre-ground coffee chute, clean and dry thoroughly. |
| | Ground coffee sticks together and cannot drop out. | Do not press the ground coffee firmly into the spoon. |
| The coffee grounds are not compact and are too wet. | The grinding setting is too fine or too coarse, or not enough ground coffee has been used. | Adjust the grinding unit to a coarser or finer setting, or use a full spoon of ground coffee. |
| The coffee grounds are loose and watery and in small amount of coffee powder. | Foreign objects got into the grinder. | If every cup of coffee with same loose and watery coffee grounds, and it tastes too weak, please contact the customer service center. |

TROUBLESHOOTING

| Problem | Possible causes | Solution |
|---|---|---|
| The coffee is weak or has no 'crema'. | The coffee bean is unsuitable. | Use coffee beans for espresso machines, a type of coffee with a higher proportion of robusta beans. |
| | Coffee beans not fresh. | The coffee pack has been opened for too long and has lost its taste. |
| | The coffee is ground too coarsely. | See the chapter EXTRACTION GUIDANCE instructions, to adjust the grinding unit to a finer setting. |
| | Coffee strength selected is too weak. | Raise the strength of the coffee, see the chapter PERSONALIZING DRINKS. |
| The coffee is not hot enough. | The temperature is set too low. | See the chapter EXTRACTION GUIDANCE instructions, to adjust the grinding unit to a finer setting. |
| | A cold cup reduces the temperature of the drink. | Preheat the cups by rinsing with hot water. |
| | Adding milk reduces the temperature of the drink. | Regardless of whether you add hot or cold milk, adding milk always reduces the temperature of the coffee. Preheat the cups by rinsing with hot water. |
| The water filter does not stay in position in the water tank. | Another water filter is trying to be installed instead of the correct water filter. | Only the water filter offered by the distributor fits the appliance. |
| | The rubber ring on the water filter is not in place. | Place back the rubber ring on the water filter. |

TROUBLESHOOTING

| Problem | Possible causes | Solution |
|---|---|---|
| Brewing unit service door cannot be properly closed. | Brewing unit is not placed in position. | Remove the brewing unit and make sure it is inserted correctly. See chapter CLEANING THE BREWING UNIT for instruction. |
| | There is excess ground coffee around the brewing unit area. | Remove the brewing unit and clean the around ground coffee. See chapter CLEANING THE BREWING UNIT for instruction. |
| Grinding level adjustment is stiff. | Too many beans in the grinding unit. | Dispensing a drink from coffee beans. Only make any subsequent changes to the grinding level in small steps. |
| The appliance seems to be leaking. | The drip tray is too full and has overflowed which makes it look like the appliance is leaking. | Empty the drip tray daily or as soon as the red 'drip tray full' indicator pops up through. |
| | The water tank is not fully inserted and air is drawn into the appliance. | Make sure the water tank is in the correct position: remove it and insert it again pushing it as far as possible. |
| | The appliance is not placed on a horizontal surface. | Place the machine on a horizontal surface so that the drip tray does not overflow and the red 'drip tray full' indicator works properly. |
| The appliance suddenly goes back to beverage selection mode. | Appliance is too hot. | Switch off appliance for 30 minutes. |
| The lights in the drink icons suddenly light up and go out slowly one by one during beverage brewing. | You removed the drip tray or water tank during beverage brewing. | It's the normal self-reset process for the appliance, you can brew beverage after the appliance goes back to beverage selection mode (When all lights in the drink icons light up continuously, the machine is ready to use). |

TROUBLESHOOTING

| Problem | Possible causes | Solution |
|--|---|---|
| Very frequent display that descaling is necessary. | Water hardness setting is too hard. | Insert water filter and configure settings accordingly in the menu. See chapter SETTING THE WATER HARDNESS to set the water hardness level. |
| The display only shows the descaling icon and other functions cannot be activated. | The machine is locked due to descale immediately needed. | See the chapter DESCALING PROGRAMME , following the instruction to descale the appliance immediately. |
| The appliance is making a loud noise. | It is normal that the appliance makes noise during grinding or brewing. | If the appliance starts to make a different kind of noise, clean the brewing unit. |
| | The water filter was not prepared properly and air is now drawn into the appliance. | Remove the water filter and try to brew a coffee again. If this works, make sure that you have prepared the filter properly before you place it back. See chapter ACTIVATE THE WATER FILTER for instruction. |
| | The water tank is not fully inserted and air is drawn into the appliance. | Make sure the water tank is in the correct position: remove it and insert it again pushing it as far as possible. |
| | There is not enough milk in the milk container during making milk beverage. | Add milk in the milk container. |
| Condensation in the pre-ground coffee chute cover or steam escaped from the vent slot. | It is normal that the appliance discharges steam. | You can open the pre-ground coffee chute cover during beverage making. |

TROUBLESHOOTING

| Problem | Possible causes | Solution |
|--|--|--|
| The bean container is empty but the "coffee bean container empty" icon light did not go on. | The oil from coffee beans have soiled the detection window in bean container. | Use the cleaning brush to clean the bean container detection window regularly. |
| The bean container still has beans but the "coffee bean container empty" icon light goes on. | Coffee beans stuck in the grinder protection grid in bean container. | Use the cleaning brush to push the coffee beans through. |
| The machine dispensed coffee liquid instead of hot water when performing switch-on automatic cleaning. | You added pre-ground coffee to the pre-ground coffee chute before turning on the coffee maker. | Do not put pre-ground coffee into the pre-ground coffee chute when the machine is off. |
| | Some coffee powder fell into the brewing unit. | Remove the brewing unit and clean the ground coffee. See chapter CLEANING THE BREWING UNIT for instruction. |
| The "water tank" icon remains flashing when switched off the machine. | The water in the water tank is not enough for the switch-off automatic rinsing. | Fill the water tank with fresh water to the maximum level indication, the machine will be off after performing an automatic rinsing. |

WARRANTY

2 Year Limited Warranty

FOR TWO YEARS from the date of sale this product is warranted against defects in material or workmanship.

WITH PROOF OF SALE a defective product will be repaired or replaced free of charge.

The Kenmore brand is used under license. Direct all claims for warranty service to Kenmore Customer Assistance, call 1-800-265-8456 or email KenmoreCustomerCare@KC.com

This warranty covers manufacturer's defects including electrical and mechanical defects provided the appliance is correctly assembled, operated and maintained according to the supplied instructions. It does not cover damage caused by accident, misuse or abuse including overheating, unauthorized repairs or alterations, or use with a voltage converter or aftermarket accessories, and it does not apply to scratches, stains, discoloration or other surface damage that does not impair the product function. This warranty is void if the appliance is ever used for purposes other than private household use.

Koolatron Corporation
4320 Federal Drive, Batavia, NY 14020 U.S.A.
139 Copernicus Blvd., Brantford, ON N3P1N4 Canada

Kenmore and the Kenmore logo are registered trademarks to Transform SR Brands LLC and are used under license by Koolatron Corporation