

# Kenmore<sup>®/MD</sup>



## Refrigerator

Top mount / 30" width / 18.1 cu. ft.



KKTMR30X18.1-B  
KKTMR30X18.1-SSL  
KKTMR30X18.1-W

Use & Care Guide

# TABLE OF CONTENTS

|  |       |                                    |       |
|--|-------|------------------------------------|-------|
| <b>PRUDUCT RECORD</b> .....                | 3     | <b>DOOR FEATURES</b> .....         | 19    |
| <b>WARRANTY</b> .....                      | 4     | Door Bins .....                    | 19    |
| <b>IMPORTANT SAFETY INSTRUCTIONS</b> ..... | 5-7   | Gallon Door Storage Bin .....      | 19    |
| <b>REFRIGERATOR SAFETY</b> .....           | 8-10  | <b>FOOD STORAGE GUIDE</b> .....    | 20    |
| Specifications .....                       | 9     | Fresh Food Storage .....           | 20    |
| <b>INSTALLATION INSTRUCTIONS</b> .....     | 10-15 | Freezer Storage .....              | 20    |
| Unpack the Refrigerator .....              | 10    | <b>REFRIGERATOR CARE</b> .....     | 21-22 |
| Location Requirement .....                 | 11    | Cleaning .....                     | 21    |
| Electrical Requirements .....              | 11    | To Clean Your Refrigerator .....   | 21    |
| Parts And Features .....                   | 12    | Vacation And Moving Care .....     | 22    |
| Reverse Doors .....                        | 13-14 | Moving .....                       | 22    |
| Adjusting The Doors.....                   | 15    | <b>TROUBLESHOOTING GUIDE</b> ..... | 23-24 |
| Door Aligning .....                        | 15    |                                    |       |
| <b>REFRIGERATOR USE</b> .....              | 16    |                                    |       |
| <b>FREEZER FEATURES</b> .....              | 17    |                                    |       |
| <b>REFRIGERATOR FEATURES</b> .....         | 17-18 |                                    |       |
| Refrigerator Shelves .....                 | 17    |                                    |       |
| Crisper .....                              | 18    |                                    |       |

## PRODUCT RECORD

In the space below, record the date of purchase, model and serial number of your product. You will find the model and serial number printed on an identification label located on the interior liner of the refrigerator compartment.

Model No. \_\_\_\_\_

Date of Purchase \_\_\_\_\_

Serial No. \_\_\_\_\_

Save these instructions and attach your sales receipt for future reference.

# WARRANTY

## 1 Year Limited Warranty

FOR ONE YEAR from the date of sale this product is warranted against defects in material or workman-ship.

WITH PROOF OF SALE a defective product will be repaired or replaced free of charge.

Direct all claims for warranty service to Kenmore Customer Assistance, call 1-800-265-8456 or email [KenmoreCustomerCare@koolatron.com](mailto:KenmoreCustomerCare@koolatron.com)

This warranty covers manufacturer's defects including electrical and mechanical defects provided the appliance is correctly assembled, operated and maintained according to the supplied instructions. It does not cover damage caused by accident, misuse or abuse including overheating, unauthorized repairs or alterations, or use with a voltage converter or aftermarket accessories, and it does not apply to scratches, stains, discoloration or other surface damage that does not impair the product function. This warranty is void if the appliance is ever used for purposes other than private household use.

Koolatron Corporation  
4320 Federal Drive, Batavia, NY 14020 U.S.A.  
139 Copernicus Blvd., Brantford, ON N3P1N4 Canada

Kenmore and the Kenmore logo are registered trademarks to Transform SR Brands LLC and are used under license by Koolatron Corporation

H1S445  
06/2026-v6

# IMPORTANT SAFETY INSTRUCTIONS

## BASIC SAFETY PRECAUTIONS

This guide contains many important safety messages. Always **read and obey** all safety messages.



This is the safety alert symbol. It alerts you to safety messages that inform you of hazards that can kill or hurt you or others, or cause damage to the product.

All safety messages will be preceded by the safety alert symbol and the hazard signal word **DANGER**, **WARNING** or **CAUTION**. These words mean:

**! DANGER**

You **will** be killed or seriously injured if you do not follow instructions.

**! WARNING**

You **can** be killed or seriously injured if you do not follow instructions.

**! CAUTION**

Indicates an imminently hazardous situation which, if not avoided, **may** result in minor or moderate injury, or product damage.

All safety messages will identify the hazard, tell you how to reduce the chance of injury, and tell you what can happen if the instructions are not followed.

## **! WARNING**

**To reduce the risk of fire, electric shock, or personal injury when using your product, basic safety precautions should be followed, including the following.**

**Read all instructions before using this appliance.**

- NEVER unplug your refrigerator by pulling on the power cord. Always grip the plug firmly and pull it straight out from the outlet.
- If the supply cord is damaged, it must be replaced by the manufacturer or its service agent or a similarly qualified person in order to avoid a hazard. Do not use a cord that shows cracks or abrasion damage along its length or at either the plug or connector end.
- Do not modify or extend the power cord length. It could cause electric shock or fire.
- When moving your refrigerator away from the wall, be careful not to roll over or damage the power cord.
- DO NOT store or use gasoline or other flammable vapors and liquids in the vicinity of this or any other appliance.
- This appliance is not intended for use by persons (including children) with reduced physical, sensory or mental capabilities, or lack of experience and knowledge, unless they have been given supervision or instruction concerning use of the appliance by a person responsible for their safety.

- DO NOT allow children to climb, stand, or hang on the refrigerator doors or shelves in the refrigerator. They could damage the refrigerator and seriously injure themselves.
- Keep fingers out of pinch point areas; clearances between the doors and cabinets are necessarily small. Be careful closing doors when children are in the area.
- Unplug your refrigerator before cleaning or making any repairs.

**NOTE:** It is strongly recommended that any service be performed by a qualified technician.

- Keep ventilation openings, in the appliance enclosure or in the built-in structure, clear of obstruction.
- Do not use mechanical devices or other means to accelerate the defrosting process, other than those recommended by the manufacturer
- Do not damage the refrigerant circuit
- Do not use electrical appliances inside the food storage compartments of the appliance unless they are of the type recommended by the manufacturer
- Connect to potable water supply only.

## **IMPORTANT SAFETY INSTRUCTIONS**

This appliance is not intended for use by persons (including children) with reduced physical, sensory or mental capabilities, or lack of experience and knowledge, unless they have been given supervision or instruction concerning use of the appliance by a person responsible for their safety.

If the supply cord is damaged, it must be replaced by the manufacturer, its service agent or similarly qualified persons in order to avoid a hazard.

## **SAVE THESE INSTRUCTIONS**

## IMPORTANT SAFETY INSTRUCTIONS

|  |  |
|--|--|
| DANGER risk of fire or explosion. Flammable refrigerant used. Do not use mechanical devices to defrost refrigerator. Do not puncture refrigerant   | DANGER risque d'incendie ou d'explosion. Réfrigérant inflammable utilisé. Ne pas utiliser de dispositifs mécaniques pour dégivrer votre réfrigérateur. Ne percez pas le réfrigérant.   |
| DANGER risk of fire or explosion. Flammable refrigerant used. To be repaired only by trained service personnel. Do not puncture refrigerant tubing.  | DANGER risque d'incendie ou d'explosion. Réfrigérant inflammable utilisé. À être réparé seulement par du personnel d'entretien qualifié. Ne percez pas le tuyau de réfrigérant.  |
| CAUTION risk of fire or explosion. Flammable refrigerant used. Consult repair manual/owner's guide before attempting to service this product. AN safety precautions must be followed.        | MISE EN GARDE risque d'incendie ou d'explosion. Réfrigérant inflammable utilisé. Consultez le manuel de réparation/le guide du propriétaire avant d'essayer de réparer ce produit. Les mesures de sécurité AN doivent être suivies.        |
| CAUTION risk of fire or explosion. Dispose of properly in accordance with federal or local regulations. Flammable refrigerant used.  | MISE EN GARDE risque d'incendie ou d'explosion. Mettre au rebut conformément aux réglementations fédérales et locales. Réfrigérant inflammable utilisé.  |
| CAUTION risk of fire or explosion due to puncture of refrigerant tubing; follow handling instructions carefully. Flammable refrigerant used.   | MISE EN GARDE risque d'incendie ou d'explosion due à la perforation des tuyaux de réfrigération ; suivre attentivement les instructions de manipulation. Réfrigérant inflammable utilisé.  |
| WARNING keep ventilation openings, in the appliance enclosure or in the built-in structure, clear of obstruction.  | AVERTISSEMENT gardez les trappes de ventilation du cadre de l'appareil ou dans la structure incorporée, à l'abri de toute obstruction.   |
| WARNING do not use mechanical devices or other means to accelerate the defrosting process, other than those recommended by the manufacturer.   | AVERTISSEMENT ne pas utiliser de dispositifs mécaniques ou d'autres moyens pour accélérer le processus de dégivrage, autres que ceux recommandés par le fabricant.   |
| WARNING do not damage the refrigerant circuit.   | AVERTISSEMENT ne pas endommager le circuit de réfrigération.   |
| WARNING do not use electrical appliances inside the food storage compartments of the appliance, unless they are of the type recommended by the manufacturer.                                 | AVERTISSEMENT ne pas utiliser d'appareils électriques à l'intérieur des compartiments de conservation des aliments de l'appareil, sauf s'ils sont du type recommandé par le fabricant.   |
| WARNING connect to potable water supply only.  | AVERTISSEMENT branchez à l'eau potable seulement.  |
| DANGER risk of child entrapment. Before you throw away your old refrigerator or freezer :<br>Take off the doors.<br>Leave the shelves in place so that children may not easily climb inside. | DANGER de prise au piège pour l'enfant Avant de mettre au rebut votre ancien réfrigérateur ou congélateur :<br>Enlevez les portes.<br>Laissez les tablettes en place pour que les enfants ne puissent pas entrer à l'intérieur facilement. |

## REFRIGERATOR SAFETY

### Your safety and the safety of others are very important.

We have provided many important safety messages in this manual and on your appliance. Always read and obey all safety messages.



This is the safety alert symbol.

This symbol alerts you to potential hazards that can kill or hurt you and others.

All safety messages will follow the safety alert symbol and either the word “DANGER” or “WARNING.” These words mean:

**! DANGER**

You can be killed or seriously injured if you don't immediately follow instructions.

**! WARNING**

You can be killed or seriously injured if you don't follow instructions.

All safety messages will tell you what the potential hazard is, tell you how to reduce the chance of injury, and tell you what can happen if the instructions are not followed.

## IMPORTANT SAFETY INSTRUCTIONS

**WARNING:** To reduce the risk of fire, electric shock, or injury to persons when using the refrigerator, follow basic precautions, including the following:

- Plug into a grounded 3 prong outlet.
- Do not remove ground prong.
- Do not modify plug on power cord. If plug does not fit electrical outlet, have proper outlet installed by a qualified electrician.
- Do not use a two-prong adapter, extension cord or power strip.
- Do not service or replace any part of refrigerator unless specifically recommended in Use & Care Guide or published user-repair instructions. Do not attempt service if instructions are not understood or if they are beyond personal skill level.
- Always disconnect refrigerator from electrical supply before attempting any service.
- Disconnect power cord by grasping the plug, not the cord.
- Install refrigerator according to Installation Instructions. All connections for water, electrical power and grounding must comply with local codes and be made by licensed personnel when required.
- Keep your refrigerator in good condition. Bumping or dropping refrigerator can damage refrigerator or cause refrigerator to malfunction or leak. If damage occurs, have refrigerator checked by qualified service technician.
- Replace worn power cords and/or loose plugs.
- Always read and follow manufacturer's storage and ideal environment instructions for items being stored in refrigerator.
- Your refrigerator should not be operated in the presence of explosive fumes.
- Remove doors from your old refrigerator.
- Children should not climb, hang or stand on any part of the refrigerator.
- Clean up spills or water leakage associated with water installation.
- Use nonflammable cleaner.
- Keep flammable materials and vapors, such as gasoline, away from refrigerator.
- Use two or more people to move and install refrigerator.
- Disconnect power before installing icemaker (on icemaker kit ready models only).

## SAVE THESE INSTRUCTIONS

## SPECIFICATIONS

| MODELS                 |                     | KKTMR30X18.1-SSL / KKTMR30X18.1-W / KKTMR30X18.1-B |
|------------------------|---------------------|--|
| EXTERNAL DIMENSIONS    | WIDTH               | 29.7 in  |
|                        | DEPTH               | 30.1 in  |
|                        | HIGHT               | 66.1 in  |
| NET WEIGHT             |                     | 154.3 Lbs  |
| SYSTEM CHARACTERISTICS | FREEZER CAPACITY    | 4.8 cu.ft.   |
|                        | FRESH FOOD CAPACITY | 13.3 cu.ft.  |
|                        | TOTAL CAPACITY      | 18.1 cu.ft.  |
|                        | COOLING SYSTEM      | FORCED CONVECTION                                  |
|                        | DEFROST SYSTEM      | BY RESISTENCE, TYPE SHEATH                         |
|                        |                     | AUTOMATIC  |
|                        | REFRIGERANT         | R600a  |
| SUPPLY VOLTAGE         | 115V/60Hz           |  |

## **! DANGER**

### **Child Entrapment and Suffocation Hazard**

Remove doors from your old refrigerator.  
Failure to do so can result severe injury or death.

Junked or abandoned refrigerators are still dangerous – even if they will sit for “just a few days.” If you are getting rid of your old refrigerator, please follow these instructions to help prevent accidents.

CALIFORNIA PROPOSITION 65

### **! WARNING**

The use of this appliance can expose you to chemicals known to the state of California to cause cancer, birth defects, or other reproductive harm. For more information go to [www.P65Warnings.ca.gov](http://www.P65Warnings.ca.gov)

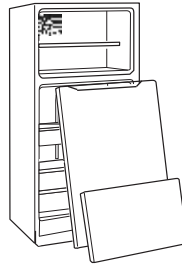

### **BEFORE YOU THROW AWAY YOUR OLD REFRIGERATOR OR FREEZER:**

- Take off the doors.
- Leave the shelves in place so that children may not easily climb inside.

### **Important information to know about disposal of refrigerants:**

Dispose of refrigerator in accordance with Federal and Local regulations. Refrigerants must be evacuated by a licensed, EPA certified refrigerant technician in accordance with established procedures.

## **INSTALLATION INSTRUCTIONS**

## **! WARNING**

### **Excessive Weight Hazard**

Use two or more people to move and install refrigerator. Failure to do so can result in back or other injury.

### **Remove the Packaging**

- Remove tape and glue residue from surfaces before turning on the refrigerator. Rub a small amount of liquid dish soap over the adhesive with your fingers. Wipe with warm water and dry.

**NOTE:** Do not use sharp instruments, rubbing alcohol, flammable fluids, or abrasive cleaners to remove tape or glue. These products can damage the surface of your refrigerator. For more information, see “Refrigerator Safety.”

- Dispose of/recycle all packaging materials.

**IMPORTANT:** Do not remove the white foam air return insert that is located behind the control panel on the ceiling of the refrigerator (on some models). The insert is part of the refrigerator and not part of the packing material. If the insert is removed, ice may migrate down from the freezer and cause icicles to form.

### **When Moving Your Refrigerator:**

Your refrigerator is heavy. When moving the refrigerator for cleaning or service, be sure to cover the floor with cardboard or hardboard to avoid floor damage. Always pull the refrigerator straight out when moving it. Do not wiggle or “walk” the refrigerator when trying to move it, as floor damage could occur.

### **Clean Before Using**

- After you remove all of the package materials, clean the inside of your refrigerator before using it. See the cleaning instructions in “Refrigerator Care.”

### **Important information to know about glass shelves and covers:**

Do not clean glass shelves or covers with warm water when they are cold. Shelves and covers may break if exposed to sudden temperature changes or impact, such as bumping. Tempered glass is designed to shatter into many small, pebble-size pieces. This is normal. Glass shelves and covers are heavy. Use both hands when removing them to avoid dropping.

# INSTALLATION INSTRUCTIONS

## Location requirement

### ⚠ WARNING



#### Explosion Hazard

Keep flammable materials and vapors, such as gasoline, away from refrigerator.  
Failure to do so can result in death, explosion, or fire.

**IMPORTANT:** This refrigerator is designed for indoor household use only.

To ensure proper ventilation for your refrigerator, allow for 3.2" (8.13 cm) of space on each side and at the top. Allow for 3.2" (8.13 cm) of space behind the refrigerator. If your refrigerator has an icemaker, allow extra space at the back for the water line connection. When installing your refrigerator next to a fixed wall, leave a 3.2" (8.13 cm) minimum space on the hinge side (some models require more) to allow the door to swing open.

We do not recommend the installation of the refrigerator where the temperature will drop below 45°F (7°C) or rise above 110°F (43°C). The compressor will not be able to maintain proper temperatures inside the refrigerator. For installations where the temperatures will drop below 50° set the freezer temperature control to the "Coldest" setting this will improve the operations of the refrigerator under these conditions.

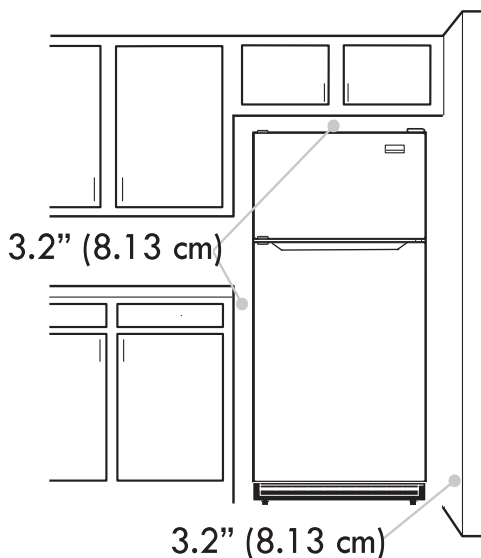

## Electrical Requirements

### ⚠ WARNING



#### Electrical Shock Hazard

Plug into a grounded 3 prong outlet.  
Do not remove ground prong. Do not use an adapter.  
Do not use an extension cord.  
Failure to follow these instructions can result in death, fire, or electrical shock.

**NOTE:** This refrigerator is intended for use in a location where the temperature ranges from a minimum of 45°F (7°C) to a maximum of 110°F (43°C). The preferred room temperature range for optimum performance, which reduces electricity usage and provides superior cooling, is between 60°F (15°C) and 90°F (32°C). It is recommended that you do not install the refrigerator near a heat source, such as an oven or radiator.

Use caution when installing the unit on vinyl or hardwood floors so as not to mark or otherwise damage the flooring. A piece of plywood, a rug or other material should be used to protect the floor while positioning the unit.

Before you move your refrigerator into its final location, it is important to make sure you have the proper electrical connection.

#### Recommended Grounding Method

A 115 volt, 60 Hz, AC only, 15- or 20-amp fused, grounded electrical supply is required. It is recommended that a separate circuit serving only your refrigerator be provided. Use an outlet that cannot be turned off by a switch. Do not use an extension cord.

**NOTE:** Before performing any type of installation or cleaning, disconnect the refrigerator from the electrical source. When you are finished, reconnect the refrigerator to the electrical source.

## PARTS AND FEATURES

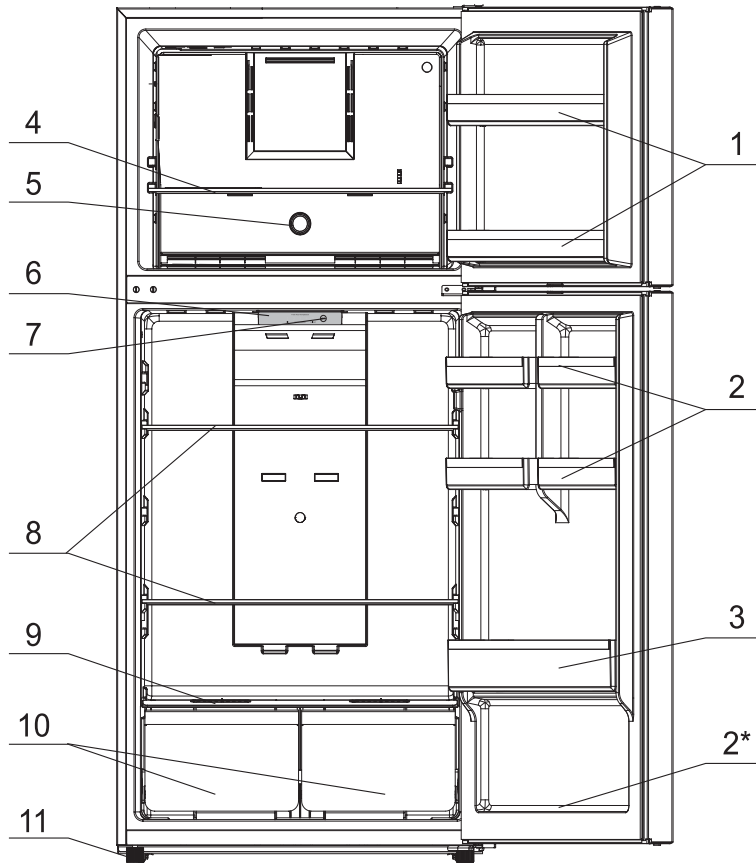

|          |   |           |  |
|----------|---|-----------|--|
| <b>1</b> | <b>Freezer Door Bins (2)</b>            | <b>7</b>  | <b>Refrigerator Temperature Control Knob</b> |
| <b>2</b> | <b>Refrigerator Door Bins (4)</b>       | <b>8</b>  | <b>Refrigerator Shelves (2)</b>              |
| <b>3</b> | <b>Refrigerator Door Gallon Bin</b>     | <b>9</b>  | <b>Glass Crisper Cover</b>                   |
| <b>4</b> | <b>Freezer Shelf (1)</b>                | <b>10</b> | <b>Crisper Bin (2)</b>                       |
| <b>5</b> | <b>Freezer Temperature Control Knob</b> | <b>11</b> | <b>Leveling Leg</b>                          |
| <b>6</b> | <b>LED Interior Light</b>               |           |  |

\*This instruction manual refers to several models. Features may vary according to model.

# INSTALLATION INSTRUCTIONS

## Reverse Doors (optional)

**IMPORTANT:** If you want to reverse your doors so that they open in the opposite direction, follow these steps.

**Tools Required:** 5/16 " end wrench, Phillips screwdriver, Putty knife, 5/16 " socket and ratchet, Middle hinge.

**Note:** An additional middle hinge is included inside the refrigerator. Use this middle hinge for left door swing configuration. Do not use the original middle hinge.

### Unplug the refrigerator

1. Tape the freezer door shut with masking tape. Pry off hinge cap with a flat blade screwdriver and set aside.
2. With a 5/16 " socket and ratchet, remove screws from the top hinge and set aside.
3. Remove the tape and carefully lift and remove freezer door (including the top hinge) off the center hinge.
4. With a Phillips screwdriver, remove freezer door stop from the underside of the freezer door and secure it on the opposite side.
5. With a putty knife, carefully pry out the hinge hole plug from the top of the freezer door and install it on the other side.
6. Remove the screw hole plug from top of cabinet and install it on the opposite side.

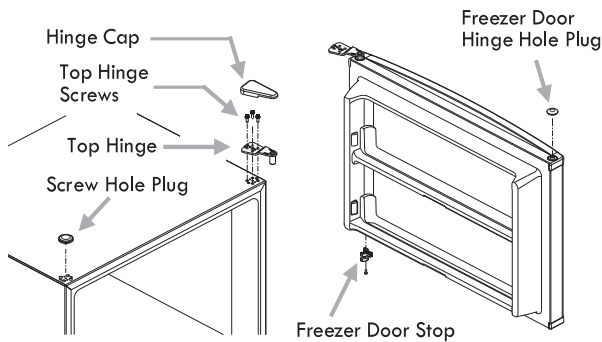

#### NOTE:

- Do not misplace the top hinge screws.
- Set the door on a non-scratching surface with the inside up.
- Do not let door to drop to the floor when setting it down, or the door stop could be damaged.

7. Tape the refrigerator door shut with masking tape. With a 5/16 " socket and ratchet, remove the middle hinge screws and middle hinge from the top of refrigerator door. Using a flat blade screwdriver, unscrew the dome cap and the middle hinge hole cover.

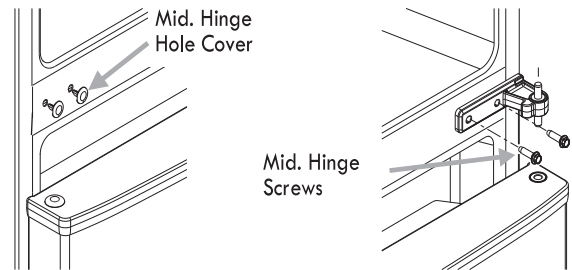

**NOTE:** Do not misplace the middle hinge screws.

8. Remove the tape and carefully lift and remove refrigerator door.
9. The size of this refrigerator is large and requires two people to cooperate when replacing the bottom hinge. One person helped stabilize the refrigerator, while the other one used a tool to replace the bottom hinge.
10. With a 5/16 " socket and ratchet, remove the bottom hinge plate from lower corner of refrigerator and secure it on the opposite side. When the refrigerator is still unstable on the ground, you can manually twist the adjustment foot to make the refrigerator reach a stable state.

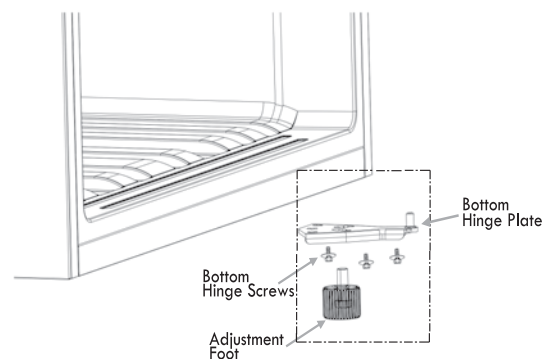

#### NOTE:

- Do not misplace the bottom hinge screws, cabinet screws.
- Set the door on a non-scratching surface with the inside up.
- Do not let door to drop to the floor when setting it down, or the door stop could be damaged.

# INSTALLATION INSTRUCTIONS

## Reverse Doors (optional) (continued)

11. Remove the refrigerator door stop from the underside of refrigerator door and secure it on the opposite side with a Phillips screwdriver.
12. With a screwdriver, pry out the plugs from the top of refrigerator door and replace them on the opposite side and swap the refrigerator door stop to other side.

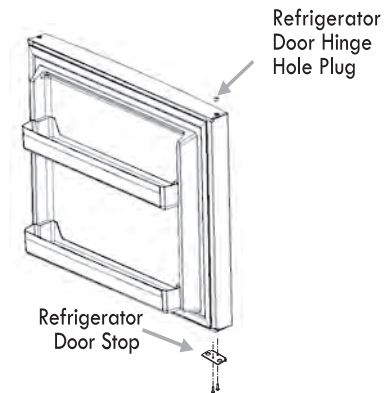

13. Remove the gaskets from freezer and refrigerator door. And then rotate them 180 degrees. Reassemble them by pushing from bottom to top.

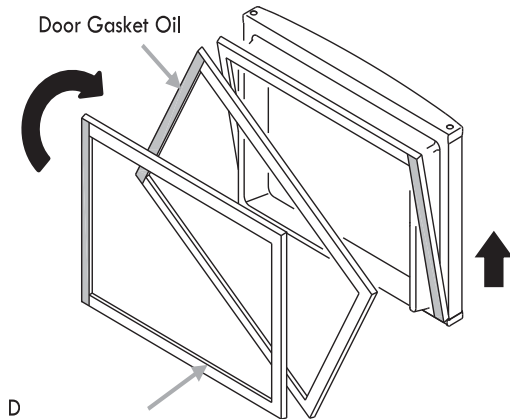

**NOTE:** The oil on the gasket is normal. There is no need to clean the oil. It helps to prevent deformation of the hinge side of gasket. If more oil is needed, use Vaseline.

14. Carefully place refrigerator door onto the hinge plate in lower corner.
15. Use the additional middle hinge that is included inside the refrigerator for the left door swing configuration. Attach the middle hinge with the screws removed from the opposite side and secure them using 5/16" wrench.

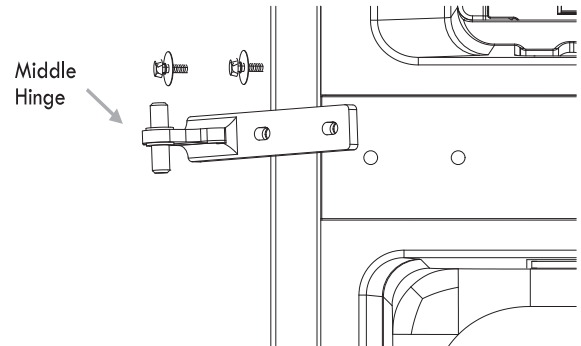

**NOTE:** The bottom refrigerator door hinge may need to be adjusted if the door gasket is not sealing or if the gasket does not move freely with door operation. To adjust, carefully lean the refrigerator back as before (refer to instruction #9) and loosen but do not remove the bottom hinge screws. Adjust the hinge position as needed and once again secure the bottom hinge plate screws and carefully lower the refrigerator. Test the door opening/ closing and gasket seal.

16. Use foam door spacer to set the correct gap between the freezer and refrigerator door. Place spacer between the doors when tightening the freezer door top hinge.

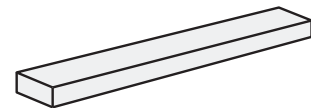

**NOTE:** You may need to use the spacer again to set gap. Ensure the washer is in place on top of the hinge shaft.

17. Slide top hinge into place on freezer door and secure screws with 5/16 " wrench. Confirm that all screws have been tightened securely.
18. Snap hinge cap securely in place.

# INSTALLATION INSTRUCTIONS

## Adjusting the Doors

### Leveling

Your refrigerator has two front adjustable legs - near each front corner of the refrigerator, next to the rollers. If your refrigerator seems unsteady or you want the doors to close easier, adjust the refrigerator's tilt using the following instructions:

1. Turn the two front leveling legs clockwise to raise the front of the refrigerator and counterclockwise to lower.

**NOTE:** Having someone push against the top of the refrigerator takes some weight off the leveling legs which makes it easier to adjust.

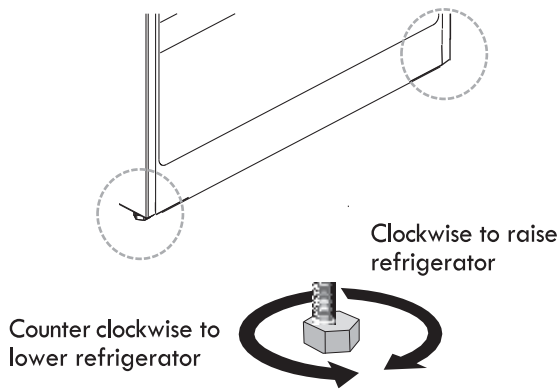

2. Open both doors again to make sure they close as easily as you like and that they stay closed. If not, tilt the refrigerator slightly more to the rear by turning both leveling legs clockwise.

### NOTE:

- Before moving the refrigerator away from the wall be sure to turn the leveling legs counterclockwise so that the weight of the refrigerator is fully transferred to the front rollers.
- If the floor is not level and it is necessary to raise the rear of the refrigerator we suggest rolling the rear rollers onto a piece of plywood or other shim material.

## Door Aligning

If the space between your doors looks uneven, you can adjust it using the following instructions:

**NOTE:** Use foam door spacer to set the correct gap between the freezer and refrigerator door. Place spacer between the doors when tightening the freezer door top hinge.

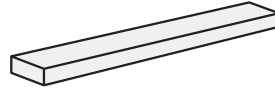

### If the freezer door is too high:

1. Remove the hinge cap on top of the freezer door and loosen the screws with a 5/16" socket and ratchet.
2. Place the door spacer between the doors to establish the correct gap and tighten the hinge screws.
3. Fully tighten all screws and replace the hinge cap.

### If both doors are too high:

1. Remove the hinge cap on top of the freezer door and loosen the screws with a 5/16" socket and ratchet.
2. Loosen the two middle hinge screws with a 5/16" socket and ratchet.
3. Slide the middle hinge to the left to lower the doors.
4. Fully tighten all screws and replace hinge cap.

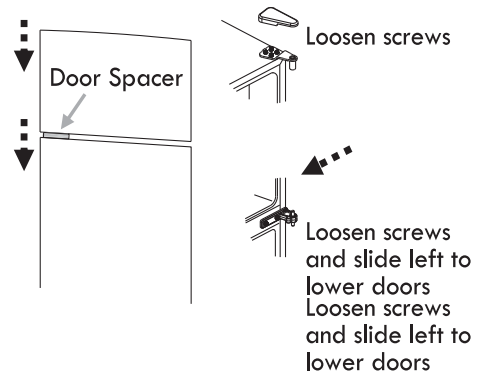

### If both doors are too low:

1. Remove the hinge cap on top of the freezer door and loosen the screws with a 5/16" socket and ratchet.
2. Loosen the two middle hinge screws with a 5/16" socket and ratchet.
3. Slide the middle hinge to the right to raise the doors.
4. Fully tighten all screws and replace hinge cap.

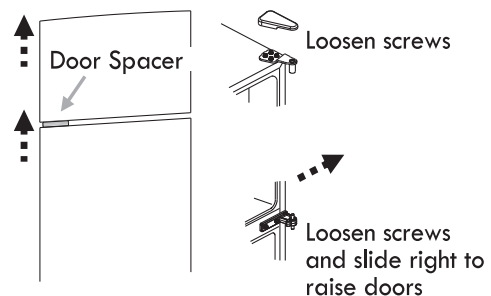

# REFRIGERATOR USE

## OPERATING YOUR APPLIANCE

### Refrigerator Temperature Control



1. Your refrigerator has one control for regulating the temperature. As well as a control knob in the freezer to balance the cold air distribution between the two compartments.
2. The temperature control in the refrigerator compartment will control the actual cooling cycle where as the control knob in the freezer compartment will adjust the distribution of the cold air between the freezer and the refrigerator compartments.
3. The first time you plug in and turn the unit on, adjust the temperature control knob to “Coldest” in the freezer compartment and “5 - Coldest” in the refrigerator compartment and run for at least 4 hours before placing foods inside. This will ensure the freezer cabinet is thoroughly chilled and the refrigerator compartment will be stabilized before food is placed. Then return selector to “Recommended” position in the freezer compartment and “3” in the refrigerator compartment.
4. Adjust the temperature control to the setting that best suits your needs. The setting of “3” in the refrigerator compartment and “Recommended” in the freezer compartment will distribute the cold air equally between both compartments which should be appropriate for home or office refrigerator use.

### Freezer Temperature Control

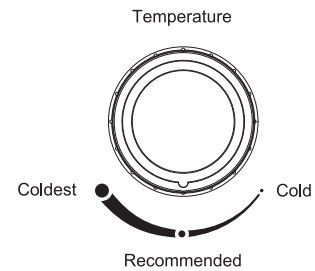

1. If you at any time want to distribute a larger amount of cold air to the freezer for example if a large amount of food has been added to the freezer , simply move the controller to the “Coldest” position until the desired temperature has been attained then return the controller to the “Recommended” position.
2. If you at any time want to distribute a larger amount of cold air to the refrigerator section , for example to quickly cool down if a large amount of fresh food has been added , simply move the controller in the freezer to the “Cold” position until the desired temperature has been attained and then return the controller to the “Recommended” position.

**NOTE:**If the unit is unplugged,has lost power,or is turned off,you must wait 3 to 5 minutes before restarting the unit. If you attempt to restart before this time delay, the refrigerator-freezer will not start.

**NOTE:**We do not recommend the installation of the refrigerator where the temperature will drop below 45°F(7°C) or rise above 110°F(43°C). The compressor will not be able to maintain proper temperatures inside the refrigerator.

For installations where the temperatures will drop below 50°set the freezer temperature control to the “Coldest” setting this will improve the operations of the refrigerator under these conditions.

## REFRIGERATOR FEATURES

Your model may have some or all of these features.

### Information about glass shelves and covers:

## Refrigerator Shelves

The shelves in your refrigerator are adjustable to match your individual storage needs.

Storing similar food items together in your refrigerator and adjusting the shelves to fit different heights of items will make finding the exact item you want easier. It will also reduce the amount of time the refrigerator door is open, and save energy.

### IMPORTANT:

- Do not clean glass shelves or covers with warm water when they are cold. Shelves and covers may break if exposed to sudden temperature changes or impact, such as bumping.
- Tempered glass is designed to shatter into many small, pebble-size pieces. This is normal.
- Glass shelves and covers are heavy. Use both hands when removing them to avoid dropping.

### CAUTION: To avoid personal injury or property damage.

- Never attempt to adjust a shelf when it is loaded with food.
- Confirm that shelf is secure prior to loading items onto it.

## FREEZER FEATURES

### ⚠ CAUTION:

To avoid personal injury or property damage.

- Never attempt to adjust a shelf when it is loaded with food.
- Confirm that shelf is secure prior to loading items onto it.

### To remove and replace a glass shelf:

1. Remove the food from the shelf.
2. Lift up after side of shelf slightly and slide it front as far as it will go into the center of the left shelf support holes. The right side of the shelf will release from the support holes on the right. Raise up right side of shelf to remove from freezer compartment.

# REFRIGERATOR FEATURES

## Crisper

### Crisper Drawers

The Crispers provide a storage area for fruit and vegetables.

Excess water that may accumulate in the bottom of the drawers or under the drawers should be wiped dry.

#### To remove and replace the crisper drawer:

1. Slide the crisper drawer straight out to the stop. Lift the front and slide the drawer out the rest of the way.
2. Replace the drawer by sliding the drawer in fully past the stop.

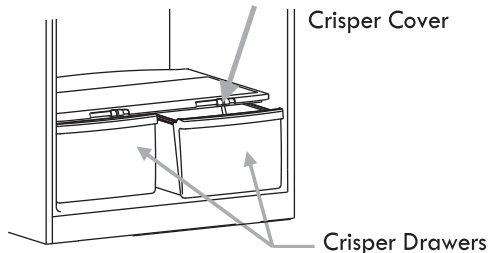

**NOTE:** If the refrigerator door prevents you from taking out a crisper drawer, first try removing any obstructing door bins. If bin removal still does not provide enough clearance, the refrigerator will need to be rolled forward from its installation position until the door can be opened enough to glide the drawers out.

### Crisper Cover

#### To remove and replace the crisper cover:

1. Remove the food from the cover and then the crisper drawers.
2. Support the cover from underneath to lift it up and then out of the cabinet.
3. To replace the cover, tilt front of cover frame slightly up and carefully insert the back of the cover frame into the cabinet.

With the cover front tilted slightly upward, carefully insert the cover top back into the cabinet.

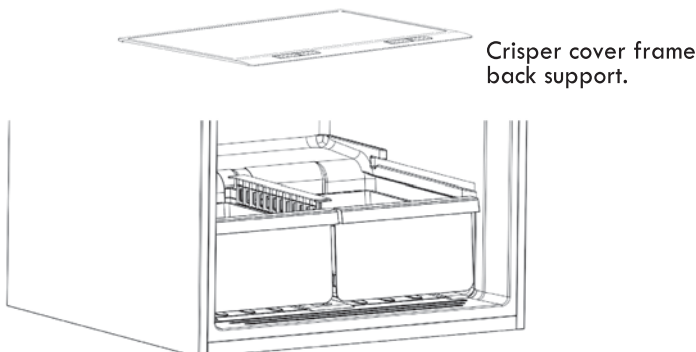

### Crisper Humidity Control

You can control the amount of humidity in the moisture-sealed crisper. For most fruits, slide the control (select models) to "right" to provide and vegetables with skins lower humidity conditions in the drawer. For leafy vegetables, slide the control to "left" to provide higher humidity conditions in the drawer. For best results, keep the crisper drawers tightly closed.



- Fruit: Wash, let dry and store in refrigerator in plastic bag or crisper. Do not wash or hull berries until they are ready to use. Sort and keep berries in original container in crisper, or store in a loosely closed paper bag on a refrigerator shelf.
- Vegetables with skins: Place in plastic bag or plastic container and store in crisper.
- Leafy vegetables: Wash in cold water, drain and trim or tear off bruised and discolored areas. Place in plastic bag or plastic container and store in crisper.

## DOOR FEATURES

### Door Bins

The door bins are removable for easy cleaning and adjustment.

1. To remove the bin, simply lift the bin up and pull straight out.
2. To replace the bin, slide it in above the support and push down until it snaps into place.

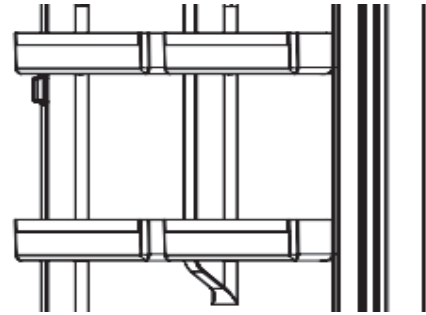

### Gallon Door Storage Bin

The gallon door storage bin can be used for items of medium to large size.

**To remove for cleaning:**

1. To remove the bin, simply lift the bin up and pull straight out.
2. To replace the bin, slide it in above the support and push down until it snaps into place.

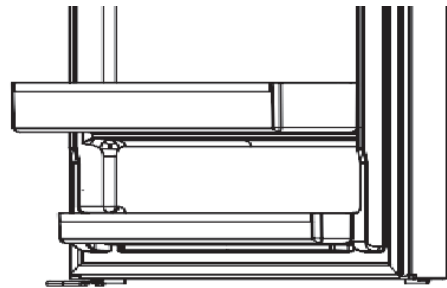

# FOOD STORAGE GUIDE

## Fresh Food Storage

- The fresh food compartment of a refrigerator should be kept between 34°F (1°C) and 40°F (4°C) with an optimum temperature of 37°F (3°C). To check the temperature, place an appliance thermometer in a glass of water and place in the center of the refrigerator. Check after 24 hours. If the temperature is above 40°F (4°C) adjust the control as explained on “Temperature Control” page.
- Avoid overcrowding the refrigerator shelves. This reduces the circulation of air around the food and results in uneven cooling.
- Storage in the crisper drawers traps humidity to help preserve the fruit and vegetable quality for longer time periods
- Sort fruits and vegetables before storage and use bruised or soft items first. Discard those showing signs of decay.
- Always wrap odorous foods such as onions and cabbage so the odor does not transfer to other foods.
- While vegetables need a certain amount of humidity to remain fresh, too much moisture can shorten storage times (especially leafy items). Drain vegetables well before storing.
- Raw meat and poultry should be wrapped securely so leakage and contamination of other foods or surfaces does not occur.
- Occasionally mold will develop on the surface of hard cheeses (Swiss, Cheddar, Parmesan). Cut off at least an inch around and below the moldy area. Keep your knife or instrument out of the mold itself. Do not try to save individual cheese slices, soft cheese, cottage cheese, cream, sour cream or yogurt when mold appears.
- Most dairy foods such as milk, yogurt, sour cream and cottage cheese have freshness dates on their cartons for appropriate length of storage. Store these foods in the original carton and refrigerate immediately after purchasing and after each use.

## Freezer Storage

- The freezer compartment of a refrigerator should be kept at approximately 0°F (-18°C). To check the temperature, place an appliance thermometer between the frozen packages and check after 24 hours. If the temperature is above 0°F (-18°C), adjust the control as explained on “Temperature Control” page.
- Storage times will vary according to the quality and type of food, the type of packaging or wrap used (should be airtight and moisture-proof), and the storage temperature.
- Seal the package or container securely to avoid taste and odor transfer throughout the product. Ice crystals inside a sealed package are normal. This simply means that moisture in the food and air inside the package have condensed, creating ice crystals.
- A freezer operates more efficiently when it is at least 2/3 full. Leave a space between the packages so cold air can circulate freely, allowing food to freeze as quickly as possible.
- To minimize dehydration and quality deterioration use aluminum foil, freezer wrap, freezer bags or airtight containers. Force as much air out of the packages as possible and be sure they are tightly sealed. Trapped air can cause the food to dry out, change color and develop an off-flavor (freezer burn).
- Do not refreeze meat that has completely thawed.
- Avoid adding too much warm food to the freezer at one time. This overloads the freezer, slows the rate of freezing and can raise the temperature of frozen foods.
- Avoid storing hard-to-freeze foods such as ice cream and orange juice on the freezer door shelves. These foods are best stored in the freezer interior where the temperature varies less with door openings.

# REFRIGERATOR CARE

## Cleaning

### **WARNING**



#### **Explosion Hazard**

Use nonflammable cleaner.  
Failure to do so can result in death, explosion, or fire.

Both the refrigerator and freezer sections defrost automatically. However, clean both sections about once a month to avoid buildup of odors. Wipe up spills immediately.

**IMPORTANT:** Because air circulates between both sections, any odors formed in one section will transfer to the other. You must thoroughly clean both sections to eliminate odors. To avoid odor transfer and drying out of food, wrap or cover foods tightly.

## To Clean Your Refrigerator

**WARNING:** To avoid electrical shock which can cause severe personal injury or death, disconnect the power cord before moving or cleaning the refrigerator.

**NOTE:** Do not use abrasive or harsh cleaners such as window sprays, scouring cleansers, flammable fluids, cleaning waxes, concentrated detergents, bleaches or cleansers containing petroleum products on exterior surfaces (doors and cabinet), plastic parts, interior and door liners or gaskets. Do not use paper towels, scouring pads, or other harsh cleaning tools.

1. Unplug refrigerator or disconnect power.
2. Hand wash, rinse, and dry removable parts and interior surfaces thoroughly. Use a clean sponge or soft cloth and a mild detergent in warm water.
3. Clean the exterior surfaces.

**Painted metal or Active Finish™:** Wash painted metal exteriors with a clean, soft cloth or sponge and a mild detergent in warm water. Rinse surfaces with clean, warm water and dry immediately to avoid water spots.

**Stainless Steel:** Wash stainless steel surfaces with a clean, soft cloth or sponge and a mild detergent in warm water. Rinse surfaces with clean, warm water and dry immediately to avoid water spots.

**NOTE:** When cleaning stainless steel, always wipe in the direction of the grain to avoid cross-grain scratching.

4. Plug in refrigerator or reconnect power.

**NOTE:** The condenser does not require cleaning, however the conditions may warrant inspection and occasional dust and pet hair removal from the machine compartment by a service professional to ensure no damage to the product.

# REFRIGERATOR CARE

## Vacation and Moving Care

### Vacations

#### If You Choose to Leave the Refrigerator On While You're Away:

Use up any perishables and freeze other items.

#### If You Choose to Turn Off the Refrigerator Before You Leave:

1. Remove all food from the refrigerator.
2. Disconnect the refrigerator from the electrical outlet.
3. Clean refrigerator, wipe it, and dry well.
4. Tape rubber or wood blocks to the tops of both doors to prop them open far enough for air to get in. This stops odor and mold from building up.

### Moving

1. Remove all food from the refrigerator and pack all frozen food in dry ice.
2. Unplug refrigerator.
3. Clean, wipe, and dry thoroughly.
4. Take out all removable parts, wrap them well, and tape them together so they don't shift and rattle during the move.
5. Depending on the model, raise the front of the refrigerator so it rolls more easily OR raise the leveling legs so they don't scrape the floor.
6. Tape the doors closed and tape the power cord to the back of the refrigerator.

When you get to your new home, put everything back and refer to the "Installation Instructions" section for preparation instructions.

# TROUBLESHOOTING GUIDE

First try the solutions suggested here or visit our website to possibly avoid the cost of a service call.

## ⚠ WARNING



### Electrical Shock Hazard

Plug into a grounded 3 prong outlet.  
 Do not remove ground prong. Do not use an adapter.  
 Do not use an extension cord.  
 Failure to follow these instructions can result in death, fire, or electrical shock.

## ⚠ WARNING



### Explosion Hazard

Use nonflammable cleaner.  
 Failure to do so can result in death, explosion, or fire.

Review this chart of troubleshooting tips first...you may not need to call for service at all.

## GENERAL OPERATION

| Problem                             | Possible Causes  | What to Do   |
|-------------------------------------|--|--|
| The refrigerator will not operate   | Not connected to an electrical supply.   | Plug the power cord into a grounded 3 prong outlet. Do not use an extension cord.  |
|                                     | No power to the electrical outlet.   | Plug in a lamp to see if the outlet is working.  |
|                                     | Household fuse blown or circuit breaker tripped.   | Replace the fuse or reset the circuit breaker. If the problem continues, contact an electrician.   |
|                                     | New installation.  | Allow 24 hours following installation for the refrigerator to cool completely.   |
| Runs too long, too frequently       | Today's refrigerators run more often to maintain temps and are more efficient than older models. |  |
|                                     | Normal at startup for new or recently installed units.   | Wait 24 hours for refrigerator to completely cool down (see "Temperature Controls" page).  |
|                                     | Prolonged or frequent door openings.   | This is normal. Minimize door openings.  |
|                                     | Door not sealing.  | Check to see if something is preventing door from closing.   |
|                                     | Front base grille blocked.   | Unblock to allow warm air to exit unit.  |
| The door will not close completely  | The door is blocked open.  | Move food packages away from door. Push bin or shelf back into the correct position. Make sure the crisper cover is fully pushed in, so that the back rests on the supports. |
| The door is difficult to open       | Gaskets are dirty or sticky.   | Clean gaskets and contact surfaces with mild soap and warm water.<br>Rinse and dry with soft cloth.  |
| Warm air from cabinet bottom        | This is normal air flow for condenser circulation.   |  |
| There is interior moisture buildup. | Humid room.  | Contributes to moisture buildup in the refrigerator.   |
|                                     | Door(s) opened often or not closed completely.   | Allows humid air to enter the refrigerator. Minimize door openings and keep door fully closed.   |
| Cabinet vibrates                    | Cabinet not level. Weak Floor.   | Level cabinet.   |
| Odor in cabinet                     | Odor producing foods not covered.  | Cover or wrap odorous foods tightly. Clean cabinet.  |

# TROUBLE SHOOTING GUIDE

## TEMPERATURE

| Problem                        | Possible Causes   | What to Do   |
|--------------------------------|---|--|
| Freezer, refrigerator too warm | New installation  | Allow 24 hours following installation for the refrigerator to cool completely. |
|                                | Control set too warm. Prolonged door openings.                          | Adjust temperature control. Minimize door openings.                            |
|                                | A large amount of warm food has been recently added.                    | Allow several hours for refrigerator to return to normal temperature.          |
|                                | Products with high sugar content may not harden completely when frozen. |  |
| Freezer, refrigerator too cold | Control set too cold.   | Adjust temperature control.  |

**NOTE:** If a temperature control button is blinking, an error or fault has been detected by the control. Contact Kenmore to arrange for service.

## NOISE

| Problem   | Possible Causes                 | What to Do  |
|---|---------------------------------|---|
| The refrigerator is noisy<br><br><b>NOTE:</b> Refrigerator noise has been reduced over the years. Due to this reduction in operating noise, you may notice unfamiliar noises that are normal. | Normal noise: clicking/Snapping | Valves opening or closing.  |
|   | Normal noise: pulsating         | Fans/compressor adjusting to optimize performance.                                      |
|   | Normal noise: sizzling/Gurgling | Water dripping on the heater during defrost cycle.                                      |
|   | Normal noise: popping           | Contraction/expansion of inside walls, especially during initial cool-down.             |
|   | Normal noise: water running     | May be heard when ice melts during the defrost cycle and water runs into the drain pan. |
|   | Cabinet not level               | Level cabinet.  |