

Scalable Stochastic Energy Planning Security, Resilience, and Algorithmic Performance

Dr.-Ing. Philipp Härtel

Senior Scientist Operations Research | Method Development | Energy Economics & System Analysis Division | Fraunhofer IEE
Senior Scientist | Sustainable Electrical Energy Systems | University of Kassel

Gurobi Energy Innovation Summit | Session Market Boundaries and System Resilience
24 June 2025 | Berlin

Contents

01

REWARDS

Robust development of the energy system to maintain energy security

02

EMPRISE

Stochastic system planning framework for integrated energy systems

03

Tuning PHA

From vanilla to effective and scalable progressive hedging on distributed HPC platforms

04

Takeaways

Bridging resilience and tractable energy system planning

Chapter 01

REWARDS

Resilient energy system planning to maintain energy security

Supported by:



on the basis of a decision
by the German Bundestag

REWARDS – Robust development of the energy system to maintain energy security

Motivation, objectives, and structure of the 3-year project (2024 – 2027)

Motivation

- **Need to conceptualise** energy security / security of supply / energy resilience / energy sovereignty / energy independence / ...
- **Exploring energy security and resilience concerns as additional layers** when planning system development pathways under uncertainty
- **New modelling capabilities** for dependencies, diversification, self-sufficiency, vulnerabilities, and reconstruction capabilities, ...

Objectives

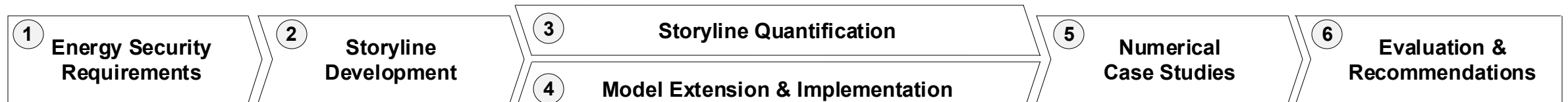
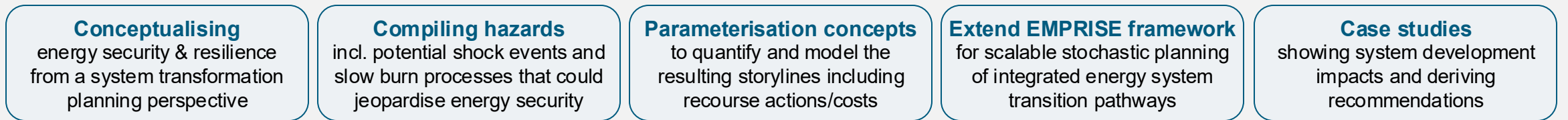

7 Open source tooling

4 Model extensions to incorporate critical aspects of energy security into the stochastic scenario trees

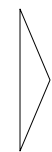
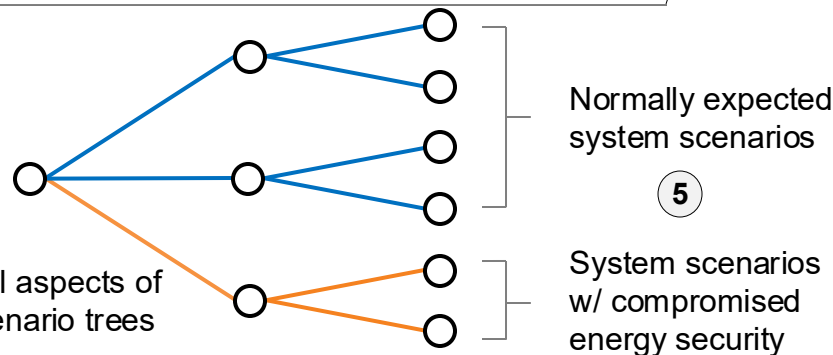

Robust decisions for transformation and system development pathways

6

REWARDS 02-03-04

What are potential hazards or threats? (just a selection)

Shock events

Hurricanes,
Tornadoes,
Storms

Flood,
Heavy rain

Tsunami,
Earthquake,
Volcanic activity

Extreme temperature,
Drought, Heat waves,
Forest fire

Extreme cold,
Snow storms,
Blizzards

Space weather

Physical
attacks

Cyber-physical
attacks

...



“(Cold) Dunkelflaute”

Uncontrollable
excess electricity
“(Helle Brise”)

Lack of cooling water
for power plants

War

Technology
dependency

Raw material
dependency

(Renewable) Fuel
import dependency

Climate change

Slow burn processes



REWARDS 02-03-04

Our recent preprint illustrates technical, economic, and environmental system performances during shock events and slow burn processes

Illustrative curves

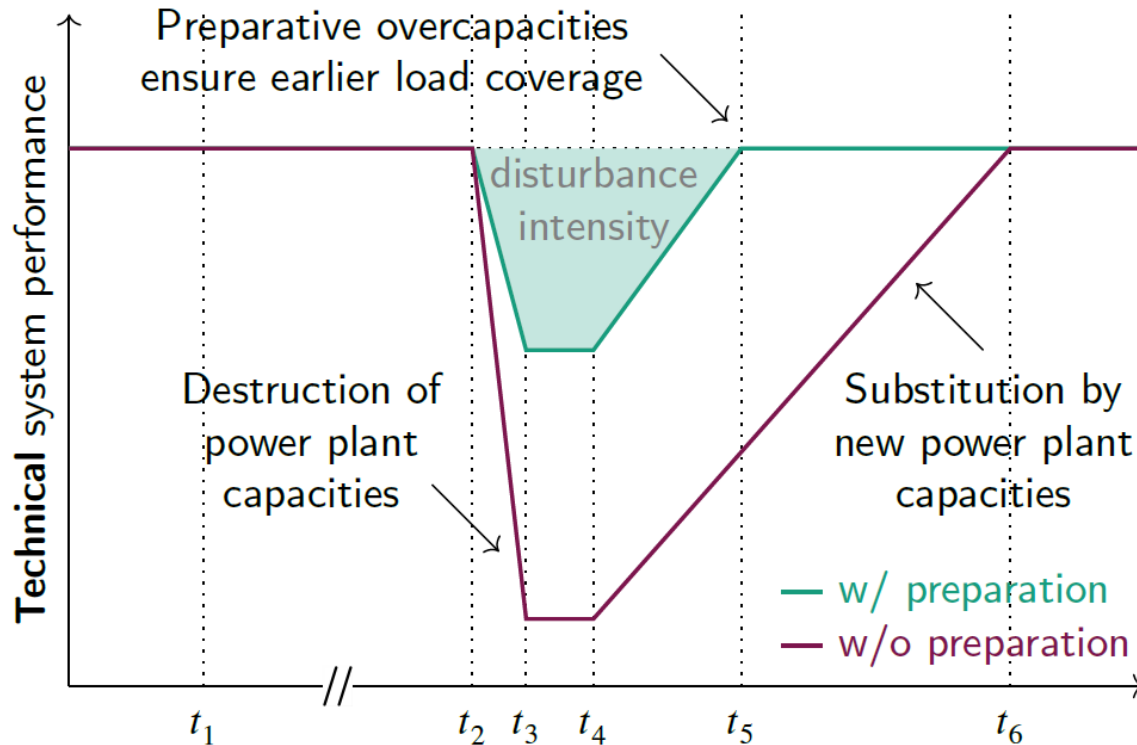

(a) Technical system performance during a shock event ⚡

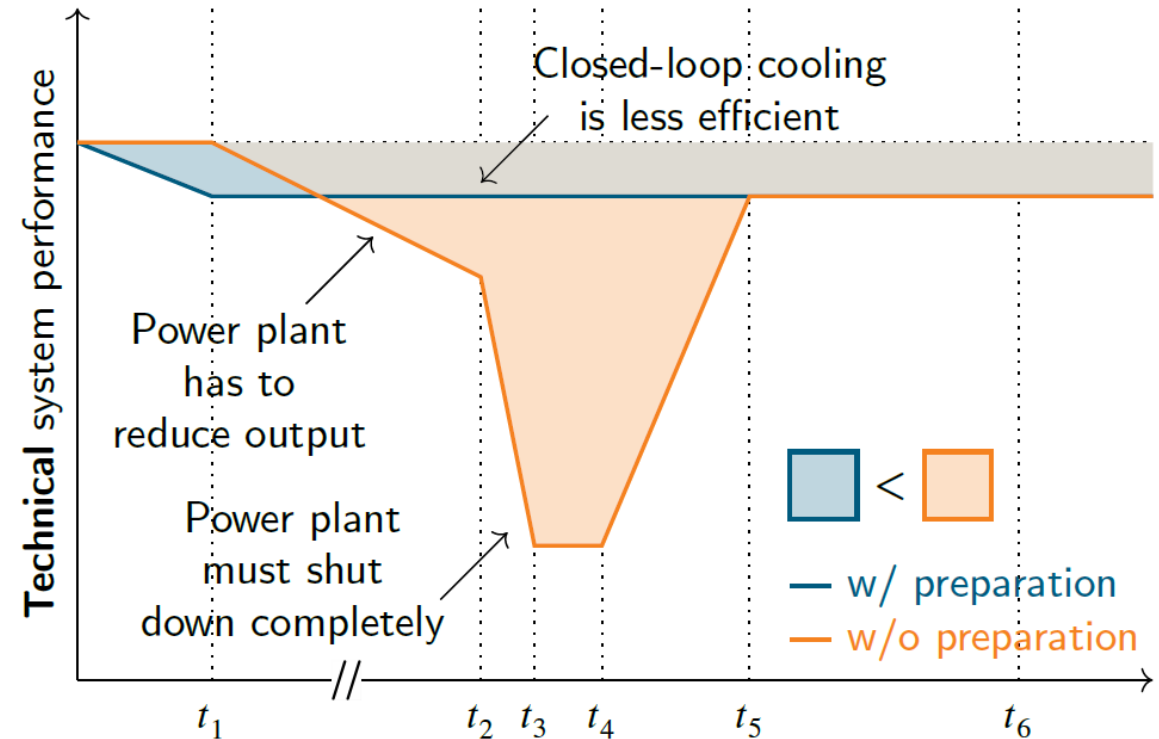

(b) Technical system performance during an SBP 🔥

How can systems react to disruptions and be more resilient? Let us look at the literature for a second

Resilience capacities (inspired by the literature)

- **Absorptive capacity (first level)** – the ability to withstand minor disturbances with normal operational system adjustments
- **Adaptive capacity (second level)** – the ability to adjust operations to accommodate more significant and/or extended disturbances
- **Transformative capacity (third level)** – the ability to fundamentally change system configurations to manage upcoming extreme and/or prolonged disturbances

What do resilience capacities mean for integrated energy systems in transformation, i.e. what are their recourse options as a response to shock events and slow burn processes?

Resilience capacities (inspired by the literature)

- **Absorptive capacity (first level)** – the ability to withstand minor disturbances with normal operational system adjustments
- **Adaptive capacity (second level)** – the ability to adjust operations to accommodate more significant and/or extended disturbances
- **Transformative capacity (third level)** – the ability to fundamentally change system configurations to manage upcoming extreme and/or prolonged disturbances

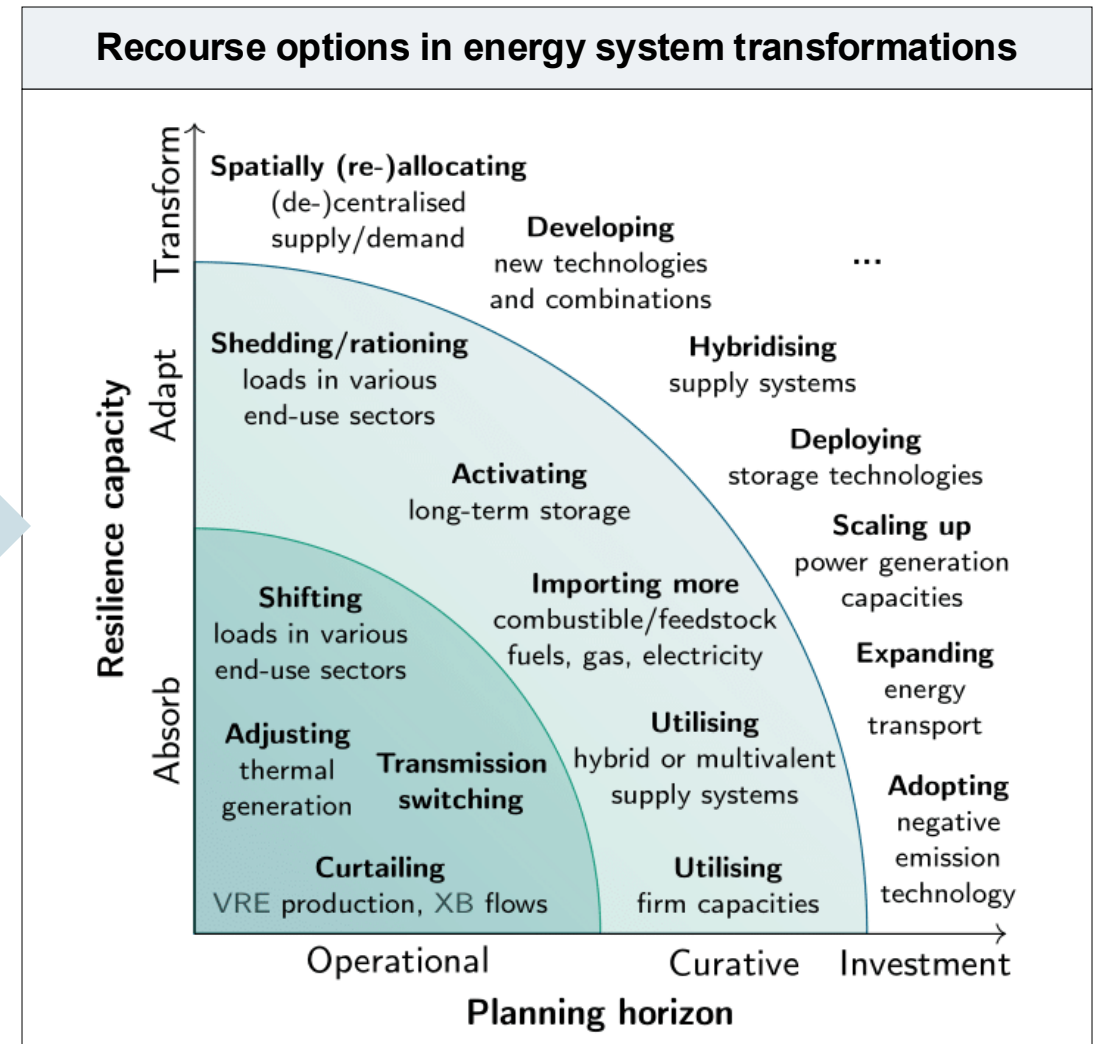

What are efficient trade-offs between system resilience and system costs?

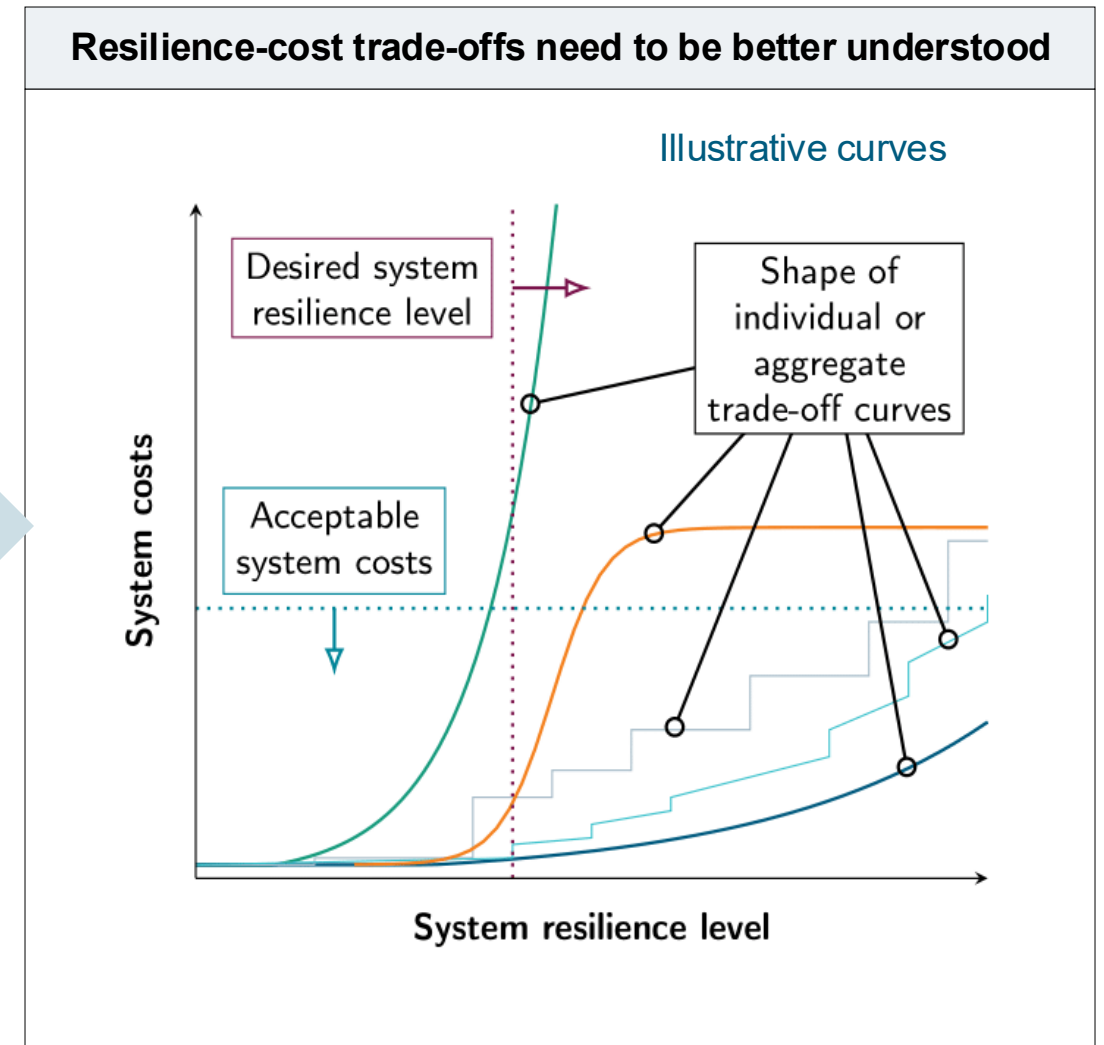
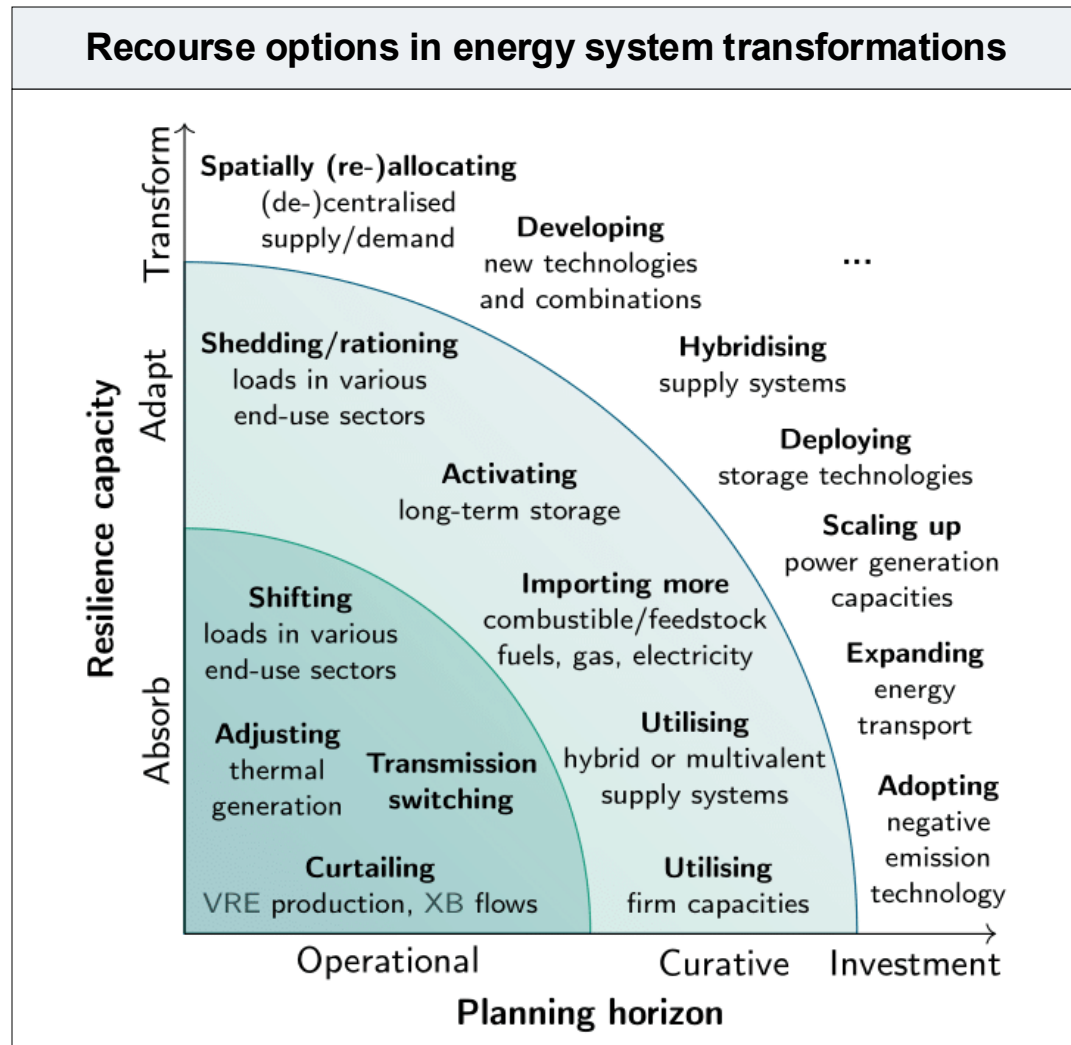

REWARDS 02-03-04

Chapter 02

EMPRISE

Stochastic Planning Framework for Integrated Energy Systems

EMPRISE (Environment for Modelling and Planning Robust Investments of Sector-integrated Energy systems) is a framework designed for parallel solution approaches

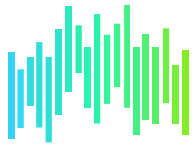

Environment for Modelling
and Planning Robust Investments of
Sector-integrated Energy systems

EMPRISE

Model instances cover **closed system development paths** of the integrated energy system (in Europe) with its internal and external interactions between technologies, commodities and markets **to optimise transformation pathways under uncertainty**



EMPRISE implementations feature generic modelling components and help to instantiate flexible scenario tree configurations

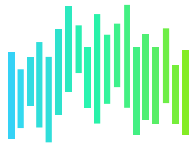

EMPRISE

Environment for Modelling and Planning Robust Investments of Sector-integrated Energy systems

Model instances cover **closed system development paths** of the integrated energy system (in Europe) with its internal and external interactions between technologies, commodities and markets **to optimise transformation pathways under uncertainty**

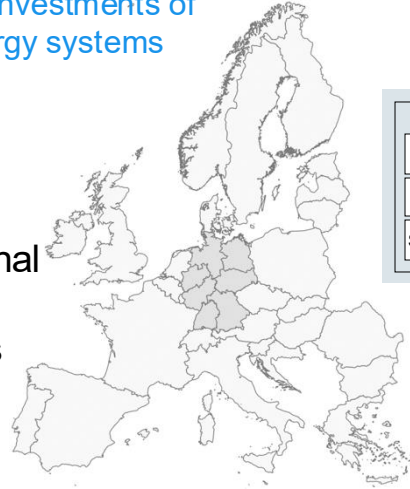

Generic modelling components (nodes, commodities, sources, sinks, links, converters)

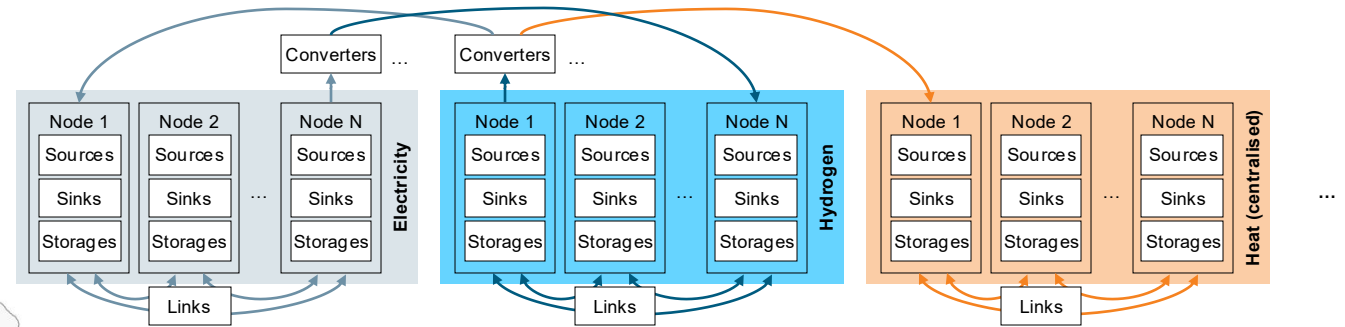

Largely agnostic towards new technologies, relevant commodities, and their combinations & Flexible scenario tree configurations

EMPRISE is a framework particularly designed for MPI-based parallel solution algorithms, e.g. scenario decomposition and progressive hedging algorithms



Environment for Modelling and Planning Robust Investments of Sector-integrated Energy systems

Model instances cover **closed system development paths** of the integrated energy system (in Europe) with its internal and external interactions between technologies, commodities and markets **to optimise transformation pathways under uncertainty**



Generic modelling components (nodes, commodities, sources, sinks, links, converters)

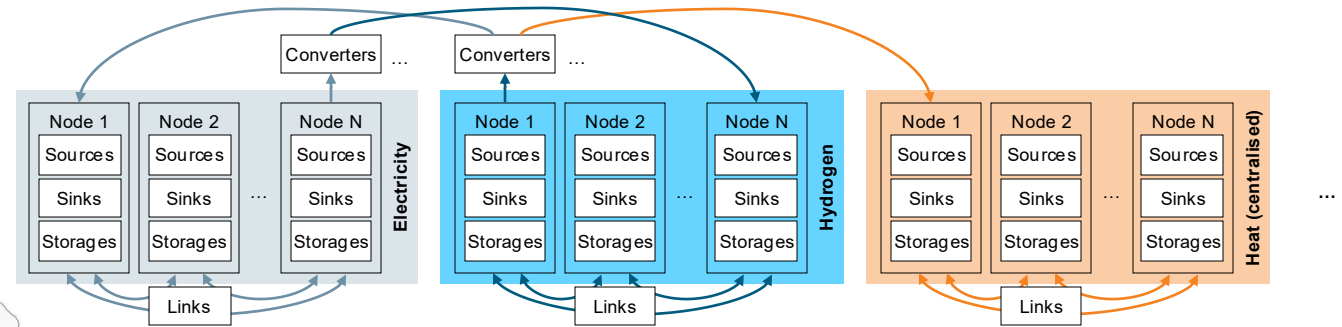

Largely agnostic towards new technologies, relevant commodities, and their combinations & Flexible scenario tree configurations

Objective function of the multi-stage stochastic problem

$$\min_{(x_1, y_1) \in X_1} \left\{ f_1(x_1, y_1) + \mathbf{E} \left[\min_{(x_2, y_2) \in X_2(x_1)} \left\{ f_2(x_2, y_2) + \dots + \mathbf{E} \left[\min_{(x_T, y_T) \in X_T(x_{T-1})} \{ f_T(x_T, y_T) \} \right] \right\} \right] \right\}$$

Investment costs
+ System operation costs
+ Decommissioning compensation

Investment costs
+ System operation costs
+ Decommissioning compensation

Investment costs
+ System operation costs (perpetual annuity)
+ Decommissioning compensation

Scalable solution approach

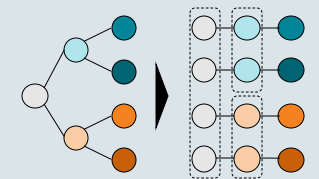

Scenario Decomposition
+ PHA + HPC platform

Chapter 03

Tuning PHA

From vanilla to effective progressive hedging on distributed HPC platforms

Tackling scalability with progressive hedging in EMPRISE

■ Current solution approach

- Scenario decomposition combined with a distributed **Progressive Hedging Algorithm (PHA)**
- Applied to **large-scale**, two-/multi-stage **stochastic EMPRISE** problem instances

■ Challenge

- **"Vanilla PHA" struggles** with real-world planning models
- **Poor numerical conditioning** is typical in energy system LPs (constraint matrices tend to be poorly scaled and ill-conditioned)

■ Need to do more

- **Standard PHA fails to converge** reliably for large, ill-conditioned energy models
- Call for **dedicated tuning** strategies!

Algorithm 1: Progressive Hedging (PH) for MSSPs

1 **Initialization:** Let $v \leftarrow 0$ and $w^{(t,v)}(\xi) \leftarrow 0, \forall \xi \in \Xi, t = 1, \dots, T$, and choose $\rho \in \mathbf{R}^+$. Compute for each $\xi \in \Xi$:

$$x^{(v+1)}(\xi) \in \operatorname{argmin}_x f_1(x^1) + \sum_{t=2}^T f_t(x^t, \bar{x}^{t-1}(\xi), \bar{\xi}^t)$$

2 **Iteration Update:** $v \leftarrow v + 1$

3 **Aggregation:** Compute for each $t = 1, \dots, T - 1$ and each $D \in \mathcal{G}_t$:

$$\bar{x}^{(v)}(D) \leftarrow \frac{\sum_{\xi \in D^{-1}} \pi_{\xi} x^{t,(v)}(\xi)}{\sum_{\xi \in D^{-1}} \pi_{\xi}}$$

4 **Price Update:** Compute for each $t = 1, \dots, T - 1$ and each $\xi \in \Xi$:

$$w^{(t,v)}(\xi) \leftarrow w^{(t,v-1)}(\xi) + \rho [x^{t,(v)}(\xi) - \bar{x}^{(v)}(\mathcal{G}_t(\xi))]$$

5 **Decomposition:** Compute for each $\xi \in \Xi$:

$$x^{(v+1)}(\xi) \in \operatorname{argmin}_x f_1(x^1) + \sum_{t=2}^T f_t(x^t, \bar{x}^{t-1}(\xi), \bar{\xi}^t) + \sum_{t=1}^{T-1} \left[w^{(t,v)}(\xi)^T x^t + \frac{\rho}{2} \|x^t - \bar{x}^{(v)}(\mathcal{G}_t(\xi))\|^2 \right]$$

6 **Termination:** If a criterion is met, stop. Otherwise, go to Step 2.

Combining adaptive rho heuristic with problem-specific initial rho scaling improves vanilla PHAs for energy system models

Adaptive rho heuristic

- **Scenario- and variable-specific update** of penalty parameters ρ
- **Heuristic based on primal/dual residuals**
(no convergence proof, but practically effective)
- **Enables convergence** where the standard PHA fails

Problem-specific initial rho scaling

- **Initialization of ρ** based on cost coefficients and model structure
- **Boosts convergence** toward tight optimality gaps

Combined approach and bounder information

- **Adaptive + problem-specific initialization** yields significant improvements in convergence behavior
- **Parallel bounds from scenario solvers** allow convergence monitoring despite heuristic tuning

Algorithm 1: Progressive Hedging (PH) for MSSPs

1 **Initialization:** Let $v \leftarrow 0$ and $w^{(t,v)}(\xi) \leftarrow 0, \forall \xi \in \Xi, t = 1, \dots, T$, and choose $\rho \in \mathbf{R}^+$. Compute for each $\xi \in \Xi$:

$$x^{(v+1)}(\xi) \in \operatorname{argmin}_x f_1(x^1) + \sum_{t=2}^T f_t(x^t, \bar{x}^{t-1}(\xi), \bar{\xi}^t)$$

2 **Iteration Update:** $v \leftarrow v + 1$

3 **Aggregation:** Compute for each $t = 1, \dots, T - 1$ and each $\mathcal{D} \in \mathcal{G}_t$:

$$\bar{x}^{(v)}(\mathcal{D}) \leftarrow \frac{\sum_{\xi \in \mathcal{D}^{-1}} \pi_{\xi} x^{t,(v)}(\xi)}{\sum_{\xi \in \mathcal{D}^{-1}} \pi_{\xi}}$$

4 **Price Update:** Compute for each $t = 1, \dots, T - 1$ and each $\xi \in \Xi$:

$$w^{(t,v)}(\xi) \leftarrow w^{(t,v-1)}(\xi) + \rho [x^{t,(v)}(\xi) - \bar{x}^{(v)}(\mathcal{G}_t(\xi))]$$

5 **Decomposition:** Compute for each $\xi \in \Xi$:

$$x^{(v+1)}(\xi) \in \operatorname{argmin}_x f_1(x^1) + \sum_{t=2}^T f_t(x^t, \bar{x}^{t-1}(\xi), \bar{\xi}^t) + \sum_{t=1}^{T-1} \left[w^{(t,v)}(\xi)^{\top} x^t + \frac{\rho}{2} \|x^t - \bar{x}^{(v)}(\mathcal{G}_t(\xi))\|^2 \right]$$

6 **Termination:** If a criterion is met, stop. Otherwise, go to Step 2.

Carefully tuned PHA enables tractable, distributed solving of high-dimensional, stochastic energy system models at scale

Two-stage stochastic EMPRISE instance

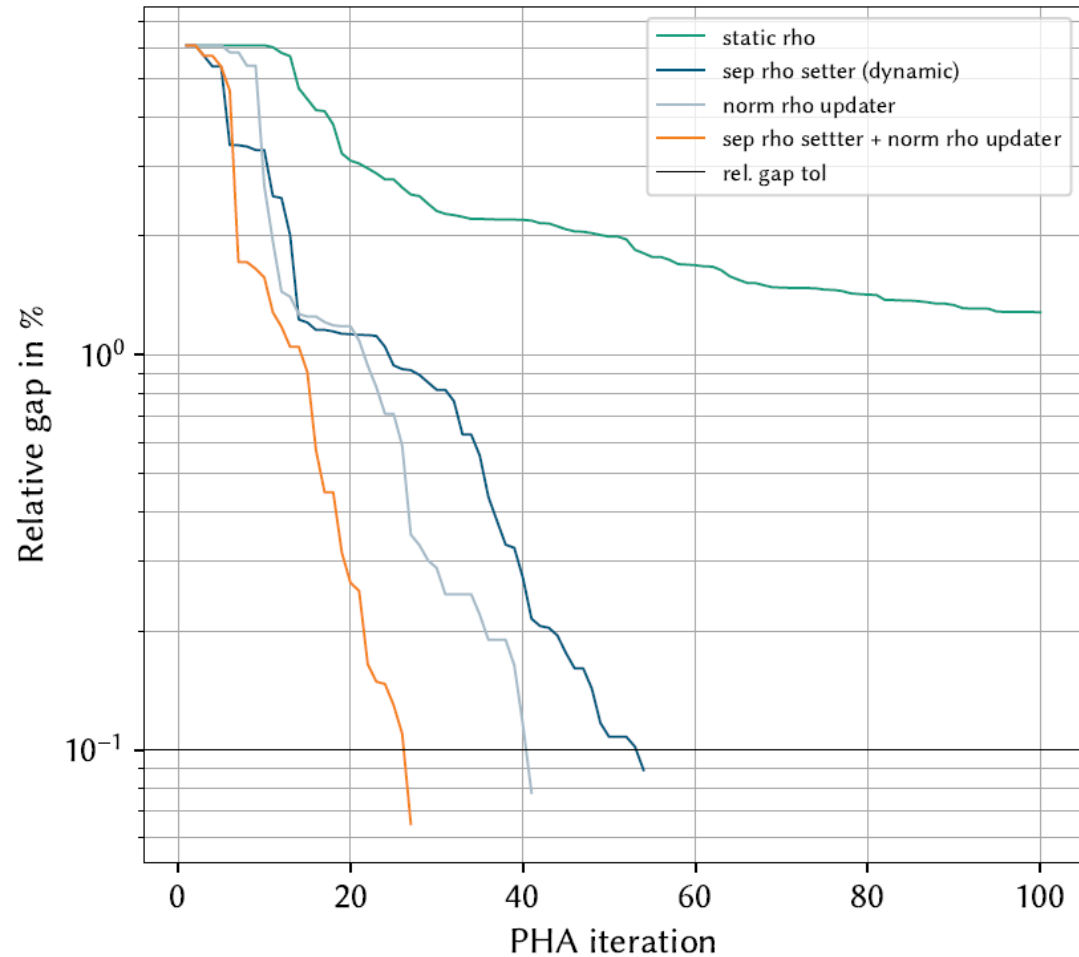

Multi-stage stochastic EMPRISE instance

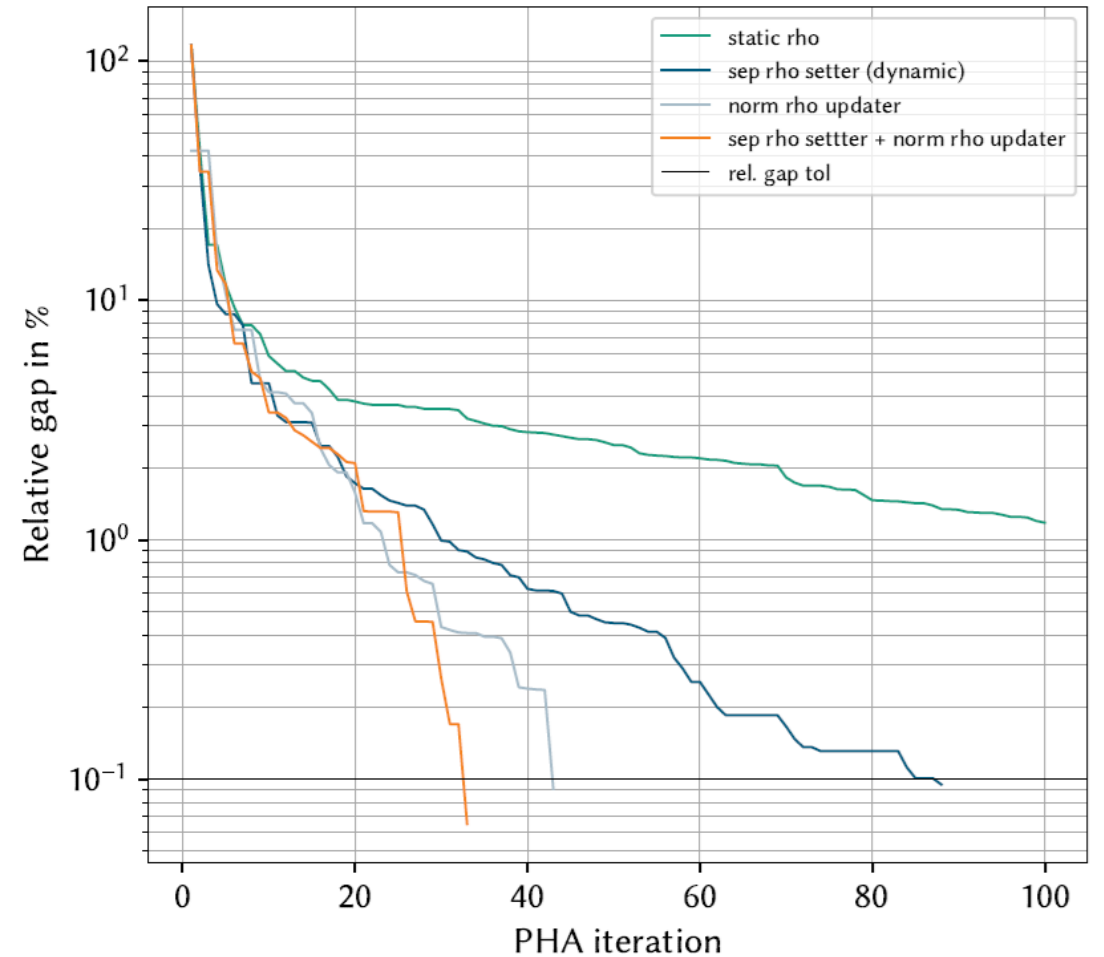

Chapter 04

Takeway

Bridging resilience and
tractable energy system planning

Takeaways from bridging resilience and tractable energy system planning

1

Research project **REWARDS** incorporates shock and slow-burn process events into energy system development analyses with qualitative and quantitative results to come

2

EMPRISE is a distributed (MPI-based) stochastic energy system planning framework to investigate multi-period system planning of integrated energy system transformations under uncertainty at scale

3

Problem-specific Progressive Hedging Algorithm tuning approaches help to make large-scale stochastic energy system planning problems tractable

Thank you very much for your attention!



Dr.-Ing. Philipp Härtel

Senior Scientist Operations Research
Team Lead Method Development
Energy Economics and System Analysis Division
Fraunhofer Institute for Energy Economics
and Energy System Technology IEE

Joseph-Beuys-Str. 8 | 34117 Kassel
Phone +49 561 7294-471
philipp.haertel@iee.fraunhofer.de

— Backup