



- U.S.A. : **KUBOTA TRACTOR CORPORATION**
3401 Del Amo Blvd., Torrance, CA 90503, U.S.A.
Telephone : (310)370-3370
- Western Division : 1175 S. Guild Av., Lodi, CA 95240
Telephone : (209)334-9910
- Central Division : 14855 FAA Blvd., Fort Worth, TX 76155
Telephone : (817)571-0900
- Northern Division : 6300 at One Kubota Way, Groveport, OH 43125
Telephone : (614)835-1100
- Southeast Division : 1025 Northbrook Parkway, Suwanee, GA 30024
Telephone : (770)995-8855
- Canada : **KUBOTA CANADA LTD.**
5900 14th Avenue, Markham, Ontario, L3S 4K4, Canada
Telephone : (905)294-7477
- France : **KUBOTA EUROPE S.A.S**
19-25, Rue Jules Vercey, Z.I. BP88, 95101 Argenteuil Cedex, France
Telephone : (33)1-3426-3434
- Italy : **KUBOTA EUROPE S.A.S Italy Branch**
Via Grandi, 29 20068 Peschiera Borrome (MI) Italy
Telephone : (39)02-51650377
- Germany : **KUBOTA (DEUTSCHLAND) GmbH**
Senefelder Str. 3-5 63110 Rodgau /Nieder-Roden, Germany
Telephone : (49)6106-873-0
- U.K. : **KUBOTA (U.K.) LTD.**
Dormer Road, Thame, Oxfordshire, OX9 3UN, U.K.
Telephone : (44)1844-214500
- Spain : **KUBOTA ESPAÑA S.A.**
Avenida Recomba No.5, Poligno Industrial la Laguna, Leganes, 28914 (Madrid) Spain
Telephone : (34)91-508-6442
- Australia : **KUBOTA TRACTOR AUSTRALIA PTY LTD.**
25-29 Permas Way, Truganina, VIC 3029, Australia
Telephone : (61)-3-9394-4400
- Malaysia : **SIME KUBOTA SDN. BHD.**
No.3 Jalan Sepadu 25/123 Taman Perindustrian Axis,
Seksyen 25, 40400 Shah Alam, Selangor Darul Ehsan Malaysia
Telephone : (60)3-736-1388
- Philippines : **KUBOTA PHILIPPINES, INC.**
232 Quirino Highway, Baesa, Quezon City 1106, Philippines
Telephone : (63)2-422-3500
- Taiwan : **SHIN TAIWAN AGRICULTURAL MACHINERY CO., LTD.**
16, Fengping 2nd Rd, Taliiao Shiang Kaohsiung 83107, Taiwan R.O.C.
Telephone : (886)7-702-2333
- Indonesia : **PT KUBOTA MACHINERY INDONESIA**
Tower A at EightyEight@Kasablanka Lantai 16
Jalan Raya Casablanka Kav. 88, Jakarta 12870 Indonesia
Telephone : (62)-21-29568-720
- Thailand : **SIAM KUBOTA CORPORATION CO., LTD.**
101/19-24 Moo 20, Navanakorn Industrial Estate, Tambon Khlongnueng, Amphur Khlongluang,
Pathumthani 12120, THAILAND
Telephone : (66)2-909-0300
- Korea : **KUBOTA KOREA CO., LTD.**
41-27, Jayumyeok-gil, Baeksan-myeon, Gimje-si, Jeollabuk-do, Korea
Telephone : (82)-63-544-5822
- India : **KUBOTA AGRICULTURAL MACHINERY INDIA PVT. LTD.**
No.15, Medavakkam Road, Sholinganallur, Chennai-600119, T.N., India
Telephone : (91)44-6104-1500
- Vietnam : **KUBOTA VIETNAM CO., LTD.**
Lot B-3A2-CN, My Phuoc 3 Industrial Park, Ben Cat District, Binh Duong Province, Vietnam
Telephone : (84)-650-3577-507

KUBOTA Corporation

English (U.S.A.)
Code No. TD350-1958-2

OPERATOR'S MANUAL

KUBOTA TRACTOR

MODELS L3560·L4060·L4760
L5060·L5460·L6060

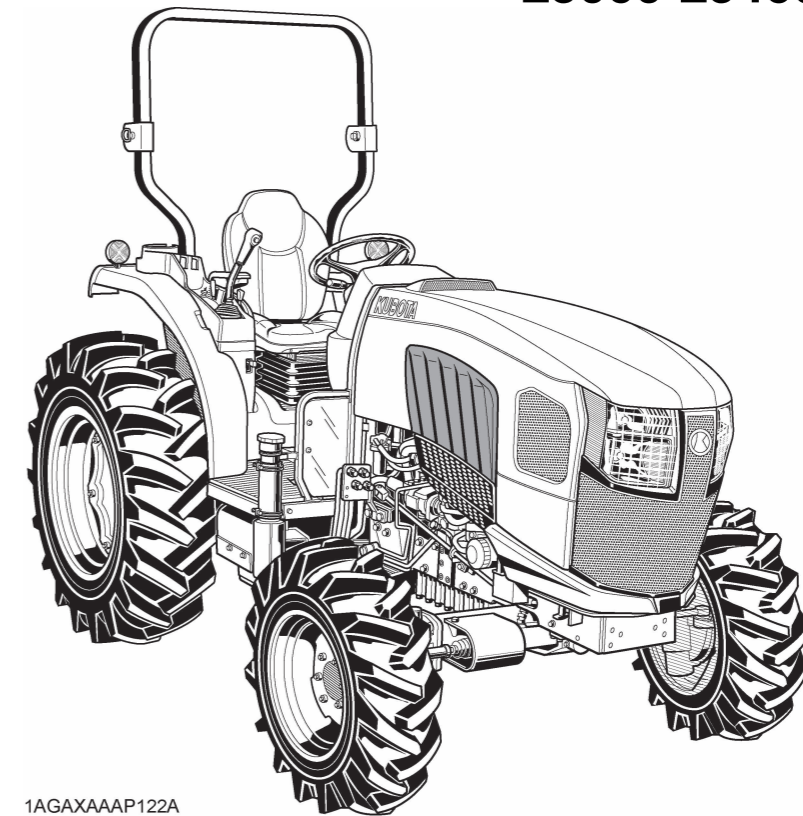

1AGAXAAP122A

L
3
5
6
0
·
L
4
0
6
0
·
L
4
7
6
0
·
L
5
0
6
0
·
L
5
4
6
0
·
L
6
0
6
0

READ AND SAVE THIS MANUAL



ABBREVIATION LIST

Abbreviations	Definitions
2WD	2 Wheel Drive
4WD	4 Wheel Drive
API	American Petroleum Institute
ASABE	American Society of Agricultural and Biological Engineers, USA
ASTM	American Society for Testing and Materials, USA
DIN	Deutsches Institut für Normung, GERMANY
DT	Dual Traction [4WD]
fpm	Feet Per Minute
GST	Glide Shift Transmission
Hi-Lo	High Speed-Low Speed
HST	Hydrostatic Transmission
m/s	Meters Per Second
PTO	Power Take Off
RH/LH	Right-hand and left-hand sides are determined by facing in the direction of forward travel
ROPS	Roll-Over Protective Structures
rpm	Revolutions Per Minute
r/s	Revolutions Per Second
SAE	Society of Automotive Engineers, USA
SMV	Slow Moving Vehicle

California Proposition 65

WARNING

Engine exhaust, some of its constituents, certain vehicle components and fluids, contain or emit chemicals known to the State of California to cause cancer and birth defects or other reproductive harm.

KUBOTA Corporation is ...

Since its inception in 1890, KUBOTA Corporation has grown to rank as one of the major firms in Japan.

To achieve this status, the company has through the years diversified the range of its products and services to a remarkable extent, until today, 19 plants and 16,000 employees produce over 1,000 different items, large and small.

All these products and all the services which accompany them, however, are unified by one central commitment. KUBOTA makes products which, taken on a national scale, are basic necessities. Products which are indispensable, products intended to help individuals and nations fulfill the potential inherent in their environment. For KUBOTA is the Basic Necessities Giant.

This potential includes water supply, food from the soil and from the sea, industrial development, architecture and construction, and transportation.

Thousands of people depend on KUBOTA's know-how, technology, experience and customer service. You too can depend on KUBOTA.

UNIVERSAL SYMBOLS

As a guide to the operation of your tractor, various universal symbols have been utilized on the instruments and controls. The symbols are shown below with an indication of their meaning.

	Safety Alert Symbol		3-Point Lowering Speed Control
	Diesel Fuel		Remote Cylinder-Retract
	Fuel-Level		Remote Cylinder-Extend
	Engine-Rotational Speed		Steering Wheel-Tilt Control
	Hourmeter/Elapsed Operating Hours		Hazard Warning Lights
	Engine Coolant-Temperature		Master Lighting Switch
	Diesel Preheat/Glow Plugs (Low Temperature Start Aid)		Position Lamps
	Brake System		Headlight-Low Beam
	Clutch		Headlight-High Beam
	Parking Brake		Audible Warning Device
	Engine Intake/Combustion Air-Filter		4-Wheel Drive-On
	Battery Charging Condition		4-Wheel Drive-Off
	Engine Oil-Pressure		Fast
	Turn Signal		Slow
	Engine-Stop		Creep
	Engine-Run		Read Operator's Manual
	Starter Control		Tractor-Forward Movement-Overhead View of Machine
	Power Take-Off Clutch Control-Off Position		Tractor-Rearward Movement-Overhead View of Machine
	Power Take-Off Clutch Control-On Position		Engine Speed Control
	Differential Lock		Regeneration
	Position Control-Raised Position		DPF INHIBIT (Switch)
	Position Control-Lowered Position		Regeneration (Switch)
	Engine Warning		Parked Regeneration
	Emission Control		Engine RPM Increase
	Draft Control-Shallow Position		
	Draft Control-Deep Position		

FOREWORD

You are now the proud owner of a KUBOTA Tractor. This tractor is a product of KUBOTA quality engineering and manufacturing. It is made of fine materials and under a rigid quality control system. It will give you long, satisfactory service. To obtain the best use of your tractor, please read this manual carefully. If your tractor is provided with CAB, also read the CAB operator's manual, which is a separate manual. It will help you become familiar with the operation of the tractor and contains many helpful hints about tractor maintenance. It is KUBOTA's policy to utilize as quickly as possible every advance in our research. The immediate use of new techniques in the manufacture of products may cause some small parts of this manual to be outdated. KUBOTA distributors and dealers will have the most up-to-date information. Please do not hesitate to consult with them.



SAFETY FIRST

This symbol, the industry's "Safety Alert Symbol", is used throughout this manual and on labels on the machine itself to warn of the possibility of personal injury. Read these instructions carefully. It is essential that you read the instructions and safety regulations before you attempt to assemble or use this unit.



DANGER : Indicates an imminently hazardous situation which, if not avoided, will result in death or serious injury.



WARNING : Indicates a potentially hazardous situation which, if not avoided, could result in death or serious injury.



CAUTION : Indicates a potentially hazardous situation which, if not avoided, could result in minor or moderate injury.

IMPORTANT : Indicates that equipment or property damage could result if instructions are not followed.

NOTE : Gives helpful information.

CONTENTS

- ▲ SAFE OPERATION ▲-1
- SERVICING OF TRACTOR..... 1
- SPECIFICATIONS..... 3
 - SPECIFICATION TABLE [HST Type] 3
 - SPECIFICATION TABLE [GST type] 5
 - SPECIFICATION TABLE [Manual Transmission Type] 7
 - TRAVELING SPEEDS 9
 - HST Type.....9
 - GST type.....10
 - Manual Transmission Type.....11
- IMPLEMENT LIMITATIONS 12
- INSTRUMENT PANEL AND CONTROLS..... 14
- PRE-OPERATION CHECK 19
 - DAILY CHECK 19
- OPERATING THE ENGINE..... 20
 - EXHAUST AFTERTREATMENT DEVICES..... 20
 - Diesel Particulate Filter (DPF) Muffler 20
 - Handling Points..... 21
 - DPF Regeneration Process 21
 - Regeneration Operating Procedure..... 22
 - PM Warning Level and Required Procedures 23
 - Regeneration Operating Procedure..... 24
 - PM Warning Level and Required Procedures 25
 - Tips on Diesel Particulate Filter (DPF) Regeneration..... 27
- STARTING THE ENGINE 27
- COLD WEATHER STARTING 32
 - Antifrost Heater for Oil Separator (if equipped) 32
 - Block Heater (if equipped) 32
- STOPPING THE ENGINE..... 33
- WARMING UP 33
 - Warm-Up Transmission Oil in the Low Temperature Range 33
- JUMP STARTING 34
- OPERATING THE TRACTOR..... 35
 - OPERATING NEW TRACTOR 35
 - Do not Operate the Tractor at Full Speed for the First 50 Hours..... 35
 - Changing Lubricating Oil for New Tractors..... 35
 - BOARDING AND LEAVING THE TRACTOR 35
 - OPERATING FOLDABLE ROPS (if equipped)..... 35
 - To Fold the ROPS 35
 - To Raise the ROPS to Upright Position..... 36
 - Adjustment of Foldable ROPS..... 37
 - STARTING 37
 - Operator's Seat..... 37

Glove Box	38
Seat Belt	38
Tilt Steering Adjustment.....	38
Light Switch	39
Turn Signal / Hazard Light Switch	39
Horn Button (if equipped).....	39
Side Work Light Switch.....	40
Tractor Lights.....	40
Brake Pedals (Right and Left).....	41
Clutch Pedal	42
HST Response Control.....	43
H-DS (Hydro Dual Speed) Lever	44
HST Mode.....	45
Throttle-Up Switch	47
Range Gear Shift Lever (L-M-H).....	48
Front Wheel Drive Lever.....	48
Hand Throttle Lever.....	49
Parking Brake	49
Speed Control Pedal.....	49
Cruise Control.....	50
ATA (Auto Throttle Advance) Switch	51
Shuttle Shift Lever	52
Main Gear Shift Lever.....	53
Creep Gear Shift Lever (if equipped).....	54
Front Wheel Drive Lever.....	54
Hand Throttle Lever.....	55
Foot Throttle	55
Parking Brake	55
Main Gear Shift Lever.....	56
Range Gear Shift Lever (Hi-Lo).....	56
Synchro-Shuttle Shift Lever	56
Creep Gear Shift Lever (if equipped).....	57
Front Wheel Drive Lever.....	57
Hand Throttle Lever.....	58
Foot Throttle	58
Parking Brake	58
STOPPING.....	58
Stopping.....	58
INTELLIPANEL (TM).....	59
Changing Display Mode.....	59
Resetting the Trip Meter and Setting the Clock.....	60
SERVICE INSPECT mode displaying/resetting procedure	61
CHECK DURING DRIVING	62
IntelliPanel(TM) Message	62
Immediately Stop the Engine if:	62
Easy Checker(TM).....	63
Fuel Gauge.....	63
Coolant Temperature Gauge.....	64
Tachometer.....	64
PARKING	64
Parking.....	64
OPERATING TECHNIQUES	65

Differential Lock	65
Operating the Tractor on a Road	65
Operating on Slopes and Rough Terrain	66
Transport the Tractor Safely	66
Directions for Use of Power Steering	66
Electrical Outlet	66
PTO	67
PTO OPERATION	67
PTO Clutch Control Switch	67
Mid-PTO (if equipped)	68
Stationary PTO	69
IntelliPanel (TM) Message	69
PTO Shaft Cover and Shaft Cap	70
3-POINT HITCH & DRAWBAR	71
3-POINT HITCH	72
Category 1 & 2	72
Category 1	72
Selecting the top link mounting holes	72
Drawbar	72
Lifting Rod (Right)	73
Top Link	73
Telescopic Stabilizers	73
Telescopic Lower Links	73
DRAWBAR	74
Adjusting Drawbar Length	74
Swing Drawbar	74
HYDRAULIC UNIT	75
3-POINT HITCH CONTROL SYSTEM	75
Position Control	75
Draft Control (if equipped)	75
Mixed Control	76
Float Control	76
3-point Hitch Lowering Speed	76
DUAL REMOTE HYDRAULIC CONTROL SYSTEM	76
Control Lever and Hydraulic Hose Connections	76
Loader / Remote Control Valve Lever	77
Valve Lock	78
REMOTE HYDRAULIC CONTROL SYSTEM (if equipped)	78
Remote Control Valve	78
Remote Control Valve Lever	78
Remote Control Valve Coupler Connecting and Disconnecting	79
Hydraulic Control Unit Use Reference Chart	80
TIRES, WHEELS AND BALLAST	81
TIRES	81
Inflation Pressure	81
Dual Tires	81
WHEEL ADJUSTMENT	81
Front Wheels (with 4-wheel drive)	81
Rear Wheels	83

BALLAST	84
Front Ballast.....	84
Rear Ballast	85
Liquid Ballast in Rear Tires.....	85
MAINTENANCE.....	86
SERVICE INTERVALS	86
LUBRICANTS, FUEL AND COOLANT	89
PERIODIC SERVICE.....	91
HOW TO OPEN THE HOOD	91
Hood	91
Side Cover	91
Floor Sheet	91
DAILY CHECK	92
Walk Around Inspection.....	92
Checking and Refueling.....	92
Checking Water Separator	92
Checking Engine Oil Level.....	93
Checking Transmission Fluid Level	93
Checking Coolant Level.....	93
Checking Dust Indicator.....	94
Cleaning Grill, Radiator Screen and Oil Cooler	94
Checking DPF Muffler.....	95
Checking Brake Pedal	96
Checking Brake Pedals and Clutch Pedal	96
Checking Gauges, Meter and Easy Checker(TM)	96
Checking Head Light, Turn Signal / Hazard Light etc.....	96
Checking Seat Belt and ROPS	96
Checking Movable Parts.....	96
EVERY 50 HOURS	96
Lubricating Grease Fittings.....	96
Checking Engine Start System	97
Checking Operator Presence Control.....	98
Checking Wheel Bolt Torque	99
EVERY 100 HOURS	99
Cleaning Air Cleaner Primary Element.....	99
Adjusting Fan Belt Tension.....	99
Adjusting Clutch Pedal.....	100
Adjusting Brake Pedal	100
Checking Battery Condition	101
EVERY 200 HOURS	102
Replacing Transmission Oil Filter [HST Type].....	102
Adjusting Toe-in.....	103
EVERY 400 HOURS	103
Changing Engine Oil.....	103
Replacing Engine Oil Filter	104
Changing Transmission Fluid / Replacing Hydraulic Oil Filter.....	104
Changing Front Axle Case Oil	106
Replacing Fuel Filter.....	106
Cleaning Water Separator	107
EVERY 600 HOURS	107

Adjusting Front Axle Pivot.....	107
EVERY 800 HOURS	107
Adjusting Engine Valve Clearance	107
EVERY 1000 HOURS or 1 YEAR.....	107
Replacing Air Cleaner Primary Element and Secondary Element.....	107
Checking Exhaust Manifold	107
EVERY 1500 HOURS	107
Cleaning Fuel Injector Nozzle Tip.....	107
Replacing Oil Separator Element	108
Checking PCV (Positive Crankcase Ventilation) Valve	108
Checking and Cleaning EGR Cooler	108
EVERY 2000 HOURS or 2 YEARS.....	108
Flushing Cooling System and Changing Coolant	108
Anti-Freeze	109
EVERY 3000 HOURS	109
Checking Turbocharger	109
Checking Supply Pump	109
Checking and Cleaning EGR System.....	109
Cleaning DPF Muffler	110
EVERY 1 YEAR	110
Checking Fuel Line	110
Checking Intake Air Line.....	110
Checking Radiator Hose and Clamp	111
Checking Power Steering Line	111
Checking Oil Cooler Line [HST Type].....	112
Checking Oil Separator Hose	112
Checking Antifrost Heater for Oil Separator	112
Checking Lift Cylinder Hose	112
Checking DPF Differential Pressure Sensor Pipe	112
Checking EGR Pipe.....	112
EVERY 2 YEARS	112
Replacing DPF Differential Pressure Sensor Hose	112
Replacing Boost Sensor Hose.....	112
EVERY 4 YEARS	112
Replacing Radiator Hose (Water pipes)	112
Replacing Fuel Hose	112
Replacing Intake Air Line.....	112
Replacing Oil Cooler Line [HST Type].....	113
Replacing Oil Separator Hose	113
Replacing Power Steering Hose.....	113
Replacing Lift Cylinder Hose	113
SERVICE AS REQUIRED.....	113
Bleeding Fuel System.....	113
Draining Clutch Housing Water	113
Replacing Fuse.....	114
Replacing Slow-Blow Fuses	115
Replacing Light Bulb.....	115
Replacing Head Lamp	116
Replacing Radiator Hose (Water pipes)	116
Replacing Fuel Hose	116
Replacing Intake Air Line.....	116
Replacing Power Steering Hose.....	116

CONTENTS

Replacing Oil Cooler Line [HST Type].....	116
Replacing Oil Separator Hose	116
STORAGE	117
TRACTOR STORAGE	117
REMOVING THE TRACTOR FROM STORAGE	117
TROUBLESHOOTING.....	118
ENGINE TROUBLESHOOTING	118
HST (Hydrostatic Transmission) TROUBLESHOOTING	119
GST (Glide Shift Transmission) TROUBLESHOOTING	121
MT(Manual Transmission) TROUBLESHOOTING	123
OPTIONS.....	124
APPENDICES.....	125
INDEX	125



SAFE OPERATION

Careful operation is your best insurance against an accident.

Read and understand this manual carefully before operating the tractor.

All operators, no matter how much experience they may have, should read this and other related manuals before operating the tractor or any implement attached to it. It is the owner's obligation to instruct all operators in safe operation.

1. BEFORE OPERATING THE TRACTOR

1. Know your equipment and its limitations. Read this entire manual before attempting to start and operate the tractor.
2. Pay special attention to the danger, warning and caution labels on the tractor.
3. Do not operate the tractor or any implement attached to it while under the influence of alcohol, medication, controlled substances or while fatigued.
4. Before allowing other people to use your tractor, explain how to operate and have them read this manual before operation.
5. Never wear loose, torn, or bulky clothing around tractor. It may catch on moving parts or controls, leading to the risk of an accident. Use additional safety items, e.g. hard hat, safety boots or shoes, eye and hearing protection, gloves, etc., as appropriate or required.
6. Do not allow passengers to ride on any part of the tractor at anytime. The operator must remain in the tractor seat during operation.
7. Check brakes, clutch, linkage pins and other mechanical parts for improper adjustment and wear. Replace worn or damaged parts promptly. Check the tightness of all nuts and bolts regularly. (For further details, see "MAINTENANCE" section.)
8. Keep your tractor clean. Dirt, grease, and trash build up may contribute to fires and lead to personal injury.
9. Use only implements meeting the specifications listed under "IMPLEMENT LIMITATIONS" in this manual or implements approved by KUBOTA.
10. Use proper weights on the front or rear of the tractor to reduce the risk of upsets. When using the front loader, put an implement or ballast on the 3-point hitch to improve stability. Follow the safe operating procedures specified in the implement or attachment manual.
11. The narrower the tread, the greater the risk of a tractor upset. For maximum stability, adjust the wheels to the widest practical tread width for your application. (See "TIRES, WHEELS AND BALLAST" section.)

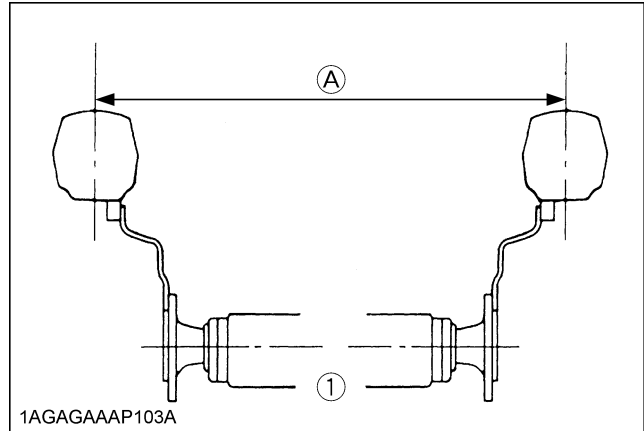

(1) Rear wheels

(A) Tread Width

12. Do not modify the tractor. Unauthorized modification may affect the function of the tractor, which may result in personal injury.

◆ CAB, ROPS

1. KUBOTA recommends the use of a CAB or Roll Over Protective Structures (ROPS) and seat belt in almost all applications. This combination will reduce the risk of serious injury or death, should the tractor be upset. Check for overhead clearance which may interfere with a CAB or ROPS.
2. Set parking brake and stop engine. Remove any obstruction that may prevent raising or folding of the ROPS. Do not allow any bystanders. Always perform function from a stable position at the rear of the tractor. Hold the top of the ROPS securely when raising or folding. Make sure all pins are installed and locked.
3. If the CAB or ROPS is loosened or removed for any reason, make sure that all parts are reinstalled correctly before operating the tractor.
4. Never modify or repair any structural member of a CAB or ROPS because welding, bending, drilling, grinding, or cutting may weaken the structure.
5. A damaged CAB or ROPS structure must be replaced, not repaired or revised.
6. If any structural member of the CAB or ROPS is damaged, replace the entire structure at your local KUBOTA Dealer.

▲-2 SAFE OPERATION

7. If the tractor is equipped with a foldable ROPS it may be temporarily folded down only when absolutely necessary for areas with height constraints. (There is no operator protection provided by the ROPS in the folded position. For operator safety the ROPS should be placed in the upright and locked position and the seat belt fastened for all other operations.)
8. Always use the seat belt if the tractor has a CAB or ROPS.
Do not use the seat belt if a foldable ROPS is down or there is no ROPS. Check the seat belt regularly and replace if frayed or damaged.

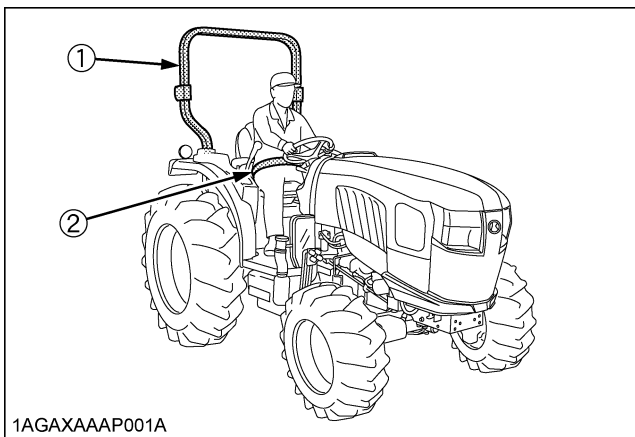

1AGAXAAP001A

- (1) ROPS
(2) Seat belt

2. OPERATING THE TRACTOR

Operator safety is a priority. Safe operation, specifically with respect to overturning hazards, entails understanding the equipment and environmental conditions at the time of use. Some prohibited uses which can affect overturning hazards include traveling and turning with implements and loads carried too high etc. This manual sets forth some of the obvious risks, but the list is not, and cannot be, exhaustive. It is the operator's responsibility to be alert for any equipment or environmental condition that could compromise safe operation.

◆ Starting

1. Always sit in the operator's seat when starting engine or operating levers or controls. Adjust seat per instructions in the operating the tractor section. Never start engine while standing on the ground.
2. Before starting the engine, make sure that all levers (including auxiliary control levers) are in their neutral positions, that the parking brake is engaged, and that both the clutch and the Power Take-Off (PTO) are disengaged or "OFF".
Fasten the seat belt if the tractor has a CAB or a foldable ROPS in the upright and locked position.

3. Do not start engine by shorting across starter terminals or bypassing the safety start switch. Machine may start in gear and move if normal starting circuitry is bypassed.
4. Do not operate or idle engine in a non-ventilated area. Carbon monoxide gas is colorless, odorless, and deadly.
5. Check before each use that operator presence controls are functioning correctly. Test safety systems. (See "Checking Engine Start System" in "EVERY 50 HOURS" in "PERIODIC SERVICE" section.)
Do not operate unless they are functioning correctly.

◆ Working

1. Pull only from the drawbar. Never hitch to axle housing or any other point except drawbar; such arrangements will increase the risk of serious personal injury or death due to a tractor upset.

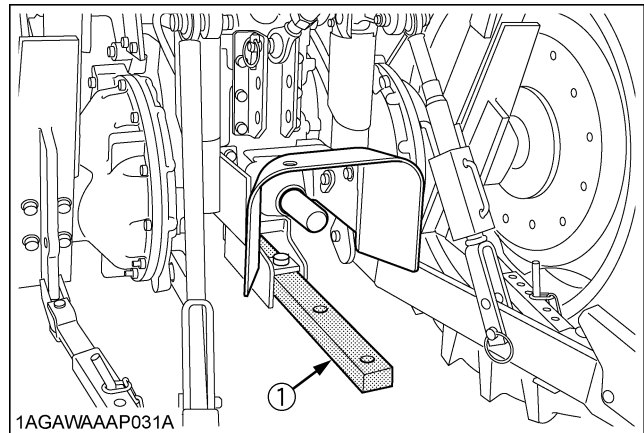

1AGAWAAP031A

- (1) Drawbar

2. For trailing PTO-driven implements, set the drawbar to the towing position.
3. Attach pulled or towed loads to the drawbar only.
4. Keep all shields and guards in place. Replace any that are missing or damaged.
5. Avoid sudden starts. To avoid upsets, slow down when turning, on uneven ground, and before stopping.
6. The tractor cannot turn with the differential locked and attempting to do so could be dangerous.
7. Do not operate near ditches, holes, embankments, or other ground surface features which may collapse under the tractor's weight. The risk of tractor upset is even higher when the ground is loose or wet. Tall grass can hide obstacles, walk the area first to be sure.
8. Watch where you are going at all times. Watch for and avoid obstacles. Be alert at row ends, near trees, and other obstructions.
9. When working in groups, always let the others know what you are going to do before you do it.
10. Never try to get on or off a moving tractor.
11. Always sit in the operator's seat when operating levers or controls.
12. Do not stand between tractor and implement or trailed vehicle unless parking brake is applied.

◆ Safety for children

Tragedy can occur if the operator is not alert to the presence of children. Children generally are attracted to machines and the work they do.

1. Never assume that children will remain where you last saw them.
2. Keep children out of the work area and under the watchful eye of another responsible adult.
3. Be alert and shut your machine down if children enter the work area.
4. Never carry children on your machine. There is no safe place for them to ride. They may fall off and be run over or interfere with your control of the machine.
5. Never allow children to operate the machine even under adult supervision.
6. Never allow children to play on the machine or on the implement.
7. Use extra caution when backing up. Look behind and down to make sure area is clear before moving.

◆ Operating on slopes

Slopes are a major factor related to loss-of-control and tip-over accidents, which can result in severe injury or death. All slopes require extra caution.

1. To avoid upsets, always back up steep slopes. If you cannot back up the slope or if you feel uneasy on it, do not operate on it. Stay off slopes too steep for safe operation.
2. Driving forward out of a ditch, mired condition or up a steep slope increases the risk of a tractor to be upset backward. Always back out of these situations. Extra caution is required with 4-wheel drive models because their increased traction can give the operator false confidence in the tractor's ability to climb slopes.
3. Keep all movement on slopes slow and gradual. Do not make sudden changes in speed, direction or apply brake and make sudden motions of the steering wheel.
4. Avoid disengaging the clutch or changing gears speed when climbing or going down a slope. If on a slope disengaging the clutch or changing gears to neutral could cause loss of control.
5. Special attention should be made to the weight and location of implements and loads as such will affect the stability of the tractor.
6. To improve stability on slope, set widest wheel tread as shown in "TIRES, WHEELS AND BALLAST" section.

Follow recommendations for proper ballasting.

◆ Driving the tractor on the road

1. Lock the 2 brake pedals together to help assure straight-line stops. Uneven braking at road speeds could cause the tractor to tip over.

[GST / Manual Transmission Type]

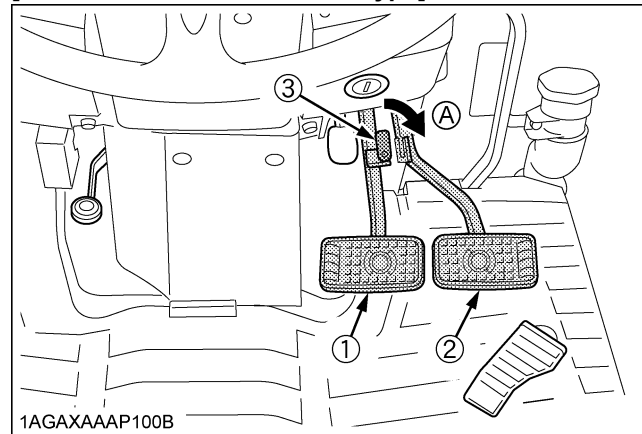

[HST Type]

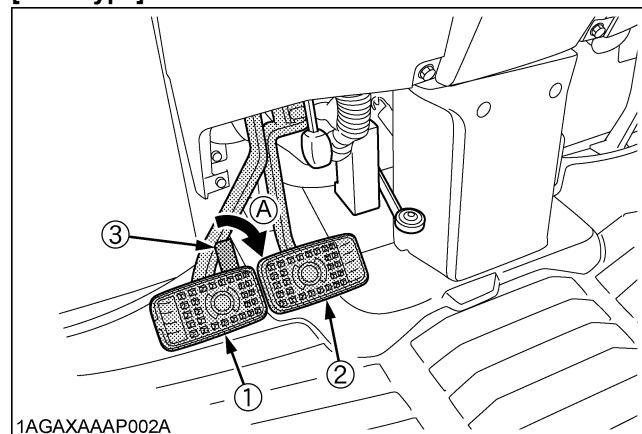

- (1) Brake Pedal (LH) (A) Whenever traveling on the road
 (2) Brake Pedal (RH)
 (3) Brake Pedal Lock

2. Check the front wheel engagement. The braking characteristics are different between 2 and 4-wheel drive. Be aware of the difference and use carefully.
3. Always slow the tractor down before turning. Turning at high speed may tip the tractor over.

▲-4 SAFE OPERATION

4. Make sure that the Slow Moving Vehicle (SMV) sign is clean and visible. Use hazard lights and turn signals as required.

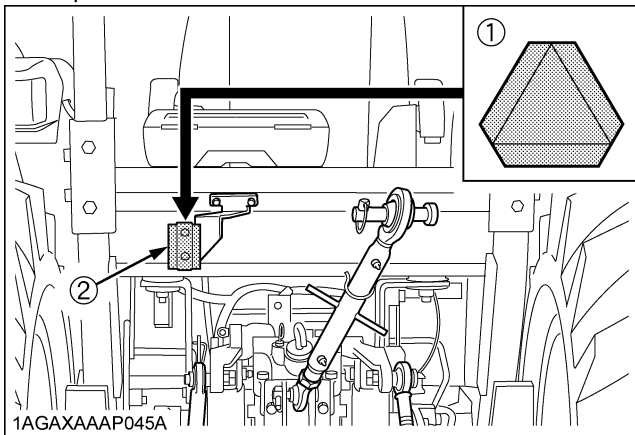

- (1) SMV emblem
- (2) Bracket

5. Observe all local traffic and safety regulations.
6. Turn the headlights on. Dim them when meeting another vehicle.
7. Drive at speeds that allow you to maintain control at all times.
8. Do not apply the differential lock while traveling at road speeds. The tractor may run out of control.
9. Avoid sudden motions of the steering wheel as they can lead to a dangerous loss of stability. The risk is especially great when the tractor is traveling at road speeds.
10. Keep the ROPS in the "UP" position and wear the seat belt when driving the tractor on the road. Otherwise, you will not be protected in the event of a tractor roll-over.
11. Do not operate an implement while the tractor is on the road. Lock the 3-point hitch in the raised position.
12. When towing other equipment, use a safety chain and place an SMV emblem on it as well.

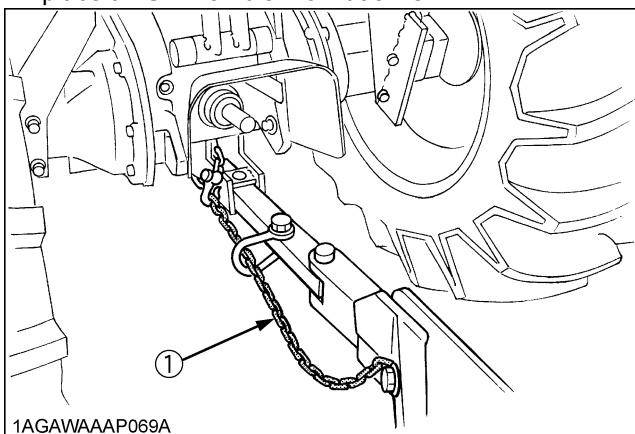

- (1) Safety chain

13. Set the implement lowering speed knob in the "LOCK" position to hold the implement in the raised position.

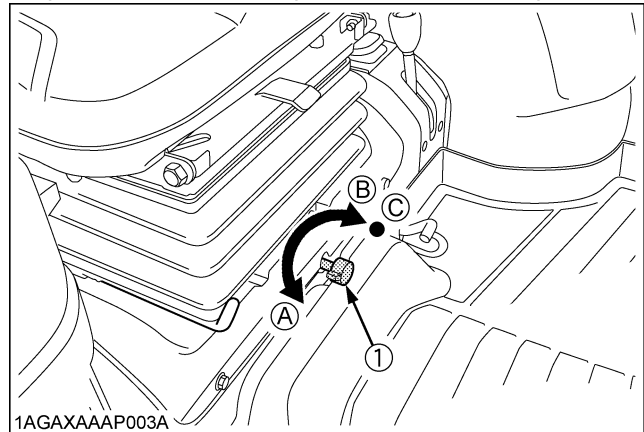

- (1) 3-point hitch lowering speed knob

- (A) "FAST"
- (B) "SLOW"
- (C) "LOCK"

3. PARKING THE TRACTOR

1. Disengage the PTO, lower all implements to the ground, place all control levers in their neutral positions, set the parking brake, stop the engine, remove the key from the ignition and lock the cab door (if equipped). Leaving transmission in gear with the engine stopped will not prevent tractor from rolling. (GST type, HST type)
2. Make sure that the tractor has come to a complete stop before dismounting.
3. Avoid parking on steep slopes, if at all possible park on a firm and level surface; if not, park across a slope and chock the wheels. Failure to comply with this warning may allow the tractor to move and could cause injury or death.

4. OPERATING THE PTO

1. Wait until all moving components have completely stopped before getting off the tractor, connecting, disconnecting, adjusting, cleaning, or servicing any PTO driven equipment.

- Keep the PTO shaft cover in place at all times. Replace the PTO shaft cap when the shaft is not in use.

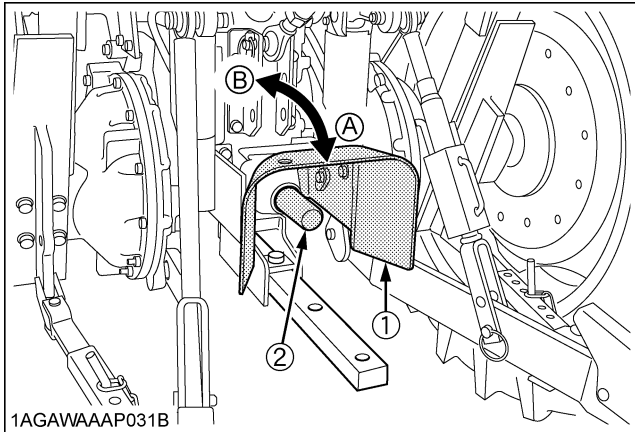

(1) PTO Shaft cover (A) "NORMAL POSITION"
(2) PTO Shaft cap (B) "RAISED POSITION"

- Before installing or using PTO driven equipment, read the manufacturer's manual and review the safety labels attached to the equipment.
- When operating stationary PTO driven equipment, always apply the tractor parking brake and place chocks behind and in front of the rear wheels. Stay clear of all rotating parts. Never step over rotating parts.

5. USING 3-POINT HITCH

- Use the 3-point hitch only with equipment designed for 3-point hitch usage.
- When using a 3-point hitch mounted implement, be sure to install the proper counterbalance weight on the front of the tractor.
- To avoid injury from separation: Do not extend lift rod beyond the groove on the threaded rod.

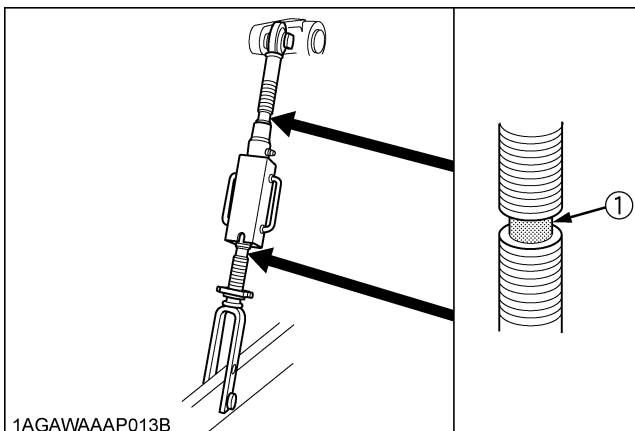

(1) Groove

6. SERVICING THE TRACTOR

Before servicing the tractor, park it on a firm, flat and level surface, set the parking brake, lower all implements to the ground, place the gear shift lever in neutral, stop the engine and remove the key.

- Allow the tractor time to cool off before working on or near the engine, muffler, radiator, etc.
- Do not remove radiator cap while coolant is hot. When cool, slowly rotate cap to the first stop and allow sufficient time for excess pressure to escape before removing the cap completely. If the tractor has a coolant recovery tank, add coolant or water to the tank, not the radiator. (See "Checking Coolant Level" in "DAILY CHECK" in "PERIODIC SERVICE" section.)
- Always stop the engine before refueling. Avoid spills and overfilling.
- Do not smoke when working around battery or when refueling. Keep all sparks and flames away from battery and fuel tank. The battery presents an explosive hazard, because it gives off hydrogen and oxygen especially when recharging.
- Before "jump starting" a dead battery, read and follow all of the instructions. (See "JUMP STARTING" in "OPERATING THE ENGINE" section.)
- Keep first aid kit and fire extinguisher handy at all times.
- Disconnect the battery's ground cable before working on or near electric components.
- To avoid the possibility of battery explosion, do not use or charge the refillable type battery if the fluid level is below the LOWER (lower limit level) mark. Check the fluid level regularly and add distilled water as required so that the fluid level is between the UPPER and LOWER levels.
- To avoid sparks from an accidental short circuit, always disconnect the battery's ground cable (-) first and reconnect it last.

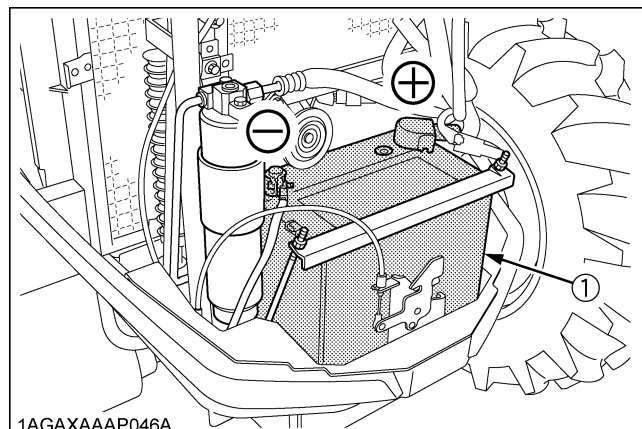

(1) Battery

- Do not attempt to mount a tire on a rim. This should be done by a qualified person with the proper equipment.

▲-6 SAFE OPERATION

11. Always maintain the correct tire pressure. Do not inflate tires above the recommended pressure shown in the operator's manual.

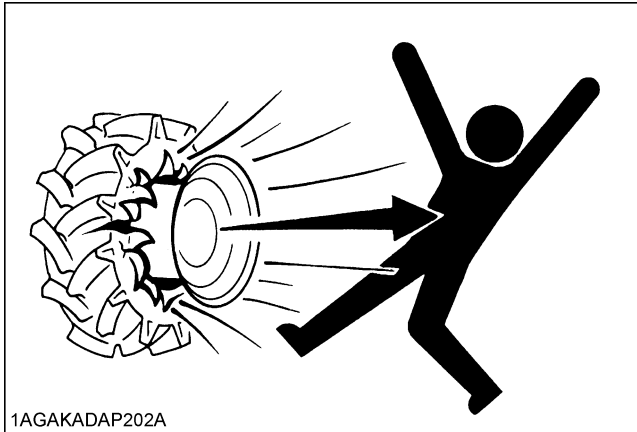

12. Securely support the tractor when either changing wheels or adjusting the wheel tread width.
13. Make sure that wheel bolts have been tightened to the specified torque.
14. Do not work under any hydraulically supported devices. They can settle, suddenly leak down, or be accidentally lowered. If it is necessary to work under tractor or any machine elements for servicing or adjustment, securely support them with stands or suitable blocking beforehand.
15. Escaping hydraulic fluid under pressure has sufficient force to penetrate skin, causing serious personal injury. Before disconnecting hydraulic lines, be sure to release all residual pressure. Before applying pressure to the hydraulic system, make sure that all connections are tight and that all lines, pipes, and hoses are free of damage.

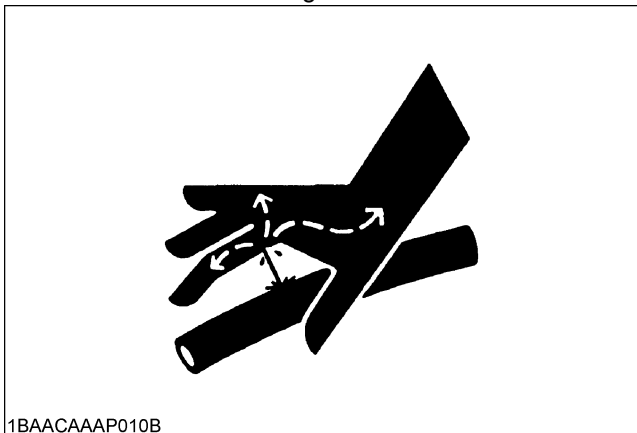

16. Fluid escaping from pinholes may be invisible. Do not use hands to search for suspected leaks; use a piece of cardboard or wood. Use of safety goggles or other eye protection is also highly recommended. If injured by escaping fluid, see a medical doctor at once. This fluid will produce gangrene or severe allergic reaction.

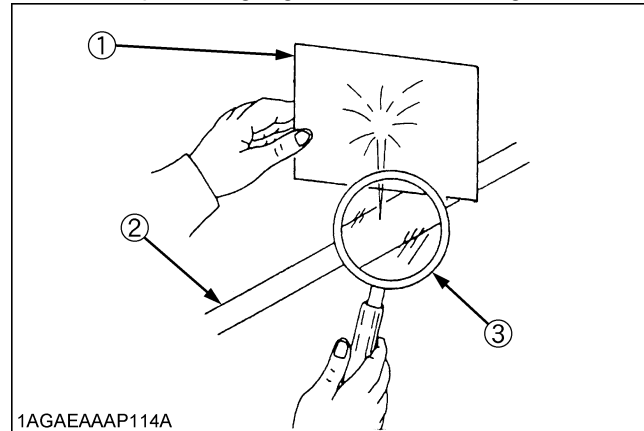

- (1) Cardboard
- (2) Hydraulic line
- (3) Magnifying glass

17. Do not open high-pressure fuel system.
High-pressure fluid remaining in fuel lines can cause serious injury. Do not disconnect nor attempt to repair fuel lines, sensors, or any other components between the high-pressure fuel pump and injectors on engines with high pressure common rail fuel system.
18. To avoid hazardous high voltage, turn the key switch to the OFF position if it is necessary to check to repair the computer, harness or connectors.
19. During Diesel Particulate Filter (hereinafter called DPF) regenerating operations, exhaust gases and exhaust filter components reach temperatures hot enough to burn people, or ignite or melt common materials.
20. Keep the tractor away from people, animals or structures which may be susceptible to harm or damage from hot exhaust gases.
21. To prevent fires, keep the DPF muffler and its surroundings clear of anything flammable and keep clean at all times.
22. During regeneration, white exhaust gas may be visible. Do not allow regeneration in a non-ventilated space.
23. During regeneration, do not leave the tractor.

7. DANGER, WARNING AND CAUTION LABELS

(1) Part No. TD170-4933-1 [HST type]

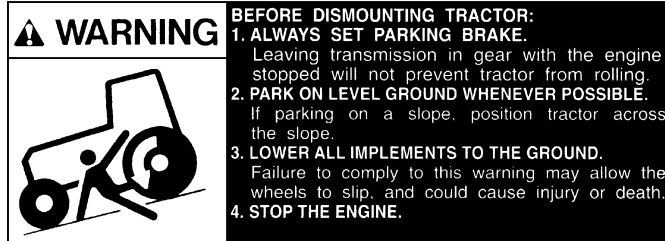

1AGAMAAAP3720

(2) Part No. TA040-4934-2
[Mid-PTO type]



1AGAMAAAP4880

(1) Part No. TA140-4992-1 [GST type]

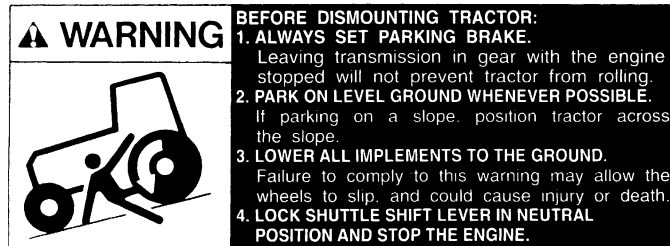

1AGAMAAAP3990

(3) Part No. TC420-4956-1

Diesel fuel only

No fire



1AGAIDHAP154E

(1) Part No. TA140-4933-1 [Manual Transmission type]

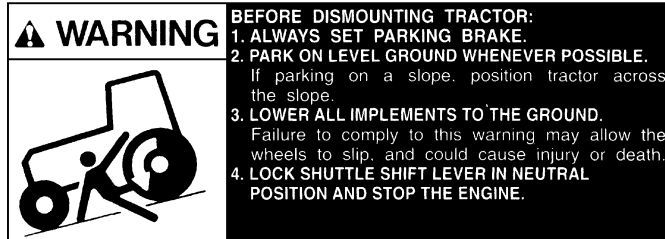

1AGAMAAAP4000

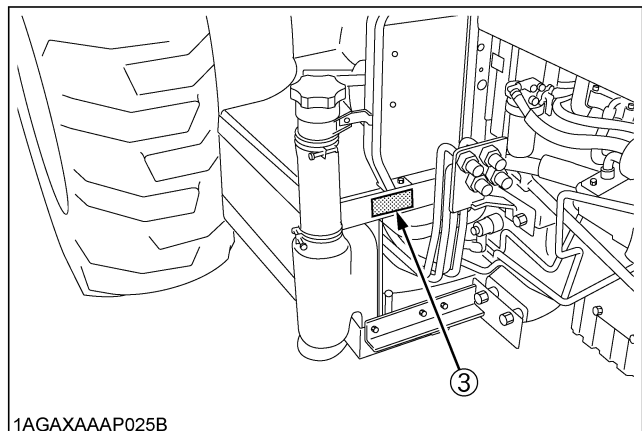
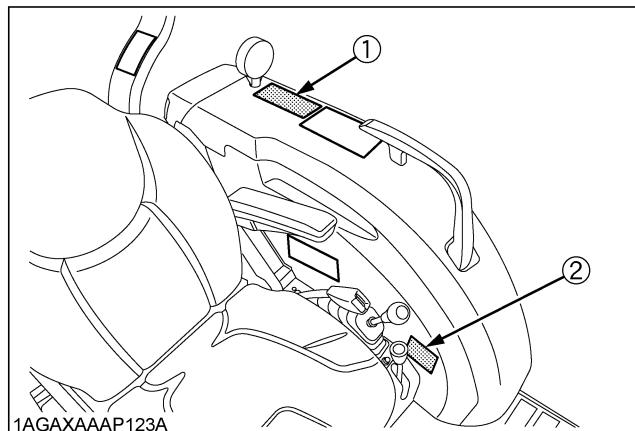

1AGAXAAP108A

(1) Part No. TD170-4935-1

<p>WARNING</p> <p>TO AVOID PERSONAL INJURY:</p> <ol style="list-style-type: none"> 1. Attach pulled or towed loads to the drawbar only. 2. Use the 3-point hitch only with equipment designed for 3-point hitch usage. 	<p>CAUTION</p> <p>TO AVOID INJURY FROM SEPARATION:</p> <p>Do not extend lift rod beyond the groove on the threaded rod.</p>
--	---

1AGAWAAP085A

(2) Part No. TA040-4959-3

	<p>WARNING</p> <p>TO AVOID PERSONAL INJURY.</p> <ol style="list-style-type: none"> 1. Keep PTO shield in place at all times. 2. Do not operate the PTO at speeds faster than the speed recommended by the implement manufacturer. 3. For trailing PTO-driven implements, set drawbar at towing position (see operator's manual).
--	---

1AGAMAAP3830

(3) Part No. TD060-3012-3

<p>FLAMMABLES</p>	<p>SHIELD EYES</p>	<p>KEEP OUT OF THE REACH OF CHILDREN</p>	<p>CAUTIOUS OF SULFURIC ACID</p>	<p>READ INSTRUCTION MANUAL CAREFULLY</p>	<p>EXPLOSIVE</p>
<p>DANGER</p> <ul style="list-style-type: none"> • DUE TO HYDROGEN GAS GENERATED FROM BATTERY, HANDLING WITHOUT CARE CAN CAUSE FIRE AND EXPLOSION • THIS 12V BATTERY IS ONLY FOR STARTING ENGINE. DO NOT APPLY THIS PRODUCT FOR OTHER USES. • CHARGE THIS BATTERY ONLY AT WELL VENTILATED PLACES, AND AVOID SHORTS OR SPARKS. • REFER TO THE INSTRUCTION MANUAL OF VEHICLE OR BATTERY BEFORE USING BOOSTER CABLE. • SULFURIC ACID MAY CAUSE BLINDNESS OR SEVERE BURN. IN CASE EYES, SKIN, CLOTHES OR ANY ARTICLES ARE STAINED WITH ACID, FLUSH OBJECTS IMMEDIATELY WITH WATER. IF ACID BEING SWALLOWED, DRINK PLENTY OF WATER PROMPTLY. IN CASE OF ACCIDENTAL CONTACT, CONSULT A DOCTOR IMMEDIATELY. • BATTERY FILLED WITH ACID (DO NOT TILT OR SPILL) • FLAMMABLE: DO NOT CHARGE NEAR FIRE OR SPARKS • DO NOT CHARGE RAPIDLY • DO NOT DISASSEMBLE THE BATTERY (SEALED TYPE) 					
<p>DANGER EXPLOSIVE GASES Cigarettes, flames or sparks could cause battery to explode. Always shield eyes and face from battery. Do not charge or use booster cables or adjust post connections without proper instruction and training.</p> <p>POISON CAUSES SEVERE BURNS Contains sulfuric acid. Avoid contact with skin, eyes or clothing. In event of accident flush with water and call a physician immediately.</p> <p>KEEP OUT OF REACH OF CHILDREN</p>					
<p>S.O.C INDICATOR</p> <p> OK CHARGE BATTERY REPLACE BATTERY </p>					
<p>PROPOSITION 65 WARNING BATTERY POSTS, TERMINALS, AND RELATED ACCESSORIES CONTAIN LEAD AND LEAD COMPOUNDS. CHEMICALS KNOWN TO THE STATE OF CALIFORNIA TO CAUSE CANCER AND REPRODUCTIVE HARM. WASH HANDS AFTER HANDLING.</p>					
<p>FITTING DATE</p> <p> <input type="radio"/>0 <input type="radio"/>1 <input type="radio"/>2 <input type="radio"/>3 <input type="radio"/>4 <input type="radio"/>5 <input type="radio"/>6 <input type="radio"/>7 <input type="radio"/>8 <input type="radio"/>9 YEAR <input type="radio"/>1 <input type="radio"/>2 <input type="radio"/>3 <input type="radio"/>4 <input type="radio"/>5 <input type="radio"/>6 <input type="radio"/>7 <input type="radio"/>8 <input type="radio"/>9 <input type="radio"/>10 <input type="radio"/>11 <input type="radio"/>12 MONTH </p>					
<p>80D26R 12V</p>		<p>582CCA (SAE) 70Ah(20HR)</p>		<p>550CCA (EN) RC 133(MIN)</p>	
<p>LEAD RECYCLE REFORM DK 85493</p>					

1AGASABAP108A

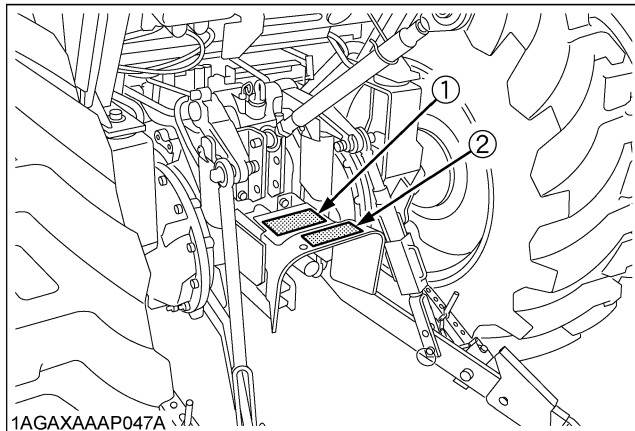

1AGAXAAP047A

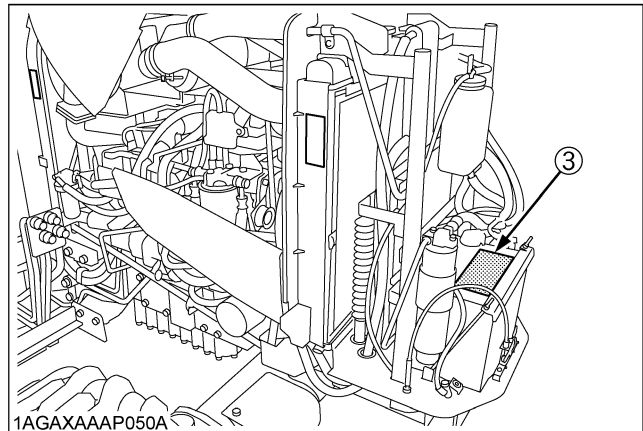

1AGAXAAP050A

1AGAXAAP109A

(1) Part No. 32751-4958-1

Do not get your hands close to engine fan and fan belt.



1AGAMAAAP3980

(2) Part No. TC030-4958-1

Do not touch hot surface like muffler, etc.

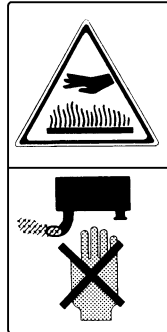

1AGAMAAAP3760

(3) Part No. 3C151-9861-1

⚠ CAUTION

TO AVOID PERSONAL INJURY:

When the Diesel Particulate Filter (DPF) is in the regenerating mode, the exhaust gas and the DPF muffler become hot. During regeneration, take into account that the muffler will be very hot and keep the machine away from other people, animals, plants, and flammable material. Also keep the area near the DPF muffler clean and away from flammable material.

1AGAIJHAP084A

(4) Part No. 3C581-9858-1

⚠ DANGER

TO AVOID POSSIBLE INJURY OR DEATH FROM A MACHINE RUNAWAY.

1. Do not start engine by shorting across starter terminals or bypassing the safety start switch. Machine may start in gear and move if normal starting circuitry is bypassed.
2. Start engine only from operator's seat with transmission and PTO OFF. Never start engine while standing on the ground.

1AGAMAAAP3810

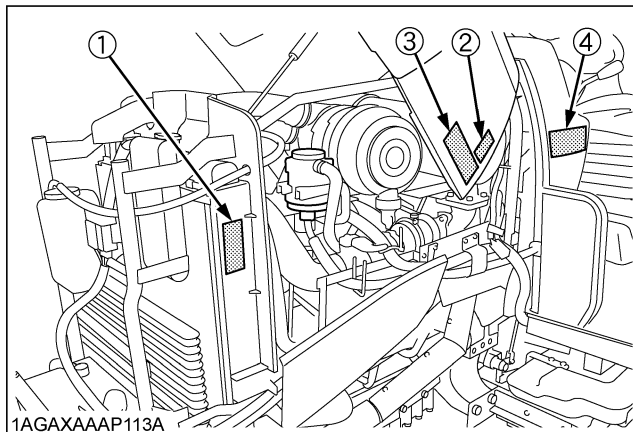

1AGAXAAP113A

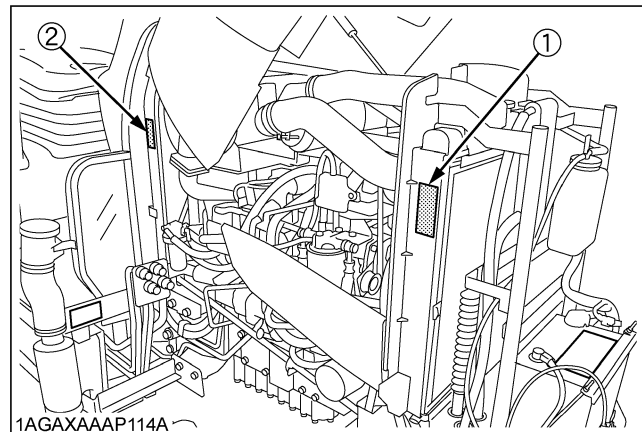

1AGAXAAP114A

1AGAXAAP110A

(1) Part No. 6C140-4746-1
[Foldable ROPS type]



▲ WARNING

TO AVOID PERSONAL INJURY:

Do not modify or repair a ROPS because welding, grinding, drilling or cutting any portion may weaken the structure.

1AGAMAAAP3870

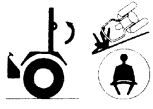
(3) Part No. TA240-9848-2
[Foldable ROPS type]

	▲ WARNING
	TO AVOID INJURY OR DEATH FROM ROLL-OVER:
	<ul style="list-style-type: none"> • Keep Roll-Over Protective Structures (ROPS) in the upright and locked position • Fasten SEAT BELT before operating
	THERE IS NO OPERATOR PROTECTION WHEN THE ROPS IS IN THE FOLDED POSITION:
	<ul style="list-style-type: none"> • Check the operating area and fold the ROPS only when absolutely necessary • Do not wear SEAT BELT if ROPS is folded • Raise and lock ROPS as soon as vertical clearance allows • Read ROPS related instructions and warnings

1AGAMAAAP3730

(2) Part No. TD060-4927-1
[Foldable ROPS type]

▲ CAUTION

TO AVOID INJURY WHEN RAISING OR FOLDING ROPS:

- Set parking brake and stop engine.
- Remove any obstruction that may prevent raising or folding of the ROPS.
- Do not allow any bystanders.
- Always perform function from a stable position at the rear of the tractor.
- Hold the top of the ROPS securely when raising or folding.
- Make sure all pins are installed and locked.

1AGAMAAAP4800

(4) Part No. TD170-4938-1

▲ CAUTION

TO AVOID PERSONAL INJURY:

1. Read and understand the operator's manual before operation.
2. Before starting the engine, make sure that everyone is at a safe distance from the tractor and that the PTO is OFF.
3. Do not allow passengers on the tractor at any time.
4. Before allowing other people to use the tractor, have them read the operator's manual.
5. Check the tightness of all nuts and bolts regularly.
6. Keep all shields in place and stay away from all moving parts.
7. Lock the two brake pedals together before driving on the road.
8. Slow down for turns, or rough roads, or when applying individual brakes.
9. On public roads use SMV emblem and hazard lights, if required by local traffic and safety regulations.
10. Pull only from the drawbar.
11. Before dismounting, lower the implement to the ground, set the parking brake, stop the engine and remove the key.
12. Securely support tractor and implements before working underneath.

1AGAMAOAP0800

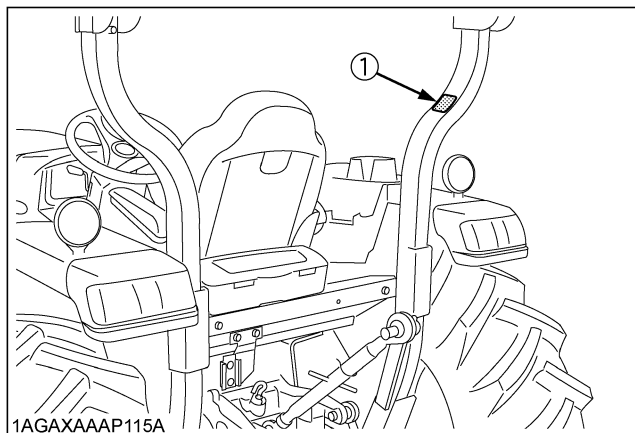

1AGAXAAP115A

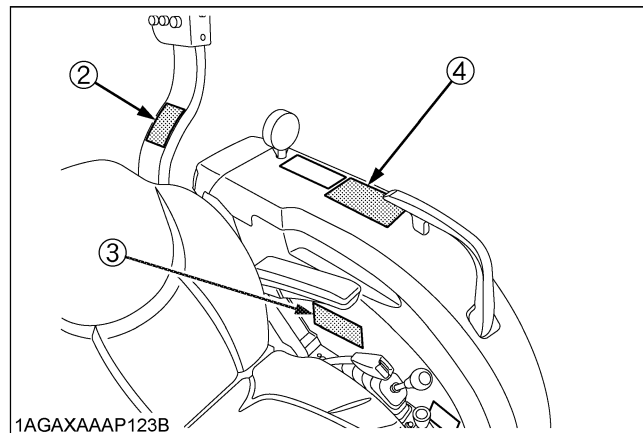

1AGAXAAP123B

1AGAXAAP112A

8. CARE OF DANGER, WARNING AND CAUTION LABELS

1. Keep danger, warning and caution labels clean and free from obstructing material.
2. Clean danger, warning and caution labels with soap and water, dry with a soft cloth.
3. Replace damaged or missing danger, warning and caution labels with new labels from your local KUBOTA Dealer.
4. If a component with danger, warning and caution label(s) affixed is replaced with new part, make sure new label(s) is (are) attached in the same location(s) as the replaced component.
5. Mount new danger, warning and caution labels by applying on a clean dry surface and pressing any bubbles to outside edge.

SERVICING OF TRACTOR

Your dealer is interested in your new tractor and has the desire to help you get the most value from it. After reading this manual thoroughly, you will find that you can do some of the regular maintenance yourself.

However, when in need of parts or major service, be sure to see your KUBOTA Dealer.

For service, contact the KUBOTA Dealership from which you purchased your tractor or your local KUBOTA Dealer.

When in need of parts, be prepared to give your dealer the tractor, CAB/ROPS and engine serial numbers.

Locate the serial numbers now and record them in the space provided.

	Type	Serial No.
Tractor		
CAB / ROPS		
Engine		
Date of Purchase		
Name of Dealer		
(To be filled in by purchaser)		

◆ **Warranty**

This tractor is warranted under the KUBOTA Limited Express Warranty, a copy of which may be obtained from your selling dealer. No warranty shall, however, apply if the tractor has not been handled according to the instruction given in the Operator's Manual even it is within the warranty period.

◆ **Scrapping the tractor and its procedure**

To put the tractor out of service, correctly follow the local rules and regulations of the country or territory where you scrap it. If you have questions, consult your local KUBOTA Dealer.

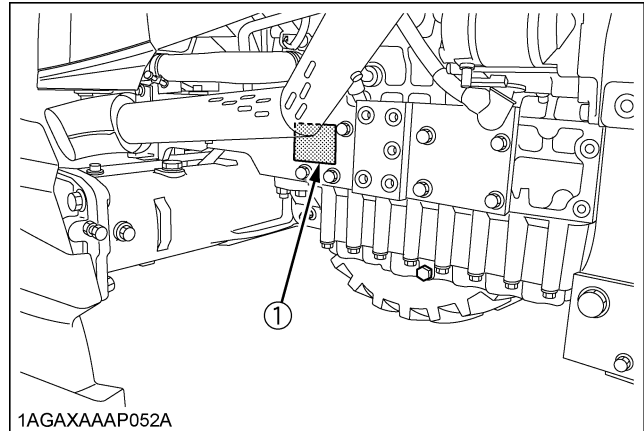

(1) Tractor identification plate

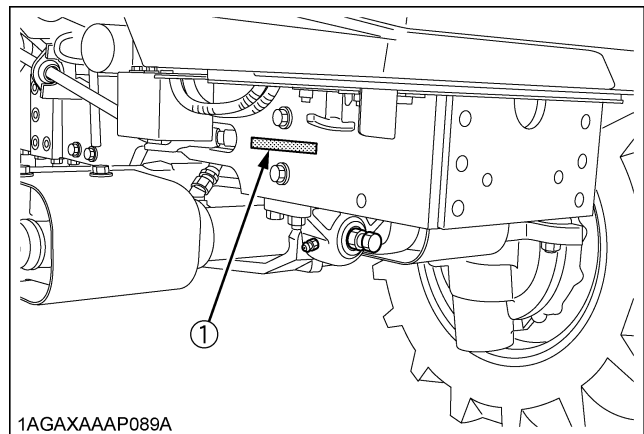

(1) Tractor serial number

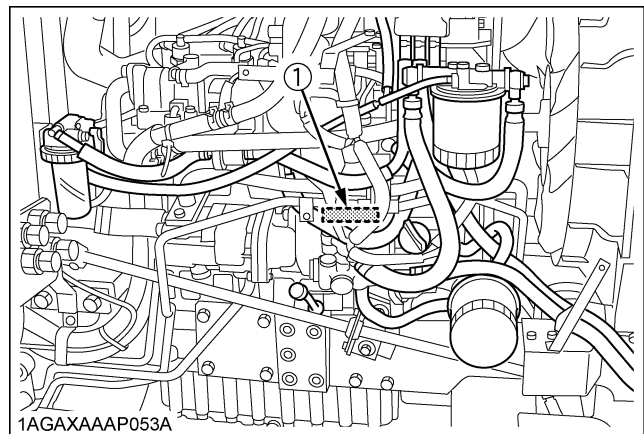

(1) Engine serial number

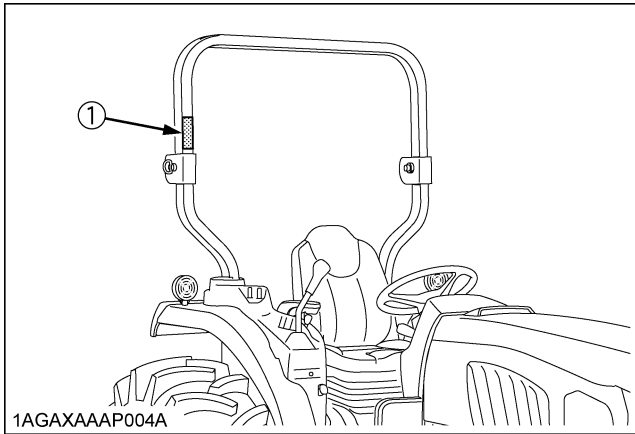

(1) ROPS identification plate (ROPS Serial No.)

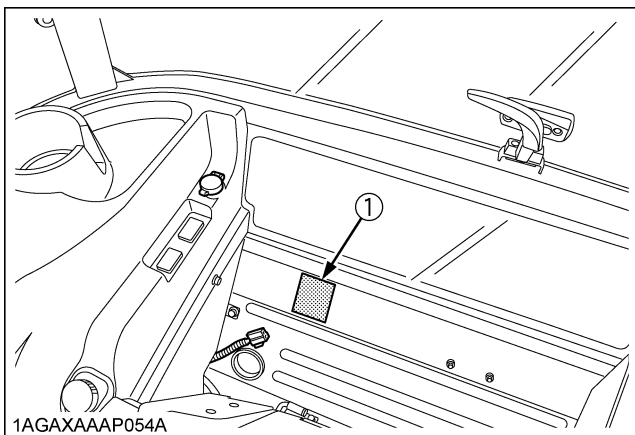

(1) CAB identification plate (CAB Serial No.)

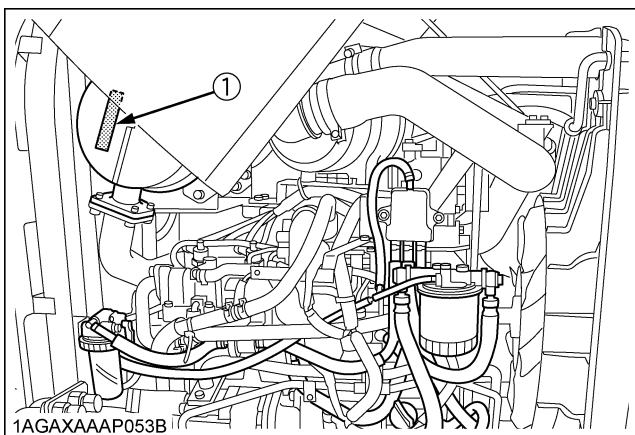

(1) Diesel Particulate Filter (DPF) serial number

SPECIFICATIONS

SPECIFICATION TABLE [HST Type]

Model		L3560	L4060	L4760	L5460	L6060	
		4WD					
Engine	Model	D1803-CR-E4	V2403-CR-E4		V2403-CR-TE4		
	Type	Direct injection vertical, water-cooled, 4-cycle diesel					
	Number of cylinders	3	4				
	Total displacement	L (cu. in.)	1.826 (111.4)	2.434 (148.5)			
	Bore and stroke	mm (in.)	87 x 102.4 (3.4 x 4.0)				
	Rated revolution	rpm	2600				
	Low idling revolution	rpm	800				
	Net power*	kW (HP)	26.1 (35.0)	29.8 (40.0)	35.1 (47.0)	40.3 (54.0)	44.8 (60.0)
	PTO power* (factory observed)	kW (HP)/rpm	20.9 (28.0)/2600	24.2 (32.5)/2600	29.5 (39.5)/2600	34.7 (46.5)/2600	39.5 (53.0)/2600
	Maximum torque	N-m (ft-lbs.)	114.1 (84.2)	133.5 (98.5)	157.4 (116.1)	182.6 (134.7)	195.6 (144.3)
	Battery capacity	12V, RC: 133 min, CCA: 582A					
Capacities	Fuel tank	L (U.S.gals.)	51 (13.5)				
	Engine crankcase (with filter)	L (U.S.qts.)	6.7 (7.1)	8.2 (8.7)		9.4 (9.9)	
	Engine coolant	L (U.S.qts.)	7.5 (7.9)		8.2 (8.7)		
	Transmission case	L (U.S.gals.)	42 (11.1)	43 (11.4)		45 (11.9)	
Dimensions	Overall length (without 3p)	mm (in.)	2920 (115.0)	3085 (121.5)		3210 (126.4)	
	Overall width (min. tread)	mm (in.)	1520 (59.8)	1690 (66.5)		1710 (67.3)	
	Overall height (with ROPS)	mm (in.)	2470 (97.2)	2480 (97.6)		2490 (98.0)	
	Wheel base	mm (in.)	1805 (71.1)	1895 (74.6)		1915 (75.4)	
	Min. ground clearance	mm (in.)	342 (13.5)	360 (14.2)		392 (15.4)	
	Tread	Front	mm (in.)	1155 (45.5)		1300 (51.2)	1340 (52.8)
		Rear	mm (in.)	1200 (47.2) 1300 (51.2) 1385 (54.5) 1480 (58.3)	1285 (50.6) 1435 (56.5) 1530 (60.2)		1325 (52.2) 1430 (56.3)
Weight (with ROPS)	kg (lbs.)	1655 (3649)	1700 (3748)	1720 (3792)	1825 (4023)		

4 SPECIFICATIONS

Model				L3560	L4060	L4760	L5460	L6060
				4WD				
Traveling system	Standard tire size	Front		7-16	8.3-16		9.5-16	
		Rear		12.4-24	14.9-24		14.9-26	
	Clutch			---				
	Steering			Hydrostatic power steering				
	Transmission			Hydrostatic transmission (3 speeds)				
	Braking system			Wet disk type				
	Min. turning radius (with brake)		m (feet)		2.7 (8.9)			2.8 (9.2)
Hydraulic unit	Hydraulic control system			Position control				
	Pump capacity		L (U.S.gals)/min.	30.4 (8.0)	35.6 (9.4)			
	3-point hitch			SAE category 1			SAE category 1, 2	
	Max. lift force	At lift points	kg (lbs.)	1700 (3750)	1750 (3860)			
		24 in. behind lift points	kg (lbs.)	1200 (2650)	1250 (2760)		1350 (2980)	
System pressure		MPa (kgf/cm ²)		17.7 (180)				
PTO	Rear PTO			SAE 1-3/8, 6 splines				
		PTO/Engine speed	rpm	540/2426	540/2476		540/2403	

NOTE : *Manufacturer's estimate

The company reserve the right to change the specifications without notice.

SPECIFICATION TABLE [GST type]

Model			L3560	L4060	L4760	L5060	
			4WD				
Engine	Model		D1803-CR-E4	V2403-CR-E4		V2403-CR-TE4	
	Type		Direct injection vertical, water-cooled, 4-cycle diesel				
	Number of cylinders		3	4			
	Total displacement	L (cu. in.)	1.826 (111.4)	2.434 (148.5)			
	Bore and stroke	mm (in.)	87 x 102.4 (3.4 x 4.0)				
	Rated revolution	rpm	2700				
	Low idling revolution	rpm	800				
	Net power*	kW (HP)	26.1 (35.0)	29.8 (40.0)	35.1 (47.0)	37.3 (50.0)	
	PTO power* (factory observed)	kW (HP)/ rpm	22.0 (29.5)/ 2700	25.4 (34.0)/ 2700	30.6 (41.0)/ 2700	32.8 (44.0)/ 2700	
	Maximum torque	N-m (ft-lbs.)	114.1 (84.2)	133.5 (98.5)	157.4 (116.1)	164.2 (121.1)	
	Battery capacity		12V, RC: 133 min, CCA: 582A				
Capacities	Fuel tank	L (U.S.gals.)	51 (13.5)				
	Engine crankcase (with filter)	L (U.S.qts.)	6.7 (7.1)	8.2 (8.7)		9.4 (9.9)	
	Engine coolant	L (U.S.qts.)	7.5 (7.9)		8.2 (8.7)		
	Transmission case	L (U.S.gals.)	42 (11.1)	43 (11.4)		45 (11.9)	
Dimensions	Overall length (without 3p)		mm (in.)	2920 (115.0)	3085 (121.5)		3210 (126.4)
	Overall width (min. tread)		mm (in.)	1520 (59.8)	1690 (66.5)		1710 (67.3)
	Overall height (with ROPS)		mm (in.)	2470 (97.2)	2480 (97.6)		2490 (98.0)
	Wheel base		mm (in.)	1805 (71.1)	1895 (74.6)		1915 (75.4)
	Min. ground clearance		mm (in.)	342 (13.5)	360 (14.2)		392 (15.4)
	Tread	Front	mm (in.)	1155 (45.5)		1300 (51.2)	
Rear		mm (in.)	1200 (47.2) 1300 (51.2) 1385 (54.5) 1480 (58.3)	1285 (50.6) 1435 (56.5) 1530 (60.2)		1325 (52.2) 1430 (56.3)	
Weight (with ROPS)		kg (lbs.)	1610 (3549)	1655 (3649)	1675 (3693)		1780 (3924)
Traveling system	Standard tire size	Front	7-16		8.3-16		9.5-16
		Rear	12.4-24		14.9-24		14.9-26
	Clutch		Dry type single stage				
	Steering		Hydrostatic power steering				
	Transmission		Glide shift transmission (12 forward and 8 reverse speeds)				
	Braking system		Wet disk type				
Min. turning radius (with brake)		m (feet)	2.7 (8.9)			2.8 (9.2)	

6 SPECIFICATIONS

Model				L3560	L4060	L4760	L5060
				4WD			
Hydraulic unit	Hydraulic control system			Position control			
	Pump capacity		L (U.S.gals)/ min.	31.5 (8.3)	37.0 (9.8)		
	3-point hitch			SAE category 1			SAE category 1, 2
	Max. lift force	At lift points	kg (lbs.)	1700 (3750)	1750 (3860)		
		24 in. behind lift points	kg (lbs.)	1200 (2650)	1250 (2760)		1350 (2980)
	System pressure		MPa (kgf/cm ²)	17.7 (180)			
PTO	Rear PTO			SAE 1-3/8, 6 splines			
		PTO/ Engine speed	rpm	540/2550			

NOTE : *Manufacturer's estimate

The company reserve the right to change the specifications without notice.

SPECIFICATION TABLE [Manual Transmission Type]

Model			L3560	L4060	
4WD					
Engine	Model		D1803-CR-E4	V2403-CR-E4	
	Type		Direct injection vertical, water-cooled, 4-cycle diesel		
	Number of cylinders		3	4	
	Total displacement	L (cu. in.)	1.826 (111.4)	2.434 (148.5)	
	Bore and stroke	mm (in.)	87 x 102.4 (3.4 x 4.0)		
	Rated revolution	rpm	2700		
	Low idling revolution	rpm	800		
	Net power*	kW (HP)	26.1 (35.0)	29.8 (40.0)	
	PTO power* (factory observed)	kW (HP)/rpm	22.0 (29.5) / 2700	25.4 (34.0) / 2700	
	Maximum torque	N-m (ft-lbs.)	114.1 (84.2)	133.5 (98.5)	
	Battery capacity		12V, RC: 133 min, CCA: 582A		
Capacities	Fuel tank	L (U.S.gals.)	51 (13.5)		
	Engine crankcase (with filter)	L (U.S.qts.)	6.7 (7.1)	8.2 (8.7)	
	Engine coolant	L (U.S.qts.)	7.5 (7.9)		
	Transmission case	L (U.S.gals.)	42 (11.1)	43 (11.4)	
Dimensions	Overall length (without 3p)		mm (in.)	2920 (115.0)	3085 (121.5)
	Overall width (min. tread)		mm (in.)	1520 (59.8)	1690 (66.5)
	Overall height (with ROPS)		mm (in.)	2470 (97.2)	2480 (97.6)
	Wheel base		mm (in.)	1805 (71.1)	1895 (74.6)
	Min. ground clearance		mm (in.)	342 (13.5)	360 (14.2)
	Tread	Front	mm (in.)	1155 (45.5)	
Rear		mm (in.)	1200 (47.2), 1300 (51.2), 1385 (54.5), 1480 (58.3)	1285 (50.6), 1435 (56.5), 1530 (60.2)	
Weight (with ROPS)		kg (lbs.)	1590 (3505)	1635 (3605)	
Traveling system	Standard tire size	Front	7-16	8.3-16	
		Rear	12.4-24	14.9-24	
	Clutch		Dry type single stage		
	Steering		Hydrostatic power steering		
	Transmission		8 forward and 8 reverse fully synchronized main and shuttle transmission		
	Braking system		Wet disk type		
Min. turning radius (with brake)		m (feet)	2.7 (8.9)		
Hydraulic unit	Hydraulic control system		Position control		
	Pump capacity	L (U.S.gals)/ min.	31.5 (8.3)	37.0 (9.8)	
	3-point hitch		SAE category 1		
	Max. lift force	At lift points	kg (lbs.)	1700 (3750)	1750 (3860)
		24 in. behind lift points	kg (lbs.)	1200 (2650)	1250 (2760)
System pressure		MPa (kgf/cm ²)	17.7 (180)		

8 SPECIFICATIONS

Model				L3560	L4060
				4WD	
PTO	Rear PTO	SAE 1-3/8, 6 splines			
		PTO/ Engine speed	rpm	540/2550	

NOTE : *Manufacturer's estimate

The company reserve the right to change the specifications without notice.

TRAVELING SPEEDS

■ HST Type

(At rated engine rpm)

Model			L3560		L4060, L4760		L5460, L6060	
Tire size (Rear)			12.4-24		14.9-24		14.9-26	
Speed control pedal	H-DS lever	Range gear shift lever	km/h	mph	km/h	mph	km/h	mph
Forward	L	L	3.4	2.1	3.4	2.1	3.4	2.1
		M	6.9	4.3	7.0	4.4	7.0	4.4
		H	15.9	9.9	16.2	10.1	16.2	10.1
	H	L	5.6	3.5	5.7	3.5	5.8	3.6
		M	11.5	7.1	11.7	7.3	11.8	7.3
		H	26.5	16.4	27.0	16.8	27.1	16.8
Reverse	L	L	3.0	1.9	3.1	1.9	3.1	1.9
		M	6.2	3.9	6.3	3.9	6.3	3.9
		H	14.3	8.9	14.5	9.0	14.6	9.1
	H	L	5.1	3.2	5.2	3.2	5.2	3.2
		M	10.3	6.4	10.5	6.5	10.6	6.6
		H	23.9	14.9	24.3	15.1	24.4	15.2

The company reserves the right to change the specifications without notice.

■ GST type

(At rated engine rpm)

Model			L3560		L4060, L4760		L5060	
Tire size (Rear)			12.4 - 24		14.9 - 24		14.9 - 26	
Shuttle shift lever	Creep gear shift lever	Main gear shift lever	km/h	mph	km/h	mph	km/h	mph
Forward	ON	1	0.18	0.11	0.17	0.11	0.17	0.11
		2	0.25	0.16	0.24	0.15	0.25	0.16
		3	0.34	0.21	0.32	0.20	0.33	0.21
		4	0.41	0.25	0.39	0.24	0.40	0.25
		5	0.51	0.32	0.47	0.29	0.49	0.30
		6	0.61	0.38	0.57	0.35	0.59	0.37
		7	0.73	0.45	0.71	0.44	0.73	0.45
		8	0.88	0.55	0.85	0.53	0.88	0.55
		9	1.03	0.64	1.00	0.62	1.03	0.64
		10	1.24	0.77	1.20	0.75	1.24	0.77
		11	2.02	1.26	1.95	1.21	2.01	1.25
		12	2.98	1.85	2.88	1.79	2.97	1.85
	OFF	1	1.6	1.0	1.5	0.9	1.5	1.0
		2	2.3	1.4	2.1	1.3	2.2	1.4
		3	3.1	1.9	2.9	1.8	3.0	1.8
		4	3.7	2.3	3.5	2.2	3.6	2.2
		5	4.5	2.8	4.2	2.6	4.4	2.7
		6	5.4	3.4	5.1	3.2	5.3	3.3
		7	6.5	4.0	6.3	3.9	6.5	4.1
		8	7.8	4.8	7.6	4.7	7.8	4.9
		9	9.2	5.7	8.9	5.5	9.2	5.7
		10	11.1	6.9	10.7	6.6	11.0	6.9
		11	18.0	11.2	17.4	10.8	17.9	11.2
		12	26.6	16.5	25.7	16.0	26.5	16.6
Reverse	ON	1	0.17	0.11	0.16	0.10	0.17	0.11
		2	0.24	0.15	0.23	0.14	0.23	0.14
		3	0.39	0.24	0.37	0.23	0.38	0.24
		4	0.58	0.36	0.55	0.34	0.56	0.35
		5	0.84	0.52	0.81	0.50	0.84	0.52
		6	1.19	0.74	1.15	0.71	1.18	0.73
		7	1.93	1.20	1.86	1.16	1.92	1.19
		8	2.85	1.77	2.75	1.71	2.84	1.76
	OFF	1	1.5	0.9	1.4	0.9	1.5	0.9
		2	2.2	1.4	2.0	1.2	2.1	1.3
		3	3.5	2.2	3.3	2.1	3.4	2.1
		4	5.2	3.2	4.9	3.0	5.0	3.1
		5	7.5	4.7	7.2	4.5	7.5	4.7
		6	10.6	6.6	10.2	6.3	10.5	6.6
		7	17.2	10.7	16.6	10.3	17.1	10.7
		8	25.4	15.8	24.5	15.2	25.3	15.8

The company reserves the right to change the specifications without notice.

■ Manual Transmission Type

(At rated engine rpm)

Model				L3560		L4060	
Tire size (Rear)				12.4 - 24		14.9 - 24	
Shuttle shift lever	Creep gear shift lever	Range gear shift lever	Main gear shift lever	km/h	mph	km/h	mph
Forward	ON	Low	1	0.18	0.11	0.17	0.11
			2	0.25	0.16	0.24	0.15
			3	0.41	0.25	0.39	0.24
			4	0.61	0.38	0.57	0.35
		High	1	0.88	0.55	0.85	0.53
			2	1.24	0.77	1.20	0.75
			3	2.02	1.26	1.95	1.21
			4	2.98	1.85	2.88	1.79
	OFF	Low	1	1.6	1.0	1.5	0.9
			2	2.3	1.4	2.1	1.3
			3	3.7	2.3	3.5	2.2
			4	5.4	3.4	5.1	3.2
		High	1	7.8	4.8	7.6	4.7
			2	11.1	6.9	10.7	6.6
			3	18.0	11.2	17.4	10.8
			4	26.6	16.5	25.7	16.0
Reverse	ON	Low	1	0.17	0.11	0.16	0.10
			2	0.24	0.15	0.23	0.14
			3	0.39	0.24	0.37	0.23
			4	0.58	0.36	0.55	0.34
		High	1	0.84	0.52	0.81	0.50
			2	1.19	0.74	1.15	0.71
			3	1.93	1.20	1.86	1.16
			4	2.85	1.77	2.75	1.71
	OFF	Low	1	1.5	0.9	1.4	0.9
			2	2.2	1.4	2.0	1.2
			3	3.5	2.2	3.3	2.1
			4	5.2	3.2	4.9	3.0
		High	1	7.5	4.7	7.2	4.5
			2	10.6	6.6	10.2	6.3
			3	17.2	10.7	16.6	10.3
			4	25.4	15.8	24.5	15.2

The company reserves the right to change the specifications without notice.

IMPLEMENT LIMITATIONS

The KUBOTA Tractor has been thoroughly tested for proper performance with implements sold or approved by KUBOTA. Use with implements which are not sold or approved by KUBOTA and which exceed the maximum specifications listed below, or which are otherwise unfit for use with the KUBOTA Tractor may result in malfunctions or failures of the tractor, damage to other property and injury to the operator or others. [Any malfunctions or failures of the tractor resulting from use with improper implements are not covered by the warranty.]

	Tread (max.width) with farm tires		Lower link end max. lifting capacity W0
	Front	Rear	
L3560	1155 mm (45.5 in.)	1480 mm (58.3 in.)	1700 kg (3750 lbs.)
L4060		1530 mm (60.2 in.)	
L4760	1300 mm (51.2 in.)		1750 kg (3860 lbs.)
L5060, L5460, L6060	1340 mm (52.8 in.)		

Actual figures			
	Implement weight W1 and / or size	Max. Drawbar Load W2	Trailer loading weight W3 Max. capacity
L3560	As in the following list (Shown on the next page)	650 kg (1430 lbs.)	2000 kg (4400 lbs.)
L4060			2500 kg (5500 lbs.)
L4760, L5060 L5460, L6060			3000 kg (6600 lbs.)

Lower link end max, hydraulic lifting capacity ...W0
 Implement weight.....The implement's weight which can be put on the lower link: W1
 Max. drawbar load.....W2
 Trailer loading weightThe max. loading weight for trailer (without trailer's weight) : W3

1AGAIAZAP121B

NOTE :

- Implement size may vary depending on soil operating conditions.
- Strictly follow the instructions outlined in the operator's manual of the mounted or trailed machinery or trailer, and do not operate the combination tractor - machine or tractor - trailer unless all instructions have been followed
- Forestry Application
 Following hazards exist;
 - (a) toppling trees, primarily in case a rear-mounted tree grab-crane is mounted at the rear of the tractor;
 - (b) penetrating objects in the operator's enclosure, primarily in case a winch is mounted at the rear of the tractor.
 Optional equipments such as OPS (Operator Protective Structure), FOPS (Falling Object Protective Structure), etc. to deal with these hazards and other related hazards are not available for this tractor. Without such optional equipment use is limited to tractor specific applications like transport and stationary work.

No.	Implement	Remarks		L3560	L4060	L4760	L5060, L5460, L6060	
1	Trailer	Max. load capacity	kg (lbs.)	2000 (4400)	2500 (5500)	3000 (6600)		
		Max. drawbar load	kg (lbs.)	650 (1430)				
2	Mower	Rotary-Cutter	Max. cutting width	mm (in.)	1829 (72)		2134 (84)	
			Max. weight	kg (lbs.)	350 (770)	420 (926)		480 (1058)
		Flail Mower	Max. cutting width	mm (in.)	1524 (60)		1829 (72)	
			Max. weight	kg (lbs.)	400 (880)		500 (1100)	
		Sickle Bar	Max. cutting width	mm (in.)	2134 (84)			
			Max. weight	kg (lbs.)	500 (1100)			
3	Sprayer	Rear mounted	Max. tank capacity	L (gal.)	300 (80)	400 (106)		500 (132)
		Pull type	Max. tank capacity	L (gal.)	1000 (264)	1200 (317)		2000 (528)
4	Rotary Tiller	Max. tilling width	mm (in.)	1524 (60)			1829 (72)	
5	Bottom Plow	Max. size	Max. size	12 in. x 2 16 in. x 1	14 in. x 2		16 in. x 2	
6	Disk harrow: Pull type	Max. harrowing width	mm (in.)	1829 (72)	1981 (78)		2134 (84)	
		Max. weight	kg (lbs.)	350 (770)	400 (880)			
7	Chisel Plow	Max. width	mm (in.)	1829 (72)				
		Max. weight	kg (lbs.)	350 (770)				
8	Broad Caster	Max. tank capacity	L (gal.)	250 (66)	300 (80)			
		Max. weight	kg (lbs.)	100 (220)				
9	Manure Spreader	Max. capacity	kg (lbs.)	1500 (3300)	2000 (4400)			
10	Cultivator	Max. width	mm (in.)	1829 (72)	2134 (84)		2438 (96)	
		Number of rows	Number of rows	1	2		4	
		Max. weight	kg (lbs.)	350 (770)	400 (880)			
11	Front Blade	Max. cutting width	mm (in.)	1829 (72)		2134 (84)		
		Max. oil pressure	kgf/cm ² (psi)	175 (2490)				
		Sub frame	Necessary					
12	Rear Blade	Max. cutting width	mm (in.)	1829 (72)				
		Max. oil pressure	kgf/cm ² (psi)	175 (2490)				
13	Front-end Loader	Max. lifting capacity	kg (lbs.)	720 (1590)		850 (1880)		
		Max. oil pressure	kgf/cm ² (psi)	180 (2560)				
		Sub frame	Necessary					
14	Box Blade	Max. cutting width	mm (in.)	1651 (65)		1829 (72)		
		Max. weight	kg (lbs.)	400 (880)		470 (1040)		
15	Back Hoe	Max. digging depth	mm (in.)	2286 (90)				
		Max. weight	kg (lbs.)	450 (990)				
		Sub frame	Necessary					
16	Snow Blade	Max. width	mm (in.)	1829 (72)		2134 (84)		
		Max. weight	kg (lbs.)	350 (770)		400 (880)		
17	Snow Blower	Max. working width	mm (in.)	1702 (67)		1829 (72)		
		Max. weight	kg (lbs.)	280 (620)		330 (730)		

NOTE :

- Implement size may vary depending on soil operating conditions.

INSTRUMENT PANEL AND CONTROLS

■ Instrument Panel, Switches and Hand Controls

◆ HST Type

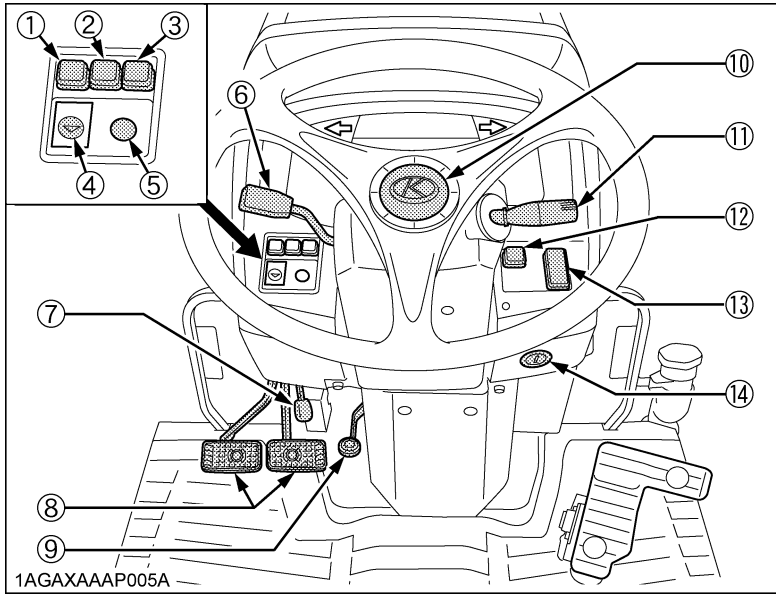

ILLUSTRATED CONTENTS

(1) DPF INHIBIT switch	20
(2) Parked regeneration switch	20
(3) Hazard light switch	39
(4) Display mode button	59
(5) ATA switch	51
(6) H-DS lever	44
(7) Parking brake lever	27, 49, 64
(8) Brake pedal	41
(9) Tilt pedal	38
(10) Horn button (if equipped)	39
(11) Turn signal / Head light switch	39
(12) Side work light switch	40
(13) Cruise control switch	50
(14) Key switch	27

◆ GST / Manual Transmission Type

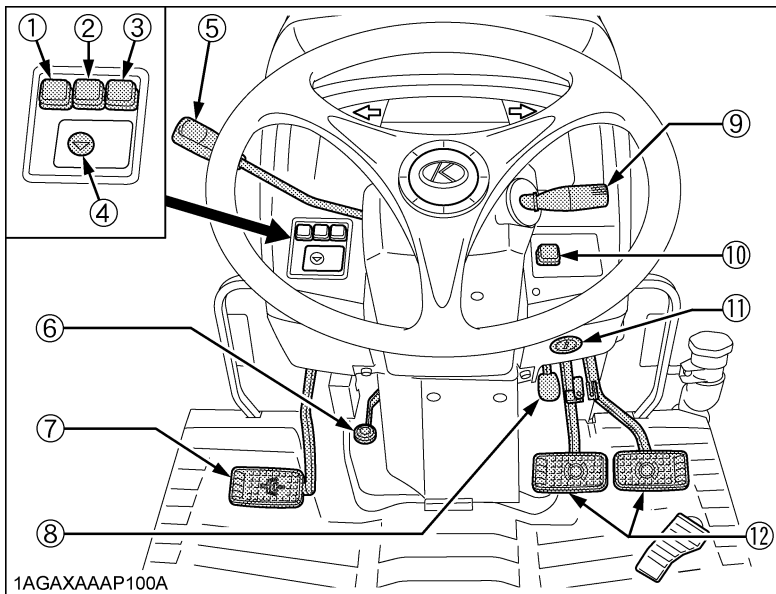

ILLUSTRATED CONTENTS

(1) DPF INHIBIT switch	20
(2) Parked regeneration switch	20
(3) Hazard light switch	39
(4) Display mode button	59
(5) Shuttle shift lever [GST Type] Synchro-shuttle shift lever [Manual Transmission Type]	52, 56
(6) Tilt pedal	38
(7) Clutch pedal	42
(8) Parking brake lever	27, 55, 58, 64
(9) Turn signal / Head light switch	39
(10) Side work light switch	40
(11) Key switch	27
(12) Brake pedal	41

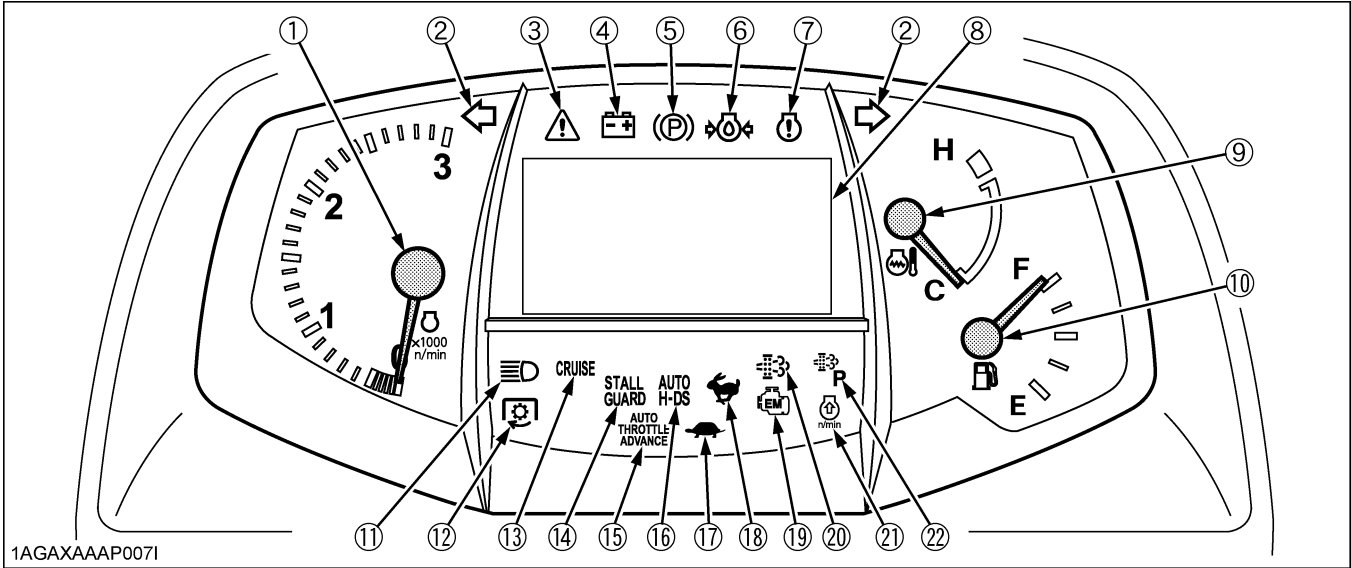

ILLUSTRATED CONTENTS





ILLUSTRATED CONTENTS

(1) Tachometer 64
 (2) Turn signal / hazard indicator 39
 (3) Master system warning indicator 63
 (4) Electrical charge warning indicator 63
 (5) Parking brake warning indicator 27
 (6) Engine oil pressure warning indicator 63
 (7) Engine warning indicator 63
 (8) IntelliPanel(TM) display 59
 (9) Coolant temperature gauge 64
 (10) Fuel gauge 63
 (11) High beam indicator 39

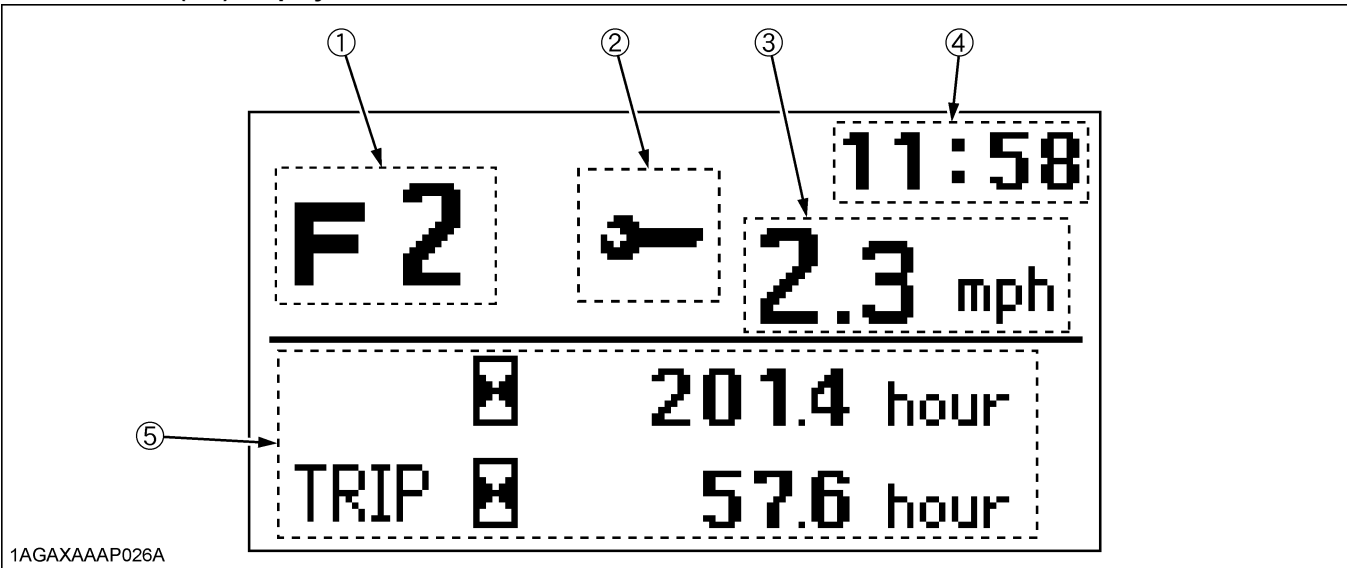
(12) PTO indicator 69
 (13) Cruise control indicator [HST Type] 50
 (14) Stall guard indicator [HST Type] 45
 (15) ATA indicator [HST Type] 51
 (16) Auto H-DS indicator [HST Type] 45
 (17) H-DS Low speed range indicator [HST Type] 44
 (18) H-DS High speed range indicator [HST Type] 44
 (19) Emission indicator 63
 (20) Regeneration indicator 20
 (21) Engine RPM increase indicator 20
 (22) Parked regeneration indicator 20

◆ IntelliPanel(TM) Display



No.	Message	Description	Reference page
(1)	"L", "H", "M" or "N"	[HST Type] Display the position of the range gear shift that was selected with the Range gear shift lever.	48
	"F1" to "F12" or "R1" to "R12" or "N"	[GST Type] "F" is displayed when forward operation is selected with the shuttle lever. "R" is displayed when reverse operation is selected. Displays the number of the gear shift ratios that was selected with the main gear shift lever. "N" is displayed when the lever is in the neutral position.	52 53
	"F", "R" or "N"	[Manual Transmission Type] "F" is displayed when forward operation is selected with the shuttle lever. "R" is displayed when reverse operation is selected. "N" is displayed when the lever is in the neutral position.	56
(2)	 1AGAXAAP096A	Appears when the time for an engine oil change has come. Change the engine oil with fresh one.	61, 62 103
	 1AGAXAAP097A	Stays displayed for 3 seconds or so after the engine has got started. Buckle up the seat belt.	38
	 1AGAXAAP098A	Stays displayed while the cooling water temperature is too low and the glow plug is being activated. Wait until this symbol disappears and get the engine started.	32
	 1AGAXAAP099A	Appears when the fuel has become less than 6 L (1.5 U.S.gals.) or so. Refuel as soon as possible. If the fuel tank becomes empty, air will enter the fuel system, thereby requiring a bleeding.	63
(3)	0.1 to 34	Displays the travel speed. (The actual speed is different from the displayed one if the tires slip in towing or other jobs.)	---
(4)	0:00 to 11:59	Displays the clock. When (— — : — —) is displayed, make the time setting. Nothing is displayed if this is disabled.	60
(5)	Lower IntelliPanel(TM) display	The hour meter, trip meter, mileage, PTO rpm, HST setting, PM volume status, time elapsed since the previous engine oil change and other data can be displayed.	59

■ Foot and Hand Controls

◆ HST Type

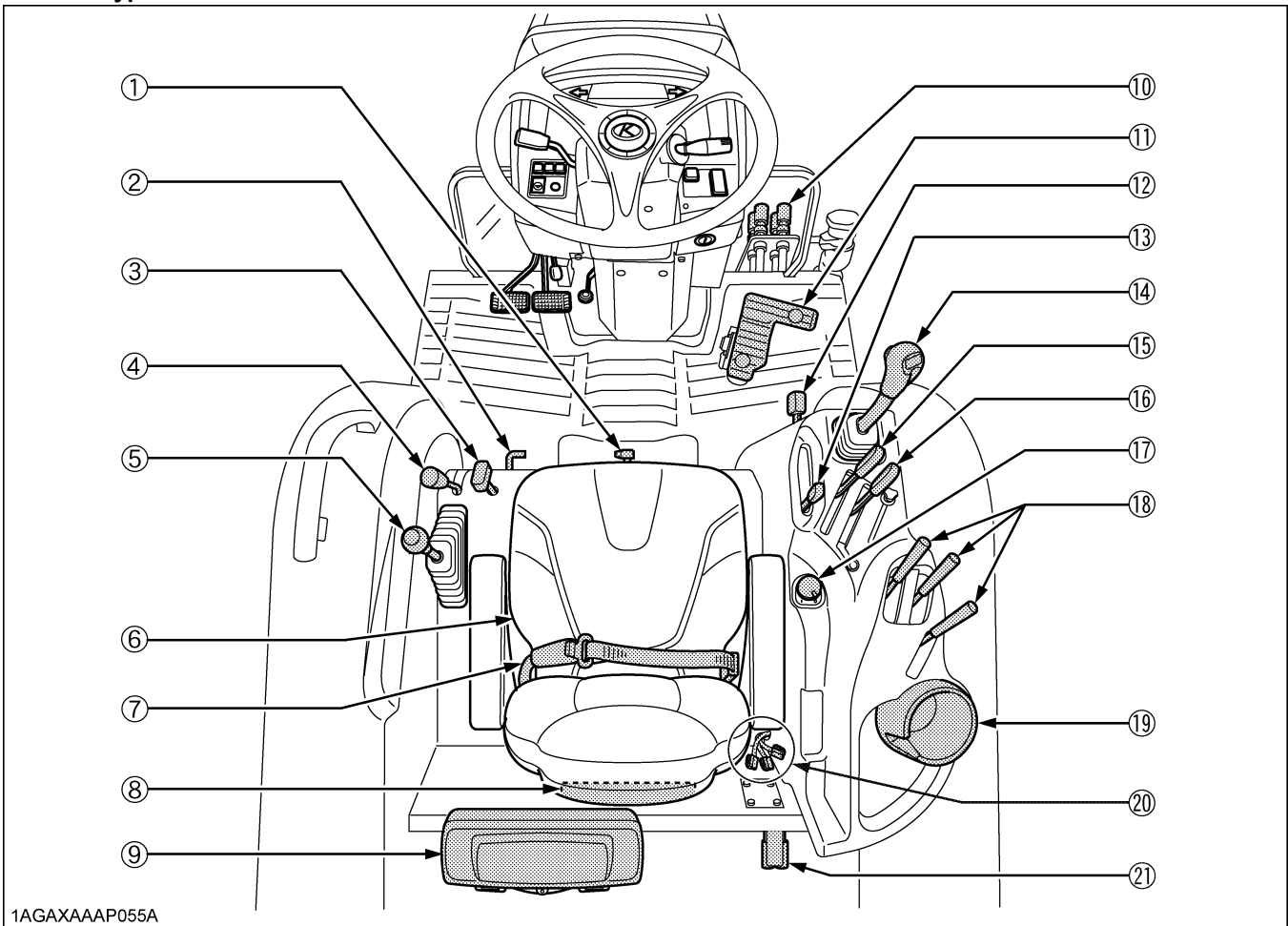

1AGAXAAP055A

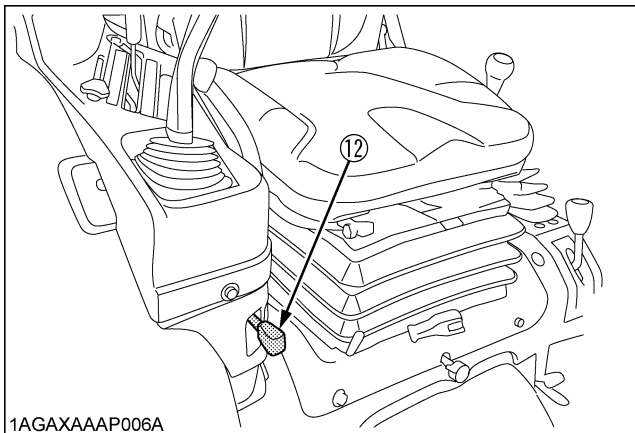

1AGAXAAP006A

ILLUSTRATED CONTENTS

(6) Operator's seat	37
(7) Seat belt	38
(8) Glove box	38
(9) Tool box	---
(10) Loader / Remote control valve coupler	76
(11) Speed control pedal	49
(12) Lock lever	78
(13) Hand throttle lever	27
(14) Loader / Remote control valve lever	77
(15) Draft control lever (if equipped)	75
(16) Position control lever	75
(17) PTO clutch control switch	67
(18) Remote control valve lever (if equipped)	78
(19) Cup holder	---
(20) Electrical outlet	66
(21) Remote control valve coupler (if equipped)	79

ILLUSTRATED CONTENTS

(1) 3-Point hitch lowering speed knob	76
(2) Differential lock pedal	65
(3) Mid-PTO lever (if equipped)	68
(4) Front wheel drive lever	48
(5) Range gear shift lever (L-M-H)	48

◆ GST / Manual Transmission Type

[GST Type]

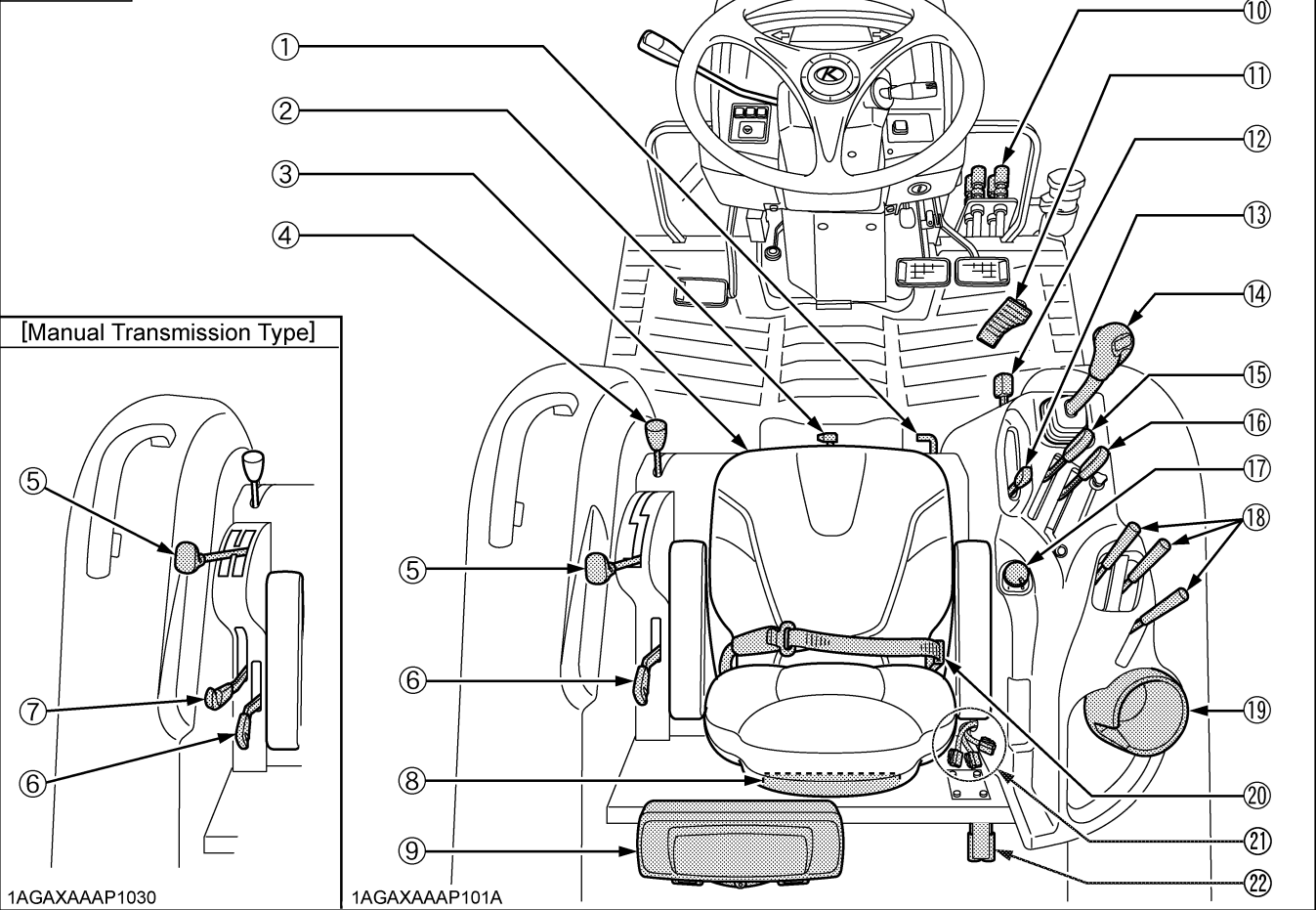

1AGAXAAP1030

1AGAXAAP101A

[Manual Transmission Type]

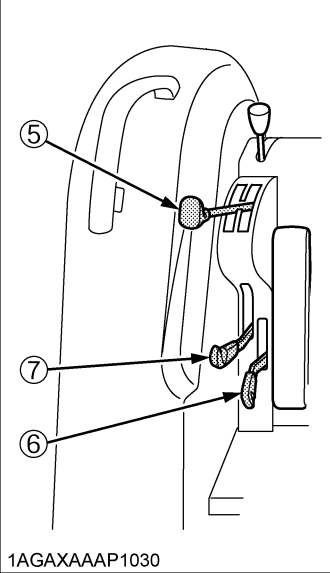

1AGAXAAP1030

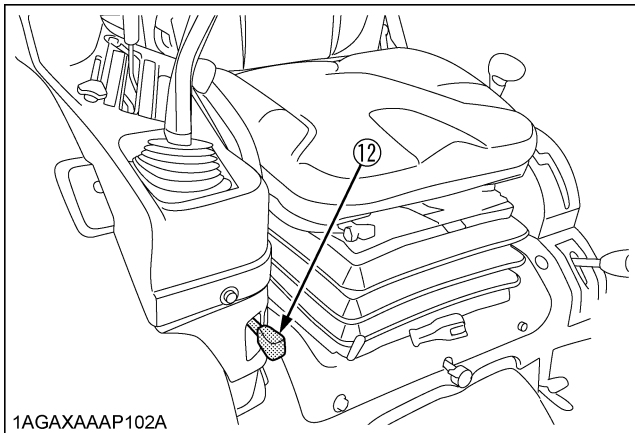

1AGAXAAP102A

ILLUSTRATED CONTENTS

(7) Range gear shift lever (Hi-Lo) [Manual Transmission Type]	56
(8) Glove box	38
(9) Tool box	---
(10) Loader / Remote control valve coupler	76
(11) Foot throttle	27
(12) Lock lever	78
(13) Hand throttle lever	27
(14) Loader / Remote control valve lever	77
(15) Draft control lever (if equipped)	75
(16) Position control lever	75
(17) PTO clutch control switch	67
(18) Remote control valve lever (if equipped)	78
(19) Cup holder	---
(20) Seat belt	38
(21) Electrical outlet	66
(22) Remote control valve coupler (if equipped)	79

ILLUSTRATED CONTENTS

(1) Differential lock pedal	65
(2) 3-Point hitch lowering speed knob	76
(3) Operator's seat	37
(4) Front wheel drive lever	54, 57
(5) Main gear shift lever	53, 56
(6) Creep gear shift lever (if equipped)	54, 57

PRE-OPERATION CHECK

DAILY CHECK

To prevent trouble from occurring, it is important to know the condition of the tractor well. Check it before starting.



WARNING

To avoid personal injury or death:

- **Be sure to check and service the tractor on a level surface with the engine shut off and the parking brake "ON" and implement lowered to the ground.**

Check item

- Walk around inspection
- Check engine oil level
- Check transmission oil level
- Check coolant level
- Clean grill and radiator screen
- Clean oil cooler [HST model]
- Check DPF muffler
- Check air cleaner dust indicator
(When used in a dusty place)
- Check brake pedal [HST model]
- Check brake and clutch pedal
[GST / Manual Transmission model]
- Check indicators, gauges and meter
- Check lights
- Check seat belt and ROPS
- Check movable parts
- Refuel
(See "DAILY CHECK" in "PERIODIC SERVICE" section.)
- Care of danger, warning and caution labels
(See "DANGER, WARNING AND CAUTION LABELS" in "SAFE OPERATION" section.)

OPERATING THE ENGINE



WARNING

To avoid personal injury or death:

- Read and understand "Safe Operation" in the front of this manual.
- Read and understand the danger, warning and caution labels located on the tractor.
- To avoid the danger of exhaust fume poisoning, do not operate the engine in a closed building without proper ventilation.
- Never start engine while standing on ground. Start engine only from operator's seat.
- Make it a rule to set all shift levers to the "NEUTRAL" positions and to place PTO clutch control switch in "OFF" position before starting the engine.

IMPORTANT :

- Do not use starting fluid or ether.
- To protect the battery and the starter, make sure that the starter is not continuously turned for more than 10 seconds.

EXHAUST AFTERTREATMENT DEVICES



WARNING

To avoid personal injury or death:

- During Diesel Particulate Filter (DPF) regenerating operations, exhaust gases and exhaust filter components reach temperatures hot enough to burn people, or ignite or melt common materials.
- Keep tractor away from people, animals or structures which may be susceptible to harm or damage from hot exhaust gases.
- During regeneration, white exhaust gases may be visible. Do not allow regeneration in a non ventilated garage or confined area.
- During regeneration, do not leave the tractor.

■ Diesel Particulate Filter (DPF) Muffler

This tractor is equipped with an engine with a DPF (Diesel Particulate Filter) muffler which serves to reduce hydrocarbons, carbon monoxide and other gases, all of which are contained in diesel engine emissions, to harmless carbon dioxide and water. The DPF also traps PM (particulate matter).

Please handle exhaust aftertreatment devices correctly and in an environmentally responsible manner.

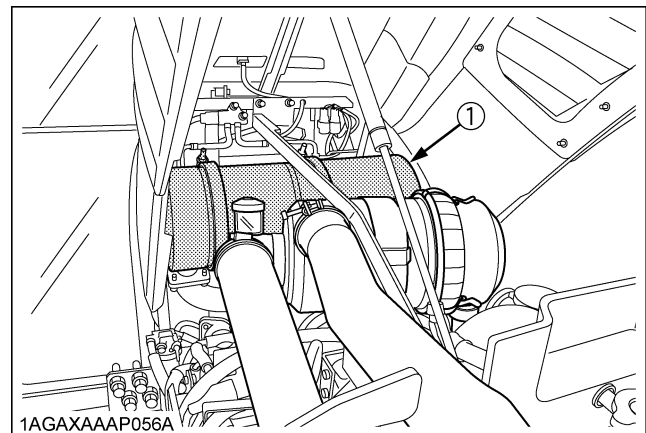

(1) Diesel Particulate Filter (DPF)

■ Handling Points

When a specific amount of PM (particulate matter) has accumulated in the DPF muffler, it is necessary to refresh the DPF muffler by burning the PM inside it. This burning off work is called "Regeneration".

To extend operating time to reach this regeneration, and to avoid DPF muffler trouble, make sure to observe the following handling matters.

◆ Fuel

Be sure to use Ultra Low Sulfur Fuel (S15).

IMPORTANT :

- Use of diesel fuel other than Ultra Low Sulfur Fuel may adversely affect the engine and DPF performance.
Use of fuels other than Ultra Low Sulfur Fuel (S15) may not meet regulations for your region.

◆ Engine oil

Use DPF-compatible oil (CJ-4) for the engine.

IMPORTANT :

- If any engine oil other than CJ-4 is used, the DPF may become clogged earlier than expected and the fuel economy may drop.

◆ Prohibition of unnecessary idling operation

Generally, the lower the engine speed, the lower the exhaust gas temperature is, so the PM contained in exhaust gas will not be burnt, and begins to accumulate. Therefore, don't idle unnecessarily.

◆ Regeneration

When there is "Regeneration" instruction sign by lamp or buzzer, immediately perform the required procedure for regeneration.

IMPORTANT :

- Interrupting the regeneration cycle or continued operation by ignoring the warning signs may cause DPF and engine damage.

■ DPF Regeneration Process

DPF regeneration process can be performed by choosing from "Auto Regeneration" or "Regeneration inhibit" mode according to your job conditions. For jobs not affected by hot gases emitted during regeneration, the "Auto Regeneration" is advisable.

◆ Auto Regeneration Mode;

When starting the engine (switch operation is unnecessary), the "Auto Regeneration" mode is automatically activated.

With the auto regeneration mode on, when a specific amount of PM has accumulated, and the regeneration conditions are satisfied (See the "Tips on Diesel Particulate Filter [DPF] Regeneration"), the DPF will be automatically regenerated whether the tractor is in motion or parked.

By this way, work efficiency is improved. For details of auto regeneration, refer to "Operating Procedure for Auto Regeneration Mode" section.

◆ Regeneration Inhibit Mode;

After starting the engine, if the "DPF INHIBIT switch" is pressed to turn on the switch lamp, the "Regeneration inhibit" mode will be activated.

With "Regeneration Inhibit" mode on, the PM which has accumulated inside the DPF will not be burnt, unless the operator performs the regeneration work manually.

The "Regeneration Inhibit" mode is effective for work in poorly ventilated work spaces.

For details of regeneration prohibition, refer to "Operating Procedure for Regeneration Inhibit Mode" section.

NOTE :

- If stop the engine once, the "Auto Regeneration" mode will be activated.

Operating Procedure for Auto Regeneration Mode

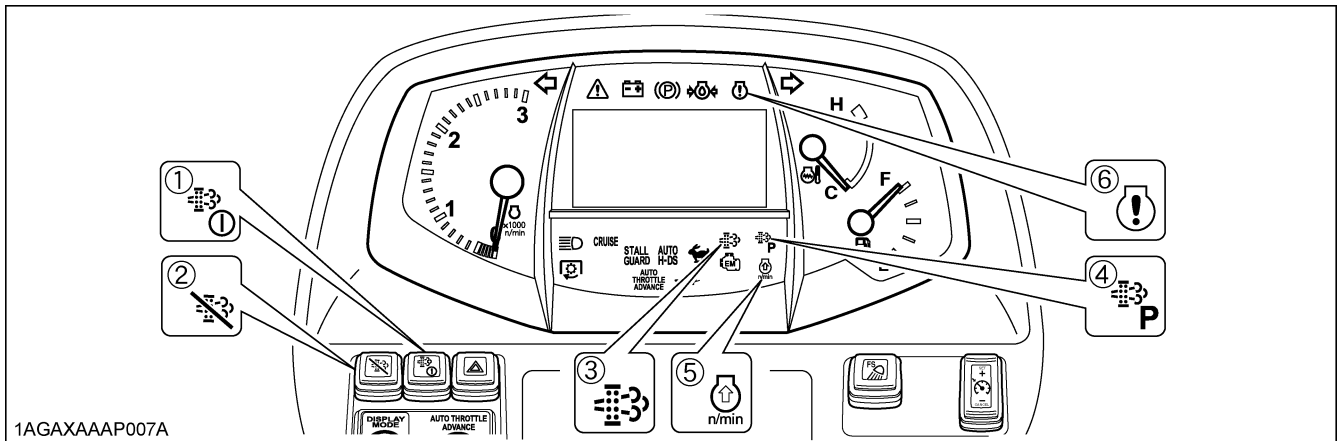

1AGAXAAP007A

- | | | |
|--------------------------------|-----------------------------------|-----------------------------------|
| (1) Parked regeneration switch | (3) Regeneration indicator | (5) Engine RPM increase indicator |
| (2) DPF INHIBIT switch | (4) Parked regeneration indicator | (6) Engine warning indicator |

Regeneration Operating Procedure

1. Start the engine.
(Make sure that the DPF INHIBIT switch lamp  is "OFF".)

Switch lamp OFF: Auto Regeneration Mode activated.
Switch lamp ON: Regeneration Inhibit Mode activated.

NOTE :

- When the engine is started, the "Auto Regeneration" mode is automatically activated.
- "Regeneration Inhibit" mode is activated, when the DPF INHIBIT switch is pushed after the engine is started.

2. When the regeneration indicator  starts flashing:

A specific amount of PM has built up in the DPF.
Continue to operate the tractor, and the regeneration process will begin automatically, make sure the working place is in a safe area as DPF and exhaust temperature will rise.

3. When the engine rpm increase indicator  starts flashing:

Keep on working and increase the engine rpm until the indicator turns "OFF".

NOTE :









- Even if the Auto Regeneration Mode is selected, DPF regeneration may not begin because system requirements have not been satisfied.
- The engine rpm increase indicator is used as a guide to satisfy the regeneration conditions. If the engine load is too heavy, the engine rpm increase indicator may continue to flash, even though regeneration system conditions are satisfied and regeneration may begin automatically. (See the "Tips on Diesel Particulate Filter [DPF] Regeneration")

■ PM Warning Level and Required Procedures

During Auto Regeneration Mode when the PM level has built up in the DPF, the regeneration cycle will begin automatically. If the regeneration cycle is interrupted or the regeneration conditions are not satisfied, the buzzer starts sounding and the indicator display changes in response to the PM level in order to prompt the operator to perform the required procedure listed below.

IMPORTANT :

- Once the regeneration level has been reached, immediately perform the required procedure for regeneration. Interrupting the regeneration cycle or continued operation by ignoring the warning signs may cause DPF and engine damage.

Auto Mode		
	DPF system status	Required procedure
PM warning level: 1 Buzzer: Not sounding	 The regeneration indicator starts flashing.  The RPM increase indicator starts flashing.  The regeneration indicator will stop flashing and remain "ON" constantly.	A specific amount of PM has accumulated in the DPF muffler. Continue to work the tractor to raise the DPF temperature. Continue the work and increase the engine rpm until the indicator turns "OFF". The regeneration cycle begins and continues until cycle is complete then the indicator will turn "OFF".
PM warning level: 2-1 Buzzer: Sounding every 5 seconds	If the regeneration cycle was interrupted or conditions are not satisfied for regeneration then DPF system is now in Level 2.  The regeneration indicator starts flashing.	Start the regeneration, referring to PM warning level: 1 above. Now the parked regeneration indicator starts flashing, and the parked regeneration can also be started. If the regeneration conditions are not met, perform the parked regeneration. ● For the procedure, refer to "Operating Procedure for Parked Regeneration".
PM warning level: 2-2 Buzzer: Sounding every 3 seconds	 The RPM increase indicator starts flashing.  The parked regeneration indicator starts flashing.	
PM warning level: 3 Buzzer: Sounding every 1 second Engine output: 50%	If the regeneration fails in the warning level 2:  The engine warning indicator starts flashing.  The parked regeneration indicator starts flashing.	Immediately discontinue working the tractor and begin the parked regeneration cycle process. ● For the procedure, refer to "Operating Procedure for Parked Regeneration". At this PM warning level, the Auto Regeneration Mode does not function. If the tractor is operated further, the regeneration cycle will be disabled.
PM warning level: 4 Buzzer: Sounding every 1 second Engine output: 50%	If the parked regeneration is interrupted or the tractor is continuously operated in the warning level 3:  The engine warning indicator remains constantly "ON".	Immediately move the tractor to a safe place and park it there and turn the engine "OFF". Contact your local KUBOTA Dealer. ● At this level, never continue to operate the tractor otherwise damage will result to the DPF and engine.

Operating Procedure for Regeneration Inhibit Mode

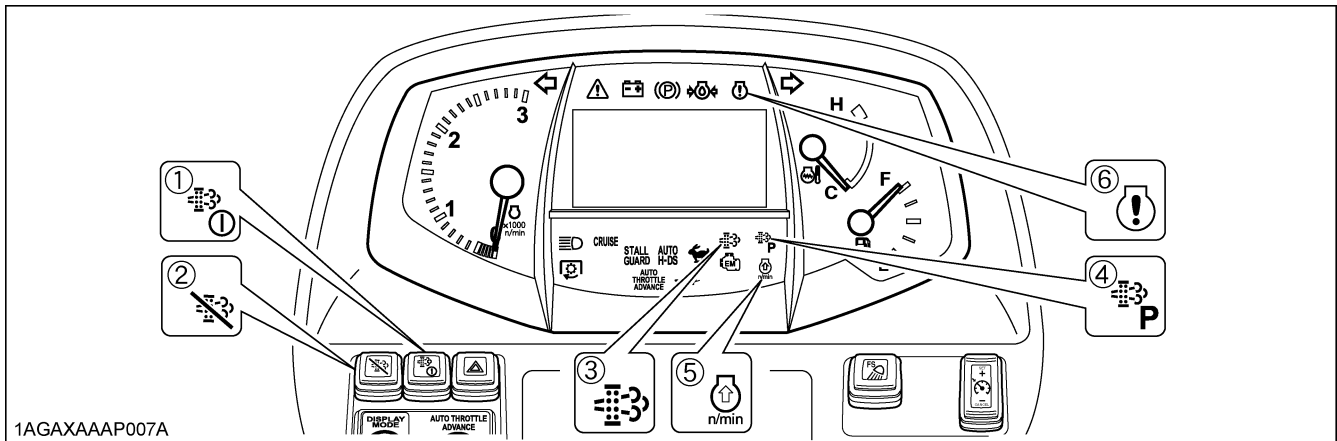

- | | | |
|--------------------------------|-----------------------------------|-----------------------------------|
| (1) Parked regeneration switch | (3) Regeneration indicator | (5) Engine RPM increase indicator |
| (2) DPF INHIBIT switch | (4) Parked regeneration indicator | (6) Engine warning indicator |

■ Regeneration Operating Procedure

1. Start the engine.

2. Press the DPF INHIBIT switch  , and the switch lamp illuminates.

Switch lamp ON: Regeneration Inhibit Mode selected.
 Switch lamp OFF: Auto Regeneration Mode selected.

3. When the parked regeneration indicator  starts flashing:







A specific amount of PM has accumulated in the DPF muffler. Move the tractor to a safe place and activates the DPF muffler. Follow the "Operating Procedure for Parked Regeneration" procedure.

■ PM Warning Level and Required Procedures





In the Regeneration Inhibit Mode, the buzzer starts sounding and the indicator display changes in response to the PM level in order to prompt the operator to perform the required procedure listed below.

IMPORTANT :

- Once the regeneration level has been reached, immediately perform the required procedure for regeneration. Interrupting the regeneration cycle or continued operation by ignoring the warning signs may cause DPF and engine damage.

Regeneration Inhibit Mode		
DPF system status		Required procedure
PM warning level: 1 Buzzer: Not sounding	 The regeneration indicator starts flashing.	A specific level of PM has built up in the DPF muffler. Continue with the operation as it is.
	 At PM warning levels range from 1 to 2-2, it is also possible to change DPF INHIBIT switch to auto regeneration mode then perform regeneration.	
PM warning level: 2-1 Buzzer: Sounding every 5 seconds	 The regeneration indicator starts flashing.	Move the tractor to a safe area, then follow the "Operating Procedure for Parked Regeneration".
PM warning level: 2-2 Buzzer: Sounding every 3 seconds	 The Parked regeneration indicator starts flashing.	
PM warning level: 3 Buzzer: Sounding every 1 second Engine output: 50%	If the parked regeneration cycle is interrupted or the tractor is continuously operated in the PM warning level 2:	
	 The engine warning indicator starts flashing.  The parked regeneration indicator starts flashing	Immediately stop working the tractor, move the tractor to a safe area, then follow the "Operating Procedure for Parked Regeneration". If the tractor is operated further and the operator ignores the warning signs, then regeneration will be disabled.
PM warning level: 4 Buzzer: Sounding every 1 second Engine output: 50%	If the regeneration cycle is interrupted or the tractor is continuously operated ignoring the warning signs, in the PM warning level 3:	
	 The engine warning indicator remains constantly "ON".	Immediately move the tractor to a safe place and place in park, turn "OFF" engine. Contact your local KUBOTA Dealer. <ul style="list-style-type: none"> ● At this level never continue to operate the tractor, otherwise damage may result to the DPF and engine.

Operating Procedure for Parked Regeneration

1. Park the tractor in a safe area away from buildings, people, and animals.
2. Apply the parking brake.
3. **[HST Type]**
Set the speed control pedal to the neutral position.
[GST / Manual Transmission Type]
Set the shuttle shift lever to the neutral position.
4. Turn "OFF" the PTO clutch control switch or lever.
5. Return the engine rpm to the idle speed.
6. Lower the implement to the ground.
Turn steering wheel so front wheels are in the straight ahead position.
7. Press the DPF INHIBIT switch , and the switch lamp turns "OFF".
8. When the regeneration conditions are satisfied (2 to 5 and 7 mentioned above),
the parked regeneration switch lamp  start flashing.
9. Press the parked regeneration switch  to start the regeneration cycle.
(The switch lamp will stop flashing and remain "ON" constantly during the cycle.)
10. The engine rpm will automatically rise, and the regeneration process will begin.
11. Both indicators   stay "ON" while regenerating the DPF.
They turn "OFF" when the cycle is complete.
12. After the lamp turns "OFF", normal tractor work may resume.
When driving in "Regeneration Inhibit" mode, press the DPF INHIBIT switch to turn on the switch lamp.

NOTE :

- During the regeneration cycle, do not touch the above levers, pedal and switches (in steps 2, 3, 4), nor change the engine rpm other than an emergency stop. Otherwise, the regeneration will be interrupted.
- Never leave the tractor when parked regeneration process is activated.
- If the parked regeneration cycle is interrupted, the engine rpm is fixed at the idling level for about 30 seconds. For this period, keep the hand throttle lever and foot throttle pedal at the idle position. Do not move them. They will function again in 30 seconds.

■ Tips on Diesel Particulate Filter (DPF) Regeneration

● Operation

The higher in speed or load the engine operates, the higher the exhaust temperature rises. As a result, particulate matter (PM) inside the DPF is consumed, therefore the regeneration process is required less frequently over time.

The lower in speed or load the engine operates, the lower the exhaust temperature. Accordingly, less particulate matter (PM) inside the DPF is consumed, therefore more accumulation of PM will occur, which requires frequent regeneration, therefore avoid prolonged idling if possible.

● Necessary conditions for "Regeneration"

When conditions below are all satisfied, regeneration will start. However, if even one condition is deviated during the process, the regeneration will be interrupted.

- (1) The engine coolant temperature.
- (2) The DPF temperature.
- (3) The engine speed is 1200 rpm or higher.

● Usually it takes 15-20 minutes to complete the regeneration cycle.

Actual regeneration time may depend on ambient temperature, exhaust temperature and engine speed.

● It is recommended to do the regenerating while the engine is warm.

● Do not unnecessarily start and interrupt the regeneration process. Otherwise, a small amount of fuel becomes mixed with the engine oil, which degrades the oil quality.

● While the DPF is being regenerated, the engine air flow rate is automatically limited to keep up the exhaust temperature. Because of this the engine may sound differently, this is normal for this engine.

● Just after the regeneration has ended, the DPF muffler remains hot. It is advisable to keep the engine running for about 5 minutes to allow cooling of the exhaust components.

STARTING THE ENGINE

1. Make sure the parking brake is set.

1. To set the parking brake;
 - (1) Interlock the brake pedals.
 - (2) Depress the brake pedals.
 - (3) Latch the brake pedals with the parking brake lever.
2. To release the parking brake, depress the brake pedals again.

[GST / Manual Transmission Type]

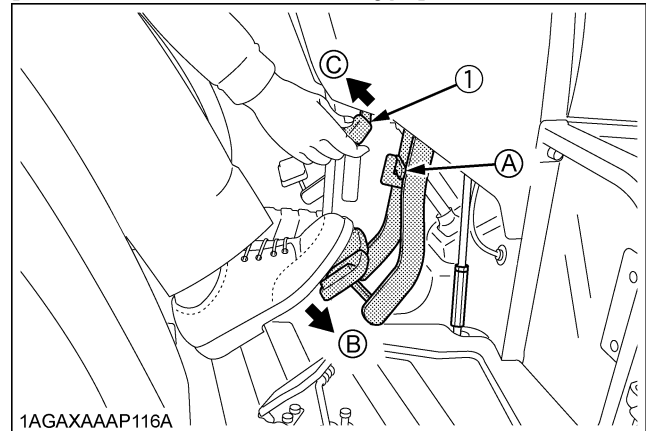

[HST Type]

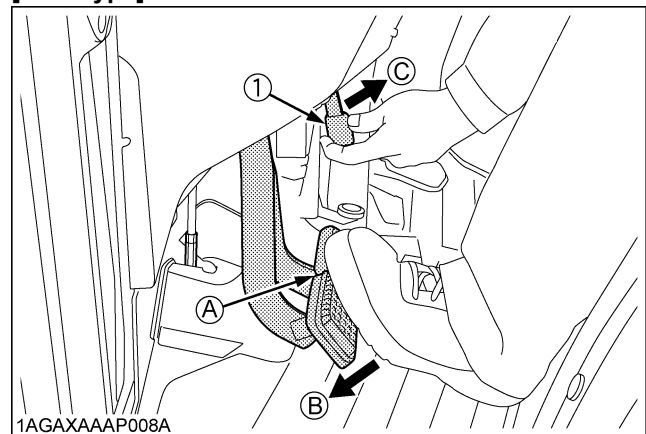

- (1) Parking brake lever (A) Interlock the brake pedals
 (B) "DEPRESS"
 (C) "PULL"

IMPORTANT :

- To prevent damage to the parking brake lever, make sure that brake pedals are fully depressed before pulling the parking brake lever up.

NOTE :

- The Parking brake indicator comes on while parking brake is applied and goes off when it is released.

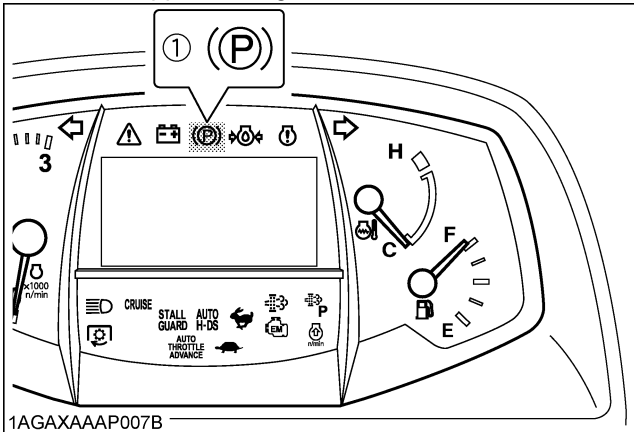

(1) Parking brake indicator

2. Make sure the fuel cock is in the open position.

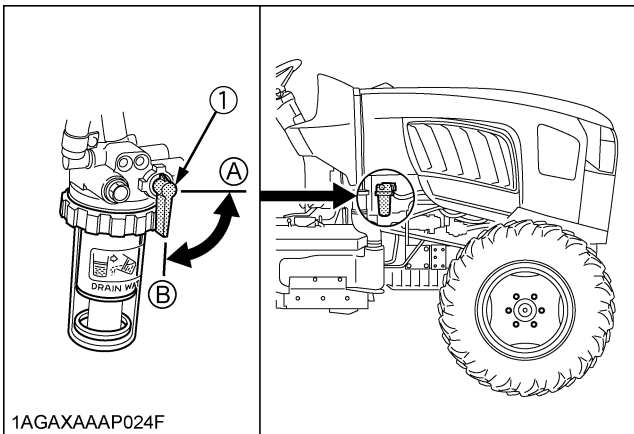

(1) Fuel cock

(A) "CLOSE"
(B) "OPEN"

3. Place the shift levers in "NEUTRAL" position.

[GST Type]

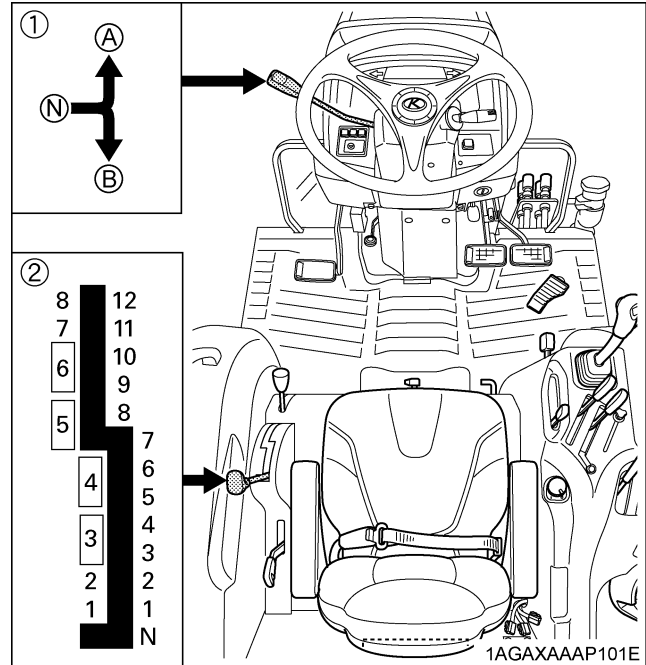

(1) Shuttle shift lever
(2) Main gear shift lever

(A) "FORWARD"
(B) "REVERSE"
(N) "NEUTRAL POSITION"

[Manual Transmission Type]

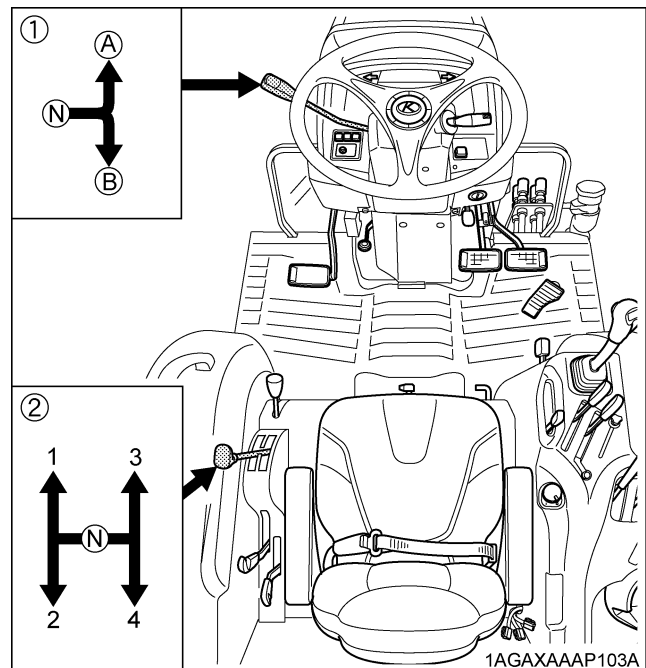

(1) Synchro shuttle shift lever
(2) Main gear shift lever

(A) "FORWARD"
(B) "REVERSE"
(N) "NEUTRAL POSITION"

- Place the Speed control Pedal in "NEUTRAL" position.
Place the range gear shift lever in "NEUTRAL" position.

[HST Type]

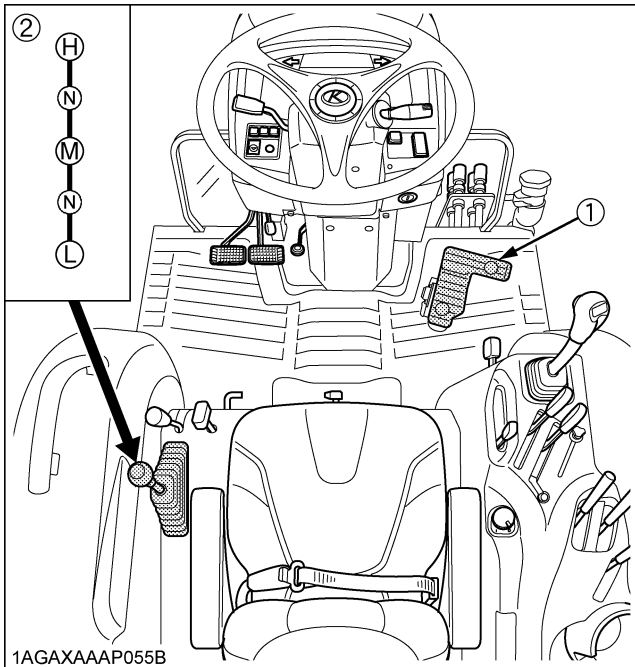

(1) Speed control pedal (N) "NEUTRAL POSITION"
(2) Range gear shift lever

NOTE :

- When removing the foot from speed control pedal, the pedal automatically returns to the neutral position.

- Place the PTO clutch control switch in "OFF" position.

[With Mid-PTO type]
Place the Mid-PTO lever in "OFF" position.

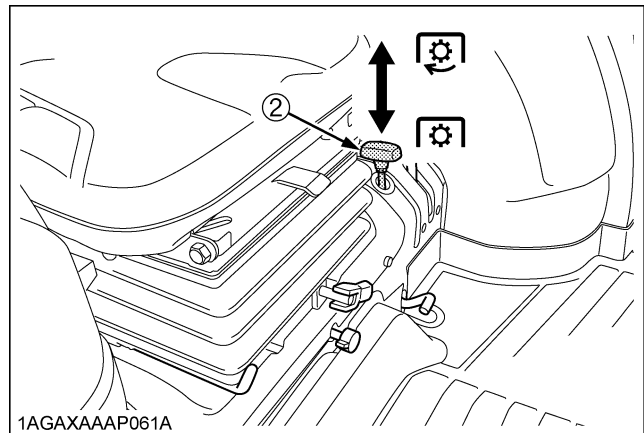
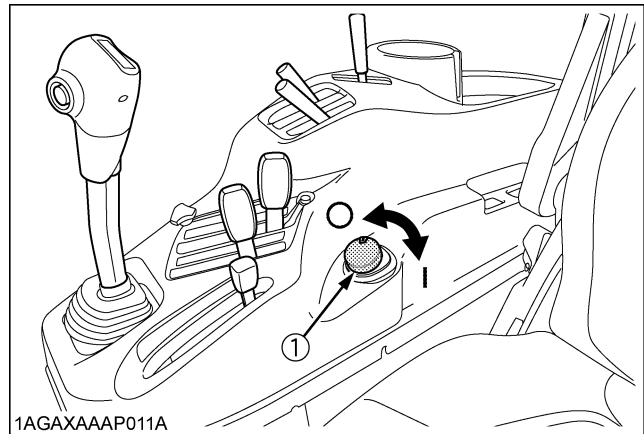

(1) PTO clutch control switch
(2) Mid-PTO lever

| ⚙️ "ON"
 ○ ⚙️ "OFF"

5. Place the hydraulic control lever in "LOWEST" position.

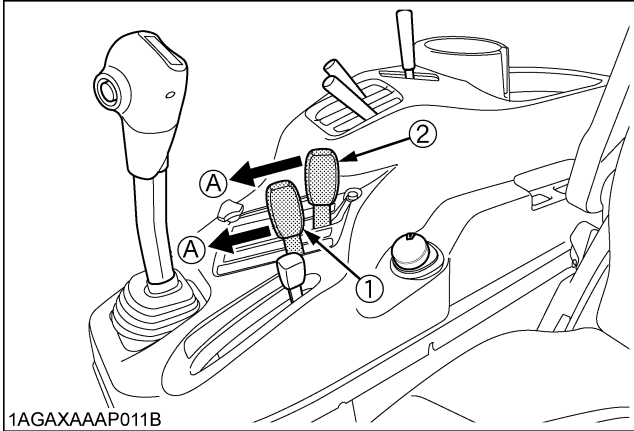

(1) Draft control lever (if equipped) (A) "DOWN"
 (2) Position control lever

6. Set the throttle lever at the minimum speed position.

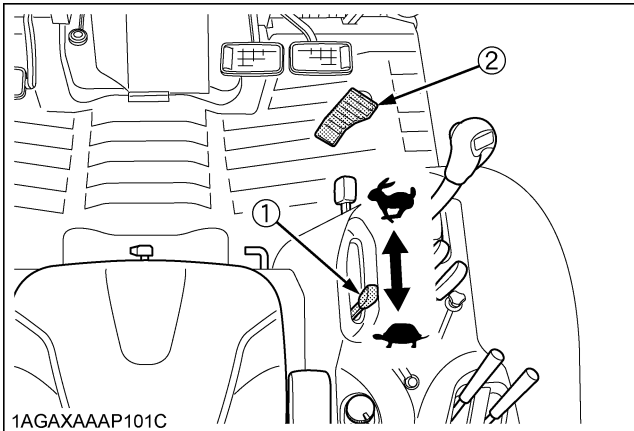

(1) Hand throttle lever ↖ "INCREASE"
 (2) Foot throttle ↘ "DECREASE"
 [except HST Type]

7. Insert the key into the key switch and turn it "ON".

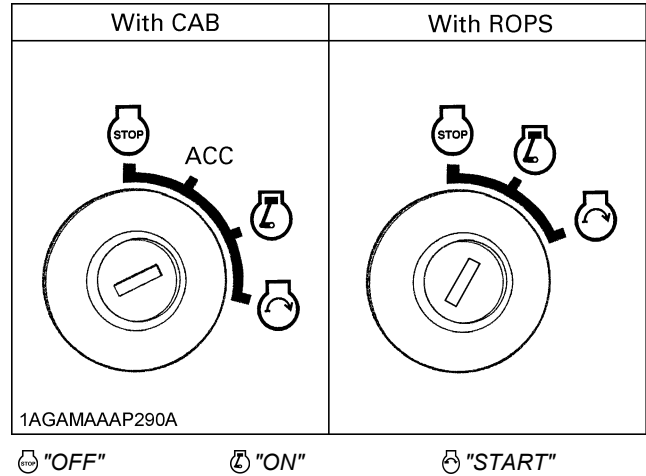

NOTE:

ACC... All the accessories can be used while the engine is stopped.

◆ Check Easy Checker(TM) Lamps

Turn the key to "ON" position and make sure the following indicators light up or stay off.

◆ Indicators that light up:

1. When the key is turned "ON", indicators(1)(3) should come on. If trouble should occur at any location while the engine is running, the indicator corresponding to that location comes on.
2. Suppose that the engine coolant temperature is not high enough yet. Glow plug indicator(5) also comes on when the key is turned "ON" to preheat the engine and goes off automatically when preheat is completed. Illumination time of indicator varies according to the temperature of coolant.
3. The parking brake indicator(2) comes on while parking brake is applied and goes off when it is released.

◆ **Indicators that stay off:**

1. If the PTO indicator(4) stays on, disengage (OFF) the PTO.

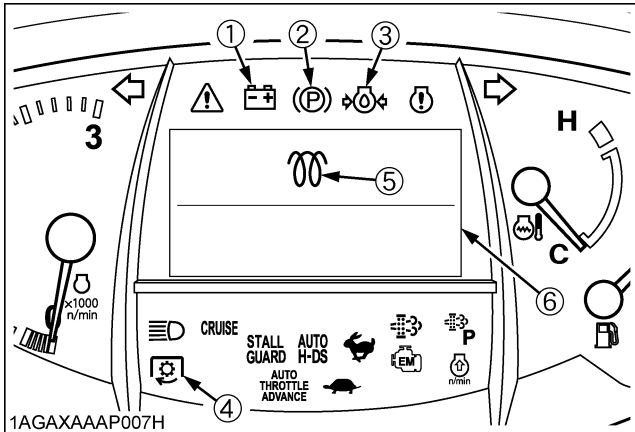

- | | |
|-----------------------------------|------------------------------|
| (1) Electrical charge indicator | (4) PTO indicator |
| (2) Parking brake indicator | (5) Glow plug indicator |
| (3) Engine oil pressure indicator | (6) IntelliPanel(TM) display |

IMPORTANT :

- Daily checks with the Easy Checker(TM) only, are not sufficient. Never fail to conduct daily checks carefully by referring to Daily Check. (See "DAILY CHECK" in "PERIODIC SERVICE" section.)

NOTE :

- Some of the Easy Checker(TM) lamps may light up depending on the positions of the levers and switches.
- Turn on the key, and some of the indicators stay on about 1 second.

8. Fully depress the clutch pedal.

[GST / Manual Transmission Type]

9. Turn the key to "START" position and release when the engine starts.

◆ **IntelliPanel(TM) Message**

If you try to start the engine but the following message appears in the display, the engine fails to start. Follow the appearing instructions and reset the display.

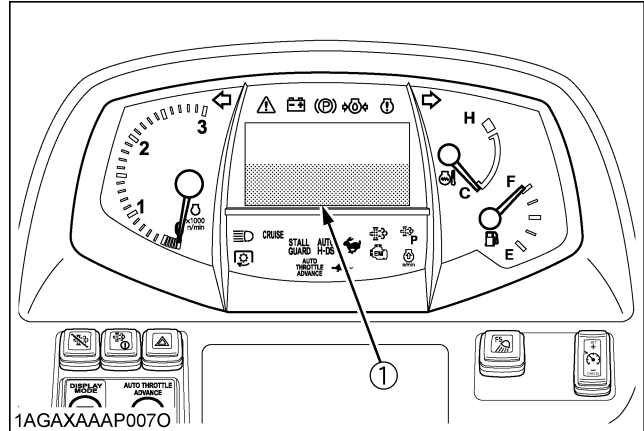

(1) Display

[GST / Manual Transmission Type]

**Disengage PTO
Set Shuttle to Neutral**

Turn the PTO clutch control switch to "OFF" and place the shuttle shift lever in "NEUTRAL" position.

Disengage PTO

Turn the PTO clutch control switch to "OFF".

Set Shuttle to Neutral

Place the shuttle shift lever in "NEUTRAL" position.

[HST Type]

**Disengage PTO
Set HST Pedal to Neutral**

Turn the PTO clutch control switch to "OFF" and foot off of the speed control pedal.

Disengage PTO

Turn the PTO clutch control switch to "OFF".

Set HST Pedal to Neutral

Foot off of the speed control pedal.

10. Check to see that all the lamps on the Easy Checker(TM) are "OFF".

If the lamp is still on, immediately stop the engine and determine the cause.

11. Release the clutch pedal.

[GST / Manual Transmission Type]

COLD WEATHER STARTING

If the ambient temperature is below -5 °C (23 °F) and the engine is very cold, follow the procedure below after taking the step 1 through 8 in the previous pages.

9. Turn the key to "ON" (glow plug) and keep it there until glow plug indicator goes off.

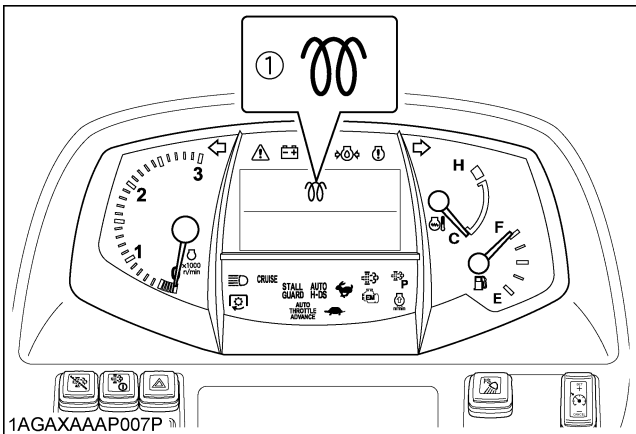

(1) Glow plug indicator

10. Turn the key to the start position and the engine should start.

(If the engine fails to start after 10 seconds, turn off the key for 30 seconds. Then repeat steps (9) and (10). To protect the battery and the starter, make sure that the starter is not continuously turned for more than 10 seconds.)

Antifrost Heater for Oil Separator (if equipped)

The heater element operates continuously when the key switch is in run position.

Due to high electrical draw, extended idle time or operations will drain the battery and stop the tractor.

[L5060, L5460, L6060]

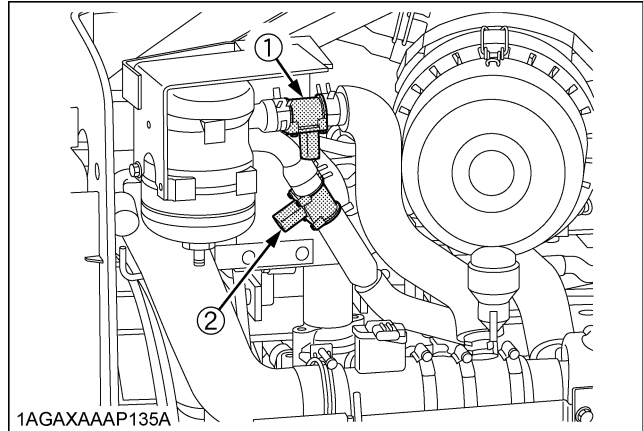

(1) Heater (Oil separator, OUT)

(2) Heater (Oil separator, IN)

[L3560, L4060, L4760]

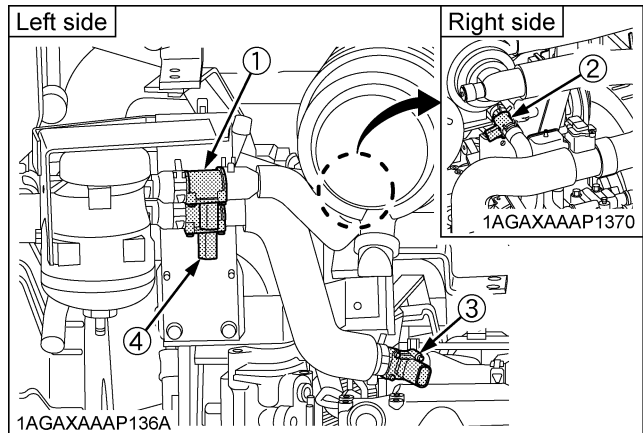

(1) Heater (Oil separator, OUT 1)

(2) Heater (Oil separator, OUT 2)

(3) Heater (Oil separator, IN 1)

(4) Heater (Oil separator, IN 2)

Block Heater (if equipped)

A block heater is available as an option from your dealer. It will assist you in starting your tractor when the ambient temperature is below -20 °C (-4 °F).

STOPPING THE ENGINE

[L3560, L4060, L4760]

1. After slowing the engine to idle, turn the key to "OFF".
2. Remove the key.

NOTE :

- If key does not stop the engine, consult your local KUBOTA Dealer.

[L5060, L5460, L6060]

1. After slowing the engine to idle, wait 3 to 5 minutes for turbo to slow down then turn the key to "OFF".
2. Remove the key.

NOTE :

- If key does not stop the engine, consult your local KUBOTA Dealer.

WARMING UP



WARNING

To avoid personal injury or death:

- Be sure to set the parking brake during warm-up.
- Be sure to set all shift levers to the "NEUTRAL" positions and to place PTO clutch control switch in "OFF" position during warm-up.

For 5 minutes after engine start-up, allow engine to warm up without applying any load, this is to allow oil to reach every engine part. If load should be applied to the engine without this warm-up period, trouble such as seizure, breakage or premature wear may develop.

■ Warm-Up Transmission Oil in the Low Temperature Range

Hydraulic oil serves as transmission fluid. In cold weather, the oil may be cold with increased viscosity. This can cause delayed oil circulation or abnormally low hydraulic pressure for some time after engine start-up. This in turn can result in trouble in the hydraulic system. To prevent the above, observe the following instructions:

Warm up the engine at about 50% of rated rpm according to the table below:

Ambient temperature	Warm-up time requirement
Higher than -10 °C (14 °F)	Approx. 5 minutes
-15 to -10 °C (5 to 14 °F)	5 to 10 minutes
-20 to -15 °C (-4 to 5 °F)	10 to 20 minutes
Below -20 °C (-4 °F)	More than 20 minutes

IMPORTANT :

- Do not operate the tractor under full load condition until it is sufficiently warmed up.

JUMP STARTING



WARNING

To avoid personal injury or death:

- Battery gases can explode. Keep cigarettes, sparks, and flames away from battery.
- If tractor battery is frozen, do not jump start engine.
- Do not connect the other end of the negative (-) jumper cable to the negative (-) terminal of the tractor battery.

When jump starting the engine, follow the instructions below to safely start the engine.

1. Bring the helper vehicle with a battery of the same voltage as disabled tractor within easy cable reach. "THE VEHICLES MUST NOT TOUCH".
2. Engage the parking brakes of both vehicles and put the shift levers in neutral. Shut both engines off.
3. Wear eye protection and rubber gloves.
4. Attach the red clamp to the positive (red, (+) or pos.) terminal of the dead battery and clamp the other end of the same cable to the positive (red, (+) or pos.) terminal of the helper battery.
5. Clamp the other cable to the negative (black, (-) or neg.) terminal of the helper battery.
6. Clamp the other end to the engine block or frame of the disabled tractor as far from the dead battery as possible.
7. Start the helper vehicle and let its engine run for a few moments. Start the disabled tractor.
8. Disconnect the jumper cables in the exact reverse order of attachment. (Steps 6, 5 and 4).

IMPORTANT :

- This machine has a 12 volt negative (-) ground starting system.
- Use only same voltage for jump starting.
- Use of a higher voltage source on tractor's electrical system could result in severe damage to tractor's electrical system.
Use only matching voltage source when "Jump starting" a low or dead battery condition.
- Do not operate the tractor with the battery cable disconnected from the battery.
- Do not operate the tractor without the battery mounted.
- Do not operate the tractor with the battery dead. Charge the battery fully enough before operating the tractor.
Otherwise the tractor might malfunction.

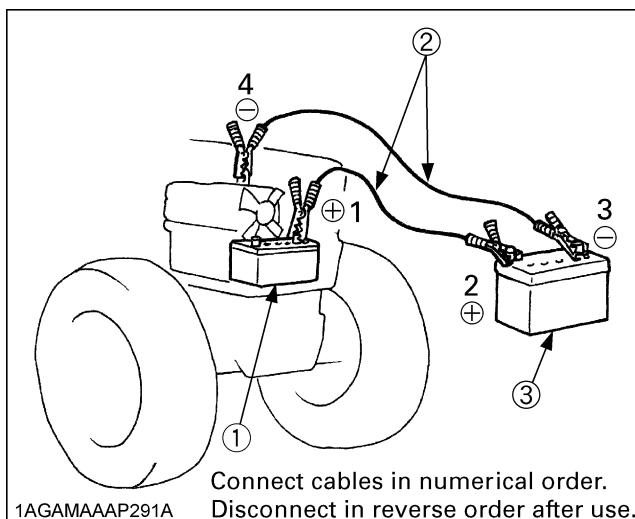

- (1) Dead battery
(2) Jumper cables
(3) Helper battery

OPERATING THE TRACTOR

OPERATING NEW TRACTOR

How a new tractor is handled and maintained determines the life of the tractor.

A new tractor just off the factory production line has been, of course, tested, but the various parts are not accustomed to each other, so care should be taken to operate the tractor for the first 50 hours at a slower speed and avoid excessive work or operation until the various parts become "broken-in". The manner in which the tractor is handled during the "breaking-in" period greatly affects the life of your tractor. Therefore, to obtain the maximum performance and the longest life of the tractor, it is very important to properly break-in your tractor. In handling a new tractor, the following precautions should be observed.

■ Do not Operate the Tractor at Full Speed for the First 50 Hours

- Do not start quickly nor apply the brakes suddenly.
- In winter, operate the tractor after fully warming up the engine.
- Do not run the engine at speeds faster than necessary.
- On rough roads, slow down to suitable speeds.
Do not operate the tractor at fast speed.

The above precautions are not limited only to new tractors, but to all tractors. But it should be especially observed in the case of new tractors.

■ Changing Lubricating Oil for New Tractors

The lubricating oil is especially important in the case of a new tractor. The various parts are not "broken-in" and are not accustomed to each other; small metal grit may develop during the operation of the tractor; and this may wear out or damage the parts. Therefore, care should be taken to change the lubricating oil a little earlier than would ordinarily be required.

For further details of change interval hours.
(See "MAINTENANCE" section.)

BOARDING AND LEAVING THE TRACTOR

1. Never try to get on or off a moving tractor or jump off the tractor to exit.
2. Face the tractor when getting into or out of the tractor. Do not use the controls as hand holds to prevent inadvertent machine movements.
3. Always keep steps and floor clean to avoid slippery conditions.

OPERATING FOLDABLE ROPS (if equipped)



WARNING

To avoid personal injury or death:

- When raising or folding the ROPS, apply parking brake, stop the engine and remove the key.
Always perform function from a stable position at the rear of tractor.
- Fold the ROPS down only when absolutely necessary and fold it up and lock it again as soon as possible.
- Before proceeding to fold ROPS, check for any possible interference with installed implements and attachments.
If interference occurs, contact your KUBOTA Dealer.

■ To Fold the ROPS

1. Remove both set bolts.

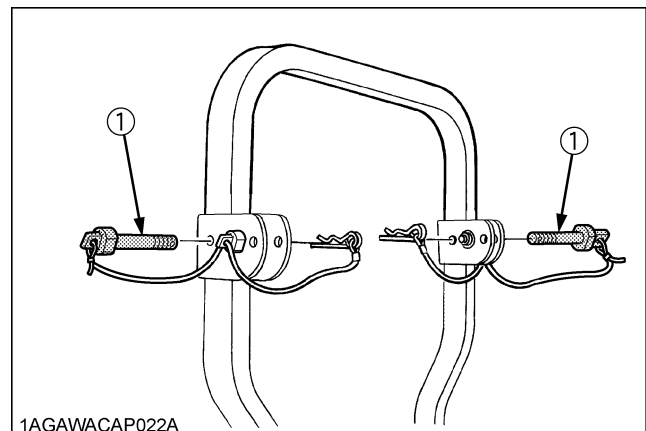

1AGAWACAP022A

(1) Set bolt

2. Fold the ROPS.



CAUTION

To avoid personal injury:

- Hold the ROPS tightly with both hands and fold the ROPS slowly and carefully.

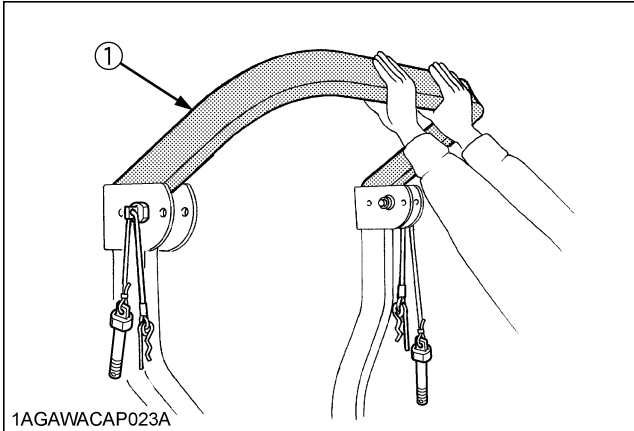

1AGAWACAP023A

(1) ROPS

3. Align set bolt holes and insert both set bolts. Slightly tighten the set bolts and secure them with the hair pin cotters.



CAUTION

To avoid personal injury:

- Make sure that both set bolts are properly installed and secured with the hair pin cotters.

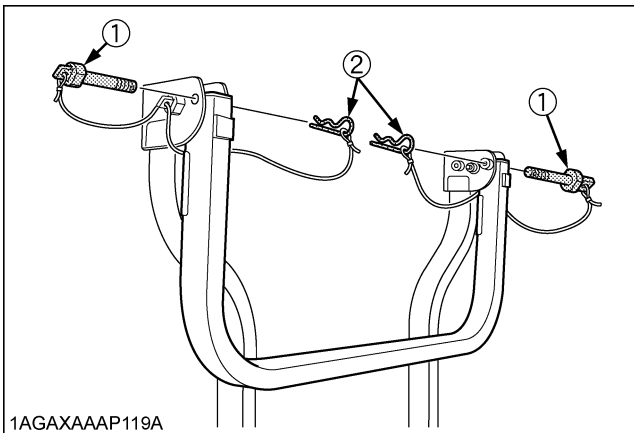

1AGAXAAP119A

(1) Set bolt
(2) Hair pin cotter

To Raise the ROPS to Upright Position

1. Remove both hair pin cotters and set bolts.

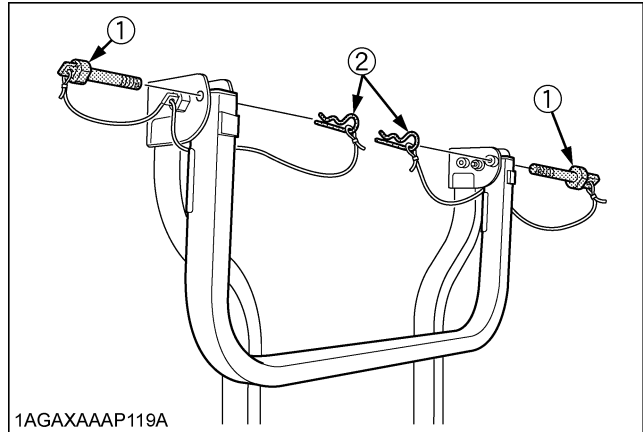

1AGAXAAP119A

(1) Set bolt
(2) Hair pin cotter

2. Raise ROPS to the upright position.



CAUTION

To avoid personal injury:

- Raise the ROPS slowly and carefully.

3. Align set bolt holes, insert both set bolts. Slightly tighten the set bolts and secure them with the hair pin cotters.



CAUTION

To avoid personal injury:

- Make sure that both set bolts are properly installed as soon as the ROPS is in the upright position and secured with the hair pin cotters.

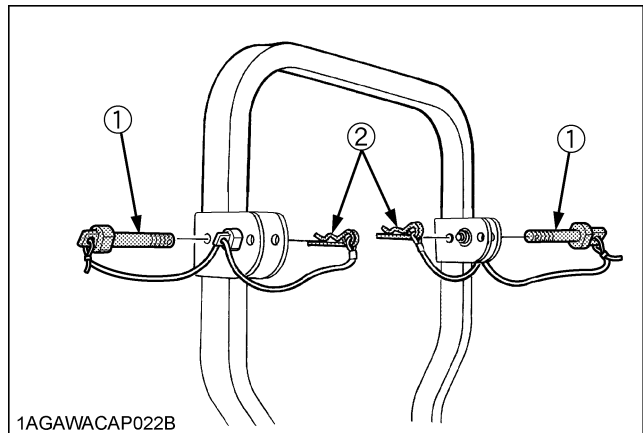

1AGAWACAP022B

(1) Set bolt
(2) Hair pin cotter

■ Adjustment of Foldable ROPS

- Adjust free fall of the ROPS upper frame regularly.
- If you feel less friction in folding the ROPS, remove the cotter pin (1), tighten the nut (2) until you feel the right friction in the movement and then replace the cotter pin.

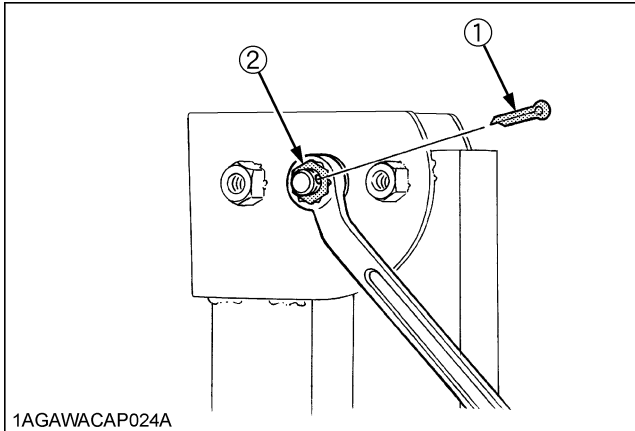

1AGAWACAP024A

- (1) Cotter pin
(2) Nut

STARTING

1. Adjusting the operator's position.

NOTE :

- The seat and suspension should be adjusted to ensure that the controls are comfortably at hand for the operator, ensuring that the operator maintains a good posture and minimizes risks from whole body vibration.

■ Operator's Seat



WARNING

To avoid personal injury or death:

- Make adjustments to the seat only while the tractor is stopped.
- Make sure that the seat is completely secured after each adjustment.
- Do not allow any person other than the operator to ride on the tractor.

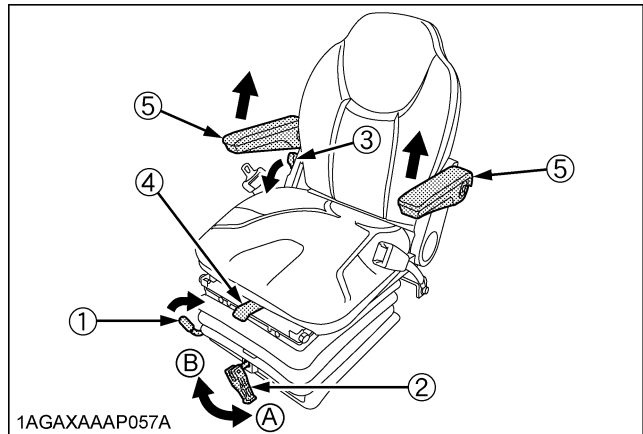

1AGAXAAP057A

- (1) Travel adjust lever (A) To decrease tension
(2) Suspension adjust knob (B) To increase tension
(3) Backrest tilt adjust lever
(4) Swivel adjust lever
(5) Arm rest

◆ Travel adjustment

Unlock the travel adjust lever and slide the seat backward or forward, as required. The seat will lock in position when the lever is released.

NOTE :

- The operator's seat base has a slope. When lifting the lever, be careful not to allow the seat to slide down forward.

◆ Suspension adjustment

Turn the suspension adjust lever to achieve the optimum suspension setting.

◆ Tilt adjustment

Unlock the backrest tilt adjust lever and move the backrest to the desired angle.

◆ Arm rest

Arm rest may be set at upright position if desired.

◆ Swivel adjustment

Unlock the swivel adjust lever and rotate the seat right or left as desired.

NOTE :

Using the swivel seat

- Swivel the seat to the right and left to position yourself comfortably for jobs in which you need to look rearwards.
- Turn the seat to the left to facilitate getting in and out of the tractor.
- The seat can swivel in both directions.

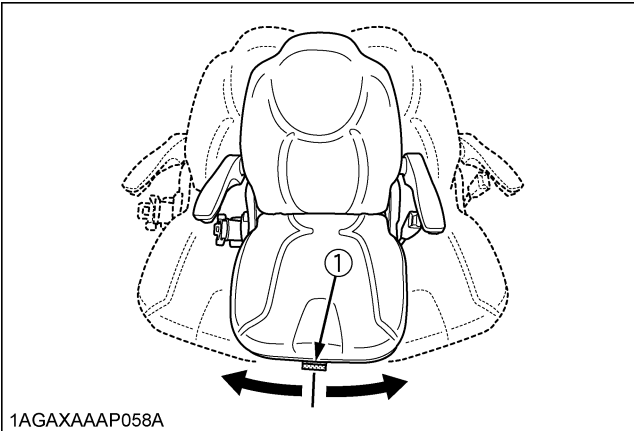

1AGAXAAP058A

(1) Swivel adjust lever

IMPORTANT :

- After adjusting the operator's seat, be sure to check to see that the seat is properly locked.

■Glove Box

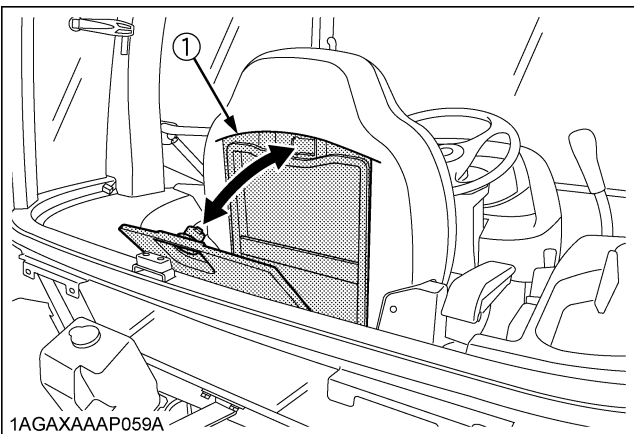

1AGAXAAP059A

(1) Glove box

■Seat Belt



WARNING

To avoid personal injury or death:

- Always use the seat belt when any ROPS or CAB are installed.
- Do not use the seat belt if a foldable ROPS is down or there is no ROPS.

Adjust the seat belt for proper fit and connect the buckle. This seat belt is auto-locking retractable type.

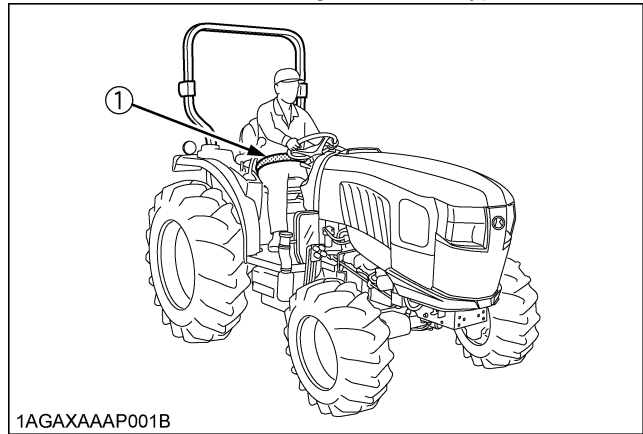

1AGAXAAP001B

(1) Seat belt

■Tilt Steering Adjustment



CAUTION

To avoid personal injury:

- Do not adjust the steering wheel while the tractor is in motion.

Press down the steering wheel tilt pedal, to release the lock so the steering wheel can be adjusted to one of 6 desired positions.

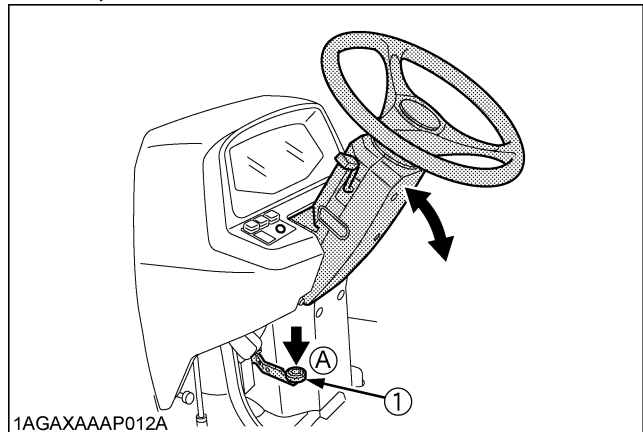

1AGAXAAP012A

(1) Steering wheel tilt pedal (A) "PRESS DOWN"

2. Selecting light switch positions.

■ Light Switch

Turn the light switch clockwise, and the following lights are activated on the switch position.

- OFF..... Head lights OFF.
- ☉..... Head lights dimmed, low beam.
- ☉..... Head lights ON, high beam.

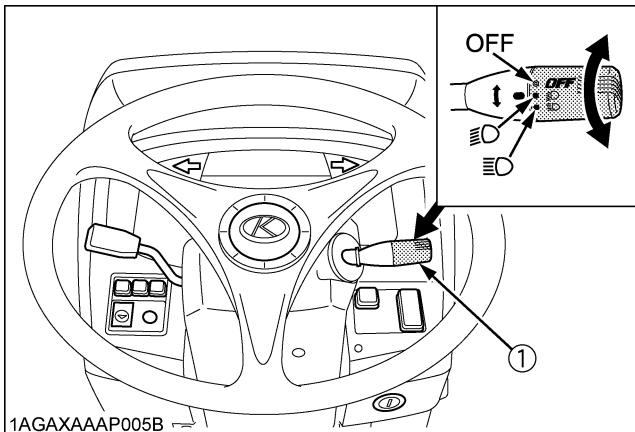

1AGAXAAP005B

(1) Head light switch

■ Turn Signal / Hazard Light Switch

◆ Hazard Light

1. When the hazard light switch is pushed, the hazard lights flash, along with the L/H and R/H indicators on the instrument panel.
2. Push the hazard light switch again to turn off the hazard lights.

◆ Turn Signal with Hazard Light

1. To indicate a right turn with the hazard lights already flashing, turn the switch clockwise.
2. To indicate a left turn with the hazard lights already flashing, turn the switch counterclockwise.
3. When the left or right turn signal is activated in combination with the hazard lights, the indicated turning light will flash and the other will stay on.

◆ Turn Signal without Hazard Light

1. To indicate a right turn without hazard lights, turn the switch clockwise.
2. To indicate a left turn without hazard lights, turn the switch counterclockwise.
3. When the left or right turn signal is activated without the hazard lights, the indicated turning light will flash and the other will stay on.

NOTE :

- The hazard light switch is operative when the key switch is in either the "ON" or "OFF" position.
- The turn signal light switch is only operative when the key switch is in the "ON" position.
- Be sure to return the turn signal switch to center position after turning.

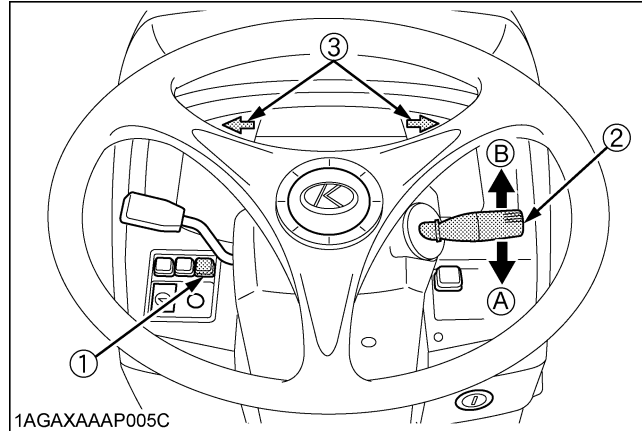

1AGAXAAP005C

- (1) Hazard light switch
- (2) Turn signal light switch
- (3) Hazard / Turn signal indicator

- (A) "RIGHT TURN"
- (B) "LEFT TURN"

■ Horn Button (if equipped)

The horn will sound when the key switch is in the "ON" position and the horn button pressed.

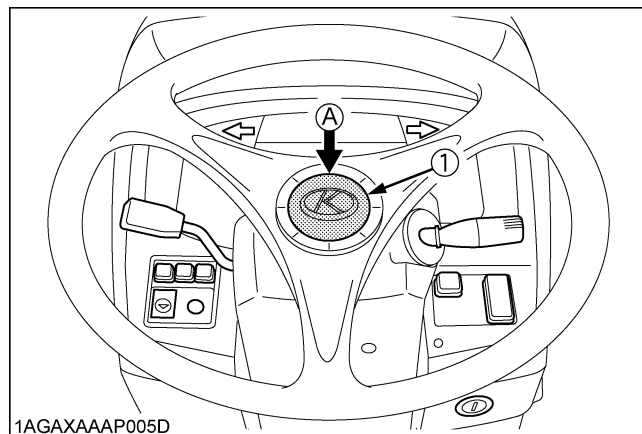

1AGAXAAP005D

- (1) Horn button
- (A) "PUSH"

Side Work Light Switch



WARNING

To avoid personal injury or death:

- Do not operate on roads with work lights on. Work lights may blind or confuse operators of oncoming vehicles.

Turn on the key switch and press the side work light switch. The work lights and the switch's indicator light up. Press the switch to turn off the light and indicator.

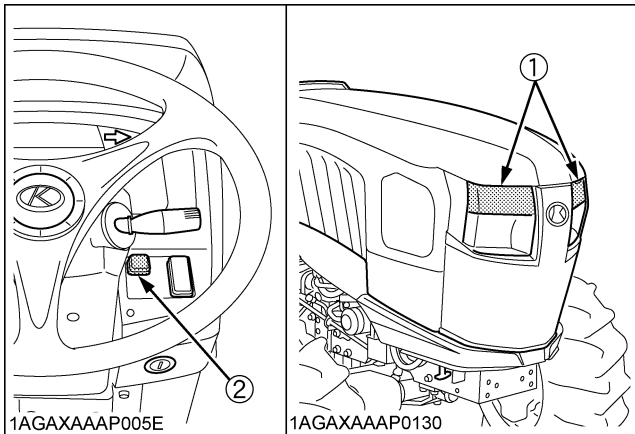

- (1) Side work light
- (2) Side work light switch with indicator

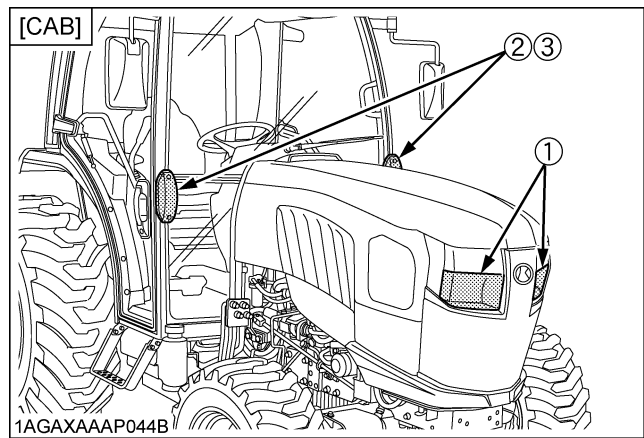
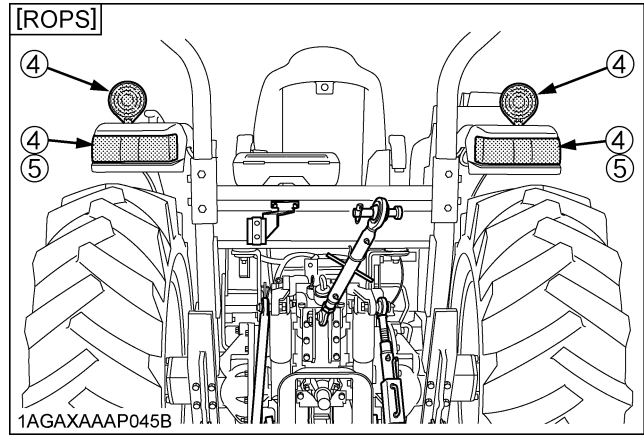

Tractor Lights

- (1) Head light
- (2) Turn signal / Hazard light
- (3) Side marker light
- (4) Rear turn signal / Hazard light
- (5) Tail light

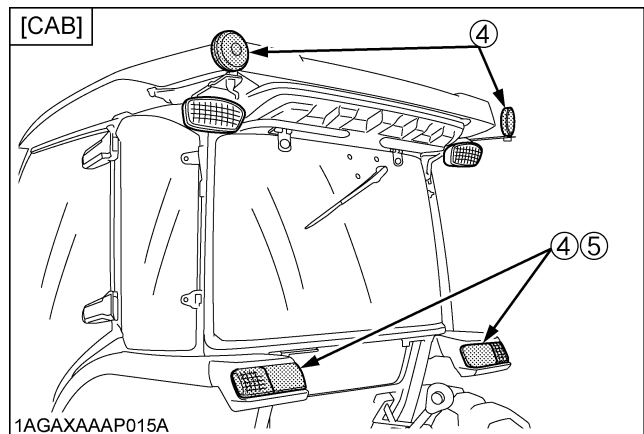
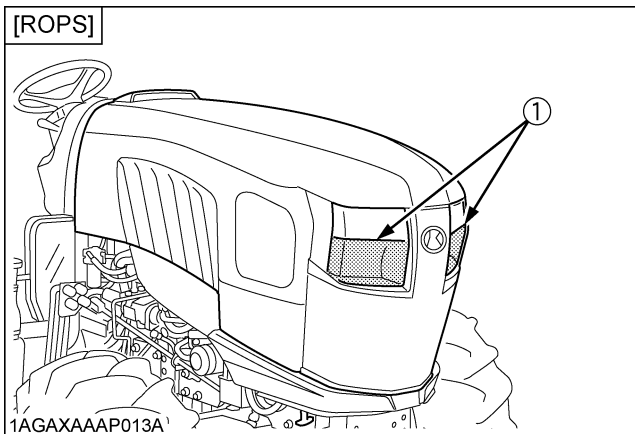

3. Checking the brake pedal.

■ Brake Pedals (Right and Left)



WARNING

To avoid personal injury or death:

- Be sure to interlock the right and left pedals. Applying only one rear wheel brake at high speeds could cause the tractor to swerve or roll-over.
- Be sure brake pedals have equal adjustment when using locked together. Incorrect or unequal brake pedal adjustment can cause the tractor to swerve or roll-over.



WARNING

To avoid personal injury or death:

- Do not make brake suddenly. An accident may occur as a result of a heavy towed load shifting forward or loss of control.
- To avoid skidding and loss of steering control when driving on icy, wet, or loose surfaces, make sure the tractor is correctly ballasted, operated at reduced speed, operated with front wheel drive engaged (if equipped).
- The braking characteristics are different between 2 and 4-wheel drive. Be aware of the difference and use carefully.

1. Before operating the tractor on the road or before applying the parking brake, be sure to interlock the right and left pedals as illustrated below.
2. Use individual brakes to assist in making sharp turns at slow speeds (Field Operation Only). Disengage the brake pedal lock and depress only one brake pedal.
3. Be sure brake pedals have equal adjustment when using locked together.

[GST / Manual Transmission Type]

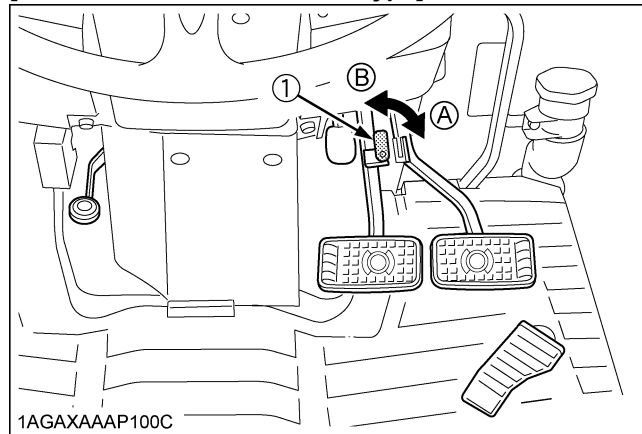

[HST Type]

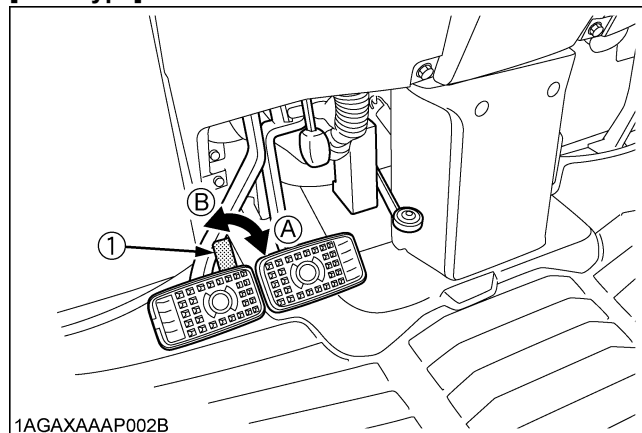

(1) Brake pedal lock

(A) "LOCK"

(B) "RELEASE"

**4. Raise the implement.
(See "HYDRAULIC UNIT" section.)**

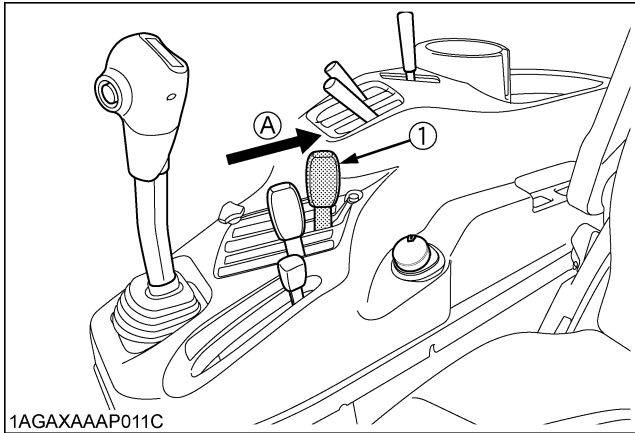

1AGAXAAP011C

(1) Position control lever (A) "UP"

5. Depress the clutch pedal.

[GST / Manual Transmission Type]

■ **Clutch Pedal**



WARNING

To avoid personal injury or death:

- Sudden release of the clutch may cause the tractor to lunge in an unexpected manner.

The clutch is disengaged when the clutch pedal is fully pressed down.

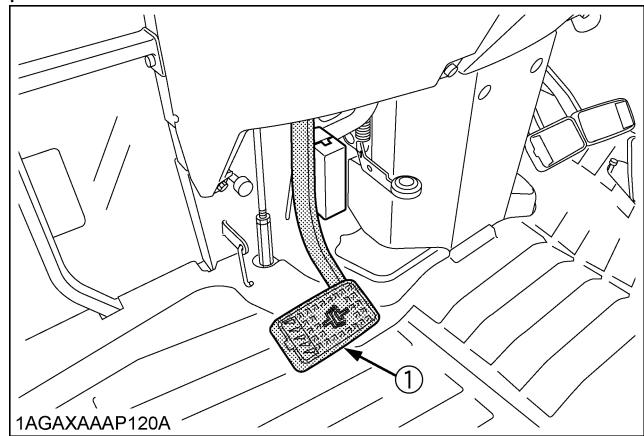

1AGAXAAP120A

(1) Clutch pedal

IMPORTANT :

To help prevent premature clutch wear:

- The clutch pedal must be quickly disengaged and be slowly engaged.
- Avoid operating the tractor with your foot resting on the clutch pedal.
- Select proper gear and engine speed depending on the type of job.

HST

GST

MT

6. Selecting the Travel Speed.

[HST Type]

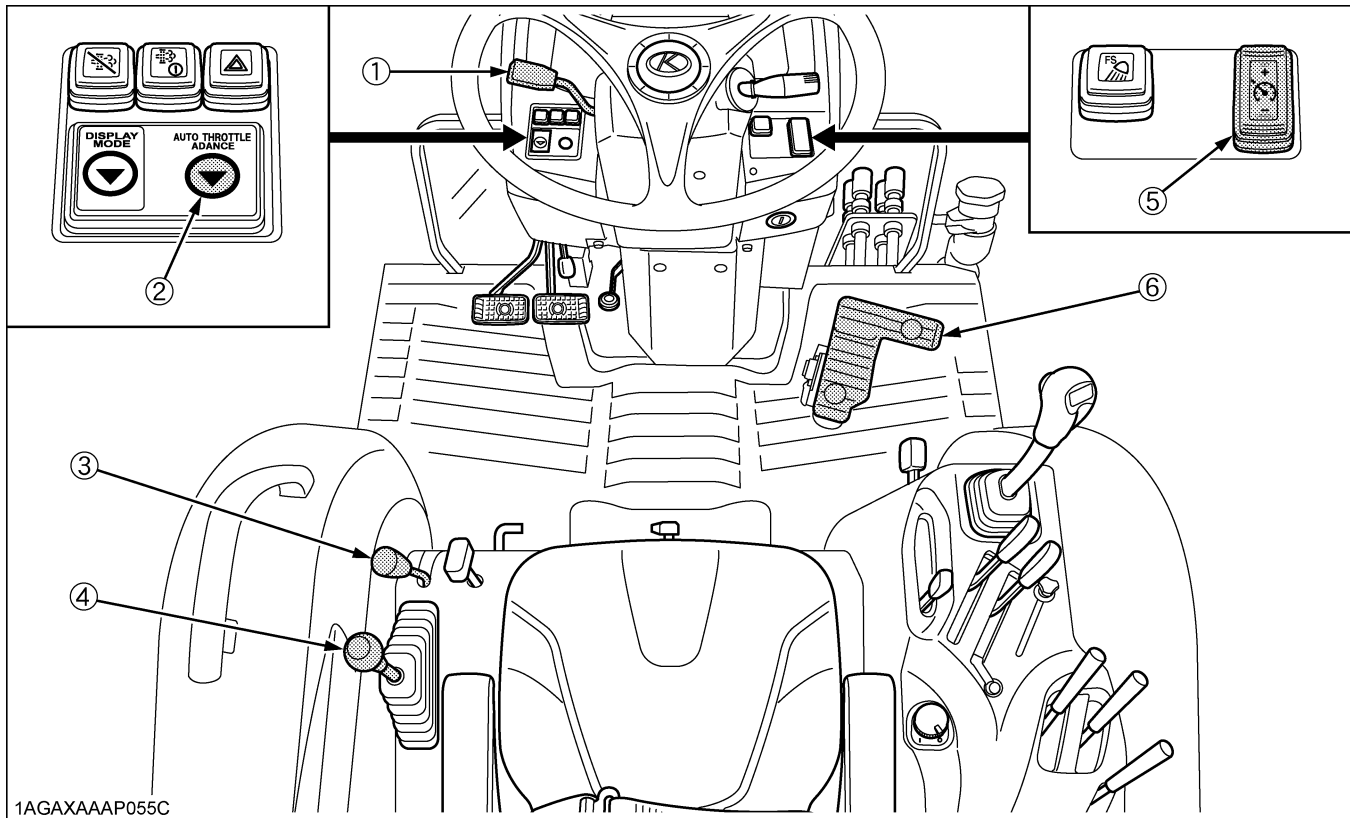

1AGAXAAP055C

- (1) H-DS lever
- (2) ATA switch
- (3) Front wheel drive lever
- (4) Range gear shift lever
- (5) Cruise control switch
- (6) Speed control pedal

■ HST Response Control

HST response control is used to set the start-up response when you step on the speed control pedal and the engine brake effect when you release the pedal.

Set the HST response control toward "FAST", and the response level gets quicker. Set it toward "SLOW" to have a slower response level.

When you move the tractor forward and backward repeatedly, during loader operations, for example, set the HST response control toward "FAST". It helps improve the working efficiency.

When using "STALL GUARD" with PTO powered implements, the tractor automatically adjust for optimum response.

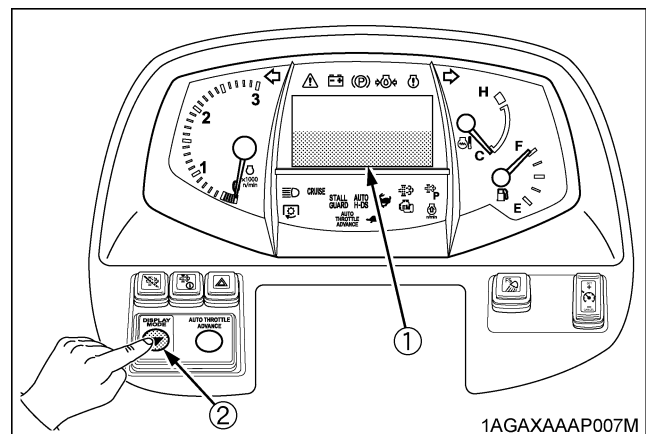

1AGAXAAP007M

- (1) IntelliPanel(TM) display
- (2) Display mode button

HST

GST

MT

HST Mode

"MANUAL", "STALL GUARD" or "AUTO H-DS/STALL GUARD" can be selected.

Choose the best mode according to the type of job or your operating style. The selected mode is displayed on the indicator on the meter panel.

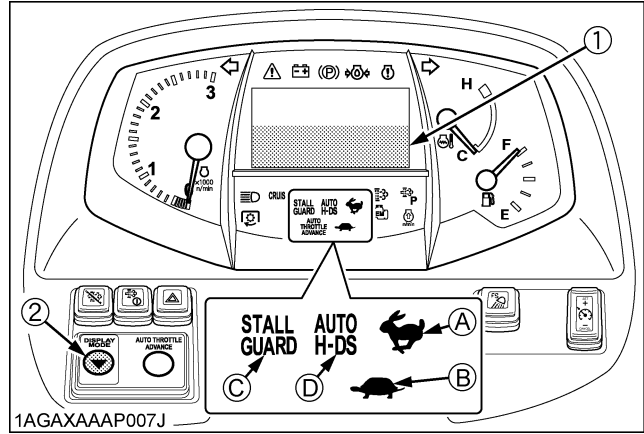

- (1) IntelliPanel(TM) display
- (2) Display mode button
- (A) "↑" (Hi)
- (B) "↓" (Lo)
- (C) "STALL GUARD"
- (D) "AUTO H-DS"

◆ Setting procedure

1. Press the Display mode button to select the display (A).
2. Hold down the Display mode button to highlight "HST MODE []".
3. Hold down the Display mode button to switch to the display (B).
4. Each time the Display mode button is pressed, and the STALL GUARD and AUTO H-DS modes are differently combined. Choose your desired combination.
5. Hold down the Display mode button, and the setting is made and the display (A) is resumed.

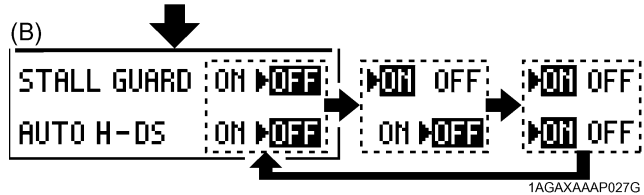
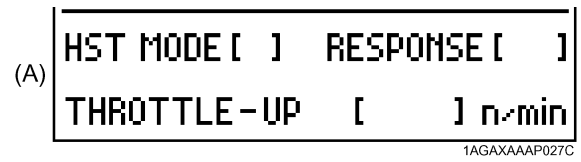

◆ STALL GUARD

1. The "STALL GUARD" indicator lights up on the meter panel.
2. If the tractor gets overloaded and the engine rpm drops, the tractor automatically slows down in response to the load, which prevents an engine stall.
3. When using PTO driven implements and the tractor is in "STALL GUARD" mode, the tractor speed will automatically adjust with the loads on the engine.

◆ AUTO H-DS/STALL GUARD

1. The "STALL GUARD" and "AUTO H-DS" indicators light up on the meter panel.
2. Set the H-DS lever to the "UP" (Hi) position. Make sure the "↑" (Hi) lamp lights up on the meter panel.
3. When using PTO driven implements and the tractor is in "STALL GUARD" mode, the tractor speed will automatically adjust with the loads on the engine.
4. If the tractor gets overloaded and the engine rpm drops, the tractor automatically slows down to the (Lo) low speed range. In this case, the "↑" (Hi) lamp goes out and the "↓" (Lo) lamp lights up instead.

5. When the engine rpm has come up again, the tractor automatically speeds up from the (Lo) low speed range to the (Hi) high speed range. (The tractor speed increases to match the speed control pedal.) If the load is rather heavy and the engine rpm drops further, "STALL GUARD" will still prevent engine stall.

NOTE :

- When the H-DS lever is set at the "Lo" position, the "AUTO H-DS" system does not work. (If the "Lo" lamp stays up and the "AUTO H-DS" lamp is flashing, set the H-DS lever to the "Hi" position.)
- Even in the "AUTO H-DS/STALL GUARD" mode, the Hi-Lo speed change can be made with this lever. Return the lever to the "Hi" position when there is no more need to slow down.
- When "STALL GUARD" is on and the PTO is engaged, "STALL GUARD" switches to "STALL GUARD PLUS" mode.
"STALL GUARD PLUS" maintains engine speed at a higher rate.

◆ **MANUAL**

The "STALL GUARD" and "AUTO H-DS" indicators go out on the meter panel. This provides for manual mode.

In this mode, any automatic control in response to the load does not activate.

■ Throttle-Up Switch

The front loader up/down speeds and the forefront attachment operating speeds depend on the hydraulic pump oil amount that fluctuates in proportion to the engine rpm. Keep down this switch and move the Loader/Remote control valve lever.

This action increases the above speeds in response to the "Presetable engine rpm" discussed later. As a result, the loader's cycle time can be shortened for higher working efficiency.

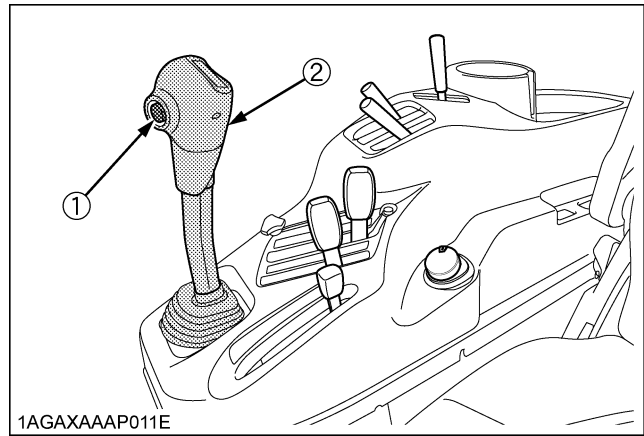

(1) Throttle-Up switch
(2) Loader / Remote control valve lever

HST

GST

MT

◆ Setting procedure

1. Press the Display mode button to select the display (A).
2. Hold down the Display mode button to highlight "HST MODE []".
3. Press the Display mode button to highlight "THROTTLE-UP [] n/min".
4. Hold down the Display mode button to switch to the display (B).
5. Press the Display mode button to move on to the next liquid crystal cell (black) to achieve a desired engine rpm.
6. Hold down the Display mode button, and the setting is made and the display (A) is resumed.

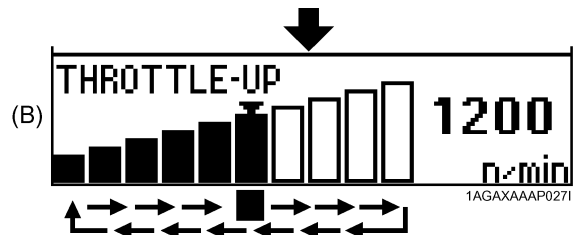
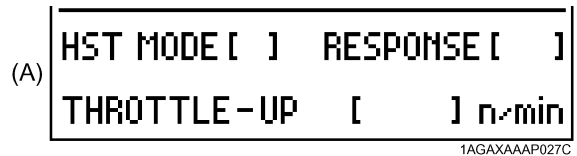

Range Gear Shift Lever (L-M-H)

The range gear shift can only be shifted when the tractor is completely stopped and the speed control pedal is in the neutral position.

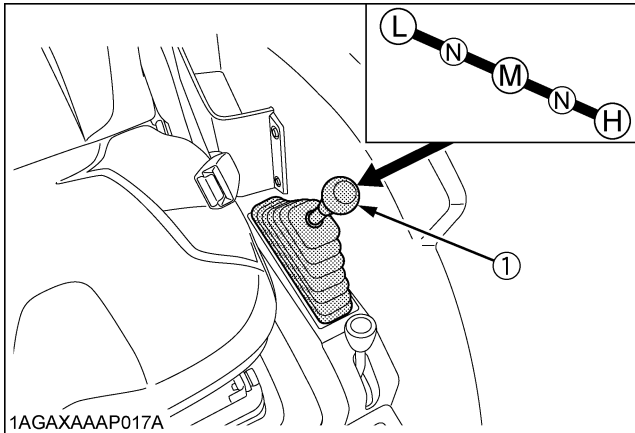

(1) Range gear shift lever (L-M-H) (H) "HIGH"
(M) "MIDDLE"
(L) "LOW"
(N) "NEUTRAL POSITION"

IMPORTANT:

To avoid transmission and shift linkage damage when shifting:

- Completely stop the tractor using the brake pedals.
- Do not force the range gear shift lever.
- If it is difficult to shift the lever into L, M, or H from neutral position:

On slopes be sure to set the parking brake before starting the procedure.

- (1) Slightly depress the speed control pedal to rotate the gears inside of the transmission.
- (2) Release the speed control pedal to the neutral position.
- (3) Wait for a moment and then shift the lever.

NOTE :

- The range gear shift number being selected appears on the display.

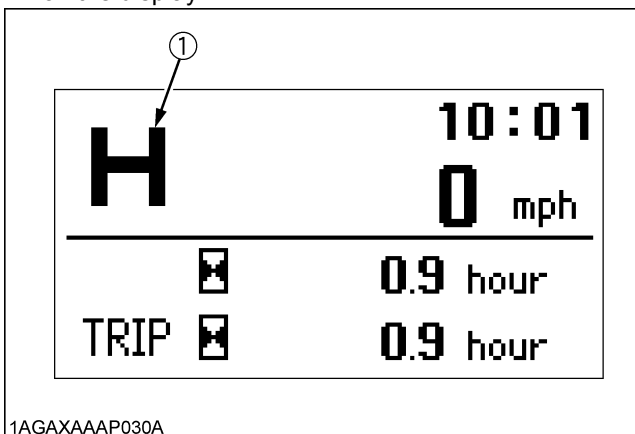

(1) Gear shift number (H-M-L) N: "NEUTRAL"

Front Wheel Drive Lever

WARNING

To avoid personal injury or death:

- Do not engage the front wheel drive when traveling at road speed.
- When driving on icy, wet or loose surfaces, make sure the tractor is correctly ballasted to avoid skidding and loss of steering control. Operate at reduced speed and engage front wheel drive.
- An accident may occur if the tractor is suddenly braked, such as by heavy towed loads shifting forward or loss of control.
- The braking characteristics are different between 2 and 4-wheel drive. Be aware of the difference and use carefully.

Use the lever to engage the front wheels with the tractor stopped. Shift the lever to "ON" to engage the front wheel drive.

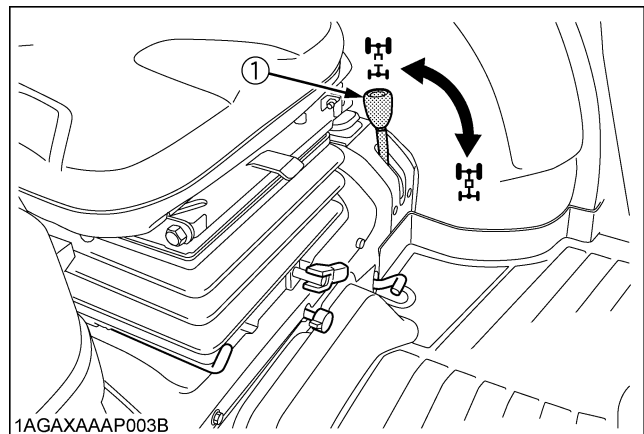

(1) Front wheel drive lever ON OFF

IMPORTANT :

- If the front wheel drive lever is difficult to set to OFF, stop the tractor, turn the steering wheel and move the lever.
- Tires will wear quickly if front wheel drive is engaged on paved roads.

Front wheel drive is effective for the following jobs:

1. When greater pulling force is needed, such as working in a wet field, when pulling a trailer, or when working with a front-end loader.
2. When working in sandy soil.
3. When working on a hard soil where a rotary tiller might push the tractor forward.
4. For increased braking at reduced speed.

HST

GST

MT

7. Accelerate the engine.

■ Hand Throttle Lever

Pulling the throttle lever back decreases engine speed, and pushing it forward increases engine speed.

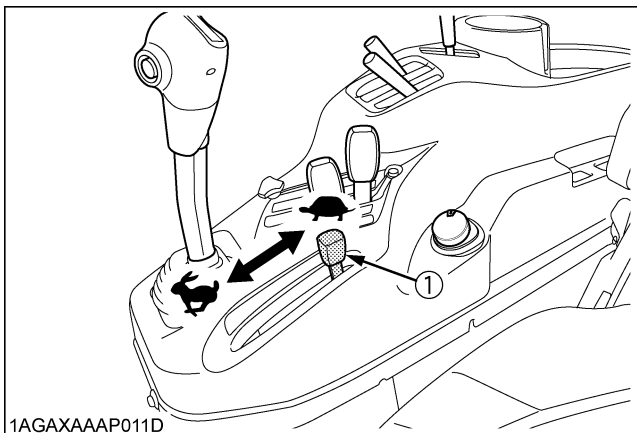

1AGAXAAP011D

(1) Hand throttle lever ↖ "INCREASE"
 ↗ "DECREASE"

8. Unlock the parking brake.

■ Parking Brake

To release the parking brake, depress the brake pedals again. When the parking brake is released, parking brake indicator in the Easy Checker(TM) goes off.

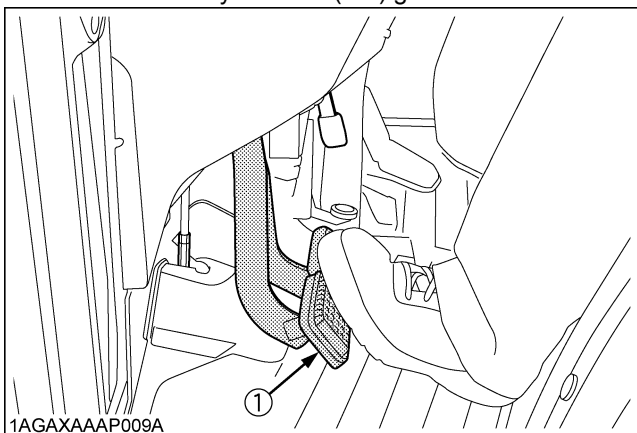

1AGAXAAP009A

(1) Brake pedals

9. Depress the Speed Control Pedal.

■ Speed Control Pedal

⚠ WARNING

To avoid personal injury or death:

- Do not operate if tractor moves on level ground with foot off of Speed Control Pedal.
- Consult your local KUBOTA Dealer.

Forward Pedal

Depress the speed control pedal with the toe of your right foot to move forward.

Reverse Pedal

Depress the speed control pedal with the heel or toe of your right foot to move backward.

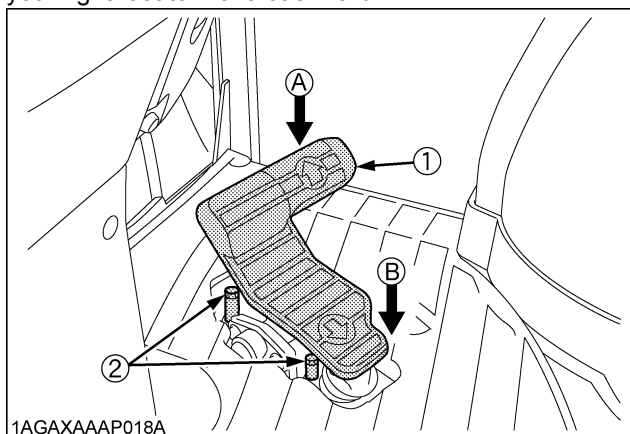

1AGAXAAP018A

(1) Speed control Pedal (A) "FORWARD"
 (2) Stopper bolt (B) "REVERSE"

IMPORTANT :

- To prevent serious damage to the HST, do not adjust the stopper bolts.

NOTE :

- When you stand up from the seat with the speed control pedal stepped on or the cruise control switch engaged (ON), the engine will stop regardless of whether the tractor is moving or not. This is because the tractor is equipped with Operator Presence Control system (OPC).

■ Cruise Control

⚠ WARNING

To avoid personal injury or death:

- Do not use the cruise control when driving on the road.
- Be sure to connect both the left and the right brakes when driving on the road. The speed cruise control won't be released with single brake activation.

Cruise control is designed for tractor operating efficiency and operator comfort. This device will provide a constant forward operating speed.

◆ To engage Cruise Control Device

1. Step on the Forward side of the Speed control pedal until a desired tractor speed is reached. With the pedal still down, push the front of the cruise control switch to the second level to set the cruise control.
2. To change the cruise speed setting, use the same switch. Each time its front is pressed, the cruise speed increases. Every time its back is pressed, the cruise speed decrease.
3. To operate faster than the set speed, depress the speed control pedal further down in this condition. The set speed will be resumed if you release the pedal.

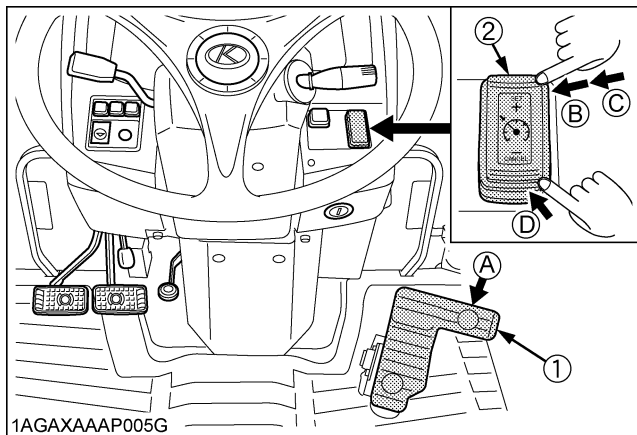

- (1) HST pedal
- (2) Cruise control switch
- (A) "FORWARD"
- (B) "SET"
- (C) "INCREASE"
- (D) "DECREASE"

NOTE :

- When the cruise control switch is used, the IntelliPanel(TM) display looks like below for about 10 seconds.

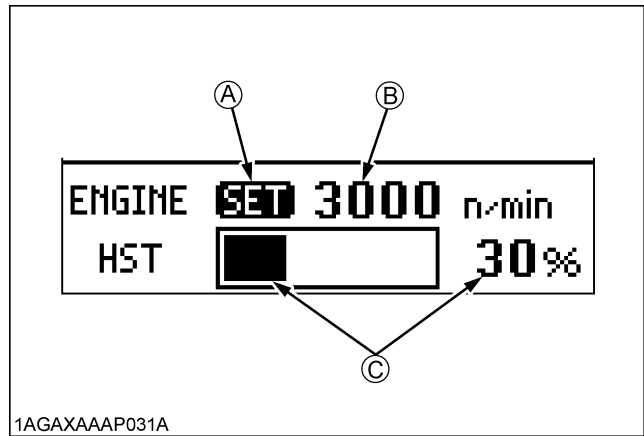

1AGAXAAP031A

- (A) "CRUISE SET"
- (B) "ENGINE RPM"
- (C) "Pedal step-on rate (travel enabling speed)"

◆ To disengage Cruise Control Device

- Press the rear half of the cruise control switch to the second step.
- Depress both brake pedals.
- Depress the speed control pedal in reverse.

NOTE :

- Cruise control will be disengaged automatically when both brake pedals are depressed.
- The cruise control device does not disengage when the individual right or left brake is applied.
- Cruise control device will not operate in reverse.

NOTE :

- When you stand up from the seat with the speed control pedal stepped on or the cruise control switch engaged (ON), the engine will stop regardless of whether the tractor is moving or not. This is because the tractor is equipped with Operator Presence Control system (OPC).

◆ IntelliPanel(TM) Message

1. The cruise control indicator stays on while the tractor is running under cruise control.

HST

GST

MT

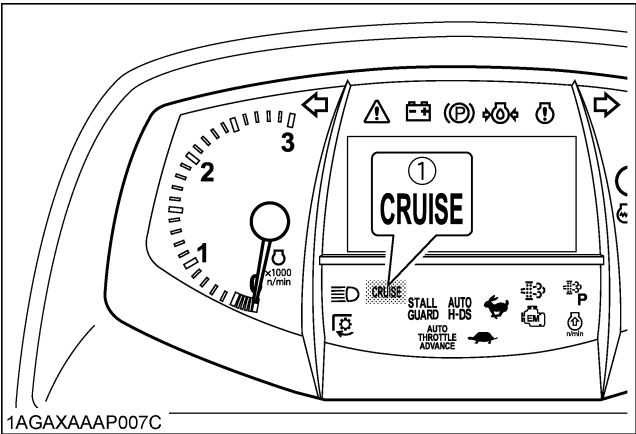

1AGAXAAP007C

(1) Cruise control indicator

2. Step on the speed control pedal until the tractor goes beyond the cruise speed. Now the indicator starts flashing.
3. It goes out when the cruise control is released with setting the cruise control switch to "OFF" or depressing the brake pedal or reverse pedal.

ATA (Auto Throttle Advance) Switch

When this switch is pushed, ATA indicator will come on, and the tractor speed and the engine rpm can be controlled with the speed control pedal. It helps pull a trailer or the like more easily.

Before pushing this switch, be sure to return the speed control pedal to "NEUTRAL" position.

Press the switch again, and the ATA indicator goes out. The ATA function turns off itself.

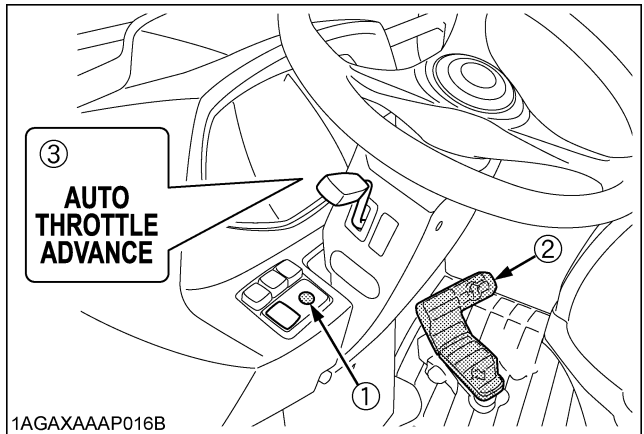

1AGAXAAP016B

- (1) ATA switch
- (2) Speed control pedal
- (3) ATA indicator

6. Selecting the Travel Speed.

[GST Type]

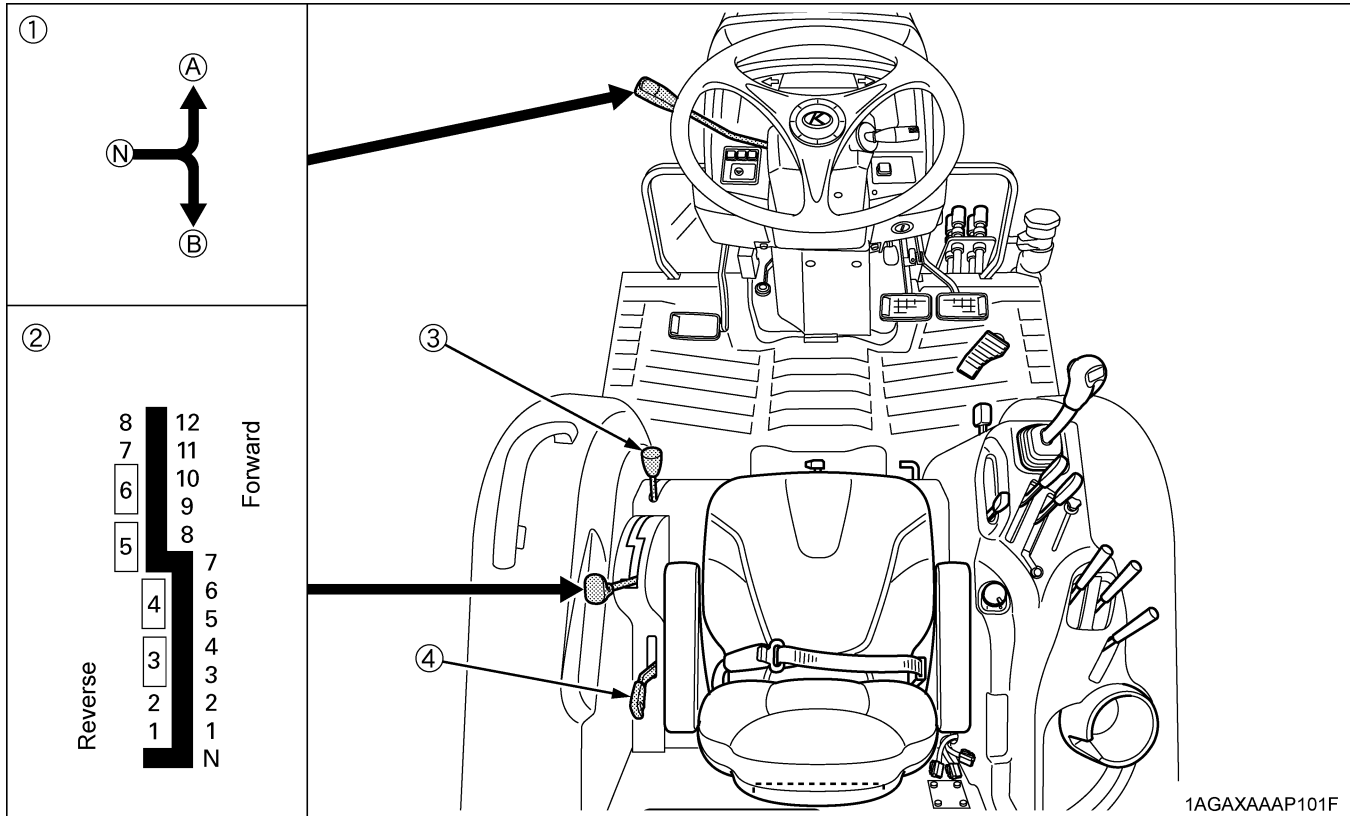

(1) Shuttle shift lever
(2) Main gear shift lever

(3) Front wheel drive lever
(4) Creep gear shift lever (if equipped)

(A) "FORWARD"
(B) "REVERSE"
(N) "NEUTRAL POSITION"

■ Shuttle Shift Lever



WARNING

To avoid personal injury or death:
BEFORE DISMOUNTING TRACTOR:

- **ALWAYS SET PARKING BRAKE**
Leaving transmission in gear with the engine stopped will not prevent tractor with GST transmission from rolling.
- **STOP THE ENGINE AND REMOVE THE KEY**

Raise up and shift the shuttle shift lever forward to obtain forward speeds and shift it backward to obtain reverse speeds without using the clutch pedal.

IMPORTANT :

- Reduce engine speed to low idle before shifting the shuttle shift lever.
- Shuttle shift change should not be done all at one time. Move the shuttle shift lever to the neutral position momentarily before you accomplish the shuttle change, hard or sudden gear shift may cause transmission damage.

NOTE :

- When you stand up from the seat with the shuttle lever at "FORWARD" or "BACKWARD", the engine will stop regardless of whether the tractor is moving or not. This is because the tractor is equipped with Operator Presence Control system (OPC).

1AGAXAAP101F

■ Main Gear Shift Lever

! WARNING

To avoid personal injury or death:

- Use the clutch when making an emergency stop or working in confined areas, such as getting tractor in position to attach an implement.
- An accident may occur with erratic shifting operation.
For safe operation, move main gear shift lever only one gear at a time.
- Shift the main gear shift lever firmly and without hesitation. Improper shift lever position will cause the tractor to momentarily coast on slopes.
- Avoid changing gears when climbing or descending a slope.
- Before ascending or descending a slope, shift to a gear low enough to control tractor speed without using brakes.
If you shift gears while ascending or descending a slope, be prepared to use the brakes to maintain control.
- Operate in reverse at slow speeds to maintain control.

By combination of using the main gear shift lever and the shuttle shift lever, 12 forward speeds and 8 reverse speeds are obtained.

With the Glide Shift Transmission, you can shift at any time, stopped or on-the-go. The Shuttle Shift lever must be in forward or reverse.

There is no need to use the clutch when starting out or shifting up or down.

Before dismounting tractor, shift the main gear shift lever and the shuttle lever to the neutral position and set parking brake.

IMPORTANT :

- Start in lower gears and shift one gear at a time until desired gear is obtained.
- To prolong clutch life, avoid slipping the hydraulic clutch. Pay attention to the following points:
 - Select proper gear and engine speed depending on the type of job.
 - Avoid lugging the engine, especially in higher gears. If RPM's drop excessively, shift to a lower gear.
- In cold climate, it may take longer for the tractor to move after the main shift lever is moved. This is because the transmission oil must warm up.
 - Warm up the tractor sufficiently. If there is not enough time to do so, start the tractor with the shuttle shift lever or the clutch.

- There is no problem with a delay in starting. The tractor will start as the oil temperature increases.

NOTE :

- 2 speed steps are assigned to each of the backward speed labels 3 thru 6. While using the main gear shift lever in this range for backward movement, however, each label gives just one speed, not two.

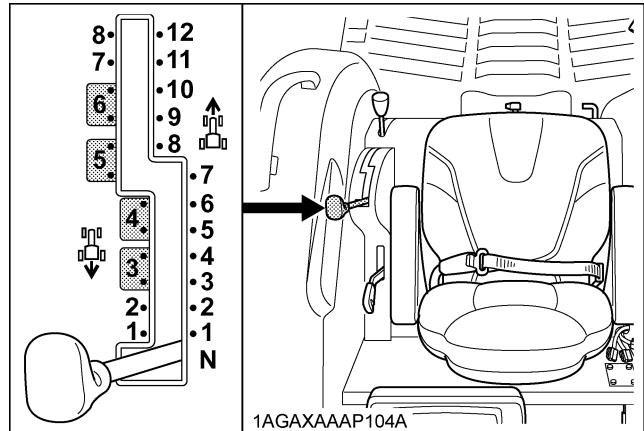

◆ IntelliPanel(TM) Message

The main gear shift number being selected appears on the display.

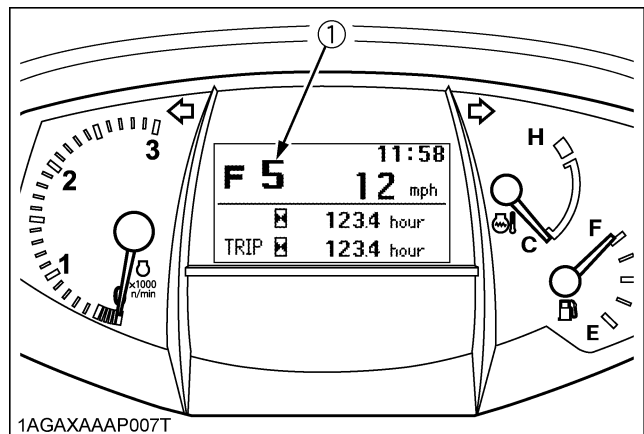

(1) Gear shift number (1 thru 12) N: "NEUTRAL"

HST

GST

MT

Creep Gear Shift Lever (if equipped)



WARNING

To avoid personal injury or death:

- When you leave the tractor, be sure to apply the parking brake and stop the engine.
- **IN APPLYING THE BRAKES:**
 - The torque of wheel axle is extremely high while creep speed is being used. Be sure to step down on the clutch pedal completely before applying the brakes, or they will not work.
 - When starting to operate the tractor, be sure to release the parking brakes. Misuse of the brakes may cause damage to the transmission and is therefore not acceptable to KUBOTA for coverage under the warranty.

Shift the creep gear shift lever at "○" to obtain high speeds and shift it "☺" to obtain low speeds. This shifting requires clutch operation.

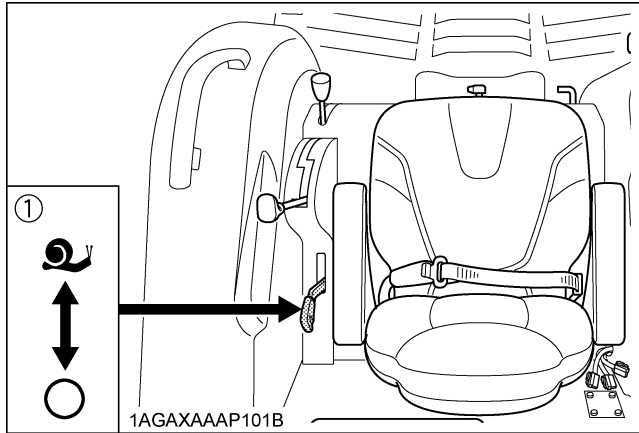

(1) Creep gear shift lever ☺ Creep ON
○ Creep OFF

◆ **Creep speed (attained by shifting the creep gear shift lever to "☺") should be used only when doing one of the following jobs:**

1. Deep rotary-tilling and harrowing
2. Planting
3. Turf application

◆ **Creep speed can not be used for any of the following:**

1. Pulling a trailer
2. Front-loader operation
3. Front-blade operation
4. Earth-moving
5. Entering and leaving a field
6. Loading onto and unloading from a truck

IMPORTANT :

- Press the clutch pedal completely down and stop the tractor's motion before shifting the creep gear shift lever.

Front Wheel Drive Lever



WARNING

To avoid personal injury or death:

- Do not engage the front wheel drive when traveling at road speed.
- When driving on icy, wet or loose surfaces, make sure the tractor is correctly ballasted to avoid skidding and loss of steering control. Operate at reduced speed and engage front wheel drive.
- An accident may occur if the tractor is suddenly braked, such as by heavy towed loads shifting forward or loss of control.
- The braking characteristics are different between 2 and 4-wheel drive. Be aware of the difference and use carefully.

Use the lever to engage the front wheels with the tractor stopped. Shift the lever to "ON" to engage the front wheel drive.

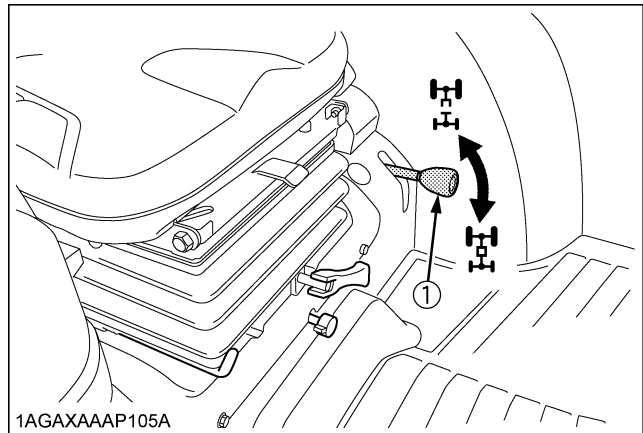

(1) Front wheel drive lever ☺ "ON" ☺ "OFF"

IMPORTANT :

- Depress the clutch pedal before engaging the front wheel drive lever.
- If the front wheel drive lever is difficult to set to OFF, stop the tractor, turn the steering wheel and move the lever.
- Tires will wear quickly if front wheel drive is engaged on paved roads.

◆ **Front wheel drive is effective for the following jobs:**

1. When greater pulling force is needed, such as working in a wet field, when pulling a trailer, or when working with a front-end loader.
2. When working in sandy soil.
3. When working on a hard soil where a rotary tiller might push the tractor forward.
4. For increased braking at reduced speed.

7. Accelerate the engine.

■ **Hand Throttle Lever**

Pulling the throttle lever back decreases engine speed, and pushing it forward increases engine speed.

■ **Foot Throttle**

Use the foot throttle when traveling on the road. Press down on it for higher speed. The foot throttle is interlocked with the hand throttle lever; when using the foot throttle, keep the hand throttle lever in low idling position.

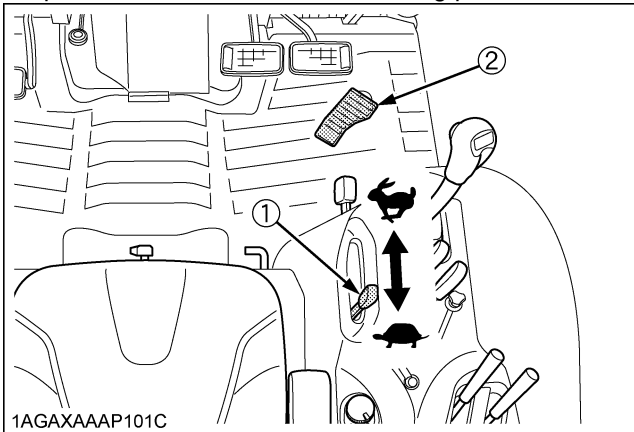

(1) Hand throttle lever
(2) Foot throttle

☞ "INCREASE"
☞ "DECREASE"

8. Unlock the parking brake and slowly release the clutch.

■ **Parking Brake**

To release the parking brake, depress the brake pedals again. When the parking brake is released, parking brake indicator in the Easy Checker(TM) goes off.

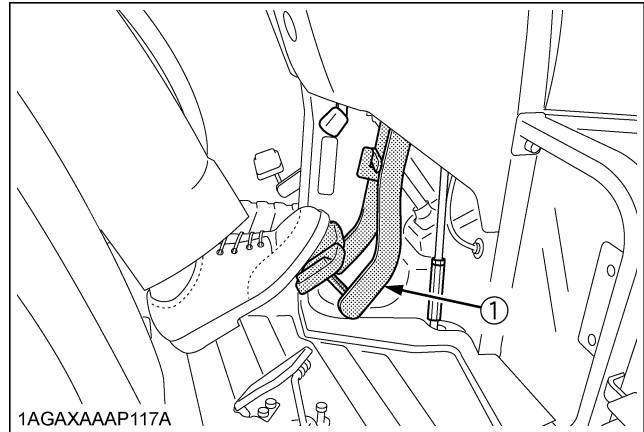

(1) Brake pedals

HST

GST

MT

6. Selecting the Travel Speed.

[Manual Transmission Type]

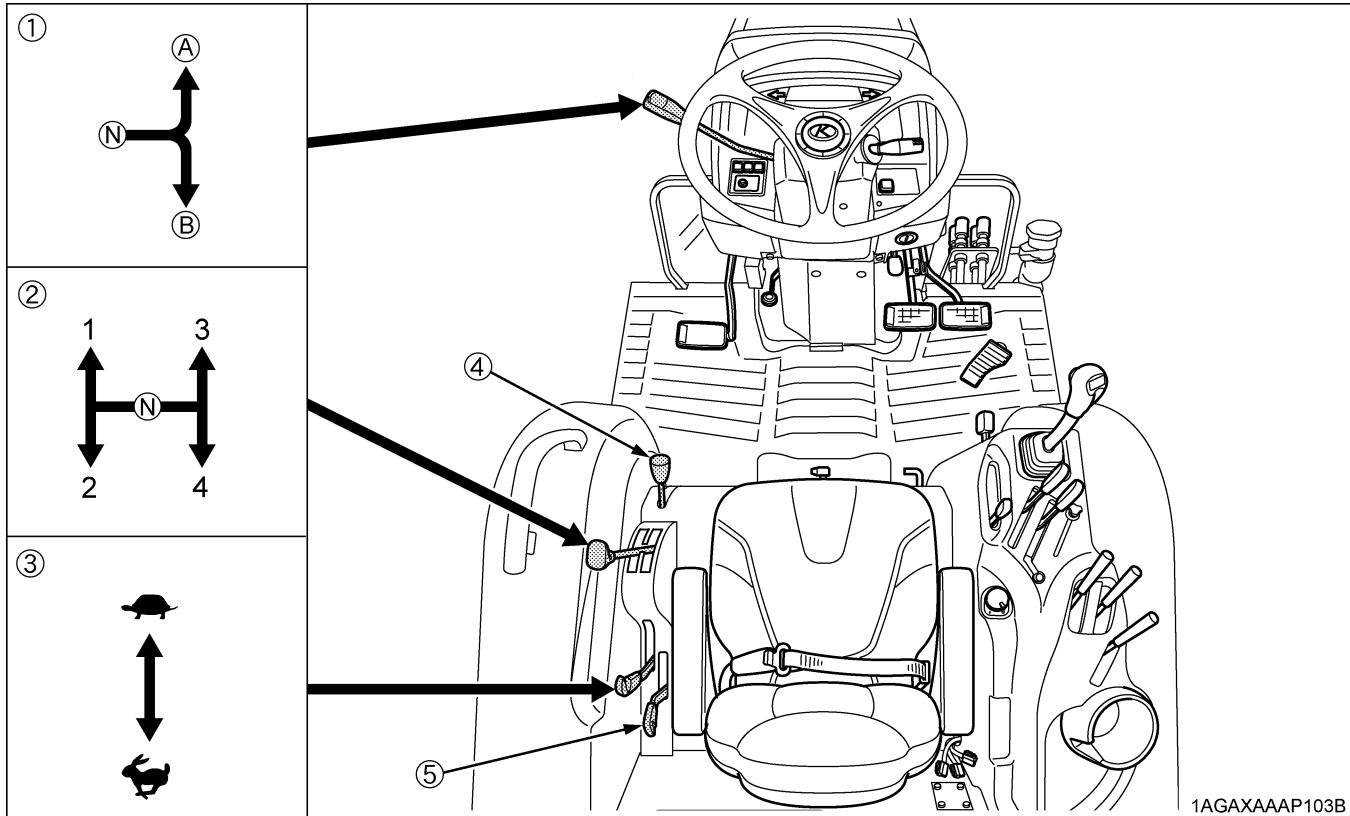

- | | | | |
|------------------------------------|--|------------------------|--------|
| (1) Synchro-shuttle shift lever | (4) Front wheel drive lever | (A) "FORWARD" | "HIGH" |
| (2) Main gear shift lever | (5) Creep gear shift lever (if equipped) | (B) "REVERSE" | "LOW" |
| (3) Range gear shift lever (Hi-Lo) | | (N) "NEUTRAL POSITION" | |

■ Main Gear Shift Lever

The main gear shift is fully synchronized to shift without stopping.

IMPORTANT :

- The main gear shift may be shifted between speeds on-the-go, but the clutch must be depressed.

■ Range Gear Shift Lever (Hi-Lo)

The range gear shift can only be shifted when the tractor is completely stopped and clutch is depressed.

IMPORTANT :

- To avoid transmission damage, depress the clutch pedal and stop tractor before shifting between ranges.

■ Synchro-Shuttle Shift Lever

Raise up and shift the shuttle shift lever forward to obtain forward speeds and shift back to obtain reverse speeds. This shifting requires clutch operation.

IMPORTANT :

- The synchro-shuttle shift lever may be shifted while the tractor is moving slowly and the clutch is depressed, but sudden gear shifting may cause transmission damage.

NOTE :

- When you stand up from the seat with the shuttle lever at "FORWARD" or "BACKWARD", the engine will stop regardless of whether the tractor is moving or not. This is because the tractor is equipped with Operator Presence Control system (OPC).

■ Creep Gear Shift Lever (if equipped)

! WARNING

To avoid personal injury or death:

- When you leave the tractor, be sure to apply the parking brake and stop the engine.
- IN APPLYING THE BRAKES:
 - The torque of wheel axle is extremely high while creep speed is being used. Be sure to step down on the clutch pedal completely before applying the brakes, or they will not work.
 - When starting to operate the tractor, be sure to release the parking brakes. Misuse of the brakes may cause damage to the transmission and is therefore not acceptable to KUBOTA for coverage under the warranty.

Shift the creep gear shift lever at "○" to obtain high speeds and shift it "☺" to obtain low speeds. This shifting requires clutch operation.

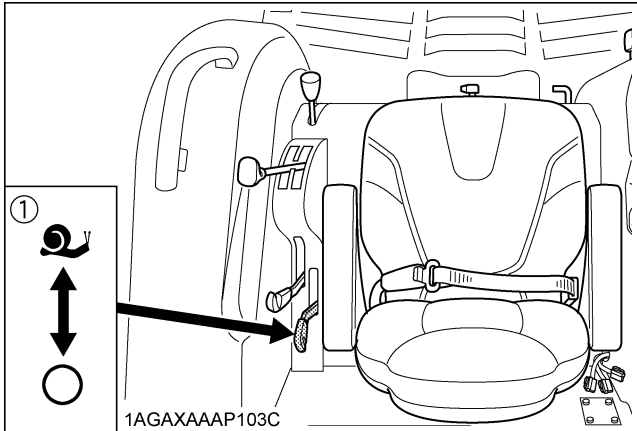

(1) Creep gear shift lever ☺ Creep ON
○ Creep OFF

◆ Creep speed (attained by shifting the creep gear shift lever to "☺") should be used only when doing one of the following jobs:

1. Deep rotary-tilling and harrowing
2. Planting
3. Turf application

◆ Creep speed can not be used for any of the following:

1. Pulling a trailer
2. Front-loader operation
3. Front-blade operation
4. Earth-moving
5. Entering and leaving a field
6. Loading onto and unloading from a truck

IMPORTANT :

- Press the clutch pedal completely down and stop the tractor's motion before shifting the creep gear shift lever.

■ Front Wheel Drive Lever

! WARNING

To avoid personal injury or death:

- Do not engage the front wheel drive when traveling at road speed.
- When driving on icy, wet or loose surfaces, make sure the tractor is correctly ballasted to avoid skidding and loss of steering control. Operate at reduced speed and engage front wheel drive.
- An accident may occur if the tractor is suddenly braked, such as by heavy towed loads shifting forward or loss of control.
- The braking characteristics are different between 2 and 4-wheel drive. Be aware of the difference and use carefully.

Use the lever to engage the front wheels with the tractor stopped. Shift the lever to "ON" to engage the front wheel drive.

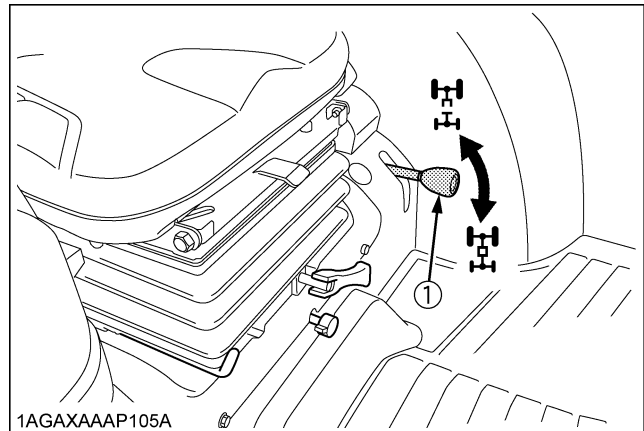

(1) Front wheel drive lever ☺ "ON" ☻ "OFF"

IMPORTANT :

- Depress the clutch pedal before engaging the front wheel drive lever.
- If the front wheel drive lever is difficult to set to OFF, stop the tractor, turn the steering wheel and move the lever.
- Tires will wear quickly if front wheel drive is engaged on paved roads.

◆ **Front wheel drive is effective for the following jobs:**

1. When greater pulling force is needed, such as working in a wet field, when pulling a trailer, or when working with a front-end loader.
2. When working in sandy soil.
3. When working on a hard soil where a rotary tiller might push the tractor forward.
4. For increased braking at reduced speed.

7. Accelerate the engine.

■ **Hand Throttle Lever**

Pulling the throttle lever back decreases engine speed, and pushing it forward increases engine speed.

■ **Foot Throttle**

Use the foot throttle when traveling on the road. Press down on it for higher speed. The foot throttle is interlocked with the hand throttle lever; when using the foot throttle, keep the hand throttle lever in low idling position.

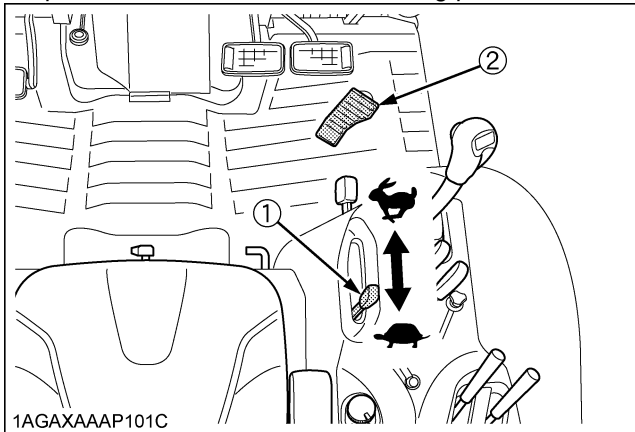

(1) Hand throttle lever
(2) Foot throttle

↖ "INCREASE"
↘ "DECREASE"

8. Unlock the parking brake and slowly release the clutch.

■ **Parking Brake**

To release the parking brake, depress the brake pedals again. When the parking brake is released, parking brake indicator in the Easy Checker(TM) goes off.

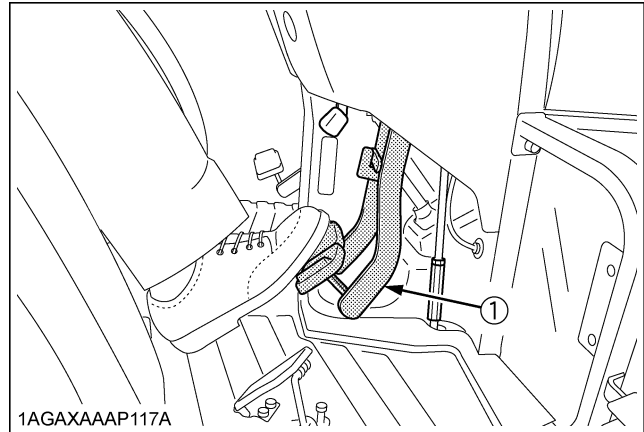

(1) Brake pedals

STOPPING

■ **Stopping**

1. Slow down the engine.
2. Step on the clutch and brake pedal.
3. After the tractor has stopped, disengage the PTO, lower the implement to the ground, shift the transmission to neutral, release the clutch pedal, and set the parking brake.

INTELLIPANEL (TM)

■ Changing Display Mode

1. Each time the display mode button is pressed, the IntelliPanel(TM) display mode changes from 1 thru 6 (Display 4 is HST type only). Select the display mode appropriate for the work in question.
2. When the key switch is set to "ON", the IntelliPanel(TM) will return to the last display mode used.

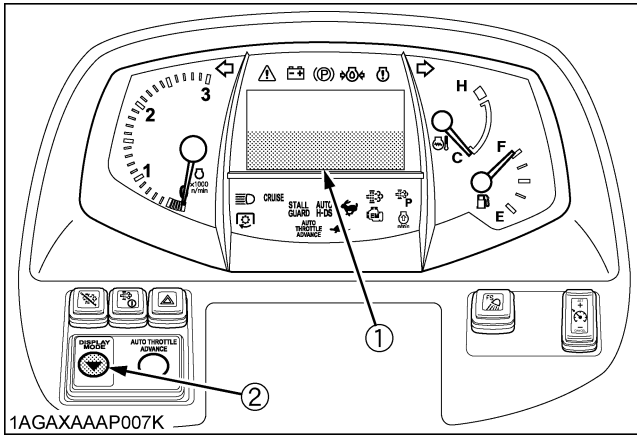

(1) IntelliPanel(TM) display
(2) Display mode button

Display 1: Hour meter / Trip meter mode 1AGAXAAP032A		<ul style="list-style-type: none"> ● [HOUR meter] Total operating hours are displayed. ● [TRIP meter] Total operating hours, counted from the previous resetting, is displayed. ● The hour meter indicates in 6 digits the hours the tractor has been used; the last digit indicates 1/10 of an hour. 	Reference page 60
Display 2: Fuel consumption mode 1AGAXAAP032B		<ul style="list-style-type: none"> ● Average fuel consumption is measured per hour from the previous resetting. ● Total fuel consumption is measured from the previous resetting. ● Hold down the Display mode button, and the setting is reset to "0". 	---
Display 3: PTO speed mode 1AGAXAAP032C		<ul style="list-style-type: none"> ● The PTO speed is displayed when the PTO clutch control switch is in "ON" position. ● When the PTO clutch control switch is in "OFF" position, "OFF" is displayed. 	69
Display 4: HST mode 1AGAXAAP032D		[HST type] <ul style="list-style-type: none"> ● The HST mode, Response and Throttle-UP settings get displayed. 	45 43 47
Display 5: PM buildup mode 1AGAXAAP032E		<ul style="list-style-type: none"> ● Displays the PM buildup inside the DPF muffler. ● Regeneration is needed when the 100% level has been reached. ● The more the bar is extended to the right, the more PM builds up. 	20
Display 6: Service inspect mode 1AGAXAAP032F		<ul style="list-style-type: none"> ● The time elapsed since the previous engine oil change gets displayed. 	61 62 103

NOTE :

- In cold weather the LCD meter response will normally be slower and the visibility be less, than in warmer weather.

HST

GST

MT

■ Resetting the Trip Meter and Setting the Clock

◆ Trip meter resetting procedure

1. Press the Display mode button to select the display (A).
2. Hold down the Display mode button to switch to the display (B).
3. Press the Display mode button to highlight "Clear".
4. Hold down the Display mode button, the display (A) is resumed and the trip meter reads "0.0".

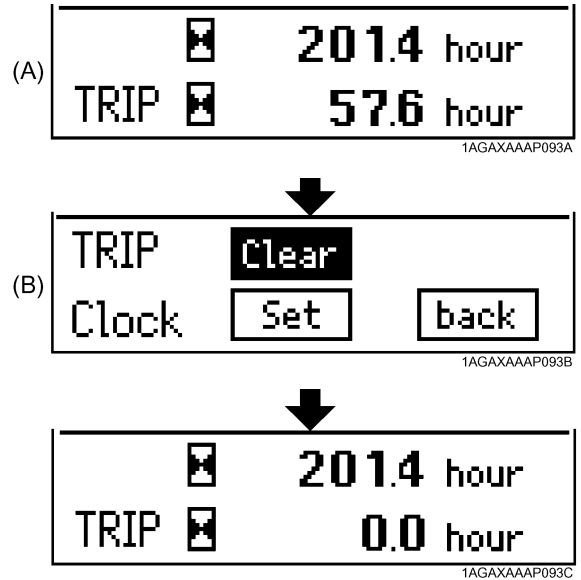

◆ Clock setting/displaying procedure

1. Press the Display mode button to select the display (A).
2. Hold down the Display mode button to switch to the display (B).
3. Press the Display mode button to highlight "Set"
4. Hold down the Display mode button to switch to the display (C).
5. Press the Display mode button to select "Adjust".

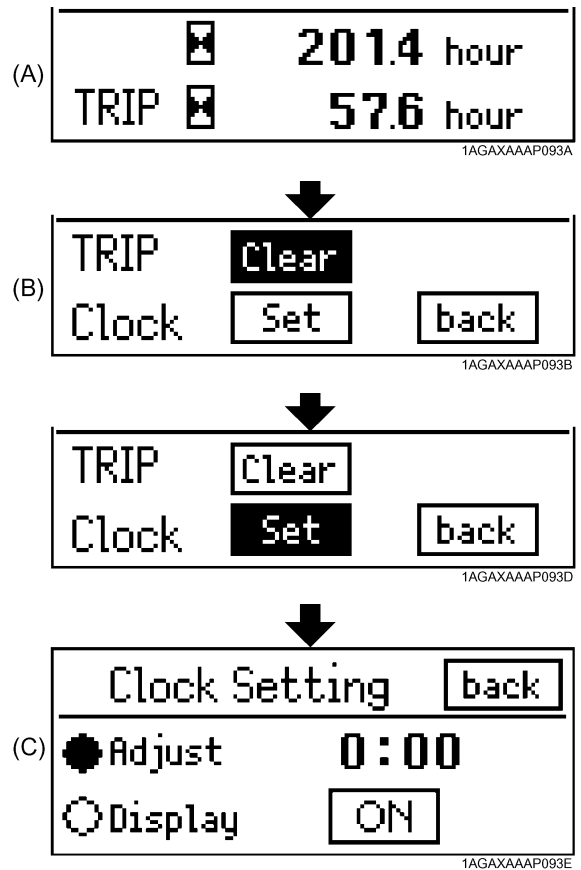

- 6. Hold down the Display mode button to highlight the "hour" digits of the clock. Press the Display mode button to enter a specified "hour".
Hold down the Display mode button to highlight the "minute" digits of the clock.
Press the Display mode button to enter a specified "minute". Hold down the Display mode button, and the display (C) is resumed.
- 7. Press the Display mode button to select "Display". Hold down the Display mode button to highlight the "ON" indication.
Each time the Display mode button is pressed, the "ON" and "OFF" indications are alternately switched. With "OFF" selected, the clock display disappears from the IntelliPanel(TM).
- 8. Hold down the Display mode button to get back to the display (C).
Press the Display mode button to highlight "back" and hold down the Display mode button to get back to the display (B).
Press the Display mode button to highlight "back" and hold down the Display mode button to get back to the display (A).

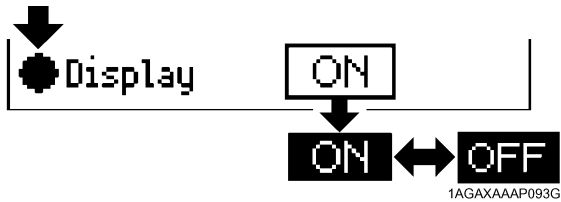
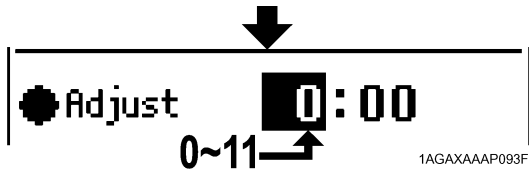

■SERVICE INSPECT mode displaying/ resetting procedure

- 1. Press the Display mode button to select the display (A).
- 2. Hold down the Display mode button to switch to the display (B).
- 3. Each time the Display mode button is pressed, the display items change one after another. Also the hours of an item that has reached the maintenance interval are highlighted.

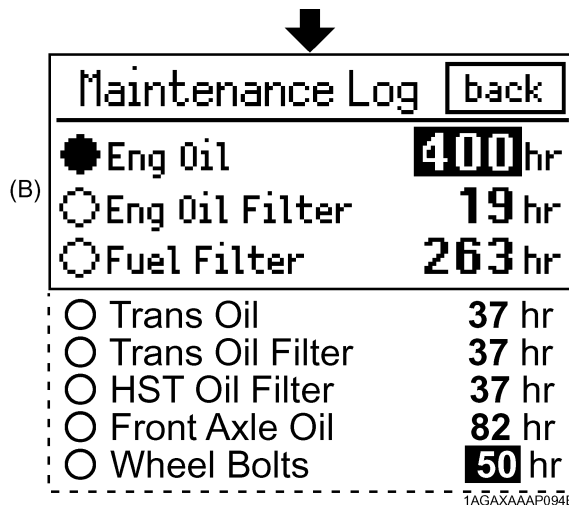
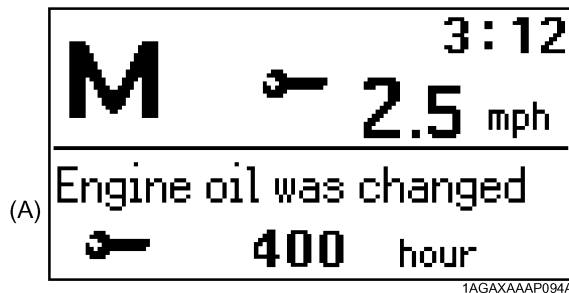

- With such item selected, hold down the Display mode button, and the hours are reset to zero.

- Press the Display mode button to highlight "back" and hold down the Display mode button to get back to the display (A).

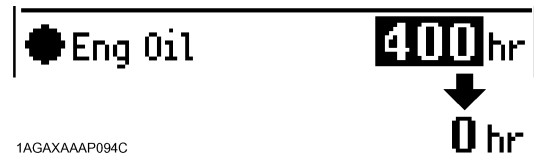

CHECK DURING DRIVING

■ IntelliPanel(TM) Message

If any of the following messages appears during operation, immediately stop the machine and follow the message's instructions. If the cause of trouble has not been pinpointed, consult your local KUBOTA Dealer.

◆ Engine over heat

If the engine gets overheated, the following message appears.

High temperature!
Engine slow down

1AGAXAAP035A

- Stop operation and set the engine to the idling speed.
- When the coolant temperature has dropped, the following message appears instead.

Stop engine
Check

1AGAXAAP036A

- Stop the engine, wait for 30 minutes until the machine cools down, and check the following points.
 - Check the reserve tank and radiator for cooling water shortage or leak.
 - Check the insect screening and radiator for chaff and dust deposits.
 - Check the fan belt for slack.

IMPORTANT :

- If steam gushes out of the reserve tank's overflow pipe, take the measure discussed above.

◆ SERVICE INSPECT

- The service inspect indicator shows up when the time for an engine oil change has come. Change the engine oil with fresh one.
(See "Changing Engine Oil" in "EVERY 400 HOURS" in "PERIODIC SERVICE" section.)
- After an engine oil change, reset the engine oil hour display to zero on the Maintenance Log screen in service inspect mode. The service inspect indicator goes out.
(See "SERVICE INSPECT mode displaying/resetting procedure" in "INTELLIPANEL(TM)" in "OPERATING THE TRACTOR" section.)

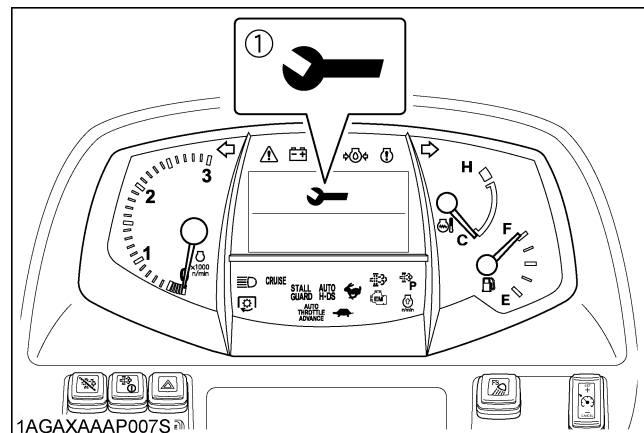

(1) Service inspect indicator

■ Immediately Stop the Engine if:

- The engine suddenly slows down or accelerates.
- Unusual noises are suddenly heard.
- Exhaust fumes suddenly become very dark.

Easy Checker(TM)

If the indicators in the Easy Checker(TM) come on during operation, immediately stop the engine, and find the cause as shown below.

Never operate the tractor while Easy Checker(TM) lamp is on.

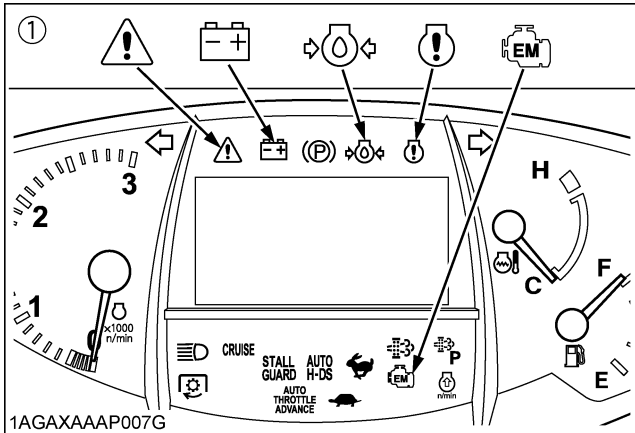

(1) Easy checker(TM)

Engine oil pressure

If the oil pressure in the engine goes below the prescribed level, the warning lamp in the Easy Checker(TM) will come on.

If this should happen during operation, and it does not go off when the engine is accelerated to more than 1000 rpm, check level of engine oil.

(See "Checking Engine Oil Level" in "DAILY CHECK" in "PERIODIC SERVICE" section.)

Electrical charge

If the alternator is not charging the battery, the Easy Checker(TM) will come on.

If this should happen during operation, check the electrical charging system or consult your local KUBOTA Dealer.

Engine warning

This indicator serves the following two functions. If the indicator lights up, pinpoint the cause and take a proper measure.

1. Error with the engine control system

If during operation the water temperature gauge reads an acceptable level but the warning lamp in the Easy Checker(TM) comes on, stop the engine and get it restarted. If the error happens again, consult your local KUBOTA Dealer.

IMPORTANT :

- If the warning indicator lights up, the following phenomena may appear depending on the engine's trouble spot.
 - The engine stops unexpectedly.

- The engine fails to start or gets interrupted just after start.
- The engine output is not enough.
- The engine output is enough, but the warning indicator stays on.

If the engine output is not enough, immediately interrupt the operation and move the tractor to a safe place and stop the engine.

2. Engine overheat

If the water temperature gauge reads an unusual level and the warning lamp in the Easy Checker(TM) comes on, the engine may have got overheated. Check the tractor by referring to "TROUBLESHOOTING" section.

Emission indicator

If this indicator lights up, take the steps to lower the water temperature. This helps keep the emission clean.

Master system warning

If trouble should occur at the engine, transmission or other control parts, the indicator flashes as a warning. If the trouble is not corrected by restarting the tractor, consult your local KUBOTA Dealer.

NOTE :

- For checking and servicing of your tractor, consult your local KUBOTA Dealer for instructions.

Fuel Gauge

A needle indicates the amount of fuel left regardless of the key position.

Be careful not to empty the fuel tank. Otherwise air may enter the fuel system.

Should this happen, the system should be bled. (See "Bleeding Fuel System" in "SERVICE AS REQUIRED" in "PERIODIC SERVICE" section.)

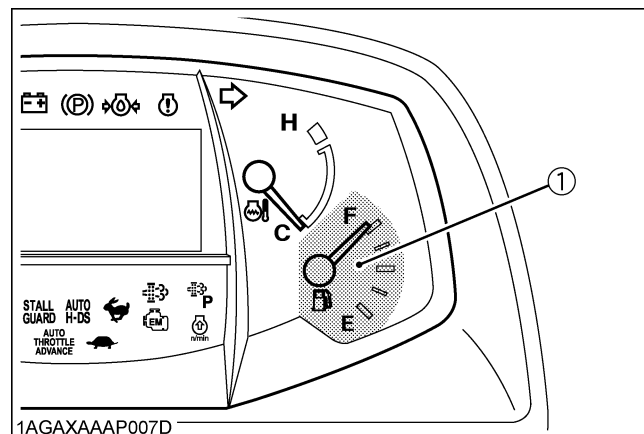

(1) Fuel gauge

(A) "FULL"
(B) "EMPTY"

NOTE :

- When the fuel has got shorter than 6 L (1.5 U.S.gals.) or so, the Fuel level indicator and the message appears on the IntelliPanel(TM).
If this should happen during operation, refuel as soon as possible. (See "Checking and Refueling" in "DAILY CHECK" in "PERIODIC SERVICE" section.)

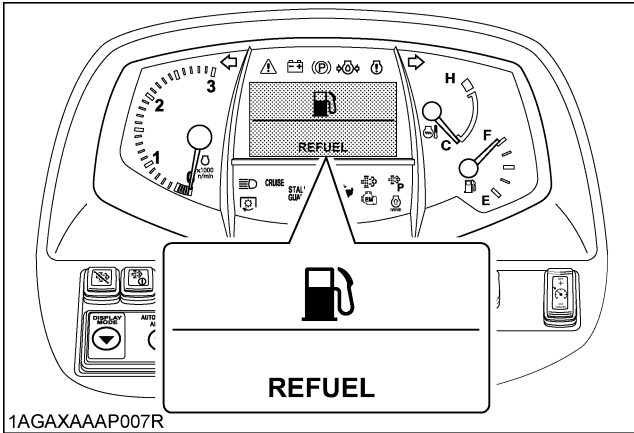

Coolant Temperature Gauge



WARNING

To avoid personal injury or death:

- Do not remove radiator cap until coolant temperature is well below its boiling point. Then loosen cap slightly to the stop to relieve any pressure before removing cap completely.

1. With the key switch at "ON", this gauge indicates the temperature of the coolant. "C" for "cold" and "H" for "hot".
2. If the indicator reaches the red zone position, engine coolant is overheated. Check the tractor by referring to "TROUBLESHOOTING" section.

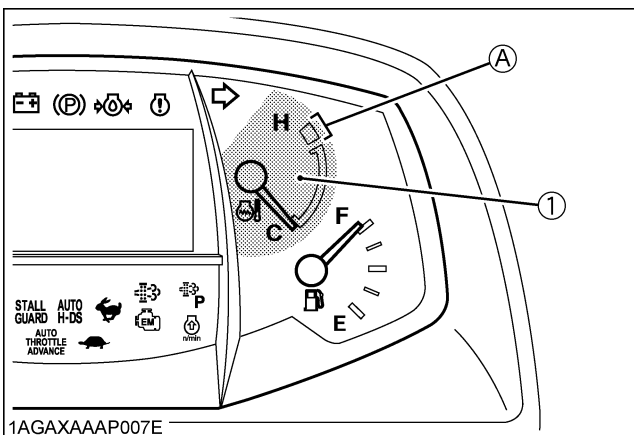

(1) Coolant temperature gauge (A) "RED ZONE"

Tachometer

The tachometer indicates the engine speed.

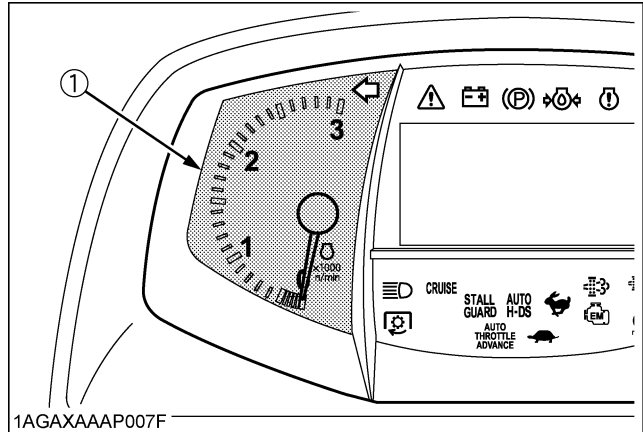

(1) Engine revolution

PARKING

Parking



WARNING

To avoid personal injury or death:
BEFORE DISMOUNTING TRACTOR

- ALWAYS SET PARKING BRAKE AND LOWER ALL IMPLEMENTS TO THE GROUND. Leaving transmission in gear with the engine stopped will not prevent tractor with GST and HST transmission from rolling.
- STOP THE ENGINE AND REMOVE THE KEY.

1. When parking, be sure to set the parking brake. To set the parking brake;
 - (1) Interlock the brake pedals.
 - (2) Depress the brake pedals.
 - (3) Latch the brake pedals with the parking brake lever.

[GST / Manual Transmission Type]

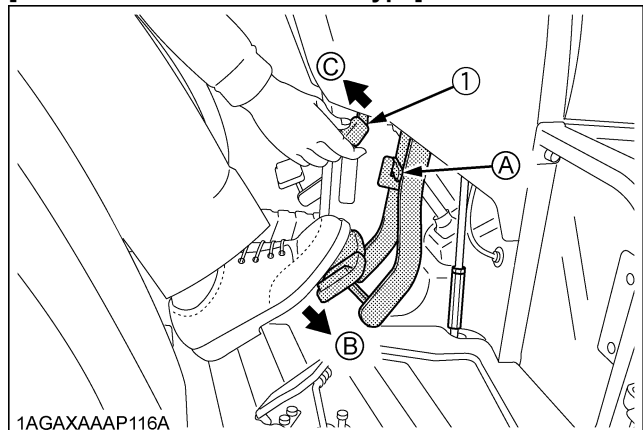

[HST Type]

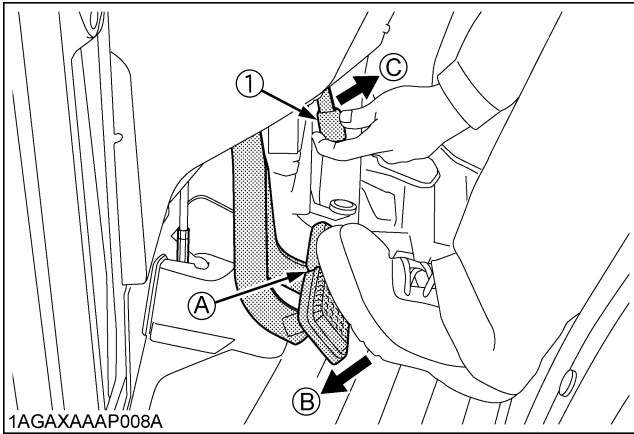

(1) Parking brake lever (A) Interlock the brake pedals
(B) "DEPRESS"
(C) "PULL"

IMPORTANT :

- To prevent damage to the parking brake lever, make sure that brake pedals are fully depressed before pulling the parking brake lever up.
2. Before getting off the tractor, disengage the PTO, lower all implements to the ground, place all control levers in their neutral positions, set the parking brake, stop the engine and remove the key.
 3. If it is necessary to park on an incline, be sure to chock the wheels to prevent accidental rolling of the machine.

OPERATING TECHNIQUES

■ Differential Lock



WARNING

To avoid personal injury or death due to loss of steering control:

- Do not operate the tractor at high speed with differential lock engaged.
- Do not attempt to turn with the differential lock engaged.
- Be sure to release the differential lock before making a turn in field conditions.

If one of the rear wheels should slip, step on the differential lock pedal. Both wheels will turn together, then reduce slippage.

Differential lock is maintained only while the pedal is depressed.

[GST / Manual Transmission Type]

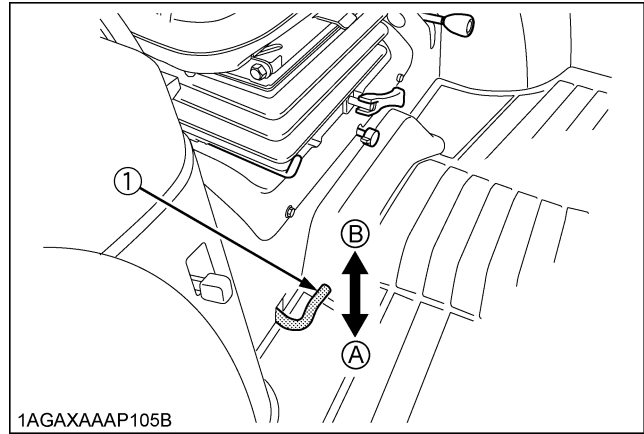

[HST Type]

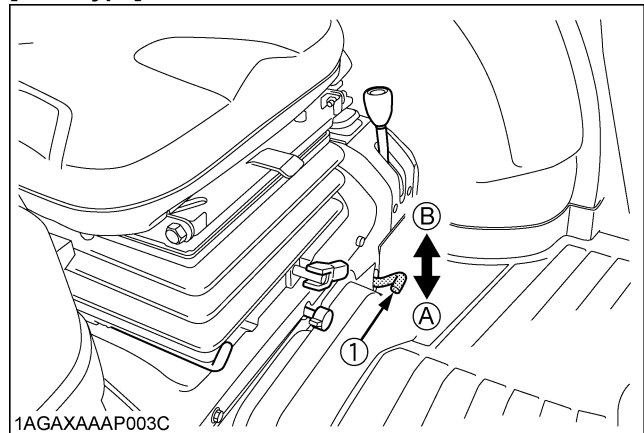

(1) Differential lock pedal (A) Press to "ENGAGE"
(B) Release to "DISENGAGE"

IMPORTANT :

- When using the differential lock, always slow the engine down.
- To prevent damage to power train, do not engage differential lock when one wheel is spinning and the other is completely stopped.
- If the differential lock cannot be released, step lightly on the brake pedals alternately.

■ Operating the Tractor on a Road



WARNING

To avoid personal injury or death:

- To help assure straight line stops when driving at transport speeds, lock the brake pedals together. Uneven braking at road speeds could cause the tractor to roll-over.
- When traveling on road with 3-point hitch mounted implement attached, be sure to have sufficient front weight on the tractor to maintain steering ability.

Be sure SMV emblem and warning lamps are clean and visible. If towed or rear-mounted equipment obstructs these safety devices, install SMV emblem and warning lamps on equipment.

Consult your local KUBOTA Dealer for further details.

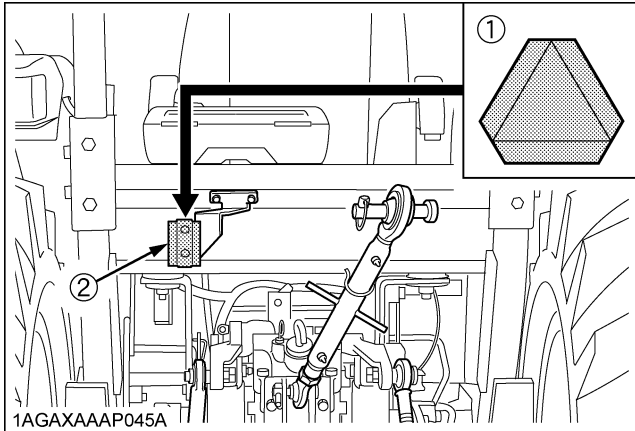

(1) SMV emblem

(2) Bracket

Operating on Slopes and Rough Terrain



WARNING

To avoid personal injury or death:

- Always back up when going up a steep slope. Driving forward could cause the tractor to tip over backward. Stay off hills and slopes too steep for safe operation.
- Avoid changing gears when climbing or descending a slope.
- If operating on a slope, never disengage the clutch or shift levers to neutral. Doing so could cause loss of control.
- Do not drive the tractor close to the edges of ditches or banks which may collapse under the weight of the tractor. Especially when the ground is loose or wet.

1. Be sure wheel tread is adjusted to provide maximum stability.
(See "WHEEL ADJUSTMENT" in "TIRES, WHEELS AND BALLAST" section.)
2. Slow down for slopes, rough ground, or sharp turns, especially when transporting heavy, rear mounted equipment.
3. Before descending a slope, shift to a gear low enough to control speed without using brakes.

Transport the Tractor Safely

1. The tractor, if damaged, must be carried on a truck. Secure the tractor tightly with ropes.
2. Follow the instruction below when towing the tractor: Otherwise, the tractor's powertrain may get damaged.
 - Set the all shift levers to "NEUTRAL" position.
 - If possible, start engine and select 2WD, if creep speed is fitted ensure that it is disengaged.
 - Tow the tractor using its front hitch or drawbar.
 - Never tow faster than "10 km/h (6.2 mph)".

Directions for Use of Power Steering

1. Power steering is activated only while the engine is running. Slow engine speeds make the steering a little heavier. While the engine is stopped, the tractor functions in the same manner as tractors without power steering.
2. When the steering wheel is turned all the way to the stop, the relief valve is activated. Do not hold the steering wheel in this position for a long period of time.
3. Avoid turning the steering wheel while the tractor is stopped, or tires may wear out sooner.
4. The power steering mechanism makes the steering easier. Be careful when driving on a road at high speeds.

Electrical Outlet

An electrical outlet is supplied for use with implement.

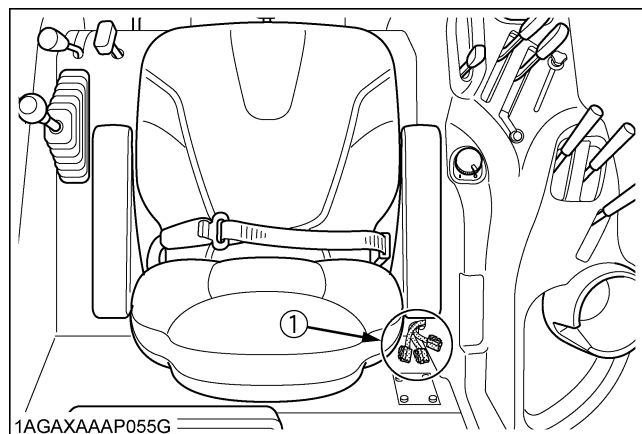

(1) Accessory electrical outlet (Total 10 A)

PTO

PTO OPERATION



WARNING

To avoid personal injury or death:

- Disengage PTO, stop engine, and allow all rotating components to come to a complete stop before connecting, disconnecting, adjusting, or cleaning any PTO driven equipment.

■ PTO Clutch Control Switch

1. The tractor has a 540 rpm speed position and 6-spline shaft.
2. The PTO clutch control switch engages or disengages the PTO clutch which gives the PTO independent control.

Turn the switch to "ON" to engage the PTO clutch. Turn the switch to "OFF" to disengage the PTO clutch.

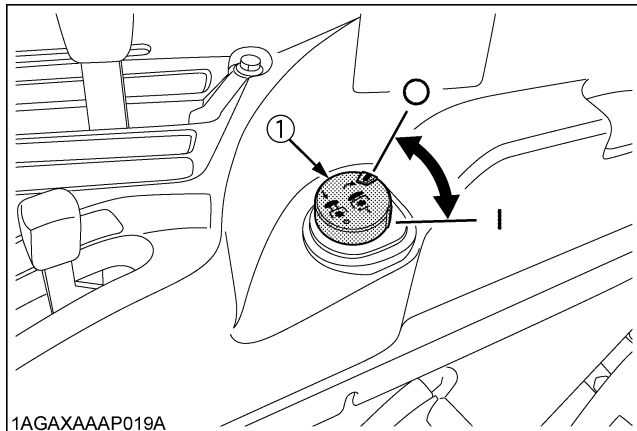

1AGAXAAP019A

(1) PTO clutch control switch | "ON" ○ "OFF"

◆ PTO Clutch Control Switch

To turn ON

While pushing the switch, turn clockwise to the " | " position and release your hand. (In the ON position, switch slightly rises itself.)

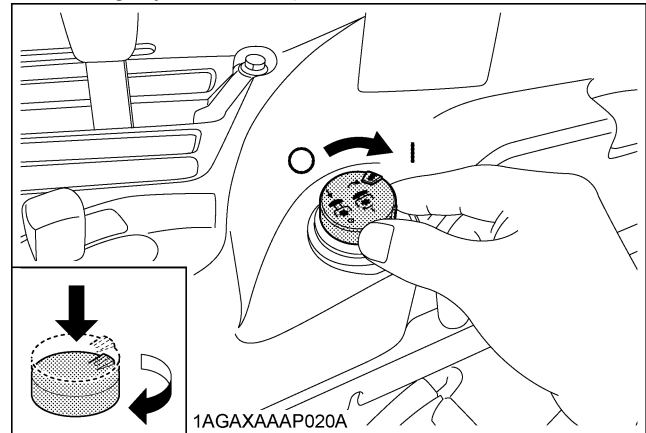

1AGAXAAP020A

To Turn OFF

Tap on top of the switch, and the switch will return to the OFF position.

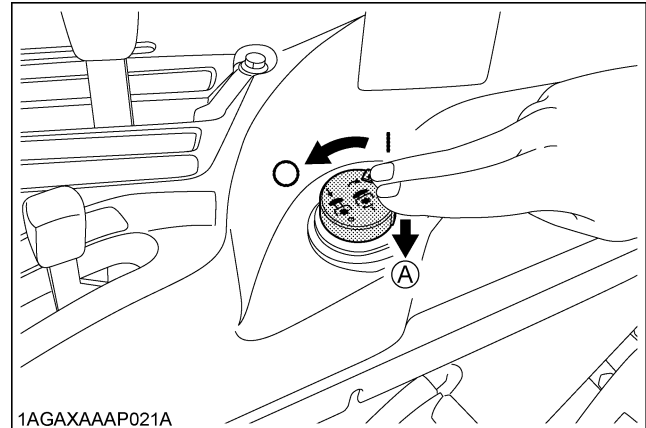

1AGAXAAP021A

(A) "PUSH"

IMPORTANT :

- To avoid shock loads to the PTO, reduce engine speed when engaging the PTO, then open the throttle to the recommended speed.
- To avoid damage of PTO clutch and implement, proper warm up is strongly recommended in cold weather.
Do not continuously turn the PTO clutch control switch.

Model		Engine Speed rpm	Shaft	PTO Speed rpm
GST Type Manual Transmission Type		2550	6-Spline	540
HST Type	L3560	2426		
	L4060 L4760	2476		
	L5460 L6060	2403		

NOTE :

- Tractor engine will not start if the PTO clutch control switch is in the engaged "ON" position.
- When the clutch pedal is depressed, the PTO engages. [GST, Manual Transmission Type]

Mid-PTO (if equipped)



WARNING

To avoid personal injury or death:

- Before operation, be sure to select the correct PTO lever position (mid/rear).
- Do not operate rear-PTO driven implements and mid-PTO driven implements at the same time except when the implements are specially designed to be used together.

To use mid-PTO, shift the mid-PTO lever to engaged position and turn the PTO clutch control switch to engaged position.

◆ **Mid-PTO lever**

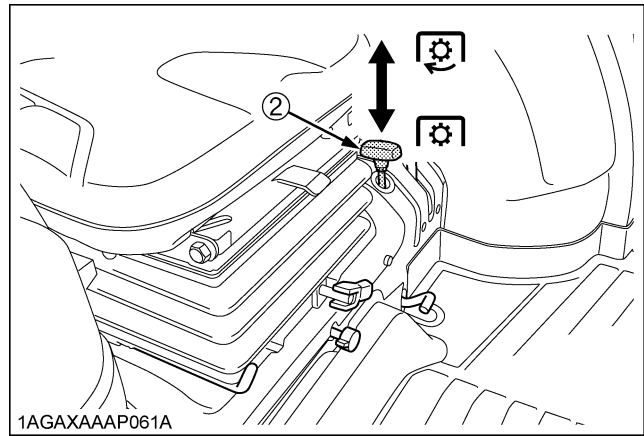

1AGAXAAP061A

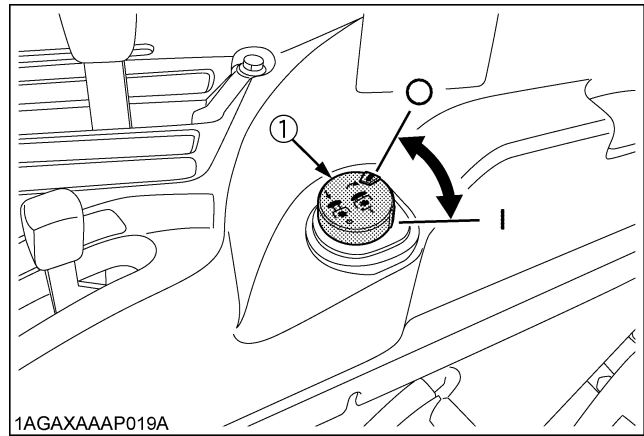

1AGAXAAP019A

- (1) PTO clutch control switch
- (2) Mid-PTO lever

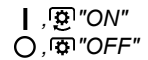

◆ **Rear and Mid-PTO speed**

PTO REVOLUTION (rpm)			
MID-PTO LEVER	PTO	PTO Clutch control switch	
		○ →	
	REAR	0	540
	MID	0	0
	REAR	0	540
	MID	0	2000

◆ **Mid PTO**

The mid PTO is available for KUBOTA approved implements.

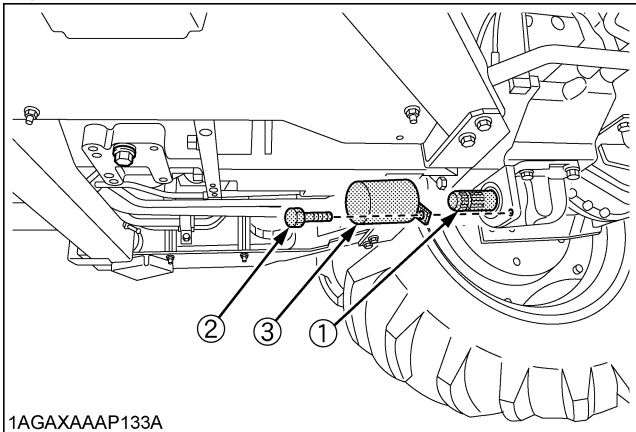

1AGAXAAP133A

- (1) Mid PTO
- (2) Bolt
- (3) PTO shaft cover

■ **Stationary PTO**

To park the tractor and use the PTO system (for chipper or pump, for example), start the PTO system in the following steps.

1. Apply the parking brakes and place blocks at the tires.
2. Make sure the shift levers are at NEUTRAL, and start the engine.
3. Tilt the operator's seat forward.
4. Set the PTO clutch control switch to engage "ON".

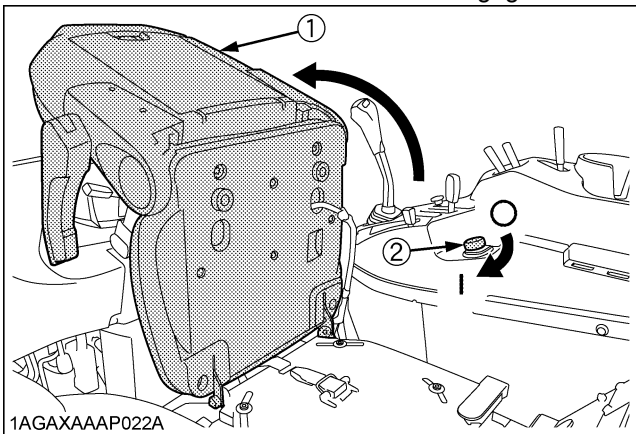

1AGAXAAP022A

- (1) Seat
 - (2) PTO clutch control switch
- ! "ON"
 ○ "OFF"

5. Set the engine speed to provide recommended rear PTO speed.

NOTE :

- If the PTO system is engaged and you stand up from the seat or the seat is not tilted forward, the engine stops automatically after standing up.

■ **IntelliPanel (TM) Message**

1. The PTO rpm can be checked in the display. (See "INTELLIPANEL(TM)" in "OPERATING THE TRACTOR" section.)
2. When the PTO system gets engaged (ON), the indicator lights up.

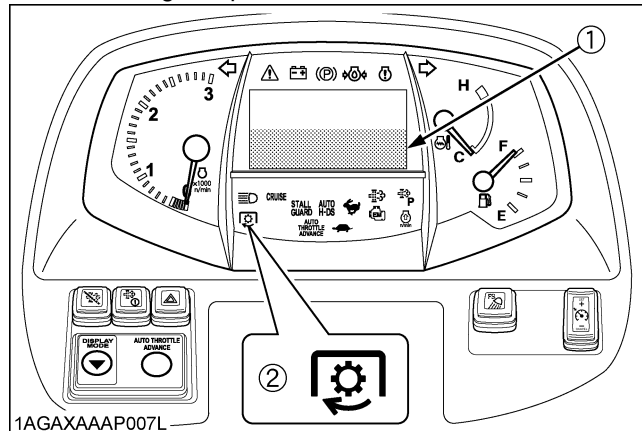

1AGAXAAP007L

- (1) Display
- (2) PTO indicator

NOTE :

- Rear PTO "ON"



1AGAXAAP037A

- Mid-PTO "ON"

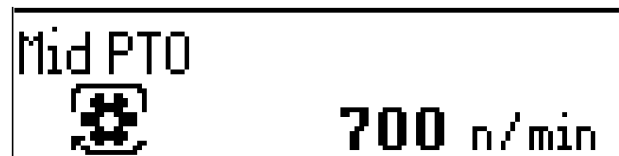

1AGAXAAP038A

■ PTO Shaft Cover and Shaft Cap

Keep the PTO shaft cover in place at all times.
Replace the PTO shaft cap when the shaft is not in use.
When connecting or disconnecting the joint to PTO shaft,
raise up the PTO shaft cover.

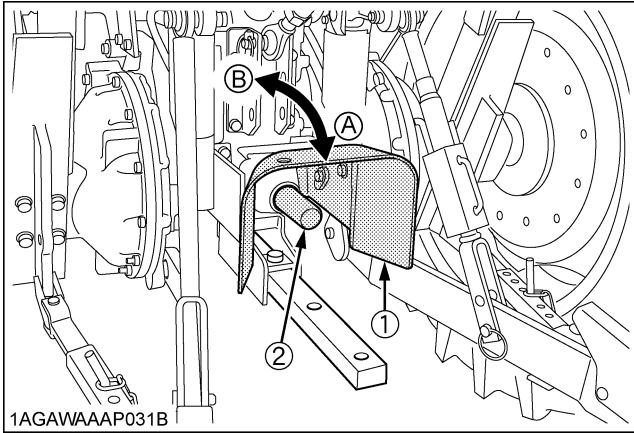

- (1) PTO shaft cover (A) "NORMAL POSITION"
(2) PTO shaft cap (B) "RAISED POSITION"

IMPORTANT :

- The universal joint of the PTO drive shaft is technically limited in its moving angle. Refer to the PTO Drive Shaft Instructions for proper use.

3-POINT HITCH & DRAWBAR

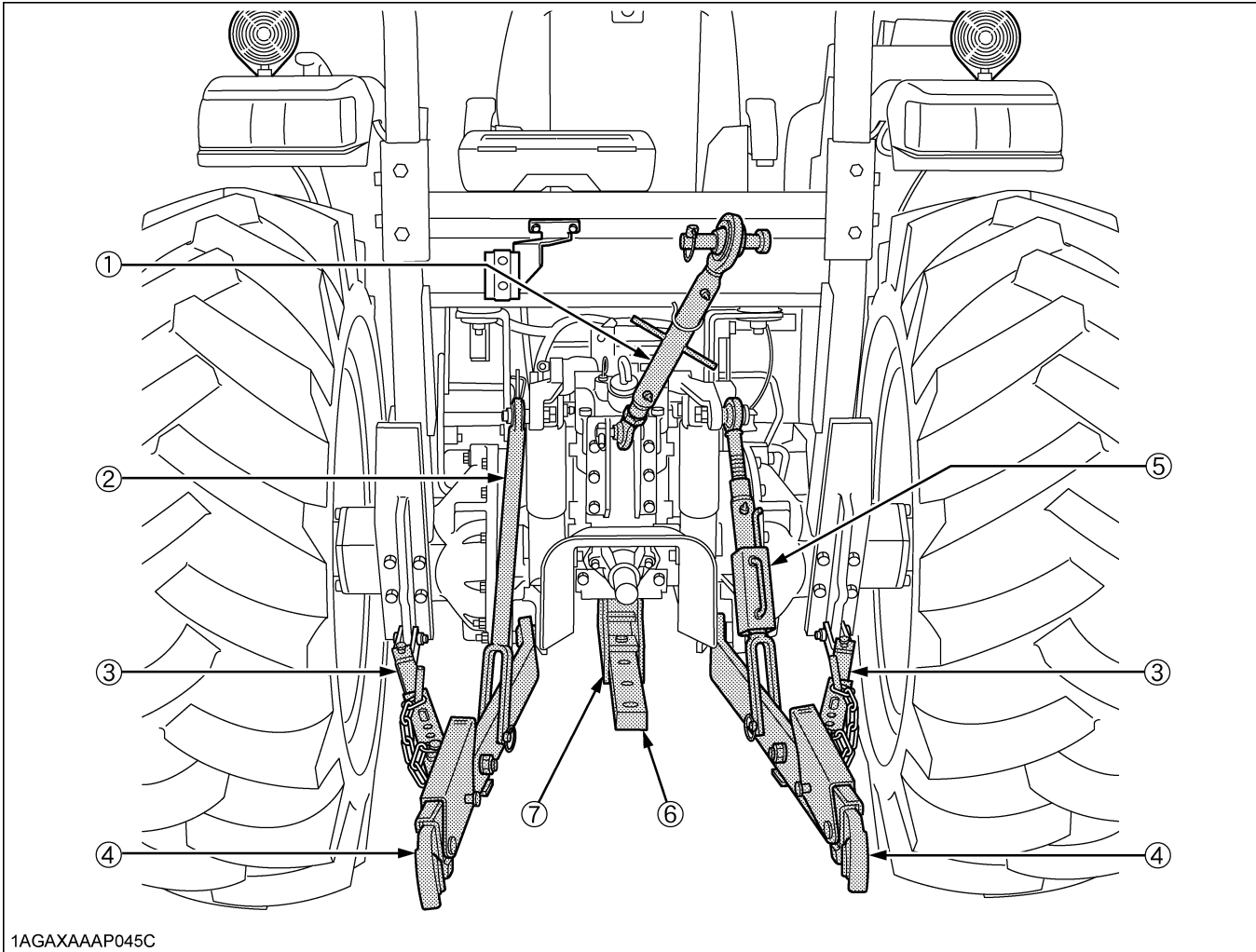

1AGAXAAP045C

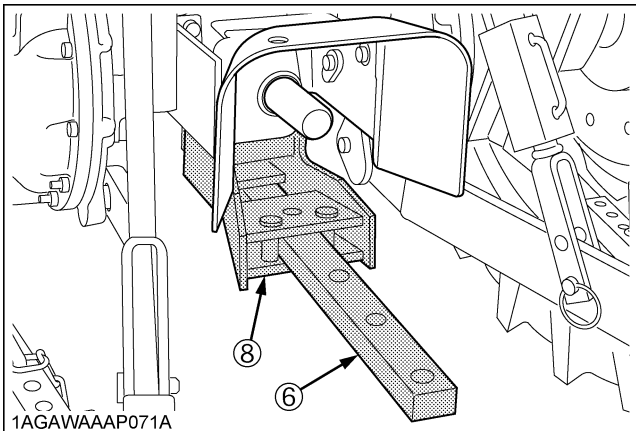

1AGAWAAP071A

- (1) Top link
- (2) Lifting rod (Left)
- (3) Telescopic stabilizers
- (4) Lower link
- (5) Lifting rod (Right)
- (6) Drawbar
- (7) Fixed drawbar frame
- (8) Swing drawbar frame [option]

3-POINT HITCH

1. Make preparations for attaching implement.

■ Category 1 & 2

L5060, L5460, L6060 have both category 1 & 2.

Category 1 type is standard and assemble all parts shown as below.

To change from category 1 to category 2.

1. Remove adjusting collar from the lower link.
2. Remove adjusting collar from the rear top link pin.
3. Use the correct rear top link pin for category 2.

[Category 1 type]

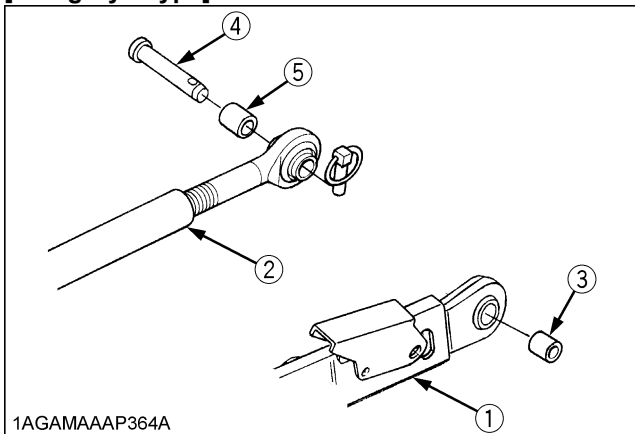

[Category 2 type]

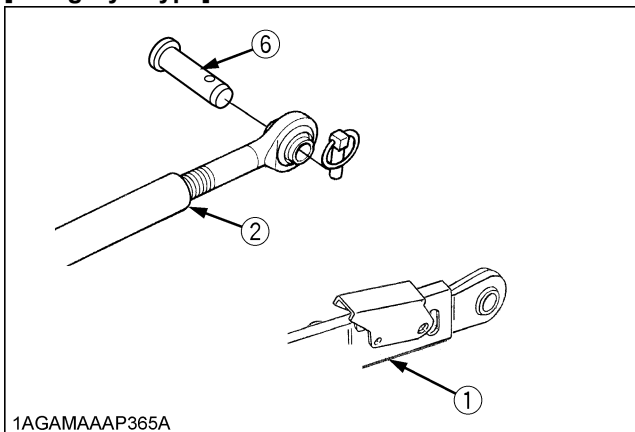

- | | |
|----------------------------|---------------------------|
| (1) Lower link | (4) Top link rear pin (1) |
| (2) Top link | (5) Collar, top link (1) |
| (3) Collar, lower link (1) | (6) Top link rear pin (2) |

■ Category 1

L3560, L4060, L4760 have category 1 only.

■ Selecting the top link mounting holes

Select the proper set of holes by referring to the "Hydraulic Control Unit Use Reference Chart" in "HYDRAULIC UNIT" section.

If the hydraulic unit is set for draft control, draft response is more sensitive when an implement is connected to the upper set of top link mounting holes. If draft control is not required, it is recommended to use the low set (4).

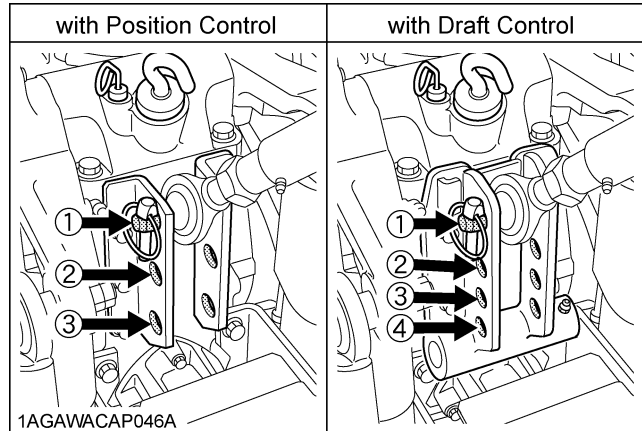

■ Drawbar

Remove the drawbar if a close mounted implement is attached.

2. Attaching and detaching implements

⚠ WARNING

To avoid personal injury or death:

- Be sure to stop the engine.
- Do not stand between tractor and implement unless parking brake is applied.
- Before attaching or detaching implement, locate the tractor and implement on a firm level surface.
- Whenever an implement or other attachment is connected to the tractor 3-point hitch, check full range of operation for interference, binding or PTO separation.

■ Lifting Rod (Right)



WARNING

To avoid personal injury or death:

- Do not extend lifting rod beyond the groove on the thread rod.

1. To adjust the length of the lifting rod, lift the adjusting handle and turn to desired length.
2. After adjusting, lower the lifting rod adjusting handle to the lock position.
3. When extending the rod using adjusting handle, do not exceed the groove on the rod thread.

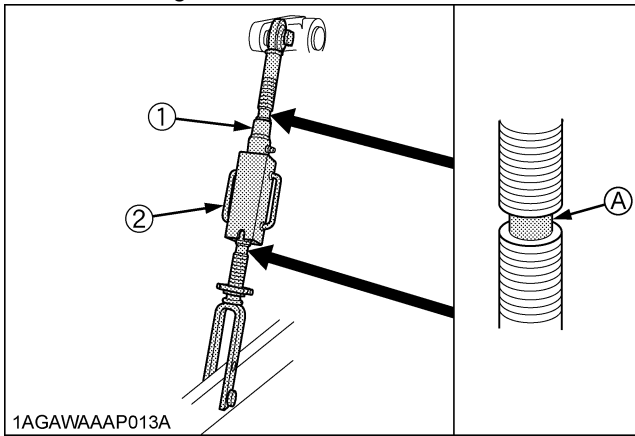

(1) Lifting rod
(2) Adjusting handle

(A) "GROOVE"

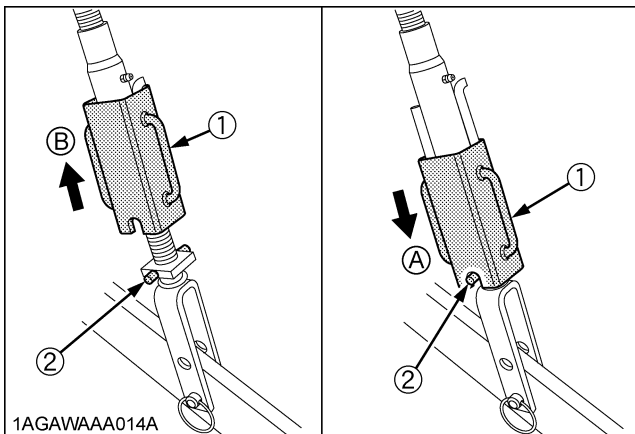

(1) Adjusting handle
(2) Lock pin

(A) "LOCK POSITION"
(B) "UNLOCK POSITION"

■ Top Link

1. Adjust the angle of the implement to the desired position by shortening or lengthening the top link. After adjustment, tighten the lock nut securely.
2. The proper length of the top link varies according to the type of implement being used.

■ Telescopic Stabilizers

Adjust the telescopic stabilizers to control horizontal sway of the implement. Select the proper set of holes by referring to the "Hydraulic Control Unit Use Reference Chart" in "REMOTE HYDRAULIC CONTROL SYSTEM" in "HYDRAULIC UNIT" section.

After aligning satisfactorily, insert the set-pin through any one of the 4 holes on the outer tube that align with one of the holes on the inner bar, both stabilizers will be locked. If the set-pin is inserted through the slot to engage one of the holes on the inner bar, a limited degree of sway will be permitted.

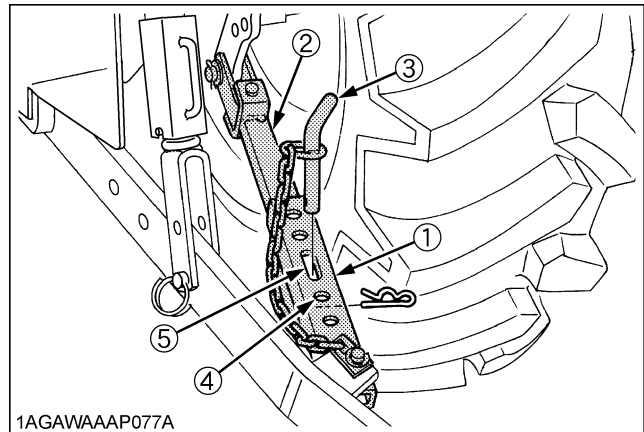

(1) Outer tube
(2) Inner bar
(3) Set-pin
(4) Hole
(5) Slot

■ Telescopic Lower Links

To attach an implement, follow the instructions below:

1. Push the levers, pull out the lower link ends, and attach to the implement.
2. Back up the tractor slightly to make sure the lower links are pushed in securely.

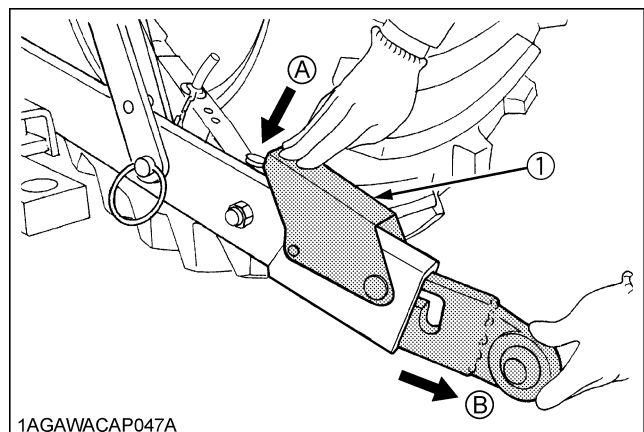

(1) Lever

(A) "PUSH"
(B) "PULL OUT"

DRAWBAR



WARNING

To avoid personal injury or death:

- Never pull from the top link, the rear axle or any point above the drawbar. Doing so could cause the tractor to tip over rearward causing personal injury or death.

■ Adjusting Drawbar Length

When towing an implement, recommend use of (A) or (B) hole in drawbar.

The drawbar load is referred to "IMPLEMENT LIMITATIONS" section.

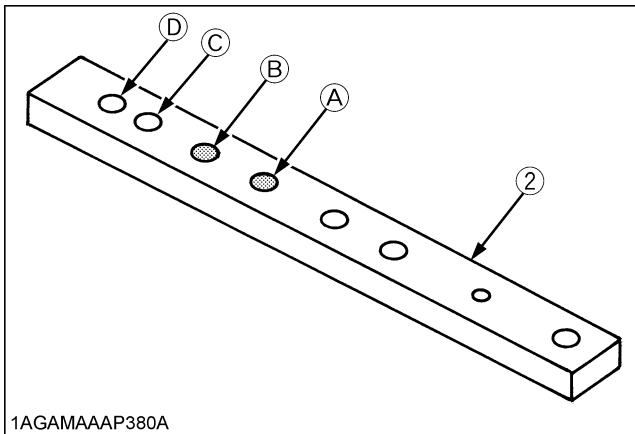
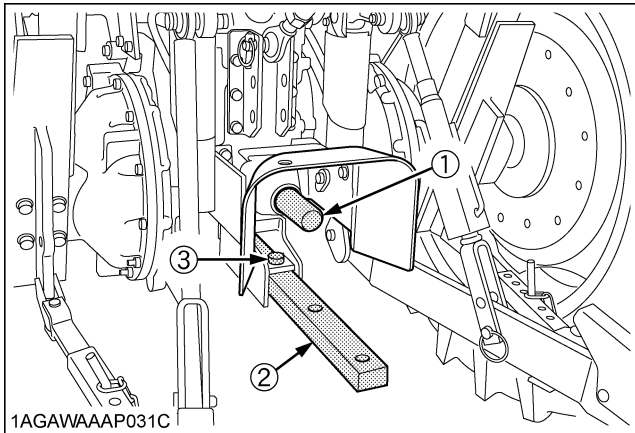

- (1) PTO shaft
 (2) Drawbar
 (3) Pivot pin

Holes : (A),(B)

Hole	Tractor model
(A)	L3560
(B)	L4060, L4760, L5060, L5460, L6060

■ Swing Drawbar

The drawbar can be used in three different ways as illustrated below. Assemble it correctly with joint pins set at the points as marked by ● in the figure.

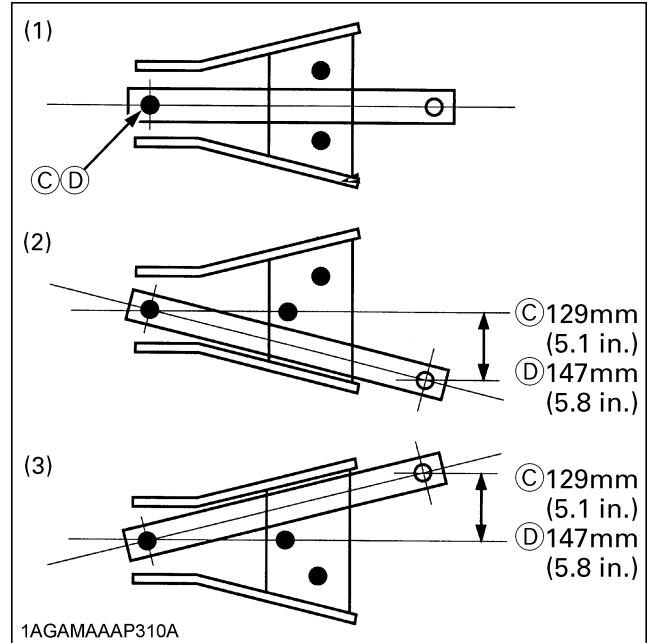

Holes : (C),(D)

Hole	Tractor model
(C)	L3560
(D)	L4060, L4760, L5060, L5460, L6060

HYDRAULIC UNIT

The standard tractor has following hydraulic control systems as shown below. Therefore, use the most appropriate system for the implement you are using.

◆ 3-Point Hitch Control System

1. Position Control
2. Draft Control (if equipped)
3. Mixed Control (if equipped)
4. Float Control

◆ Remote Hydraulic Control System

IMPORTANT :

- Do not operate until the engine is warmed up. If operation is attempted when the engine is still cold, the hydraulic system may be damaged.
- If noises are heard when implement is lifting after the hydraulic control lever has been activated, the hydraulic mechanism is not adjusted properly. Unless corrected, the unit will be damaged. Contact your KUBOTA Dealer for adjustment.

3-POINT HITCH CONTROL SYSTEM



WARNING

To avoid personal injury or death:

- Before using the 3-point hitch controls, ensure that no person or object is in the area of the implement or 3-point hitch. Do not stand on or near the implement or between the implement and tractor when operating the 3-point hitch controls.

■ Position Control

This will control the working depth of 3-point implements regardless of the amount of pull required.

Place the draft control lever in the lowest position and set the implement working depth with the position control lever.

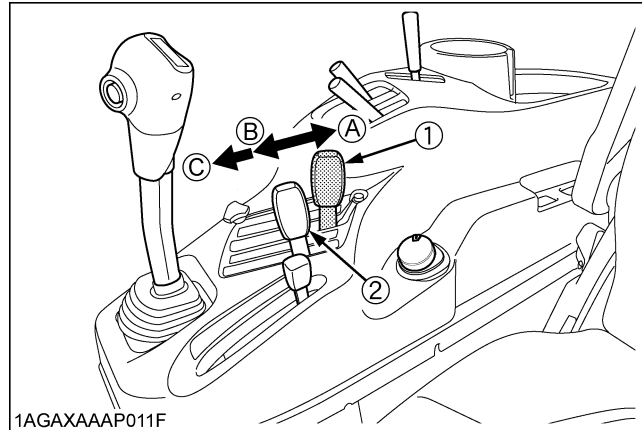

- (1) Position control lever
(2) Draft control lever [if equipped]

- (A) "UP"
(B) "DOWN"
(C) "FLOAT"

■ Draft Control (if equipped)

This will control the pull of the 3-point implement. As the load on the 3-point hitch changes due to various soil conditions, the draft control system automatically responds to these changes by either raising or lowering the implement slightly to maintain a constant pull.

Place the position control lever in the lowest position and set the implement pull with the draft control lever.

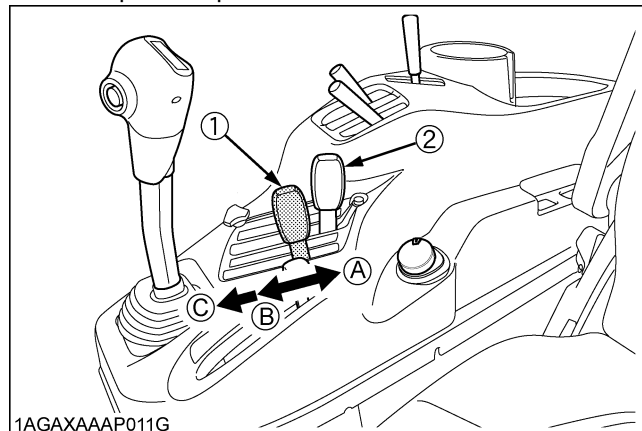

- (1) Draft control lever
(2) Position control lever

- (A) "SENSITIVE"
(B) "INSENSITIVE"
(C) "FLOAT"

Mixed Control

In draft control, when draft decreases, the implement automatically lowers to increase draft. However, the implement sometimes lowers too much. To limit the degree, the implement can be lowered, set the position control lever at the lowest working depth desired for the implement. Lower the draft control lever to the point where the implement is at the desired depth. This stops the implement from going too deep and causing loss of traction and ground speed.

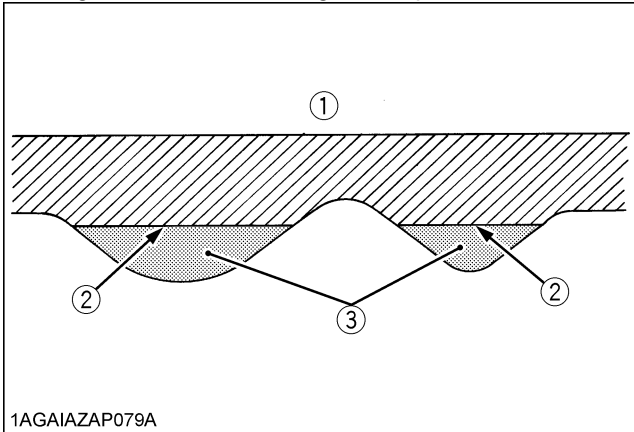

1AGAIAZAP079A

- (1) Ground surface
- (2) Implement penetrate limit
- (3) Light soil

Float Control

Place both the draft control lever and the position control lever in the float position to make the lower links move freely along with the ground conditions.

3-point Hitch Lowering Speed



WARNING

To avoid personal injury or death:

- Fast lowering speed may cause damage or injury. Lowering speed of implement should be adjusted to 2 or more seconds.

The lowering speed of the 3-point hitch can be controlled by adjusting the 3-point hitch lowering speed knob.

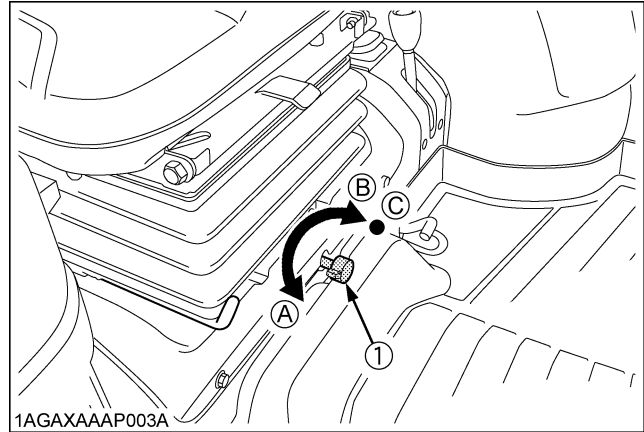

1AGAXAAP003A

- (1) 3-point hitch lowering speed knob
- (A) "FAST"
- (B) "SLOW"
- (C) "LOCK"

DUAL REMOTE HYDRAULIC CONTROL SYSTEM

The tractor is equipped with the double-acting 2-segment hydraulic control valve for front loader.

To apply the hydraulic power take-off for general attachments, keep the following point in mind.

Control Lever and Hydraulic Hose Connections

Connect the control lever in its specified direction and the hydraulic hoses to their specified ports.

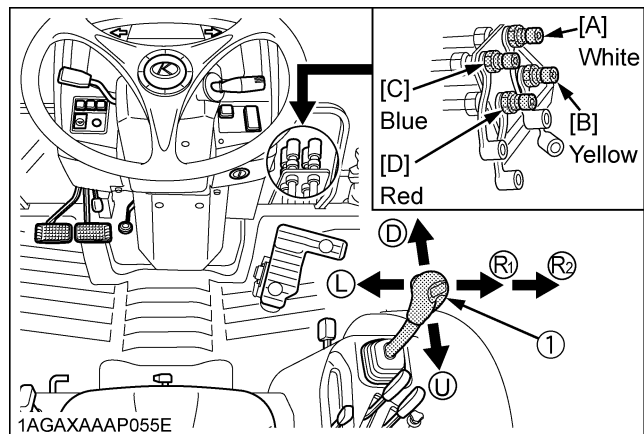

1AGAXAAP055E

- (1) Loader / Remote control valve lever
- (R) "RIGHT"
- (L) "LEFT"
- (U) "UP"
- (D) "DOWN"

Pressure →
 Hydraulic outlet ports of first segment Returning ←

Lever		UP		DOWN	
Port	[A]	In	←	Out	→
	[B]	Out	→	In	←

Hydraulic outlet ports of second segment

Lever		RIGHT		LEFT	
Port	[C]	In	←	Out	→
	[D]	Out	→	In	←

IMPORTANT :

To avoid damage of the attachments:

- Do not connect attachments through the hydraulic motor to the [C] and [D] ports. If the control lever is moved to the Regeneration position (R1), the seals on the hydraulic motor will be damaged.
- This control valve is provided with the Regeneration position. When the [C] and [D] ports are used to take off hydraulic power for the hydraulic cylinder, be sure to connect the [C] port to the "Head-End" side port of the hydraulic cylinder.
- Make the following connections when using this valve to take off hydraulic power for the hydraulic cylinder.

Colored Coupler	Hydraulic Cylinder port
[B: Yellow], [C: Blue]	Head-End side
[A: White], [D: Red]	Rod-End side

◆ **Rear Hydraulic Outlet (if equipped)**

With the optional kit in place, oil from the loader valve can be taken out of the back of the tractor.

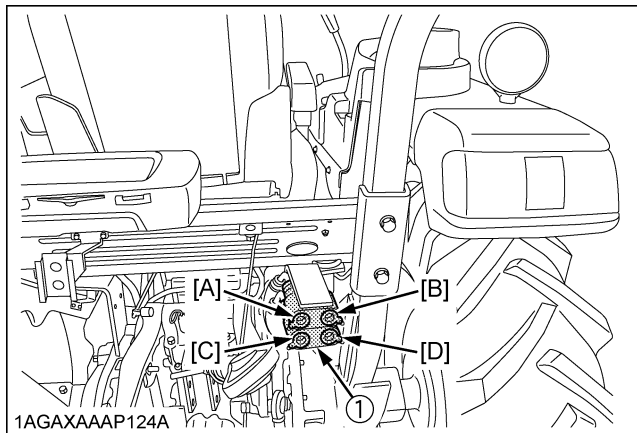

(1) Rear Hydraulic Outlet

NOTE :

- With this optional kit in place, oil cannot be taken for the front loader.
- If the optional remote hydraulic control valve is already in place, this kit cannot be additionally installed.

■ **Loader / Remote Control Valve Lever**

1. Before moving the lever, make sure that the hydraulic hoses for attachments are connected.
2. Move the lever diagonally (a, b, c shown in the figure), and the first and second segments can be controlled at once.

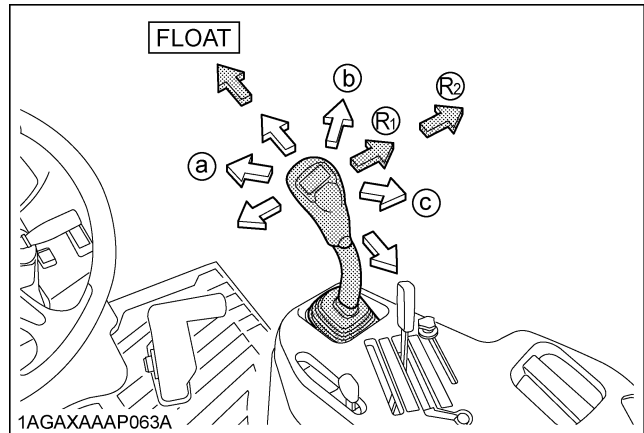

NOTE :

- Move the lever to the "FLOAT" position, and it will be held there by the detent mechanism. To use the valve as a floating valve with detents, connect the hydraulic hoses to ports [A] and [B].
- When taking off hydraulic power from port [D], the flow rate can be adjusted in two stages with the lever. The flow rate is high at position (R1) and low at position (R2). Move the lever to position (R1) or (R2) depending on the attachment in use.

Valve Lock



WARNING

To avoid injury or death from crushing:

- Do not utilize the valve lock for tractor maintenance or repair.
- The valve lock is to prevent accidental actuation when implement is not in use or during transport.

The control valve is equipped with a valve lock feature. The control valve is locked in the neutral position. The lock is not intended and will not prevent a leak down of the implement during the period of storage.

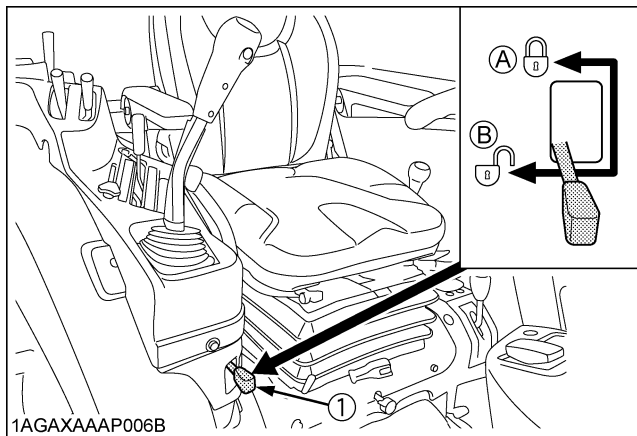

(1) Lock lever

(A) "Lock"
(B) "Unlock"

REMOTE HYDRAULIC CONTROL SYSTEM (if equipped)

The hydraulic auxiliary control valves can be installed up to triple segments.

Remote Control Valve

There are two types of remote valves available for these models.

- Double acting valve:
- Double acting valve with float position:
This valve may be placed in the float mode with the control lever all the way forward. The cylinder is free to extend or retract, letting an implement such as a loader bucket follow the ground.

Remote Control Valve Lever

The remote control valve lever directs pressurized oil flow to the implement hydraulic system.

[Example: Installing triple segment valve]

1st 3rd	Double acting valve
2nd	Double acting valve with float position

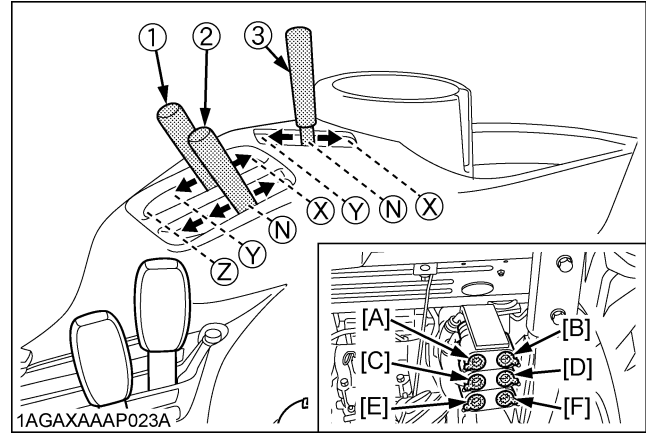

- (1) Remote control valve lever with Double acting valve (1)
- (2) Remote control valve lever with Double acting valve / Float position (2)
- (3) Remote control valve lever with Double acting valve (3)

Pressure →
Returning ←

Lever (1)	---	Y	X
Port	[A]	In ←	Out →
	[B]	Out →	In ←

Lever (2)	Z	Y	X
Port	[C] In	In ←	Out →
	[D] Out	Out →	In ←

Lever (3)	---	Y	X
Port	[E]	In ←	Out →
	[F]	Out →	In ←

	Coupler size
Port [A] [B] [C] [D] [E] [F]	PT 1/2

IMPORTANT :

- Do not hold the lever in the "REARWARD" or "FORWARD" position once the remote cylinder has reached the end of the stroke, as this will cause oil to flow through the relief valve. Forcing oil through the relief valve for extended periods will overheat the oil.
- When using the tractor hydraulic system to power front loader, do not operate boom and bucket cylinders simultaneously.

NOTE :

- To use the single-acting cylinder with the float valve, connect this cylinder to the [C] port.
To extend a single-acting cylinder, pull the remote control valve lever rearward. To retract a cylinder, push it fully forward to the "FLOAT" position. Do not hold it in the down position, the transmission fluid may be overheat.

**■ Remote Control Valve Coupler
Connecting and Disconnecting****WARNING**

To avoid personal injury or death:

- Stop the engine and relieve pressure before connecting or disconnecting lines.
- Do not use your hand to check for leaks.

◆ Connecting

1. Clean both couplers.
2. Remove dust plugs.
3. Insert the implement coupler to the tractor hydraulic coupler.
4. Pull the implement coupler slightly to make sure couplers are firmly connected.

◆ Disconnecting

1. Lower the implement first to the ground to release hydraulic pressure in the hoses.
2. Clean the couplers.
3. Relieve pressure by moving hydraulic control levers with engine shut off. Pull the hose straight from the hydraulic coupler to release it.
4. Clean oil and dust from the coupler, then replace the dust plugs.

NOTE :

- Your local KUBOTA Dealer can supply parts to adapt couplers to hydraulic hoses.

Hydraulic Control Unit Use Reference Chart

In order to handle the hydraulics properly, the operator must be familiar with the following. Though this information may not be applicable to all types of implements and soil conditions, it is useful for general conditions.

Implement	Soil condition	with Position control		with Draft control		Gauge wheel	Telescopic stabilizers	Remarks
		1AGAMAAAP314A 1AGAWACAP046B	1AGAXAAP064A	1AGAWACAP046C	1AGAXAAP011H			
Moldboard plow	Light soil Medium soil Heavy soil	1 or 2 2 or 3 3	Position control	1 or 2 2 or 3 3	Draft and Mixed control	YES/NO	Loose	Insert the set-pin through the slot on the outer tube that align with one of the holes on the inner bar. For implements with gauge wheels, lower the position control lever all way.
Disc plow	---	2 or 3		2 or 3				
Harrow (spike, springtooth, disc type)	---	2 or 3		2 or 3	Place the draft control lever to the suitable position and set the implement pull with the position control lever			
Sub-soiler ...								
Weeder, ridger...	---	3		4	Position control			
Earthmover, digger, scraper, manure fork, rear carrier.....			Hold the draft control lever at the most front position during operation.		YES/NO			
Mower (mid- and rear-mount type)			NO					

TIRES, WHEELS AND BALLAST

TIRES

WARNING

To avoid personal injury or death:

- Do not attempt to mount a tire on a rim. This should be done by a qualified person with the proper equipment.
- Always maintain the correct tire pressure. Do not inflate tires above the recommended pressure shown in the operator's manual.

IMPORTANT :

- Do not use tires other than those approved by KUBOTA.

■ Inflation Pressure

Though the tire pressure is factory-set to the prescribed level, it naturally drops slowly in the course of time. Thus, check it everyday and inflate as necessary.

NOTE :

- Maintain the maximum pressure in front tires, if using a front loader or when equipped with a full load of front weights.

	Tire sizes	Inflation Pressure
Rear	12.4-24, 4PR	140 kPa (1.4 kgf/cm ² , 20 psi)
	14.9-24, 4PR	140 kPa (1.4 kgf/cm ² , 20 psi)
	14.9-26, 4PR	140 kPa (1.4 kgf/cm ² , 20 psi)
	355/80-D20, 4PR	100 kPa (1.0 kgf/cm ² , 14 psi)
	44 x 18-20, 6PR	170 kPa (1.7 kgf/cm ² , 24 psi)
Front	7.2-16, 4PR	150 kPa (1.5 kgf/cm ² , 22 psi)
	8.3-16, 4PR	150 kPa (1.5 kgf/cm ² , 22 psi)
	9.5-16, 4PR	205 kPa (2.1 kgf/cm ² , 30 psi)
	27 x 8.50-15, 4PR	85 kPa (8.5 kgf/cm ² , 12 psi)
	29 x 12.50-15, 4PR	140 kPa (1.4 kgf/cm ² , 20 psi)

■ Dual Tires

Dual tires are not approved.

WHEEL ADJUSTMENT

WARNING

To avoid personal injury or death:

- When working on slopes or when working with trailer, set the wheel tread as wide as practical for maximum stability.
- Support tractor securely on stands before removing a wheel.
- Do not work under any hydraulically supported devices. They can settle, suddenly leak down, or be accidentally lowered. If necessary to work under tractor or any machine elements for servicing or adjustment, securely support them with stands or suitable blocking beforehand.
- Never operate tractor with a loose rim, wheel, or axle.

■ Front Wheels (with 4-wheel drive)

Front tread can not be adjusted.

IMPORTANT :

- Do not turn front discs to obtain wider tread.
- When re-fitting or adjusting a wheel, tighten the bolts to the following torques then recheck after driving the tractor 200 m (200 yards) and 10 times of shuttle movement by 5 m (5 yards), and thereafter according to service interval.
(See "MAINTENANCE" section.)

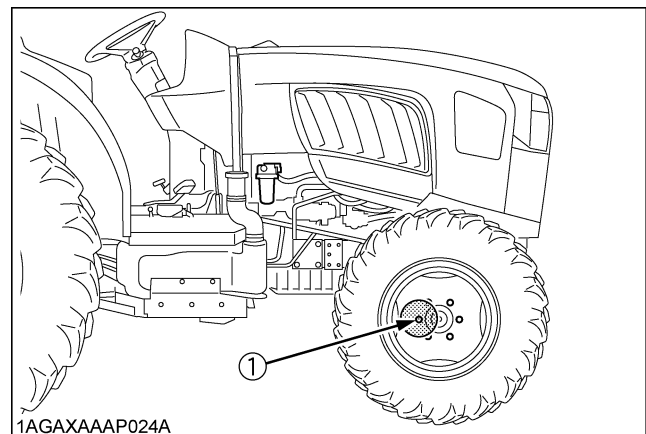

- (1) [L3560, L4060, L4760]
137 N-m (14 kgf-m, 100 ft-lbs)
[L5060, L5460, L6060]
185 N-m (19 kgf-m, 136 ft-lbs)

NOTE :

- Wheels with beveled or tapered holes: Use the tapered side of lug nut.

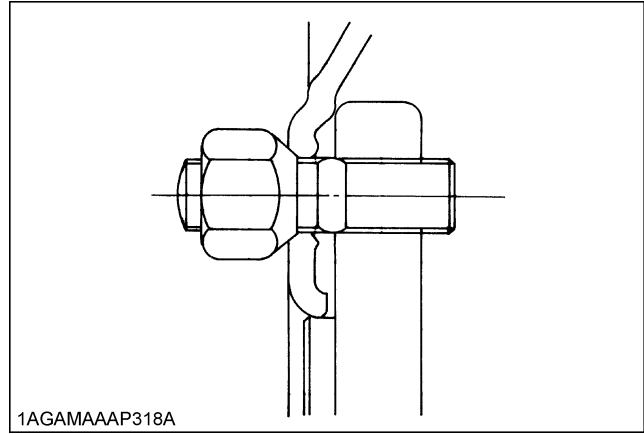

1AGAMAAAP318A

	Models	L3560				
	Tires	7-16, 7.2-16 Farm	27 x 8.50-15 Turf	27 x 10.50-15 Turf	29 x 12.50-15 Turf	10-16.5 IND
	Tread	1155 mm (45.5 in.)	1200 mm (47.2 in.)	1230 mm (48.4 in.)	1170 mm (46.1 in.)	1195 mm (47.0 in.)
	Models	L4060				
	Tires	8-16, 8.3-16 Farm	27 x 8.50-15 Turf	27 x 10.50-15 Turf	29 x 12.50-15 Turf	10-16.5 IND
	Tread	1155 mm (45.5 in.)	1200 mm (47.2 in.)	1230 mm (48.4 in.)	1170 mm (46.1 in.)	1195 mm (47.0 in.)
	Models	L4760				
	Tires	8-16, 8.3-16 Farm	27 x 10.50-15 Turf	29 x 12.50-15 Turf	305R343 Turf	10-16.5 IND
	Tread	1300 mm (51.2 in.)	1375 mm (54.1 in.)	1425 mm (56.1 in.)	1455 mm (57.3 in.)	1340 mm (52.8 in.)
	Models	L5060, L5460, L6060				
	Tires	9.5-16 Farm	27 x 10.5-15 Turf	29 x 12.50-15 Turf	305R343 Turf	10-16.5 IND
	Tread	1340 mm (52.8 in.)	1375 mm (54.1 in.)	1425 mm (56.1 in.)	1455 mm (57.3 in.)	1340 mm (52.8 in.)

NOTE :

- IND...for Industrial



WARNING

To avoid personal injury or death:

- Before jacking up the tractor, park it on a firm and level ground and chock the rear wheels.
- Fix the front axle to keep it from pivoting.
- Select jacks that withstand the machine weight and set them up as shown below.

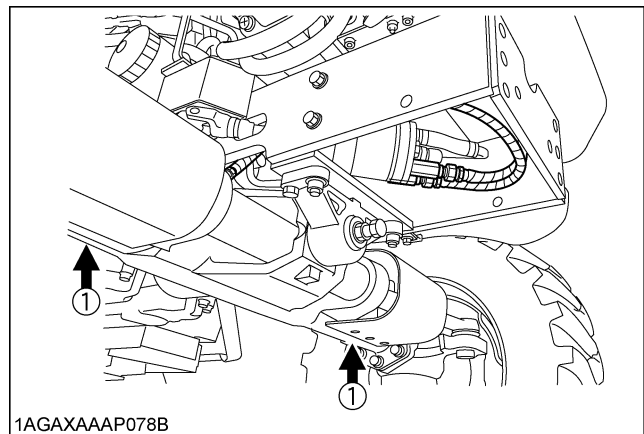

1AGAXAAP078B

(1) Jack points

■ Rear Wheels

Rear tread width can be adjusted as shown with the standard equipped tires.

To change the tread width

1. Remove the wheel rim and / or disk mounting bolts.
2. Change the position of the rim and / or disk (right and left) to the desired position, and tighten the bolts.

IMPORTANT :

- Always attach wheels as shown in the drawings.
- If not attached as illustrated, transmission parts may be damaged.
- When re-fitting or adjusting a wheel, tighten the bolts to the following torques then recheck after driving the tractor 200 m (200 yards) and 10 times of shuttle movement by 5 m (5 yards), and thereafter according to service interval.
(See "MAINTENANCE" section.)

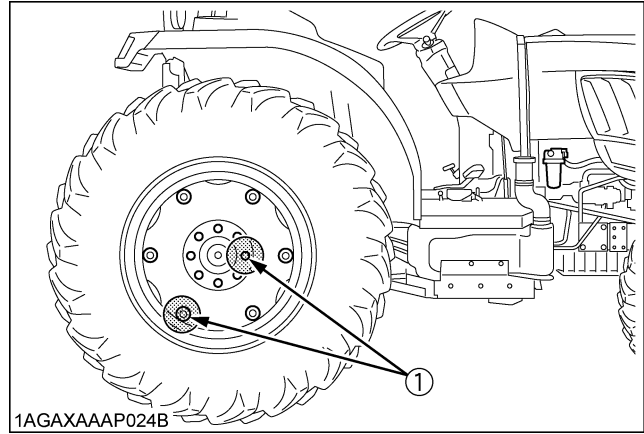

(1) 215 N-m (22 kgf-m, 160 ft-lbs)

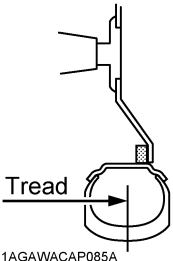
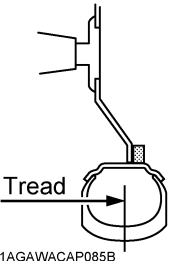
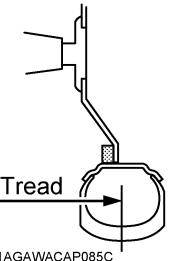
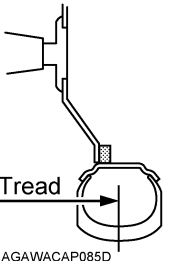
Models	 1AGAWACAP085A	 1AGAWACAP085B	 1AGAWACAP085C	 1AGAWACAP085D
L3560 12.4-24 Farm	1200 mm (47.2 in.)	1300 mm (51.2 in.)	1385 mm (54.5 in.)	1480 mm (58.3 in.)
L4060, L4760 14.9-24 Farm	---	1285 mm (50.6 in.)	1435 mm (56.5 in.)	1530 mm (60.2 in.)
L3560 420/70-24 IND	---	1325 mm (52.2 in.)	1360 mm (53.5 in.)	1465 mm (57.7 in.)
L4060, L4760 17.5L-24 IND	---	1340 mm (52.8 in.)	1380 mm (54.3 in.)	1490 mm (58.7 in.)
L5060, L5460, L6060 13.6-28 Farm	1220 mm (48.0 in.)	1330 mm (52.4 in.)	1425 mm (56.1 in.)	1530 mm (60.2 in.)
L5060, L5460, L6060 14.9-26 Farm	---	---	1325 mm (52.2 in.)	1430 mm (56.3 in.)
L5060, L5460, L6060 17.5L-24 IND	---	1360 mm (53.5 in.)	1395 mm (54.9 in.)	1500 mm (59.1 in.)

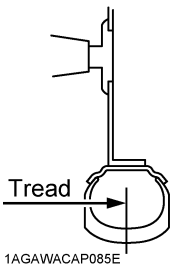
Models	
L4060, L4760, L5060, L5460, L6060 610R470 Turf	1515 mm (59.6 in.)
L3560 355/80-D20 Turf	1270 mm (50.0 in.)
L4060 355/80-D20 Turf	1290 mm (50.8 in.)
L3560 41/18LL x 16.1 Turf	1420 mm (55.9 in.)
L4060, L4760, L5060, L5460, L6060 41/18LL x 16.1 Turf	1440 mm (56.7 in.)
L3560 44 x 18-20 Turf	1400 mm (55.1 in.)
L3560, L4060, L4760, L5060, L5460, L6060 44 x 18-20 Turf	1415 mm (55.7 in.)

! WARNING
To avoid personal injury or death:

- Before jacking up the tractor, park it on a firm and level ground and chock the front wheels.
- Fix the front axle to keep it from swinging.
- Select a jack that withstands the machine weight and set it up as shown below.

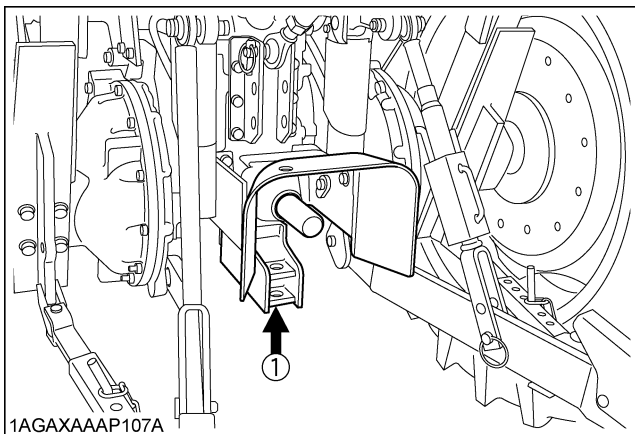

(1) Jack point

BALLAST

! WARNING

To avoid personal injury or death:

- Additional ballast will be needed for transporting heavy implements. When the implement is raised, drive slowly over rough ground, regardless of how much ballast is used.
- Do not fill the front wheels with liquid to maintain steering control.

■ Front Ballast

Add weights if needed for stability and improve traction. Heavy pulling and heavy rear mounted implements tend to lift front wheels.

Add enough ballast to maintain steering control and prevent tip over. Remove weight when no longer needed.

◆ Front End Weights (option)

The front end weights can be attached to the bumper. See your implement operator's manual for required number of weights or consult your local KUBOTA Dealer to use.

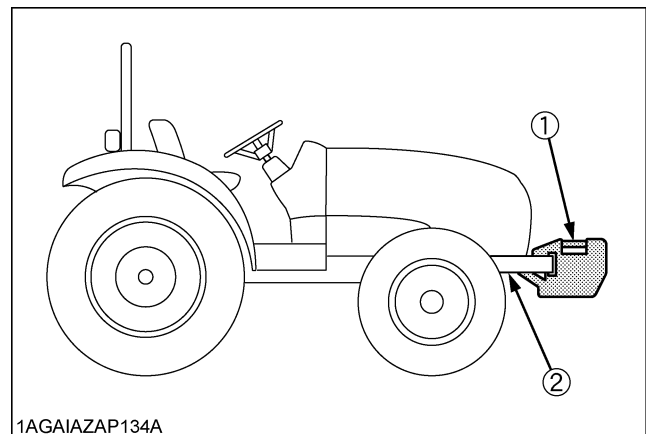

(1) Front end weights
(2) Bumper

IMPORTANT :

- Do not overload tires.
- Add no more weight than indicated in chart.

NOTE :

- The front end weights can be attached to the bumper (option on 4WD models - North America only).

Maximum weight	25 kg x 7 pieces (386 lbs.)
----------------	--------------------------------

■ Rear Ballast

Add weight to rear wheels if needed to improve traction or for stability. The amount of rear ballast should be matched to job and the ballast should be removed when it is not needed.

The weight should be added to the tractor in the form of liquid ballast, rear wheel weights or a combination of both.

◆ Rear Wheel Weights (option)

The rear wheel weights can be attached to the rear wheel. See your implement operator's manual for required number of weights or consult your local KUBOTA Dealer to use.

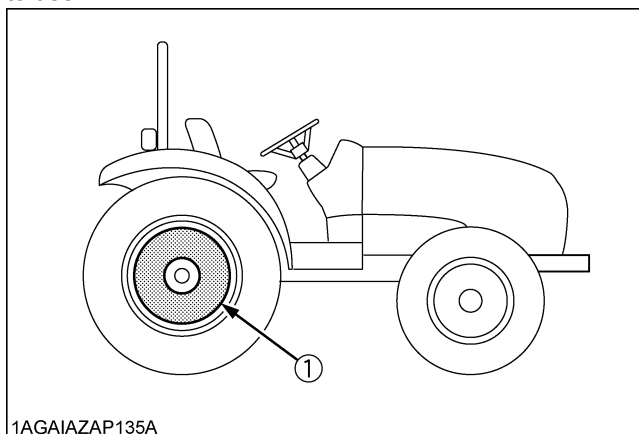

1AGAI AZAP135A

(1) Rear wheel weights

IMPORTANT :

- Do not overload tires.
- Add no more weight than indicated in chart.

Model	Maximum weight per wheel
L3560, L4060, L4760	28 kg x 3 Pieces (185 lbs.)
L5060, L5460, L6060	47 kg x 3 Pieces (310 lbs.)

■ Liquid Ballast in Rear Tires

Water and calcium chloride solution provides safe economical ballast. Used properly, it will not damage tires, tubes or rims. The addition of calcium chloride is recommended to prevent the water from freezing. Use of this method of weighting the wheels has the full approval of the tire companies. See your tire dealer for this service.

Liquid weight per tire (75 Percent filled)

Tire sizes	12.4-24	420/70-24	14.9-24
Slush free at -10 °C (14 °F) Solid at -30 °C (-22 °F) [Approx. 1 kg (2 lbs.) CaCl ₂ per 4 L (1 gal.) of water]	130 kg (285 lbs.)	195 kg (430 lbs.)	205 kg (450 lbs.)
Slush free at -24 °C (-11 °F) Solid at -47 °C (-52 °F) [Approx. 1.5 kg (3.5 lbs.) CaCl ₂ per 4 L (1 gal.) of water]	135 kg (295 lbs.)	205 kg (450 lbs.)	215 kg (475 lbs.)
Slush free at -47 °C (-52 °F) Solid at -52 °C (-62 °F) [Approx. 2.25 kg (5 lbs.) CaCl ₂ per 4 L (1 gal.) of water]	145 kg (320 lbs.)	220 kg (485 lbs.)	225 kg (495 lbs.)

Tire sizes	17.5L-24	14.9-26	13.6-28
Slush free at -10 °C (14 °F) Solid at -30 °C (-22 °F) [Approx. 1 kg (2 lbs.) CaCl ₂ per 4 L (1 gal.) of water]	235 kg (515 lbs.)	215 kg (475 lbs.)	185 kg (405 lbs.)
Slush free at -24 °C (-11 °F) Solid at -47 °C (-52 °F) [Approx. 1.5 kg (3.5 lbs.) CaCl ₂ per 4 L (1 gal.) of water]	250 kg (550 lbs.)	225 kg (495 lbs.)	200 kg (441 lbs.)
Slush free at -47 °C (-52 °F) Solid at -52 °C (-62 °F) [Approx. 2.25 kg (5 lbs.) CaCl ₂ per 4 L (1 gal.) of water]	265 kg (585 lbs.)	235 kg (515 lbs.)	215 kg (475 lbs.)

IMPORTANT :

- Do not fill tires with water or solution more than 75% of full capacity (to the valve stem level at 12 o'clock position).

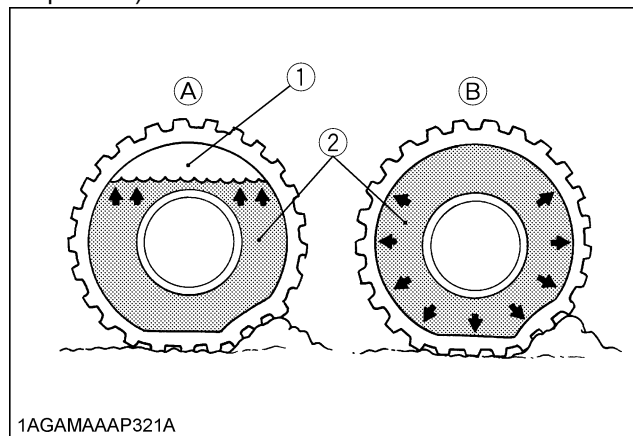

1AGAMAAAP321A

- (1) Air (A) Correct-75% Air compresses like a cushion
 (2) Water (B) Incorrect-100% Full Water can not be compressed

MAINTENANCE

SERVICE INTERVALS

No.	Items		Indication on hour meter													Interval	Ref. page				
			50	100	150	200	250	300	350	400	450	500	550	600	650					700	
1	Engine start system	Check	○	○	○	○	○	○	○	○	○	○	○	○	○	○	○	every 50 Hr	97		
2	Wheel bolt torque	Check	○	○	○	○	○	○	○	○	○	○	○	○	○	○	○	every 50 Hr	99		
3	Greasing	-	○	○	○	○	○	○	○	○	○	○	○	○	○	○	○	every 50 Hr	96		
4	Battery condition	Check		○		○		○		○		○		○		○	○	every 100 Hr	101	*3	
5	Fan belt	Adjust		○		○		○		○		○		○		○	○	every 100 Hr	99		
6	Brake	Adjust		○		○		○		○		○		○		○	○	every 100 Hr	100		
7	Clutch [GST/MT]	Adjust	◎	○		○		○		○		○		○		○	○	every 100 Hr	100		
8	Air cleaner element Primary element	Clean		○		○		○		○		○		○		○	○	every 100 Hr	99	*1	@
		Replace																every 1000 hour or 1 year	107	*4	
	Secondary element	Replace																every 1000 hour or 1 year	107	*4	
9	Transmission oil filter [HST]	Replace	◎			○				○					○		○	every 200 Hr	102		
10	Toe-in	Adjust				○				○					○		○	every 200 Hr	103		
11	Engine oil	Change	◎							○								every 400 Hr	103		
12	Engine oil filter	Replace	◎							○								every 400 Hr	104		
13	Hydraulic oil filter	Replace								○								every 400 Hr	104		
14	Transmission fluid	Change								○								every 400 Hr	104		
15	Fuel filter	Replace								○								every 400 Hr	106		@
16	Water separator	Clean								○								every 400 Hr	107		
17	Front axle case oil	Change								○								every 400 Hr	106		
18	Front axle pivot	Adjust													○			every 600 Hr	107		
19	Engine valve clearance	Adjust																every 800 Hr	107	*2	
20	Exhaust manifold	Check																every 1000 hour or 1 year	107	*2 *4	

No.	Items		Indication on hour meter													Interval	Ref. page				
			50	100	150	200	250	300	350	400	450	500	550	600	650					700	
21	Fuel injector nozzle tip	Clean																every 1500 Hr	107	*2	@
22	Oil separator element	Replace																every 1500 Hr	108		@
23	PCV (Positive Crankcase Ventilation) valve (Oil separator)	Check																every 1500 Hr	108	*2	@
24	EGR cooler	Check Clean																every 1500 Hr	108	*2	@
25	Cooling system	Flush																every 2000 hour or 2 year	108		
26	Coolant	Change																every 2000 hour or 2 year	108		
27	EGR system	Check Clean																every 3000 Hr	109	*2	@
28	Supply pump	Check																every 3000 Hr	109	*2	
29	DPF muffler	Clean																every 3000 Hr	110	*2	@
30	Turbo charger	Check																every 3000 Hr	109	*2	@
31	Fuel line	Check																every 1 year	110	*6	@
		Replace																every 4 year	112	*2 *6	
32	Intake air line	Check																every 1 year	110	*6	@
		Replace																every 4 year	112	*2 *6	
33	Power steering oil line	Check																every 1 year	111	*6	
		Replace																	every 4 year	113	*2 *6
34	Radiator hose and clamp	Check																every 1 year	111	*6	
		Replace																	every 4 year	112	*6
35	Oil cooler line [HST]	Check																every 1 year	112	*6	
		Replace																	every 4 year	113	*2 *6
36	Oil separator hose	Check																every 1 year	112	*6	
		Replace																	every 4 year	113	*2 *6

No.	Items		Indication on hour meter													Interval	Ref. page				
			50	100	150	200	250	300	350	400	450	500	550	600	650					700	
37	Lift cylinder hose	Check																every 1 year	112	*6	
		Replace																every 4 year	113	*2 *6	
38	DPF differential pressure sensor pipe	Check															every 1 year	112	*2		
39	EGR pipe	Check															every 1 year	112	*2		
40	Antifrost Heater for Oil Separator (if equipped)	Check															every 1 year	112			
41	DPF differential pressure sensor hose	Replace															every 2 year	112	*2		
42	Boost sensor hose	Replace															every 2 year	112	*2		
43	Fuel system	Bleed															Service as required	113			
44	Clutch housing	Drain														113					
45	Fuse	Replace														114					
46	Light bulb	Replace														115					
47	Radiator hose and clamp	Replace														116		*6			
48	Fuel line	Replace														116		*6			
49	Intake air line	Replace														116		*6			
50	Power Steering line	Replace														116		*6			
51	Oil cooler line	Replace														116		*6			
52	Oil separator hose	Replace														116		*6			

IMPORTANT :

- The jobs indicated by © must be done after the first 50 hours of operation.
- *1 Air cleaner should be cleaned more often in dusty conditions than in normal conditions.
- *2 Consult your local KUBOTA Dealer for this service.
- *3 When the battery is used for less than 100 hours per year, check the battery condition by reading the indicator annually.
- *4 Every 1,000 hours or every 1 year, whichever comes faster.
- *5 Every 2,000 hours or every 2 years, whichever comes faster.
- *6 Replace if any deterioration (crack, hardening, scar or deformation) or damage occurred.
However, must be replaced every 4 years regardless of the condition.
- The items listed above (@ marked) are registered as emission related critical parts by KUBOTA in the U.S.EPA nonroad emission regulation. As the engine owner, you are responsible for the performance of the required maintenance on the engine according to the above instruction.
Please see Warranty Statement in detail.

LUBRICANTS, FUEL AND COOLANT

No.	Locations	Capacities						Lubricants			
		L3560	L4060	L4760	L5060	L5460	L6060				
1	Fuel	51 L (13.5 U.S.gals.)						No. 2-D S15 diesel fuel No. 1-D S15 diesel fuel if temperature is below -10 °C (14 °F)			
2	Coolant	7.5 L (7.9 U.S.qts.)		8.2 L (8.7 U.S.qts.)				Fresh clean soft water with anti-freeze			
		Recovery tank: 0.6 L (0.6 U.S.qts.)									
3	Engine crankcase (with filter)	6.7 L (7.1 U.S.qts.)	8.2 L (8.7 U.S.qts.)	9.4 L (9.9 U.S.qts.)				● Engine oil : Refer to next page			
								Above 25 °C (77 °F)		SAE30, SAE10W-30 or 15W-40	
								-10 to 25 °C (14 to 77 °F)		SAE20, SAE10W-30 or 15W-40	
								Below -10 °C (14 °F)		SAE10W-30	
4	Transmission case	42 L (11.1 U.S.gals.)	43 L (11.4 U.S.gals.)	45 L (11.9 U.S.gals.)				● KUBOTA SUPER UDT-2 fluid			
5	Front axle case	6.5 L (6.9 U.S.qts.)		8.5 L (8.9 U.S.qts.)				● KUBOTA SUPER UDT-2 fluid or SAE80-SAE90 gear oil			
6	Greasing	No. of greasing points						Capacity	Type of grease		
	Front wheel case support	----		2				Until grease overflows.	Multipurpose Grease NLGI-2 OR NLGI-1 (GC-LB)		
	Front axle support	2									
	Top link	2									
	Top link bracket	2 [with Draft Control (if equipped)]									
	Lift rod	1									
	Lift cylinder	4									
	Battery terminal	2									
	Swivel seat	4						moderate amount			

NOTE :

The product name of KUBOTA genuine UDT fluid may be different from that in the Operator's Manual depending on countries or territories. Consult your local KUBOTA Dealer for further details.

NOTE :

◆ **Engine Oil:**

- Oil used in the engine should have an American Petroleum Institute (API) service classification and Proper SAE Engine Oil according to the ambient temperatures as shown above:

- Refer to the following table for the suitable API classification engine oil according to the engine type (with DPF (Diesel Particulate Filter) type engines) and the fuel.

Fuel used	Engine oil classification (API classification)
	Oil class for engines with DPF
Ultra Low Sulfur Fuel [<0.0015% (15 ppm)]	CJ-4

◆ **Fuel:**

- Use the ultra low sulfur diesel fuel only [below 0.0015% (15 ppm)] for these engines.
- Cetane number of 45 minimum. Cetane number greater than 50 is preferred, especially for temperatures below -20 °C (-4 °F) or elevations above 1500 m (5000 ft).
- Diesel fuels specified to EN 590 or ASTM D975 are recommended.
- No.2-D is a distillate fuel of lower volatility for engines in industrial and heavy mobile service. (SAE J313 JUN87)

◆ **Transmission Oil:**

*KUBOTA Super UDT-2: For an enhanced ownership experience, we highly recommend Super UDT-2 to be used instead of standard hydraulic/transmission fluid.

Super UDT-2 is a proprietary KUBOTA formulation that delivers superior performance and protection in all operating conditions.

Regular UDT is also permitted for use in this machine.

- Indicated capacities of water and oil are manufacturer's estimate.

PERIODIC SERVICE



WARNING

To avoid personal injury or death:

- Do not work under any hydraulically supported devices. They can settle, suddenly leak down, or be accidentally lowered. If necessary to work under tractor or any machine elements for servicing or adjustment, securely support them with stands or suitable blocking beforehand.

HOW TO OPEN THE HOOD



WARNING

To avoid personal injury or death from contact with moving parts;

- Never open the hood or engine side cover while the engine is running.
- Do not touch muffler or exhaust pipes while they are hot; Severe burns could result.
- Support hood with other hand while unlocking support link.

■ Hood

To open the hood, hold the hood and pull the release lever and open the hood.

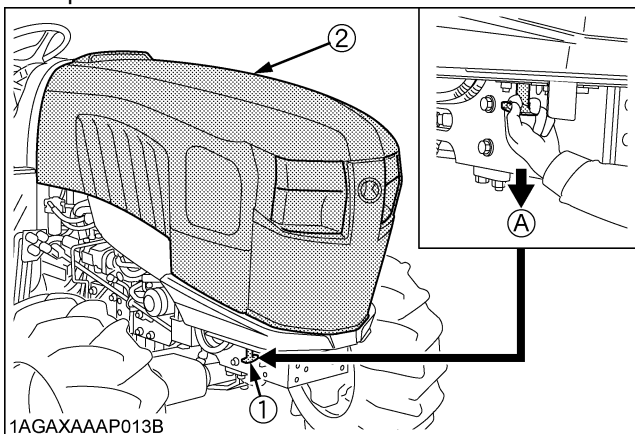

- (1) Release lever
(2) Hood

(A) "PULL"

NOTE :

- To close the hood, push the hood into position using both hands.

■ Side Cover

Remove the bolts as shown below.

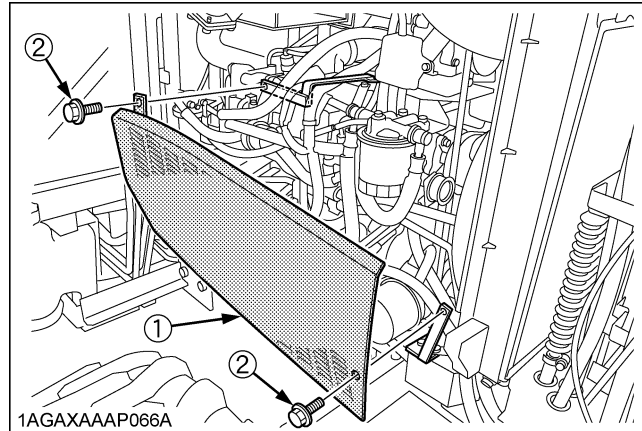

- (1) Side cover
(2) Bolt

■ Floor Sheet

1. Remove the bolts on the floor sheet cover.
2. Hoist the seat with nylon slings.

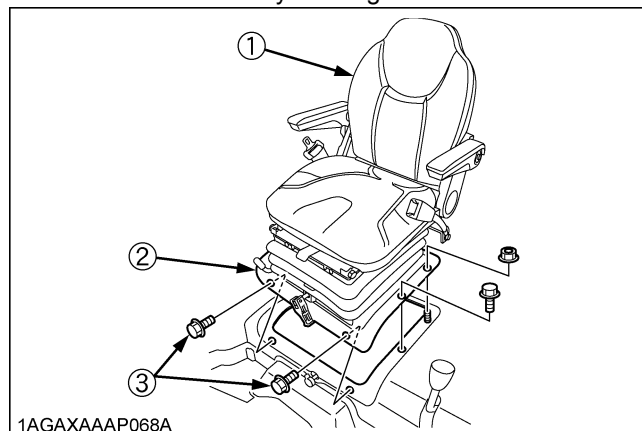

- (1) Seat
(2) Floor sheet cover
(3) Bolt

DAILY CHECK

For your own safety and maximum service life of the machine, make a thorough daily inspection before operating the machine to start the engine.



WARNING

To avoid personal injury or death:
Take the following precautions when checking the tractor.

- Park the machine on firm and level ground.
- Set the parking brake.
- Lower the implement to the ground.
- All residual pressure of the hydraulic system released.
- Stop the engine and remove the key.

■ Walk Around Inspection

Look around and under the tractor for such items as loose bolts, trash build-up, oil or coolant leaks, broken or worn parts.

■ Checking and Refueling



WARNING

To avoid personal injury or death:

- Do not smoke while refueling.
- Be sure to stop the engine before refueling.

1. Turn the key switch to "ON", check the amount of fuel by fuel gauge.
2. Fill fuel tank when fuel gauge shows 1/4 or less fuel in tank.

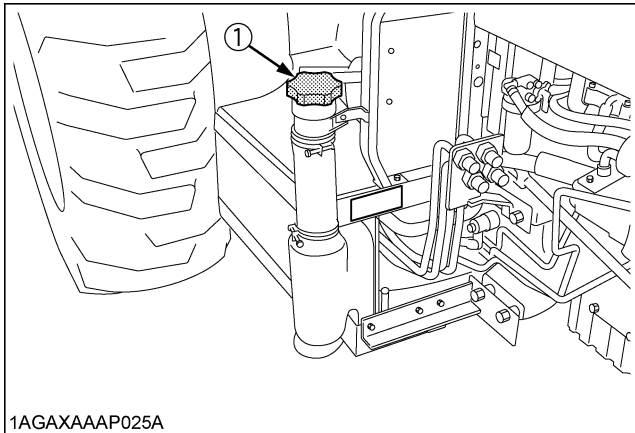

1AGAXAAP025A

(1) Fuel tank cap

◆ Refueling alarm

Suppose that you try to refuel with the key switch at ON. When you start refueling, the buzzer sounds intermittently.

When the tank gets close to full, the buzzer starts sounding continuously. Stop refueling just when the buzzer sound turns from intermittent to continuous.

Fuel tank capacity	51L (13.5 U.S.gals.)
--------------------	----------------------

IMPORTANT :

- Be sure to use Ultra Low Sulfur Fuel (S15).
- Do not permit dirt or trash to get into the fuel system.
- Be careful not to let the fuel tank become empty, otherwise air will enter the fuel system, necessitating bleeding before next engine start.
- If the engine runs out of fuel and stalls, the engine components may be damaged.
- Be careful not to spill during refueling. If a spill should occur, wipe it off at once, or it may cause a fire.
- To prevent condensation (water) accumulation in the fuel tank, fill the tank before parking overnight.

■ Checking Water Separator

1. As water is collected in the water separator, the red float is raised.
2. When the red float has reached the white line, close the fuel cock, loosen the retainer ring, take out the cup, and clean the cup. Be careful not to break the element.
3. Place the cup back into position. Bleed the fuel system.
(See "SERVICE AS REQUIRED" in "PERIODIC SERVICE" section.)

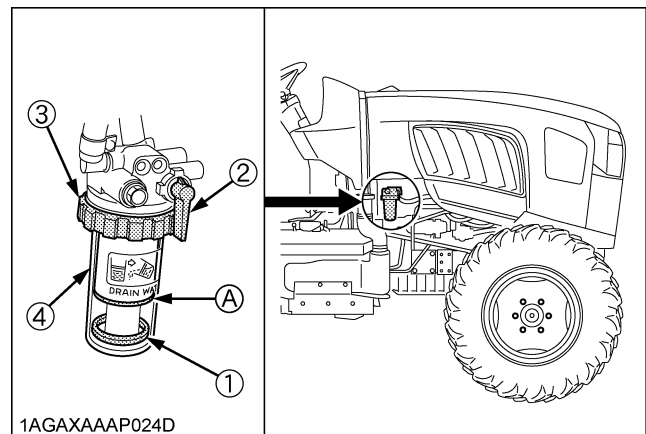

1AGAXAAP024D

- (1) Red float
- (2) Fuel cock
- (3) Retainer ring
- (4) Cup

(A) "WHITE LINE"

IMPORTANT :

- If water is drawn through to the fuel pump, extensive damage will occur.

■ Checking Engine Oil Level



WARNING

To avoid personal injury or death:

- Be sure to stop the engine before checking the oil level.

1. Park the machine on a flat surface.
2. Check engine oil before starting the engine or 5 minutes or more after the engine has stopped.
3. To check the oil level, draw out the dipstick, wipe it clean, replace it, and draw it out again. Check to see that the oil level lines between the 2 notches. If the level is too low, add new oil to the prescribed level at the oil inlet.
(See "LUBRICANTS" in "MAINTENANCE" section.)

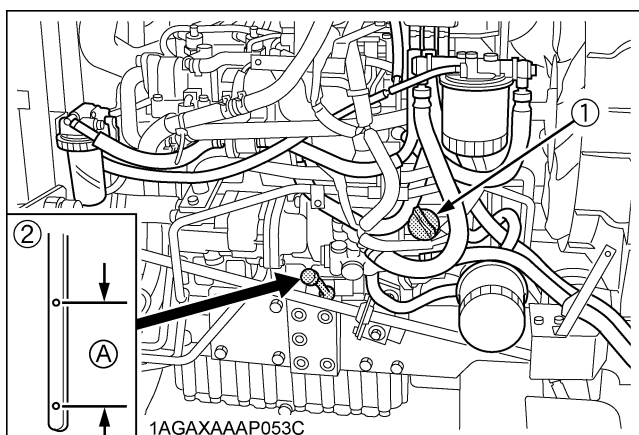

(1) Oil inlet (A) Oil level is acceptable within this range.
(2) Dipstick

IMPORTANT :

- When using an oil of different maker or viscosity from the previous one, remove all of the old oil. Never mix two different types of oil.
- If oil level is low, do not run engine.

NOTE :

- At times a small amount of fuel, which is used to regenerate the DPF, may get mixed with the engine oil and the engine oil may increase in volume.

■ Checking Transmission Fluid Level

1. Park the machine on a flat surface, lower the implement and shut off engine.
2. To check the oil level, draw out the dipstick, wipe it clean, replace it, and draw it out again. Check to see that the oil level lines between the 2 notches. If the level is too low, add new oil to the prescribed level at the oil inlet.
(See "LUBRICANTS" in "MAINTENANCE" section.)

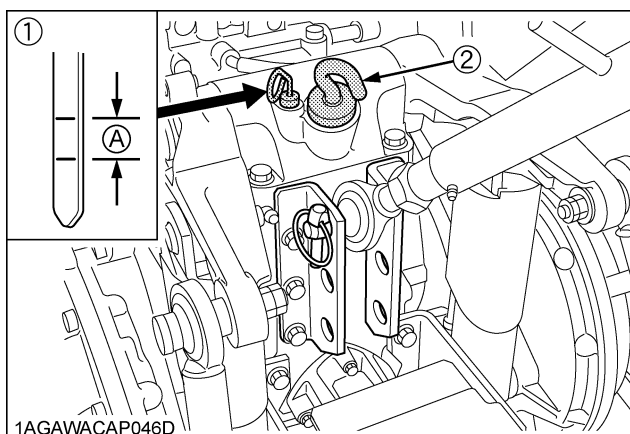

(1) Dipstick (A) Oil level is acceptable within this range.
(2) Oil inlet

IMPORTANT :

- If oil level is low, do not run engine.

■ Checking Coolant Level



WARNING

To avoid personal injury or death:

- Do not remove radiator cap while coolant is hot. When cool, slowly rotate cap to the first stop and allow sufficient time for excess pressure to escape before removing the cap completely.

1. Check to see that the coolant level is between the "FULL" and "LOW" marks of recovery tank.
2. When the coolant level drops due to evaporation, add soft water only up to the full level.
In case of leakage, add anti-freeze and soft water in the specified mixing ratio up to the full level.
(See "Flushing Cooling System and Changing Coolant" in "EVERY 2000 HOURS or 2 YEARS" in "PERIODIC SERVICE" section.)
3. When the coolant level is lower than "LOW" mark of recovery tank, remove the radiator cap and check to see that the coolant level is just below the port. If level is low, add coolant.

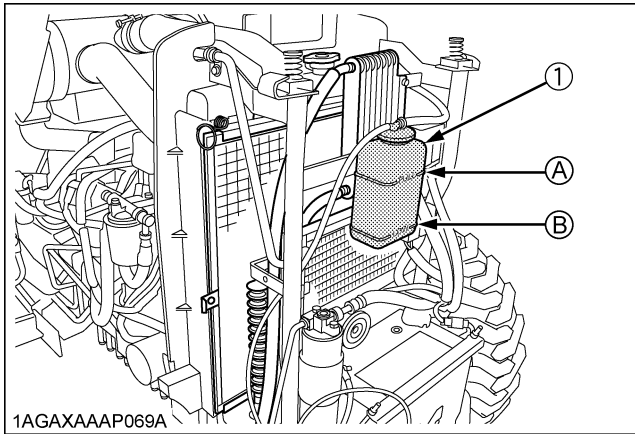

(1) Recovery tank

(A) "FULL"

(B) "LOW"

IMPORTANT :

- If the radiator cap has to be removed, follow the caution above and securely retighten the cap.
- Use clean, fresh soft water and anti-freeze to fill the radiator.
- If coolant should leak, consult your local KUBOTA Dealer.

■ Checking Dust Indicator

[L3560]

There is a dust indicator on the air cleaner body. If the red signal on the dust indicator is visible, clean the element immediately. (See "Cleaning Air Cleaner Primary Element" in "EVERY 100 HOURS" in "PERIODIC SERVICE" section.) Reset the red signal by pushing a "RESET" button after cleaning.

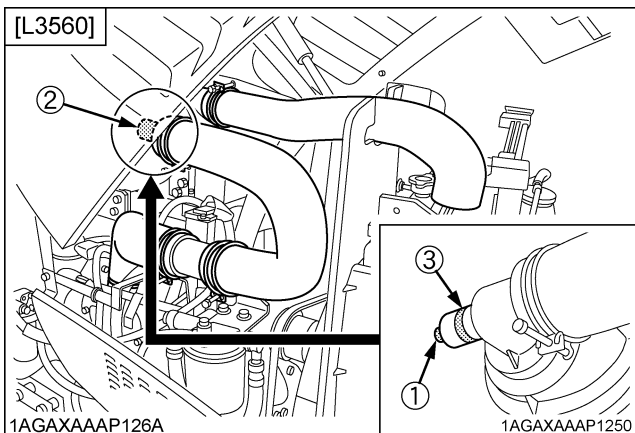

(1) "RESET" button

(2) Dust indicator

(3) Red signal

[L4060, L4760, L5060, L5460, L6060]

There is a dust indicator on the air cleaner body. If the yellow signal on the dust indicator has reached the red zone, clean the element immediately. (See "Cleaning Air Cleaner Primary Element" in "EVERY 100 HOURS" in "PERIODIC SERVICE" section.) Reset the yellow signal by pushing a "RESET" button after cleaning.

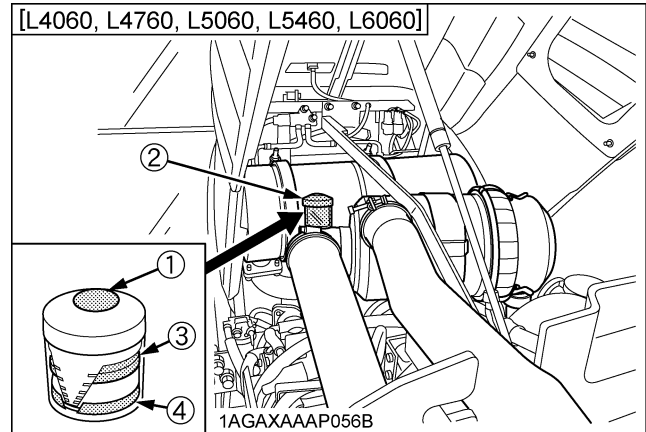

(1) "RESET" button

(2) Dust indicator

(3) Yellow signal

(4) Red zone

■ Cleaning Grill, Radiator Screen and Oil Cooler



WARNING

To avoid personal injury or death:

- Be sure to stop the engine before removing the screen.
- Before checking or cleaning the radiator screen, stop the engine and wait long enough until it is cooled down.

1. Check front grill and side screens to be sure they are clean of debris.
2. Detach the front skirt.
3. Detach the screen and remove all foreign materials.

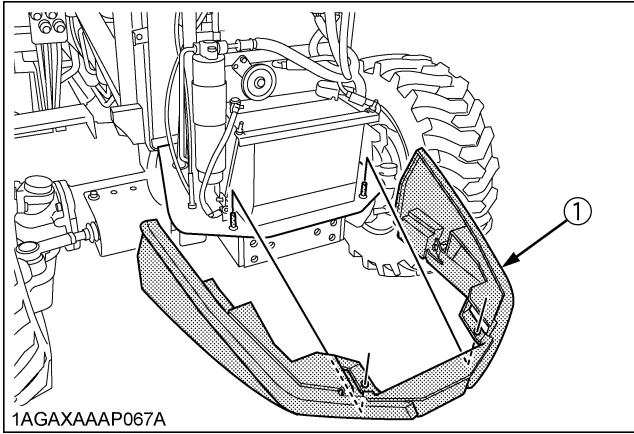

(1) Front skirt

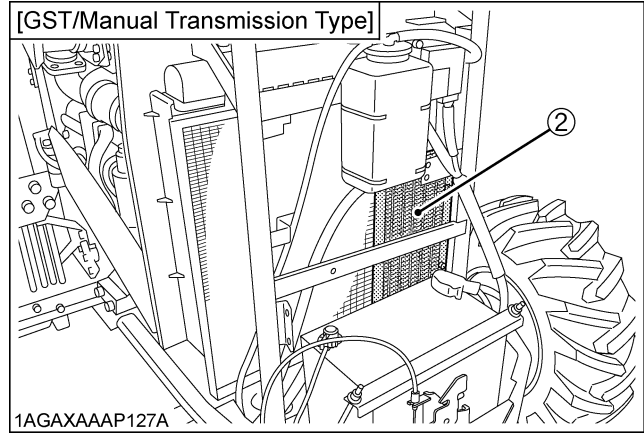

(1) Oil cooler
(2) Fuel cooler

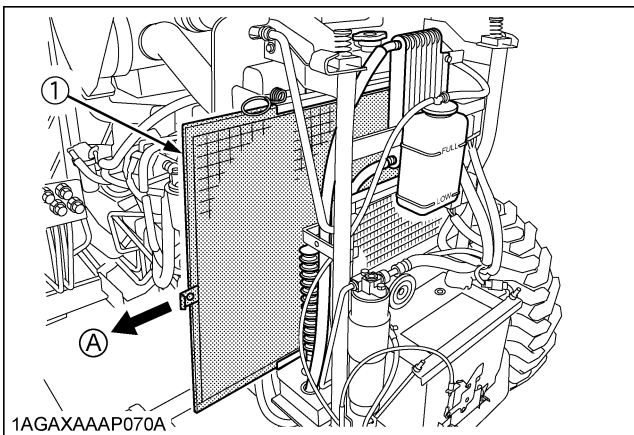

(1) Radiator screen (A) "DETACH"

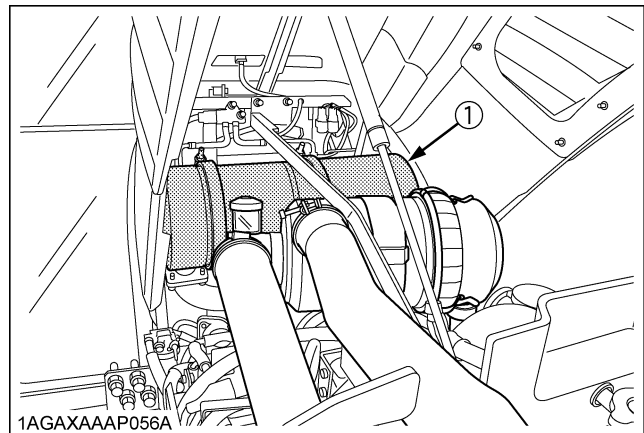
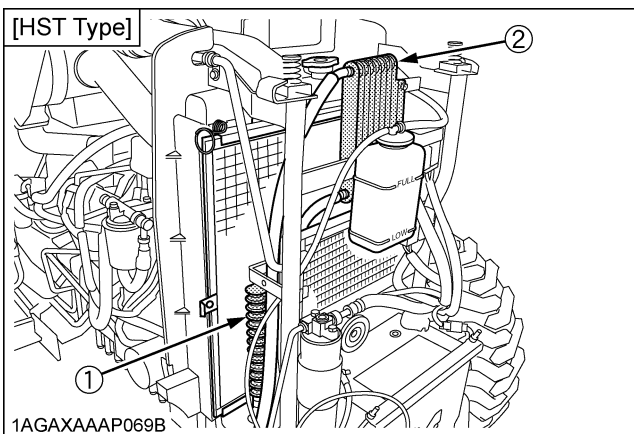

(1) DPF muffler

IMPORTANT :

- Grill and screen must be clean from debris to prevent engine from overheating and to allow good air intake for the air cleaner.

■ Checking DPF Muffler

⚠ WARNING

To avoid personal injury or death:

- Before checking or cleaning the DPF muffler, stop the engine and wait long enough until it is cooled down.

Check the DPF muffler and its surroundings for build-up of anything flammable. Otherwise a fire may result.

■ Checking Brake Pedal

[HST Type]



WARNING

To avoid personal injury or death:

- Be sure brake pedals have equal adjustment when using locked together. Incorrect or unequal brake pedal adjustment can cause the tractor to swerve or roll-over.

1. Inspect the brake pedals for free travel, and smooth operation.
2. Adjust if incorrect measurement is found: (See "Adjusting Brake Pedal" in "EVERY 100 HOURS" in "PERIODIC SERVICE" section.)

■ Checking Brake Pedals and Clutch Pedal

[GST / Manual Transmission Type]



WARNING

To avoid personal injury or death:

- Be sure brake pedals have equal adjustment when using locked together. Incorrect or unequal brake pedal adjustment can cause the tractor to swerve or roll-over.

1. Inspect the brake and clutch pedals for free travel, and smooth operation.
2. Adjust if incorrect measurement is found: (See "Adjusting Clutch Pedal" and "Adjusting Brake Pedal" in "EVERY 100 HOURS" in "PERIODIC SERVICE" section.)

■ Checking Gauges, Meter and Easy Checker(TM)

1. Inspect the instrument panel for broken gauge(s), meter(s) and Easy Checker (TM).
2. Replace if broken.

■ Checking Head Light, Turn Signal / Hazard Light etc.

1. Inspect the lights for broken bulbs and lenses.
2. Replace if broken.

■ Checking Seat Belt and ROPS

1. Always check condition of seat belt and ROPS attaching hardware before operating tractor.
2. Replace if damaged.

■ Checking Movable Parts

If any of the movable parts, such as levers and pedals, is not smoothly moved because of rust or sticky material, do not attempt to force it into motion.

In the above case, remove the rust or the sticky material, and apply oil or grease on the relevant spot.

Otherwise, the machine may get damaged.

EVERY 50 HOURS

■ Lubricating Grease Fittings

Apply a small amount of multipurpose grease to the following points every 50 hours:

If you operated the machine in extremely wet and muddy conditions, lubricate grease fittings more often.

When apply grease to forward front axle support, remove the breather plug and apply grease until grease overflows from breather plug port.

After greasing reinstall the breather plug.

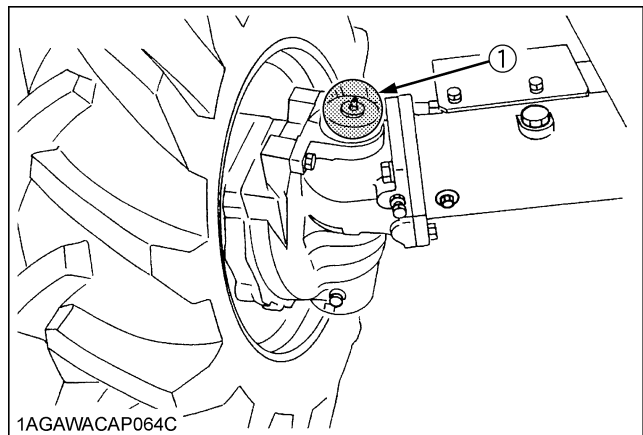

(1) Grease fitting (Front wheel case support)[RH, LH]

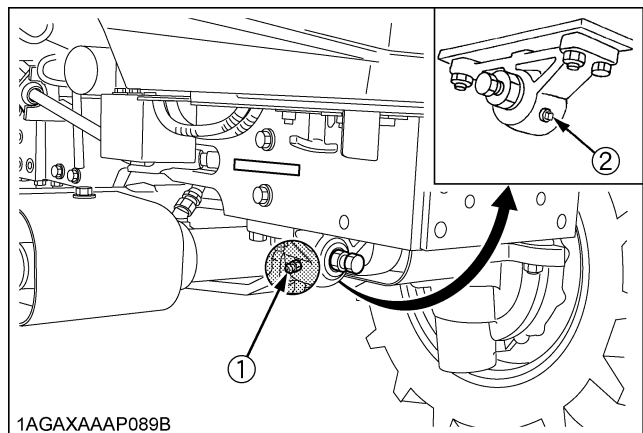

(1) Grease fitting (Front axle support)
(2) Breather plug

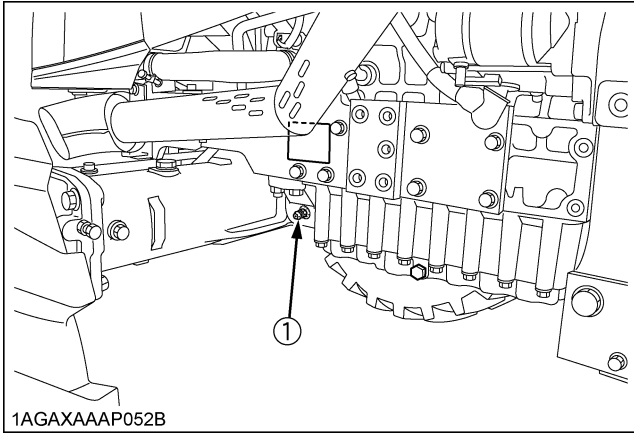

(1) Grease fitting (Front axle support)

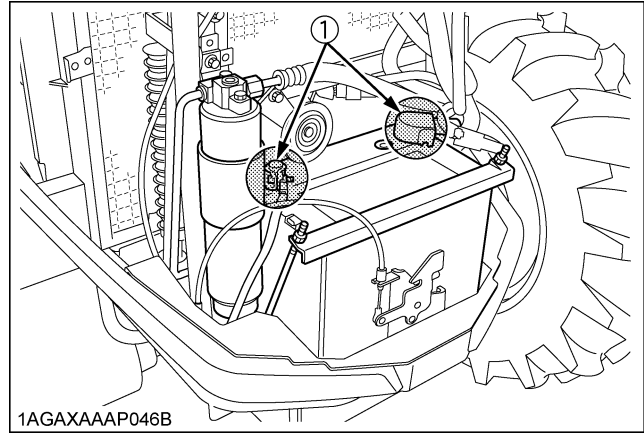

(1) Battery terminals

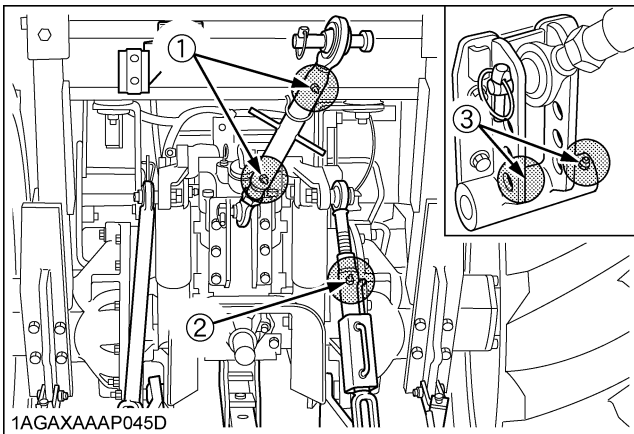

(1) Grease fitting (Top link)
 (2) Grease fitting (Lifting rod) [RH]
 (3) Grease fitting (Top link bracket)

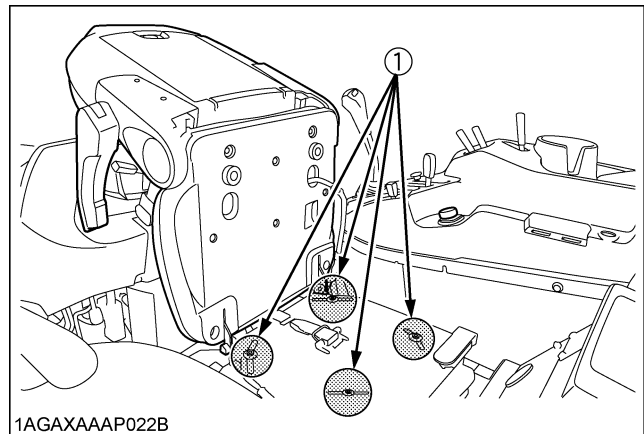

(1) Swivel seat

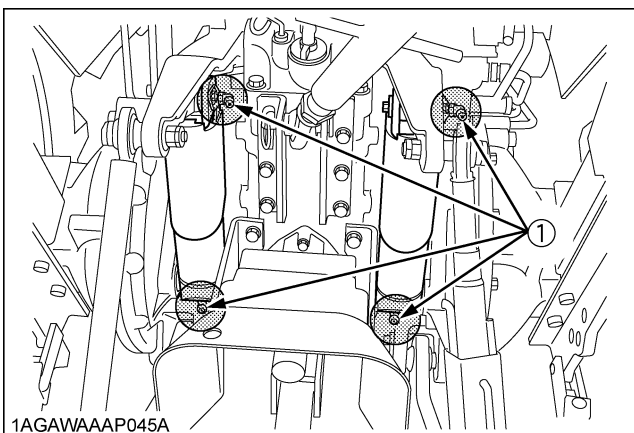

(1) Grease fitting (Lift cylinder)

■ Checking Engine Start System

⚠ WARNING

To avoid personal injury or death:

- Do not allow anyone near the tractor while testing.
- If the tractor does not pass the test, do not operate the tractor.

◆ Preparation before testing.

1. Place all control levers in the "NEUTRAL" position.
2. Set the parking brake and stop the engine.

[GST / Manual Transmission Type]

◆ Test: Switch for the shuttle shift lever.

1. Sit on the operator's seat
2. Shift the shuttle shift lever to the forward or reverse position.
3. Depress the clutch pedal fully.
4. Disengage the PTO clutch control switch or lever.
5. Turn the key to "START" position.
6. The engine must not crank.

- If it cranks, consult your local KUBOTA Dealer for this service.

◆ **Test: Switch for the PTO clutch control switch or lever.**

- Sit on the operator's seat.
- Engage the PTO clutch control switch or lever.
- Depress the clutch pedal fully.
- Shift the shuttle shift lever to the neutral position.
- Turn the key to "START" position.
- The engine must not crank.
- If it cranks, consult your local KUBOTA Dealer for this service.

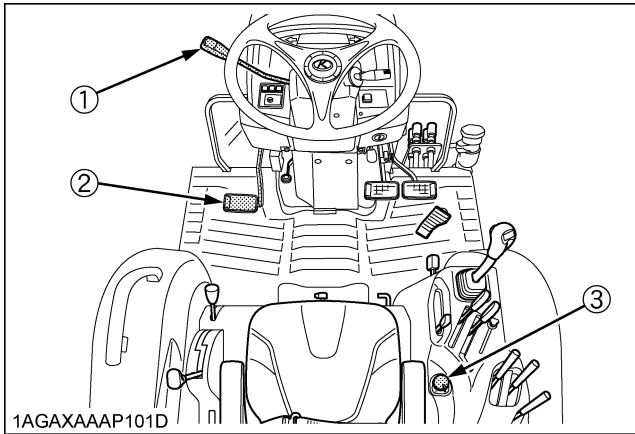

- Shuttle shift lever
- Clutch pedal
- PTO clutch control switch

[HST Type]

◆ **Test: Switch for the speed control pedal.**

- Sit on the operator's seat.
- Depress the speed control pedal to the desired direction.
- Disengage the PTO clutch control switch or lever.
- Turn the key to "START" position.
- The engine must not crank.
- If it cranks, consult your local KUBOTA Dealer for this service.

◆ **Test: Switch for the PTO clutch control switch or lever.**

- Sit on the operator's seat.
- Engage the PTO clutch control switch or lever.
- Place the speed control pedal in neutral position.
- Turn the key to "START" position.
- The engine must not crank.
- If it cranks, consult your local KUBOTA Dealer for this service.

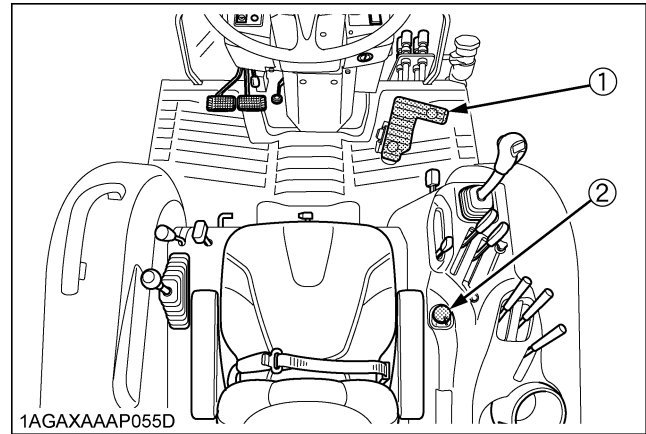

- Speed control pedal
- PTO clutch control switch

■ **Checking Operator Presence Control**

WARNING

To avoid personal injury or death:

- Do not allow anyone near the tractor while testing.
- If the tractor does not pass the test, do not operate the tractor.

◆ **Preparation before testing.**

- Place all control levers in the "NEUTRAL" position.
- Set the parking brake and stop the engine.

◆ **Test: Switch for the operator's seat**

- Sit on the operator's seat.
- Start the engine.
- Engage the PTO clutch control switch or lever.
- Stand up. (Do not get off the machine.)
- The engine must shut off after approximately 1 second.
- If it does not stop, consult your local KUBOTA Dealer for this service.

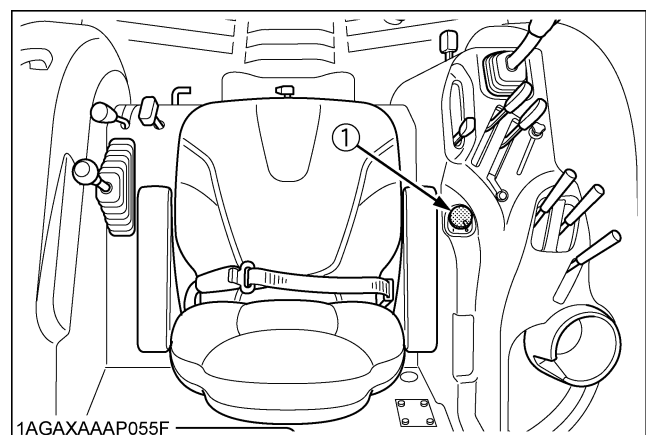

- PTO clutch control switch

■ Checking Wheel Bolt Torque



WARNING

To avoid personal injury or death:

- Never operate tractor with a loose rim, wheel, or axle.
- Any time bolts and nuts are loosened, retighten to specified torque.
- Check all bolts and nuts frequently and keep them tight.

Check wheel bolts and nuts regularly especially when new. If they are loose, tighten them as follows.

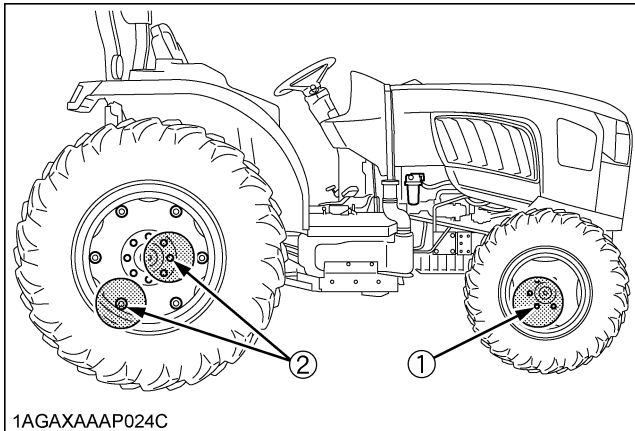

- (1) [L3560, L4060, L4760]
137 N-m (14 kgf-m, 100 ft-lbs)
[L5060, L5460, L6060]
185 N-m (19 kgf-m, 136 ft-lbs)
- (2) 215 N-m (22 kgf-m, 160 ft-lbs)

EVERY 100 HOURS

■ Cleaning Air Cleaner Primary Element

1. Remove the air cleaner cover and primary element.
2. Clean the primary element:
 - (1) When dry dust adheres to the element, blow compressed air from the inside, turning the element. Pressure of compressed air must be under 205 kPa (2.1 kgf/cm², 30 psi).
 - (2) When carbon or oil adheres to the element, soak the element in detergent for 15 minutes then wash it several times in water, rinse with clean water and dry it naturally. After element is fully dried, inspect inside of the element with a light and check if it is damaged or not.
3. Replace air cleaner primary element:
Once every 1000 hours or yearly, whichever comes first.

NOTE :

- Check to see if the evacuator valve is blocked with dust.

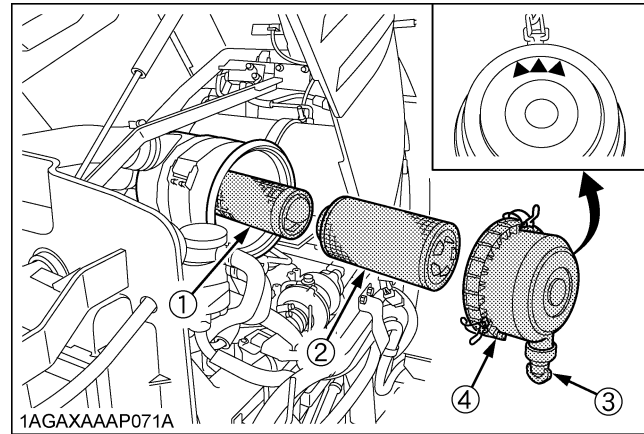

- (1) Secondary (safety) element
(2) Primary element
(3) Evacuator valve
(4) Cover

IMPORTANT :

- The air cleaner uses a dry element, never apply oil.
- Do not run the engine with filter element removed.
- Be sure to refit the cover with the arrow ↑ (on the rear of cover) upright. If the cover is improperly fitted, evacuator valve will not function and dust will adhere to the element.
- Do not touch the secondary element except in cases where replacing is required.
(See "Replacing Air Cleaner Secondary Element" in "EVERY 1000 HOURS or 1 YEAR" in "PERIODIC SERVICE" section.)

◆ Evacuator Valve

Open the evacuator valve once a week under ordinary conditions - or daily when used in a dusty place - to get rid of large particles of dust and dirt.

■ Adjusting Fan Belt Tension



WARNING

To avoid personal injury or death:

- Be sure to stop the engine before checking belt tension.

Proper fan belt tension	A deflection of between 7 to 9 mm (0.28 to 0.34 in.) when the belt is pressed in the middle of the span.
-------------------------	--

1. Stop the engine and remove the key.
2. Apply moderate thumb pressure to belt between pulleys.
3. If tension is incorrect, loosen the alternator mounting bolts and, using a lever placed between the alternator and the engine block, pull the alternator out until the deflection of the belt falls within acceptable limits.
4. Replace fan belt if it is damaged.

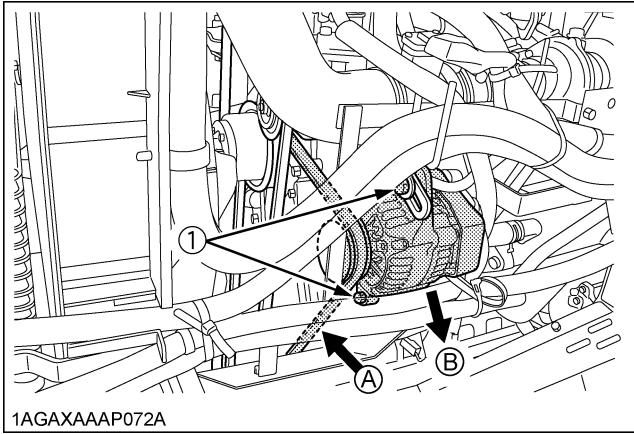

(1) Bolt
 (A) Check the belt tension
 (B) To tighten

■ Adjusting Clutch Pedal

[GST / Manual Transmission Type]

Proper clutch pedal free travel	20 to 30 mm (0.8 to 1.2 in.) on the pedal
---------------------------------	---

◆ Adjusting procedure

1. Stop the engine and remove the key.
2. Slightly depress the clutch pedal and measure free travel at top of pedal stroke.
3. If adjustment is needed, loosen the lock nut, remove the clevis pin and adjust the rod length within acceptable limits.
4. Retighten the lock nut and split the cotter pin.

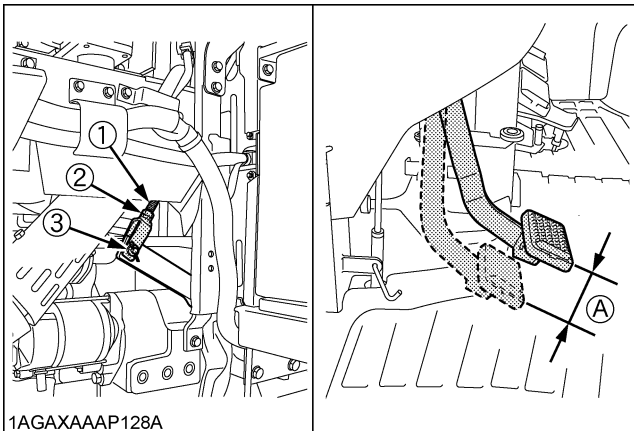

(1) Clutch rod
 (2) Nut
 (3) Clevis pin
 (A) "FREE TRAVEL"

■ Adjusting Brake Pedal

⚠ WARNING

To avoid personal injury or death:

- Stop the engine and chock the wheels before checking brake pedal.

Proper brake pedal free travel	15 to 20 mm (0.6 to 0.8 in.) on the pedal
	Keep the free travel in the right and left brake pedals equal.

◆ Adjusting procedure

1. Release the parking brake.
2. Slightly depress the brake pedals and measure free travel at the top of pedal stroke.
3. If adjustment is needed, loosen the lock nut and turn the turnbuckle to adjust the rod length within acceptable limits.
4. Retighten the lock nut.

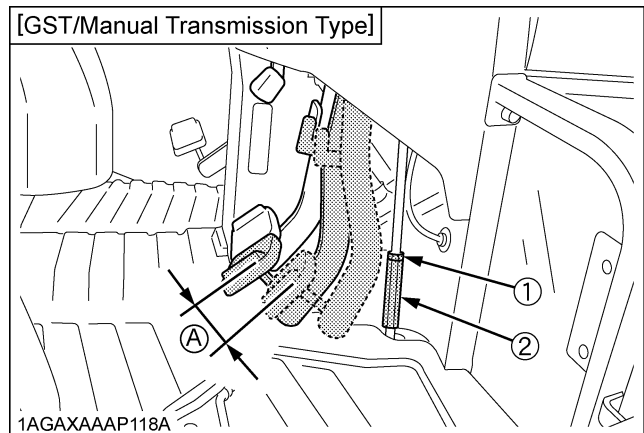
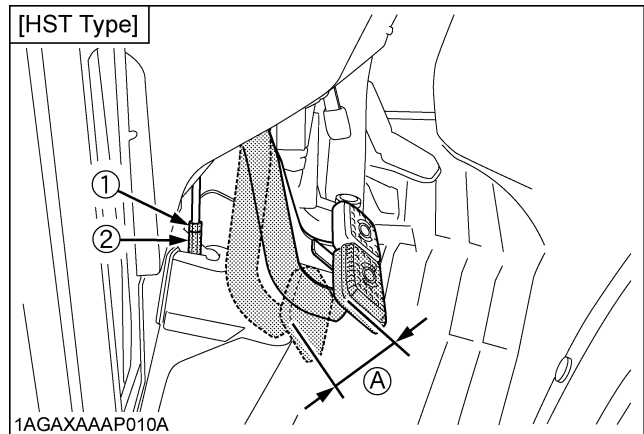

(1) Lock nut
 (2) Turnbuckle
 (A) "FREE TRAVEL"

■ Checking Battery Condition



DANGER

To avoid the possibility of battery explosion:
For the refillable type battery, follow the instructions below.

- Do not use or charge the refillable type battery if the fluid level is below the LOWER (lower limit level) mark. Otherwise, the battery component parts may prematurely deteriorate, which may shorten the battery's service life or cause an explosion. Check the fluid level regularly and add distilled water as required so that the fluid level is between the UPPER and LOWER levels.



WARNING

To avoid personal injury or death:

- Never remove the battery cap while the engine is running.
- Keep electrolyte away from eyes, hands and clothes. If you are splattered with it, wash it away completely with water immediately and get medical attention.
- Keep open sparks and flames away from the battery at all times. Hydrogen gas mixed with oxygen becomes very explosive.
- Wear eye protection and rubber gloves when working around battery.

The factory-installed battery is of non-refillable type. If the indicator turns white, do not charge the battery but replace it with new one.

Mishandling the battery shortens the service life and adds to maintenance costs.

The original battery is maintenance free, but needs some servicing.

If the battery is weak, the engine will be difficult to start and the lights will be dim. It is important to check the battery periodically.

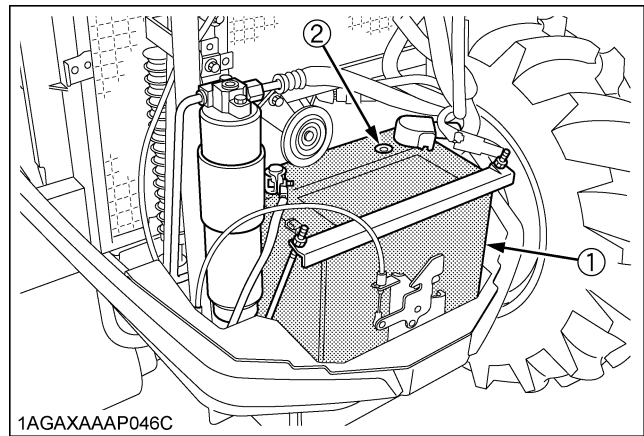

(1) Battery
(2) Indicator

◆ How to read the indicator

Check the battery condition by reading the indicator.

State of indicator display	
Green	Specific gravity of electrolyte and quality of electrolyte are both in good condition.
Black	Needs charging battery.
White	Needs replacing battery.

◆ Battery Charging



WARNING

To avoid personal injury or death:

- When the battery is being activated, hydrogen and oxygen gases in the battery are extremely explosive. Keep open sparks and flames away from the battery at all times, especially when charging the battery.
- When charging the battery, ensure the vent caps are securely in place. (if equipped)
- When disconnecting the cable from the battery, start with the negative terminal first. When connecting the cable to the battery, start with the positive terminal first.
- Never check battery charge by placing a metal object across the posts. Use a voltmeter or hydrometer.

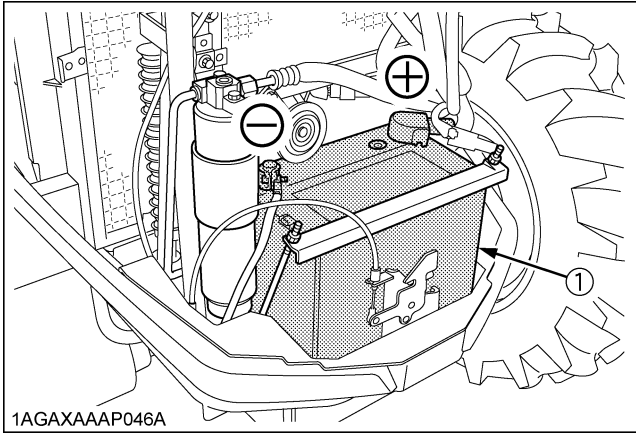

1AGAXAAP046A

(1) Battery

1. To slow charge the battery, connect the battery positive terminal to the charger positive terminal and the negative to the negative, then recharge in the standard fashion.
2. A boost charge is only for emergencies. It will partially charge the battery at a high rate and in a short time. When using a boost-charged battery, it is necessary to recharge the battery as early as possible. Failure to do this will shorten the battery's service life.
3. The battery is charged if the indicator display turns green from black.
4. When exchanging an old battery for a new one, use battery of equal specification shown in **table 1**.

Table 1

Battery Type	Volts (V)	Capacity at 5H.R(A.H)
80D26R	12	55
Reserve Capacity (min)	Cold Cranking Amps	Normal Charging Rate (A)
133	582	6.5

◆ **Direction for Storage**

1. When storing the tractor for long periods of time, remove the battery from tractor, adjust the electrolyte to the proper level and store in a dry place out of direct sunlight.
2. The battery self-discharges while it is stored. Recharge it once every 3 months in hot seasons and once every 6 months in cold seasons.

EVERY 200 HOURS

■ **Replacing Transmission Oil Filter [HST Type]**

⚠ WARNING

To avoid personal injury or death:

- Be sure to stop the engine before changing the oil filter cartridge.
- Allow engine to cool down sufficiently, oil can be hot and can burn.

1. Place the oil pan underneath the transmission oil filter and remove the filter.
Do not remove the hydraulic oil filter. Otherwise, the oil comes out.

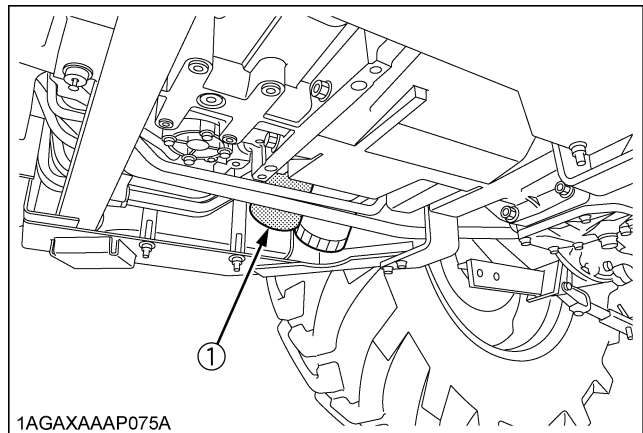

1AGAXAAP075A

(1) Transmission oil filter [HST Type]

2. Put a film of clean transmission oil on the rubber seal of the new filter.
3. Quickly tighten the filter until it contacts the mounting surface, then, with a filter wrench, tighten it an additional 1 turn only.
4. After the new filter has been replaced, fill the transmission oil up to the upper notch on the dipstick.

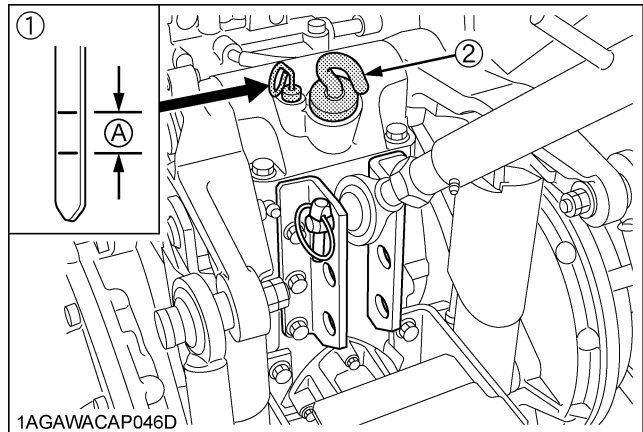

1AGAWACAP046D

- (1) Gauge (A) Oil level is acceptable within this range.
(2) Oil inlet

5. After running the engine for a few minutes, stop the engine and check the oil level again, add oil to the prescribed level.
6. Make sure that the transmission fluid doesn't leak past the seal on the filter.

IMPORTANT :

- To prevent serious damage to the hydraulic system, use only a KUBOTA genuine filter.
- Do not operate the tractor immediately after changing the transmission fluid.
Run the engine at medium speed for a few minutes to prevent damage to the transmission.

■ Adjusting Toe-in

Proper toe-in	2 to 8 mm (0.08 to 0.31 in.)
---------------	------------------------------

1. Park tractor on a flat place.
2. Turn steering wheel so front wheels are in the straight ahead position.
3. Lower the implement, lock the park brake and stop the engine.
4. Measure distance between tire beads at front of tire, at hub height.
5. Measure distance between tire beads at rear of tire, at hub height.
6. Front distance should be shorter than rear distance. If not, adjust tie rod length.

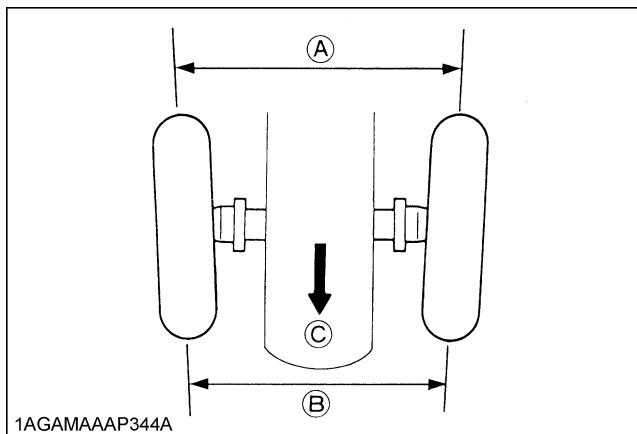

(A) Wheel - to - wheel distance at rear
 (B) Wheel - to - wheel distance at front
 (C) "FRONT"

◆ Adjusting procedures

1. Loosen the tie-rod nut.
2. Turn the tie-rod joint to adjust the rod length until the proper toe-in measurement is obtained.
3. Retighten the tie-rod nut.

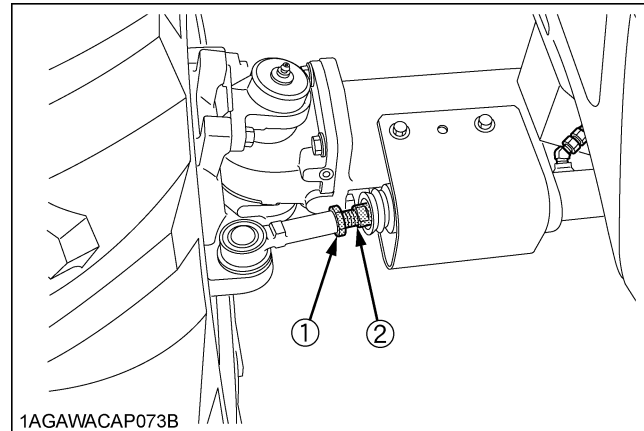

(1) Tie-rod nut
 (2) Tie-rod joint

EVERY 400 HOURS

■ Changing Engine Oil



WARNING

To avoid personal injury or death:

- Be sure to stop the engine before changing the oil.
- Allow engine to cool down sufficiently, oil can be hot and can burn.

1. To drain the used oil, remove the drain plug at the bottom of the engine and drain the oil completely into the oil pan.
All the used oil can be drained out easily when the engine is still warm.
2. After draining reinstall the drain plug.
3. Fill with the new oil up to the upper notch on the dipstick.
(See "LUBRICANTS" in "MAINTENANCE" section.)

Oil capacity with filter	L3560	6.7 L (7.1 U.S.qts.)
	L4060, L4760	8.2 L (8.7 U.S.qts.)
	L5060, L5460, L6060	9.4 L (9.9 U.S.qts.)

IMPORTANT :

- Use DPF-compatible oil (CJ-4) for the engine.

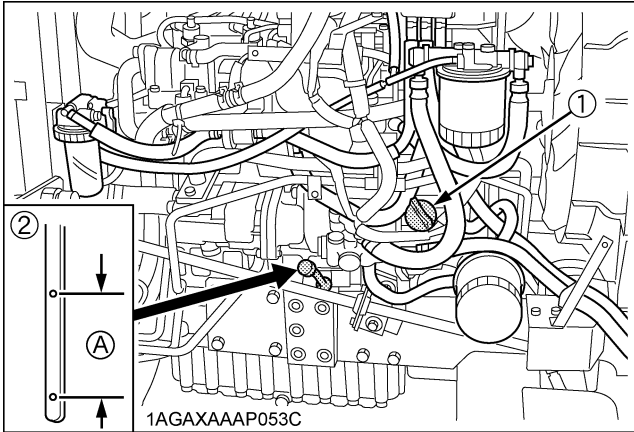

(1) Oil inlet (A) Oil level is acceptable within this range
(2) Dipstick

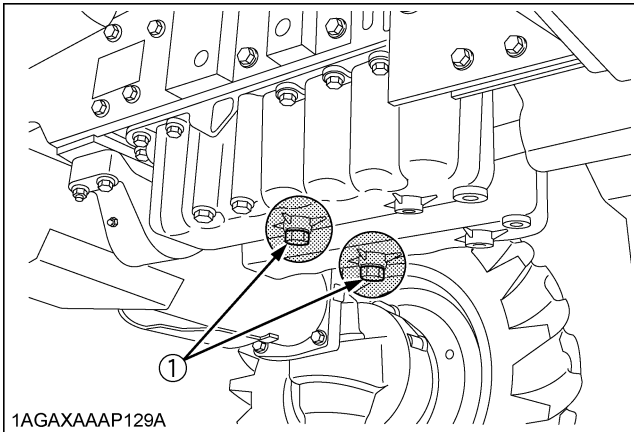

(1) Drain plug

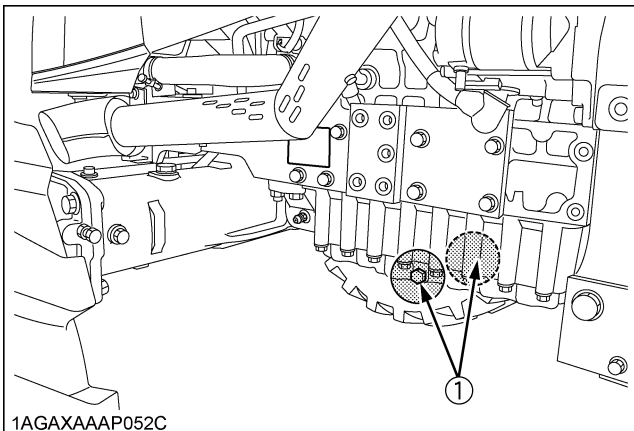

(1) Drain plug

Replacing Engine Oil Filter



WARNING

To avoid personal injury or death:

- Be sure to stop the engine before replacing the oil filter cartridge.
- Allow engine to cool down sufficiently, oil can be hot and can burn.

1. Remove the oil filter.
2. Put a film of clean engine oil on the rubber seal of the new filter.
3. Tighten the filter quickly until it contacts the mounting surface.
Tighten filter by hand an additional 1/2 turn only.
4. After the new filter has been replaced, the engine oil normally decreases a little. Make sure that the engine oil does not leak through the seal and be sure to check the oil level on the dipstick. Then, replenish the engine oil up to the prescribed level.

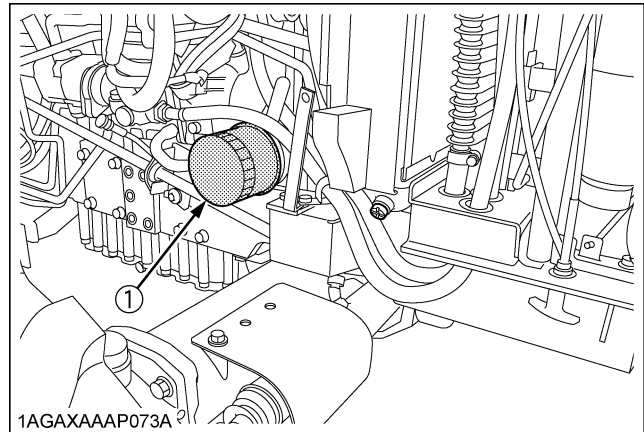

(1) Engine oil filter

IMPORTANT :

- To prevent serious damage to the engine, use only a KUBOTA genuine filter.

Changing Transmission Fluid / Replacing Hydraulic Oil Filter

◆ **Cleaning Magnetic Filter**



WARNING

To avoid personal injury or death:

- Be sure to stop the engine before changing the oil filter cartridge.
- Allow engine to cool down sufficiently, oil can be hot and can burn.

1. Remove the drain plugs at the bottom of the transmission case and drain the oil completely into the oil pan.
2. After draining reinstall the drain plugs.

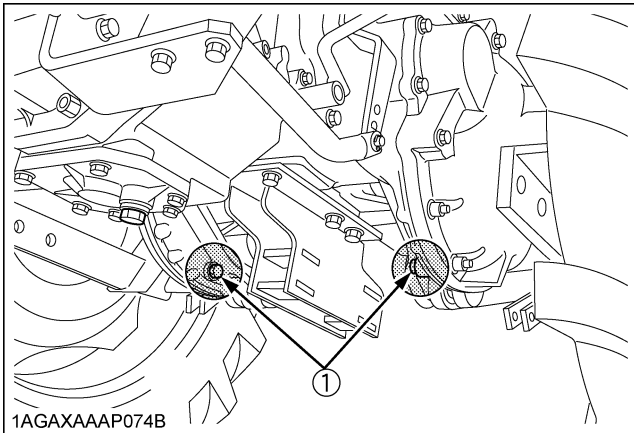

(1) Drain plugs

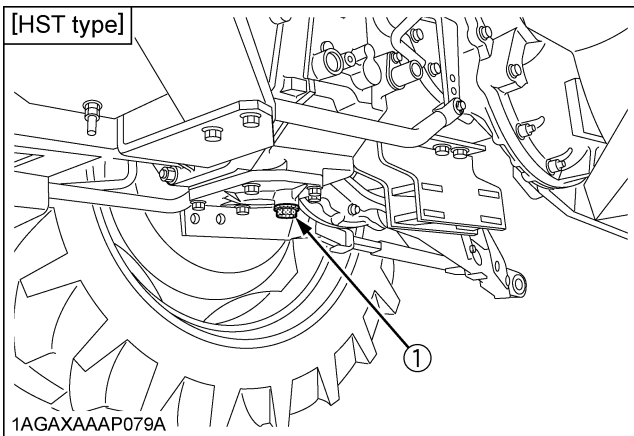

(1) Drain plug

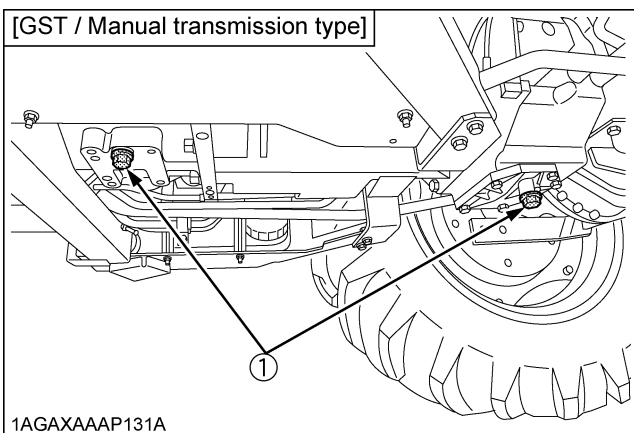

(1) Drain plugs

3. Remove the oil filter.
4. Wipe off metal filings from the magnetic filter with a clean rag.

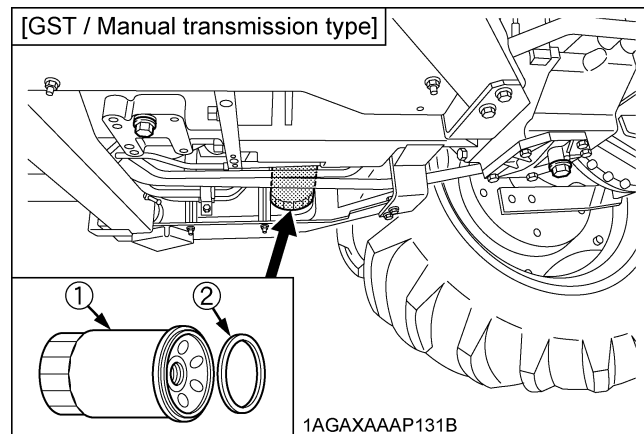
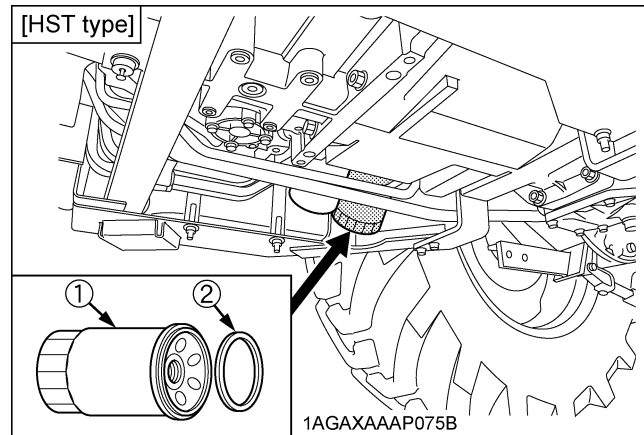

- (1) Hydraulic oil filter
- (2) Magnetic filter (Wipe off metal filings)

5. Put a film of clean transmission oil on the rubber seal of the new filter.
6. Quickly tighten the filter until it contacts the mounting surface, then tighten it by hand an additional 1/2 turn only.
7. Fill with the new KUBOTA SUPER UDT fluid up to the upper notch on the dipstick.
(See "LUBRICANTS" in "MAINTENANCE" section.)
8. After running the engine for a few minutes, stop the engine and check the oil level again, add oil to the prescribed level.
9. Make sure that the transmission fluid doesn't leak past the seal on the filter.

Oil Capacity	L3560	42 L (11.1 U.S.gals.)
	L4060, L4760	43 L (11.4 U.S.gals.)
	L5060, L5460, L6060	45 L (11.9 U.S.gals.)

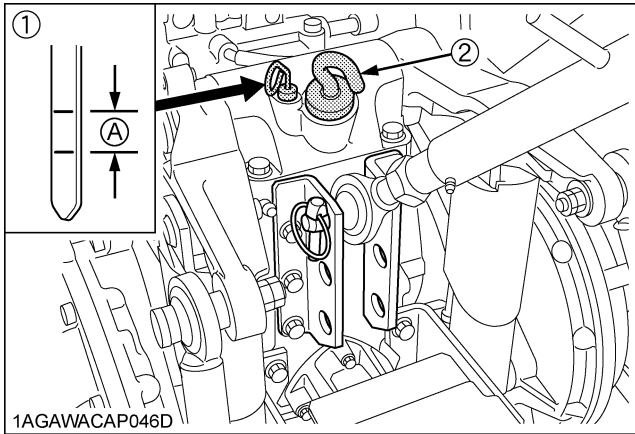

(1) Gauge (A) Oil level is acceptable within this range.
 (2) Oil inlet

IMPORTANT :

- To prevent serious damage to the hydraulic system, use only a KUBOTA genuine filter.
- Do not operate the tractor immediately after changing the transmission fluid.
 Run the engine at medium speed for a few minutes to prevent damage to the transmission.

■ Changing Front Axle Case Oil

1. To drain the used oil, remove the right and left drain plugs and filling plug at the front axle case and let out the oil completely into the oil pan.
2. After draining, reinstall the drain plugs.
3. Gently pour new oil through the filling port. Required oil quantities are written in the table below. Make sure to pour the specified amounts. If oil overflows before pouring any of the specified amounts, wait a couple of minutes and try again.
 (See "LUBRICANTS" in "MAINTENANCE" section.)
4. After filling, reinstall the filling plug.
5. Run the vehicle a few minutes in order for the oil to flow through the front axle case.
6. Remove the oil level check plug and check to see if the oil flows out of its port. If not, add the oil through the filling port until it flows out of the oil level check port.
7. Reinstall and tighten the oil level check plug and filling plug.

Oil capacity	L3560, L4060	6.5 L (6.9 U.S.qts.)
	L4760, L5060, L5460, L6060	8.5 L (8.9 U.S.qts.)

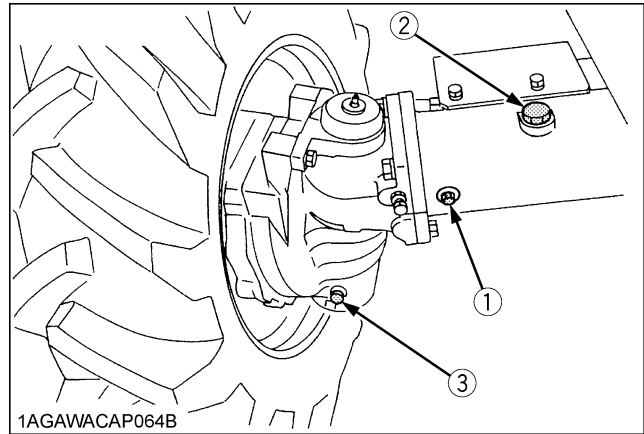

(1) Check plug
 (2) Filling plug
 (3) Drain plug

■ Replacing Fuel Filter

1. Remove the fuel filter.
2. Put a film of clean fuel on rubber seal of new filter.
3. Tighten the filter quickly until it contacts the mounting surface.
 Tighten filter by hand an additional 1/2 turn only.
4. Bleed the fuel system.
 (See "Bleeding Fuel System" in "SERVICE AS REQUIRED" in "PERIODIC SERVICE" section.)

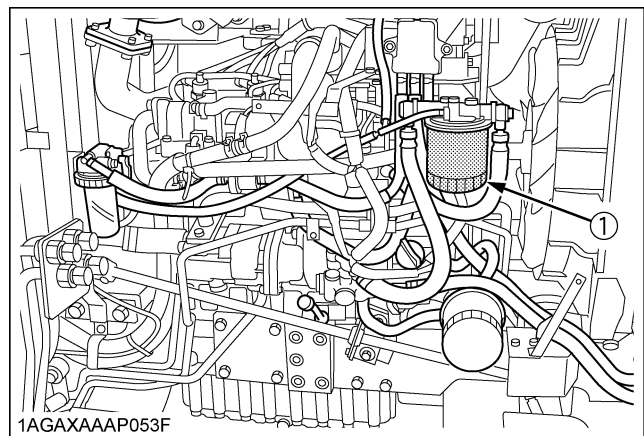

(1) Fuel filter

■ Cleaning Water Separator

This job should not be done in the field, but in a clean place.

1. Close the fuel cock.
2. Unscrew the retainer ring and remove the cup, and rinse the inside with kerosene.
3. Take out the element and dip it in the kerosene to rinse.
4. After cleaning, reassemble the water separator, keeping out dust and dirt.
5. Bleed the fuel system.

(See "Bleeding Fuel System" in "SERVICE AS REQUIRED" in "PERIODIC SERVICE" section.)

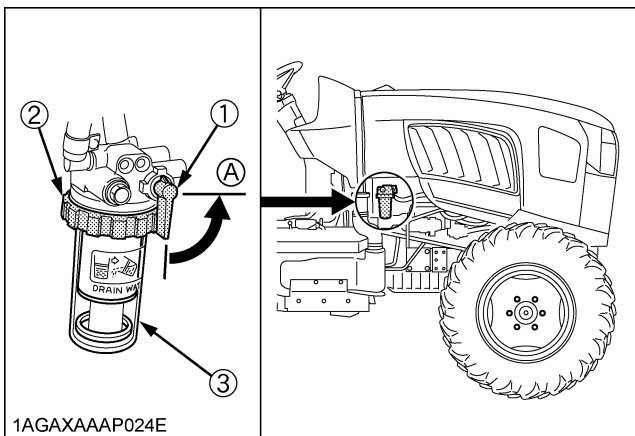

1AGAXAAP024E

- (1) Fuel cock
- (2) Retainer ring
- (3) Cup

(A) "CLOSE"

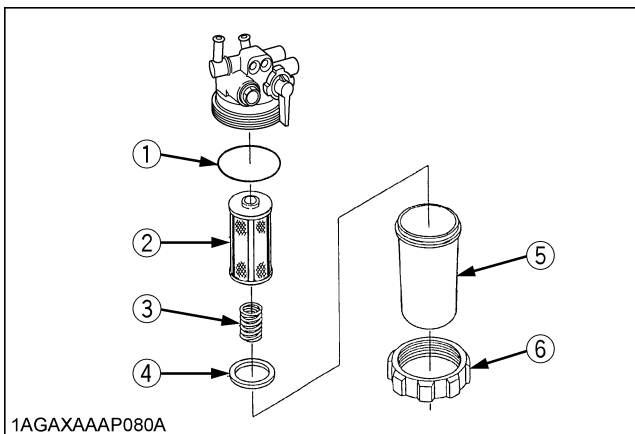

1AGAXAAP080A

- (1) O ring
- (2) Element
- (3) Spring
- (4) Red float
- (5) Cup
- (6) Retainer ring

EVERY 600 HOURS

■ Adjusting Front Axle Pivot

If the front axle pivot pin adjustment is not correct, front wheel vibration can occur causing vibration in the steering wheel.

◆ Adjusting procedure

Loosen the lock nut, screw-in the adjusting screw until seated, then tighten the screw with an additional 1/6 turn. Re-tighten the lock nut.

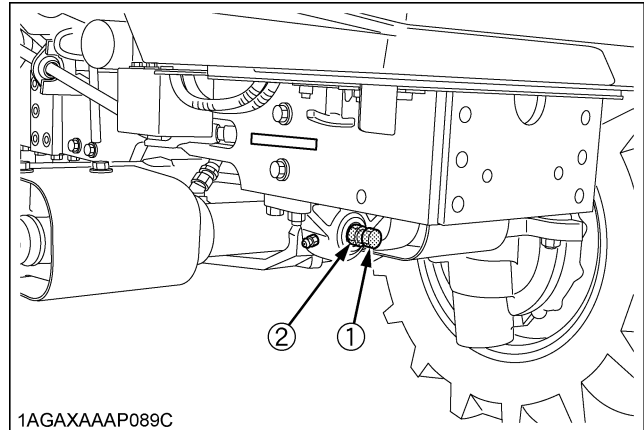

1AGAXAAP089C

- (1) Adjusting screw
- (2) Lock nut

EVERY 800 HOURS

■ Adjusting Engine Valve Clearance

Consult your local KUBOTA Dealer for this service.

EVERY 1000 HOURS or 1 YEAR

■ Replacing Air Cleaner Primary Element and Secondary Element

(See "Cleaning Air Cleaner Primary Element" in "EVERY 100 HOURS" in "PERIODIC SERVICE" section.)

■ Checking Exhaust Manifold

Consult your local KUBOTA Dealer for this service.

EVERY 1500 HOURS

■ Cleaning Fuel Injector Nozzle Tip

Consult your local KUBOTA Dealer for this service.

■ Replacing Oil Separator Element



WARNING

To avoid personal injury or death:

- Be sure to stop the engine before replacing the oil separator element.

1. Remove the cover and take out the element. Wipe off oil and the carbon in the case with a clean rag.
2. Fit a new oil separator element.
3. Tighten the cover.

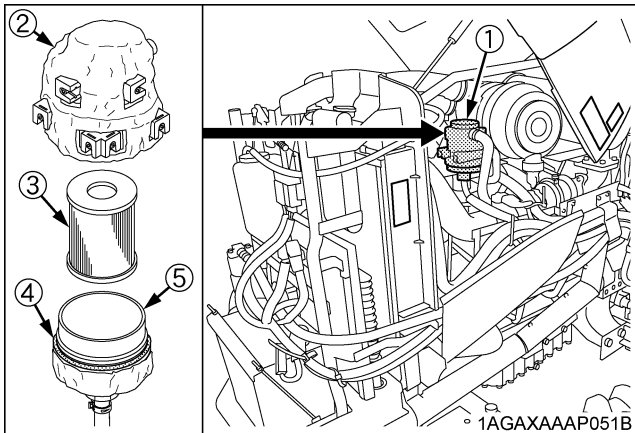

- (1) Oil separator
- (2) Body
- (3) Oil separator element
- (4) Gasket
- (5) Cover

■ Checking PCV (Positive Crankcase Ventilation) Valve

Consult your local KUBOTA Dealer for this service.

■ Checking and Cleaning EGR Cooler

Consult your local KUBOTA Dealer for this service.

EVERY 2000 HOURS or 2 YEARS

■ Flushing Cooling System and Changing Coolant



WARNING

To avoid personal injury or death:

- Do not remove radiator cap while coolant is hot. When cool, slowly rotate cap to the first stop and allow sufficient time for excess pressure to escape before removing the cap completely.

1. Stop the engine, remove the key and let it cool down.
2. To drain the coolant, open the radiator drain plug and remove radiator cap. The radiator cap must be removed to completely drain the coolant.
3. After all coolant is drained, reinstall the drain plug.
4. Fill with clean soft water and cooling system cleaner.
5. Follow directions of the cleaner instruction.
6. After flushing, fill with clean soft water and anti-freeze until the coolant level is just below the radiator cap. Install the radiator cap securely.
7. Fill with coolant up to the "FULL" mark of recovery tank.
8. Start and operate the engine for few minutes.
9. Stop the engine, remove the key and let cool.
10. Check coolant level of recovery tank and add coolant if necessary.
11. Properly dispose of used coolant.

Coolant capacity	L3560, L4060	7.5 L (7.9 U.S.qts.)
	L4760, L5060, L5460, L6060	8.2 L (8.7 U.S.qts.)

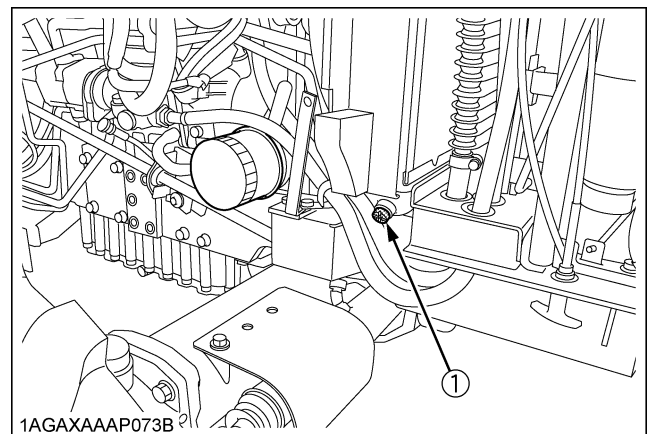

(1) Drain plug

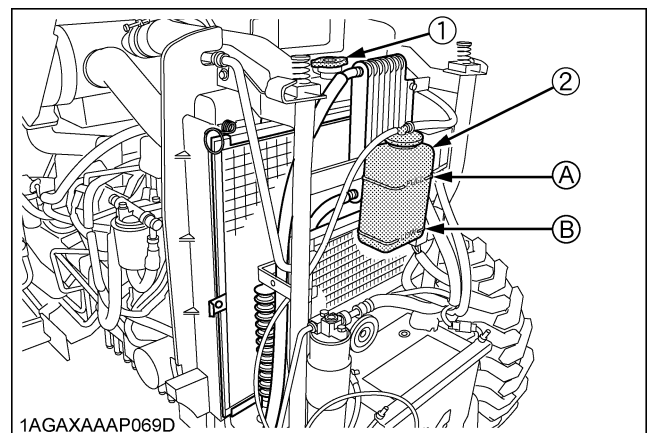

- (1) Radiator cap
- (2) Recovery tank
- (A) "FULL"
- (B) "LOW"

IMPORTANT :

- Do not start engine without coolant.
- Use clean, fresh soft water and anti-freeze to fill the radiator and recovery tank.
- When mixing the anti-freeze with water, the anti-freeze mixing ratio is 50 %.
- Securely tighten radiator cap. If the cap is loose or improperly fitted, water may leak out and the engine could overheat.

NOTE :

- On cab type machines, coolant circulates through the heater. This means that one more liter or so of coolant is required.

In changing coolant, pour coolant up to the filler port of the recovery tank. Turn ON the heater (shift the temperature control lever toward WARM), and run the engine for a while in order to warm coolant. Then stop the engine.

When coolant has cooled down, some of the coolant in the recovery tank is sucked. Now the recovery tank is appropriately filled with coolant.

■Anti-Freeze



WARNING

To avoid personal injury or death:

- **When using antifreeze, put on some protection such as rubber gloves. (Antifreeze contains poison.)**
- **If it is swallowed, seek immediate medical help. Do NOT make a person throw up unless told to do so by poison control or a health care professional. Use standard first aid and CPR for signs of shock or cardiac arrest. Call your local Poison Control Center or your local emergency number for further assistance.**
- **When antifreeze comes in contact with the skin or clothing, wash it off immediately.**
- **Do not mix different types of Antifreeze. The mixture can produce chemical reaction causing harmful substances.**
- **Antifreeze is extremely flammable and explosive under certain conditions. Keep fire and children away from antifreeze.**
- **When draining fluids from the engine, place some container underneath the engine body.**
- **Do not pour waste onto the ground, down a drain, or into any water source.**
- **Also, observe the relevant environmental protection regulations when disposing of antifreeze.**

Always use a 50/50 mix of long-life coolant and clean soft water in KUBOTA engines.

Consult your local KUBOTA Dealer concerning coolant for extreme conditions.

1. Long-life coolant (hereafter LLC) comes in several types. Use ethylene glycol (EG) type for this engine.
2. Before employing LLC-mixed cooling water, fill the radiator with fresh water and empty it again. Repeat this procedure 2 or 3 times to clean up the inside.
3. Mixing the LLC
Premix 50% LLC with 50% clean soft water. When mixing, stir it up well, and then fill into the radiator.
4. The procedure for the mixing of water and antifreeze differs according to the make of the antifreeze and the ambient temperature. Refer to SAE J1034 standard, more specifically also to SAE J814c.

Vol % Anti-freeze	Freezing Point		Boiling Point*	
	°C	°F	°C	°F
50	-37	-34	108	226

* At 1.013 x 10⁵Pa (760mmHg) pressure (atmospheric). A higher boiling point is obtained by using a radiator pressure cap which permits the development of pressure within the cooling system.

5. Adding the LLC
 - (1) Add only water if the mixture reduces in amount by evaporation.
 - (2) If there is a mixture leak, add the LLC of the same manufacturer and type in the same mixture percentage.
 - * Never add any long-life coolant of different manufacturer. (Different brands may have different additive components, and the engine may fail to perform as specified.)
6. When the LLC is mixed, do not employ any radiator cleaning agent. The LLC contains anticorrosive agent. If mixed with the cleaning agent, sludge may build up, adversely affecting the engine parts.
7. Kubota's genuine long-life coolant has a service life of 2 years. Be sure to change the coolant every 2000 hours or every 2 years whichever comes faster.

NOTE :

- The above data represent industry standards that necessitate a minimum glycol content in the concentrated antifreeze.

EVERY 3000 HOURS

■Checking Turbocharger

[L5060, L5460, L6060]

Consult your local KUBOTA Dealer for this service.

■Checking Supply Pump

Consult your local KUBOTA Dealer for this service.

■Checking and Cleaning EGR System

Consult your local KUBOTA Dealer for this service.

■ Cleaning DPF Muffler

◆ Removal of ash

The longer the DPF operates, the more ash (burnt residue) is collected in the filter. Too much ash build-up adversely affects the DPF performance. Consult your local KUBOTA Dealer to clean the filter.

IMPORTANT :

- The DPF needs cleaning with a specific cleaning device. Do not clean the DPF by disassembling, and attempt by yourself, consult your local KUBOTA Dealer.

EVERY 1 YEAR

■ Checking Fuel Line

1. Check to see that all lines and hose clamps are tight and not damaged.
2. If hoses and clamps are found worn or damaged, replace or repair them at once.

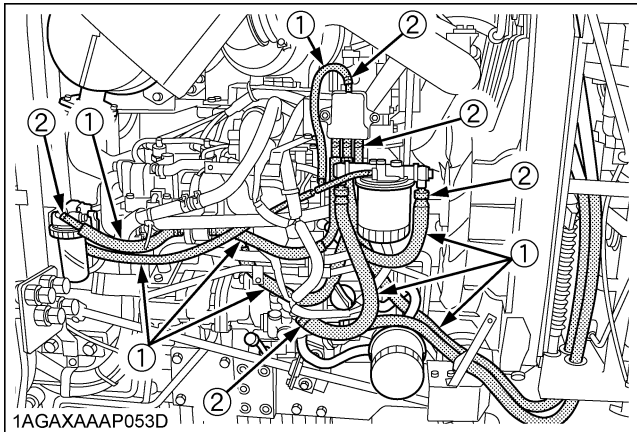

- (1) Fuel lines
- (2) Clamp bands

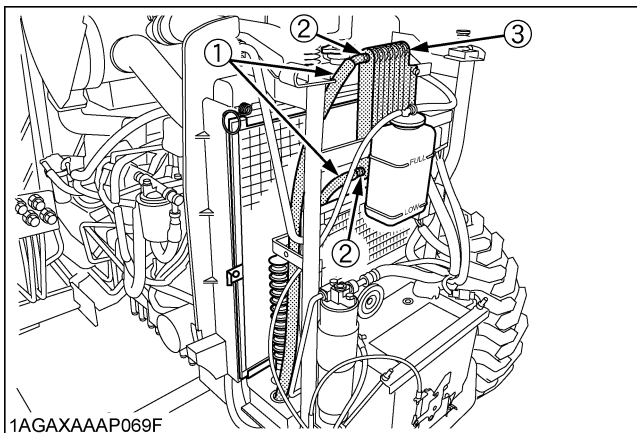

- (1) Fuel lines
- (2) Clamp bands
- (3) Fuel cooler

NOTE :

- If the fuel line is removed, be sure to properly bleed the fuel system.
(See "Bleeding Fuel System" in "SERVICE AS REQUIRED" in "PERIODIC SERVICE" section.)

■ Checking Intake Air Line

1. Check to see that hoses and hose clamps are tight and not damaged.
2. If hoses and clamps are found worn or damaged, replace or repair them at once.

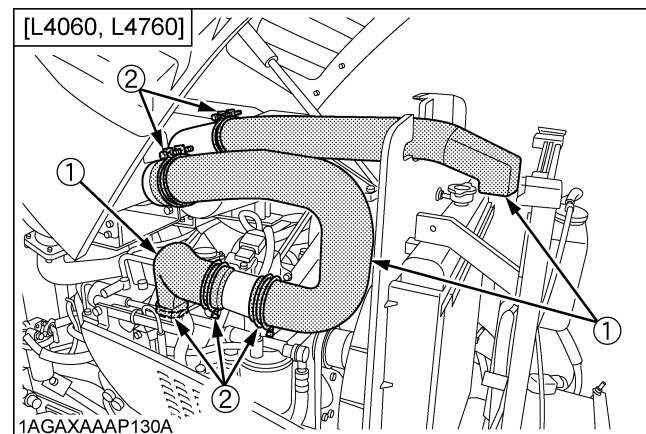
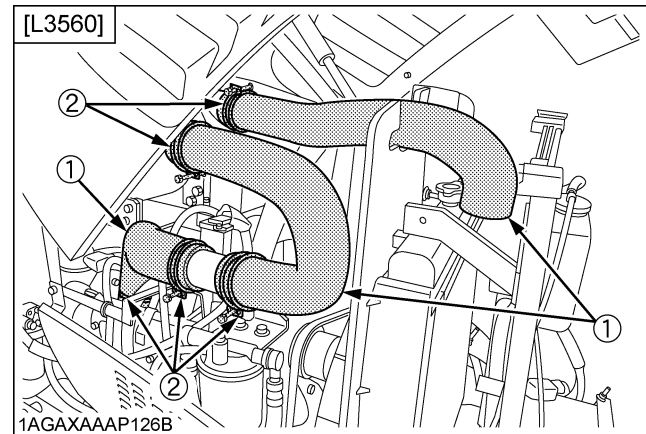

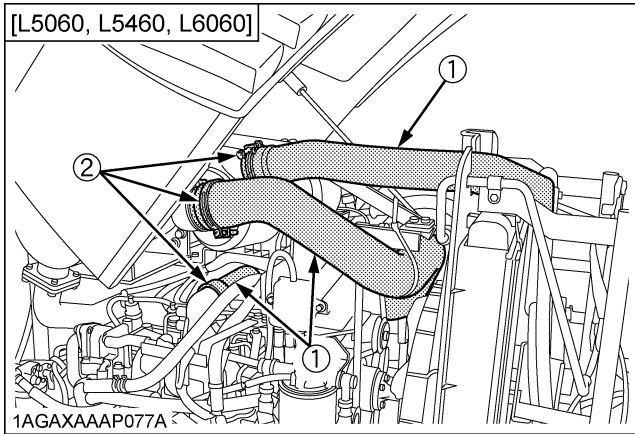

(1) Hose
(2) Hose clamps

■ Checking Radiator Hose and Clamp

Check to see if radiator hoses are properly fixed every year.

1. If hose clamps are loose or water leaks, tighten bands securely.
2. Replace hoses and tighten hose clamps securely, if radiator hoses are swollen, hardened or cracked.

Replace hoses and hose clamps every 4 years or earlier if checked and found that hoses are swollen, hardened or cracked.

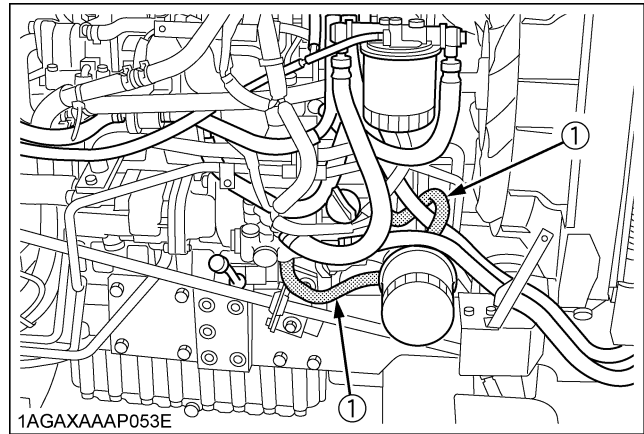
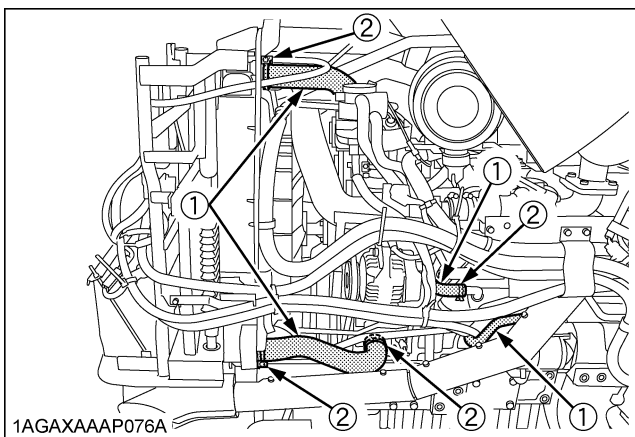

(1) Radiator hoses
(2) Clamp bands

◆ Precaution at Overheating

Take the following actions in the event the coolant temperature is nearly or more than the boiling point, what is called "Overheating"

1. Park the tractor in a safe place and keep the engine unloaded idling.
2. Don't stop the engine suddenly, but stop it after about 5 minutes of unloaded idling.
3. Keep yourself well away from the machine for further 10 minutes or while the steam blows out.
4. Check that there are no dangers such as burns. Get rid of the causes of overheating according to the manual, see "TROUBLESHOOTING" section, and then, start again the engine.

■ Checking Power Steering Line

1. Check to see that all lines and hose clamps are tight and not damaged.
2. If hoses and clamps are found worn or damaged, replace or repair them at once.

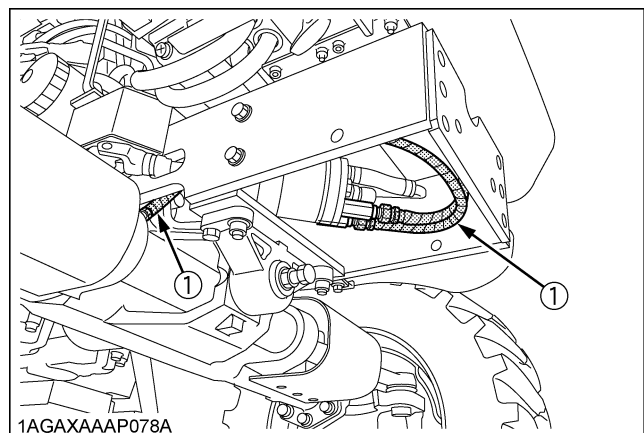

(1) Power steering pressure hoses

■Checking Oil Cooler Line [HST Type]

1. Check to see that all lines and hose clamps are tight and not damaged.
2. If hoses and clamps are found worn or damaged, replace or repair them at once.

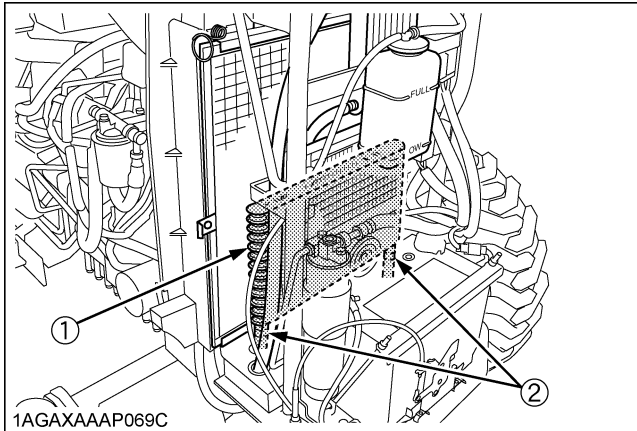

(1) Oil cooler
(2) Oil cooler line

■Checking Oil Separator Hose

1. Check to see that all hoses and hose clamps are tight and not damaged.
2. If hoses and clamps are found worn or damaged, replace or repair them at once.

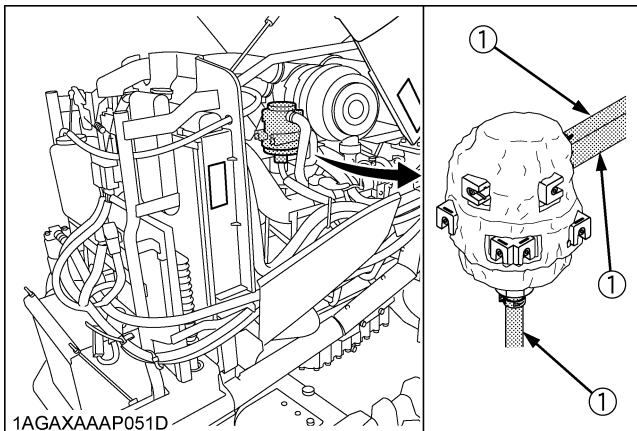

(1) Oil separator hoses

■Checking Antifrost Heater for Oil Separator

(if equipped)

Consult your local KUBOTA Dealer for this service.

■Checking Lift Cylinder Hose

1. Check to see that hoses and hose clamps are tight and not damaged.
2. If hoses and clamps are found worn or damaged, replace or repair them at once.

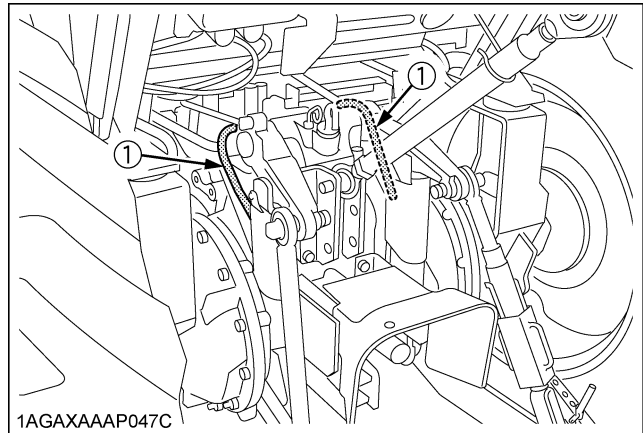

(1) Lift cylinder hoses

■Checking DPF Differential Pressure Sensor Pipe

Consult your local KUBOTA Dealer for this service.

■Checking EGR Pipe

Consult your local KUBOTA Dealer for this service.

EVERY 2 YEARS

■Replacing DPF Differential Pressure Sensor Hose

Consult your local KUBOTA Dealer for this service.

■Replacing Boost Sensor Hose

Consult your local KUBOTA Dealer for this service.

EVERY 4 YEARS

■Replacing Radiator Hose (Water pipes)

Replace the hoses and clamps.

(See "Checking Radiator Hose and Clamp" in "EVERY 1 YEAR" in "PERIODIC SERVICE" section.)

■Replacing Fuel Hose

Consult your local KUBOTA Dealer for this service.

■Replacing Intake Air Line

Consult your local KUBOTA Dealer for this service.

■ **Replacing Oil Cooler Line [HST Type]**

Consult your local KUBOTA Dealer for this service.

■ **Replacing Oil Separator Hose**

Consult your local KUBOTA Dealer for this service.

■ **Replacing Power Steering Hose**

Consult your local KUBOTA Dealer for this service.

■ **Replacing Lift Cylinder Hose**

Consult your local KUBOTA Dealer for this service.

SERVICE AS REQUIRED

■ **Bleeding Fuel System**

Air must be removed:

1. When the fuel filter or lines are removed.
2. When water is drained from water separator.
3. When tank is completely empty.
4. After the tractor has not been used for a long period of time.

◆ **Bleeding procedure is as follows:**

1. Fill the fuel tank with fuel, and open the fuel shutoff-valve.

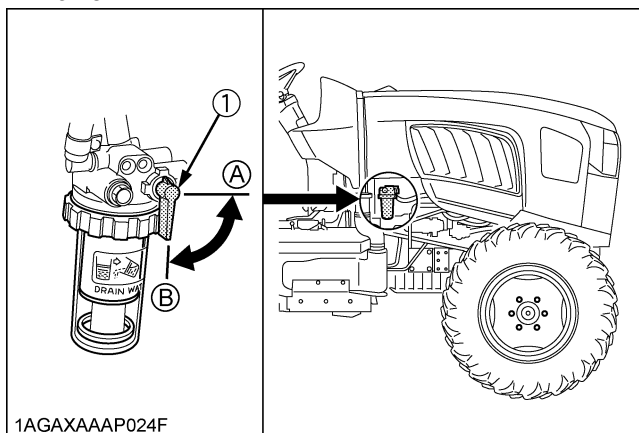

(1) Fuel shutoff-valve

(A) "CLOSE"

(B) "OPEN"

2. Loosen the air vent plug on the fuel filter 2 turns or so.

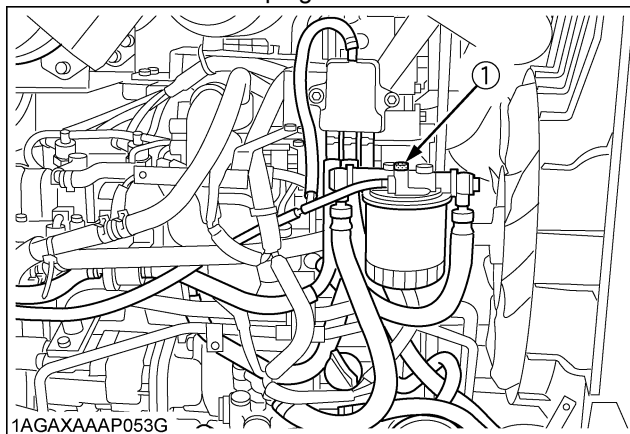

(1) Air vent plug

3. Turn on the key switch and wait for about 1 minute. Then tighten up the air vent plug.
4. Set the hand throttle lever at the minimum speed position and turn the key to "START" position. If the engine doesn't start, try it several times at 30 second intervals.

IMPORTANT :

- Do not hold key switch at engine start position for more than 10 seconds continuously. If more engine cranking is needed, try again after 30 seconds.
5. Accelerate the engine to remove the small portion of air left in the fuel system.
 6. If air still remains and the engine stops, repeat the above steps.

■ **Draining Clutch Housing Water**

The tractor is equipped with split pin plug under the clutch housing.

After operating in rain, snow or tractor has been washed, water may get into the clutch housing. Check it by pushing in the split pin.

If water has entered into the clutch housing, remove the plug and drain the water, then install the plug again.

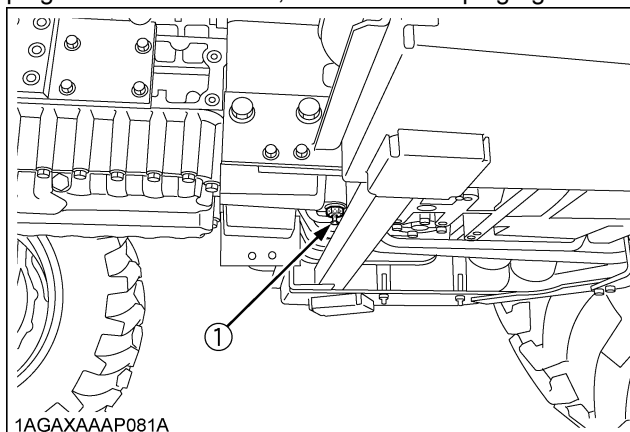

1AGAXAAP081A

(1) Split pin plug

■ Replacing Fuse

The tractor electrical system is protected from potential damage by fuses.

A blown fuse indicates that there is an overload or short somewhere in the electrical system.

If any of the fuses should blow, replace with a new one of the same capacity.

IMPORTANT :

- Before replacing a blown fuse, determine why the fuse blew and make any necessary repairs. Failure to follow this procedure may result in serious damage to the tractor electrical system. Refer to the "TROUBLESHOOTING" section of this manual or your local KUBOTA Dealer for specific information dealing with electrical problems.

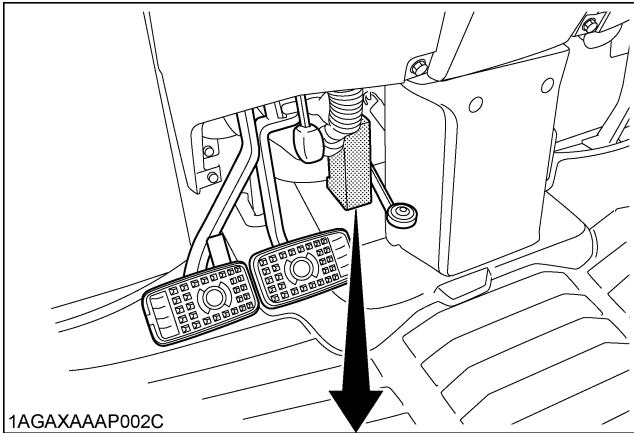

Fuse No.	Capacity (A)	Protected circuit	ROPS	CAB
(1)	5	Meter (Battery)	○	○
(2)	15	Hazard	○	---
	20	Hazard	---	○
(3)	5	Transmission Controller (Battery)	○	○
(4)	10	Radio (Battery)	---	○
(5)	20	Air conditioner blower	---	○
(6)	20	Engine ECU (Battery)	○	○
(7)	30	Starter relay	○	○
(8)	5	Engine ECU (IG)	○	○
(9)	20	Cigar lighter	---	○
(10)	5	Radio (ACC)	---	○
(11)	15	Transmission controller (IG)	○	○
(12)	10	Meter (IG)	○	○
(13)	5	Meter switch	○	○
(14)	30	Head light	○	○
(15)	7.5	Air conditioner compressor	---	○
(16)	30	Wiper	---	○
(17)	15	Flasher	○	○
(18)	10	Work light	○	---
	15	Work light	---	○

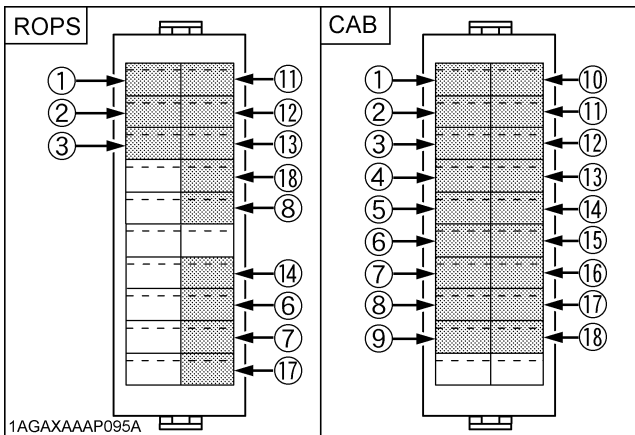

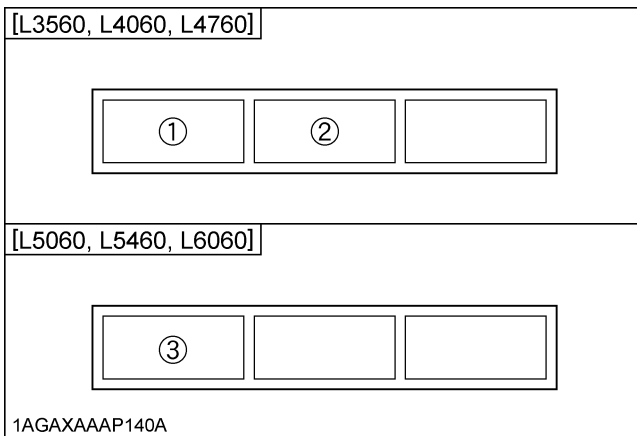
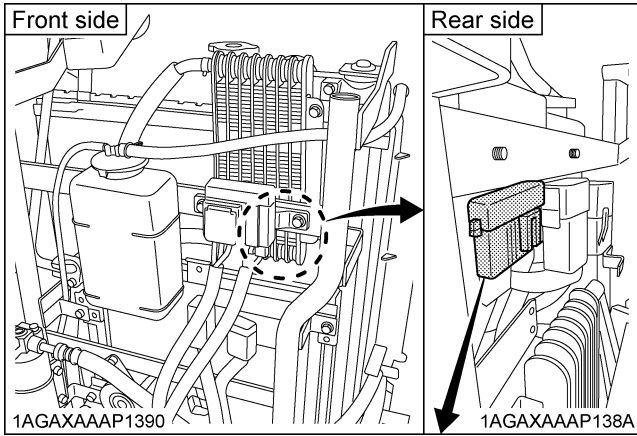

[Oil separator Fuse] (if equipped)

Fuse No.	Capacity (A)	Protected circuit
(1)	20	Heater (Oil separator, IN 1) Heater (Oil separator, IN 2)
(2)	20	Heater (Oil separator, OUT 1) Heater (Oil separator, OUT 2)
(3)	20	Heater (Oil separator, IN) Heater (Oil separator, OUT)

■ Replacing Slow-Blow Fuses

The slow-blow fuses are intended to protect the electrical cabling. If any of them has blown out, be sure to pinpoint the cause. Never use any substitute, use only a KUBOTA genuine part.

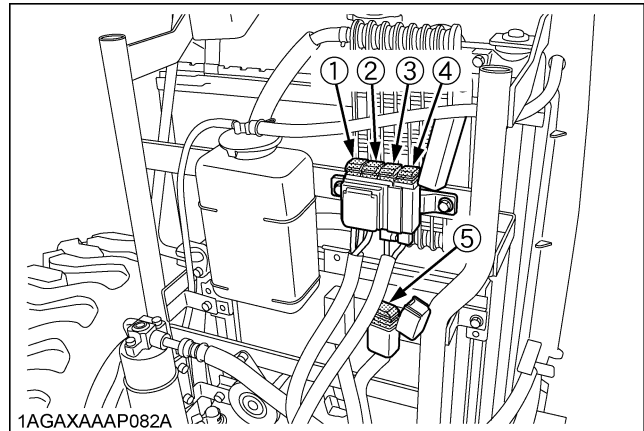

No.	Capacity (A)	Protected circuit
1	80	MAIN
2	60	BATTERY [CAB model]
3	60	KEY SW
4	50	GLOW
5	40	DEFOGGER [CAB model]

■ Replacing Light Bulb

Light	Capacity	
	ROPS	CAB
Head light	60 W / 55 W	
Tail light	5 W	
Hazard and Turn signal light (rear)	21 W	
Hazard and Turn signal light (front)	---	21 W
Side work light	21 W	
Room light	---	5 W
Work light	---	35 W

■ Replacing Head Lamp



CAUTION

To avoid personal injury:

- Be careful not to drop the bulb, hit anything against the lamp, apply excess force, and get the lamp scratched. If broken, glass may cause injury. Pay more attention to halogen lamps in particular, which have high pressure inside.
- Before replacing the lamp, be sure to turn off the light and wait until the bulb cools down, otherwise, you may get burned.

◆ Side work light

1. While pushing the lock button, pull and remove the electrical connector.
2. Turn the bulb counter-clockwise slightly and take out the bulb.
3. Replace with a new bulb and reinstall the side work light assembly in the reverse order.

◆ Head lamp

1. While pushing the right and left lock buttons, pull and remove the electrical connector.
2. Remove the rubber boot.
3. Remove the clamping fixture and take out the bulb.
4. Replace with a new bulb and reinstall the head lamp assembly in the reverse order.

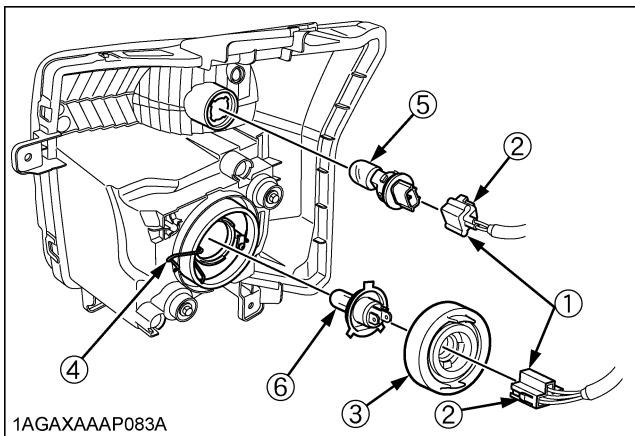

1AGAXAAP083A

- (1) Electrical connector
- (2) Lock buttons
- (3) Rubber boot
- (4) Clamping fixture
- (5) Bulb (Side work light)
- (6) Bulb (Head lamp)

IMPORTANT :

- Be sure to use a new bulb of the specified wattage.
- Never touch the bulb surface (glass) with bare hands. Fingerprints, for example, may break the bulb.

■ Replacing Radiator Hose (Water pipes)

Consult your local KUBOTA Dealer for this service.

■ Replacing Fuel Hose

Consult your local KUBOTA Dealer for this service.

■ Replacing Intake Air Line

Consult your local KUBOTA Dealer for this service.

■ Replacing Power Steering Hose

Consult your local KUBOTA Dealer for this service.

■ Replacing Oil Cooler Line [HST Type]

Consult your local KUBOTA Dealer for this service.

■ Replacing Oil Separator Hose

Consult your local KUBOTA Dealer for this service.

STORAGE



WARNING

To avoid personal injury or death:

- Do not clean the machine while the engine is running.
- To avoid the danger of exhaust fume poisoning, do not operate the engine in a closed building without proper ventilation.
- When storing, remove the key from the key switch to avoid unauthorized persons from operating the tractor and getting injured.

TRACTOR STORAGE

If you intend to store your tractor for an extended period of time, follow the procedures outlined below.

These procedures will insure that the tractor is ready to operate with minimum preparation when it is removed from storage.

1. Check the bolts and nuts for looseness, and tighten if necessary.
2. Apply grease to tractor areas where bare metal will rust also to pivot areas.
3. Detach the weights from the tractor body.
4. Inflate the tires to a pressure a little higher than usual.
5. Change the engine oil and run the engine to circulate oil throughout the engine block and internal moving parts for about 5 minutes.
6. Keep the clutch disengaged. If the clutch is left engaged for a long period of time, the clutch plate may rust, making clutch disengagement impossible at the next operation.

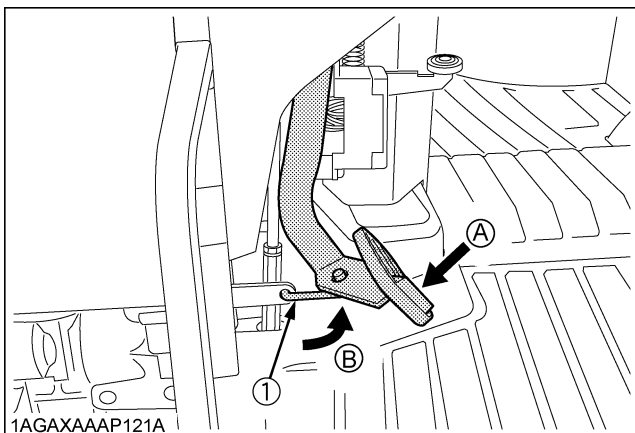

(1) Lock plate

(A) "DEPRESS"

(B) "HOOK TO LOCK"

7. With all implements lowered to the ground, coat any exposed hydraulic cylinder piston rods with grease.

8. Remove the battery from the tractor. Store the battery following the battery storage procedures. (See "Checking Battery Condition" in "EVERY 100 HOURS" in "PERIODIC SERVICE" section.)
9. Keep the tractor in a dry place where the tractor is sheltered from the elements. Cover the tractor.
10. Store the tractor indoors in a dry area that is protected from sunlight and excessive heat. If the tractor must be stored outdoors, cover it with a waterproof tarpaulin. Jack the tractor up and place blocks under the front and rear axles so that all 4 tires are off the ground. Keep the tires out of direct sunlight and extreme heat.

IMPORTANT :

- When washing the tractor, be sure to stop the engine. Allow sufficient time for the engine to cool before washing.
- Cover the tractor after the muffler and the engine have cooled down.

REMOVING THE TRACTOR FROM STORAGE

1. Check the tire air pressure and inflate the tires if they are low.
2. Jack the tractor up and remove the support blocks from under the front and rear axles.
3. Install the battery. Before installing the battery, be sure it is fully charged.
4. Check the fan belt tension.
5. Check all fluid levels (engine oil, transmission/hydraulic oil, engine coolant and any attached implements).
6. Start the engine. Observe all gauges. If all gauges are functioning properly and reading normal, move the tractor outside. Once outside, park the tractor and let the engine idle for at least 5 minutes. Shut the engine off and walk around tractor and make a visual inspection looking for evidence of oil or water leaks.
7. With the engine fully warmed up, release the parking brake and test the brakes for proper adjustment as you move forward. Adjust the brakes as necessary.

TROUBLESHOOTING

ENGINE TROUBLESHOOTING

If something is wrong with the engine, refer to the table below for the cause and its corrective measure.

Trouble		Cause	Countermeasure
Engine is difficult to start or won't start.		<ul style="list-style-type: none"> No fuel flow. 	<ul style="list-style-type: none"> Check the fuel tank and the fuel filter. Replace filter if necessary.
		<ul style="list-style-type: none"> Air or water is in the fuel system. 	<ul style="list-style-type: none"> Check to see if the fuel line coupler bolt and nut are tight. Bleed the fuel system (See "Bleeding Fuel System" in "SERVICE AS REQUIRED" in "PERIODIC SERVICE" section.)
		<ul style="list-style-type: none"> In winter, oil viscosity increases, and engine revolution is slow. 	<ul style="list-style-type: none"> Use oils of different viscosities, depending on ambient temperatures. Use engine block heater. (Option)
		<ul style="list-style-type: none"> Battery becomes weak and the engine does not turn over quick enough. 	<ul style="list-style-type: none"> Clean battery cables & terminals. Charge the battery. In cold weather, always remove the battery from the engine, charge and store it indoors. Install it on the tractor only when the tractor is going to be used.
Insufficient engine power.		<ul style="list-style-type: none"> Insufficient or dirty fuel. The air cleaner is clogged. 	<ul style="list-style-type: none"> Check the fuel system. Clean or replace the element.
Engine stops suddenly.		<ul style="list-style-type: none"> Insufficient fuel. 	<ul style="list-style-type: none"> Refuel. Bleed the fuel system if necessary.
Exhaust fumes are colored.	Black	<ul style="list-style-type: none"> Fuel quality is poor. Too much oil. The air cleaner is clogged. 	<ul style="list-style-type: none"> Change the fuel and fuel filter. Check the proper amount of oil. Clean or replace the element.
	Blue white	<ul style="list-style-type: none"> The inside of exhaust muffler is damp with fuel. Injection nozzle trouble. Fuel quality is poor. 	<ul style="list-style-type: none"> Heat the muffler by applying load to the engine. Check the injection nozzle. Change the fuel and fuel filter.
Engine overheats		<ul style="list-style-type: none"> Engine overloaded 	<ul style="list-style-type: none"> Shift to lower gear or reduce load.
		<ul style="list-style-type: none"> Low coolant level 	<ul style="list-style-type: none"> Fill cooling system to the correct level; check radiator and hoses for loose connections or leaks.
		<ul style="list-style-type: none"> Loose or defective fan belt 	<ul style="list-style-type: none"> Adjust or replace fan belt.
		<ul style="list-style-type: none"> Dirty radiator core or grille screens 	<ul style="list-style-type: none"> Remove all trash.
		<ul style="list-style-type: none"> Coolant flow route corroded 	<ul style="list-style-type: none"> Flush cooling system.

If you have any questions, consult your local KUBOTA Dealer.

HST (Hydrostatic Transmission) TROUBLESHOOTING

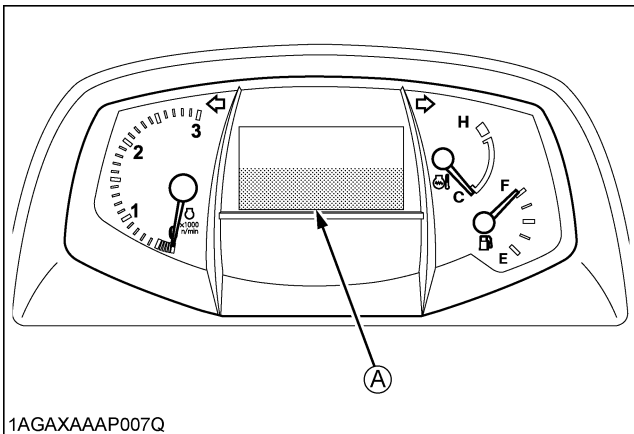

1AGAXAAP007Q

(A) Error message is displayed at here

Display on IntelliPanel(TM)	Trouble Item (Affected Model)	Operator's action
ERROR No. 20 CAN NG	Communication error between ECU and IntelliPanel(TM)	Contact your local KUBOTA Dealer.
ERROR No. 30 ECU Memory DEVICE NG	ECU's memory device is in trouble	
ERROR No. 40 Input Voltage NG	Input voltage of lever sensor from ECU is in trouble	
ERROR No. 80 Range Shift SENSOR NG	Sensor for range gear shift lever is in trouble	Contact your local KUBOTA Dealer. The speed range (H, M and L) is not displayed in the LCD screen. The range gear shift lever still works to select the H, M and L speeds. In selecting M or L, however, the feeling is somewhat different at a start, stop and other actions.
ERROR No. 81 HST Pedal SENSOR NG	Sensor for speed control pedal is in trouble	Contact your local KUBOTA Dealer. The speed control pedal cannot be used to run the tractor.
ERROR No. 82 Swash Plate SENSOR NG	Sensor for swash plate of HST is in trouble	Contact your local KUBOTA Dealer. The tractor can travel both forward and backward, but with a drop in maximum speed.
ERROR No. 83 Cruise SWITCH NG	Sensor for cruise control switch is in trouble	Contact your local KUBOTA Dealer. The cruise control does not work. The speed control pedal alone serves to run the tractor.
ERROR No. 84 Throttle SENSOR NG	Sensor for engine throttle is in trouble	Contact your local KUBOTA Dealer. With the STALL GUARD or AUTO H-DS/STALL GUARD mode being selected, the tractor automatically gets in the MANUAL mode.
ERROR No. 87 Engine Speed SENSOR NG	Sensor for engine revolution is in trouble	
ERROR No. 90 HST-F SOLENOID NG	Proportional valve for forward is in trouble	Contact your local KUBOTA Dealer. The tractor cannot travel forward (backward only).
ERROR No. 91 HST-R SOLENOID NG	Proportional valve for reverse is in trouble	Contact your local KUBOTA Dealer. The tractor cannot travel backward (forward only).

Display on IntelliPanel(TM)	Trouble Item (Affected Model)	Operator's action
ERROR No. 92 Hi-Lo SOLENOID NG	Motor for Hi-Lo shift is in trouble	Contact your local KUBOTA Dealer. Using the H-DS lever, the Lo speed alone can be selected (Hi speed not selectable). In the HST mode, only the STALL GUARD and MANUAL modes can be selected.
ERROR No. 93 Starter RELAY NG	Relay for engine starter motor is in trouble	Contact your local KUBOTA Dealer. The engine cannot start.
ERROR No. 94 OPC NG	Relay for engine shut off is in trouble	Contact your local KUBOTA Dealer. The Operator Presence Control (OPC) system gets activated, and the engine stops itself.
ERROR No. 95 PTO SOLENOID NG	Solenoid (PTO) is in trouble	Contact your local KUBOTA Dealer. The PTO shaft cannot rotate.

GST (Glide Shift Transmission) TROUBLESHOOTING

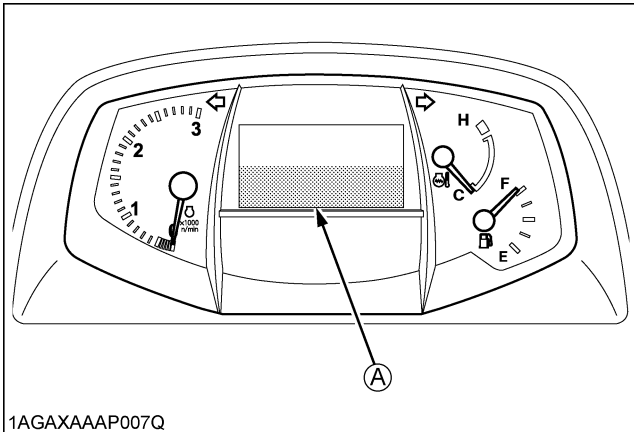

1AGAXAAP007Q

(A) Error message is displayed at here

Display on IntelliPanel(TM)	Trouble Item (Affected Model)	Operator's action
ERROR No. 20 CAN NG	Communication error between ECU and IntelliPanel(TM)	Contact your local KUBOTA Dealer.
ERROR No. 30 ECU Memory DEVICE NG	ECU's memory device is in trouble	
ERROR No. 40 Input Voltage NG	Input voltage of lever sensor from ECU is in trouble	
ERROR No. 50 GST Lever SENSOR NG	GST lever sensor is in trouble	
ERROR No. 51 Shuttle SWITCH NG	Shuttle lever sensor is in trouble	
ERROR No. 60 GST SOLENOID NG	Proportional valve is in trouble	
ERROR No. 61 1, 7, 8th Speed NG	Solenoid 1 is in trouble (At forward or neutral)	If the shift solenoid gets in trouble, the gearshift lever remains at the same position but the real speed is automatically changed to an operable speed range or neutral. Such a self-changed speed range will be displayed on the panel. Take note of what is displayed and then contact your dealer.
ERROR No. 61 1, 5th Speed NG	Solenoid 1 is in trouble (At reverse)	
ERROR No. 61 1st Speed NG	Solenoid 1 is in trouble	
ERROR No. 62 2, 9, 10th Speed NG	Solenoid 2 is in trouble (At forward or neutral)	If the shift solenoid gets in trouble, the gearshift lever remains at the same position but the real speed is automatically changed to an operable speed range or neutral. Such a self-changed speed range will be displayed on the panel. Take note of what is displayed and then contact your dealer.
ERROR No. 62 2, 6th Speed NG	Solenoid 2 is in trouble (At reverse)	
ERROR No. 62 2nd Speed NG	Solenoid 2 is in trouble	
ERROR No. 63 3, 4, 11th Speed NG	Solenoid 3 is in trouble (At forward or neutral)	If the shift solenoid gets in trouble, the gearshift lever remains at the same position but the real speed is automatically changed to an operable speed range or neutral. Such a self-changed speed range will be displayed on the panel. Take note of what is displayed and then contact your dealer.
ERROR No. 63 3, 7th Speed NG	Solenoid 3 is in trouble (At reverse)	
ERROR No. 63 3rd Speed NG	Solenoid 3 is in trouble	

Display on IntelliPanel(TM)	Trouble Item (Affected Model)	Operator's action
ERROR No. 64 5, 6, 12th Speed NG	Solenoid 4 is in trouble (At forward or neutral)	If the shift solenoid gets in trouble, the gearshift lever remains at the same position but the real speed is automatically changed to an operable speed range or neutral. Such a self-changed speed range will be displayed on the panel. Take note of what is displayed and then contact your dealer.
ERROR No. 64 4, 8th Speed NG	Solenoid 4 is in trouble (At reverse)	
ERROR No. 64 4th Speed NG	Solenoid 4 is in trouble	
ERROR No. 65 1-6th Speed NG	Solenoid 5 (Hi-Lo) is in trouble (At forward or neutral)	If the shift solenoid gets in trouble, the gearshift lever remains at the same position but the real speed is automatically changed to an operable speed range or neutral. Such a self-changed speed range will be displayed on the panel. Take note of what is displayed and then contact your dealer.
ERROR No. 65 1-4th Speed NG	Solenoid 5 (Hi-Lo) is in trouble (At reverse)	
ERROR No. 66 3, 5, 7, 9th Speed NG	Solenoid 6 (H-L) is in trouble	If the shift solenoid gets in trouble, the gearshift lever remains at the same position but the real speed is automatically changed to an operable speed range or neutral. Such a self-changed speed range will be displayed on the panel. Take note of what is displayed and then contact your dealer.
ERROR No. 67 5-8th Speed NG	Solenoid (OD) is in trouble	
ERROR No. 93 Starter RELAY NG	Relay for engine starter motor is in trouble	Contact your local KUBOTA Dealer. The engine cannot start.
ERROR No. 94 OPC NG	Relay for engine shut off is in trouble	Contact your local KUBOTA Dealer. The Operator Presence Control (OPC) system gets activated, and the engine stops itself.
ERROR No. 95 PTO SOLENOID NG	Solenoid (PTO) is in trouble	Contact your local KUBOTA Dealer. The PTO shaft cannot rotate.

MT(Manual Transmission) TROUBLESHOOTING

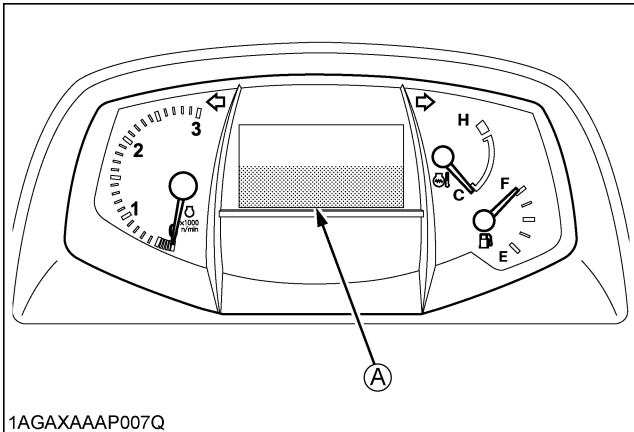

1AGAXAAP007Q

(A) Error message is displayed at here

Display on IntelliPanel(TM)	Trouble Item (Affected Model)	Operator's action
ERROR No. 20 CAN NG	Communication error between ECU and IntelliPanel(TM)	Contact your local KUBOTA Dealer.
ERROR No. 30 ECU Memory DEVICE NG	ECU's memory device is in trouble	
ERROR No. 40 Input Voltage NG	Input voltage of lever sensor from ECU is in trouble	
ERROR No. 51 Shuttle SWITCH NG	Shuttle lever sensor is in trouble	
ERROR No. 93 Starter RELAY NG	Relay for engine starter motor is in trouble	Contact your local KUBOTA Dealer. The engine cannot start.
ERROR No. 94 OPC NG	Relay for engine shut off is in trouble	Contact your local KUBOTA Dealer. The Operator Presence Control (OPC) system gets activated, and the engine stops itself.
ERROR No. 95 PTO SOLENOID NG	Solenoid (PTO) is in trouble	Contact your local KUBOTA Dealer. The PTO shaft cannot rotate.

OPTIONS

Consult your local KUBOTA Dealer for further details.

- Engine Block Heater
For extremely cold weather starting
- Front end weights
For front ballast
- Rear Wheel Weights
For rear ballast
- Creep gear
- Double Acting Remote Hydraulic Control Valve
- Draft Control
- Top & tilt kit (For scraper)
- Swinging Drawbar
- Clevis for Drawbar
- Work Light
High visibility for night work

APPENDICES

INDEX

3-point Hitch Lowering Speed	76	EGR Cooler	108
Adjustment of Foldable ROPS	37	EGR Pipe.....	112
Air Cleaner Primary Element.....	99	EGR System.....	109
Air Cleaner Primary Element and Secondary Element.....	107	Electrical Outlet	66
Anti-Freeze.....	109	Engine Oil	103
Antifrost Heater for Oil Separator	112	Engine Oil Filter	104
Antifrost Heater for Oil Separator (if equipped)	32	Engine Oil Level	93
ATA (Auto Throttle Advance) Switch.....	51	Engine Start System.....	97
Battery Condition.....	101	Engine Valve Clearance	107
Block Heater (if equipped).....	32	Exhaust Manifold	107
Boost Sensor Hose	112	Fan Belt Tension	99
Brake Pedal.....	96	Float Control	76
Brake Pedal.....	100	Floor Sheet	91
Brake Pedals (Right and Left)	41	Foot Throttle	55
Brake Pedals and Clutch Pedal.....	96	Foot Throttle	58
Category 1	72	Front Axle Case Oil	106
Category 1 & 2	72	Front Axle Pivot	107
Checking and Refueling	92	Front Ballast	84
Clutch Housing Water	113	Front Wheel Drive Lever.....	48
Clutch Pedal.....	42	Front Wheel Drive Lever.....	54
Clutch Pedal.....	100	Front Wheel Drive Lever.....	57
Control Lever and Hydraulic Hose Connections	76	Front Wheels (with 4-wheel drive)	81
Coolant Level	93	Fuel Filter.....	106
Coolant Temperature Gauge.....	64	Fuel Gauge.....	63
Cooling System and Coolant.....	108	Fuel Hose	112
Creep Gear Shift Lever (if equipped)	54	Fuel Hose	116
Creep Gear Shift Lever (if equipped)	57	Fuel Injector Nozzle Tip.....	107
Cruise Control	50	Fuel Line.....	110
Diesel Particulate Filter (DPF) Muffler.....	20	Fuel System.....	113
Differential Lock.....	65	Fuse.....	114
Display Mode.....	59	Gauges, Meter and Easy Checker(TM).....	96
Do not Operate the Tractor at Full Speed for the First 50 Hours.....	35	Glove Box.....	38
DPF Differential Pressure Sensor Hose.....	112	Grill, Radiator Screen and Oil Cooler	94
DPF Differential Pressure Sensor Pipe	112	GST type	10
DPF Muffler	95	Hand Throttle Lever.....	49
DPF Muffler	110	Hand Throttle Lever.....	55
DPF Regeneration Process.....	21	Hand Throttle Lever.....	58
Draft Control (if equipped).....	75	Handling Points	21
Drawbar	72	H-DS (Hydro Dual Speed) Lever	44
Drawbar Length.....	74	Head Lamp	116
Dual Tires	81	Head Light, Turn Signal / Hazard Light etc....	96
Dust Indicator	94	Hood	91
Easy Checker(TM)	63	Horn Button (if equipped)	39
		HST Mode	45
		HST Response Control.....	43
		HST Type	9
		Hydraulic Control Unit Use Reference Chart.	80
		Immediately Stop the Engine if:	62

Inflation Pressure	81	Rear Wheels	83
Intake Air Line	110	Regeneration Operating Procedure	22
Intake Air Line	112	Regeneration Operating Procedure	24
Intake Air Line	116	Remote Control Valve	78
IntelliPanel (TM) Message	69	Remote Control Valve Coupler	
IntelliPanel(TM) Message	62	Connecting and Disconnecting	79
Lift Cylinder Hose	112	Remote Control Valve Lever	78
Lift Cylinder Hose	113	Resetting the Trip Meter and	
Lifting Rod (Right)	73	Setting the Clock	60
Light Bulb	115	Seat Belt	38
Light Switch	39	Seat Belt and ROPS	96
Liquid Ballast in Rear Tires	85	SERVICE INSPECT mode	
Loader / Remote Control Valve Lever	77	displaying/resetting procedure	61
Lubricating Grease Fittings	96	Shuttle Shift Lever	52
Lubricating Oil for New Tractors	35	Side Cover	91
Main Gear Shift Lever	53	Side Work Light Switch	40
Main Gear Shift Lever	56	Slow-Blow Fuses	115
Manual Transmission Type	11	Speed Control Pedal	49
Mid-PTO (if equipped)	68	Stationary PTO	69
Mixed Control	76	Stopping	58
Movable Parts	96	Supply Pump	109
Oil Cooler Line [HST Type]	112	Swing Drawbar	74
Oil Cooler Line [HST Type]	113	Synchro-Shuttle Shift Lever	56
Oil Cooler Line [HST Type]	116	Tachometer	64
Oil Separator Element	108	Telescopic Lower Links	73
Oil Separator Hose	112	Telescopic Stabilizers	73
Oil Separator Hose	113	Throttle-Up Switch	47
Oil Separator Hose	116	Tilt Steering Adjustment	38
Operating on Slopes and Rough Terrain	66	Tips on Diesel Particulate Filter (DPF)	
Operating the Tractor on a Road	65	Regeneration	27
Operator Presence Control	98	To Fold the ROPS	35
Operator's Seat	37	To Raise the ROPS to Upright Position	36
Parking	64	Toe-in	103
Parking Brake	49	Top Link	73
Parking Brake	55	Top link mounting holes	72
Parking Brake	58	Tractor Lights	40
PCV (Positive Crankcase Ventilation) Valve	108	Transmission Fluid / Hydraulic Oil Filter	104
PM Warning Level and Required Procedures	23	Transmission Fluid Level	93
PM Warning Level and Required Procedures	25	Transmission Oil Filter [HST Type]	102
Position Control	75	Transport the Tractor Safely	66
Power Steering	66	Turbocharger	109
Power Steering Hose	113	Turn Signal / Hazard Light Switch	39
Power Steering Hose	116	Valve Lock	78
Power Steering Line	111	Walk Around Inspection	92
PTO Clutch Control Switch	67	Warm-Up Transmission Oil	
PTO Shaft Cover and Shaft Cap	70	in the Low Temperature Range	33
Radiator Hose (Water pipes)	112	Water Separator	92
Radiator Hose (Water pipes)	116	Water Separator	107
Radiator Hose and Clamp	111	Wheel Bolt Torque	99
Range Gear Shift Lever (Hi-Lo)	56		
Range Gear Shift Lever (L-M-H)	48		
Rear Ballast	85		