

Specifications

Model		SVL65-2		
Type of operator station		Open CAB / Closed CAB		
Engine	Model	V2607-CR-TE4		
	Output (SAE J1995 gross)	HP (kW)/rpm	68.4 (51.0) / 2600	
	Output (SAE J1349 net)	HP (kW)/rpm	62.5 (46.6) / 2600 / 59.9 (44.7) / 2600	
	Displacement	cu.in. (cc)	159.6 (2615)	
	Cylinders		4	
	Bore x Stroke	in. (mm)	3.4 (87) x 4.3 (110)	
	Aspiration		Turbocharged	
Loader Performance	Rated operating capacity-35% tipping load	lbs. (kg)	2100 (953)	
	Rated operating capacity-50% tipping load	lbs. (kg)	3000 (1361)	
	Tipping load	lbs. (kg)	6000 (2722)	
	Breakout force	Bucket	lbf. (kg)	4614 (2093)
		Lift arm	lbf. (kg)	4266 (1935)
	Lift arm path		Vertical	
Undercarriage	Track Width	Standard	in. (mm)	12.6 (320)
		Wide	in. (mm)	15.0 (380)
	Ground pressure	Standard	psi	5.0
		Wide	psi	4.4
	Track rollers (per side)		4	
	Track ground contact length	in. (mm)	57.9 (1470)	
	Travel speed	Low	mph (km/h)	4.9 (7.8)
		High	mph (km/h)	7.1 (11.5)
Traction force	lbf. (kgf)	8406 (3813)		
Min. ground clearance	in. (mm)	9.2 (233)		
Hydraulic system	Aux. hydraulic flow	Std./High Flow gpm (ℓ/min.)	17.4 (65.8) / 27.0 (102.2)	
	Aux. hydraulic pressure	psi (kgf/cm ²)	3263 (229.4)	
Service refill capacities	Hydraulic system	gal. (ℓ)	13.2 (50)	
	Hydraulic tank	gal. (ℓ)	5.4 (20.3)	
	Fuel tank	gal. (ℓ)	21.7 (82)	
Operating weight (Includes operator weight 165lbs.)	lbs. (kg)	8135 (3690) / 8631 (3915)		

Dimensions

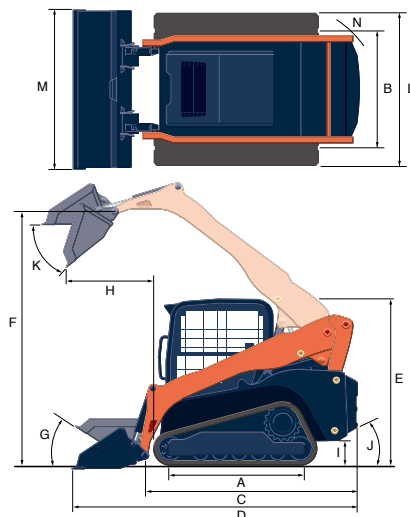

Model		SVL65-2	
A	Length of track on ground	in. (mm)	57.9 (1470)
B	Track gauge	in. (mm)	52.6 (1337)
C	Length w/o bucket	in. (mm)	107.3 (2725)
D	Length w/bucket on ground	in. (mm)	136.4 (3465)
E	Height to top of cab	in. (mm)	79.9 (2029)
F	Bucket hinge pin height at max. lift	in. (mm)	118.5 (3010)
G	Rollback angle at carry position	degree	30
H	Reach at max. lift and dump	in. (mm)	34.9 (886)
I	Ground clearance	in. (mm)	9.2 (233)
J	Departure angle	degree	30
K	Max. dump angle	degree	40
L	Vehicle width Standard track / Wide track	in. (mm)	65.2 (1657) / 67.6 (1717)
M	Width with bucket	in. (mm)	68 (1727) / 74 (1880)
N	Turning radius from center-machine rear	in. (mm)	57.1 (1451)

Kubota Canada Ltd. reserves the right to change the stated specifications without notice. This brochure is for descriptive purposes only and reasonable efforts were used to set forth the contained information; some items shown may be optional and some products shown may not be available at all dealerships. Kubota disclaims all representations and warranties, express or implied, or any liability from the use of this brochure. For complete warranty, safety and product information, consult your local Kubota dealer and the operator's manual. Power (HP/KW) and other specifications are based on various standards or recommended practices. For your safety, Kubota strongly recommends the use of a Rollover Protective Structure (ROPS) and seat belt in almost all applications. This brochure is intended for Canada only. For information regarding Kubota products or services outside these areas, see Kubota Corporation's global web site. Kubota does not provide parts, warranty or service for any Product which is re-sold or retailed in any country other than the country for which the Product(s) were designed or manufactured.



KUBOTA CANADA LTD.

Head Office:
5900 14th Avenue, Markham, Ontario L3S 4K4
TEL: (905) 294-7477

Visit our web site at: www.kubota.ca

©2019 Kubota Corporation



**Kubota
Genuine Parts**
for maximum
performance,
durability and
safety



For Earth, For Life
Kubota

SVL

KUBOTA COMPACT TRACK LOADER SVL65-2

Kubota's powerful and productive Compact Track Loader for those big jobs in small places.





Tight workspaces are no challenge for a loader packed with big features.

Here's the Compact Track Loader you've been waiting for. A smaller loader that will take you places... easy to transport and works in tight places with "big" operator comfort and power performance. Make sure to try the SVL65-2 on for size today.

- SUPERIOR OPERABILITY
- COMPACT AND LIGHT WEIGHT
- EXCEPTIONAL OPERATOR COMFORT

COMPACT TRACK LOADER

SVL65-2

Engine gross horsepower (SAE J 1995): 68.4 HP (51.0 kW)
Rated operating capacity (35% of tipping load): 2100 lbs (953 kg)
Rated operating capacity (50% of tipping load): 3000 lbs (1361 kg)
Bucket breakout force: 4614 lbs (2093 kg)
Operating weight (open cab, including operator weight 165 lbs): 8135 lbs (3690 kg)





Kubota Engine

- Powerful Kubota Engine**
 A reliable 68 HP* Kubota engine brings plenty of power to any excavating or loading job, letting you work faster and with greater efficiency. * Engine HP Gross (SAE J1995)
- Common Rail System and Diesel Particulate Filter (DPF) Muffler**
 The Common Rail System (CRS) electronically controls the fuel injection timing and amount in stages rather than all at once for optimal combustion; resulting in greater efficiency, better fuel economy and less engine noise. The combination of Exhaust Gas Re-circulation (EGR) and Diesel Particulate Filter (DPF) reduces the emissions making the SVL Series engine Tier IV certified.
- Automatic Regeneration System**
 Kubota's original automatic regeneration system automatically burns accumulated particulate matter (soot) in the DPF muffler to keep the muffler clean for longer operation. For operational and safety reasons, automatic regeneration can be turned off with the inhibit switch when operating in areas near combustible materials.



Travel Performance

- Standard Two-speed Travel**
 Shift from low gear at 4.9 mph to high gear at 7.1 mph to get the job done faster.
- Higher Ground Clearance**
 A high ground clearance of 9.2 inches lets you travel over large obstacles with ease.
- Low Ground Contact Pressure**
 With a ground pressure of just 5.0/4.4 psi with STD / WIDE tracks, the SVL65-2 minimizes crawler marks on the turf or ground.

OUTSTANDING PERFORMANCE

Excellent Workability

- Outstanding Kubota Vertical Lift**
 Easily dump into the tallest dumpster or truck, thanks to Kubota's outstanding vertical lift. It raises the bucket even higher (118.5 in. at the hinge pin) without sacrificing any of the SVL65-2's exceptionally long reach (34.9 in.).
- Standard Self-leveling Function**
 The standard self-leveling during lifting feature, keeps the bucket or forks level without the need to manually adjust the angle. This function may be simply turned on and off with the flip of a switch.



- Strong Bucket and Arm Breakout Force**
 With a bucket breakout force of 4266 lbf at the arm and 4614 lbf at the bucket, the SVL65-2 lets you handle even the toughest jobs with speed and efficiency.

- Electronic Travel Torque Management**
 Electronic Travel Torque Management System lets you work faster with more power. The ECU constantly monitors the load of the machine to optimally control hydraulic pump output according to the load, preventing engine stalls for smoother operation even under severe conditions.

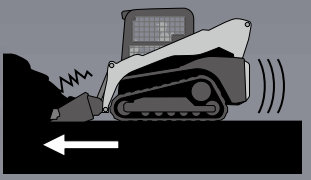

EXCEPTIONAL COMFORT

● Sliding Front Door

The sliding front door can be opened regardless of the position of the bucket or loader arms. Full machine operation is possible with the door open if desired.

● Wider Cab Entrance

A wide entrance makes it easier to get in and out.

● Ample Legroom

A comfortable operator is a productive operator. That's why the SVL65-2's cab provides ample room for the operator's legs. The floor mat can be removed for cleaning, and a small opening in the floor allows easy removal of dirt and debris.



● 360° Visibility

The edge of the bucket can be seen from the seat. Improved visibility translates to better safety on the job.



● Roomy and Clean Cab

With a large and comfortable operator's station, the SVL65-2 offers an extra level of comfort and convenience.

● Armrest

The spacious cab also includes ergonomically placed arm rests on the right and left sides of the seat to minimize operator fatigue. The arm rests have been designed to increase operator space.

Functional Equipment Layout

1. User Friendly Meter Panel

The SVL65-2's user-friendly meter panel is particularly easy to use. With just a glance at the panel and without leaving the seat, the operator can quickly get a full picture of the machine's operating status.

2. Dial and Foot Throttle

The SVL65-2 offers two ways to control the engine speed: dial and foot throttle. The dial lets the operator set the speed when a steady engine speed is required for a particular job, while the foot throttle lets the operator continuously vary the engine speed.

3. Intuitive Switch Placement

The most frequently used switches and buttons are placed within easy reach on the operator's right-hand side, letting the operator quickly access those controls.



A/C Performance

● Optimized Air Conditioning

The climate control system provides an optimized airflow for outstanding cooling and heating performance—and supreme operator comfort all year round.

● Enhanced Defrosting and Demisting Functions

Ample airflow prevents the windows from fogging up or freezing in colder climates.



EASY MAINTENANCE

● Simple Access

The SVL65-2's rear door opens wide and the cab tilts up to provide fast and easy access to the rear of the engine and other parts for maintenance and repairs, reducing downtime to a minimum.

● Slide and Tilt Radiator and Oil Cooler

Both the radiator and the oil cooler quickly slide forward and tilt downwards, ensuring easy access to other engine parts during maintenance.

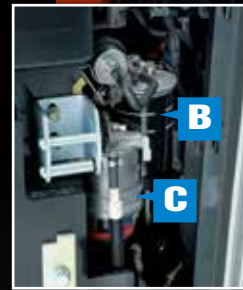

- A. Dual Element Air Cleaner**
- B. Fuel Filter**
- C. Water Separator**
- D. Battery**
- E. Coolant**
- F. Radiator**

● Tilt-up Cabin

The cab can be tilted 72° without having to lift the arm, allowing easy access to the hydraulic pumps, valves, lines and hydraulic tank.

● Air-filter Warning Indicator

An air-filter warning indicator prevents damage to the engine from dust by instantly informing the operator when the air filter becomes clogged.

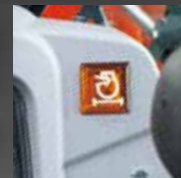

● Bolt on Handrails

The handrails are bolted to the cab to allow for quick and easy replacement in the event they get damaged.

● Easy Clean Out of Tracks

The SVL65-2's track frame is designed for less material retention and easy clean out.



Impressive Durability

1. Welded Mainframe and Undercarriage

The SVL65-2 features a one-piece mainframe and undercarriage that is not only rugged and simple, but ensures excellent durability even under extreme working conditions. Triple-flanged track rollers reduce the risk of detracking as well as provide a smoother ride for the operator.

● Side Window Grill

Both operator and windows are protected by grills attached to the outside of the cab.

2. Well Protected Cylinders and Hoses

The cylinders and hoses are extremely well protected to reduce the risk of costly repairs and downtime.

3. Durable Rear Door and Protective Bumper

A durable rear door and solid metal bumper protect the rear of the machine from damage.

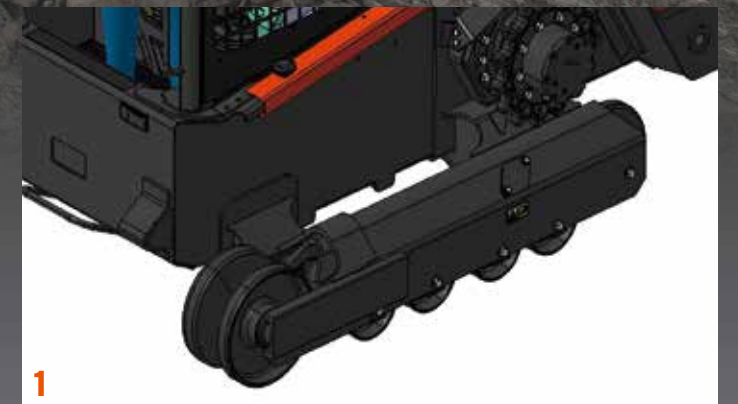

EXCELLENT VERSATILITY

● High-flow Hydraulics (Option)

Get up to 27.0 gpm AUX flow rate for greater attachment work efficiency.

● 14-pin Connector

The 14-pin electrical coupler, and multifunction control grip switches allow for a multitude of electrical functions to operate most attachments. 14-pin coupler comes standard with high-flow hydraulics.



● Hydraulic Quick Coupler (Option)

Ideal when frequently changing attachments, the SVL65-2's optional quick coupler lets you quickly get back to work.



● Multi-function Levers

The multi-function levers provide fingertip control of all major vehicle and attachment operations, letting you keep both hands on the levers at all times for optimal operating efficiency. Standard on High-flow models, these levers can also be installed as a kit on Standard flow models.

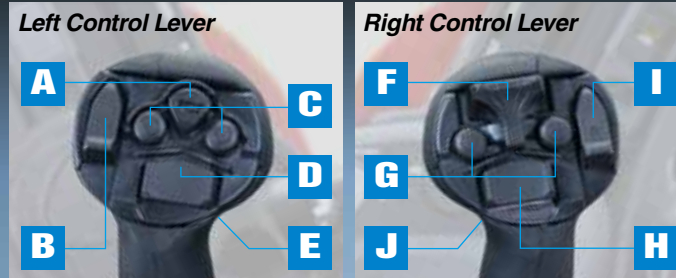

- Left Control Lever**
- A. Horn
 - B. -Not used-
 - C. AUX1
 - D. AUX3 or Turn Signal
 - E. Travel Speed

- Right Control Lever**
- F. Proportional AUX Switch
 - G. AUX Hold Switch
 - H. AUX2
 - I. AUX Mode Change
 - J. Float Switch



ATTACHMENT

The SVL65-2 Compact Track Loader can connect to a variety of attachments, letting you take on loading, excavating, augering, grappling, and a wide range of other tasks.

**Not all attachments are OEM-KUBOTA.*

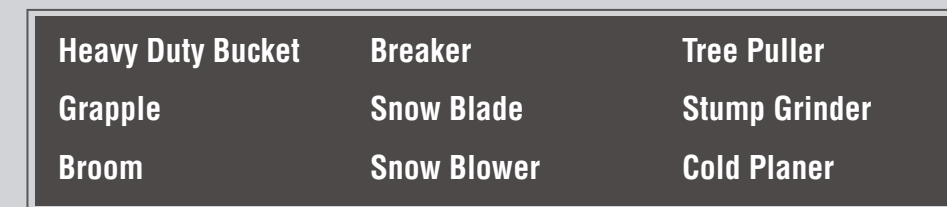

EQUIPMENT

STANDARD EQUIPMENT

- Open CAB
- Top / Rear window
- 2" Retractable seat belt
- Operator presence control
- Pull down arm rest
- Dial and Foot throttle
- 12V electric outlet
- Horn
- Lockable fuel cap
- Backup alarm
- Work lights (Front 2 / Rear 2)
- Glow plug
- Mechanical quick coupler
- Loader arm float function
- Bucket self-leveling (up only)
- Wet disc parking brake
- Two-speed travel
- Rubber crawler (320mm)
- Air filter warning indicator

OPTIONAL EQUIPMENT

- Closed CAB (w/ air conditioning)*
- High-flow hydraulics* (1/2" and 3/4" couplers)*
- 14-pin coupler (standard on high flow model)
- Hydraulic quick coupler*
- Rubber crawler (380mm)*
- Polycarbonate door
- Radio Ready (cab)
- 3" Retractable seat belt
- Rear bonnet lock Kit
- Rear view mirror
- Strobe light
- Beacon light
- Engine block heater
- Radiator screen
- ...and much more.

*Factory Option