

SPECIFICATIONS

Model		KX080-4S2		KX080-4S2 Angle Blade	
Type of cabin		ROPS / OPG (TOP Guard, Level I)			
Type of tracks		Rubber / Steel			
Engine	Model		Kubota V3307-CR-TE5		
	Output (SAE J1995 gross)	HP (kW)/rpm	66.6 (49.7) / 2000		
	Output (SAE J1349 net)	HP (kW)/rpm	62.3 (46.5) / 2000		
	Displacement	cu. in. (cc)	203.3 (3331)		
Dimensions	Overall length	ft. in. (mm)	21'11.9" (6450)		
	Overall height	ft. in. (mm)	8'4" (2540)		
	Overall width	ft. in. (mm)	7'2.6" (2200)		
	Min. ground clearance	in. (mm)	14.0 (355)		
Hydraulic system	Pump capacity	GPM (ℓ/min)	22.3 (84.6) Variable × 2		
	Auxiliary hydraulic flow	GPM (ℓ/min)	26.4 (100) / 14.7 (55.8)		
	Max. breakout force	Bucket / Arm	lbf. (kgf)	14660 (6650) / 8565 (3885)	
Drive system	Travel speed	Low / High	mph (km/h)	1.7 (2.7) / 3.0 (4.8)	
	Max. traction force	Low speed	lbf. (kgf)	15062 (6832)	
	Tumbler distance		ft. in. (mm)	7'6.6" (2300)	
	Crawler length		ft. in. (mm)	9'6.2" (2900)	
	Shoe width	Rubber / Steel	in. (mm)	17.7" (450) / 17.7" (450) (opt. 24" (610))	
	Ground contact pressure	Rubber / Steel	psi (kgf/cm ²)	5.3 (0.373) / 5.4 (0.380)	5.6 (0.394) / 5.7 (0.401)
Swing system	Unit swing speed		rpm	9.8	
	Boom swing angle	Left / Right	degree	67 / 60	
Blade	Dimensions	Width	ft. in. (mm)	7'2.6" (2200)	
		Height	ft. in. (mm)	19.7" (500)	20.1" (510)
	Max. lift above ground		in. (mm)	19.7" (500)	
	Max. drop below ground		in. (mm)	19.7" (500)	
Angle		degree	— / 25		
Hydraulic oil (reservoir / system)			gal (ℓ)	19.8 (75) / 38.6 (146)	
Fuel reservoir			gal (ℓ)	30.4 (115)	
Operating weight (Including operator's weight @ 165 lbs.)		Rubber / Steel	lbs. (kg)	18596 (8435) / 18706 (8485)	19456 (8825) / 19566 (8875)

DIMENSIONS

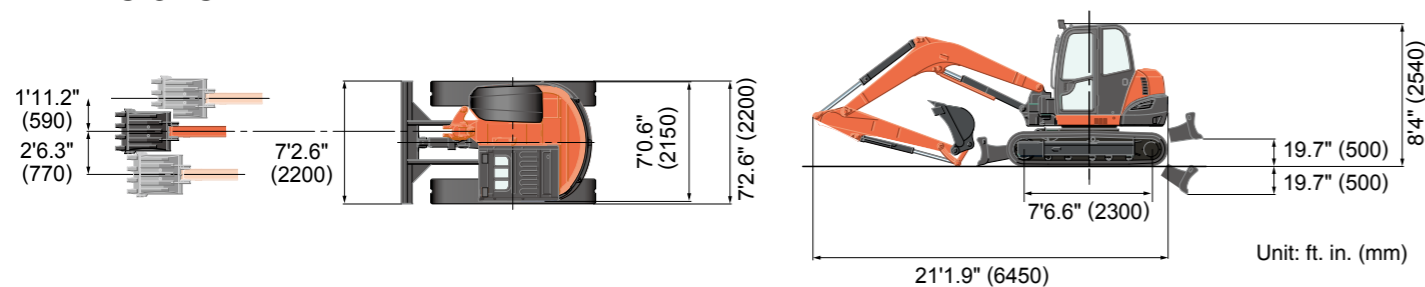

Kubota Canada Ltd. reserves the right to change the stated specifications without notice. This brochure is for descriptive purposes only and reasonable efforts were used to set forth the contained information; some items shown may be optional and some products shown may not be available at all dealerships. Kubota disclaims all representations and warranties, express or implied, or any liability from the use of this brochure. For complete warranty, safety and product information, consult your local Kubota dealer and the operator's manual. Power (HP/KW) and other specifications are based on various standards or recommended practices. For your safety, Kubota strongly recommends the use of a Rollover Protective Structure (ROPS) and seat belt in almost all applications. This brochure is intended for Canada only. For information regarding Kubota products or services outside these areas, see Kubota Corporation's global web site. Kubota does not provide parts, warranty or service for any Product which is re-sold or retailed in any country other than the country for which the Product(s) were designed or manufactured.

Kubota

KUBOTA CANADA LTD.

Head Office:
1155 Kubota Drive, Pickering, Ontario L1X 0H4
TEL: (905) 294-7477

Visit our web site at: www.kubota.ca

©2019 Kubota Corporation



For Earth, For Life
Kubota

KX

KUBOTA POWER UTILITY EXCAVATOR KX080-4 SUPER SERIES 2

Powerful and easy to operate, the KX080-4S2 is also environmentally friendly, making it the number one choice for all your power utility excavation jobs.



AB

FLOAT ANGLE BLADE

**Brute strength with a gentle touch.
Kubota's flagship power utility excavator brings power
and clean performance to a wide range of jobs.**

CLEAN AND POWERFUL EXCAVATOR

Performance that is powerful yet clean, a design that is bold yet practical. It starts with a rugged and reliable direct-injection Kubota engine with CRS and a DPF muffler. The KX080-4S2 offers even more improvements that enhance convenience and boost productivity and performance for a wide range of jobs.



Common Rail System and Diesel Particulate Filter (DPF) Muffler

The Common Rail System (CRS) electronically controls the fuel injection timing and amount in stages rather than all at once for optimal combustion. The results are great efficiency, better fuel economy and less engine noise. Its combination with the Exhaust Gas Recirculation (EGR) and Diesel Particulate Filter (DPF) Muffler reduces emissions to make the KX080-4S2 engine Tier IV certified.

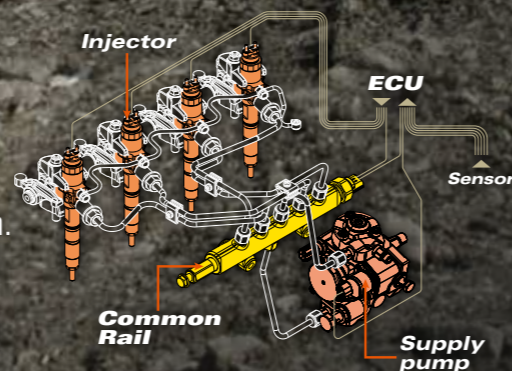

Automatic regeneration system

Kubota's original automatic regeneration system automatically burns accumulated particulate matter (soot) in the DPF muffler to keep the muffler clean for longer operation. With an improved regeneration system, the KX080-4S2 regeneration interval is approximately 1.5 times as long* as the previous model. The automatic regeneration function can be temporarily turned-off, by using the inhibit switch, based on operating conditions at the time.

*Based on Kubota test. Actual interval depends on each job site and working condition.



Superior power, advanced functionality, and a new 2-pump system combine for greater productivity and smoother operation.

WORKING PERFORMANCE

2-pump Load-Sensing Hydraulic System

A new 2-pump load-sensing system improves the overall smoothness of operations when using front attachments, letting you effortlessly perform simultaneous operations. You'll notice the difference when simultaneously operating the front working group while traveling.

Conventional Tail Swing and Compact Machine Width

Thanks to its contoured, tight tail design created by the shorter rear overhang, the KX080-4S2 has excellent stability, can handle a wider range of loads, and can work in more restrictive spaces. The compact 7'2.6" width of the under-carriage makes it ideal for working in close conditions, and much easier to transport between job sites.

Improved Stability

The new KX080-4S2 has better versatility with approximately 5% more stability when compared to the previous model.

Industrial Digging Force

You need exceptional power when trenching through compacted soil. With the KX080-4S2, elevated productivity levels are certain with the combination of 14,660 lbs. bucket force and 8,554 lbs. arm forces.

The KX080-4S2 powers through those demanding applications so that you can quickly move on to the next job.

Auto-Shift

The auto-shift system enables automatic travel shift from high to low depending on traction effort and terrain. This gives smoother simultaneous operations when dozing and turning.

7' 2.6" (2,200 mm)



Proportional Flow Control of Auxiliary Circuits (AUX1/2) and Maximum Oil Flow Settings

Two auxiliary circuits (AUX 1 & 2) come standard on the KX080-4S2. The convenient thumb-operated switch allows easy proportional flow control of the auxiliary circuit, while a forefinger-operated on/off switch enables simple operation of special applications that require a constant oil flow. The maximum oil flow setting is conveniently adjustable from the digital panel. You can even program up to five oil flow rates corresponding to specific attachments so they can be quickly retrieved for the next job.



Adjustable Maximum Oil Flow Control for Auxiliary Port

This unique function lets you control the oil flow and eliminates the hassle of using tools to change settings manually. The system will even store your settings for the next time you need it. Adjustable oil flow enhances performance and saves fuel.

Auto Idling System

Save fuel with Kubota's Auto Idle. Reduce engine RPM instinctively when high engine speed isn't needed. When the control levers are in neutral for more than 4 seconds, the engine RPM automatically idles. Move any control lever and the engine RPM immediately returns. This innovative feature reduces noise and exhaust emissions while reducing operating costs.



AB Hydraulic Angle Blade (option)

Save time and work more efficiently. With a simple movement of the new thumb operated rocker switch on the dozer lever, the hydraulic angle blade can be angled to the right or left to push soil to the side as the machine moves forward, eliminating the need for repetitive repositioning at right angles when backfilling trenches.



25° Pivot Angle

A. Durable Fixed Hook

B. Bolt-on Cutting Edge*

*Standard on Angle Blade models.

Float Position

You don't need to adjust the dozer height to make a clean ground surface—after backfilling, just travel backward along the covered ditch with the dozer in the float position. Ground finishing work is now fast and easy!



Easy Operation

Up, down, left, and right—the angle blade can be moved and positioned with just a single lever.





A wide and roomy cab brings a new level of operating comfort to the job.

DELUXE INTERIOR

Digital Panel

Informative, interactive and functional, Kubota's Intelligent Control System LCD panel accurately displays timely diagnostic readings and routine maintenance alerts. You'll be kept informed of your current working conditions, engine RPM, temperature and oil levels. These features help reduce downtime and costly repair fees.



Easy-open Front Window

Unlike many excavator windows, the front glass window of the KX080-4S2 opens with ease. Just flip the latch on the side of the window and slide it up. A gas-assist mechanism makes this action almost effortless.



Window Guard (Optional)

Operators need protection from flying chips and debris when using some attachments. On some sites anti-vandalism is important. Kubota provides the window guard mounting points around the front window as a standard feature.

Cab Guttering

The KX080-4S2 features a guttering system to the cab's roof. This helps prevent rainwater from entering the cab, even when the window is open on a rainy day.

Air Conditioner



Overall air circulation in the cab is better than ever, thanks to a stronger cooling/heating unit and the positioning of six vents. Airflow is also directed towards the operator's face for better all-round comfort.



A. Deluxe Suspension Seat

Designed and engineered with comfort in mind, Kubota's high-back suspension seat reduces strain and minimizes operator fatigue. It reclines to accommodate your individual posture, and offers weight compensation, firm wrist support and retractable seat belts.

B. Cup Holder

With the convenience of a bigger cup holder, you can quench your thirst and work longer without leaving the cab. Or store your cell phone*. The charging port is located conveniently close by.

*Cell phones should not be used during machine operation.

C. Movable Console

Raise the safety control lever and the console moves with it, providing more room for entry and exit. To prevent unexpected machine movement during entry or exit, all control levers are then disabled until the console is back in place.

D. TPSS

The Two-Pattern Selection System can shift control styles, whether it's the ISO pattern or the SAE backhoe pattern, with the simple turn of a switch.



Built for long-lasting dependability.

MAINTENANCE & SAFETY



ROPS/OPG (TOP Guard, Level 1)

The OSHA-certified ROPS/OPG (TOP Guard, Level 1) provides protection in the event of accidental rollovers and falling objects.

Bolt-on Handrails

The handrails are bolted to the cab to allow for quick and easy replacement in the event they get damaged.

Underbody Cover

The underbody beneath the engine features a mesh cover to prevent gravel and soil from entering.

Steel Crawler (Optional)

A rugged steel crawler is an excellent option for using your KX080-4S2 on worksites that may compromise the durability or integrity of the standard rubber crawler. In addition to an 18-inch crawler, an extra-wide 24-inch model is available for increased floatation.

Swivel Negative Brake

The swivel negative brake automatically locks the swivel function in its current position. This prevents unexpected machine movement. It's particularly useful during work on inclines or when transporting the excavator between worksites.

Variable Speed Fan

The variable speed fan drive provides the right amount of cooling efficiency by regulating the engine fan speed according to the ambient temperature after the air passes through the radiator. The benefits are reduced fan noise and fuel savings through effective use of engine output.

Two-Piece Hose Design

Kubota's innovative two-piece hose design for the dozer blade reduces hose replacement time by nearly 60% compared to non-joint types. This design virtually eliminates the need to enter the machine for maintenance.

Double Structure Muffler

The double structure muffler controls increases in muffler temperature caused by automatic regeneration of the DPF.

Tie Down

Tie down points are now installed on the track frame and the cabin.



One-sided Engine Maintenance

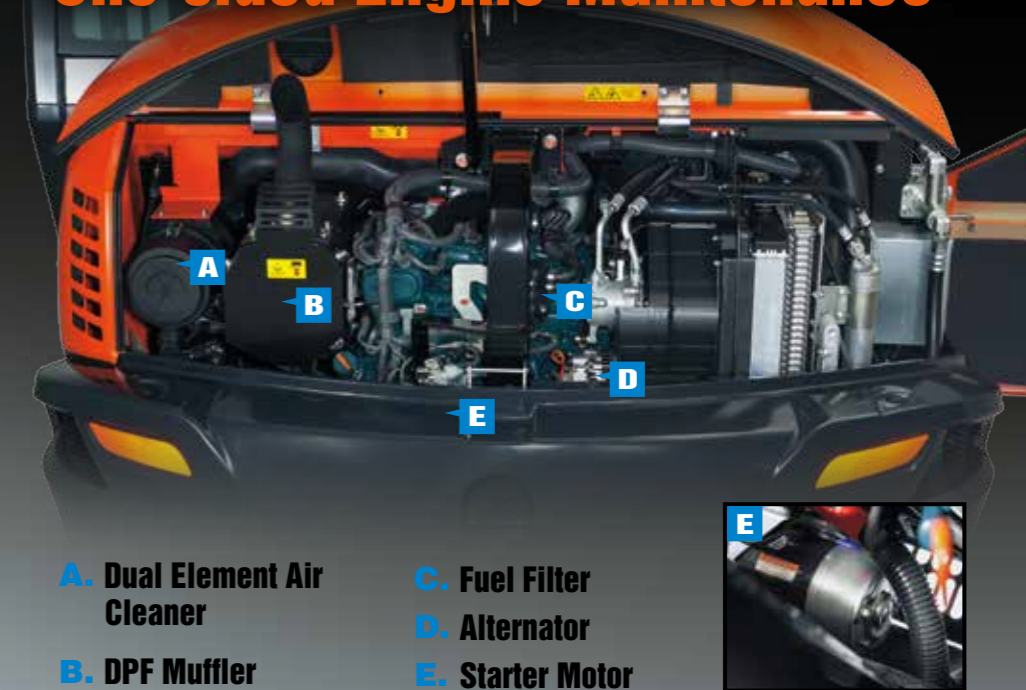

A. Dual Element Air Cleaner

B. DPF Muffler

F. Oil Filter

G. Battery

H. Water Separator

I. Toolbox

C. Fuel Filter

D. Alternator

E. Starter Motor



Triple Opening Hood

All three of the excavator's access panels can open at once. This allows you to easily inspect and view the centrally located components of the KX080-4S2. You can easily access the hydraulic components under the center hood, or the battery, oil filter and tool box under the right hood. Maintaining your excavator has never been this easy.

DIGITAL PANEL



- A. Hour Meter
- B. Coolant Temperature
- C. Clock
- D. Fuel Level
- E. Engine RPM

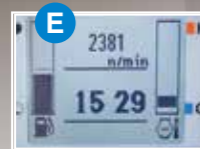

Service Mode



Warning Mode



Operation History Record



Max. Oil Flow Setting (AUX1 and AUX2)

Following the excellence of Kubota's Intelligent Control System, the new digital panel puts convenience at the operator's fingertips. Featuring easier button operation, the user-friendly digital panel is positioned to the front right corner of the operator. This operator-facing wider display greatly improves visibility. With easier access, simpler settings, easy-to-read indicators and alerts, you'll always be aware of the excavator's functioning status.

Operation History Record

Operation history is automatically recorded on the KX080-4S2. You can trace back up to 90 days of the machine's usage dates by simply checking the built-in calendar.

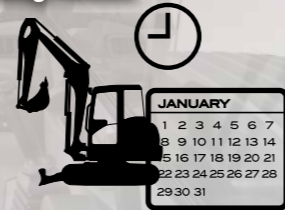

Automatic regeneration mode

The automatic regeneration system automatically burns particulate matter (soot) that accumulates in the diesel particulate filter (DPF) muffler. The soot is burned when the engine is operating at sufficient speed for regeneration. If the engine speed is lower than the required level for regeneration, the indicator requests an increase in the engine speed to keep the accumulation level low and the DPF clean. A service call or DPF filter replacement is required when the accumulated soot reaches a level that reduces the engine speed.



The possibilities are nearly endless with our full range of attachments.

Attachments are the key to getting the most out of your excavator. Use the ones listed below to greatly expand your machine's capabilities. Or, use your own. The Kubota KX080-4S2 allows you to attach excavator attachments you may already have—even ones without a Kubota name on it.



● Hydraulic Thumb



● Hydraulic Breaker*



● Grading Bucket

● Excavating Rake

● Auger

● Brush Cutter*

● Tilt Bucket

● Compaction Wheel

● Vibratory Compactor

● Grading Blade

● Grapple

● Ripper

*The demolition guard is recommended.

WORKING RANGE

Model		KX080-4S2		
A	Max. digging height	ft. in. (mm)	23'11.4" (7300)	
B	Max. dumping height	ft. in. (mm)	17'2.7" (5250)	
C	Max. digging depth	ft. in. (mm)	15'1.1" (4600)	
D	Max. vertical digging depth	ft. in. (mm)	12'7.6" (3850)	
E	Max. digging radius at ground	ft. in. (mm)	23'6.3" (7170)	
F	Max. digging radius	ft. in. (mm)	24'0.6" (7330)	
G	Min. turning radius	W/O swing	ft. in. (mm)	8'2.0" (2490)
		W swing	ft. in. (mm)	6'8.7" (2050)
H	Min. tail turning radius	ft. in. (mm)	4'9.5" (1460)	

LIFTING CAPACITY

LIFT POINT HEIGHT (ft)	LIFTING CAPACITY OVER-FRONT BLADE DOWN unit=1000 lbs				LIFTING CAPACITY OVER-SIDE unit=1000 lbs		
	LIFT POINT RADIUS (ft)			LIFT POINT RADIUS (ft)			
	12	18	MAX.	12	18	MAX.	
GL	12	3.6	3.4	3.4	3.6	2.1	1.9
	8	5.0	3.7	3.4	3.9	2.1	1.7
	4	6.5	4.0	3.5	3.5	2.0	1.6
	0	7.2	4.2	3.6	3.3	1.9	1.6

Machine with cabin and rubber crawler, without bucket

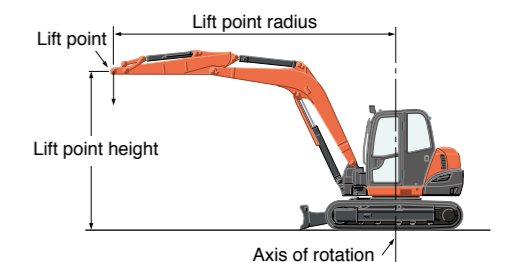
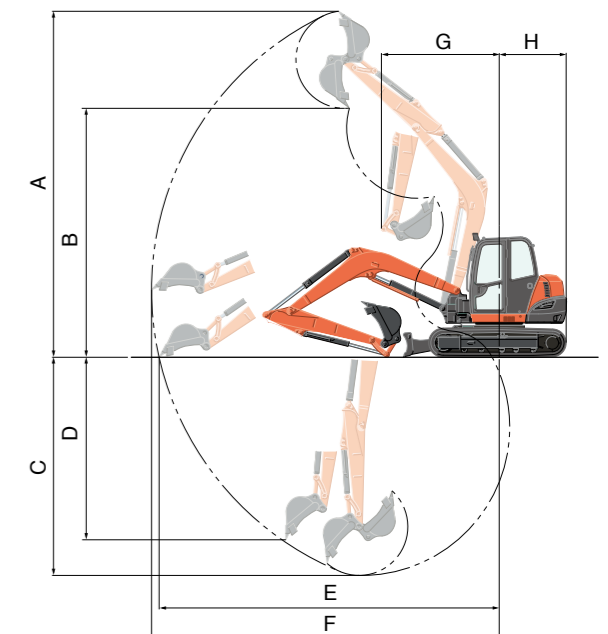

KX080-4S2 OPTIONS

STANDARD EQUIPMENT

Safety system

- Engine start safety system
- Travel motor with disc brake
- Swivel motor with disc brake
- All hydraulic control

Working equipment

- Auxiliary hydraulic circuit 1 and 2 (proportional control)
- 2 working lights on cab and 1 light on the boom
- Thumb bracket and relief valve

Operator's space

- Cab with A/C
- Digital panel with diagnosis function
- Weight-adjustable full suspension seat
- Retractable seat belt

- Hydraulic pilot control levers with wrist rests
- Travel levers with foot pedals
- Two pattern selection system
- 12V power source
- Cup holder
- Horn

Engine/Fuel system

- Double element air filter
- Auto idling system
- Water separator

Undercarriage

- Dozer blade with float function
- 17.7" (450mm) rubber track
- 1 x upper track roller
- 5 lower track rollers on each side
- 2-speed travel switch on dozer lever
- 2-speed travel with auto-shift

Hydraulic system

- Pressure accumulator
- Hydraulic pressure checking ports
- Third line hydraulic return
- 2-pump load sensing system
- Adjustable maximum oil flow on auxiliary hydraulic circuits 1 and 2

Others

- Tool box
- Grease gun holder

OPTIONAL EQUIPMENT

- Beacon lights
- 17.7" (450mm) and 24" (610mm) steel track
- Angle blade with float function and BOE
- Travel alarm