

OPERATOR'S MANUAL

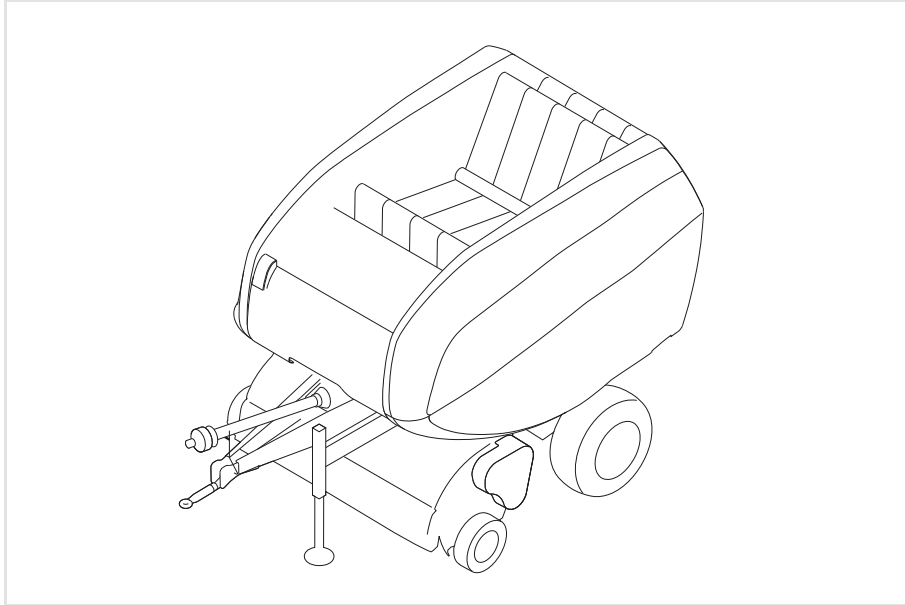

ROUND BALER BV5160 - BV5200



User manual

Original user manual

Model Year	2021
Language	US
Document number	9820H08US-KU

READ AND KEEP THE MANUAL



Machine identification

In order for your dealer to assist you as efficiently as possible, you will need to provide some information about your machine. Please enter the details here.

Designation	BV5160 - BV5200
Operating width	
Weight	
Machine number	from KB172281 to -
Accessories	
Address of supplier	
Address of manufacturer	Kverneland Group Ravenna Srl Via Alcide De Gasperi 34 48026 - Russi (RA) Italy

Table of contents

Foreword	5	Preliminary operations	67
Abbreviations	6	Handling and loading instructions	67
Introduction	7	Packing and unpacking	67
Introduction to the manual	7	Loading and unloading	68
Reference standards	8	Preliminary checks and inspections	71
Symbols used	9	Machine-tractor combination	71
Manufacturer and machine identification	10	Coupling the machine to the tractor	77
Procedure to request technical assistance	11	Uncoupling the machine from the tractor	81
Warranty conditions	11	Storing the machine at the end of season	83
Annexed documentation	11	Putting the machine back into service	84
Glossary and terminology	11	Decommissioning the machine	85
Safety rules	13	Scrapping the machine	86
Purpose of this manual	13	Machine disposal	86
General safety regulations	14	Recommendations for use and operation	86
Danger, warning and caution labels	27	Instructions and advice for use	89
Danger zones	35	Road travel	92
Permissible slopes	35	Using the machine	95
Signaling devices	36	Features of the "FOCUS" control terminal	95
Safety devices on board the machine	37	Description of controls	95
Working at night	38	General description of the equipment	96
Improper use	39	Icon descriptions	99
Residual risks	39	Parameter programming	105
General description of the machine	43	Lock screen	106
General description	43	Work screen	108
Main components	44	Preparing work: binding settings	111
Operating cycle	45	Bale diameter setting	113
Equipment	48	Bale density setting	114
Accessories available upon request	49	Field operation	120
Hydraulic devices	50	Working settings Menu	126
Electronic and electrical devices	51	Warnings menu	129
Technical data	53	Counters Menu	131
Technical data BV 5160 R	53	Configure Buttons menu	132
Technical data BV 5160 SC	56	Advanced Settings menu	133
Technical data BV 5200 R	59	Alarms list	136
Technical data BV 5200 SC	62	Maintenance and adjustments	139
Technical data of the electronic control panel	65	Recommendations for adjustments	139
		Recommendations for maintenance	139
		Recommendations for parts replacements	140
		Scheduled maintenance intervals chart	140
		Lubricant table	145
		Tightening torque table	146
		Lubrication points diagram	147
		Lubrication of shaft with brake (optional)	149
		Cleaning the machine	150
		Extraordinary maintenance	150
		Malfunction information	151
		Problems - Causes - Solutions	151
		General maintenance of the machine	157
		Opening the guards	157
		Checking the safety screws' tightening torque	

Table of contents

158			
Changing the reducer oil	158		
Adjusting the transmission chains	159		
Adjusting the centralized lubrication system (if present on the machine)	160		
Topping up the centralized lubrication system's oil	162		
Adjusting the cleaning rollers	163		
Checking the belts' alignment	165		
Adjusting the belts' alignment	166		
Cleaning the belt guiding rollers	169		
Replacing the baling chamber's belts	171		
Manual equipment for vise ("MATO" type junctions)	173		
Replacing the tires	179		
Pick-up unit (extra-wide type)	183		
General description	183		
Hydraulic devices	184		
Handling the pick-up unit	184		
Unblocking the pick-up unit	185		
Adjusting the pick-up unit's suspension	186		
Adjusting the height of the pick-up unit	187		
Adjusting the tilting baffle plate	188		
Adjusting the pick-up unit's transmission chain	189		
Feeding unit (rotor)	191		
General description	191		
Electrical devices	192		
Hydraulic devices	192		
Unblocking the feeding unit	193		
Feeding unit (Supercut)	195		
General description	195		
Electrical devices	196		
Hydraulic devices	196		
Unblocking the feeding unit	197		
Knives' replacement	198		
Sharpening of knives	199		
Feeding unit (powercut)	201		
General description	201		
Electrical devices	202		
Hydraulic devices	202		
Unblocking the feeding unit	203		
Positioning of knives	204		
Knives' replacement	205		
Sharpening of knives	207		
		PowerBind net binder	209
		General description	209
		Electrical devices	210
		Re-stocking the net reel	211
		Adjusting the braking device	213
		Adjusting the cut reset device	214
		Adjusting the shockproof springs	215
		Adjusting the compensation springs	216
		Adjusting the RESET/START position sensor	217
		Cutting device activation and deactivation	218
		Twine binding unit (electronic)	219
		General description	219
		Electrical devices	220
		Inserting twine	221
		Re-stocking the twine reels	225
		Adjusting the twine tightening clamps	228
		Adjusting the chains on the twine guide arms	229
		Replacing the blade	230
		A01 - Wiring diagrams	233
		A02 - Hydraulic diagrams	251
		Index	263

Keep this manual in a well-known and easily accessible place, in order to have it always at disposal when you need to read it.

The Operator's Manual must be kept in the special document compartment on the machine or in the driver's seat of the corresponding tractor.

Important

The text of the document is the translated version of the Italian manual (original language).

Warranty conditions: Kubota's Express Limited Warranty

CALIFORNIA PROPOSITION 65

 **WARNING:**

Cancer and reproductive harm - www.P65Warnings.ca.gov

Foreword

You are now the proud owner of one of our Equipment models. This vehicle is the product of our quality engineering and manufacturing. It is made from high quality materials, in accordance with a strict quality control system. It will provide you with reliable, long-lasting service. In order to obtain the best use of your vehicle, please read this manual carefully. It will help you become familiar with the vehicle's operation, and contains many helpful suggestions regarding the vehicle's maintenance. While this manual contains instructions for minor maintenance operations, information regarding major repairs can be found in the Manufacturer's Work Shop Manual, and these should only be performed by an authorized Technician. It is the Manufacturer's policy to make use of every advancement in its research as quickly as possible. The immediate use of new techniques in the manufacture of our products may cause small portions of this manual to become outdated. The manufacturer's distributors and dealers are always kept up-to-date with the latest information. Please do not hesitate to consult with them.

Abbreviations

Abbreviation	Description
ASABE	American Society of Agricultural and Biological Engineers, USA
ASTM	American Society for Tasting and Materials, USA
DIN	Deutsches Institut für Normung, GERMANY
fpm	Feed per Minute
Km/h	Kilometers per Hour
m/s	Meters per Second
PTO	Power Take Off
rpm	Revolutions per Minute
rps	Revolutions per Second
SAE	Society of Automotive Engineers, USA

Introduction to the manual

This manual provides the information necessary for the use and ordinary and extraordinary maintenance of the machine.

For this reason, the following data are **ALWAYS AND EXCLUSIVELY** intended for specialized users who have been properly trained, and are capable of interacting with the product in a manner that is safe for themselves, for third parties, and for the environment.

The diagnostic interpretation of any faults and anomalous conditions must be carried out by following the functional verification and intervention operations in full compliance with the regulations provided in this document.

The use, maintenance, detachment, reattachment, disassembly and assembly procedures have been prepared according to the following criteria:

- safety of exposed persons and the environment;
- optimization of the response times;
- reliability of the interventions;

without prejudice to the requirements and recommendations described herein, the use of adequate tools and equipment, and the necessary diagnostic/organizational planning and spare parts provisioning capabilities.

The technical/documentation relationship with the Manufacturer, and the consequent updating of the technical documentation (Operator's Manual and Spare Parts Manual) validated and disseminated by Kverneland Group Ravenna srl, allow for both the services required by the user and those provided under warranty to reduce the negative impact of "downtime", to satisfy the Customers in terms of delivery speed and price/quality ratio, as well as to confirm the workshop's added value.

In order to ensure the product's proper use and handling, it is necessary to guarantee the legibility and proper preservation of the manual, even for future reference.

In the case of deterioration, or even for mere technical and operational updating purposes, please contact the Kverneland Group Ravenna srl Service Department directly.

This document is not contractually binding; Kverneland Group Ravenna srl is committed to a policy of continuous improvement and reserves the right to change the information contained in this document at any time without prior notice.

The procedures and illustrations contained in the manual have been established based on the information available at the time in which the document itself was prepared. There could therefore be inconsistencies between the instructions contained in the Operator's Manual and the models in your possession.

Introduction

REPRODUCTION PROHIBITED

The reprinting, copying and translation of this document (even partially) without the written permission of the manufacturer is strictly prohibited.

Reference standards

For any information regarding usage or maintenance interventions not expressly indicated and/or described within this document, always contact exclusively the Kverneland Group Ravenna srl Service Department.

Before proceeding with consultation, be sure to identify the model by using the identification plate affixed to the machine itself.

With the exception of certain situations or wherever expressly indicated, all the units of measure are expressed according to the International System.

The left and right side indications contained within the manual refer to the sides identifiable by the operator while seated in the driver's seat.

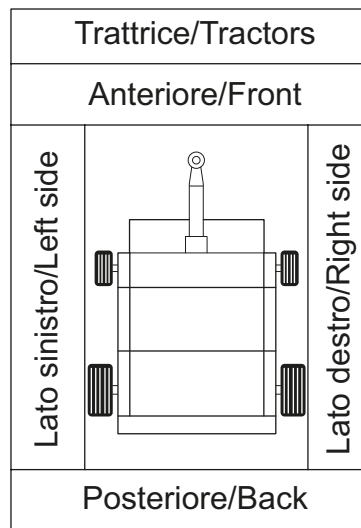

Symbols used

In order to facilitate the reading of the Operator's Manual, appropriate symbols have been included in order to highlight any warnings, risk situations, recommendations, requirements, practical advice, and simple clarifications.

SAFETY FIRST

This symbol, the industry's "Safety Alert Symbol", is used throughout this manual and on the labels affixed to the machine itself in order to warn of the possibility of personal injury. Read these instructions carefully. It is essential that you read the instructions and safety regulations before attempting to assemble or use this unit.

Any failure to observe this safety information could result in:

- Serious machine malfunctions
- Damage to the machine
- Personal injury or accidents.

DANGER

Indicates an imminently hazardous situation which, if not avoided, could result in death or serious injury.

WARNING

Indicates a potentially hazardous situation which, if not avoided, could result in death or serious injury.

CAUTION

Indicates a potentially hazardous situation which, if not avoided, could result in minor or moderate injury.

NOTICE

This symbol indicates critical technical and operating information concerning the safety of individuals or the machine itself.



This symbol indicates operations to be carried out EXCLUSIVELY by authorized technicians with the necessary skills in the relevant sector.

Introduction

Manufacturer and machine identification

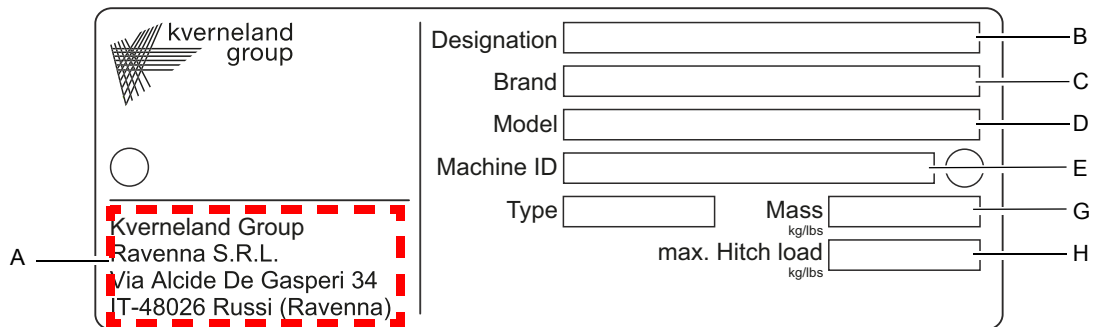

The displayed identification plate is directly affixed to the front machine. It contains the traceability information and the references to be used when requesting technical support and/or ordering spare parts.

The identification plate also specifies the minimum instructions necessary for coupling the machine to the tractor.

- A) Name of the manufacturer
- B) Machine designation
- C) Machine brand
- D) Machine model
- E) Serial number
- G) Overall weight (kg/lbs)
- H) Weight on the towing eye (kg/lbs)

Procedure to request technical assistance

If technical support is required, contact your local authorized dealer. If requesting technical support concerning the machine, specify the data indicated on the identification plate, the approximate hours of use, and the type of problem encountered.

Warranty conditions

Any improper use, unauthorized changes, and/or improper or overdue maintenance operations will render the warranty null and void.

Annexed documentation

The specified documentation is supplied together with the manual and/or as an annex.

- Declaration of conformity
- Testing certificate
- Declaration of conformity with the type of machine that has been type approved for road use (only in Italy). The declaration of conformity with the approved type must be used to request certification for road use from the Traffic Control Authorities.
- Documentation of installed commercial components (e.g., regarding the PTO shaft)
- Wiring diagrams
- Hydraulic diagrams
- Quick guide.

Glossary and terminology

Certain terms that are widely used throughout the manual are described below in order to better explain their meanings.

- **Training:** a process aiming at transferring the knowledge, skills and behaviors required to work in an autonomous, correct and hazard-free manner.
- **Routine maintenance:** the operations necessary to maintain the machine's functionality, efficiency, and safety requirements. The manufacturer establishes the intervention intervals and, if necessary, also indicates the execution methods for operations involving special procedures.
- **Extraordinary maintenance:** the operations aimed at restoring the safety and/or functionality of one or more of the machine's parts with component replacement or repair interventions. These interventions must be performed by personnel with specific technical skills at workshops that are properly equipped and authorized by the manufacturer.
- **Operator:** a person who has been selected and authorized from among those qualified, with the competence and knowledge necessary to drive the tractor to which the machine is connected, and who is capable of performing the production activities autonomously and in an adequate, correct and risk-free manner.
- **Experienced maintenance personnel:** personnel who are authorized to perform routine and extraordinary maintenance interventions upon the machine, with the technical competences and professional skills necessary to operate in a correct and risk-free manner.
- **Authorized workshop:** a workshop that has been selected and officially authorized by the manufacturer to perform routine and

Introduction

extraordinary maintenance operations.

- **Danger zone:** any area inside and/or near the machine where the presence of persons may represent a risk for their health and safety.

Purpose of this manual

- This manual is intended to provide the operator with the “User instructions” necessary to prevent and minimize the risks during the human-machine interactions.
The operator must be properly trained in order to acquire the skills necessary to carry out the work operations under safe conditions. This manual also includes information for the maintenance technician who is authorized to carry out routine maintenance interventions.
- All the information is provided in the Manufacturer’s native language (Italian) and can be translated into other languages in order to meet the legislative and/or commercial requirements.
- The translations into the language of the country of use, provided by the manufacturer, have been carried out directly using the “ORIGINAL INSTRUCTIONS”.
If the translations have been performed by an agent or the subject that has introduced the machine into the linguistic zone in question, the translation must be carried out using the original instructions, and must contain the following message: “TRANSLATION OF THE ORIGINAL INSTRUCTIONS”.
- The information is intended to raise the users’ awareness so that they will pay special attention to all the foreseeable risks. Always use maximum caution. Safety is also in the hands of any personnel who interact with the machine throughout its service life.

 **NOTICE**

Be sure to carefully read the instructions contained in the supplied manual, as well as those affixed directly to the machine; make sure that you have understood them well, especially the safety instructions.

- Be sure to dedicate the necessary time to reading the instructions in order to prevent unfortunate accidents. Once an accident occurs, it is too late to remind you that should have behaved differently.

 **NOTICE**

Keep this manual in a known and easily accessible place in order to always have it at your disposal for consultation. The Operator’s Manual, which constitutes an integral part of the machine, MUST ALWAYS BE KEPT IN THE CAB of the tractor to which the machine is connected.

- In order to easily locate the specific topics of interest, please refer to the table of contents and the index.
- Certain items of information contained in the manual may not entirely correspond to the actual configuration of the delivered machine. This does not however affect their comprehension and does not compromise the level of safety.
- The manufacturer reserves the right to modify the manual without providing advance notice, provided that this does not compromise the health and safety of the workers.
- In order to highlight certain essential parts of the text, and to indicate important specifications, a number of symbols have been adopted, whose meanings are described in the specific chapter.

General safety regulations

General precautions



NOTICE

Be sure to read the following information carefully.

- Always make sure that you have fully understood the contents of the Operator's Manual before performing any operations.



DANGER

Any failure to comply with procedures, recommendations, requirements, or health and safety regulations described and/or referenced (together with standards of good practice) could result in situations of risk for people, property, and the surrounding environment. Unreliable interventions could pose a potential hazard to the user/operator.

- The machine must be stored and maintained in dedicated areas where suitability has been found to comply with the current health and safety regulations.
- Define the areas to be used by the maintenance personnel by providing sufficient areas for all the necessary intervention, tooling, and disengagement activities.
- Follow the procedures contained in the Following Chapters and always be sure to verify the efficiency and reliability of instruments and equipment to be utilized in advance.
- Handling and lifting operations (if necessary) must be performed by qualified personnel in accordance with the following instructions and in compliance with the current accident prevention regulations.



NOTICE

Any other uses or functions not included or expressly indicated in the following pages are to be considered **PROHIBITED**.

It is **STRICTLY PROHIBITED** to make any changes to the product, components, and/or the technical characteristics declared by the manufacturer.

- When designing and manufacturing the machine, the manufacturer paid special attention to the aspects that could pose potential risks to the health and safety of the individuals working with the machine.
- In addition to ensuring compliance with the laws in force, the manufacture also applied all the "good manufacturing techniques", which include the EC machinery directive and the applicable ASABE/SAR standards.
- Be sure to carefully read the instructions contained in the supplied manual as well as those affixed directly to the machine. Make sure that you have understood the instructions well, especially the safety instructions.
- Be sure to dedicate the necessary time to reading the instructions

before using the machine or performing any maintenance operations.

- Always respect the current workplace safety laws, accident-prevention regulations, and the highway code.
- Pay attention to the instructional and safety labels affixed directly to the machine. The instructional and safety labels can have different colors and shapes to indicate dangers, obligations, prohibitions, and instructions.
- The instructional and safety labels must be kept legible, and the instructions specified therein must be respected.
- If any of the instructional and safety labels are damaged, have them immediately replaced by contacting the manufacturer.
- Do not tamper with, circumvent, remove, or bypass any of the safety devices installed on the machine. Any failure to observe this requirement could seriously compromise the health and safety of the individuals present.
- All the personnel called upon to perform any types of interventions upon the machine throughout its entire service life must have recognized competence and skills in the specific sector. If these requirements are not met, the health and safety of the individuals present could be compromised.



NOTICE

Any failure to observe the information provided could pose risks to the health and safety of individuals and could result in unforeseen expenses.

Safety regulations for loading and unloading

- The personnel in charge of loading, unloading, and handling the machine must have the skills and competence necessary for the specific sector and must be fully qualified to use the relative equipment.
- If the machine ever needs to be loaded and unloaded from a means of transport during the course of its service life, the personnel in charge must comply with the information directly indicated upon the machine itself, as well as on its packaging, and in the user manual.
- Lift and transport the machine using suitable means with an adequate capacity.
- Before loading the machine using a tractor, disconnect the PTO shaft from the tractor and the feeding system (electric power, hydraulic system, etc.).
- Before disconnecting the machine from the tractor, position the support leg in such a way as to facilitate its subsequent reconnection.
- Before transferring the machine onto a means of transport, make sure that the machine and its components have been properly secured and that their encumbrance does not exceed the maximum foreseen overall dimensions. Arrange for appropriate

Safety rules

signage if necessary.

NOTICE

Any failure to observe the information provided could pose risks to the health and safety of individuals and could result in unforeseen expenses.

Safety regulations for road travel

- The machine may ONLY travel on the road if it has been type approved in accordance with the highway code in force in the country of use.
- In the case of road travel, the driver must check the wear status and the pressure of the tires, and must make sure that the signaling devices are visible and functioning properly.
- Always remove any product residue and dirt from the machine so that they will not be dropped along the roadway, as these could pose a risk of accidents for other drivers.
- In the case of road travel, the driver must comply with the traffic regulations in force by the machine's country of use, and must drive in such a way as to ensure the safety of other drivers on the roadway.

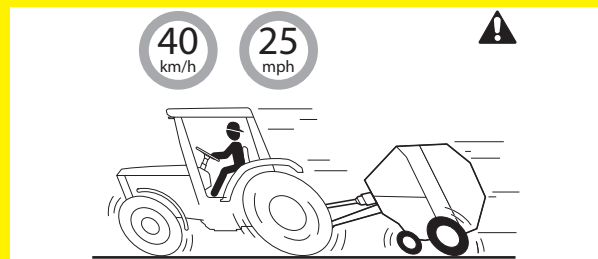

- Always comply with the speed limits. Adapt your speed based on the general driving conditions (heavy traffic, winding roads, etc.).
- Do NOT drive the machine “recklessly”.
- Do not use the machine as a means for transporting people or objects.
- During road use, the baling chamber must be closed and empty (without a bale present).
- Road transfers (even for short journeys) may ONLY be performed with the machine properly attached to the tractor and in the designated configuration.
- Before road use, check to make sure that the PTO shaft has been correctly connected to the power take-off, which must be disengaged, and that the pick-up unit has been raised and secured.

NOTICE

Any failure to observe the information provided could pose risks to the health and safety of individuals and could result in unforeseen expenses.

Safety regulations for use and operation

- The operator must read and fully understand every part of the Operator's Manual.

- The machine's operator (driver) must have the competence and skills necessary for the type of work to be carried out and must be in the appropriate conditions to perform the activity in a safe manner.
- In addition to being properly trained and documented to use the machine, upon first use the operator must simulate certain test maneuvers in order to identify its main controls and functions.
- The machine must NEVER be used by any operators who are insufficiently trained, unauthorized, or unable to read and understand the information.
- During normal working conditions, the machine must be driven by a single operator (driver) in the tractor driver's seat. The operator is responsible for driving the machine and operating the various controls to activate its functions.
- The machine has been designed and manufactured to meet all the operating conditions indicated by the manufacturer. Tampering with any devices in order to obtain different performance characteristics could compromise the health and safety of individuals and could result in unforeseen expenses.
- Do not tamper with any devices in order to obtain different performance characteristics than those foreseen by the manufacturer.
- The machine must only be coupled to tractors of an appropriate category and with appropriate characteristics in order to avoid altering its stability, weight distribution, and braking functions.
- Wear appropriate personal protective equipment (PPE).



- Connect the machine to the tractor's tow bar in such a way that it will not become accidentally unhooked under normal operating conditions.
- The hitch pin must be in good condition. The hitch pin must not show any signs of wear and must be properly mounted. If this is not the case, the hitched machine could become detached, thus posing a potential risk of serious or fatal accidents.
- In certain countries a Safety Chain is required as an auxiliary attachment system in order to retain the connection between the towing and towed agricultural equipment in the event that the primary attachment system should become detached.
- The chain must be connected to a fixed point of the tractor at a minimum height of approximately 1100 mm (43.31") from the ground and to the drawbar of the machine with a tension that is such as to guarantee that, in the event the primary attachment should become detached, contact with the ground is prevented and an acceptable residual maneuverability of the trailed machine is ensured.
- Be sure to use a safety chain with a minimum capacity that corresponds with the total weight of the machine itself. Any failure to respect this requirement could result in serious or fatal injuries.

Safety rules

- Make sure that the coupling pins are properly inserted and locked using the special locking pins in order to prevent accidental disconnections.
- Do NOT connect or disconnect the machine from the tractor without ensuring the necessary safety conditions in order to prevent the risk of crushing. A risk of crushing may occur if the operator remains in the area while the machine is being connected to or disconnected from the tractor.

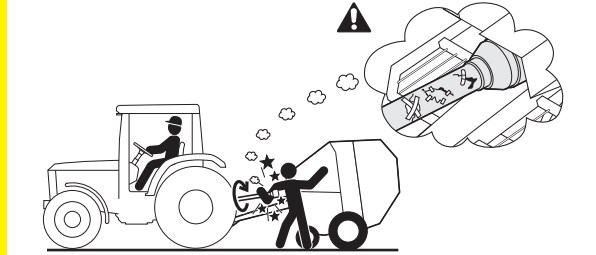

- Be sure to connect the PTO shaft correctly with the safety devices functioning properly.
- Connect the PTO shaft FIRST to the machine and then to the tractor's power take-off.
- ALWAYS connect the safety chains properly in order to prevent the PTO shaft's protection devices from rotating.
- Most accidents (even fatal ones) are caused by improperly installed and poorly maintained safety devices.
- Make sure that the PTO shaft complies with all the current safety standards and regulations.
- Only use the PTO shaft supplied along with the machine or an original replacement part. Do not use shafts supplied with other machines.
- Before installing the PTO shaft, disengage the power take-off, lower all the implements to the ground, place all the controls in their neutral or park positions, engage the parking brake, stop the tractor, and remove the ignition key.
- Before engaging the PTO, make sure that the PTO shaft has been correctly installed and that the direction of rotation and maximum speed comply with the machine's operating parameters.
- If the PTO shaft supplied with the machine is equipped with a shear bolt and the latter has to be replaced, use an original spare part with the same feature specified in the technical data table.
- Never engage the PTO when the tractor's engine is off and while the PTO shaft is connected. In the event of an accidental engine start-up, the safety conditions are no longer suitable to ensure the safety of the individuals in the machine's vicinity.
- Further information regarding the PTO shaft can be found in the manual issued by its manufacturer.
- The machine must only be used for the purposes indicated by the manufacturer. The machine's improper use could pose risks to the health and safety of individuals and could result in unforeseen expenses.
- Before using the machine, make sure that the guards are perfectly installed and that all of the guards' blocking devices are properly engaged.
- Do not use the machine if the safety devices are not properly installed and maintained. Any failure to meet this requirement

could pose serious risks to the health and safety of individuals.

- ALWAYS wear the personal protective equipment indicated in the Operator's Manual and those required by the current workplace safety regulations.
- ONLY wear approved shoes and clothing in order to activate the controls properly and to avoid becoming entangled in the moving parts.

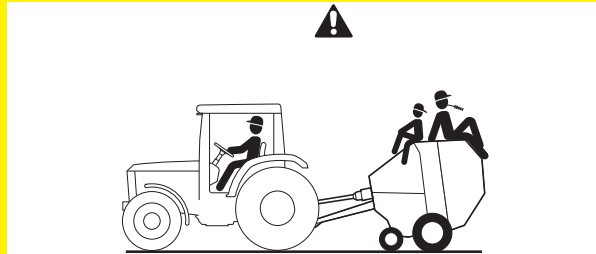

- Do NOT carry people (especially children or handicapped people), pets, or other objects in the tractor's cab or on parts of the machine. They could fall or cause serious accidents or interfere with the safe operation of the machine.
- **Children's Safety:** tragic accidents could occur if the operator does not use caution in the presence of children. Children tend to be attracted to these types of machines and the work that they are performing. Never assume that children will remain where you last saw them.

To prevent accidents, follow the precautions below:

- keep children away from the work area and make sure they are supervised by another responsible adult.
- be alert and shut down the machine immediately if any children enter the work area.
- always look behind you to make sure no children are present before and during any reverse maneuvers.
- never allow children to play on or operate the machine or the equipment connected to it, even while the machine is off.
- never allow children to operate the machine, even under adult supervision.
- use extra caution when approaching blind corners, plants, trees, or anything else that could obstruct your view of places where children could be hidden.
- Do NOT continue using the machine if any anomalies are encountered. Stop the tractor and only restart it once the normal operating conditions have been restored.
- Do not allow any unauthorized individuals (especially children, the elderly, people with disabilities, and domestic animals) to approach the operating area while the machine is in use. If necessary, stop the machine immediately and instruct the unauthorized individuals to leave the hazardous areas.
- Do not leave the machine unattended while the tractor is running.
- The machine must always be used with the personal protective equipment indicated in the manual and what is required by the current workplace safety regulations.
- Before operating the machine, check to make sure that all the protection devices have been properly installed and are functioning correctly, and that all the hook-ups and connections (hydraulic, electrical, etc.) have been carried out in a suitable manner.

Safety rules

Furthermore, the notification and signaling devices must be clearly visible and working properly.

- During pick up of the products, evaluate their typology (short, dry, etc.) and follow the indications in the operation manual to avoid flooding.
- Do not try to clear the machine or remove the clogging while the tractor is running. Stop it in safe conditions with the power take-off disengaged, the engine off, and the ignition key removed.
- Always disengage the power take-off to stop the machine's functions during reverse driving, transfers, or maneuvers involving excessive steering.
- In the case of steep terrain, adapt the machine's speed based on the slope and stability of the terrain itself.

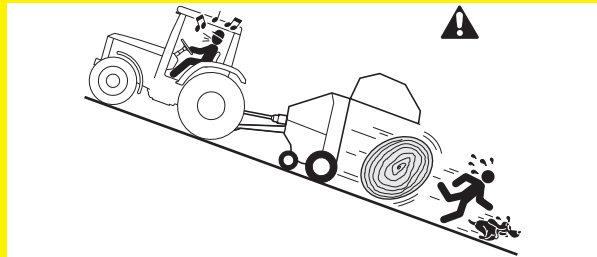

- Be very careful when working on steep terrain to avoid the risk of overturning.
- In the case of terrain where the slope can cause risks of sudden and uncontrolled bale movements, unload the bale crosswise to the slope. This precaution can be particularly useful when the machine is equipped with a bale kicker.
- Do NOT drive the tractor "recklessly". Always adjust the speed to the conditions of the terrain.
- Do NOT turn suddenly or at excessively high speeds in order to avoid loss of stability and the risk of the machine overturning
- Wear approved hearing protection if you are exposed to continuous and /or high levels of noise. In Italy, according to Decree no. 81 of 9 April 2008 (the Consolidated Law on workplace health and safety), noise is considered detrimental to hearing when it exceeds the limit value of 85 dB (A) Leq. Whatever the case, reference must always be made to the national regulations in force in the machine's country of use



NOTICE

Any failure to observe the information provided could pose risks to the health and safety of individuals and could result in unforeseen expenses.

Information for the employer

- The employer must train the operator on the skills required to interact with the machine in a suitable and risk-free manner.
- This training must be planned based on the operator's experience and in accordance with the current laws applicable at the workplace.
- The operator must be informed about any REASONABLY FORESEEABLE MISUSE and RESIDUAL RISKS.

- The operator must demonstrate that he/she has acquired the relevant skills and has understood the “Operator’s Manual” in such a way as to carry out his/her activities in a safe manner.
- The operator must be able to recognize the safety signals and demonstrate that he/she is in suitable condition to carry out the assigned duties period.

Important

The employer must document the operator’s training appropriately so that the relative documents can be produced in the case of controversy.

Preliminary maintenance operations

- The machine must be kept and maintained in dedicated areas where suitability has been found to comply with the current health and safety regulations.
- Do not use gasoline, diesel fuel, or other flammable liquids to wash or degrease any of the machine’s parts.
- Never use open flames.
- Do not perform any maintenance operation with the engine running (without prejudice to the necessities and requirements described on the following pages). Wherever necessary, always prepare the exhaust fume evacuation system in advance and make use of the necessary personal protective equipment (PPE).

**DANGER**

Before initiating any maintenance or inspections of the machine, position the machine on solid level flooring with the wheels blocked by the supplied wedges, the PTO shaft disengaged, the engine off, and the ignition key off. When two or more people are working together, each must pay close attention to the safety of others.

**NOTICE**

Only use the special equipment indicated wherever required. Mark the positions on all connection joints (pipes, cables, etc.) before disconnecting them and identify them with distinctive markings. The bearings must rotate freely with no hardness and/or noise, otherwise they must be replaced.

Reference operators

Any maintenance work is to be completed exclusively by properly trained, educated, and qualified personnel. These are the types of technicians who can intervene on the vehicle for the execution of the various maintenance operations listed in this manual.

Operator: This is the machine’s operator who has received the proper training before operating and using the machine in the field. The operator can perform the machine’s regular and routine maintenance operations.

Maintenance technician specialist: This maintenance technician is a specialized technician who has been trained and qualified to service the machine. The maintenance technician specialist is also the individual who performs the extraordinary maintenance or replacement operations that require an in-depth knowledge of the machine and the mechanical specifications for this type of product.

Employer: This is the person who employs the worker/operator, or in any case, the person responsible for the organization or the production unit in question (based on the type and structure of the organization where the employee works), as they exercise decision-making and spending powers.

CAUTION

In the event that multiple people need to work on the vehicle at once, the competence of each must be defined in advance in a clear and unequivocal manner.

Personal protective equipment

WARNING

In order to work in full compliance with the safety standards, it is necessary to wear protective clothing (as required by law) and to ensure that they are always in perfect condition

The personal protective equipment (PPE) consists of:

- Overalls or other comfortable garments that are not too large and has no possibility that their parts could become caught in the machine's moving elements;
- Safety shoes;
- Protective gloves for the hands.

The specific equipment for maintenance consists of:

- Safety glasses (with side shields) or a face mask for eye protection;
- Respirators (or anti-dust masks);
- Earplugs or headphones for hearing protection

Under particular environmental conditions, such as performing the activities outside, the following equipment may be required:

- Reflective harness;
- A raincoat for bad weather;

- High boots for bad weather

 **WARNING**

Do not wear rings, watches, jewelry, or unfastened or dangling garments, such as ties, torn garments, scarves, unbuttoned jackets, or blouses with open zippers, that could get caught in moving parts.

It is nevertheless recommended to use garments approved for accident prevention.

Check with your employer about the current safety regulations and accident prevention devices.

Safety regulations for maintenance and adjustments

- Keep the machine in properly maintained condition and carry out the routine maintenance recommended by the manufacturer. Proper maintenance will ensure the machine's best possible performance, an extended service life, and constant compliance with the safety requirements.
- Furthermore, proper maintenance will help to prevent the risk of fires during the machine's operating phases.
- Before performing any maintenance and adjustment interventions, be sure to activate all the machine's safety devices.
- Before performing any maintenance interventions in areas of the machine that are hazardous or not easily accessible, prearrange for suitable safety conditions in compliance with the current workplace health and safety regulations.
- Disconnect the power supply before working on the electrical system in order to avoid the risk of personal injury or damage to the machine itself.
- Disconnect the power supply of the electrical system before carrying out welding operations on the machine in order to avoid irreversible damage to the components.

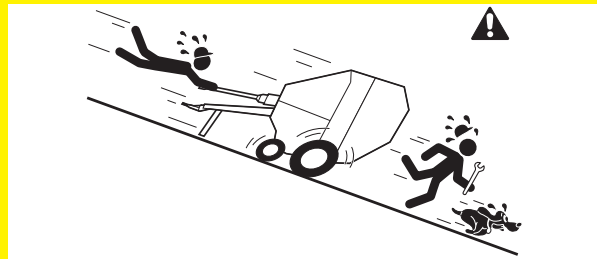

- Perform maintenance and adjustment operations with the machine placed on a level surface, the power take-off disengaged, the implements lowered, all the controls in their neutral or brake positions, the engine off, the ignition key removed, and the wheels blocked.
- During adjustment and maintenance operations on the machine, use proper clothing and/or the personal protective equipment specified by the manufacturer and required by the current workplace safety regulations.
- ONLY replace the components with ORIGINAL spare parts or parts with IDENTICAL designs and functional features.
- NOT replace the components with non-original spare parts or spare parts with different design and functional features.
- The use of similar but not identical spare parts could lead to non-compliant repairs, altered performance levels, and property damage.
- Use the oil recommended by the manufacturer. Do not mix oils of different brands or with incompatible chemical-physical properties.
- Only replace the SAFETY DEVICES with original spare parts in order to avoid altering the required safety levels.
- Regularly check the fastening screws for the main components and tighten them in order to prevent them from becoming dangerously loose.
- Never use the PTO shaft as a pedestal for performing any types of interventions upon the machine.
- Do not disperse pollutant materials into the environment. Dispose of them in compliance with the relevant legislation in force.

- Pressure washing with water may only be done on the machine's external parts and only at the specified pressures.
- NOT pressure wash the seals of the gaskets and bearings.
- NOT wash the internal parts with jets of water, as this could irreversibly damage the machine's electrical and electronic components.
- NOT clean or wash the machine with aggressive products in order to avoid damaging the components.
- ONLY wash or clean the ABS lateral and front guards with water and soap.
- NOT use alcohol and ammonia-based detergents or other aggressive chemical products, as these could irreversibly damage the guards.
- Extraordinary maintenance operations must only be carried out by authorized personnel who must prearrange for all the necessary safety conditions and comply with the specified procedures.
- NOT perform checks and adjustments while the machine is in motion and with an operator on board.

**NOTICE**

Any failure to observe the information provided could pose risks to the health and safety of individuals and could result in unforeseen expenses.

Hydraulic safety

Hydraulic system not pressurized

Hydraulic system interventions must only be carried out if the tractor's and the machine's hydraulic systems are not pressurized.

A pressurized hydraulic system can trigger sudden machine movements and can cause serious personal injuries or damage to the machine.

Serious or fatal injuries can occur as a result.

Use caution during welding operations

Do not perform any welding work near hydraulic hoses.

The hydraulic oil can easily catch fire.

Cleaning the hydraulic system

The quick-release couplings must be closed or disconnected with caution.

Any dirt or air that has entered the hydraulic system must be eliminated.

Otherwise the hydraulic system could be seriously damaged.

Personal injuries or property damage could occur as a result.

Collect the used oil

The used oil is harmful to the environment and must be collected and disposed of in compliance with the applicable national laws.

Hydraulic lines

Replace the flexible hydraulic lines at least every 6 years

The hydraulic lines age without showing visible external signs.

Replace the flexible lines every six years. Use flexible lines having the same technical specifications. The requested information is printed on

Safety rules

the hydraulic line itself.
The defective hydraulic lines may cause serious injuries or death.

Safety rules for the protection of the environment



- Waste consisting of Electrical and Electronic Equipment may contain substances with potentially harmful effects on the environment and on people's health. Be sure to dispose of such waste correctly.
- When the machine is dismantled, sort all the components according to their chemical characteristics and collect them separately in compliance with the laws in force.
- In reference to the WEEE Directive (Waste Electrical and Electronic Equipment), during the decommissioning process, the user must separate the electrical and electronic components and dispose of them at the appropriate authorized collection centers or else return them to the seller upon making a new purchase.
- All the components that must be separated and disposed of in a specific manner must be identified with a special marking.
- The unauthorized disposal of Waste Electrical and Electronic Equipment (WEEE) is penalized by the laws in force in the territory where the offense is committed.



NOTICE

Any failure to observe the information provided could pose a risk to the health and safety of individuals and could result in unforeseen expenses.

Danger, warning and caution labels

Decal descriptions

The illustrations show the safety and information signs applied to the machine. The meaning of each sign is explained on the side.

Danger of entanglement:

do not approach the PTO shaft while the tractor's engine is running and while the PTO is engaged.



Danger of entanglement:

do not approach the PTO shaft while the tractor's engine is running and while the PTO is engaged.



Danger of entanglement:

do not approach any components of the pick-up while the tractor's engine is running and while the PTO is engaged.



Danger of electrocution:

keep a safe distance from the electrical lines.



General warning:
carefully read the Operator's Manual as shown on label and throughout this story prior to initiating any operations with the machine. Observe the safety regulations and instructions while operating the machine.

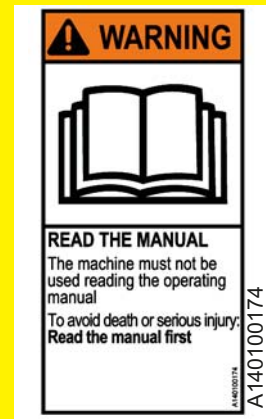

General warning:
carefully read the Operator's Manual prior to operating the machine. Observe the safety regulations and instructions while operating the machine.

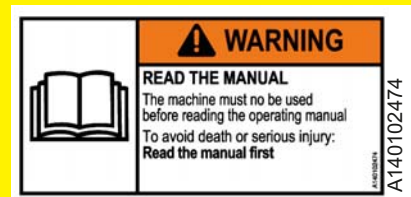

General warning:
prior to carrying out any maintenance or repair work, stop the engine and remove the ignition key.



General warning:
prior to carrying out any maintenance or repair work, stop the engine and remove the ignition key.

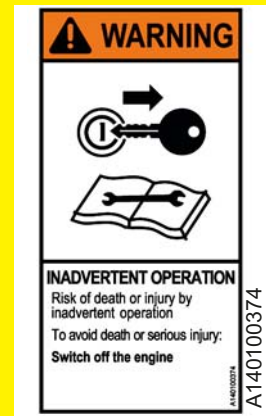

General warning:
prior to carrying out any maintenance or repair work, stop the engine and remove the ignition key.



General warning:
lifting point with hook lifting
equipment.

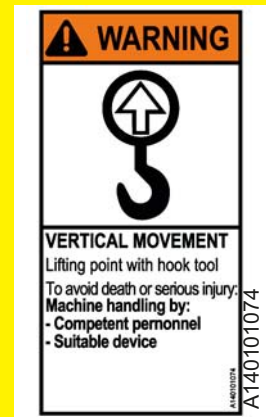

General warning:
lifting point with fork lifting
equipment.



Danger of body crushing:
engage the safety lock prior to
intervening in any potentially
dangerous zones.



Danger of body crushing:
when the tractor's engine is
running, stay clear of the zone
where the gate opens.



Safety rules

Danger of body crushing:

unload the bale in order to prevent the risk of sudden and uncontrolled movements (for example, in the case of extremely steep terrain)



Danger of body crushing:

stay at a safe distance from the raised gate if the safety lock is not engaged.



Danger of body crushing:

when the engine is running, stay clear of the articulations.



Danger of body crushing:

make sure that the wedges have been properly positioned prior to unhooking or parking the machine.



Danger of entanglement:
when the motor is running, do not open or remove the guards.



Danger of body crushing:
prior to intervening in any potentially dangerous zones inside the machine with the gate open, be sure to engage the safety lock.



Danger of entanglement:
when the motor is running, do not open or remove the guards.



Danger of entanglement:
when the motor is running, do not open or remove the guards.



Danger of entanglement:
prior to starting the machine, close the safety guards.



Safety rules

Danger of entanglement:
prior to starting the machine,
close the safety guards.

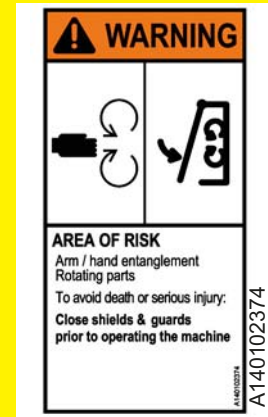

Danger of entanglement:
when the motor is running, do not
open or remove the guards.



Danger of shearing:
keep out of the machine's range
of action.



No parking:
it is forbidden to walk or stand
within the machine's range of
action.
Do not allow any unauthorized
individuals (especially children,
the elderly, and domestic
animals) to approach the
operating area while the machine
is in use.
If necessary, stop the machine
immediately and instruct the
unauthorized individuals to leave
the hazardous areas.



Climbing prohibited:

do not climb on the zone where the signal is applied in order to reach the higher parts of the machine.



General danger:

before engaging the PTO shaft, check the direction of rotation and make sure that the maximum RPM value does not exceed the indicated value.

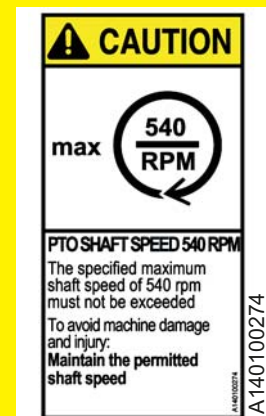

CAUTION

Make sure that all the decals are legible. If they are not, clean or replace them as required, and make sure that the new ones are placed in the original positions.

Locations of the safety decals

Installation or replacement

Important

While the positioning of the decals is approximate, they must never be positioned in locations that are not visible to the operator from the field, and must never cover any parts of any other decals in their immediate vicinity.

- ▶ Using a gentle soap and water solution, thoroughly clean the area where the decal is to be applied.
- ▶ Allow the surface to dry completely.
- ▶ Remove the backing from the decal to expose the adhesive.
- ▶ Position the decal in the recommended position, as shown in the following scheme, and eliminate all the air bubbles.

Danger zones

WARNING

The illustration shows the danger zones where no one should be while the machine is in use. It is the operator's duty to keep such zones out of bounds. If necessary, he/she must turn the engine off and clear the danger zone.

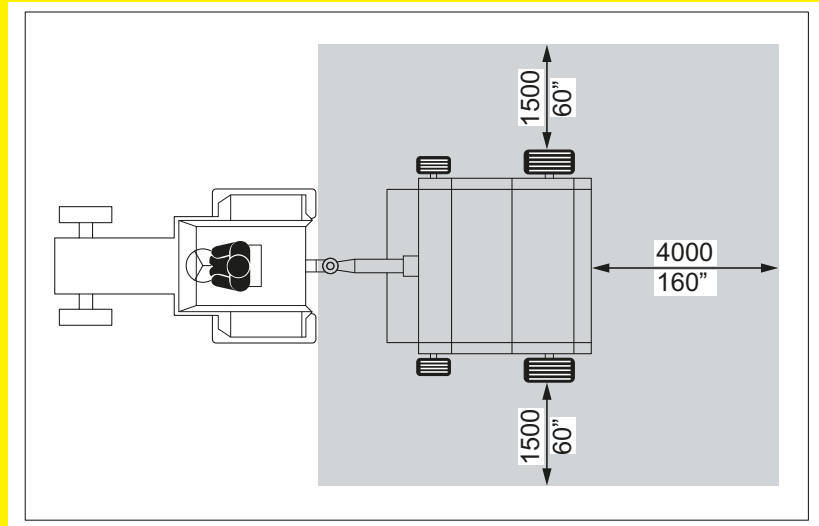

Permissible slopes

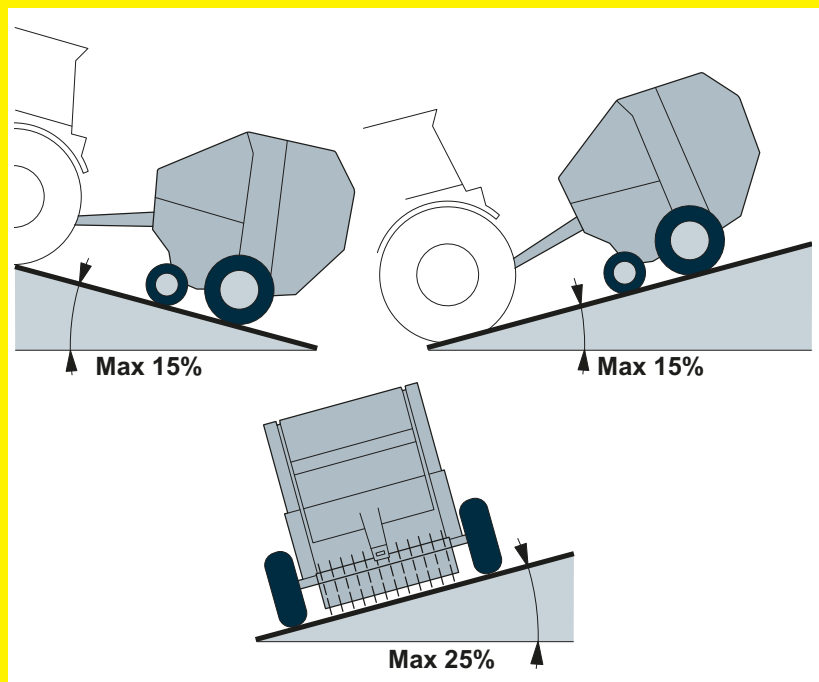

The images shows the maximum permissible slope on solid terrain, free of any hollows and obstacles, with the machine in running order.

! DANGER

Danger of overturning. Do not use the machine on terrain where the slope exceeds the permissible limit or in the presence of other hazards (rises, hollows, etc.) which could limit the stability of the machine.
In the case of steep terrain, adapt the machine's speed based on the slope and stability of the terrain itself.

Signaling devices

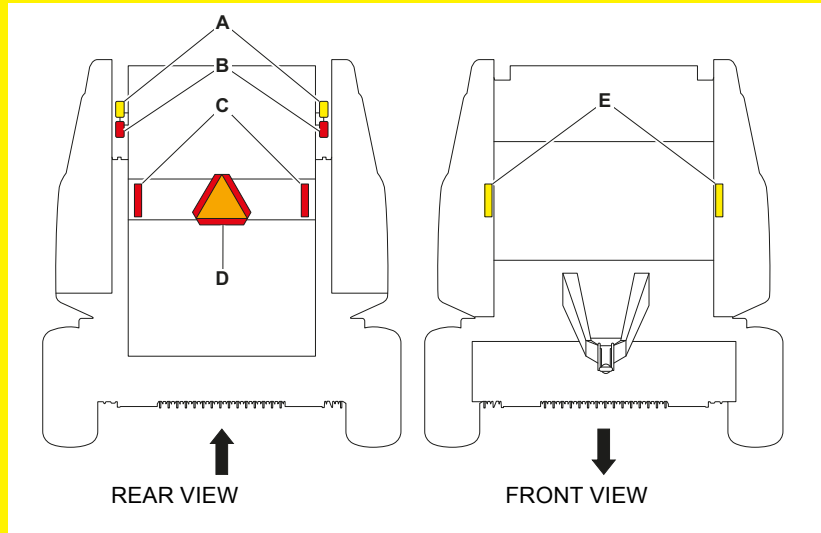

- A) Rear indicators (amber)
- B) Rear lights / Brake lights (red)
- C) Red reflectors
- D) "Slow-moving vehicle - SMV" marking
- E) Yellow reflectors

- The machine is equipped with signaling devices, signs, and stickers that serve to ensure safety during road travel. The signaling devices must be in good working order at all times. The signs and stickers must not be removed. Illegible or missing labels must be replaced. You can obtain new labels as spare parts from your dealer.
- If the implement obstructs the view of any of the tractor's illumination devices from its transport position, the implement must be fitted with appropriate lighting elements in order to take the place of the obstructed lamps. See your authorized dealer for an appropriate lighting kit.
- Additional markings are required for road transport in some U.S. states and some Canadian provinces.
- "Slow-moving vehicle" (SMV) marking: This emblem is used on slow moving vehicles when operated or traveling on public roadways.
 - On slow moving vehicles with maximum speeds of 40 km/h (25 mph) or less, the "Slow-moving vehicle" (SMV) emblem must be utilized.
 - On slow moving vehicles with maximum speeds ranging from 40 km/h (25 mph) to 65 km/h (40 mph), the following emblems

and symbol must be utilized:
the “Slow-moving Vehicle” (SMV) emblem
“Maximum Speed Identification Symbol” (SIS).

Safety devices on board the machine

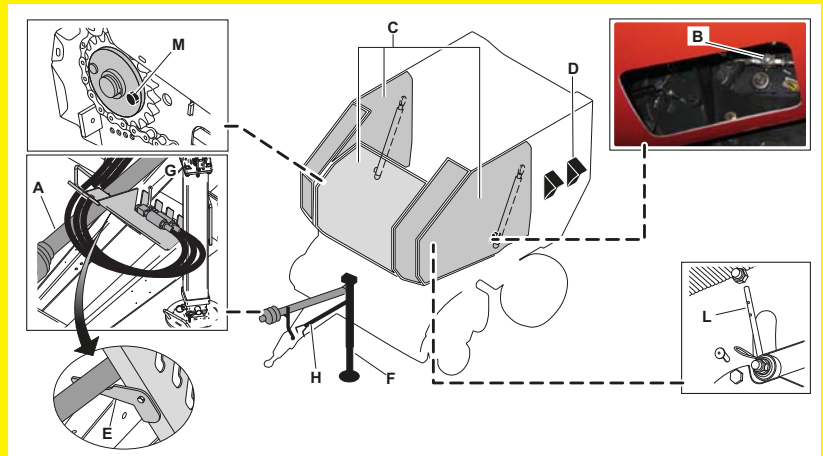

- A) **PTO shaft:** this shaft comes supplied along with the machine and is of a constant velocity type that can be equipped with either a shear bolt or a pawl-type torque limiter. The PTO shaft equipped with a pawl-type torque limiter automatically disengages the movement in the event of a machine jam and/or blockage. The PTO shaft equipped with shear bolt automatically shears the bolt and interrupts the movement in the event of a machine jam and/or blockage.
- B) **Safety lock valve:** This lock valve is used to lock the tailgate in the “open” position so that maintenance operations inside the baling chamber can be carried out under safe conditions.
- C) **Fixed guard:** This guard prevents access to the machine's moving parts. It can only be opened via an intentional action and with the use of a tool.
- D) **Wheel chocks:** If required by the current regulations in the destination market/country, these chocks are used to prevent accidental shifting when the machine is stationary and uncoupled from the tractor.
- E) **Support:** This is used to support the PTO shaft and prevent damage to the plastic cover when it is disengaged from the tractor's PTO.
- F) **Support leg:** The support leg keeps the machine's drawbar in position when the machine is uncoupled from the tractor and facilitates the coupling operation.
- G) **Lock valve:** The lock valve is used to lock the pick-up unit in the “raised” position so that the machine's transfer (during road use) can be carried out under safe conditions.
- H) **Clearing tool:** The tool is used to clear jams and/or blockages in the area of the pick-up unit and/or the feeding unit.
- L) **Safety lock:** This lock is used to deactivate the net binding unit's cutter mechanism in order to perform maintenance operations under safe conditions.
- M) **Pick-up unit shear bolt:** in the case of a blockage, this bolt shears in order to prevent damaging the group or the machine's components. On certain models the shear bolt can be replaced with a torque limiter

Safety rules



NOTICE

ONLY replace sheared “shear bolts” with original spare parts that comply with the requirements.

Some of the listed devices can be replaced with other devices, which are described in the relative chapters.

Round Baler Type	Chamber Width 4ft-5ft	Feeding system	Pickup Type/Dimension	Pickup Driveline Protection	
				Shear Bolt	Torque Limiter
Round Baler Variable Chamber	4ft	Rotor Fork Feeder	Pickup Narrow (1.7 m - 5.6ft) ECONO Models	X	
			Pickup Wide L (2.0 m - 6.6ft) Premium Models	X	
			Pickup Extra Wide (2.2 m - 7.2ft)		X
		Rotor	Pickup Extra Wide (2.2 m - 7.2ft)		X
		Cutter SC14/25	Pickup Extra Wide (2.2 m - 7.2ft)		X
	5ft	EasyFeed Intake	Pickup Extra Wide (2.2 m - 7.2ft)		X
Round Baler Fixed Chamber	4ft	Rotor	Pickup Wide L (2.0 m - 6.6ft)	X	
			Pickup Wide L (2.0 m - 6.6ft)	X	
			Pickup Extra Wide (2.2 m - 7.2ft)		X
			Cutter SC14/25	Pickup Extra Wide (2.2 m - 7.2ft)	

Working at night



WARNING

The machine can even be used at night. Working under such conditions involves an increased number of risks. In order to avoid endangering the health and safety of individuals, all the lighting devices installed on the tractor and on the machine must be functioning properly.



WARNING

If the work area's conditions require it, a preliminary inspection must be carried out in order to identify any hazardous areas (steep terrain, proximity to steep cliffs, etc.) and mark them adequately.

 **CAUTION**

Adjustment, maintenance, and inspection operations may only be performed upon the machine at night if the safety and lighting conditions are suitable.

Improper use

Any use of the machine for purposes other than those envisaged by the manufacturer is to be considered IMPROPER USE.

- Do not circulate on public roads with machines that are not type-approved and have not been properly adapted to ensure the safety of both the driver and the road's other users.
- Do not use the machine as a means for transporting people or objects.
- Do not couple the machine to tractors whose category and features are not suitable.
- Do not use the machine to pick up products that are different from those for which it is intended.
- Do not use the machine to pick up the product (straw, hay, ensiled products, and maize stalks) if it has not been prepared in windrows.
- ONLY replace sheared "shear bolts" with original spare parts that comply with the requirements.

 **WARNING**

In the case of improper machine use, the operator assumes all responsibility (moral, civil, and criminal) for any resulting personal injuries and/or property damage.

Residual risks

Even though the manufacturer has complied with the laws in force and adopted the appropriate standards, the residual risks listed below still remain.

- Danger of lethal "whiplash" if the correct procedures and sequence for connecting the PTO shaft are not respected, and the PTO is accidentally engaged.

 **DANGER**

Do not connect the PTO shaft while the tractor's engine is running, the ignition key is inserted, and the PTO is engaged.

- Danger of entanglement and entrapment with potentially serious (even mortal) consequences if the operator attempts to clear the machine without using the procedures described in the Operator's

Manual or without using the appropriate devices.

WARNING

Do not attempt to clear the machine with the tractor's engine running, the ignition key inserted, and the PTO engaged. Carry out the clearing operations according to the specific procedures.

- If the operator uses the machine at speeds that are not suitable for the ground conditions (steep terrain) and/or with slopes greater than the maximum permitted, the machine could become unstable and/or overturn.

WARNING

Do not use the machine on terrain characterized by risks of instability and/or overturning, such as close to ditches, steep cliffs, loose soil, steep slopes, etc. If these conditions are present, take all the necessary measures to avoid the relative risks.

WARNING

Danger of running into people, animals, or objects during reverse maneuvers when opening/closing the tailgate, and when unloading the bale, are due to the reduced visibility of the area behind the machine from the driver's seat. Use caution when reversing and always look back before reversing.

WARNING

Danger of contact between the upper limbs or other body parts and the machine's components during maintenance operations requires checks to be carried out while the machine's parts are in motion. Respect the maintenance procedures.

WARNING

Do NOT work with an insufficient field of view or in the presence of people within the machine's range of action or objects nearby. Use caution when reversing and always look back before reversing.

WARNING

Do NOT connect or disconnect the machine to the tractor without ensuring the safety conditions necessary to avoid any crushing risks, by stopping the engine or engaging the parking brake for example.

 **WARNING**

Danger of fire if the machine's maintenance and inspection procedures are not performed correctly, especially if there is a bale (partial or complete) inside the baling chamber. Respect the maintenance procedures.

 **WARNING**

Danger of entanglement with the PTO shaft if the protective devices are damaged or are not installed correctly. Install and use proper PTO guards.

Page intentionally left blank

General description of the machine

General description

- The variable chamber round baler is a towed machine, which was designed and manufactured for agricultural purposes and, more precisely, for harvesting windrows of different stem plants (fodders, straw, etc.), in order to compress them into round bales.
- According to the different production need, the machine can be configured in different versions and models (See “Technical Data”).
- The electronic control system, which is positioned close to the driver’s seat in the tractor, manages and enables the machine’s work parameters (bale diameter, binding type, etc.), operating conditions, and operation irregularities.
- The machine allows for the creation of “soft core” or “solid core” bales of different densities and diameters.
- Only one operator is required on the tractor (driver) for the machine’s use and operation. The drivers must meet the necessary requirements and must be suitably trained for the machine’s safe operation and use. Your authorized dealer may be able to assist with training.
- The machine can collect various stem plants, such as straw, hay, and silo fodder, as well as stalks (maize, soy, sorghum etc.). For normal work activities, the machine must be towed by a tractor of an appropriate category and power rating, and must also be equipped with a PTO to power the main devices.
- The tractor must be equipped with PTO, electrical system, and hydraulic system couplings.



WARNING

Wear appropriate personal protective equipment.

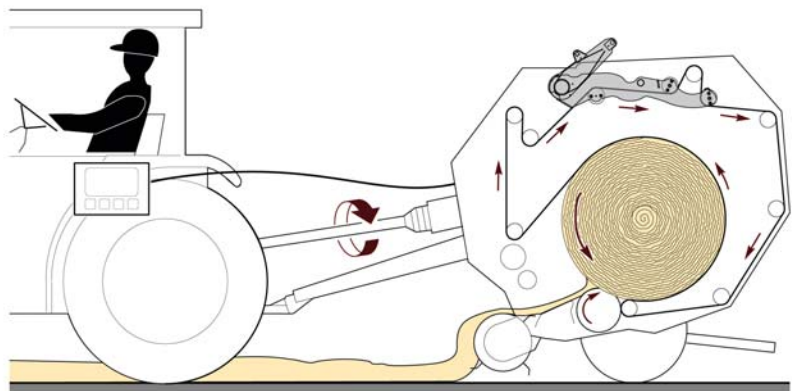

General description of the machine

Main components

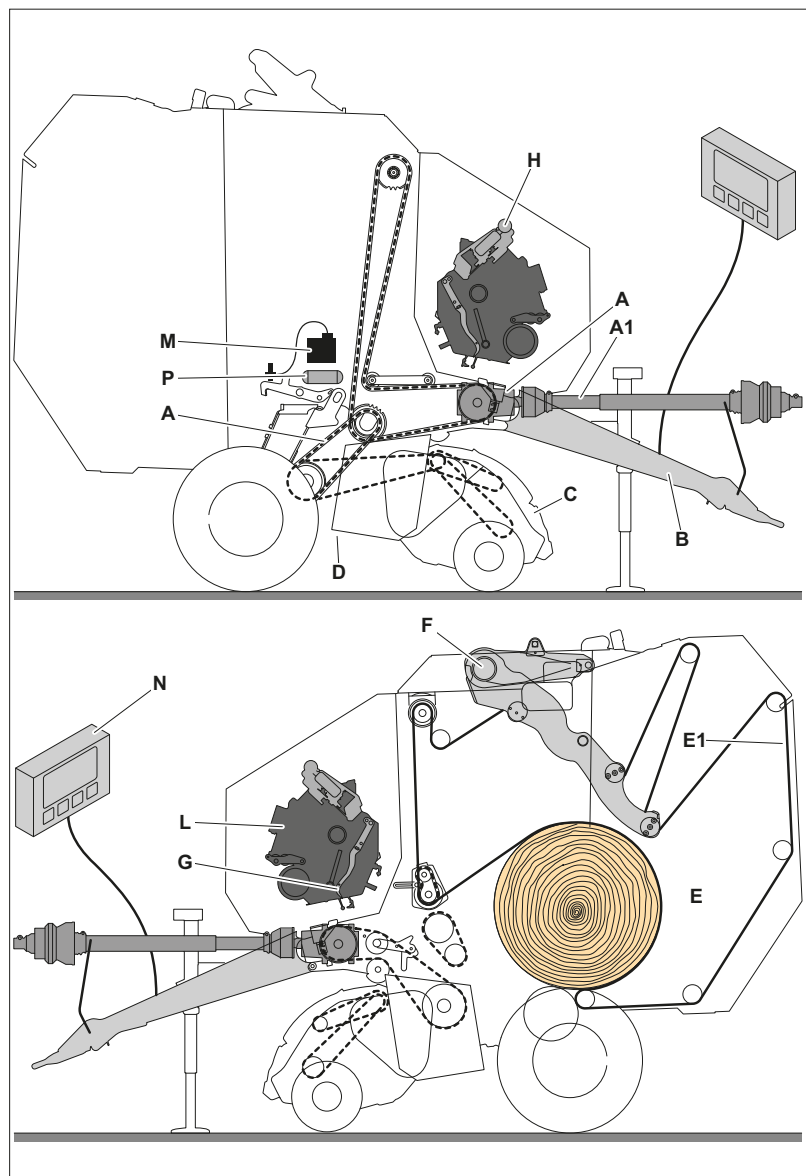

- A) **Transmission unit:** this unit is of a mechanical type (with reducer and PTO shaft) and conveys motion to the machine's main operating units by means of a kinematic mechanism made up of pinions and chains.
- A1) **PTO shaft:** the shaft supplied along with the machine is of a constant velocity type and can be equipped with a shear bolt. The PTO shaft supplied along with the machine complies with the provisions of the relevant directives and standards in force.
- B) **Drawbar:** connects the machine to the tractor, and its height can be adjusted to adapt to the tractor's towing hitch.
- C) **Pick-up unit:** picks up the windrow product and conveys it into the feeding unit. Depending upon the conformation of the ground and the width of the windrow, the machine can be equipped with various types of pick-up units. ⁽¹⁾
- D) **Product feeding unit:** transfers the product into the baling chamber. Depending upon the type of product to be picked up, the machine can be equipped with various types of feeding units. ⁽¹⁾

General description of the machine

- E) **Baling chamber:** this unit is of a “variable volume” type and creates the bale using belts (**E1**) and rollers.
- F) **Tensioning unit:** tightens the belts (**E1**) of the baling chamber (**E**).
- G) **Net binder group:** quickly binds the bale up to the edges, so that the bale becomes solid and compact. ⁽¹⁾
- H) **Twine binding unit:** binds the bale with spirals of twine so that the bale becomes solid and compact. ⁽¹⁾
- L) **Net or twine insertion device:** inserts the binding element into the baling chamber.
- M) **Centralized lubrication system:** automatically lubricates the transmission chains.
- N) **Electronic control system:** used to display and set the production parameters. ⁽¹⁾
- P) **Document compartment:** for the keys and the machine's user and maintenance manual.

⁽¹⁾ To find out more about the features and functionalities of the operating group installed on the machine, please refer to the relevant chapter.

Electronic control panel

- The electronic control system on your baler has been carefully designed to monitor the production of the bale as it is being formed.
- Once the bale has reached the desired diameter, it then controls the subsequent binding process. Furthermore, various machine settings can be adjusted from the comfort of the tractor's seat.
- For correct and reliable operation, it is important that an adequate 12 volt power supply be provided, and that the “FOCUS” terminal be correctly installed so that it can be easily and clearly seen by the operator at all times.
- This baler must only be operated by an operator who is adequately skilled to drive and use the machine under safe conditions.

Operating cycle

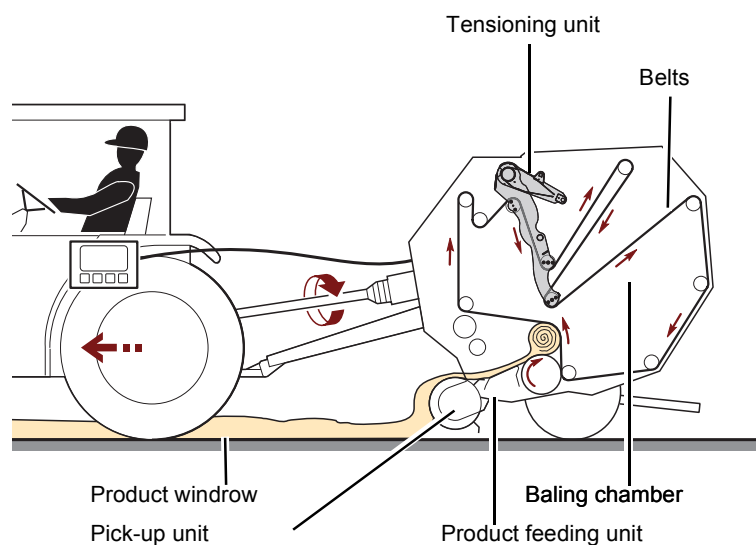

- The machine advances along the windrow; the pick-up unit collects the product and transports it into the feeding unit. The feeding unit conveys the product into the baling chamber.

General description of the machine

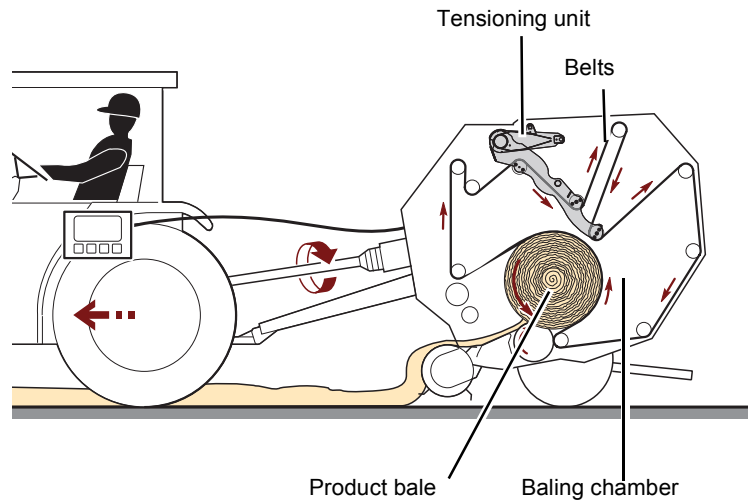

- ▶ The baling process begins inside the baling chamber thanks to the operation of the belts. The tensioning unit keeps the belts tightened in order to constantly adapt to the bale's changing diameter.

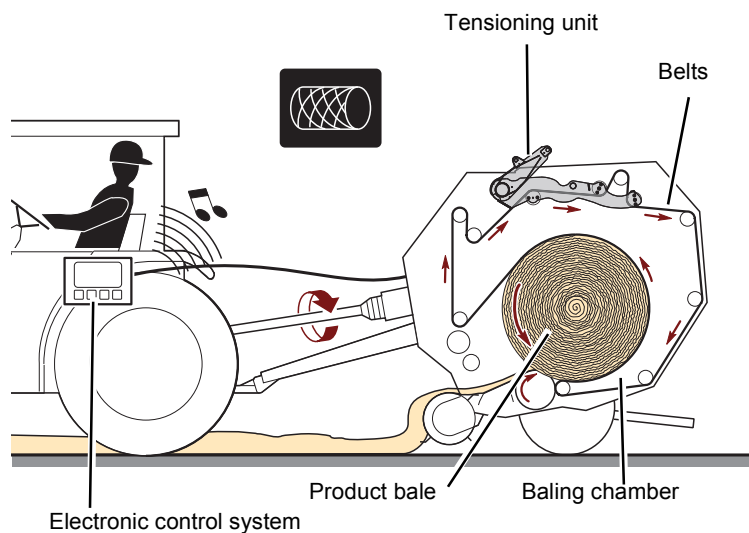

- ▶ When the bale achieves the set diameter, the electronic control system emits an acoustic signal to warn the operator that it is necessary to interrupt the tractor's forward movement. According to the selected type of binding (twine, net or mixed) and the operating mode set on the electronic control system (manual or automatic), the binding unit starts the bale binding operation.

General description of the machine

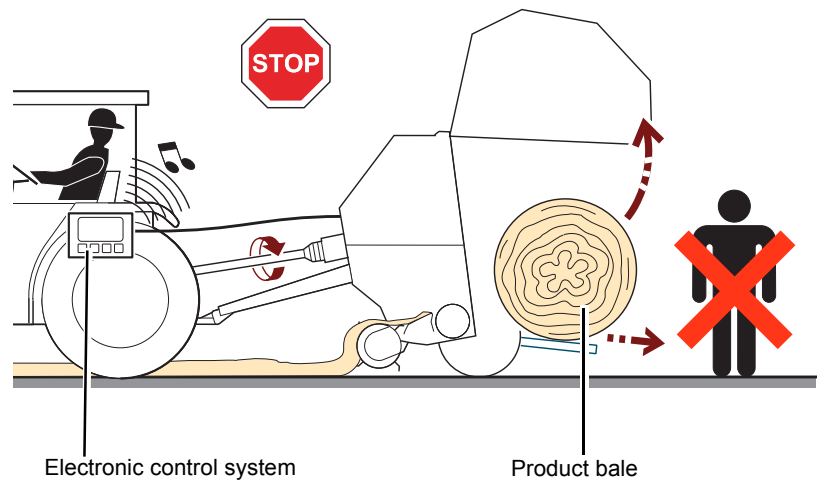

- ▶ Once the binding process has been completed, the electronic control system emits another acoustic signal to advise the operator that the tailgate can be opened to unload the bale. If the machine is equipped with a bale kicker, the work activities can be resumed with no need to perform any additional maneuvers.

If the machine is not equipped with a bale kicker, the operator must move the machine backwards by about 4-5 m (13"-16"), and then unload the bale. At the end of the unloading operation, in order to prevent the tailgate from bumping against the bale during the closing operation, the operator must move the machine back to the start of the windrow; the work can be resumed by carrying out the required procedures.

WARNING

In the case of terrain with a slope that poses a risk of sudden and uncontrolled bale movements, unload the bale perpendicular to the slope. Use this precaution especially when the machine is equipped with a bale kicker. If it is not possible to unload the bale in a safe manner, transfer the machine to a suitable area, and then unload the bale.

General description of the machine

Equipment

The following equipment is supplied along with the machine.

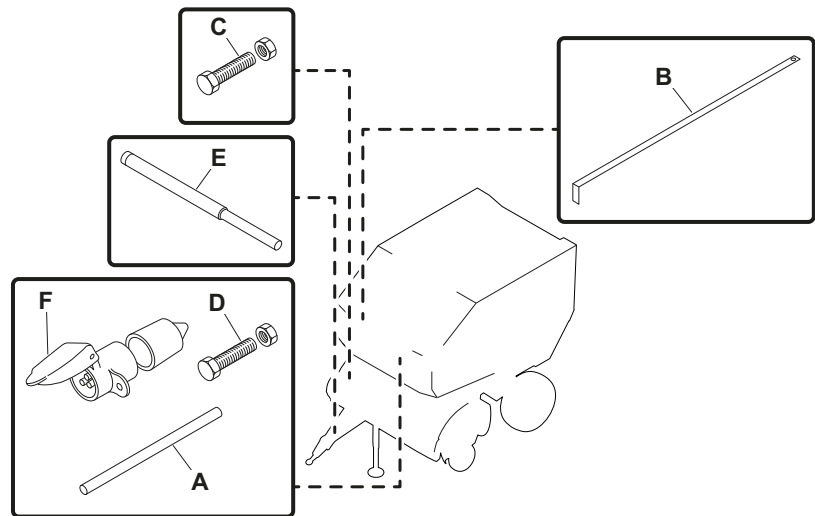

- A) **Bar:** used during the repairs of the rollers in the baling chamber.
- B) **Bar:** used to insert the twine into the twine guide arms.
- C) **Pick-up unit shear bolt:** in the case of a product blockage, this bolt shears to prevent damage to the machine's assemblies or components (Only for the narrow or wide pick-up unit).
- D) **PTO shaft shear bolt** (if present): in the case of a blockage, this bolt shears in order to prevent damaging the PTO shaft or the machine's components.



NOTICE

ONLY replace sheared "shear bolts" with original spare parts that comply with the requirements.

- E) **Pin:** used to re-align the sprockets after the shear bolt has broken on the pick-up unit.
- F) **Power outlet:** this 3-pin outlet must be installed on the tractor if it is not equipped with one.

General description of the machine

Accessories available upon request

The machine can be equipped with certain optional accessories, either at time of order or subsequently.

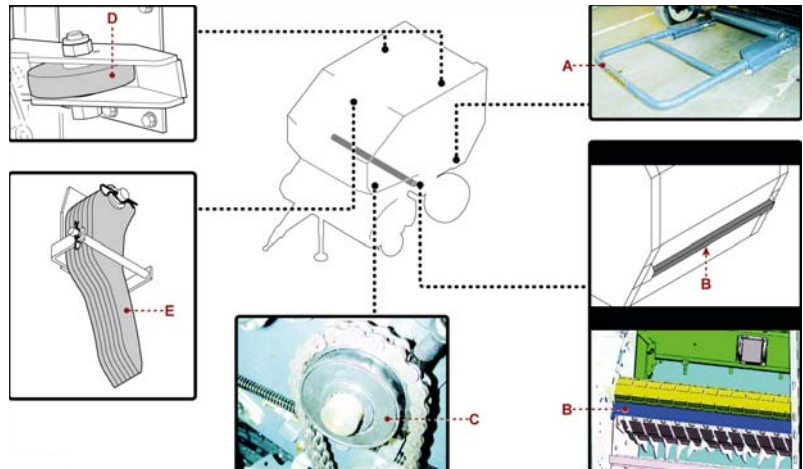

CAUTION

Any accessories requested after the machine's purchase must be installed by personnel with specific technical skills, at a workshop that is properly equipped and authorized by the manufacturer.

The subject who has installed the accessory must issue a document certifying that its installation has been carried out at a workshop authorized by the manufacturer.

NOTICE

The listed accessories may **ONLY** be installed on the machine models indicated by the manufacturer. **DO NOT** attempt to tamper with the accessories in order to adapt them to machine models for which they are not intended and/or to obtain performance levels other than those permitted.

- A) Bale kicker:** used to move the bale away from the machine during the unloading operation. In this manner, the tailgate can be closed with no need to carry out any additional maneuvers (forward and reverse) in order to resume the pick-up operations from the point at which they were interrupted.

DANGER

In the case of terrain with a slope that poses a risk of sudden and uncontrolled bale movements, unload the bale perpendicular to the slope. Use this precaution especially when the machine is equipped with a bale kicker. If it is not possible to unload the bale in a safe manner, transfer the machine to a suitable area, and then unload the bale.

- B) Short crop plate:** used to compress dry, short and brittle products (for example, straw). It is particularly suitable when the pick-up is performed in the hottest hours and/or seasons (in some models,

General description of the machine

device is supplied as standard equipment).



NOTICE

Do not use the device to compress damp products. Always remove the short crop plate before compressing damp products.

- C) **Roller transmission clutch (R2-R3):** controls overloads on the transmission chain.
- D) **Guide wheel kit:** used to facilitate the closing of the tailgate on uneven terrain and steep slopes.
- E) **Spare plate kit:** must be installed in place of the feeding device's cutters in order to obtain entirely or partially cut products.
 - **“Brake” kit:** a pneumatically or hydraulically controlled kit that improves the machine's braking power.
 - **PTO shaft with pawl-type torque limiter:** this constant velocity unit disengages the movement in the event of a machine jam and/or blockage.
 - **Chain lubricating system:** used to ensure the automatic lubrication of the chains with an independent lubricant tank controlled by a timer.
 - **Central lubrication system roller bearings:** used to allow the simultaneous lubrication of the baling chamber's roller bearings.

Hydraulic devices

The list only contains the descriptions and functionalities of certain hydraulic devices.

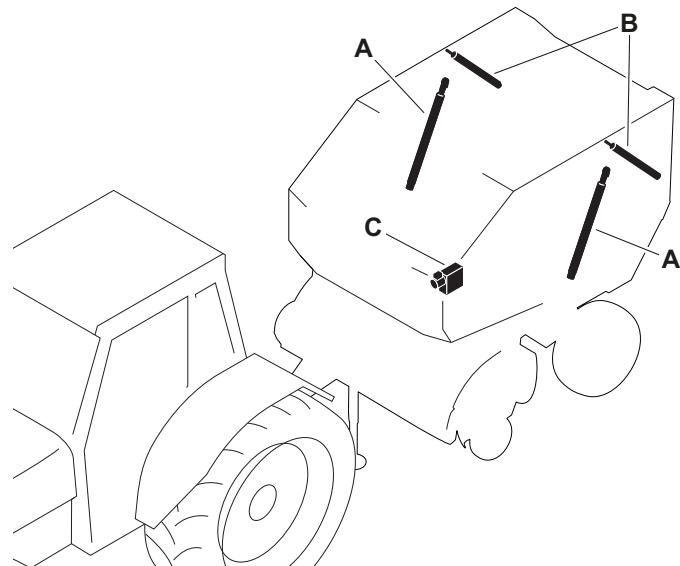

- A) **Hydraulic cylinder:** of a single acting type, used to open and close the tailgate.
- B) **Hydraulic cylinder:** of a double acting type, used to drive the belt tensioner in order to create a bale with the density set using the electronic control system or the manual valve, depending on the model.
- C) **Maximum pressure valve:** checks the maximum operating pressure of the belt tensioner, and is adjusted either manually or else using the electronic control system.
- D) **Hydraulic cylinder:** of a double acting type, used to raise the

General description of the machine

pick-up unit.

Electronic and electrical devices

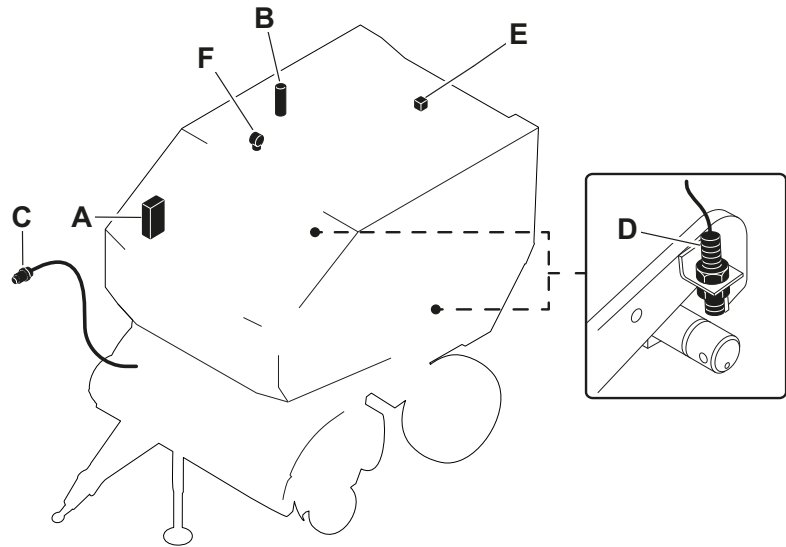

- A) **Secondary electronic control unit (ECU):** manages the functioning processes of all the mechanisms installed on the machine (feeding unit, binding unit, etc.)
- B) **Potentiometer:** detects the bale diameter obtained.
- C) **Plug:** for connecting the binding unit's electrical system to the tractor.
- D) **Sensor:** detects the position of the tailgate's closure hooks.
- E) **Potentiometer:** detects the excessive product accumulation difference between the right, left and center of the bale being formed. The value is indicated on the electronic control system's display so that the operator can modify the tractor's trajectory.
- F) **Potentiometer:** measures the diameter reached by the bale.

General description of the machine

Page intentionally left blank

Technical data BV 5160 R

Description	Unit of measurement	Model		
		BV 5160 RT	BV 5160 RN	BV 5160 RNT
Machine characteristics				
Total length of the machine	mm (in)	4480 (176")	4480 (176")	4480 (176")
Total width of the machine	mm (in)	2520 (99")	2520 (99")	2520 (99")
Total height of the machine	mm (in)	2750 (108")	2750 (108")	2750 (108")
Weight	kg (lb)	3000 (6614)	3000 (6614)	3000 (6614)
Maximum vertical stress on the eyelet	kg (lb)	See identification plate		
Bale hourly output	n.	18-35	18-35	18-35
Tire characteristics				
Dimensions of the machine tires		15.0/55-17"	15.0/55-17"	15.0/55-17"
Inflation pressure	bar (psi)	2.5 (36)	2.5 (36)	2.5 (36)
Dimensions of machine tires (optional)		a - 19.0/45-17" b - 550/45-22.5"	a - 19.0/45-17" b - 550/45-22.5"	a - 19.0/45-17" b - 550/45-22.5"
Inflation pressure	bar (psi)	a - 2.5 (36) b - 1.5 (36)	a - 2.5 (36) b - 1.5 (36)	a - 2.5 (36) b - 1.5 (36)
Dimensions of pick-up unit wheel tires		16x6.50-8 6 PR	16x6.50-8 6 PR	16x6.50-8 6 PR
Inflation pressure	bar (psi)	1.5 (22)	1.5 (22)	1.5 (22)
Tightening torque for machine wheel columns	Nm (lbs*ft)	310 (228)	310 (228)	310 (228)
Lubrication system				
Tank capacity	lt (pints)	2 (4.2)		
Lubrication type		Automatic lubrication		
Baling chamber characteristics				
Rollers	n.	3	3	3
Belts	n.	5	5	5
Feeding unit				
Type		Rotor intake	Rotor intake	Rotor intake
Net binder group				
Type		Electronic binding unit (Optional)	Electronic binding unit	Electronic binding unit
Twine binding unit				

Technical data

Description	Unit of measurement	Model		
		BV 5160 RT	BV 5160 RN	BV 5160 RNT
Type		Electronic binding unit	Electronic binding unit (Optional)	Electronic binding unit
Twine quantity	n.	2	2	2
Coil brake characteristics				
Maximum diameter of the reel	mm (in)		320 (12.5")	
Maximum width of the reel	mm (in)		1300 (51")	
Net type	gr/m (lb/ft)		14-18 (0.010-0.013)	
Twine reel characteristics				
Maximum diameter of the reel	mm (in)		250 (10")	
Maximum height of the reel	mm (in)		240 (9.5")	
Twine type (synthetic)	m/kg (ft/lb)		500-1000 (750-1500)	
Twine type (natural)	m/kg (ft/lb)		200-400 (300-600)	
Bale characteristics				
Diameter	mm (in)		600-1650 (24"-65")	
Width	mm (in)		1200 (47")	
Max volume	m ³ (cuft)		2.5 (88)	
Pick-up unit				
Type		"Extra-wide" pick-up unit	"Extra-wide" pick-up unit	"Extra-wide" pick-up unit
Maximum pick-up width	mm (in)	2200 (87") 2060 (81") Standard DIN	2200 (87") 2060 (81") Standard DIN	2200 (87") 2060 (81") Standard DIN
Tines bars	n.	5	5	5
Pick-up tines (for each bar)	n.	32	32	32
Distance between pick-up tines	mm (in)	60 (2" 3/8)	60 (2" 3/8)	60 (2" 3/8)
Torque limiter		-	-	-
Lubrication type		Lubrication from centralized system (Optional)		
Tractor requirements				
Minimum power to the PTO	HP -kW		60 - 45	
Recommended power to the PTO	HP - kW		70 - 52	
PTO rotation rate	rpm		540	
Splined PTO shaft profile			1"3/8 z=6	
Tow bar			Rotating, with "U" hook	

Technical data

Description	Unit of measurement	Model		
		BV 5160 RT	BV 5160 RN	BV 5160 RNT
Diameter of the tractor's towing coupling pin	mm (in)	35 (1"3/8) - 40 (1"1/2") - 50 (2")		
Hydraulic system		1 single-acting control valve + 1 double-acting control valve with floating position		
Quick-release couplings for hydraulic system		ISO 7241-1 series "A", size 081/2; max pressure 180 bar (2610 psi)		
Electrical system		1 electric socket 3-pin 12V 1 electric socket 7-pin 12V		
Noise level				
Sound level detected at driver's seat	db(A)	89 (Utilize ear protection muffs)		
PTO shaft				
Shear bolt		-	-	-
Torque limiter	Nm (lbs*ft)	2000 (1475)	2000 (1475)	2000 (1475)

Technical data

Technical data BV 5160 SC

Description	Unit of measurement	Model			
		BV 5160 SC14N	BV 5160 SC14NT	BV 5160 SC25N	BV 5160 SC25ALN
Machine characteristics					
Total length of the machine	mm (in)	4480 (176")	4480 (176")	4480 (176")	4480 (176")
Total width of the machine	mm (in)	2520 (99")	2520 (99")	2520 (99")	2520 (99")
Total height of the machine	mm (in)	2750 (108")	2750 (108")	2750 (108")	2750 (108")
Weight	kg (lb)	3200 (7055)	3260 (7187)	3550 (7826)	3600 (7937)
Maximum vertical stress on the eyelet	kg (lb)	See identification plate			
Bale hourly output	n.	18-35	18-35	18-35	18-35
Tire characteristics					
Dimensions of the machine tires		15.0/55-17"	15.0/55-17"	15.0/55-17"	15.0/55-17"
Inflation pressure	bar (psi)	2.5 (36)	2.5 (36)	2.5 (36)	2.5 (36)
Dimensions of machine tires (optional)		a - 19.0/45-17" b - 550/45-22.5"	a - 19.0/45-17" b - 550/45-22.5"	a - 19.0/45-17" b - 550/45-22.5"	a - 19.0/45-17" b - 550/45-22.5"
Inflation pressure	bar (psi)	a - 2.5 (36) b - 1.5 (22)	a - 2.5 (36) b - 1.5 (22)	a - 2.5 (36) b - 1.5 (22)	a - 2.5 (36) b - 1.5 (22)
Dimensions of pick-up unit wheel tires		16x6.50-8 6 PR	16x6.50-8 6 PR	16x6.50-8 6 PR	16x6.50-8 6 PR
Inflation pressure	bar (psi)	1.5 (22)	1.5 (22)	1.5 (22)	1.5 (22)
Tightening torque for machine wheel columns	Nm (lbs*ft)	310 (228)	310 (228)	310 (228)	310 (228)
Lubrication system					
Tank capacity	lt (pints)	2 (4.2)			
Lubrication type		Automatic lubrication			
Baling chamber characteristics					
Rollers	n.	3	3	3	3
Belts	n.	5	5	5	5
Feeding unit					
Type		14 knife Supercut	14 knife Supercut	25 knife Supercut	25 knife Supercut
Net binder group					
Type		Electronic binding unit	Electronic binding unit	Electronic binding unit	Electronic binding unit

Technical data

Description	Unit of measurement	Model			
		BV 5160 SC14N	BV 5160 SC14NT	BV 5160 SC25N	BV 5160 SC25ALN
Twine binding unit					
Type		Electronic binding unit (Optional)	Electronic binding unit	Electronic binding unit (Optional)	Electronic binding unit (Optional)
Twine quantity	n.	2	2	2	2
Coil brake characteristics					
Maximum diameter of the reel	mm (in)	320 (12.5")			
Maximum width of the reel	mm (in)	1300 (51")			
Net type	gr/m (lb/ft)	14-18 (0.010-0.013)			
Twine reel characteristics					
Maximum diameter of the reel	mm (in)	250 (10")			
Maximum height of the reel	mm (in)	240 (9.5")			
Twine type (synthetic)	m/kg (ft/lb)	500-1000 (750-1500)			
Twine type (natural)	m/kg (ft/lb)	200-400 (300-600)			
Bale characteristics					
Diameter	mm (in)	600-1650 (24"-65")			
Width	mm (in)	1200 (47")			
Max volume	m ³ (cuft)	2.5 (88)			
Pick-up unit					
Type		"Extra-wide" pick-up unit	"Extra-wide" pick-up unit	"Extra-wide" pick-up unit	"Extra-wide" pick-up unit
Maximum pick-up width	mm (in)	2200 (87") 2060 (81") Standard DIN	2200 (87") 2060 (81") Standard DIN	2200 (87") 2060 (81") Standard DIN	2200 (87") 2060 (81") Standard DIN
Tines bars	n.	5	5	5	5
Pick-up tines (for each bar)	n.	32	32	32	32
Distance between pick-up tines	mm (in)	60 (2" 3/8)	60 (2" 3/8)	60 (2" 3/8)	60 (2" 3/8)
Torque limiter		-			
Lubrication type		Lubrication from centralized system			
Tractor requirements					
Minimum power to the PTO	HP -kW	75 - 56		90 - 66	
Recommended power to the PTO	HP - kW	85 - 64		110 - 82	

Technical data

Description	Unit of measurement	Model			
		BV 5160 SC14N	BV 5160 SC14NT	BV 5160 SC25N	BV 5160 SC25ALN
PTO rotation rate	rpm	540			
Splined PTO shaft profile		1"3/8 z=6			
Tow bar		Rotating, with "U" hook			
Diameter of the tractor's towing coupling pin	mm (in)	35 (1"3/8) - 40 (1"1/2") - 50 (2")			
Hydraulic system		1 single-acting control valve + 1 double-acting control valve with floating position	1 double action control valve + 1 double action control valve with floating position		
Quick-release couplings for hydraulic system		ISO 7241-1 series "A", size 081/2; max pressure 180 bar (2610 psi)			
Electrical system		1 electric socket 3-pin 12V 1 electric socket 7-pin 12V			
Noise level					
Sound level detected at driver's seat	db(A)	89 (Utilize ear protection muffs)			
PTO shaft					
Shear bolt		-	-	-	-
Torque limiter	Nm (lbs*ft)	2000 (1475)	2000 (1475)	2200 (1623)	2200 (1623)

Technical data BV 5200 R

Description	Unit of measurement	Model		
		BV 5200 RT	BV 5200 RN	BV 5200 RNT
Machine characteristics				
Total length of the machine	mm (in)	4750 (187")	4750 (187")	4750 (187")
Total width of the machine	mm (in)	2520 (99")	2520 (99")	2520 (99")
Total height of the machine	mm (in)	2820 (111")	2820 (111")	2820 (111")
Weight	kg (lb)	3300 (7275)	3300 (7275)	3360 (7408)
Maximum vertical stress on the eyelet	kg (lb)	See identification plate		
Bale hourly output	n.	18-35	18-35	18-35
Tire characteristics				
Dimensions of the machine tires		15.0/55-17"	15.0/55-17"	15.0/55-17"
Inflation pressure	bar (psi)	2.5 (36)	2.5 (36)	2.5 (36)
Dimensions of machine tires (optional)		a - 19.0/45-17" b - 550/45-22.5"	a - 19.0/45-17" b - 550/45-22.5"	a - 19.0/45-17" b - 550/45-22.5"
Inflation pressure	bar (psi)	a - 2.5 (36) b - 1.5 (36)	a - 2.5 (36) b - 1.5 (36)	a - 2.5 (36) b - 1.5 (36)
Dimensions of pick-up unit wheel tires		16x6.50-8 6 PR	16x6.50-8 6 PR	16x6.50-8 6 PR
Inflation pressure	bar (psi)	1.5 (22)	1.5 (22)	1.5 (22)
Tightening torque for machine wheel columns	Nm (lbs*ft)	310 (228)	310 (228)	310 (228)
Lubrication system				
Tank capacity	lt (pints)	2 (4.2)		
Lubrication type		Automatic lubrication		
Baling chamber characteristics				
Rollers	n.	3	3	3
Belts	n.	5	5	5
Feeding unit				
Type		Rotor intake	Rotor intake	Rotor intake
Net binder group				
Type		Electronic binding unit (Optional)	Electronic binding unit	Electronic binding unit
Twine binding unit				

Technical data

Description	Unit of measurement	Model		
		BV 5200 RT	BV 5200 RN	BV 5200 RNT
Type		Electronic binding unit	Electronic binding unit (Optional)	Electronic binding unit
Twine quantity	n.	2	2	2
Coil brake characteristics				
Maximum diameter of the reel	mm (in)		320 (12.5")	
Maximum width of the reel	mm (in)		1300 (51")	
Net type	gr/m (lb/ft)		14-18 (0.010-0.013)	
Twine reel characteristics				
Maximum diameter of the reel	mm (in)		250 (10")	
Maximum height of the reel	mm (in)		240 (9.5")	
Twine type (synthetic)	m/kg (ft/lb)		500-1000 (750-1500)	
Twine type (natural)	m/kg (ft/lb)		200-400 (300-600)	
Bale characteristics				
Diameter	mm (in)		600-2000 (24"-79")	
Width	mm (in)		1200 (47")	
Max volume	m ³ (cuft)		3.7 (131)	
Pick-up unit				
Type		"Extra-wide" pick-up unit	"Extra-wide" pick-up unit	"Extra-wide" pick-up unit
Maximum pick-up width	mm (in)	2200 (87") 2060 (81") Standard DIN	2200 (87") 2060 (81") Standard DIN	2200 (87") 2060 (81") Standard DIN
Tines bars	n.	5	5	5
Pick-up tines (for each bar)	n.	32	32	32
Distance between pick-up tines	mm (in)	60 (2" 3/8)	60 (2" 3/8)	60 (2" 3/8)
Torque limiter		-	-	-
Lubrication type		Lubrication from centralized system (Optional)		
Tractor requirements				
Minimum power to the PTO	HP -kW		70 - 52	
Recommended power to the PTO	HP - kW		75 - 56	
PTO rotation rate	rpm		540	
Splined PTO shaft profile			1"3/8 z=6	
Tow bar			Rotating, with "U" hook	

Technical data

Description	Unit of measurement	Model		
		BV 5200 RT	BV 5200 RN	BV 5200 RNT
Diameter of the tractor's towing coupling pin	mm (in)	35 (1"3/8) - 40 (1"1/2") - 50 (2")		
Hydraulic system		1 single-acting control valve + 1 double-acting control valve with floating position		
Quick-release couplings for hydraulic system		ISO 7241-1 series "A", size 081/2; max pressure 180 bar (2610 psi)		
Electrical system		1 electric socket 3-pin 12V 1 electric socket 7-pin 12V		
Noise level				
Sound level detected at driver's seat	db(A)	89 (Utilize ear protection muffs)		
PTO shaft				
Shear bolt		-	-	-
Torque limiter	Nm (lbs*ft)	2000 (1475)	2000 (1475)	2000 (1475)

Technical data

Technical data BV 5200 SC

Description	Unit of measurement	Model			
		BV 5200 SC14N	BV 5200 SC14NT	BV 5200 SC25N	BV 5200 SC25ALN
Machine characteristics					
Total length of the machine	mm (in)	4750 (187")	4750 (187")	4750 (187")	4750 (187")
Total width of the machine	mm (in)	2520 (99")	2520 (99")	2520 (99")	2520 (99")
Total height of the machine	mm (in)	2820 (111")	2820 (111")	2820 (111")	2820 (111")
Weight	kg (lb)	3500 (7716)	3560 (7849)	3850 (8488)	3900 (8598)
Maximum vertical stress on the eyelet	kg (lb)	See identification plate			
Bale hourly output	n.	18-35	18-35	18-35	18-35
Tire characteristics					
Dimensions of the machine tires		15.0/55-17"	15.0/55-17"	15.0/55-17"	15.0/55-17"
Inflation pressure	bar (psi)	2.5 (36)	2.5 (36)	2.5 (36)	2.5 (36)
Dimensions of machine tires (optional)		a - 19.0/45-17" b - 550/45-22.5"	a - 19.0/45-17" b - 550/45-22.5"	a - 19.0/45-17" b - 550/45-22.5"	a - 19.0/45-17" b - 550/45-22.5"
Inflation pressure	bar (psi)	a - 2.5 (36) b - 1.5 (22)	a - 2.5 (36) b - 1.5 (22)	a - 2.5 (36) b - 1.5 (22)	a - 2.5 (36) b - 1.5 (22)
Dimensions of pick-up unit wheel tires		16x6.50-8 6 PR	16x6.50-8 6 PR	16x6.50-8 6 PR	16x6.50-8 6 PR
Inflation pressure	bar (psi)	1.5 (22)	1.5 (22)	1.5 (22)	1.5 (22)
Tightening torque for machine wheel columns	Nm (lbs*ft)	310 (228)	310 (228)	310 (228)	310 (228)
Lubrication system					
Tank capacity	lt (pints)	2 (4.2)			
Lubrication type		Automatic lubrication			
Baling chamber characteristics					
Rollers	n.	3	3	3	3
Belts	n.	5	5	5	5
Feeding unit					
Type		14 knife Supercut	14 knife Supercut	25 knife Supercut	25 knife Supercut
Net binder group					
Type		Electronic binding unit	Electronic binding unit	Electronic binding unit	Electronic binding unit

Technical data

Description	Unit of measurement	Model			
		BV 5200 SC14N	BV 5200 SC14NT	BV 5200 SC25N	BV 5200 SC25ALN
Twine binding unit					
Type		Electronic binding unit (Optional)	Electronic binding unit	Electronic binding unit (Optional)	Electronic binding unit (Optional)
Twine quantity	n.	2	2	2	2
Coil brake characteristics					
Maximum diameter of the reel	mm (in)	320 (12.5")			
Maximum width of the reel	mm (in)	1300 (51")			
Net type	gr/m (lb/ft)	14-18 (0.010-0.013)			
Twine reel characteristics					
Maximum diameter of the reel	mm (in)	250 (10")			
Maximum height of the reel	mm (in)	240 (9.5")			
Twine type (synthetic)	m/kg (ft/lb)	500-1000 (750-1500)			
Twine type (natural)	m/kg (ft/lb)	200-400 (300-600)			
Bale characteristics					
Diameter	mm (in)	600-2000 (24"-79")			
Width	mm (in)	1200 (47")			
Max volume	m ³ (cuft)	3.7 (131)			
Pick-up unit					
Type		"Extra-wide" pick-up unit	"Extra-wide" pick-up unit	"Extra-wide" pick-up unit	"Extra-wide" pick-up unit
Maximum pick-up width	mm (in)	2200 (87") 2060 (81") Standard DIN	2200 (87") 2060 (81") Standard DIN	2200 (87") 2060 (81") Standard DIN	2200 (87") 2060 (81") Standard DIN
Tines bars	n.	5	5	5	5
Pick-up tines (for each bar)	n.	32	32	32	32
Distance between pick-up tines	mm (in)	60 (2" 3/8)	60 (2" 3/8)	60 (2" 3/8)	60 (2" 3/8)
Torque limiter		-			
Lubrication type		Lubrication from centralized system			
Tractor requirements					
Minimum power to the PTO	HP -kW	80 - 60		95 - 72	
Recommended power to the PTO	HP - kW	90 - 68		115 - 86	

Technical data

Description	Unit of measurement	Model			
		BV 5200 SC14N	BV 5200 SC14NT	BV 5200 SC25N	BV 5200 SC25ALN
PTO rotation rate	rpm	540			
Splined PTO shaft profile		1"3/8 z=6			
Tow bar		Rotating, with "U" hook			
Diameter of the tractor's towing coupling pin	mm (in)	35 (1"3/8) - 40 (1"1/2") - 50 (2")			
Hydraulic system		1 single-acting control valve + 1 double-acting control valve with floating position		1 double action control valve + 1 double action control valve with floating position	
Quick-release couplings for hydraulic system		ISO 7241-1 series "A", size 081/2; max pressure 180 bar (2610 psi)			
Electrical system		1 electric socket 3-pin 12V 1 electric socket 7-pin 12V			
Noise level					
Sound level detected at driver's seat	db(A)	89 (Utilize ear protection muffs)			
PTO shaft					
Shear bolt		-	-	-	-
Torque limiter	Nm (lbs*ft)	2000 (1475)	2000 (1475)	2200 (1623)	2200 (1623)

Technical data of the electronic control panel

Description	Unit of measurement	Value
Display		
Type		LCD monochrome display
Size	mm (inch)	-
Display resolution	pixels	320 x 240
Data transmission		
Serial type		RS232 DB9
CAN type		CANBUS IN/OUT
Technical specifications		
Size	mm (inch)	250x160x70 (9.8"x6.3"x2.8")
Weight	kg (lb)	0.95 (2.09)
Supply voltage	V	9-14 Vdc
Absorbed power	W	-
Protection rating (front)		IP65
Working temperature	°C (F)	-10 / +60 (14 / 140)
Humidity (without condensate)		10-90%

Page intentionally left blank

Handling and loading instructions

CAUTION

Perform the handling and loading operations in accordance with the information supplied by the manufacturer, which can be found on the machine and in the user instructions. If necessary, the individuals authorized to perform these operations must prepare a “safety plan” in order to protect those who are directly involved.

Packing and unpacking

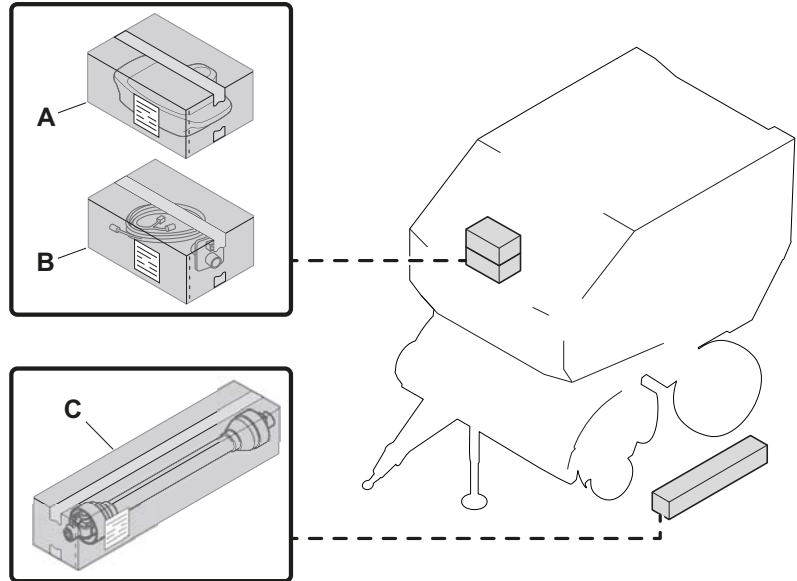

Depending on the destination, the loading and transport operations can be carried out using different means.

With the exception of certain components, the machine is shipped without packaging.

- A) **Electronic control system:** this unit is packed inside a box, which is placed inside the reel support's container (twine).
- B) **ISObus cable and electrical connector** (if applicable).
- C) **PTO shaft:** this unit is packed inside a box, which is fastened to a part of the machine.

NOTICE

Upon receipt, check that the machine and its components are not damaged. In the case of damage or missing parts, call the manufacturer or your local dealer to agree upon the procedures to be adopted.

Preliminary operations

Loading and unloading

The machine can be loaded onto the means of transport in different ways.

- Loading the machine using the tractor.
- Loading the machine using a hook-type lifting device.

CAUTION

The personnel in charge of loading, unloading and handling the machine must have the skills and competences necessary for the specific sector, and must be fully qualified to use the relative equipment.

Loading the machine using the tractor

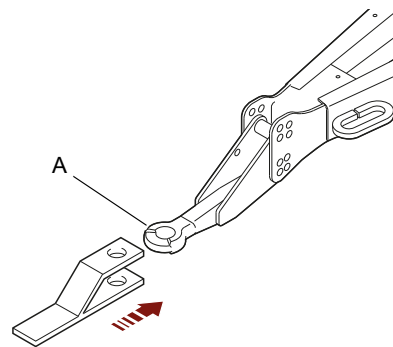
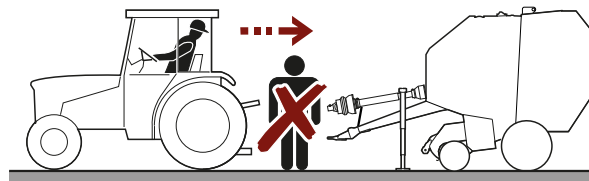

- ▶ Move the tractor backward until you are close, and align the towing hitch with the eyelet (A).
- ▶ Adapt the height of the drawbar to the height of the towing hitch (See. "How to set the height of the drawbar")

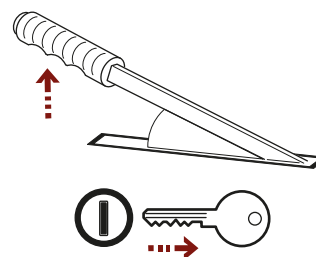

- ▶ Turn off the engine, engage the parking brake, and remove the ignition key.

Preliminary operations

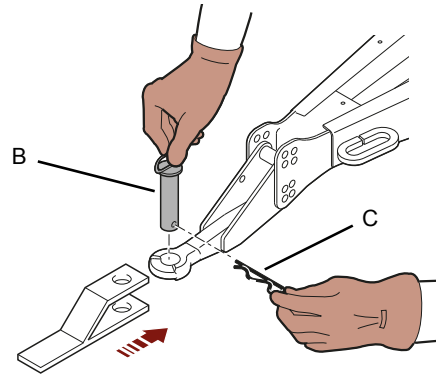

- ▶ Insert the hitch pin (B) and its locking pin (C).

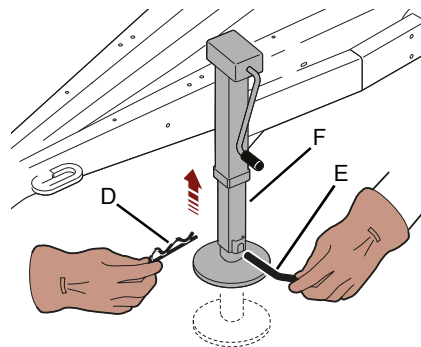

- ▶ Remove the locking pin (D) and the hitch pin (E), lift the leg (F) and then fasten it again.

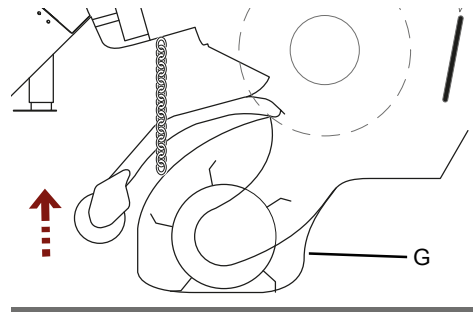

- ▶ Lift the pick-up unit (G), and then lock it in its "lifted" position using the specific safety lock valve.

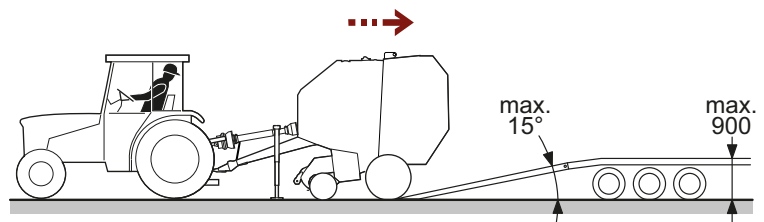

- ▶ Load the machine onto the means of transport, as shown in the figure.
Use ramps with a suitable slope and load-bearing capacity.
- ▶ Remove the locking pin (D) and the hitch pin (E), lower the leg (F) and then reinsert the hitch pin complete with the retaining clip.
- ▶ Remove the locking pin (C) and the hitch pin (B) to disengage the tractor from the machine.

Preliminary operations

CAUTION

DO NOT push the pin out from below using your finger.

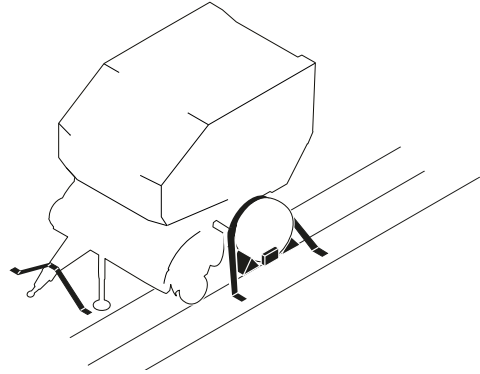

- ▶ Properly secure the machine to the means of transport using cables, safety straps, and chocks, as required by the local transport regulations.
- ▶ Make sure the size of the load does not exceed the maximum overall dimensions permitted. If necessary, prepare suitable signs.

Loading the machine using a hook-type lifting device

WARNING

Slowly lift the machine, and handle it with extreme care in order to prevent dangerous swinging motions.

- ▶ Visually check that the tailgate's locking hooks are completely and correctly closed.

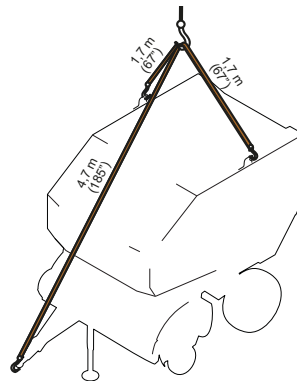

- ▶ Prearrange for a hook-type lifting device with a suitable lifting capacity, and connect it to the machine using appropriate chains or lifting cables.

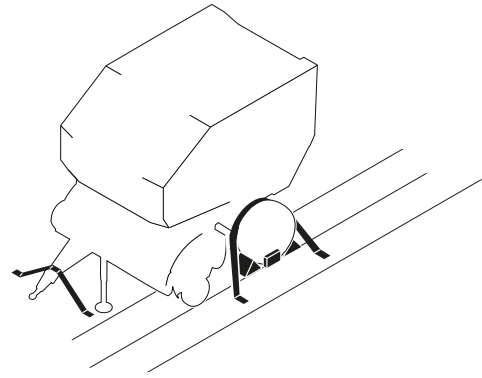

- ▶ Properly secure the machine to the means of transport using cables, safety straps, and chocks, as required by the local transport regulations.

Preliminary checks and inspections

Upon receiving the machine, perform a thorough inspection in order to make sure that there are no damaged parts or defects. Also verify the receipt of all the components necessary for its use, including both standard and optional equipment.



NOTICE

If any damaged parts, defects, or deficiencies are encountered in relation to the machine, whether due to transport or other causes, contact the manufacturer immediately in order to have the issues immediately resolved.



WARNING

Never use the machine if it does not appear to be fully consistent with the usage and safety characteristics, as the minimum necessary safety requirements could be compromised.

Machine-tractor combination

- Upon receiving the machine, check the category and characteristics of the tractor to which it is to be coupled in order to ensure its stability and proper functionality.
- After having verified the characteristics of the tractor, it is necessary to adapt the height of the drawbar and the length of the PTO shaft (See “Setting the height of the drawbar” - “Setting the length of the PTO shaft”).
- The length of the PTO shaft supplied along with the machine is capable of satisfying any type of machine-tractor combination. The operator is responsible for cutting the PTO shaft correctly.



CAUTION

The PTO shaft must be long enough so that it does not jam at its minimum extension, or slip out at its maximum extension.

Preliminary operations

CAUTION

The PTO shaft must be equipped with a constant velocity joint. Consult the manufacturer's manual for further details concerning the PTO shaft.

Setting the height of the drawbar

Set the height of the drawbar according to the tractor's hitch type. Standard tractor hitch heights range from 450-500 mm (17"-20") or 900-1000 mm (35"-39").

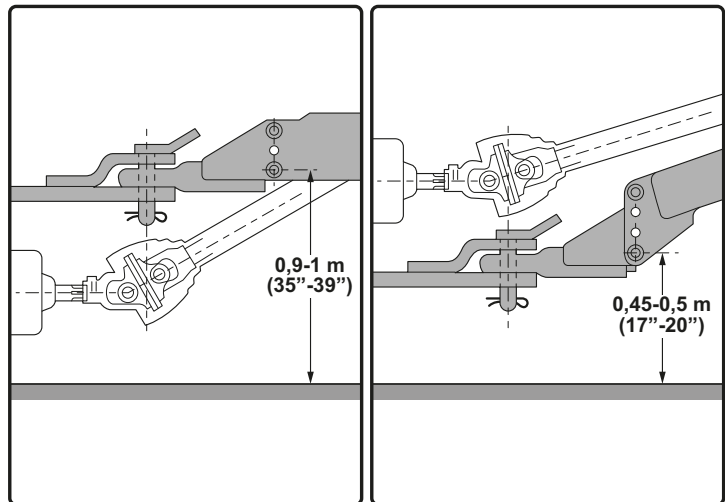

- **Height 450-500 mm (17"-20"):** the drawbar must be fastened to the hole (I) using the screw (C).
- **Height 900-1000 mm (35"-39"):** the drawbar must be fastened to the hole (II) using the screw (C).

Modifying the height of the drawbar

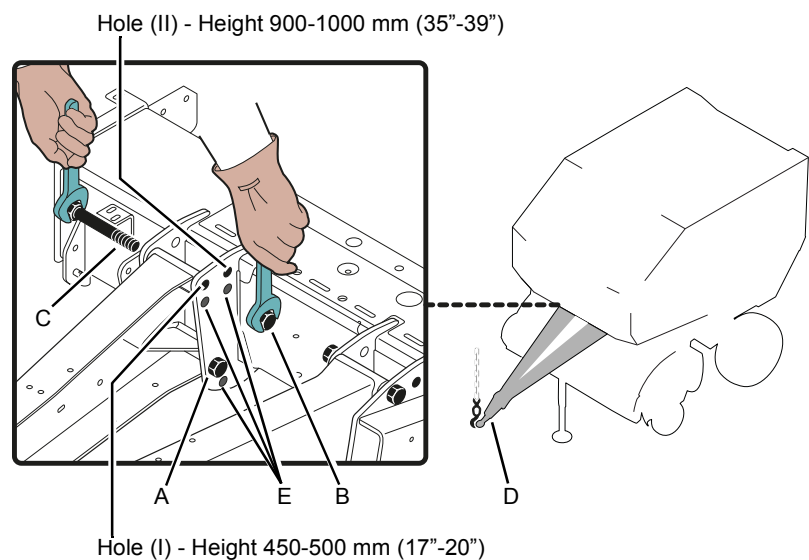

- ▶ Anchor the drawbar (D) to a lifting device with a suitable capacity.
- ▶ Loosen the screws (A).
- ▶ Unscrew the nuts (B), and remove the screws (C).
- ▶ Lift or lower the drawbar (D) until either hole (I) or hole (II) is aligned.

Preliminary operations

- ▶ Insert and tighten the screws (C).
- ▶ Tighten the screws (A).
- ▶ Remove the lifting device.

NOTICE

If the machine is equipped with 500/50-17" - 550/45-22.5" size tires, the holes (E) can be used to fasten the drawbar (D).

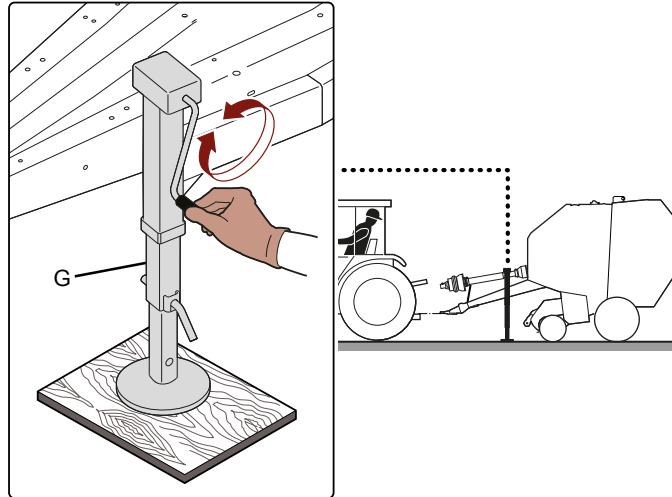

- ▶ Adjust the support leg (G) so that the drawbar's eyelet is at the same height as the tractor's hitch.

Hole (II) - Height 900-1000 mm (35"-39")

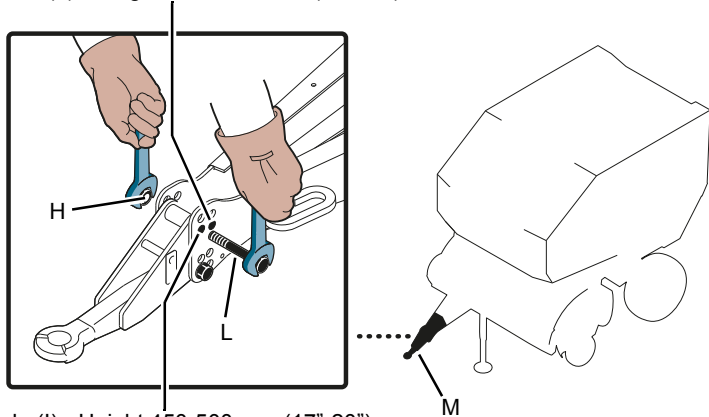

Hole (I) - Height 450-500 mm (17"-20")

- ▶ Unscrew the nuts (H), and remove the screws (L).

NOTICE

One screw (L) must be left inserted in order to use it as the fulcrum for the eyelet, thus facilitating the operations.

Preliminary operations

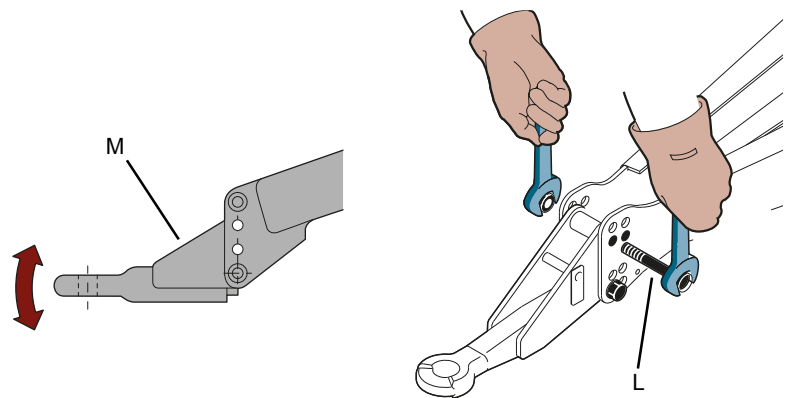

- ▶ Place the eyelet (M) in its horizontal position.
- ▶ Insert and tighten the screws (L).

CAUTION

Upon completing the operation, make sure that the locking screws have been tightened properly in order to prevent the risk of the drawbar and the eyelet becoming detached.

Setting the length of the PTO shaft

NOTICE

Only check the length of the PTO shaft after having decided which tractor the machine will be coupled to.

WARNING

The PTO shaft must be long enough so that it does not jam at its minimum extension, or slip out at its maximum extension.

- ▶ Couple the machine to the tractor without assembling the PTO shaft (See “Coupling the machine to the tractor”)

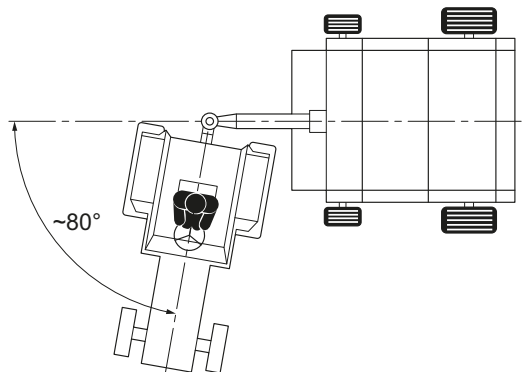

- ▶ Steer the tractor to 80° with respect to the machine.
- ▶ Make sure the tractor's PTO is disengaged.
- ▶ Turn off the engine, engage the parking brake, and remove the ignition key.

Preliminary operations

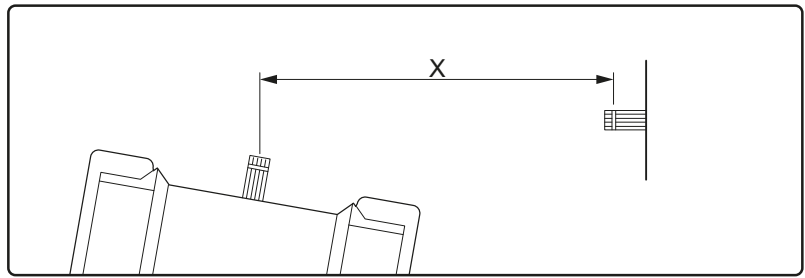

- ▶ Measure the distance (X) between the tractor's PTO and the PTO shaft's connection point on the machine.

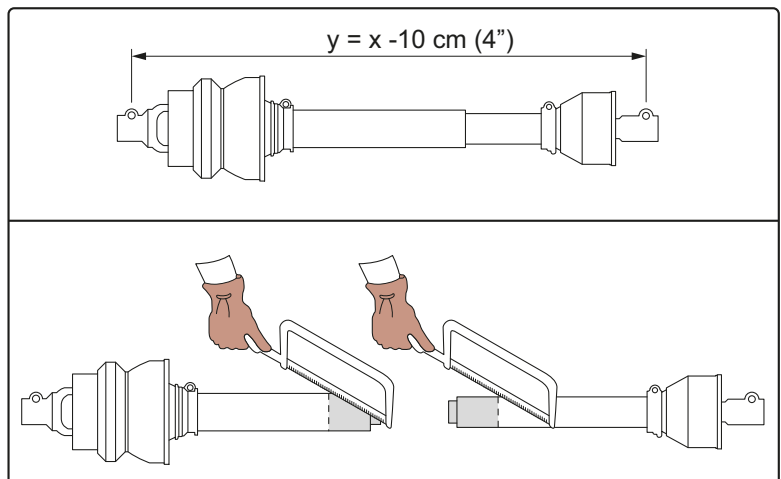

- ▶ Measure the length (Y) of the PTO shaft.



NOTICE

The length (Y) of the PTO shaft (completely closed) must be less than 10 cm (3.9") at the distance (X). If this is not the case, cut the excess part from the "female" side of the shaft and the "male" side of the shaft. Cut the protective tubes in the same manner.

- ▶ After having cut the excess portions, remove any burrs and cutting residues.

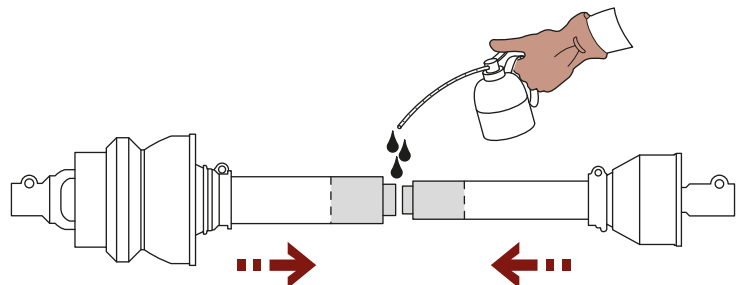

- ▶ Thoroughly lubricate the "male" and "female" parts, and then reassemble the shaft.

Preliminary operations

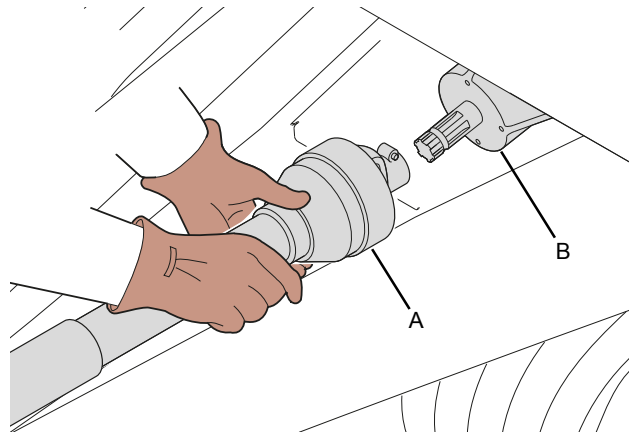

- ▶ Attach the PTO shaft (A) to the splined shaft on the machine's gearbox (B).



DANGER

The PTO shaft must be connected first to the machine's PTO, and then to the tractor's PTO. This helps to prevent the possibility of lethal "whiplash" in the event that the tractor's PTO is unexpectedly activated. The PTO shaft's constant velocity joint must be facing the tractor's PTO.

- ▶ Connect the protection devices' safety chains: one to a component on the machine, and the other to a component on the tractor.
- ▶ Perform a test to make sure that the PTO shaft's length is suitable to prevent it from "jamming" at its minimum extension, or "slipping out" at its maximum extension.



NOTICE

Consult the manufacturer's manual for further details concerning the PTO shaft.

Coupling the machine to the tractor

- ▶ Upon receiving the machine, check the category and characteristics of the tractor to which it is to be coupled in order to ensure its stability and proper functionality.

WARNING

The operations required to connect the machine to the tractor must be performed by one operator only, after having prepared for the necessary safety measures.

Connecting the towing hitch to the machine's eyelet

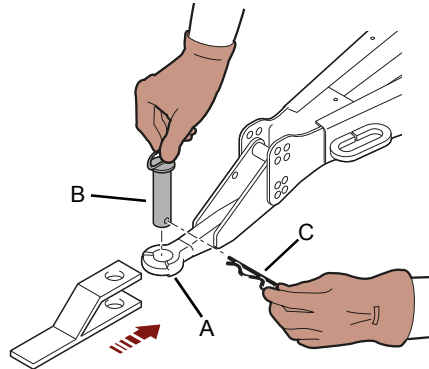

- ▶ Remove the locking pin and the hitch pin (B) from the tractor's hitch.
- ▶ Reverse the tractor until the towing hitch lines up with the eyelet (A).
- ▶ Adapt the height of the drawbar to the height of the towing hitch (see "Setting the height of the drawbar").
- ▶ Adapt the length of the PTO shaft supplied along with the machine (See "Setting the length of the PTO shaft").

WARNING

Turn off the engine, engage the parking brake, and remove the ignition key.

- ▶ Insert the hitch pin (B) and its locking pin (C).

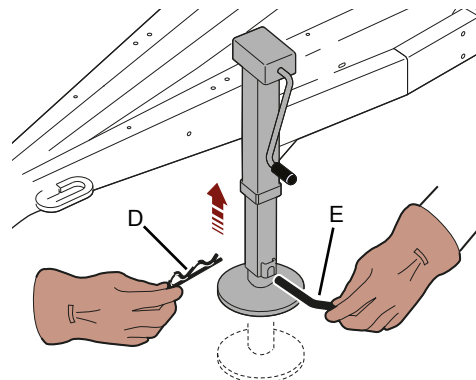

- ▶ Remove the locking pin (D) and the hitch pin (E), lift the leg and then fasten it again.

Preliminary operations

Connecting the PTO drive shaft

WARNING

Make sure the tractor's PTO is disengaged. Make sure that the connectors on the PTO shaft and the tractor's PTO are not damaged. Clean them thoroughly, and lubricate them with grease.

- ▶ Connect the PTO shaft to the tractor's PTO.

DANGER

The PTO shaft must first be connected to the machine's PTO, and then that of the tractor. This helps to prevent the possibility of lethal "whiplash" in the event that the tractor's PTO is unexpectedly activated. The PTO shaft's constant velocity joint must be facing the tractor's PTO.

- ▶ Connect the protection devices' safety chains: one to a component on the machine, and the other to a component on the tractor.

Connecting the hydraulic system

NOTICE

The hydraulic system's hoses are marked with the following information: maximum pressure, manufacturer, production date, reference code.

An example of how the information is indicated on the hydraulic hoses is provided below.

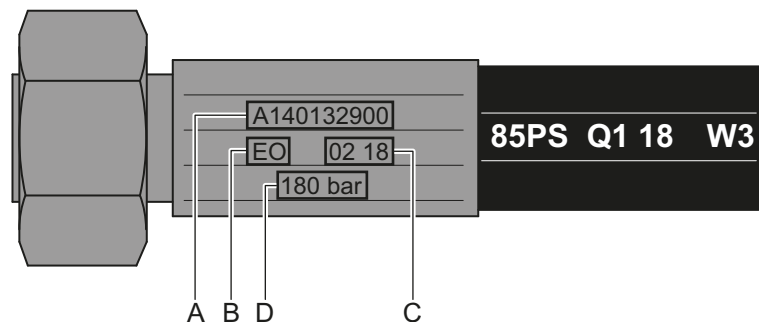

Reference	Meanings
A	Code of the hydraulic hose
B	Manufacturer's name
C	Hydraulic hose production date
D	Maximum operating pressure

For more information on connecting the hydraulic hoses to the tractor, see the hose connection decal applied to the machine.

Preliminary operations

The hoses are identified by different colored bands, depending on their use.

**USE ONLY IF
TRACTOR IS
EQUIPPED WITH
CASE DRAIN/
FREE RETURN
TO SUMP**

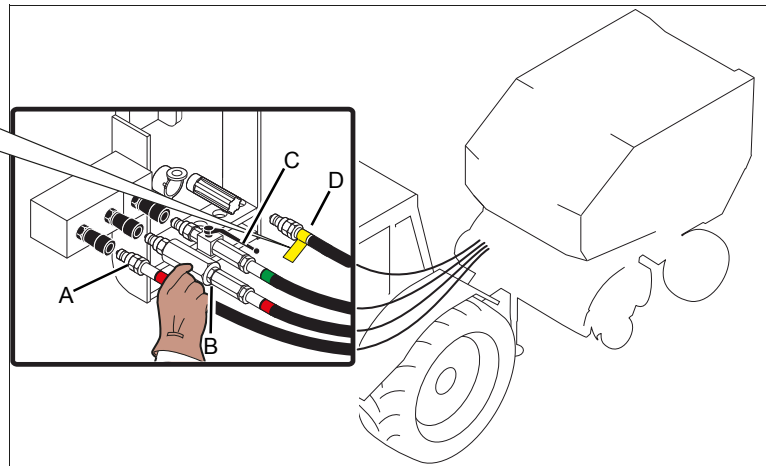

- ▶ Thoroughly clean the quick couplings.
- ▶ Connect the hoses marked with the red band (A-B) to the couplings on the tractor's double acting control valve (variable chamber round baler).
Connect the hose (A) to the coupling on the tractor's single acting control valve (fixed chamber round baler).
The hoses (A-B) connect the tailgate's opening/closing hydraulic system and the bale density hydraulic system.
- ▶ Connect the hose (C) marked with the green band to the couplings on the tractor's single acting control valve.
The tube (C) connects the hydraulic system of the pick-up/feeding devices, and can be identified by the lock valve next to the coupling.
- ▶ Only use the hose (D) marked with the yellow band if the tractor is equipped with the free return to sump hose, as indicated on the corresponding label on the machine.



NOTICE

Only use original quick couplings that will ensure a proper connection. Do not use "push-pull" type quick couplings.

Connecting the electrical system

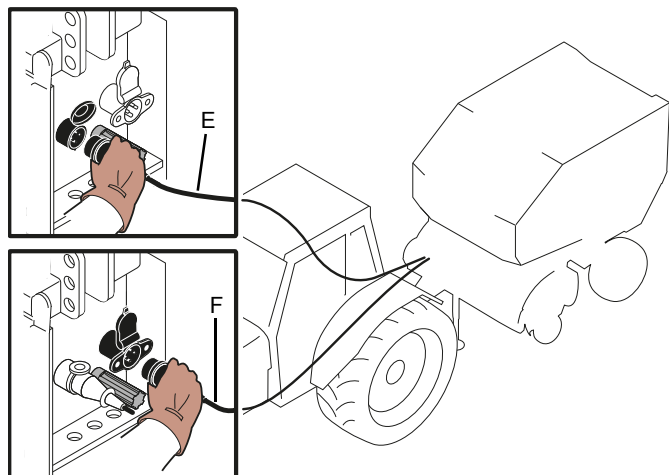

Preliminary operations

- ▶ Connect the cable (E) that provides electricity to the signaling devices.
- ▶ Connect the cable (F) that provides electricity to the baler's electronic control system (See "Electronic control system").

NOTICE

If the tractor is not equipped with an electrical outlet for the baler, an expert operator will have to install the supplied outlet. The outlet must be protected by a 30 A fuse. When connecting the power supply systems, avoid twisting the cables and/or the hoses. The 3-pin outlet's terminals (+ and -) must be directly connected to the terminals on the battery (+ and -) using cables with a cross-section of at least 6 mm².

Connecting the electronic control system

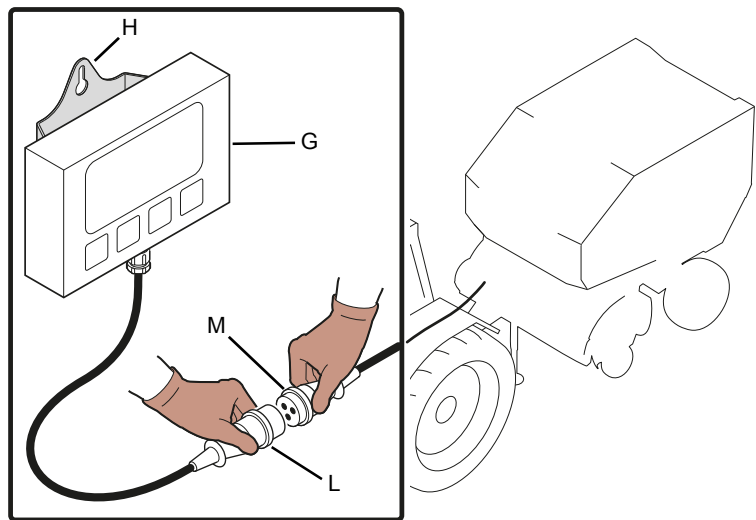

- ▶ The power cable on the baler is equipped with a 3-pin plug to be connected to the 3-pin outlet on the tractor. The tractor's power supply must be capable of providing up to 20 Amps of current to the baler.

CAUTION

Make sure that the outlet on the tractor is protected by a 20A fuse in order to prevent damage in the event of a short circuit on the supply cable.

Make sure that the electrical cable from the baler to the tractor is mounted in such a way that the tractor's wheels and the PTO shaft will not damage the cable itself.

- ▶ Install the electronic control system (G) complete with support (H), supplied along with the machine, inside the tractor's cab. In order to ensure maximum operator comfort, it is recommended to install the unit in front of the driver rather than to the side. This will facilitate the viewing of the driving direction indicators during the baling operations.
- ▶ Connect the plug (L) to the outlet (M) on the machine's main

electrical cable.

Uncoupling the machine from the tractor

WARNING

Turn off the engine, engage the parking brake, and remove the ignition key.
Disconnect the machine in a level and stable area that can only be accessed by authorized operators, in such a way as not to create an obstacle. The machine's reconnection to the tractor will be easier if the disconnection is performed in such a way as to always ensure a constant height of the eyelet with respect to the ground.

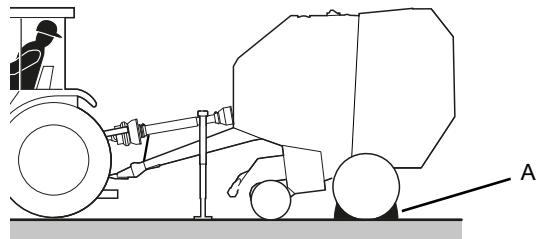

- ▶ Insert the safety wedges (A).
- ▶ Disengage the power cables.
- ▶ Disengage the electronic control system.
- ▶ Disengage the hydraulic system's hoses from their quick couplings.

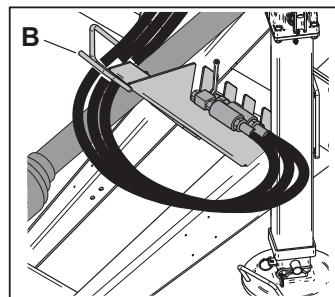

- ▶ Connect the quick couplings to the specific support (B) in order to avoid damage and to keep their interiors free of any foreign material.
- ▶ Wind the electrical cables and hydraulic hoses, and hang them on the dedicated support (B).

NOTICE

Avoid twisting the cables and/or hoses.

- ▶ Disconnect the chain from the PTO shaft (tractor side).

Preliminary operations

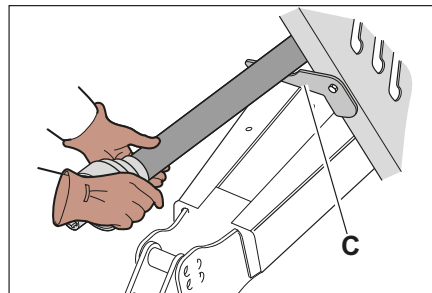

- ▶ Disconnect the PTO shaft from the tractor, and position it on the support (C).



DANGER

The PTO shaft must only be disengaged from the tractor's PTO.

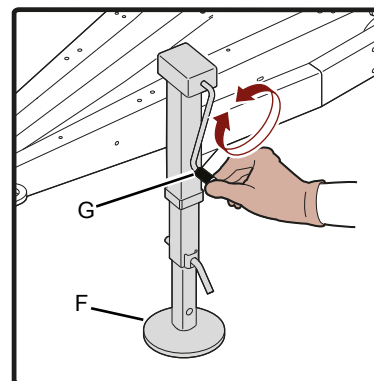
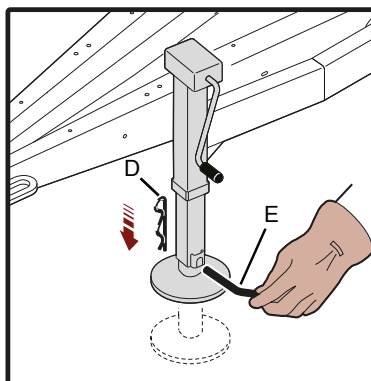

- ▶ Remove the locking pin (D) and the hitch pin (E), lower the support leg, and reinsert the hitch pin complete with the locking pin.
- ▶ Adjust the height of the support leg (F) using the handle (G).

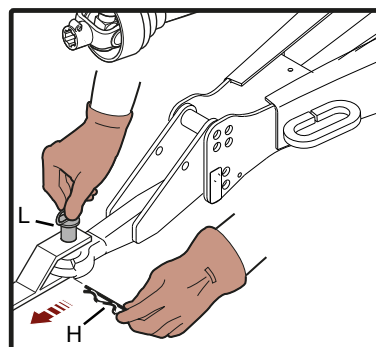

- ▶ Remove the locking pin (H) and the hitch pin (L) to disengage the tractor from the machine.



CAUTION

DO NOT push the pin out from below using your finger.

Preliminary operations

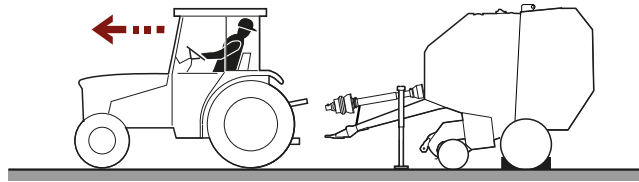

- ▶ Slowly move the tractor forward in order to disconnect it from the machine.

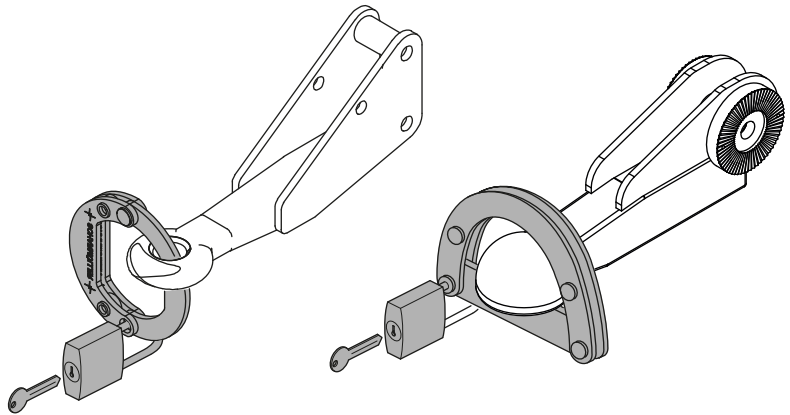

- ▶ Insert the safety stopper into the towing eye in order to prevent any unauthorized use of the machine.



WARNING

If the machine is equipped with an air braking system, make sure the air system's hoses are disconnected in the proper sequence.

Disconnect the hoses in the following sequence:

- 1st coupling with red hose
- 2nd manual engagement of the parking brake
- 3rd coupling with yellow hose.

Storing the machine at the end of season



NOTICE

Before storing the machine, it is recommended to carry out a number of general maintenance operations, which will help to ensure its proper functionality when the new harvest begins.

- ▶ Disconnect the machine from the tractor (See "Uncoupling the machine from the tractor").
- ▶ Disconnect the control box, and store it in a dry and sheltered place.
- ▶ Remove any product and dust residues from all of the machine's parts, especially the baling chamber.



NOTICE

Avoid spraying pressurized jets of water onto the bearings' seals.

Preliminary operations

- ▶ Check the functionality of all the machine's parts and replace them with original spare parts if necessary.
- ▶ Check that the PTO shaft is properly connected to the machine and that it is resting on the dedicated support with all the protection elements intact and working properly.

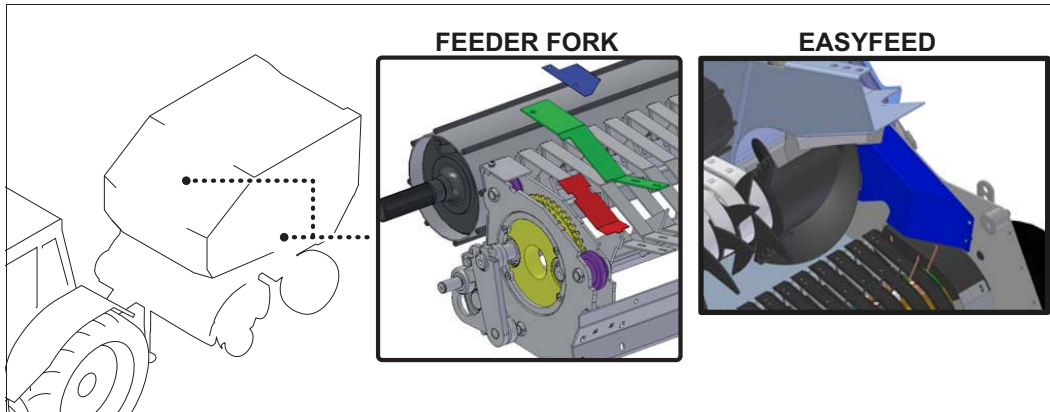

- ▶ On the models equipped with double feeder fork intakes or the EasyFeed feeding device, remove the lateral closures and clean the product feeding unit's internal transmission.
- ▶ Thoroughly clean and lubricate the transmission chains.
- ▶ Grease all the components fitted with greasers.
- ▶ Lubricate all the sliding surfaces, especially the hydraulic cylinders' rods.
- ▶ Apply an anti-rust treatment to all the unpainted parts.
- ▶ Keep the baling chamber's belts tightened in order to reduce the risk of deformation and extend their service life.
- ▶ Apply a specific product (for example talc) to the net binding unit's drive rollers in order to prevent their rubber surfaces from deteriorating.
- ▶ Protect the electrical wires' connectors using the appropriate caps.
- ▶ Protect the hydraulic hoses' quick couplings using the appropriate caps.
- ▶ Store the machine in a sheltered location (preferably indoors) that can only be accessed by authorized personnel.

Putting the machine back into service



NOTICE

Before using the machine after an extended period of inactivity, carefully check to make sure that its main components are working properly.

In particular, carry out the following operations:

- ▶ Check the wear status and pressure of the tires.
- ▶ Check for any liquid leaks.
- ▶ Check the general conditions of the hydraulic hoses.
- ▶ Check the functionality of all the safety devices.
- ▶ Check the oil level in the centralized lubrication system and top it up if necessary.
- ▶ Lubricate all the greasing points.

- ▶ Carry out any necessary maintenance operations.
- ▶ Check that the PTO shaft is correctly installed, and that all the PTO guards are undamaged and working properly.
- ▶ Check the tightening of the fastening screws for the main devices (drawbar, towing eyelet, and wheel fastening nuts).
- ▶ Connect the machine to the tractor (See “Coupling the machine to the tractor”).
- ▶ Perform a number of test maneuvers to check the connection, the proper functionality of the controls, and the functionality of operating units, including the safety devices.

Decommissioning the machine

WARNING

Make sure that the machine is in safe conditions when disposing of it.

WARNING

In order to avoid potential hazards for individuals and the environment, be sure to disconnect and render all the power sources unusable (electrical, pneumatic, hydraulic, etc.) and drain any liquids (lubricants, oils, etc.) that may be present.

WARNING

Deposit the machine in a suitable area that cannot be easily accessed, and that's properly fenced off in order to prevent anyone from having access to it.

Preliminary operations

Scrapping the machine

- If necessary, the individuals responsible for carrying out the machine's demolition operations must implement a "safety plan" in order to protect all the individuals directly involved, and must rigorously apply all the current safety regulations applicable to work environments and mobile work sites.
- During the demolition activities, sort all the components according to their chemical characteristics, and dispose of them in accordance with the current applicable regulations.

CAUTION

Do not dispose of non-biodegradable products, lubricating oils and non-ferrous materials (rubber, PVC, resins, etc.). These materials must be disposed of in accordance with the current regulations.

Machine disposal

CAUTION

Dispose of the machine by sorting the demolished parts based on their materials, and dispose of each of the components in accordance with the current waste disposal regulations in the machine's country of use.

Recommendations for use and operation

WARNING

The incidence of accidents caused by the use of machinery depends on many factors that cannot always be prevented and controlled. Some accidents can depend upon unforeseeable environmental factors, while others mainly depend upon the operator's conduct.

WARNING

In addition to being authorized and properly trained, if necessary, the operator must also perform certain maneuvers in order to identify the main functions and controls when using the machine for the first time. Prior to use, the operator must check that the safety devices are properly installed and functioning. In addition to meeting these requirements, the operator must also apply all the current safety regulations.

- The operators must read and fully understand all the contents of the user manual in order to become familiar with all the machine's controls and operating functions.
- The User Manual must be kept in a known and easily-accessible location in order to ensure that it is always available for consultation.

CAUTION

Although the machine has been designed and manufactured to operate under harsh environmental conditions, the scheduled maintenance interventions must nevertheless be carried out regularly. Proper maintenance will ensure the machine's best possible performance, an extended service life, and constant compliance with the safety requirements.

WARNING

In addition to personal experience and knowledge of all the safety details, the suggestions and instructions contained herein must also be taken into account in order to improve the safety conditions while the machine is in function. Check that the PTO shaft is correctly installed, and that all the PTO guards are undamaged and working properly.

DANGER

The PTO shaft must be connected first to the machine's PTO, and then to the tractor's PTO. This helps to prevent the possibility of lethal "whiplash" in the event that the tractor's PTO is unexpectedly activated.



WARNING

Never use the PTO shaft as a pedestal for performing any types of interventions upon the machine.

Always deactivate the PTO to stop the machine's functions during sharp turns and movements, especially during road travel.

Periodically check the tightness of the fastening screws on the main components (drawbar, towing eyelet, wheels, and wheel axles), and the wear status and pressure of the tires.

Check that the hydraulic system's hoses are undamaged and do not show any signs of oil leaks.

Check the work area in order to assess the most suitable conditions (slope, roughness of the terrain etc.) for operating the machine safely.

Make sure that all the lighting devices installed on the machine and the tractor are functioning properly in order to allow them to be utilized under conditions of reduced visibility, at night, and on the road.

Do not attempt to remove any blockages while the machine is moving: only carry out the operations after having stopped the machine in safe conditions.

In the case of collisions with foreign objects, stop the machine, turn off the tractor's engine, check for any damage incurred, and carry out the necessary repairs.

Do not allow unauthorized personnel to approach the work area while the machine is in use. If necessary, stop the machine immediately and instruct the unauthorized individuals to leave the hazardous areas.

Instructions and advice for use

Preliminary work inspections

Windrow size and type

NOTICE

Before operating the machine, carry out a number of preliminary checks in order to ensure its proper performance.

- Set the diameter and density of the bale and the binding parameters based on the type of product to be baled (See “Using the machine”).
- Check that the machine is supplied with a sufficient number of net reels. If not, arrange for them to be supplied (See “Net binding unit”).
- Check that the machine is supplied with a sufficient number of twine reels. If not, arrange for them to be supplied (See “Twine binding unit”).

In order to better exploit the machine's potential and obtain good bale formation, follow the instructions provided below.

- **Uniform and properly bound bales:** in order to obtain bales with these features, follow the direction indications displayed by the LEDs on the electronic control system, and adapt the machine's trajectory and advancement speed based on the operating conditions.
- **Products that are not very dry:** during the collection of products with these characteristics, check to make sure that no product is coming out the upper part of the machine. If necessary, direct the tractor towards the side opposite to that where the product is coming out.
- **Short and/or dry products:** during the collection of products with these characteristics, reduce the power take-off's speed and increase the advancement speed in order to prevent blockages.

The quality of the finished bales also depends on the type of windrow (dimensions, humidity, type of product, etc.), for which some of the characteristics are listed below.

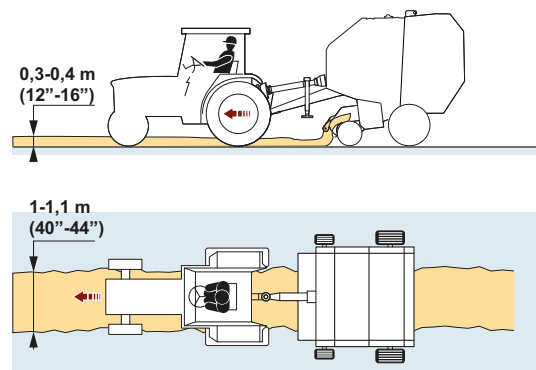

Windrow dimensions:

- Width 1-1.1 m (40"-44")
- Height 0.3-0.4 m (12"-16")

Humidity:

- HAY: percentage of humidity \approx 20%
- ENSILED PRODUCT: percentage of humidity \approx 40-55%

Preliminary operations

Properly prepared windrow

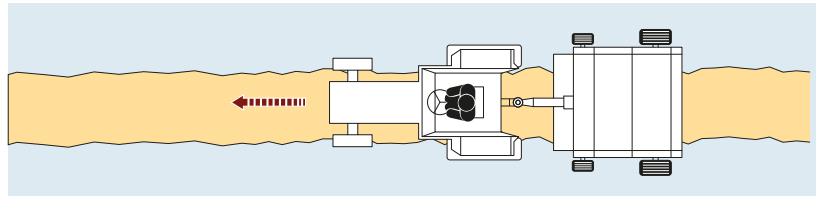

Keep a straight path, as shown in the illustration.

Narrow windrow

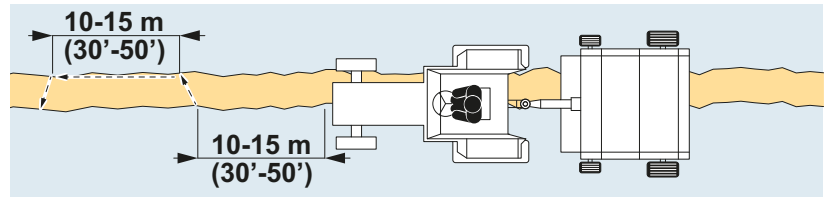

Follow the path shown in the illustration to uniformly feed the baling chamber.

Feeding the machine

After completing the checks, proceed as indicated.

- ▶ Position the machine on the windrow.
- ▶ Adjust the pick-up unit (See "Pick-up unit").
- ▶ Adapt the tractor's speed so that the speed of the power take-off is as close as possible to 540 RPM.
- ▶ Begin the product collection operation.
- ▶ Interrupt the tractor's advancement when the electronic control system emits an acoustic signal to warn that the bale has reached the set diameter.
The binding unit initiates the bale binding operation (net, twine or mixed).
Once the binding process has been completed, the electronic control system emits another acoustic signal to advise the operator that the tailgate can be opened to unload the bale.
- ▶ Make sure that there are no people and/or obstacles within the tailgate's range of action or in the bale unloading area.

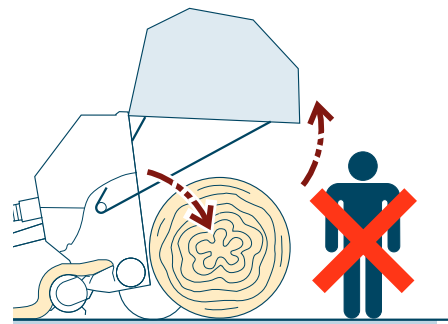
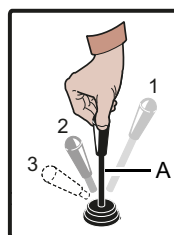

- ▶ Bring the lever (A) on the floating-position double acting control valve to its 1 position, and do not release it until the bale unloading operation has been completed.



DANGER

In the case of terrain with a slope that poses a risk of sudden and uncontrolled bale movements, unload the bale perpendicular to the slope. Use this precaution especially when the machine is equipped with a bale kicker.

Bale unloading

Machine “without bale kicker”

A bale can be unloaded in any one of the ways listed.

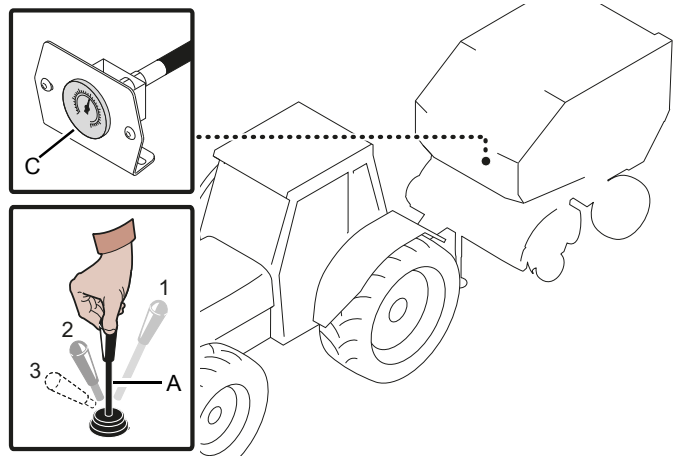

- ▶ During the binding operation, reverse the machine by 4-5 m (12'-16') into the area where the bale will be unloaded. This will save time.
- ▶ Unload the bale and move the machine forward to the beginning of the windrow.
During the forward movement, bring the lever (A) to its “” position to close the tailgate.
- ▶ Release the lever (A) when the pressure indicated on the pressure gauge (C) starts to increase.
This means that the bale density device has reached the set operating pressure.



CAUTION

If the electronic control system warns that the tailgate has not been closed properly, bring lever (A) to position “2” again, and then repeat the tailgate closing operation.

- ▶ Bring the lever (A) to position “3” (floating position) until the electronic control system signals that the machine has been properly closed and is ready for another baling operation; keep the lever in the floating position for the entire duration of the bale forming operation.

Preliminary operations

Machine “with bale kicker”

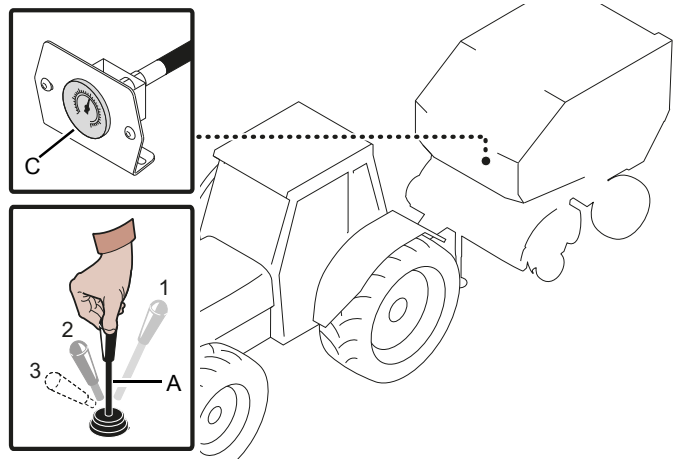

! NOTICE

When the bale kicker is installed, the bale unloading operation (opening and closing of the tailgate) can be carried out directly at the point where the bale has been completed, with no need for any additional maneuvers.

- ▶ Bring the lever (A) to position “2” to close the tailgate.
- ▶ Release the lever (A) when the pressure indicated on the pressure gauge (C) starts to increase. This means that the bale density device has reached the set operating pressure.

! CAUTION

If the electronic control system warns that the tailgate has not been closed properly, bring lever (A) to position “2” again, and then repeat the tailgate closing operation.

- ▶ Bring the lever (A) to position “3” (floating position) until the electronic control system signals that the machine has been properly closed and is ready for another baling operation; keep the lever in the floating position for the entire duration of the bale forming operation.

Road travel

- Road travel is only permitted for type-approved machines towed by a tractor of an appropriate category and with suitable features.
- The driver of the tractor towing the machine must comply with the current traffic laws in force.

! CAUTION

Before using the machine on public roads, check to make sure that it is in suitable condition (unworn tires at suitable pressure, lighting and signaling devices functioning properly, documents in order, etc.), in order to ensure compliance with the highway code in force.

- In addition to personal experience, the instructions and suggestions contained herein must also be taken into account in order to improve the safety conditions.

Preliminary operations

- Unload the bale from the machine.
- Make sure the tailgate is completely and correctly closed.
- Make sure that the machine is properly connected to the tractor.
- Raise the pick-up unit so that its wheels are off the ground.
- Close the safety valve for the hydraulic circuit that controls the pick-up unit.
- Clean the machine of any product residues in order to prevent them from being dispersed along the roadway.
- Check that all the indicator lights are visible and functioning properly.
- Check the wear status and pressure of the tires.
- Make sure the tractor's PTO is disengaged.



WARNING

Drive carefully and moderate your speed on rough roads. Take curves with caution in order to avoid compromising the machine's stability.

Preliminary operations

Page intentionally left blank

Features of the “FOCUS” control terminal

The “FOCUS” control terminal allows the entire baling operation to be supervised from the tractor's cab.

The following functions can be monitored:

- Bale diameter
- Bale shape indication, to fill the bale chamber uniformly
- Bale binding process (twine/net binding)
- Tailgate open/closed information
- Bale density/Soft core bale (depending on the model)
- Bale counter (day counter + total counter)
- Knife position indication on the Supercut chopping device & Drop floor (if present)

Description of controls

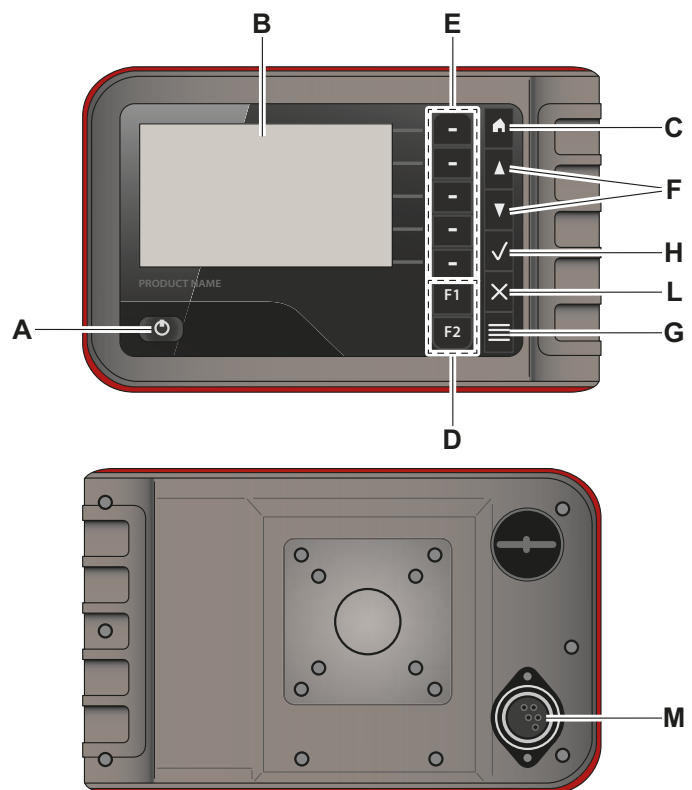

- A) On/Off switch
- B) LCD Display
- C) Home screen
- D) Soft-key buttons programmable by the user based on the specific work requirements.
- E) Function or “Soft-key” buttons located next to the display. The function of each “Soft-key” varies based on the image displayed next to it on the screen. The image indicates what happens when the “Soft-key” is pressed.
- F) Up & Down buttons. These are used to scroll through the menu's options/screens and to increase or decrease numeric values. The value will flash until confirmed with the OK button. If the OK button is not pressed to confirm the changes, the flashing value will revert to the value saved previously when the screen is exited.

Using the machine

- G) Control terminal settings.
- H) OK Button. Used to save a flashing programmed value, as well as to confirm any alarm or error messages.
- L) ESC Button. Press to cancel the value modifications in the programming area.
- M) Control terminal power connector.

General description of the equipment

- The “FOCUS” electronic control system has been designed and manufactured to program and control the production activities of the machine in question.
- The equipment must be properly installed in the cab in order to be used by the driver, who must have the necessary requirements for its safe use and operation.

Operating logic diagram

- The figure shows the screens that make up the operating terminal, and the list includes the description of the functions that can be displayed and/or programmed.
- Certain screens in the operating logic diagram may be displayed in different manners.
- For the screens that appear in different manners, the operating logic diagram is inserted at the start of the relative paragraph.

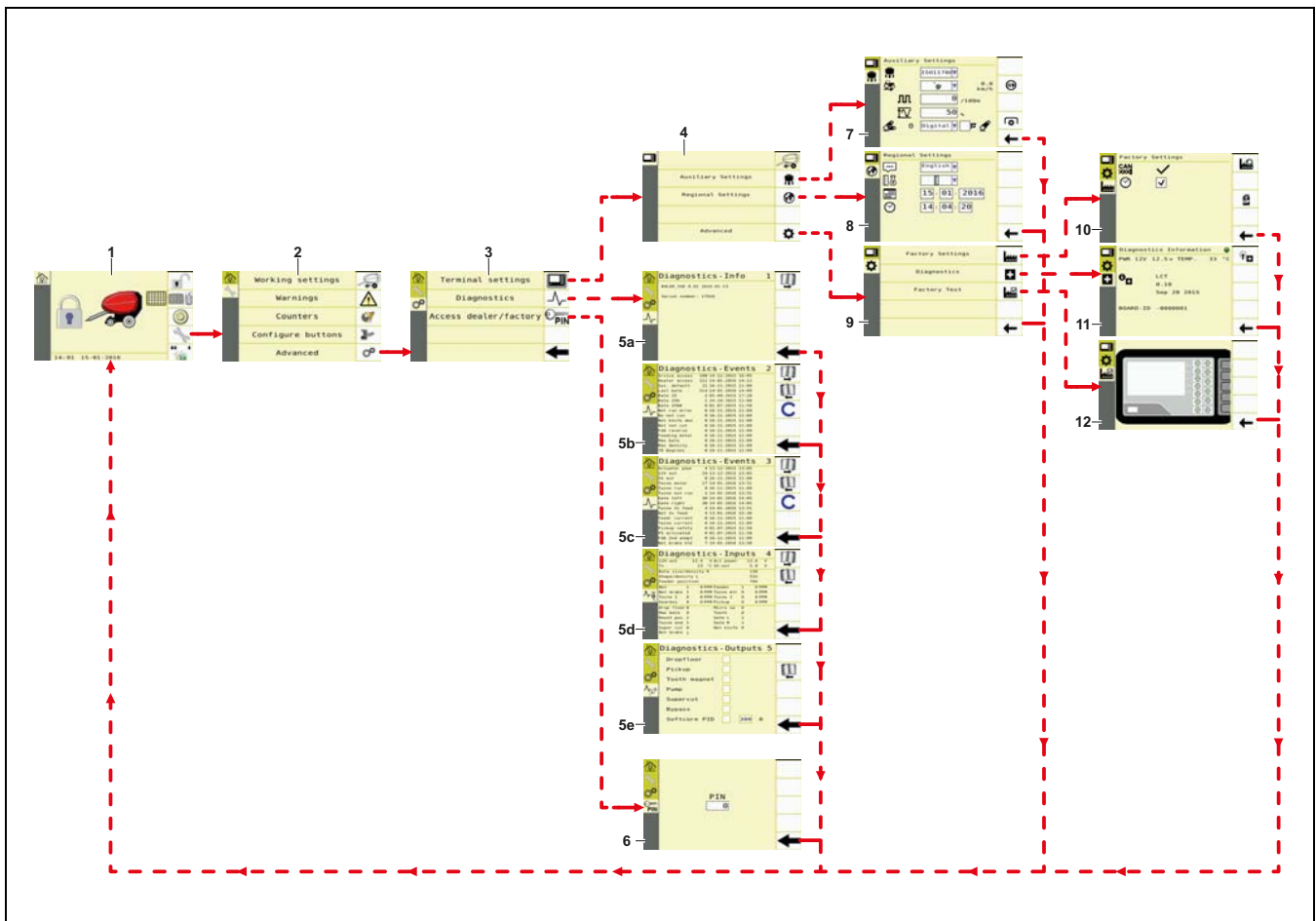

- 1) “Lock Screen” screen
- 2) “Set-up” screen
- 3) “Advanced settings” screen

- 4) "Terminal settings" screen
- 5) "Diagnostic" screen
- 6) "Dealer/Factory" screen
- 7) "Auxiliary settings" screen
- 8) "Regional settings" screen
- 9) "Advanced terminal" screen
- 10) "Factory settings - Terminal" screen
- 11) "Diagnostic information - Terminal" screen
- 12) "Factory Test - Terminal" screen

Twine binding

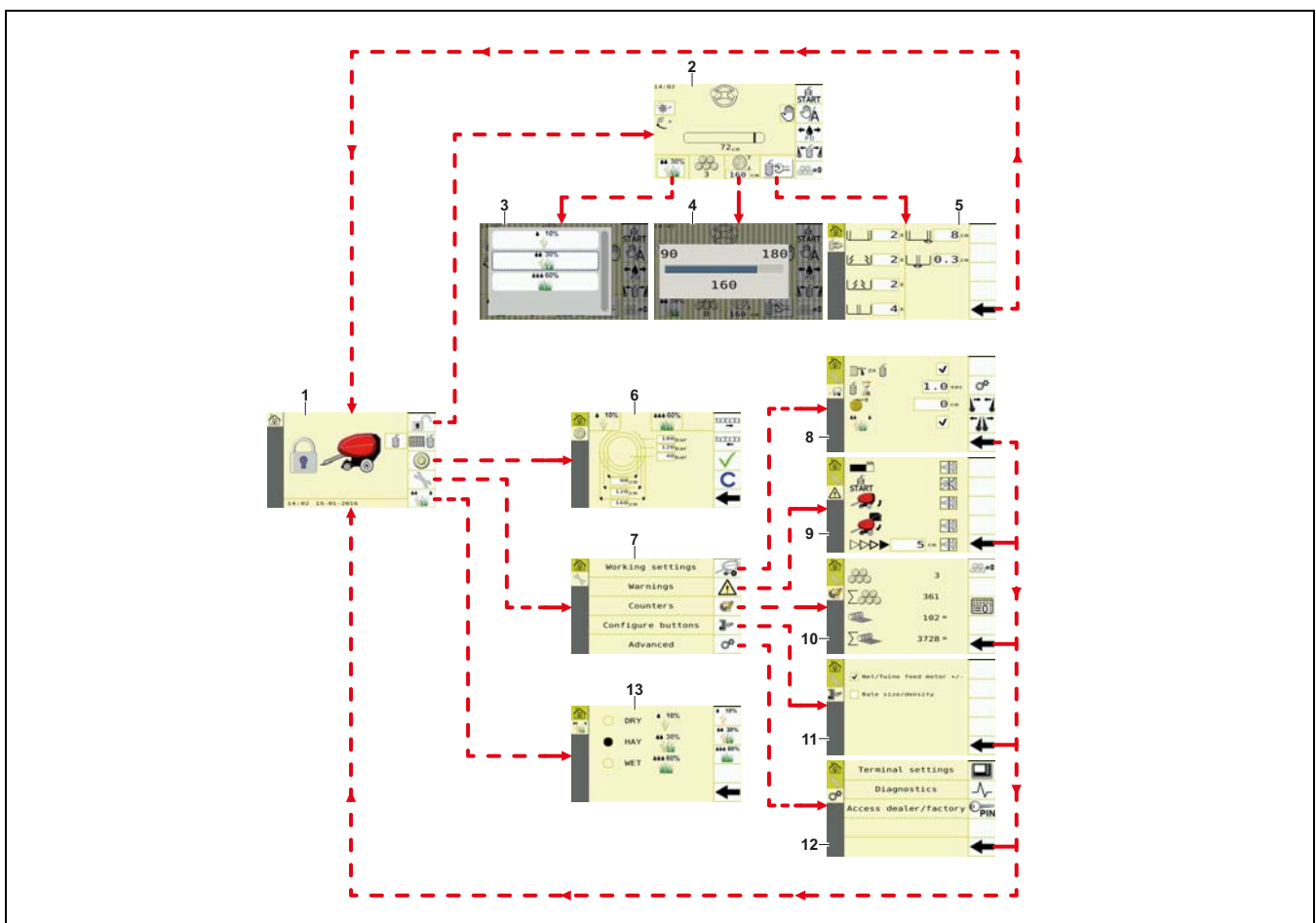

- 1) "Lock Screen" screen
- 2) "Work" screen
- 3) "Product humidity" screen
- 4) "Bale diameter" screen
- 5) "Twine binding programs" screen
- 6) "Bale density" screen
- 7) "Set-up" screen
- 8) "Working settings" screen
- 9) "Warnings" screen
- 10) "Counters" screen

Using the machine

- 11) "Configure buttons" screen
- 12) "Advanced settings" screen
- 13) "Product humidity" screen

Net binder

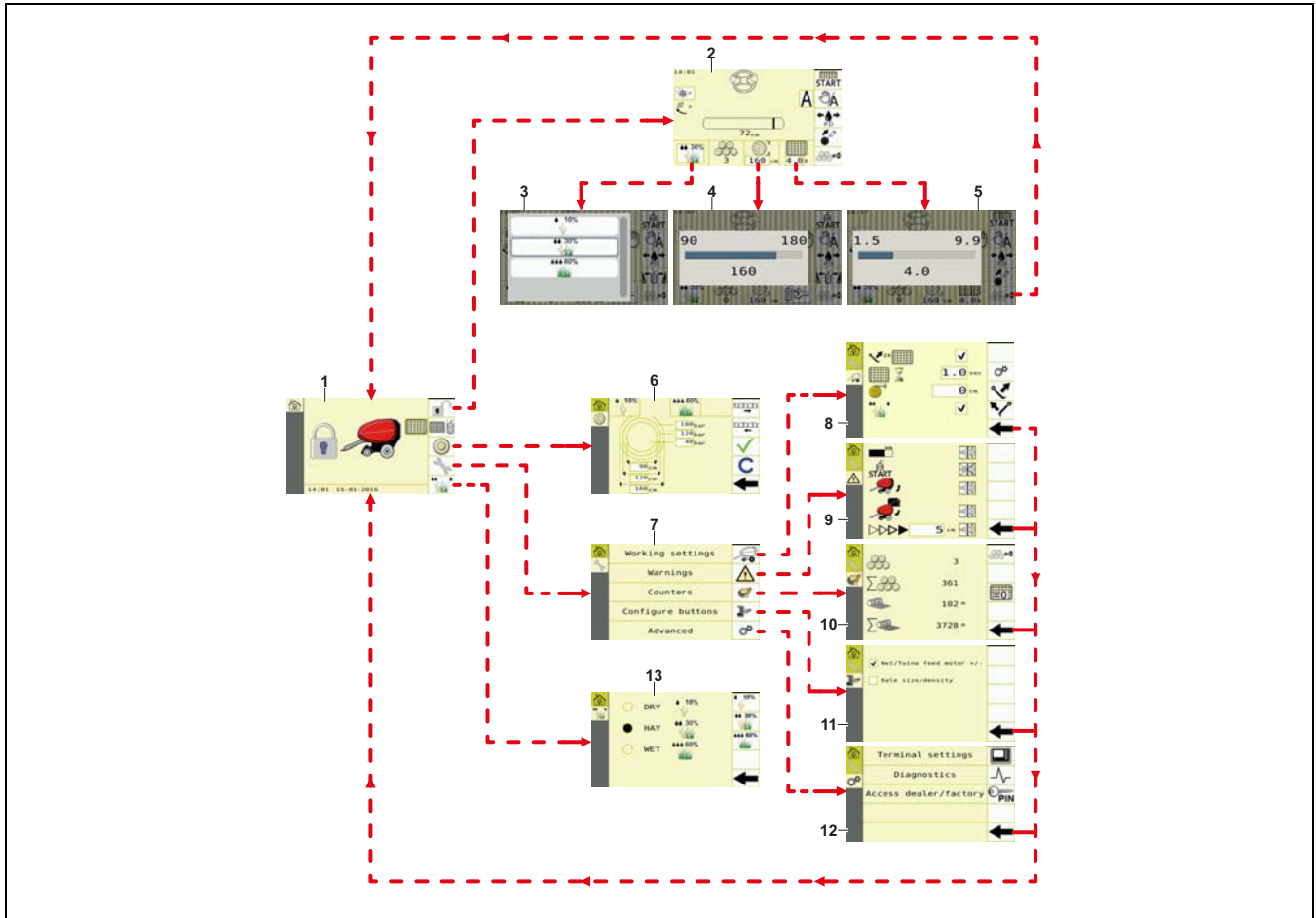

- 1) "Lock Screen" screen
- 2) "Work" screen
- 3) "Product humidity" screen
- 4) "Bale diameter" screen
- 5) "Net wraps" screen
- 6) "Bale density" screen
- 7) "Set-up" screen
- 8) "Working settings" screen
- 9) "Warnings" screen
- 10) "Counters" screen
- 11) "Configure buttons" screen
- 12) "Advanced settings" screen
- 13) "Product humidity" screen

Icon descriptions

Description of the “control bar” icons

Icon: serves to display the “Work” screen.



Icon: serves to select the type of binding to be utilized (net/twine).



Icon: serves to display the “Bale density” screen.



Icon: serves to display the “Set-up” screen.



Icon: serves to set the default programs based on the product’s humidity.



Icon: serves to enable net binding.



Icon: serves to enable twine binding.



Icon: serves to select the operating mode (manual/automatic).



Icon: serves to enable the machine's functional unit (pick-up / drop floor / knives) (If present on the machine)



Icon: serves to deactivate the net coil brake.



Icon: serves to activate the net coil brake.



Using the machine

Icon: serves to insert the twine.

First activation: serves to move the twine arms outwards

Second activation: serves to move the twine arms inwards

Third activation: serves to move the arms to the start work cycle position

When the icon is flashing, this means that the arms are not in the start work cycle position.

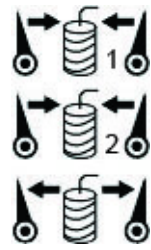

Icon: serves to reset the bale counter.



Icons: serves to display the next or previous tab.

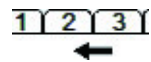
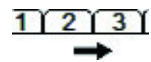

Icon: serves to confirm the entered values.



Icon: serves to cancel the entered values.



Icon: serves to display the previous screen.



Icon: serves to display the "Working settings" screen.



Icon: serves to display the "Warnings" screen.



Icon: serves to display the "Counters" screen.



Icon: serves to display the "Configure buttons" screen.



Icon: serves to display the "Advanced settings" screen.



Using the machine

Icon: serves to select the default settings for dry crops.



Icon: serves to select the default settings for hay.



Icon: serves to select the default settings for silo fodder / wet crops.



Icons: serves to activate the opening or closing of the twine guide arms.



Icons: serves to activate the opening or closing of twine/net insertion devices.



Icon: serves to reset the length counter of the net used in the binding phase.

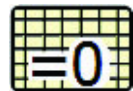

Icon: serves to display the "Terminal settings" screen.



Icon: serves to display the "Diagnostic" screen.



Icon: serves to display the "Dealer / Factory" screen



Icons: serves to display the next or previous screen.

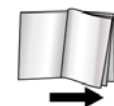

Using the machine

List of screen icons

Icon: indicates that the "Lock Screen" is being displayed.



Icon: indicates that net binding is selected.



Icon: indicates that twine binding is selected.



Icons: these indicate that the bale inside the chamber has an irregular shape.



Icons: these indicate the direction to be followed in order to obtain a bale with a regular shape.



Icon: indicates the direction to be followed in order to obtain a bale with a regular shape. The greater the number of displayed arrows, the greater the load unbalance of the baling chamber.



Graphic bar: displays the bale completion percentage with respect to the selected diameter.

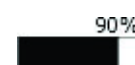

Icon: activates and deactivates the Pick-up unit.



Using the machine

Icon: activates and deactivates the Drop floor unit.



Icon: activates and deactivates the Knives.



Icon: serves to select the default settings for dry crops.



Icon: serves to select the default settings for hay.



Icon: serves to select the default settings for silo fodder / wet crops.



Icon: these serve to indicate the work cycle mode.

Automatic Cycle



Icon: these serve to indicate the work cycle mode.

Manual Cycle



Icon: displays the number of bales produced.



Icon: serves to program the number of external coils.

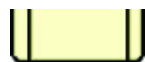

Icon: serves to program the number of coils in the intermediate external zone.



Icon: serves to program the number of coils in the intermediate internal zone.



Icon: serves to program the number of internal coils.



Icon: serves to program the distance of the external coils.



Using the machine

Icon: serves to program the distance of the internal coils.

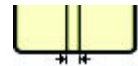

Icon: serves to program the bale diameter (only for machines with variable chambers).



Icon: serves to program the pressure of the bale (only for machines with fixed chambers).



Icon: serves to program the number of layers for the net binding operations.



Icon: serves to activate the second twine insertion attempt.



Icon: serves to program the time that must elapse between the end of the bale's formation and the start of the twine binding operation.



Icon: serves to activate the second net insertion attempt.



Icon: serves to program the time that must elapse between the end of the bale's formation and the start of the net binding operation.



Icon: serves to program the bale diameter correction factor (only for machines with variable chambers).



Icon: serves to enable the preset work programs.



Icon: activates an acoustic signal.



Icon: deactivates an acoustic signal.



Icon: indicates the number of bales produced.



Icon: Indicates the partial total of the net utilized.



Icon: Indicates the total net utilized.

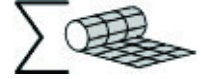

Icon: indicates the opening of the tailgate.



Icon: indicates the closure of the tailgate.



Parameter programming

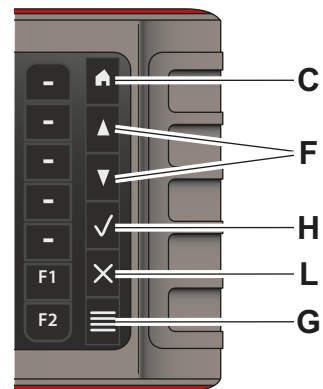

- ▶ View the desired screens (one at a time) upon which the programming or value change is to be carried out.
- ▶ Use the (F) buttons to select the values of the operating parameters, and press the (H) button to confirm and apply the changes.
- ▶ Press the (F) buttons to change the parameter value. The value of the parameter begins to flash.
- ▶ Press the (H) button to confirm the operation or press the (L) button to cancel it. The value of the parameter stops flashing and the cursor moves to the next programming area.
- ▶ Repeat the operations described under the previous points until all the parameters on the screen have been programmed.

Using the machine

Lock screen

- After a short delay the lock screen is displayed. When the lock screen appears, this means that the baler is in safe mode and that all of its electronic functions have been blocked.
- Based on the available selection of binding systems, a slightly different series of soft-keys will be displayed on the initial and operating screens.

Commands with net binding

Screen information

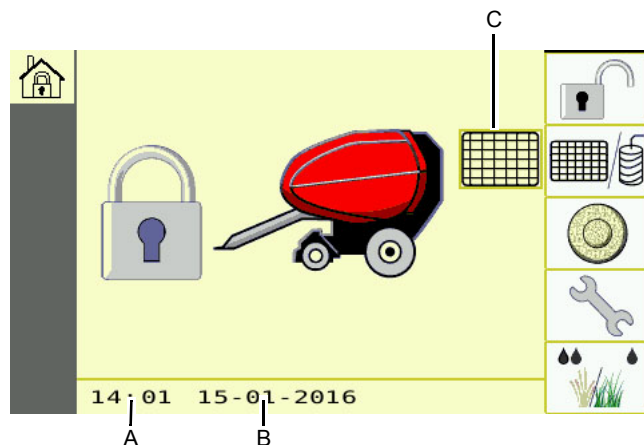

- A) Clock
- B) Date
- C) Net binding is enabled.

Soft-key functions



- D) Press to go to the WORK screen
- E) Press to switch to twine binding (when both twine and net systems are present)
- F) Press to go to the BALE DENSITY and soft core screen. (if the proportional and/or by-pass valves are present)



NOTICE

This function is not present on machines with manual bale density adjustment.

- G) Press to go to the SET-UP screen
- H) Press to select the preset operating program based on the type of crop.

Commands with twine binding

Screen information

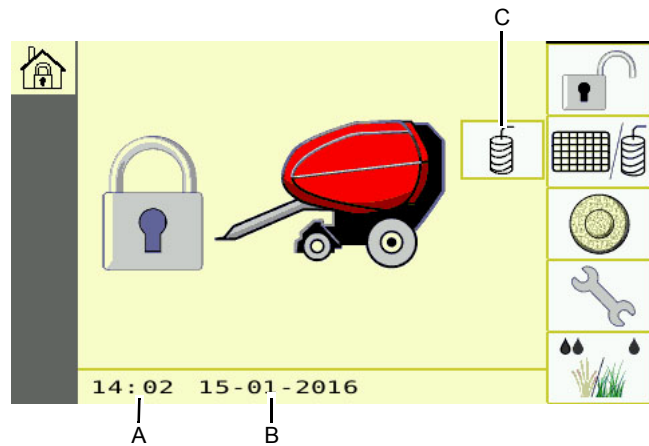

- A) Clock
- B) Date
- C) Twine binding is enabled.

Soft-key functions

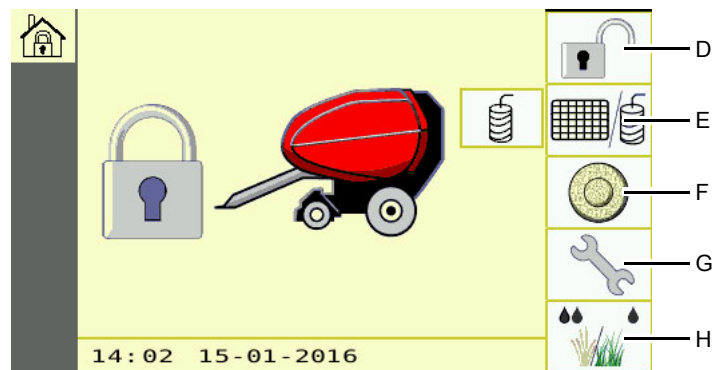

- D) Press to go to the WORK screen
- E) Press to switch to net binding (when both the twine and net binding systems are present)
- F) Press to go to the BALE DENSITY screen



NOTICE

This function is not present on machines with manual bale density adjustment.

- G) Press to go to the SET-UP screen
- H) Press to select the preset operating program.

Using the machine

Work screen

(*) Bale diameter setting

The diameter of the bale produced may vary by 5-7 cm (2-3 inches) due to various factors:

- The humidity level and the type of product can affect the extent to which the bale expands once released from the baling chamber. In general, dry product has a greater degree of expansion.
- The elasticity of the net, which varies depending on the brand. The more times the net is wrapped around the bale, the less it will expand.
- Delayed or inconsistent stops by made by the driver, based on the stop signal, will result in variations in the bale's diameter.

The default calibration values are based on the average conditions of use. If the machine's use in the field shows a marked difference in bale diameter (whether greater or lesser), this can be corrected (+/-) by accessing the "Bale diameter correction" work menu.

Net binding

Screen information

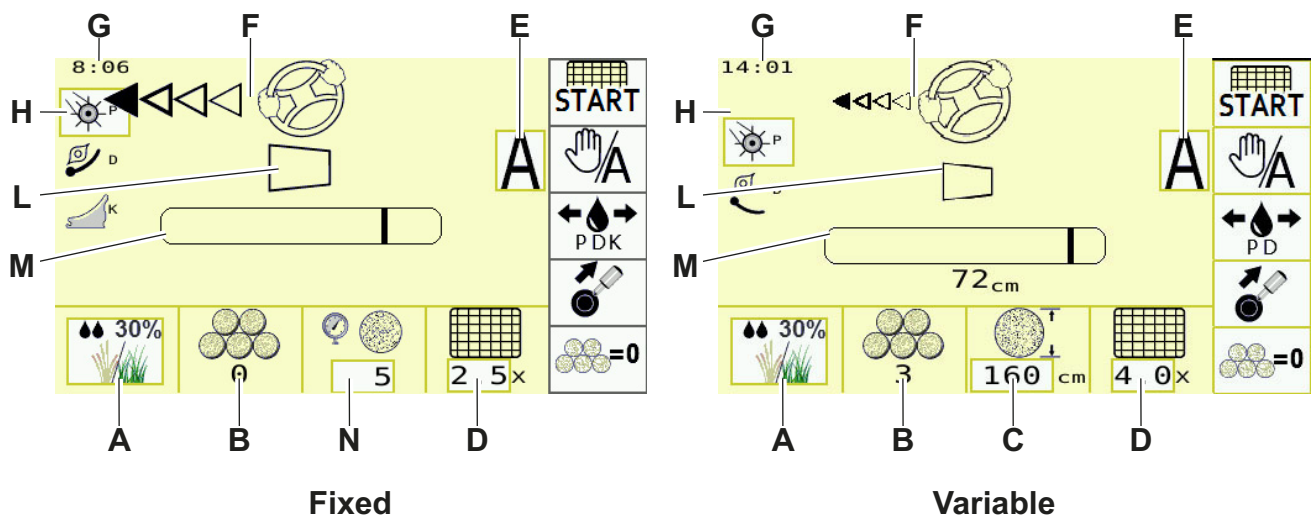

- A) Density and binding type setting based on the type of crop being baled: Dry (10%) / Hay (30%) / Wet (60%) / FLAX (Linen) with relative the pre-set values (density, binding parameters, etc.)
- B) Field bale counter
- C) Bale diameter setting (*)
- D) Indicates the number of net layers programmed
- E) Indicates the machine's functionality in AUTOMATIC/MANUAL mode
- F) Driving direction indicator with "steering wheel" guidance.
- G) Clock
- H) Indicates the pre-selection of the hydraulic pick-up, drop floor, or knives functions (if the knives or drop floor functions are not present, no icons are displayed here).
- L) Bale shape indicator.
- M) Bale growth bar: shows the increase in the bale's size during its formation
- N) Setting the bale density

Soft-key functions

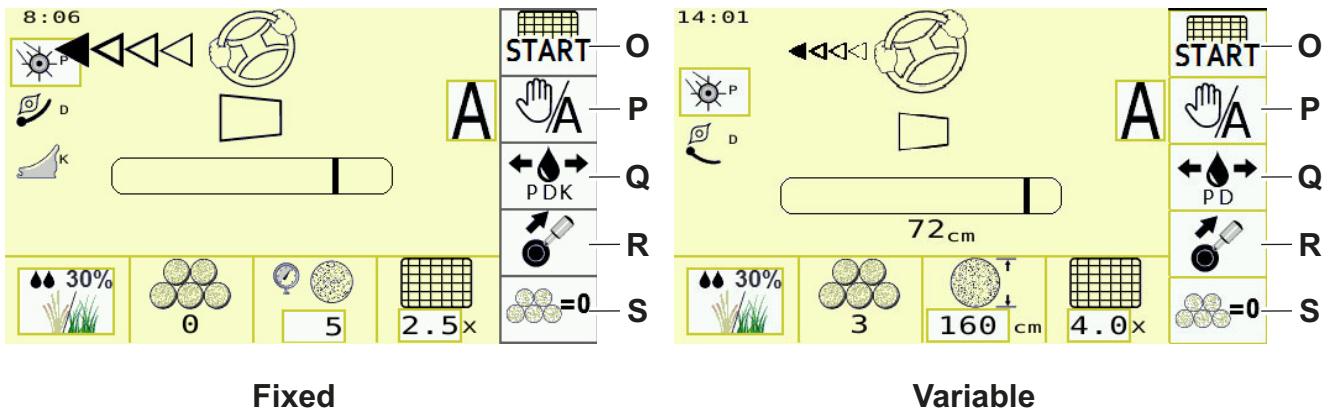

- O) Press to start the net cycle manually
- P) Press to switch to AUTOMATIC/MANUAL work mode
- Q) Press to pre-select the hydraulic pick-up, drop floor, or knives functions (if the knives or drop floor functions are not present, no icons are displayed here).
- R) Press to activate or deactivate the net coil brake.
If the icon is flashing, the net coil brake is disengaged.
- S) Press to reset the bale counter to zero.

Twine binding

Screen information

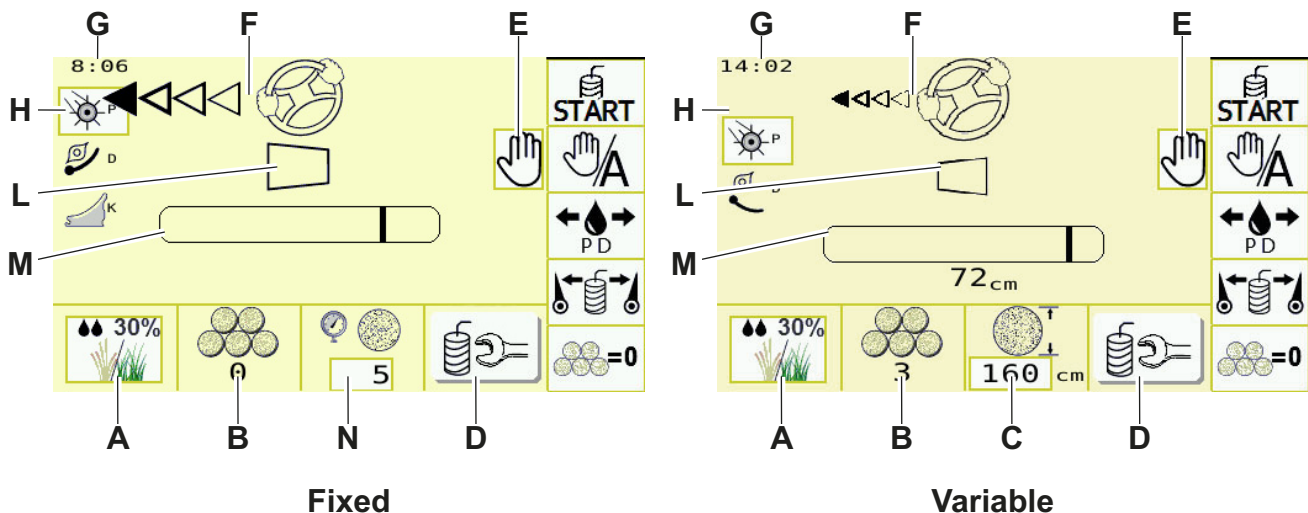

- A) Density and binding type setting based on the type of crop being baled: Dry (10%) / Hay (30%) / Wet (60%) / FLAX (Linen) with relative the pre-set values (density, binding parameters, etc.)
- B) Field bale counter
- C) Bale diameter setting (*)
- D) Press to set the twine binding parameters
- E) Indicates the machine's functionality in AUTOMATIC/MANUAL mode
- F) Driving direction indicator with "steering wheel" guidance.

Using the machine

- G) Clock
- H) Indicates the pre-selection of the hydraulic pick-up, drop floor, or knives functions (if the knives or drop floor functions are not present, no icons are displayed here).
- L) Bale shape indicator.
- M) Bale growth bar: shows the increase in the bale's size during its formation
- N) Setting the bale density

Soft-key functions

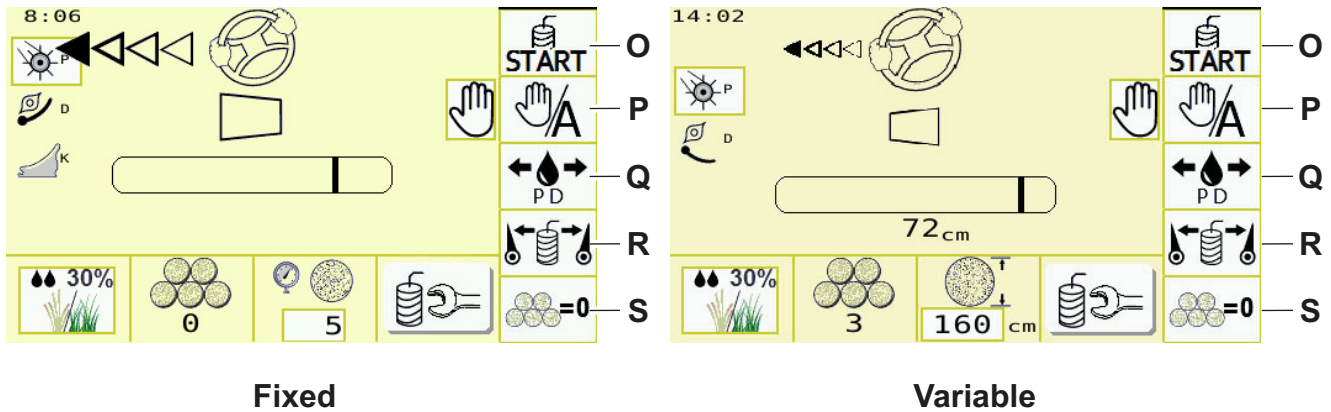

- O) Press to start the twine cycle manually
- P) Press to switch to AUTOMATIC/MANUAL work mode
- Q) Press to pre-select the hydraulic pick-up, drop floor, or knives functions (if the knives or drop floor functions are not present, no icons are displayed here).
- R) Press repeatedly to perform the twine insertion
 - First activation ; to move the twine arms outwards
 - Second activation; to move the twine arms inwards
 - Third activation; to move the arms in starting working position
 - If the icon is flashing, the arms are not in their working position**
- S) Press to reset the bale counter to zero.

Using the machine

Twine binding

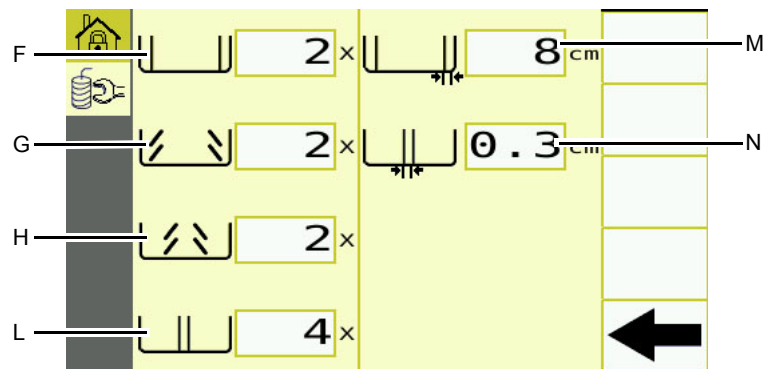
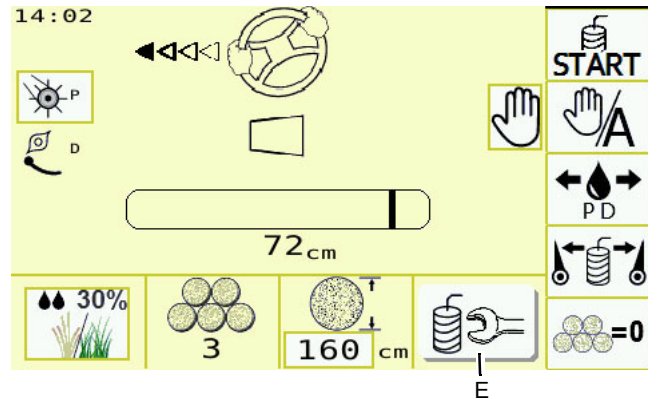

- ▶ To view or change the twine program:
 - ▶ Press the soft-key (**E**) to select the twine program customization screen.
Different settings may be required based on the crop type and the prevailing conditions.
 - ▶ The figures in the boxes (**F-G-H-L**) indicate the number of twine wraps that will be applied to each area of the bale.
 - ▶ Box (**M**) indicates the distance between the edge of the bale and the outermost twine on each side.
 - ▶ Box (**N**) indicates the distance between the twine and the middle of the bale (adjustment of the exact stopping point when the strings of twine meet in the middle of the bale).
Fine tuning this setting can improve the intersection of the strings of twine, and can reduce the size of the loose ends when the bale is unloaded.
 - ▶ The settings can be modified by using the UP/DOWN arrow buttons on the keyboard to select the desired box or boxes to be modified, and by pressing OK on the box to confirm.
 - ▶ Adjust the quantity using the “UP” and “DOWN” arrows.
 - ▶ Confirm the change by pressing “OK”.

Bale diameter setting

CAUTION

In order to perform the bale diameter setting, make sure the tractor's PTO is disengaged, stop the tractor with the engine running, and engage the parking brake.

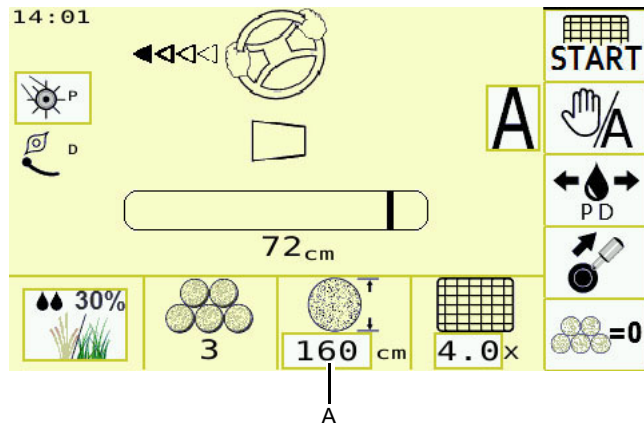

The bale diameter is adjusted remotely from the tractor's cab.

- ▶ Adjust the diameter using the “up” and “down” arrows (A) and confirm the change by pressing “OK”.
- ▶ Adjust the diameter using the “up” and “down” arrows.
- ▶ Confirm the change by pressing “OK”.

Using the machine

Bale density setting



NOTICE

Bale density depends on the tension of the belts in the baling chamber, and must be set according to the type of product to be baled, the weight of the bale, and the speed of the machine's forward movement.

- The greater the value of the set operating pressure, the greater the bale density.



NOTICE

An operating pressure that exceeds the maximum recommended value can cause damage to the machine, while an insufficient operating pressure will create unstable and defective bales.

- The table specifies the recommended pressure values based on the different types of product.

Type of product	Operating pressure bar (psi)
Straw	160-230 (2320-3336)
Hay crop	80-180 (1160-2610)
Ensiled product	50-150 (725-2175)

Manually setting the bale density

Models equipped with hydraulic block with manual valve

WARNING

Make sure the tractor's PTO is disengaged.
Stop the tractor with the engine running and engage the parking brake.

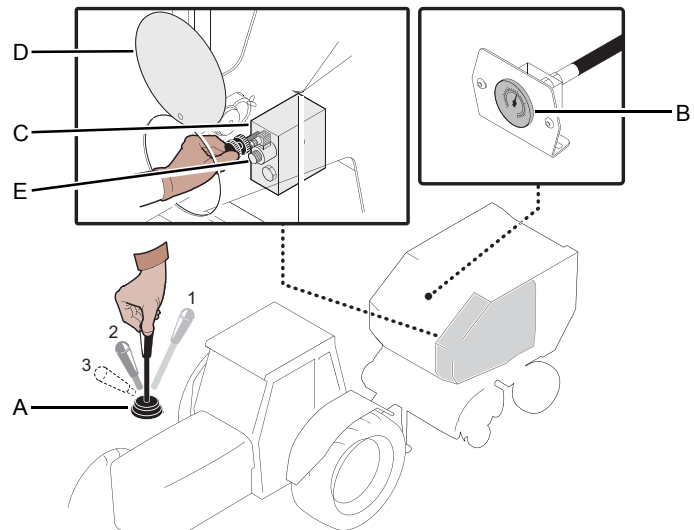

- ▶ Bring the lever (A) on the tractor's hydraulic control valve to position 1 to open the tailgate.
- ▶ Bring the lever (A) on the tractor's hydraulic control valve to position 2 to close the tailgate, and hold it in place until the pressure displayed on the pressure gauge (B) reaches the set value.
If the value on the gauge is not suitable, you will have to adjust the operating pressure of the valve (C).
- ▶ Turn off the engine, engage the parking brake, and remove the ignition key.
- ▶ To adjust the valve's operating pressure, open the door (D).

NOTICE

Since the valve is not equipped with reference notches that allow its adjustment to the selected value, the tailgate opening and closing procedures will have to be repeated in order to adjust it properly.

- ▶ Use the valve's ring nut (E) to increase or decrease the operating

Using the machine

pressure.

NOTICE

The greater the value of the set operating pressure, the greater the bale density.

If the valve's pressure is calibrated at a value that's greater than the tractor's maximum operating pressure, the pressure gauge indicates the value of the latter.

During the formation of the bale, the operating pressure may increase to a value greater than the tractor's operating pressure.

- ▶ Start the tractor's engine from the driver's seat.
- ▶ Set the minimum bale diameter value using the electronic control system. When this value is reached, the operating pressure set on the valve intervenes.

Electronic setting with "0 bar" / by-pass valve

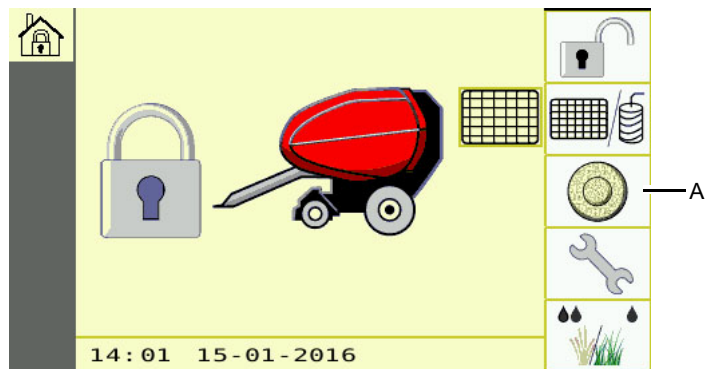

- ▶ For machines equipped with a "0 bar" / by-pass valve command, the bale density settings can be accessed by pressing the soft-key (A) on the Lock Screen page.

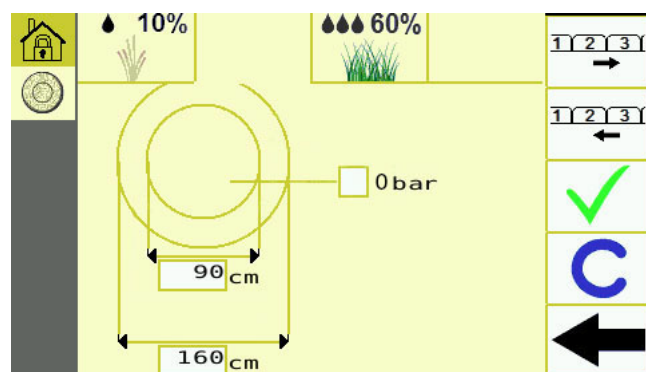

Based on the type of product and/or the user's requirements, the pressure/density in the core zone and external zone can either be activated or deactivated.

- ▶ The "0 bar" / by-pass valve allows for the production of bales with a core pressure value equal to 0 bar.
 - ▶ In order to activate or deactivate this function, press the UP/DOWN arrow buttons on the keyboard to select the "0 bar" icon, and press the OK button to confirm.

Electronic bale density setting

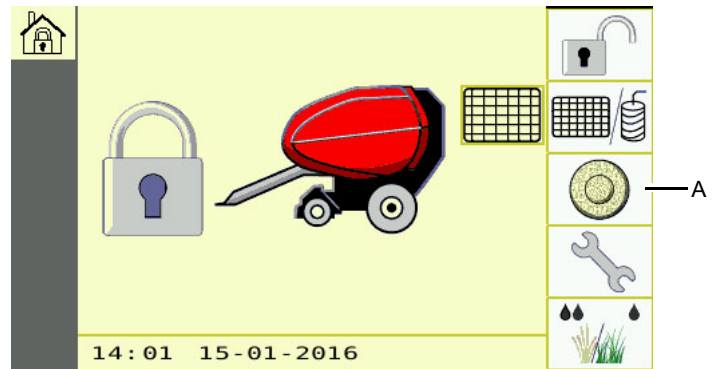

- ▶ For machines equipped with an electronic proportional valve command, the bale density settings can be accessed by pressing the soft-key (A) on the Lock Screen page.

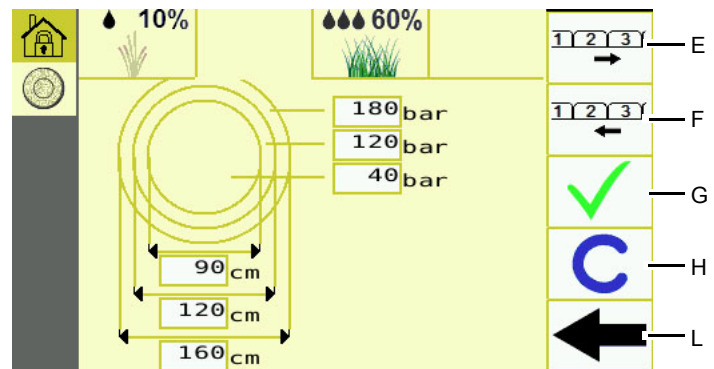

- ▶ The electronic proportional valve allows you to produce perfectly structured bales based on the crop conditions. The density and diameter of the bale's core, middle and outer sectors can be adjusted individually based on the user's preferences.
 - ▶ Press the UP/DOWN arrow buttons on the keyboard to select the diameter and the pressure for the core, the center, and the external parts of the bale box, and press the OK button to confirm.
 - ▶ Adjust using the "UP" and "DOWN" arrows.
 - ▶ Confirm each change by pressing "OK".
- ▶ The settings shown in the chart below for various crop types can be used as an indicative guide.
- ▶ Under certain conditions it may be desirable to operate with zero pressure in the core of the bale. In this case, set the pressure in box (D1) to zero (Only possible on balers equipped with a zero bar valve, which are indicated by the presence of a second solenoid valve on the baler's hydraulic block).



NOTICE

The diameter setting (D3) is the same as setting (A) on the work screen and can be modified from either screen.

- ▶ Press soft-keys (E) or (F) to switch to a different type of product.
 - ▶ Confirm the selection of the type of product by pressing soft-key

Using the machine

(G).

- ▶ Press soft-key (H) to reset the default values of the bale diameters and pressures.
- ▶ After completing the bale density settings, press the "HOME" key (L).

Bale density table (approximate reference values)

	D1 cm (in)	P1 bar (psi)	D2 cm (in)	P2 bar (psi)	D3 cm (in)	P3 bar (psi)
Straw	80 (31.5")	60 (870)	120 (47")	180 (2610)	150 (59")	180 (2610)
Hay crop	90 (35.5")	30 (435)	120 (47")	60 (870)	150 (59")	150 (2175)
Ensiled product	70 (27.5")	40 (580)	90 (35.5")	90 (1305)	120 (47")	120 (1740)

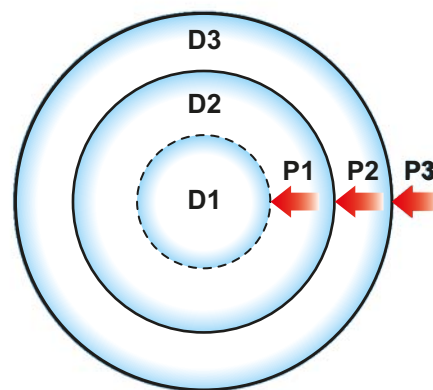

Adjusting the density in the event of an electronic control system malfunction

In the event of an electronic control system malfunction, the bale density can be manually adjusted.

To manually adjust the density of the bale, follow the indicated procedure and consult the values listed in the table.

WARNING

Make sure the tractor's PTO is disengaged. Turn off the engine, engage the parking brake, and remove the ignition key.

- ▶ Open the guard (A).
- ▶ Adjust the valve's bolt (B) and lock-nut to regulate the operating pressure.
- ▶ To increase the value of the operating pressure, turn the screw. During the machine's normal functionality (not malfunctioning), the screw (B) must be loosened to the end of its stroke (as shown in the illustration) and must not exert any pressure on the valve's internal spring.

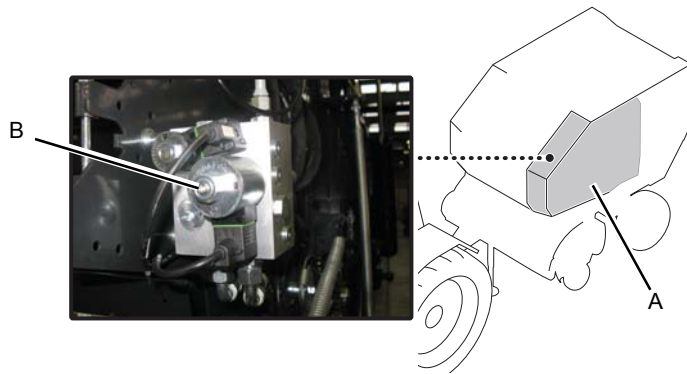

Using the machine

Field operation

When the control box is first switched on and the “WORK” screen is first displayed, “AUTO” binding will be enabled and the hydraulic selection for pick-up/drop floor/knives will be shown in the “pick-up” position.

Bale growth bar

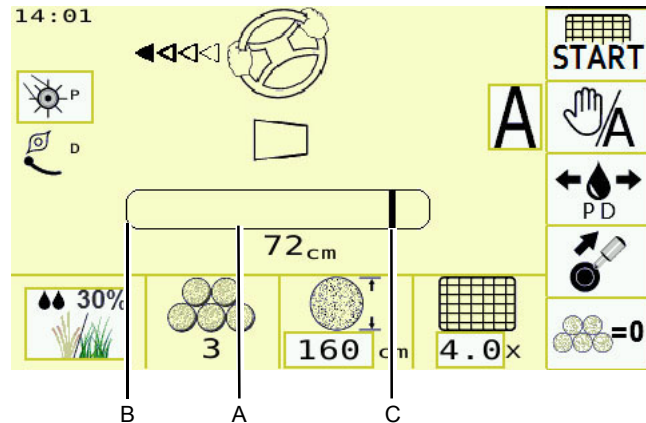

With an empty bale chamber and the tailgate pressurized and closed, the bale growth bar (A) will be empty.

- ▶ As the crop is fed into the baler and the bale starts to form, the bale growth bar will start to fill in from the left hand side (B).
- ▶ When the bale growth bar reaches the line (C), a beep will sound to indicate the bale is at 90% of its pre-set diameter.

Left/Right driving indicator

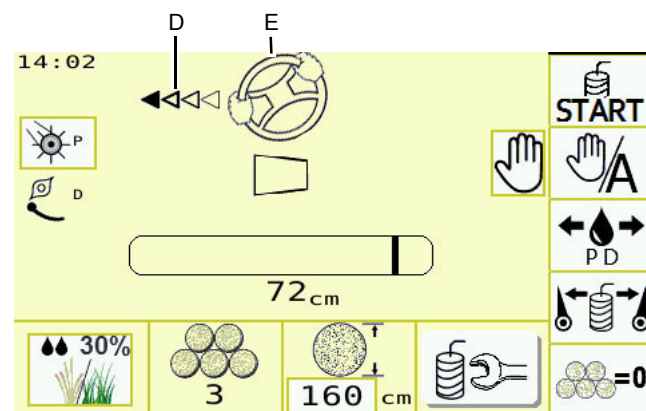

- ▶ In the event of uneven bale chamber filling at any time during the bale's formation, the driving indication arrows (D) will appear (One arrow=2.5 cm / 1"). The steering wheel (E) will also move to indicate which way to drive to properly fill the bale chamber.
- ▶ If a deviation in bale diameter of 10 cm / 4" is reached, the last arrow appears and a warning beep sounds. Under typical working conditions, the driver should switch driving directions before the fourth arrow appears, with the aim of having no arrows present once the bale is complete.

Binding

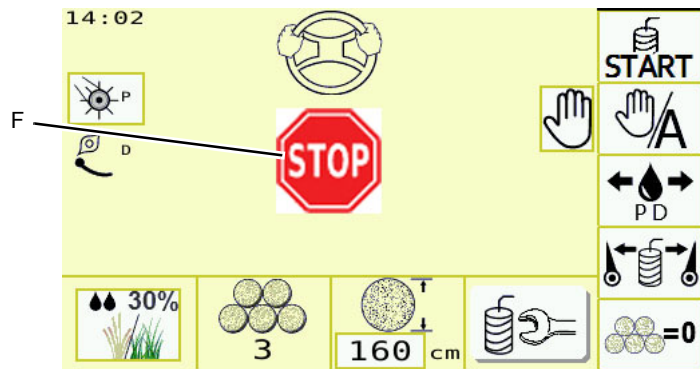

- ▶ Once the bale growth bar is completely filled, the bale growth bar will be replaced with a “STOP” signal (F). The bale is now at its pre-set diameter and is ready for binding.
- ▶ **Stop forward travel immediately.** Failure to stop could result in a layer of net or twine being inserted beneath the surface of the bale, and will result in an oversized bale.
- ▶ The binding process will start and the screen will display:

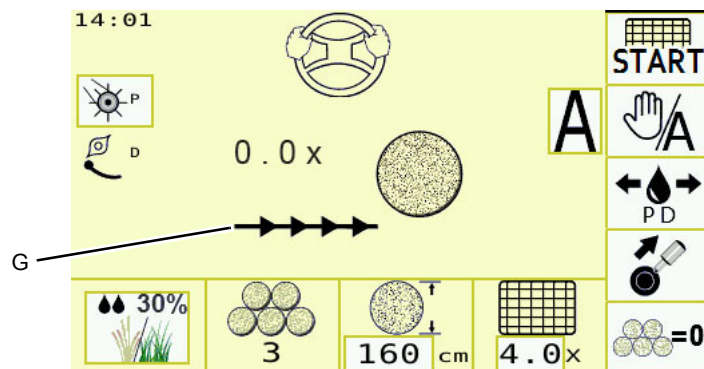

- Net binding: the screen will display the quantity of net as it is applied to the bale (G) up to the programmed number of layers.

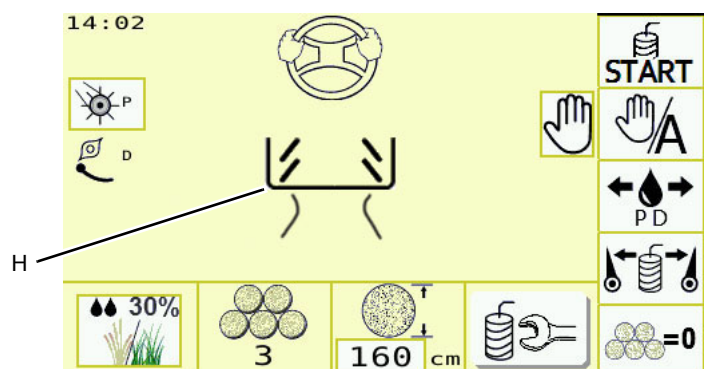

- Twine binding: the screen will display the twine reels and the relative position of the twine as it is applied to the bale (H).
- ▶ Once the binding cycle has been completed, the following screens will be displayed:

Using the machine

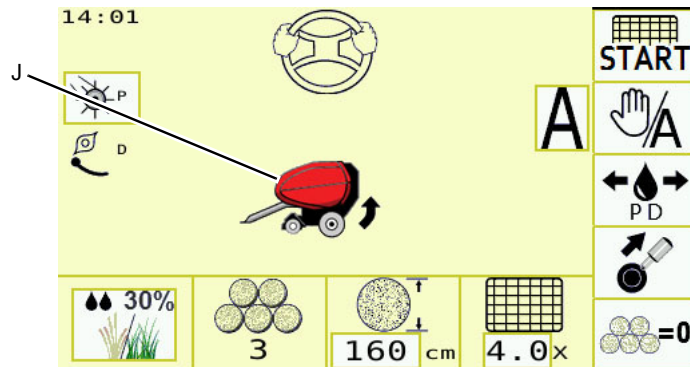

- Image of the baler with the “UP” arrow (J). Open the tailgate to unload the completed bale.

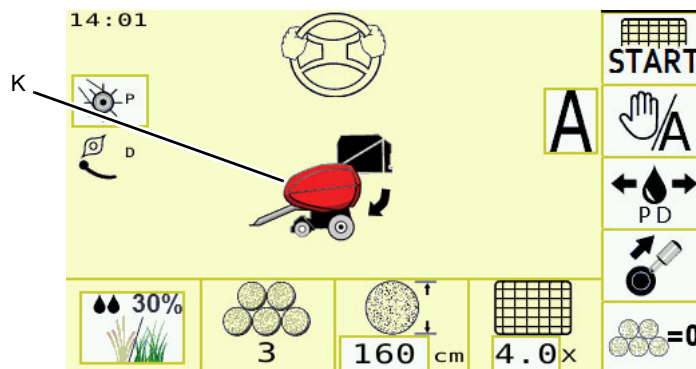

- After a delay of 4 seconds an image of the baler with “DOWN” arrow will be shown (K).



NOTICE

Make sure that the bale is not obstructing the tailgate before closing it.

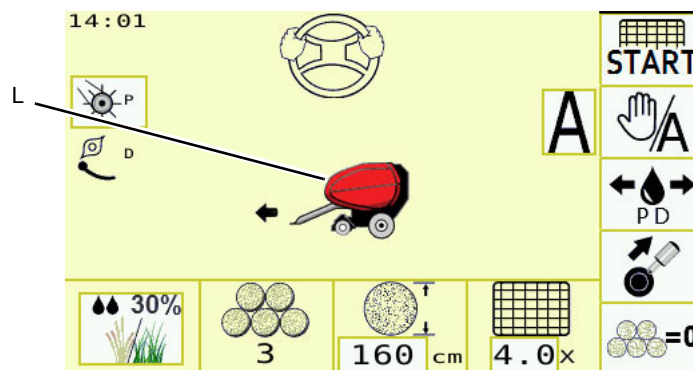

- Once the tailgate is completely closed and both sensors have received the signal, the forward arrow (L) will appear just before the bale growth bar reappears to reinitiate the bale formation process.

Manual binding cycle start

Under certain circumstances it may be necessary to start the binding cycle manually, for example when the work in the field is completed before a fully-formed bale has been produced.

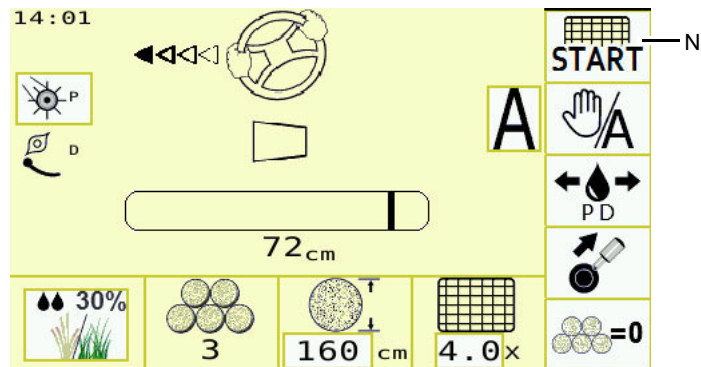

- ▶ Press the START soft-key (N).
The binding cycle starts in automatic cycle mode.

Bale formation in manual mode

It may be necessary to form the bale without automatically starting the binding cycle. This can be useful when you are completing your work activities in a field, and you would prefer to produce 1 or 2 slightly larger bales rather than end up with an excessively small bale at the end.

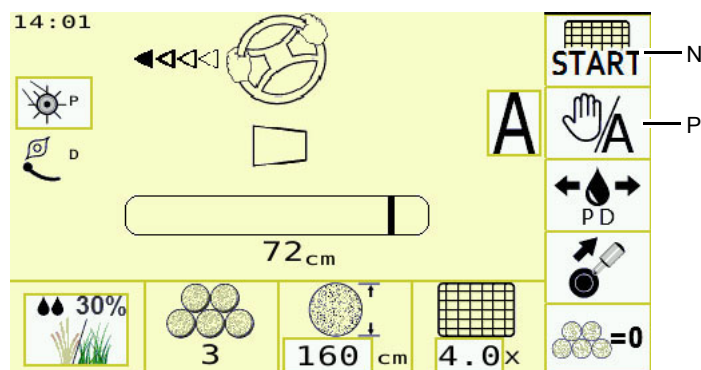

- ▶ Press the soft-key (P) at any time during the formation of the bale.
- ▶ Watch the bale growth bar and make sure that the bale does not grow to an excessive size that cannot be managed.
- ▶ When you want to initiate the binding operation, press the soft-key (N).

WARNING

Do not produce the bales in manual mode if you are already producing bales with the maximum diameter.
The failure to respect this indication could result in serious damage to the baler.

Using the machine

Using the hydraulic functions

If present, the pick-up, the Supercut knives, and the drop floor's release device are managed by a single-acting hydraulic control element located on the tractor.

Using the Pick-up

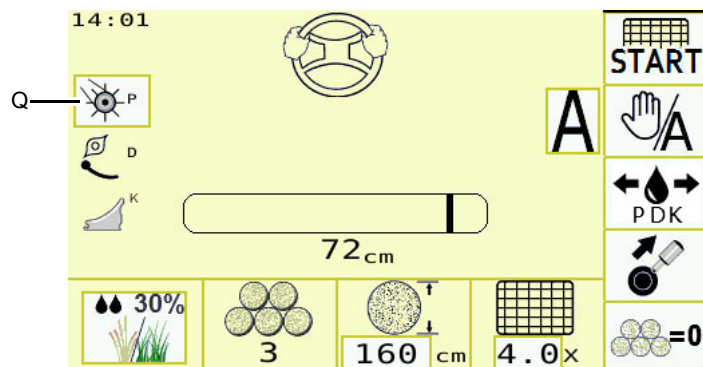

- ▶ When the work screen is selected after having activated the control system, the pick-up function is always that which is enabled. The oil droplet symbol is displayed next to the icon (Q). The activation of the tractor's valve raises and lowers the pick-up.

Using the Supercut knives

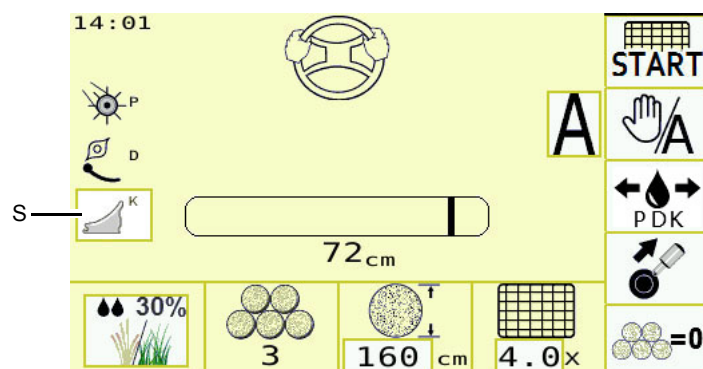

- ▶ In order to select the operating mode without the knives, select the highlighted icon (S)

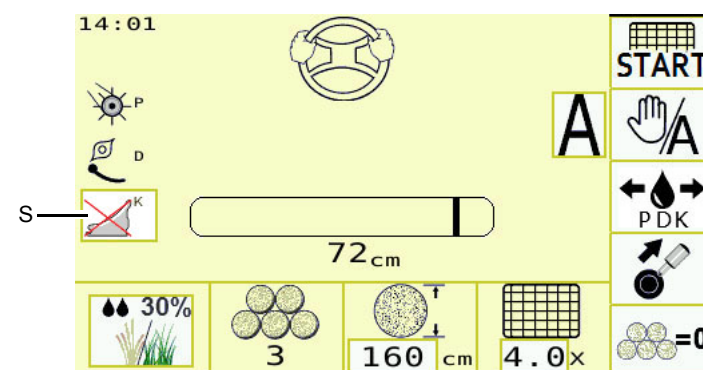

- ▶ Pressurize the tractor's valve in the same direction utilized to raise the pick-up. An X appears on the knife icon (S) in order to indicate that the knives are not connected.
- ▶ In order to reactivate the knives function, activate the tractor's valve in the opposite direction (or rather discharge the pressure). The knives are brought to their working position thanks to the pressure exerted by the spring.

Using the drop floor's release device

In the event of a feed system blockage, the drop floor device can be used to eliminate the blockage.

NOTICE

Before using the drop floor device, it is recommended to lower the Supercut knives (if in use) before using the drop floor function (proceed as indicated above).

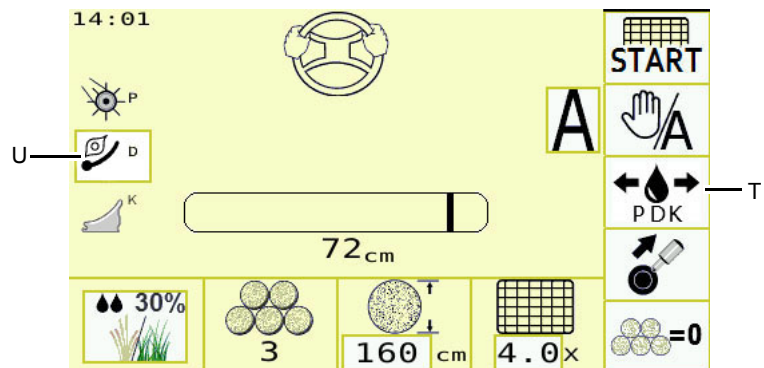

- ▶ In order to select the drop floor device function, press the soft-key (T) until the appropriate icon is highlighted (U).

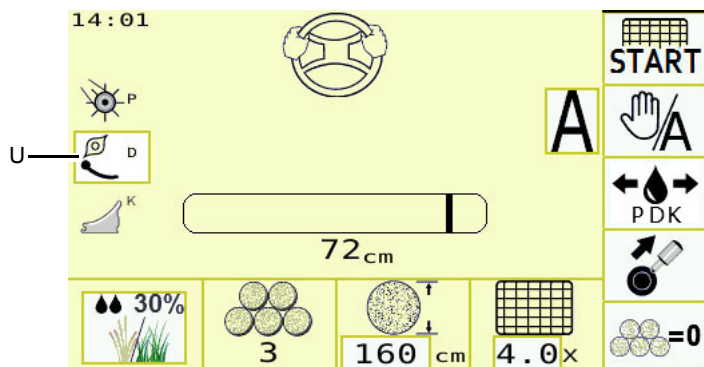

- ▶ Activate the tractor's valve in the same direction utilized to lower the pick-up. The drop floor device descends, and the drop floor icon (U) changes to indicate the lowered position and starts flashing.

NOTICE

Activate the tractor's valve for a few seconds to allow the drop floor device to open completely.

- ▶ After the reactivation of the PTO and after having removed the blockage, close the drop floor device once again by pressurizing the tractor's valve.
- ▶ Don't forget to reengage the Supercut knives (if in use).

Using the machine

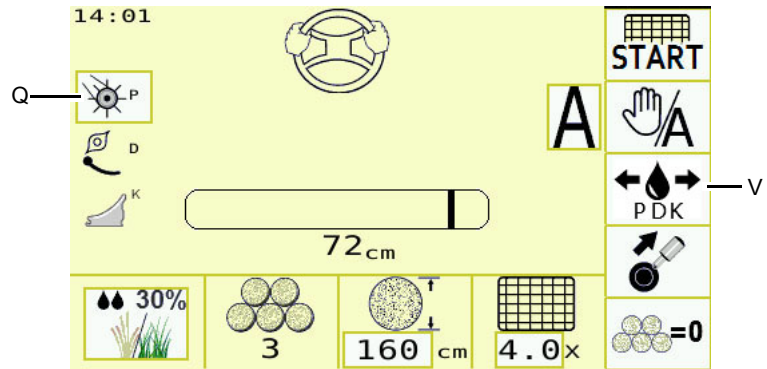

- ▶ In order to select the pick-up function, press the soft-key (V) until the appropriate icon is highlighted (Q).
- ▶

Working settings Menu

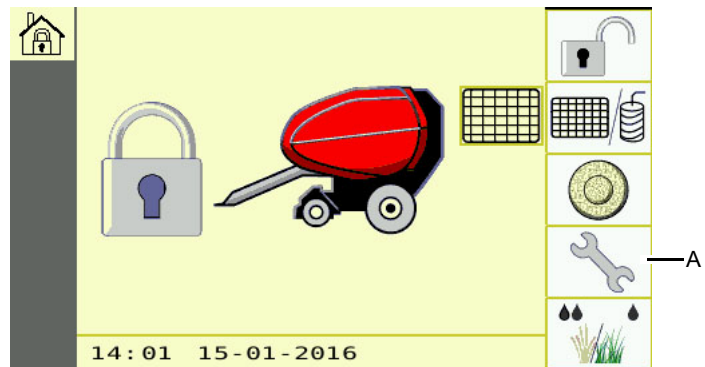

- ▶ Press soft-key (A).

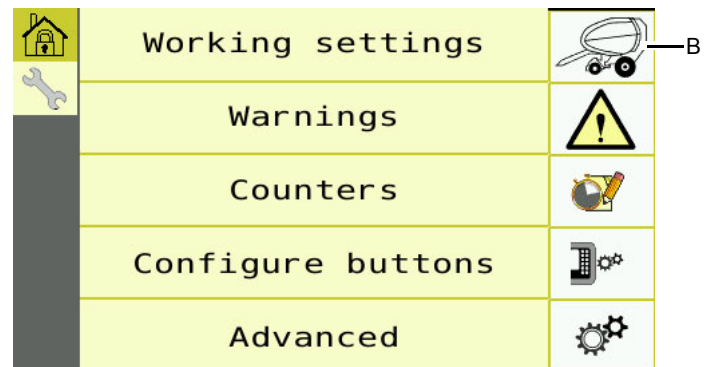

- ▶ Press soft-key (B).

The baler has various settings that can be selected based on the user's preferences.

In order to modify the settings for one of the following functions:

- ▶ Use the UP/DOWN arrow buttons to select the desired box and press the OK button to confirm.
- ▶ Adjust the quantity using the "UP" and "DOWN" arrows.
- ▶ Confirm the changes by pressing "OK".

Settings with net binding

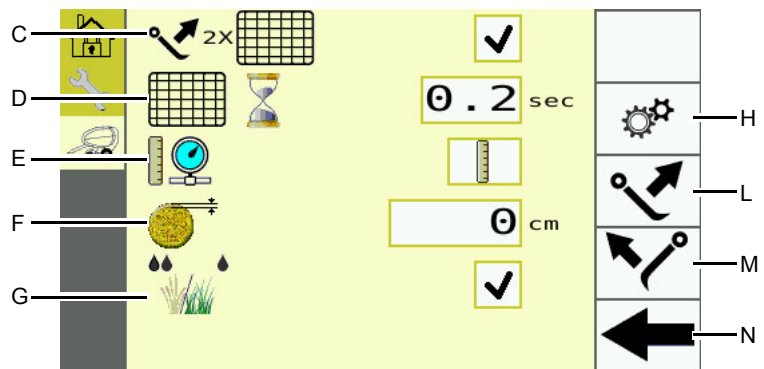

- C) **Second automatic net activation attempt**
If the net cycle is not successfully activated on the first try, this will be recognized by the system and it will automatically perform a second or third attempt.
- D) **Net activation delay after having reached the set bale size**
Normally set to 1 second.
If the bale's formation is carried out at a high advancement speed, an increase to 2 or 3 seconds could be advantageous in order to allow an increased stopping time. This prevents the crop from penetrating between the net's layers.
- E) **Change unit of measurement**
Set by default for the measurement system in use in the relative country.
To change the measurement system, press the relative soft-key and choose from the three options available; metric, imperial, US.

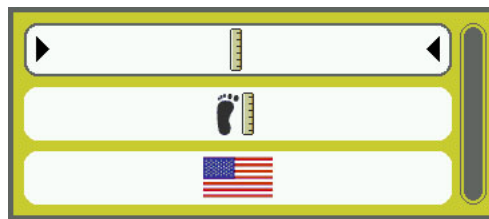

- F) **Bale diameter correction**
If the roto-baler consistently produces bales with a diameter differing from the set value, a correction value may be set to increase or decrease the diameter.

NOTICE

The diameter of the bale is subject to change based on the conditions of the crop and the expansion that takes place when the bale is released from the forming chamber. In the case of greater deviations, it may be necessary to recalibrate the bale growth sensor. In this case, please contact your dealer.

- F) **Crop option**
Enables crop type selection, with the relative density and binding mode settings.
- H) Press the soft-key to view the "Advanced Settings" menu.
- L) Press and hold to bring the net insertion assembly towards the bale forming chamber.

Using the machine

- M) Press and hold to move the net insertion assembly away from the bale forming chamber and return it to the initial work Reset position.
- N) Press to return to the previous menu.

Settings with "twine" binding

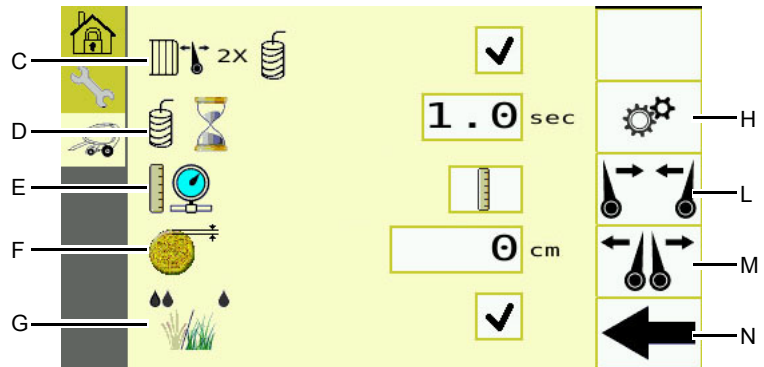

- C) **Second automatic twine activation attempt**
Activation / deactivation of the second automatic twine cycle activation attempt (only available when the twine usage sensors are present)
- D) **Twine activation delay after having reached the set bale size**
Normally set to 1 second.
If the bale's formation is carried out at a high advancement speed, an increase to 2 or 3 seconds could be advantageous in order to allow an increased stopping time. This prevents the crop from penetrating between the net's layers.
- E) **Change unit of measurement**
Set by default for the measurement system in use in the relative country.
To change the measurement system, press the relative soft-key and choose from the three options available; metric, imperial, US.

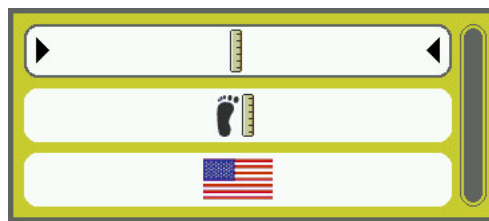

- F) **Bale diameter correction**
If the roto-baler consistently produces bales with a diameter differing from the set value, a correction value may be set to increase or decrease the diameter.

NOTICE

The diameter of the bale is subject to change based on the conditions of the crop and the expansion that takes place when the bale is released from the forming chamber. In the case of greater deviations, it may be necessary to recalibrate the bale growth sensor. In this case, please contact your dealer.

- F) **Crop option**
Enables crop type selection, with the relative density and binding mode settings.
- H) Press the soft-key to view the “Advanced Settings” menu.
- L) Press and hold to move the twine arms inward.
- M) Press and hold down to move the twine arms outward.
- N) Press to return to the previous menu.

Warnings menu

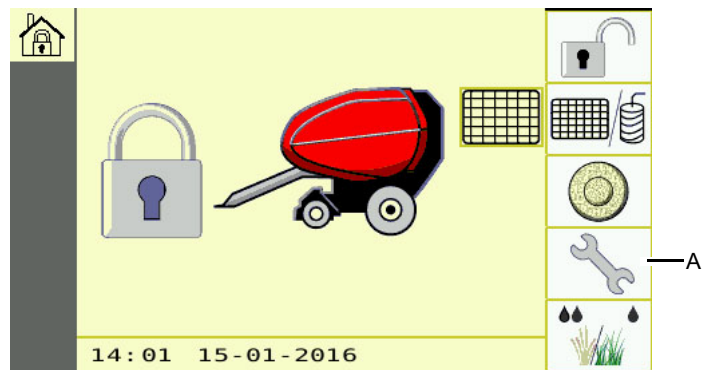

- ▶ Press soft-key (A).

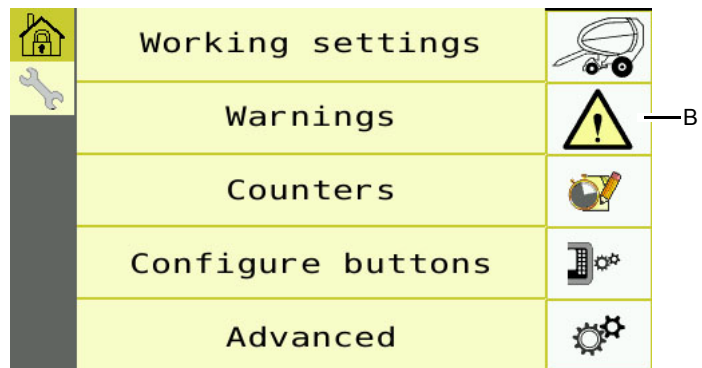

- ▶ Press soft-key (B).

Various beeps are emitted during the formation of the bale. Some of these can be deactivated based on the operator's preferences.

- ▶ Use the UP/DOWN arrow buttons to select the desired fields and press OK to confirm.
- ▶ Use the UP/DOWN arrow buttons to activate or deactivate the beeps and press OK to confirm the changes.

Using the machine

Settings with net binding

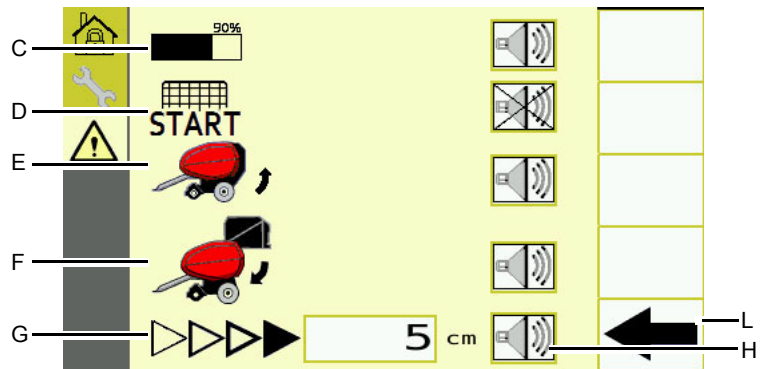

- C) Activation / deactivation of the 90% bale size acoustic signal.
- D) Activation / deactivation of the acoustic signal at the start of the net binding cycle.
- E) Activation / deactivation of the acoustic signal when the tailgate can be opened.
- E) Activation / deactivation of the acoustic signal when the tailgate can be closed.
- G) Sensitivity of the left / right indication; difference in the diameter of the bale from side to side when the four arrows are displayed (the default setting is 5-10 cm / 2"-4" per le 4ft e 20% per le 5ft).
- H) Activation / deactivation of the acoustic signal for the left / right indication.
- L) Press to return to the previous menu.

Settings with "twine" binding

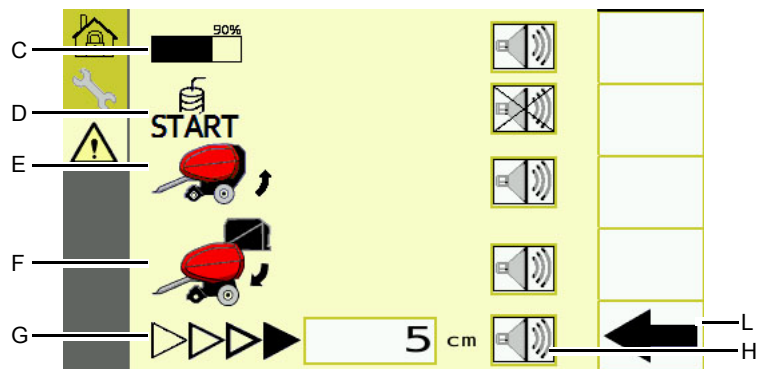

- C) Activation / deactivation of the 90% bale size acoustic signal.
- D) Activation / deactivation of the acoustic signal when the twine binding process is initiated.
- E) Activation / deactivation of the acoustic signal when the tailgate can be opened.
- E) Activation / deactivation of the acoustic signal when the tailgate can be closed.
- G) Sensitivity of the left / right indication; difference in the diameter of the bale from side to side when the four arrows are displayed (the default setting is 5-10 cm / 2"-4" per le 4ft e 20% per le 5ft).
- H) Activation / deactivation of the acoustic signal for the left / right indication.
- L) Press to return to the previous menu.

Counters Menu

The bale counter can be accessed from the setup screen.

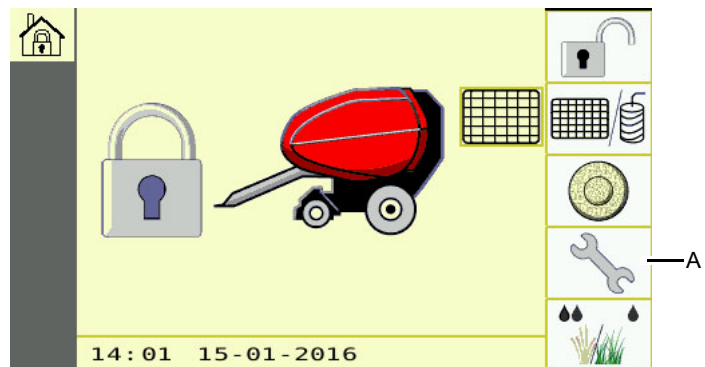

► Press soft-key (A).

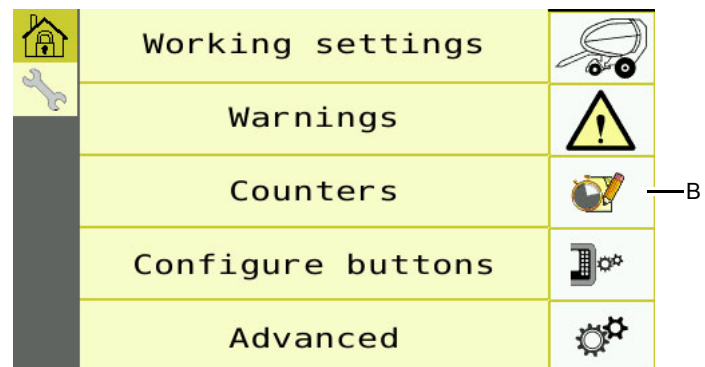

► Press soft-key (B).

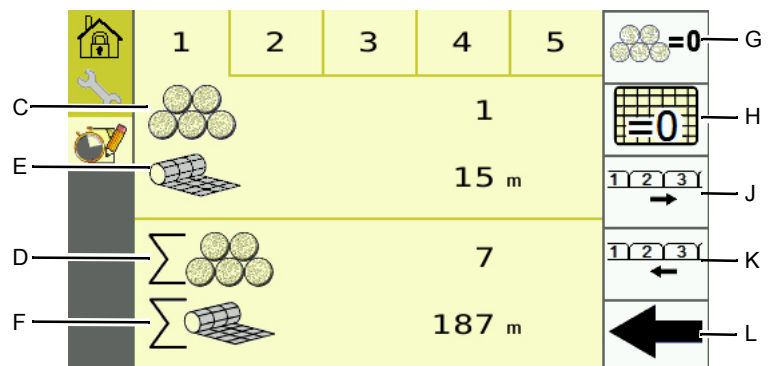

- C) Partial bale counter
- D) Total bale counter
- E) Shows the partial value of the meters/feet of net used from the net roll
- F) Shows the total meters/feet of net used from the net roll
- G) Partial bale counter reset
- H) Partial net counter reset
- J) Select the next bale counter
- K) Select the previous bale counter
- L) Press to return to the previous menu.

Using the machine

Configure Buttons menu

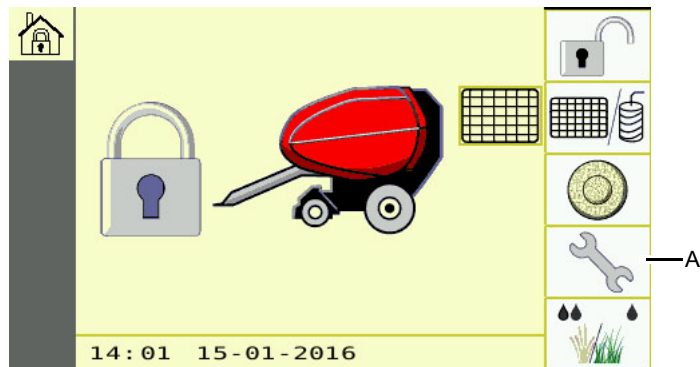

▶ Press soft-key (A).

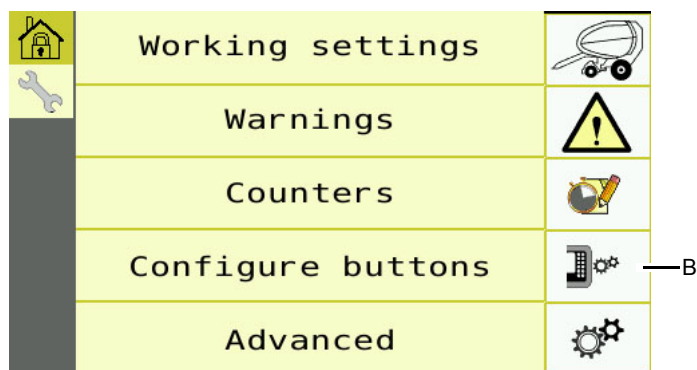

▶ Press soft-key (B).

The two soft-keys “F1 - F2” on the keyboard can be configured according to preset functions.

▶ Use the UP/DOWN arrow buttons to select the desired fields and press OK to confirm.

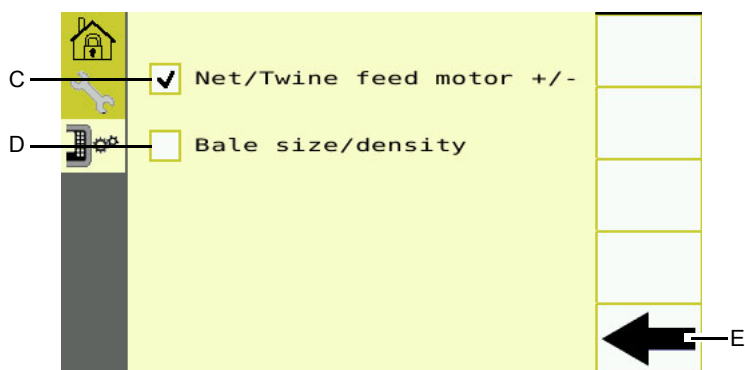

C) Press and hold down the F1-F2 buttons to make the net insertion device approach or distance itself from the bale forming chamber.

D) Press the F1-F2 buttons to change the bale's diameter/pressure.

E) Press to return to the previous menu.

Advanced Settings menu

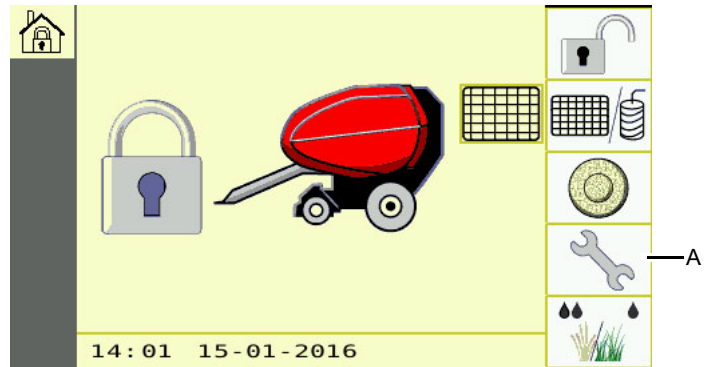

- ▶ Press soft-key (A).

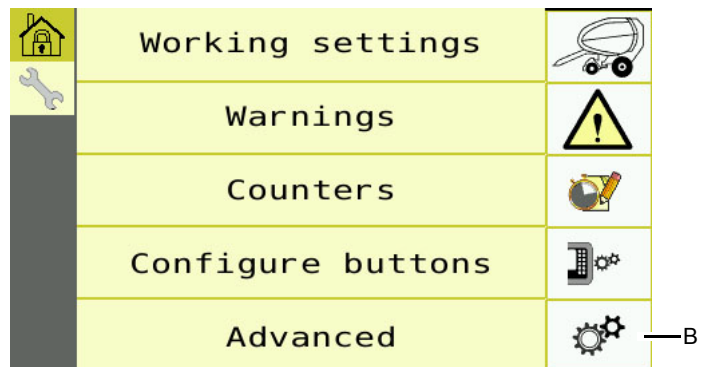

- ▶ Press soft-key (B).

This menu can be used to access the advanced work and terminal settings.

Regional settings

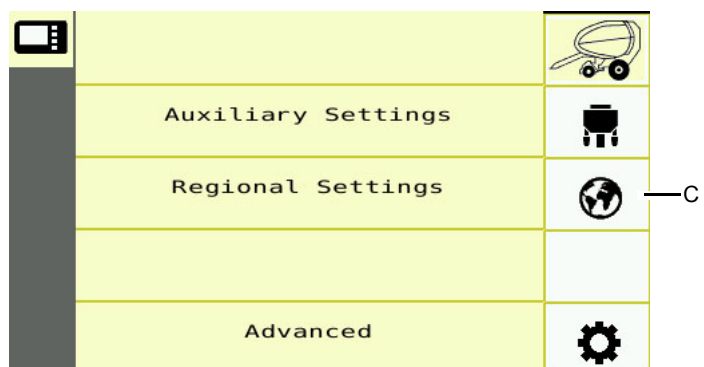

- ▶ Press soft-key (C).
 - ▶ Use the UP/DOWN arrow buttons to select the desired fields and press OK to confirm.
 - ▶ Use the UP/DOWN arrow buttons to set the values and press OK to confirm.

Using the machine

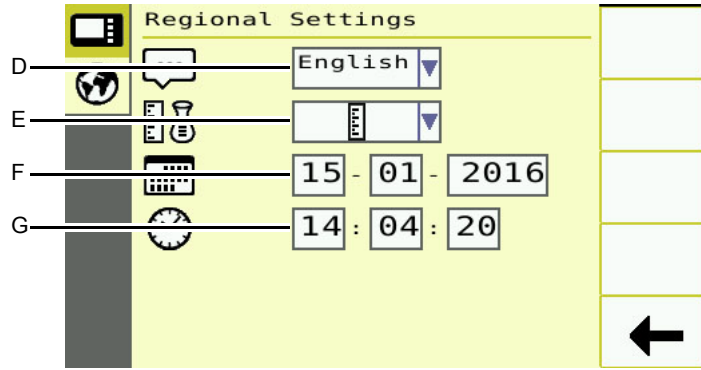

- D) Control panel language setting
- E) Control panel unit of measure setting
- F) Date setting
- G) Time setting

Equipment functionality troubleshooting

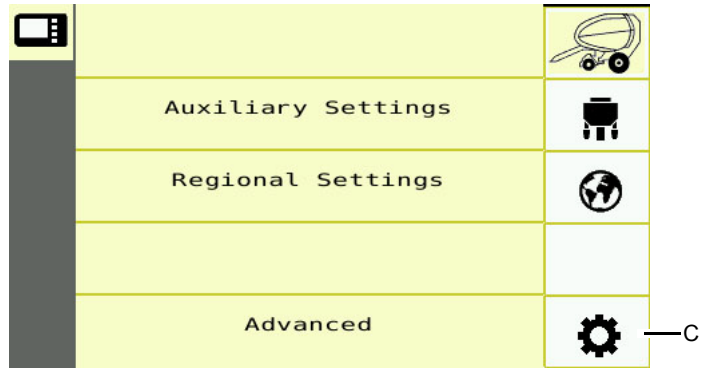

▶ Press soft-key (C).

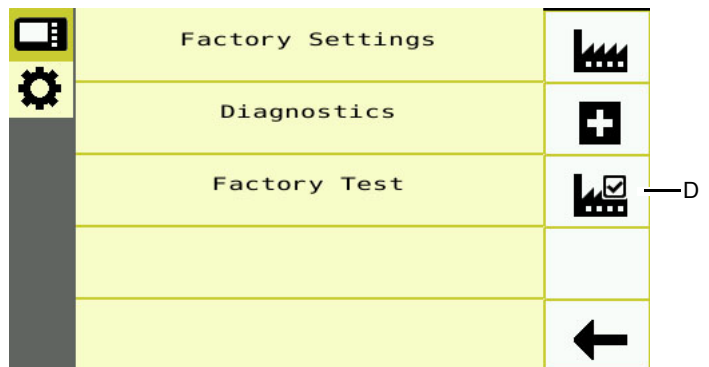

▶ Press soft-key (D).

The screen displays the equipment's layout.

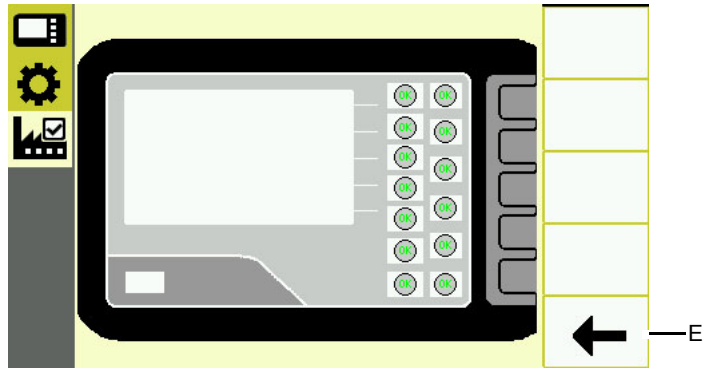

- ▶ Press the buttons on the equipment (one at a time) and check to make sure that the corresponding icon is activated on the screen (green OK).



NOTICE

In the event of a malfunction, contact the Technical Support Center authorized by the manufacturer.

Once the test has been completed, the exit button (E) is enabled to return to the previous screen.

At this point the equipment is ready for use.

Using the machine

Alarms list

- Every time the machine experiences a malfunction, an acoustic signal is emitted and an alarm message appears on the display.
- Certain malfunctions can be resolved by the operator; others require specific technical competences or particular skills, and must only be carried out by qualified personnel with recognized experience acquired within the specific sector of intervention.
- In the case of any anomalies that are not specified in the table, the operator can communicate these to the manufacturer in order to actively contribute to the development of new solutions, as well as technical and design improvements.







NOTICE

Please contact the manufacturer's Technical Support Center or an authorized workshop for any requirements you may have.







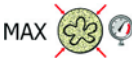
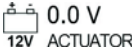
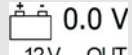
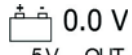

- The table indicates the messages associated with the possible malfunctions that can occur while the machine is in function, as well as the relative solutions.

no.		Alarm description	Cause	Solution
E1		Net feeding in function	The net has not been cut properly or is dragged by the bale.	Restore the net binder's proper functionality.
			The net advancement potentiometer is not properly adjusted.	Contact the Technical Support Center authorized by the manufacturer.
E2		Net feeding NOT in function	The net is broken or jammed.	Restore the net binder's proper functionality.
			The net advancement potentiometer is not properly adjusted.	Contact the Technical Support Center authorized by the manufacturer.
E3		Twine feeding in function	The twine has not been cut properly or is dragged by the bale.	Restore the twine binding unit's proper functionality.
			The twine advancement potentiometers are not properly adjusted.	Contact the Technical Support Center authorized by the manufacturer.
E4		Twine feeding NOT in function	The twine is broken or jammed.	Restore the twine binding unit's proper functionality.
			The twine advancement potentiometers are not properly adjusted.	Contact the Technical Support Center authorized by the manufacturer.
E5		Twine binding unit motor malfunction	Electric motor fault.	Replace the faulty motor or eliminate the mechanical blockages.
			The electric motor's power consumption is too high.	

Using the machine

no.		Alarm description	Cause	Solution
E7		Net cutting knife in function	The net cutting knife does not function properly.	Check the net cutting knife's proper functionality. Upon confirming the alarm message, the twine/net insertion devices return to their resting positions in order to allow the knife to reset.
E8		Net NOT cut	At the end of the binding operation, the net is not cut.	Check the net cutting knife's proper functionality.
E9		Tailgate closure hook malfunction (left side)	The bale discharge tailgate has not closed correctly.	Check the sensor's proper functionality.
				Check whether the sensor is working and replace it if necessary.
				Check the tailgate closure system's proper functionality.
E10		Tailgate closure hook malfunction (right side)	The bale discharge tailgate has not closed correctly.	Check the sensor's proper functionality.
				Check whether the sensor is working and replace it if necessary.
				Check the tailgate closure system's proper functionality.
E11		Bale diameter too large	The bale diameter is greater than the maximum permitted value.	Decrease the advancement speed.
			The potentiometer for detecting the bale diameter is not adjusted properly.	Contact the Technical Support Center authorized by the manufacturer.
E12		Bale density too high	The bale pressure is greater than the maximum permitted value.	Decrease the advancement speed.
			The bale density potentiometers are not properly adjusted.	Contact the Technical Support Center authorized by the manufacturer.
E14		"Twine/net insertion arm motor" electrical power too low	Power supply voltage insufficient (under 9 V)	Shut off the equipment. Check the functionality of the battery and the integrity of the electrical wiring.
E15		"PWR OUT" electrical voltage too low	Power supply voltage insufficient (under 9 V)	Contact the Technical Support Center authorized by the manufacturer.
E16		"5V OUT" electrical voltage too low	Power supply voltage insufficient (under 4.5 V)	Contact the Technical Support Center authorized by the manufacturer.
E17	120 °C	Electronic board overheating or overload	The electronic board's temperature is greater than 70°C	Cool down the electronic board. If the problem persists, contact to the Support Center authorized by the manufacturer.
E18	SYSTEM DEFAULT	Reset of default values	The system's default values have been reset.	Contact the Technical Support Center authorized by the manufacturer.

Using the machine

no.		Alarm description	Cause	Solution
E25		Roll brake blockage	The net coil brake is blocked.	Contact the Technical Support Center authorized by the manufacturer.
E61		Net/twine insertion device motor malfunction (movement towards the Injection position)	The electric motor's power consumption is too high.	Replace the faulty motor or eliminate the mechanical blockages.
E62		Net/twine insertion device motor malfunction (movement towards the Pre-injection position)		
E63		Net/twine insertion device motor malfunction (movement towards the Reset position)		
E64		Net/twine insertion device motor malfunction (movement towards the Injection position)	The potentiometer has not detected any movement pulses from the motor for too long.	Replace the faulty motor or eliminate the mechanical blockages.
E65		Net/twine insertion device motor malfunction (movement towards the Pre-injection position)		
E67		Net/twine insertion device motor malfunction (movement towards the Injection position)	Lack of correspondence between the theoretical position (activated by the motor) and the actual position (detected by the potentiometer).	Replace the faulty motor or eliminate the mechanical blockages.
E68		Net/twine insertion device motor malfunction (movement towards the Pre-injection position)		

Recommendations for adjustments

WARNING

Except when expressly specified, every intervention and adjustment must be performed with the PTO disengaged, the tractor's engine off, the parking brake engaged, and the ignition key removed and in the driver's possession.

WARNING

All personnel authorized to carry out adjustments must take all the necessary precautions to perform them correctly and in accordance with the current workplace safety regulations.

WARNING

Upon completing the operations, and before reactivating the machine, check to make sure that no tools, rags, or other materials have been left near the machine's moving parts or in hazardous areas.

Recommendations for maintenance

WARNING

Although the machine has been designed and manufactured to operate under harsh environmental conditions, the scheduled maintenance interventions must nevertheless be carried out regularly. Proper maintenance will ensure the machine's best possible performance, an extended service life, and constant compliance with the safety requirements.

WARNING

Before carrying out any maintenance operations, activate all the required safety devices and, if necessary, advise any other personnel working on the machine or in its vicinity. In particular, be sure to properly demarcate the surrounding areas and to prevent access to any devices that, if activated, could create unexpected hazards or risks to the health and safety of individuals.

WARNING

Except when expressly indicated, every intervention must be performed with the PTO disengaged, the tractor's engine off, and the ignition key removed and in the driver's possession. All personnel authorized to perform the aforementioned interventions must take the necessary precautions to ensure the safety of everyone involved, in full compliance with the current workplace health and safety requirements.

Maintenance and adjustments

Recommendations for parts replacements

WARNING

Except when expressly indicated, every intervention must be performed with the PTO disengaged, the tractor's engine off, and the ignition key removed and in the driver's possession. All personnel authorized to perform the aforementioned interventions must take the necessary precautions to ensure the safety of everyone involved, in full compliance with the current workplace health and safety requirements.

- Before carrying out any part replacement operations, activate all the required safety devices and, if necessary, advise any other personnel working on the machine or in its vicinity.
- If any worn components need to be replaced, only use exclusively original spare parts. The manufacturer shall bear no responsibility for any personal injuries or property damage resulting from the use of non-original spare parts and any extraordinary interventions that may have modified the safety requirements without the manufacturer's express authorization. To order spare parts, follow the instructions provided in the spare parts catalog.

Scheduled maintenance intervals chart

The chart indicates all the maintenance intervals recommended by the manufacturer in order to maintain the machine in a good work condition and to prevent the excessive wear of each individual component.

Maintenance and adjustments

 PRINT THIS PAGE AT EACH CHECK

Every 8 hours	
Machine	
Machine lubrication points	<input type="checkbox"/> Check that all of the machine's greasing points are lubricated at their specified intervals.
Transmission unit	<input type="checkbox"/> Check that the PTO shaft is correctly installed, and that all the PTO guards are undamaged and working properly.
	<input type="checkbox"/> Lubricate the PTO shaft.
Centralized lubrication system (optional)	<input type="checkbox"/> Check the oil level in the tank and top it up if necessary.
	<input type="checkbox"/> Check that all the components are undamaged and replace them with original spare parts if necessary.
Hydraulic system	<input type="checkbox"/> Check for possible oil leaks and tighten the couplings if necessary.
Tires	<input type="checkbox"/> Check the wear status and pressure of the tires.
Baling chamber	<input type="checkbox"/> Check the wear on the belts.
	<input type="checkbox"/> Check the alignment of the belts.
	<input type="checkbox"/> Check the wear on the belt joints and have them replaced if necessary.
	<input type="checkbox"/> Make sure that there is no product accumulation between the rollers and the belts, and remove any residues if necessary.
Signaling and lighting devices	<input type="checkbox"/> Check the efficiency of the light bulbs and, if necessary, remove the residues.
Cleaning the machine	<input type="checkbox"/> Clean the machine thoroughly, to free it from the accumulated product residues.
Twine binding unit (electronic)	
Transmission unit	<input type="checkbox"/> Clean with compressed air
Product feeding unit	
Feeding forks	<input type="checkbox"/> Make sure there are no product accumulations between the feeding forks and the pick-up unit and eliminate any residues if necessary.
Pick-up unit	
Reel	<input type="checkbox"/> Check that the clamps are efficient and undamaged and have them replaced if necessary.
	<input type="checkbox"/> Check that the clamps are efficient and undamaged and have them replaced if necessary.
	<input type="checkbox"/> Check that the tines are efficient and intact and have them replaced if necessary.

Maintenance and adjustments



PRINT THIS PAGE AT EACH CHECK

After 10 hours (since the first operation)	
Pick-up unit	
Auger transmission (left side)	<input type="checkbox"/> Check and, if necessary, adjust the tension of the chain.

After 20 hours (since first activation)	
Machine	
Transmission unit	<input type="checkbox"/> Check the oil level in the reducer and top it up if necessary.

Every 20 hours	
Machine	
Transmission unit	<input type="checkbox"/> Check and adjust the tension of the chains if necessary.
Closure devices for the fixed lateral guards	<input type="checkbox"/> Check their functionality and replace them if necessary.
Twine or net insertion device	<input type="checkbox"/> Clean and remove any product residues.
	<input type="checkbox"/> Carefully clean and lubricate the drive chain.
Pick-up unit	
Shock absorbers	<input type="checkbox"/> Check the pick-up unit's balance.

Maintenance and adjustments

 PRINT THIS PAGE AT EACH CHECK

Every 50 hours	
Machine	
Transmission unit	<input type="checkbox"/> Check the wear status of the pinions and chains.
Hydraulic system	<input type="checkbox"/> Check the functionality of the tailgate's opening and closing mechanism.
Towing drawbar and eyelet	<input type="checkbox"/> Make sure the main parts' fastening screws are tightened properly.
Wheel rims	<input type="checkbox"/> Check the tightening torque of the fastening screws.
Shaft with brake (optional)	<input type="checkbox"/> Lubricate the brake disk
Net binder group (electronic)	
Drive rollers and net insertion device	<input type="checkbox"/> Clean and remove any net and/or product residues.
Product feeding unit	
Shear bolt	<input type="checkbox"/> Check its functionality and replace it if necessary.
Transmission	<input type="checkbox"/> Check the transmission chain's tension.
Hydraulic system	<input type="checkbox"/> Check the integrity of all components of the chopping device (if installed) and have them replaced if necessary.
Pick-up unit	
Shear bolt	<input type="checkbox"/> Check its functionality and replace it if necessary.
Hydraulic system	<input type="checkbox"/> Check the integrity of all the pick-up unit's components and have them replaced if necessary.
Auger transmission (left side)	<input type="checkbox"/> Check and, if necessary, adjust the tension of the chain.
Pick-up unit cam	<input type="checkbox"/> Check the tightening torque of the fastening screws.
Pick-up unit closure plates	<input type="checkbox"/> Check the tightening torque of the fastening screws.

Every 100 hours	
Twine binding unit (electronic)	
Transmission unit	<input type="checkbox"/> Check and adjust the tension of the chains if necessary.
Cutting arm	<input type="checkbox"/> Check the wear status and cutting efficiency of the blade and replace it if necessary.
Pick-up unit	
Reel	<input type="checkbox"/> Check the efficiency of the bearings and have them replaced if necessary.

Maintenance and adjustments



PRINT THIS PAGE AT EACH CHECK

Every 6 months	
Product feeding unit	
Transmission	<input type="checkbox"/> Clean and remove any product residues.

Every 12 months or 10000 bales	
Machine	
Transmission unit	<input type="checkbox"/> Change the oil in the reducer.
Moving parts and machine structure	<input type="checkbox"/> Check the wear status of the bearings and replace them with original spare parts if necessary.
	<input type="checkbox"/> Make sure the main parts' fastening screws are tightened properly.
Shaft with brake (optional)	<input type="checkbox"/> Lubricate the brake arm
Net binder group	
Cutting device	<input type="checkbox"/> Check the wear status and cutting efficiency of the blades and have them replaced if necessary.
Pick-up unit	
Reel	<input type="checkbox"/> Check the efficiency of the cams and have them replaced if necessary.

At the end of the season	
Twine binding unit (electronic)	
Transmission unit	<input type="checkbox"/> Clean and lubricate.

Maintenance and adjustments

Lubricant table

Important

Use oils and lubricants with characteristics identical to those specified in the chart.

Specifications	Parts to lubricate	Quantity	
SAE J-2360 (SAE 80W-90) example: KUBOTA Heavy Duty 80W-90 Gear Oil	Reducer	2.3 lt	Rotor - Supercut
ROTRA JD F85 example: KUBOTA Super UDT	Hydraulic system	5.0 lt	
DIN 51524-2 (OSO 32 - 46 - 68) example: KUBOTA Ultractive Hydraulic Oil 46	Automatic lubrication system	4.2 lt	
NLGI 1/2 ISO L-X-BEHB 1/2 example: KUBOTA Polyurea Grease	Grease nipples and bearings	-	
NLGI 1 ISO L-X-BCHB 1	Greasing point	-	

Maintenance and adjustments

Tightening torque table

Check all the fastening elements of the machine's various components with a torque spanner. Respect the torque values indicated in the table..



CAUTION

Replace any fastening elements that have deteriorated.



NOTICE

These values were obtained experimentally, and for serial applications it is recommended to check them by conducting field tests.

Classe di resistenza	8.8						10.9						12.9		
Materiale	SS400, S20C						S43C, S48C						SCr435, SCM435		
Tipo di filettatura	Filettatura a passo "grosso"			Filettatura a passo "fine"			Filettatura a passo "grosso"			Filettatura a passo "fine"			Filettatura a passo "grosso"		
Unità di misura Diametro	N-m	kgf-m	ft-lbs	N-m	kgf-m	ft-lbs	N-m	kgf-m	ft-lbs	N-m	kgf-m	ft-lbs	N-m	kgf-m	ft-lbs
M6 (6 mm, 0.24 in.)	8.5	0.9	5.8				12	1.2	8.3				14	1.4	9.7
	+ 10	+ 0.1	+ 6.9				+ 15	+ 1.5	+ 10.4				+ 18	+ 1.8	+ 12.5
M8 (8 mm, 0.31 in.)	20	2.0	13.8	22	2.2	15.2	29	2.9	20.1	31	3.2	21.5	34	3.4	23.5
	+ 25	+ 2.5	+ 17.3	+ 27	+ 2.7	+ 18.7	+ 35	+ 3.5	+ 24.2	+ 38	+ 3.9	+ 26.3	+ 42	+ 4.3	+ 29.1
M10 (10 mm, 0.39 in.)	40	4.1	27.7	42	4.3	29.1	57	5.8	39.5	59	6.0	40.8	68	6.9	47.1
	+ 50	+ 5.1	+ 34.6	+ 53	+ 5.4	+ 36.7	+ 70	+ 7.1	+ 48.5	+ 74	+ 7.5	+ 51.2	+ 84	+ 8.6	+ 58.1
M12 (12 mm, 0.47 in.)	69	7.0	47.8	72	7.3	49.8	97	9.9	67.1	101	10.3	69.9	116	11.8	80.3
	+ 85	+ 8.7	+ 58.8	+ 89	+ 9.1	+ 61.6	+ 119	+ 12.1	+ 82.4	+ 125	+ 12.7	+ 86.5	+ 143	+ 14.6	+ 99
M14 (14 mm, 0.55 in.)	110	11.2	76.1	118	12.0	81.7	154	15.7	106.6	166	16.9	114.9	185	18.8	128
	+ 135	+ 13.8	+ 93.4	+ 148	+ 15.1	+ 102.5	+ 190	+ 19.3	+ 131.5	+ 208	+ 21.2	+ 144	+ 228	+ 23.2	+ 157.8
M16 (16 mm, 0.63 in.)	128	13.1	88.6	180	18.4	124.6	240	24.5	166.1	253	25.8	175.1	287	29.3	198.7
	+ 216	+ 22.0	+ 149.5	+ 226	+ 23.1	+ 156.4	+ 298	+ 30.4	+ 206.3	+ 318	+ 32.4	+ 220.1	+ 357	+ 36.4	+ 247.1
M18 (18 mm, 0.71 in.)	235	24.0	162.7	248	25.3	171.3	330	33.7	228.4	349	35.6	241.6	397	40.5	274.8
	+ 290	+ 29.6	+ 200.8	+ 310	+ 31.6	+ 214.6	+ 402	+ 41.2	+ 278.3	+ 436	+ 44.5	+ 301.8	+ 490	+ 50	+ 339.2
M20 (20 mm, 0.78 in.)	332	33.9	229.8	347	35.4	240.2	467	47.6	323.3	489	49.9	338.5	561	57.2	388.4
	+ 413	+ 42.1	+ 285.9	+ 436	+ 44.5	+ 301.8	+ 580	+ 59.2	+ 401.5	+ 614	+ 62.6	+ 425	+ 697	+ 71.2	+ 482.5
M22 (22 mm, 0.86 in.)	454	46.3	314.3	474	48.4	328.1	639	65.2	442.4	666	67.9	461.1	767	78.2	531
	+ 568	+ 57.9	+ 393.2	+ 597	+ 60.9	+ 413.3	+ 798	+ 81.4	+ 552.5	+ 840	+ 85.7	+ 581.5	+ 958	+ 97.7	+ 663.2
M24 (24 mm, 0.94 in.)	574	58.6	397.4	617	62.9	427.1	808	82.4	559.4	868	88.5	600.9	969	98.2	670.8
	+ 714	+ 72.8	+ 494.3	+ 781	+ 79.7	+ 540.7	+ 1004	+ 102.4	+ 695.1	+ 1098	+ 112	+ 760.1	+ 1204	+ 122.8	+ 833.5
M27 (27 mm, 1.06 in.)	840	85.7	581.5	897	91.5	621	1181	120.5	817.6	1261	128.7	873	1418	144.6	981.7
	+ 1050	+ 107.1	+ 726.9	+ 1139	+ 116.2	+ 788.5	+ 1477	+ 150.7	+ 1022.5	+ 1602	+ 163.5	+ 1109.1	+ 1772	+ 180.8	+ 1226.7
M30 (30 mm, 1.18 in.)	1146	116.9	793.4	1248	127.3	864	1611	164.4	1115.3	1754	178.9	1214.3	1993	197.2	1338.2
	+ 1429	+ 145.8	+ 989.3	+ 1590	+ 162.2	+ 1100.8	+ 2009	+ 205	+ 1387.4	+ 2236	+ 228.1	+ 1548	+ 2411	+ 246	+ 1669.1

Lubrication points diagram



WARNING

Make sure the tractor's PTO is disengaged.
Turn off the engine, engage the parking brake, and remove the ignition key.

Lubricate the parts at the points and at the intervals specified.



NOTICE

Before lubricating, thoroughly clean the parts involved and the greasers to prevent any impurities from mixing with the lubricant.

Maintenance and adjustments

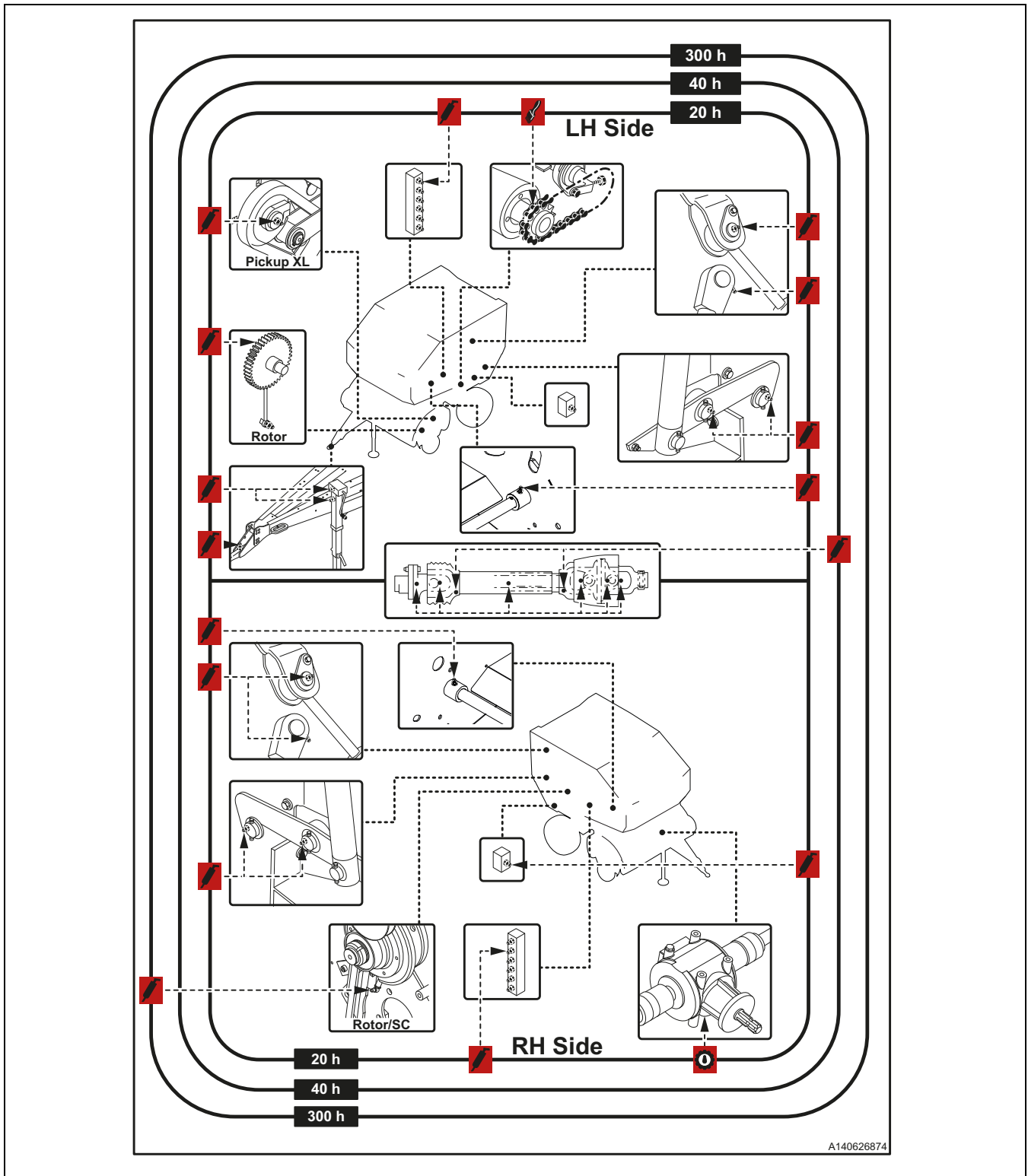

Maintenance and adjustments

Lubrication of shaft with brake (optional)

In the machines equipped with a shaft with brake (optional), it is necessary to lubricate the shaft, in addition to the machine components.

Refer to the figures below to perform this operation.

Lubrication of brake disc

NOTICE

Lubricate the brake disc every 50 hours of operation.

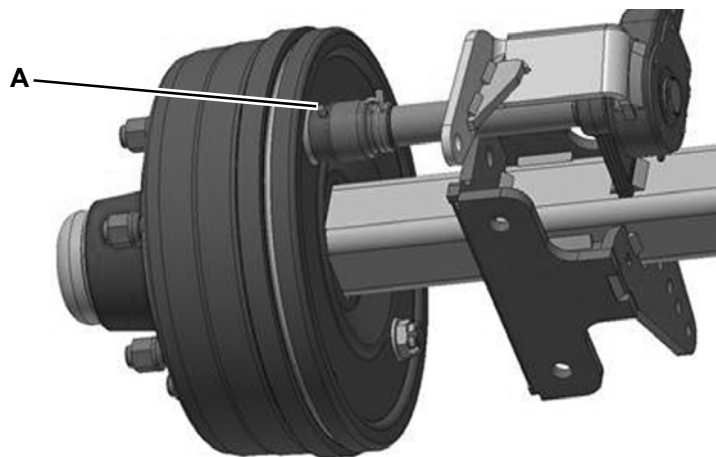

Lubrication of brake lever

NOTICE

Lubricate the brake lever every 12 months of operation.

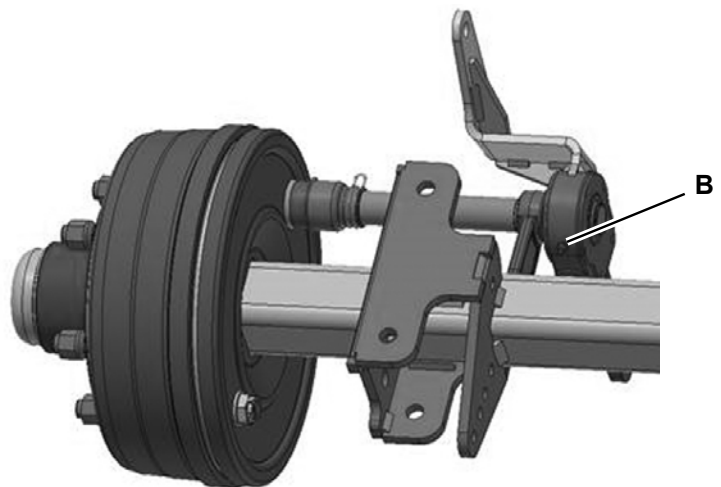

Maintenance and adjustments

Cleaning the machine

It is recommended to thoroughly clean the machine at the end of each work day or work shift.

CAUTION

Perform the machine cleaning operations with the engine off and under safe shutdown conditions.

In order to properly clean the machine, follow the instructions below.

- Cover all the electrical and hydraulic connections with the appropriate plugs.
- Do not aim high-pressure jets of water at the rotating parts, bearings, hydraulic valves, or the electrical control unit.
- Don't use any solvents or aggressive products that could deteriorate the machine's painted surfaces, hydraulic hoses, or rubber parts and seals.
- After washing, grease all parts of the machine that require it (see the lubrication points diagram).

Extraordinary maintenance

WARNING

Although the machine has been designed and built to operate under harsh environmental conditions, extraordinary maintenance interventions must be carried out after a few years in order to ensure its continued proper functionality and general safety.

WARNING

These interventions must be performed by personnel with specific technical skills at workshops that are properly equipped and authorized by the manufacturer.

WARNING

The flexible hoses in the hydraulic system must be replaced every 6 years from the date of production, or earlier if signs of wear or degradation are encountered. These components are subject to stress due to aging.

Problems - Causes - Solutions

- The purpose of the following information is to identify and correct any possible operational issues that may be encountered when using the machine.
- The various anomalies that may be encountered have been divided into tables, based on the operating units in question. It is recommended to examine all the tables in order to acquire a more in depth knowledge of all the possible anomalies.
- In the case of any anomalies that are not specified in the table, the operator can communicate these to the manufacturer in order to actively contribute to the development of new solutions, as well as technical and design improvements.
- Certain malfunctions can be resolved by the operator; others require specific technical competences or particular skills, and must only be carried out by qualified personnel with recognized experience acquired within the specific sector of intervention.
- For any requirements you may have, please contact the manufacturer's After-Sales Service, your local dealer, or an authorized workshop.

Troubleshooting table

Product defects

Problem	Cause	Solution
Light bale.	The windrow was not prepared correctly.	Correct the preparation of the windrow.
	The advancement speed is too high.	Reduce the advancement speed.
	The PTO's rotation speed is too low.	Increase the PTO's speed to 540 rpm.
	The path of the forward movement is not correct.	Modify the tractor's path.
	The bale's density pressure is insufficient.	Increase the set pressure.
	Presence of air inside the bale density hydraulic circuit.	Bleed the air from the circuit.
Bale too heavy.	The windrow was not prepared correctly.	Correct the preparation of the windrow.
	The forward movement speed is too low.	Increase the speed of the forward movement.
	Bale density pressure too high.	Reduce the set pressure.
	Product humidity percentage too high.	Reduce the humidity percentage.
Conical bale.	The forward movement path is not correct: excessive feeding on one side.	Modify the tractor's path.

Malfunction information

Problem	Cause	Solution
Barrel-shaped bale.	The forward movement path is not correct: excessive feeding at the center.	Modify the tractor's path in order to feed more crop to the edge of the bale.
Surface of the bale with rolled and chopped product.	The product is too dry.	Pick up the product when cooler.
	Bale density pressure too high.	Reduce the set pressure.
	The PTO's rotation speed is too high.	Reduce the PTO's speed.
The bale created with twine binding breaks apart.	The product is too dry.	Pick up the product when cooler. Perform the binding operation with the net binding unit (if installed).
	Bale density pressure too high.	Reduce the set pressure.
	The PTO's rotation speed is too high.	Reduce the PTO's speed.

Machine malfunctions

Problem	Cause	Solution
The machine gets clogged.	Windrow too big or irregular.	Correct the windrow size.
	The advancement speed is too high.	Reduce the advancement speed.
	The path of the forward movement is not correct.	Modify the tractor's path.
	The PTO's rotation speed is too low.	Increase the PTO's speed to 540 rpm.
	The baffle plate is not adjusted correctly.	Lower the position of the baffle plate.
The tailgate does not close correctly.	Product debris between the fixed part of the machine and the tailgate.	Remove the product debris from the baling chamber.
	The side hooks are not coupled to tailgate's side rollers.	After the tailgate has closed, wait for the hooks to close before releasing the hydraulic control. Avoid counter-pressures on the hydraulic circuit that could activate the hydraulic cylinders.
As soon as the pressurization and closing operations have ended, the tailgate's hooks accidentally disconnect.	There is residual pressure within the hydraulic oil circuit's tank return line.	Connect the return hose to an element on the tractor's hydraulic control valve (floating position).
Excessive transmission noise.	The chains are not adjusted correctly.	Adjust the chain tension.

Malfunction information

Problem	Cause	Solution
During the unloading phase, with a machine equipped with a kicker, the bale remains inside the baling chamber.	The bale kicker's roller is not positioned correctly.	Position of the roller in the first hole of the bale kicker.
The augers do not operate correctly.	Windrow too narrow.	Modify the tractor's path with movements to the right and left.
The belts do not work correctly and their duration is limited.	The path of the forward movement is not correct.	Modify the tractor's path.
	The guide rollers are not positioned correctly.	Adjust the position of the rollers.
	Accumulation of product and/or twine on the rollers.	Remove the accumulated material.
	The windrow was not prepared correctly.	Correct the preparation of the windrow.
	Product humidity percentage too high.	Reduce the humidity percentage.
	Irregular and excessive elongation of certain belts.	Make sure all the belts are of uniform length.

Pick-up unit malfunctions

Problem	Cause	Solution
Irregular product pick-up.	Pick-up unit too high.	Adjust the position of the wheels on the pick-up unit.
	The balance is not correct.	Adjust the suspension springs.
	The baffle plate is not adjusted correctly.	Adjust the position of the baffle plate.

Net binding unit malfunctions

Problem	Cause	Solution
The net is excessively stretched during bale winding.	The net reel is not assembled correctly.	Assemble the net reel in accordance with the correct procedure.
	The reel brake is not adjusted correctly.	Adjust the reel brake.
	The net's mesh is too large.	Use a suitable net reel.
The cutting device is not reset when the tailgate opens.	The reset device is not adjusted correctly.	Adjust the reset device.

Malfunction information

Twine binding unit malfunctions

Problem	Cause	Solution
During twine binding operations, the twine comes out from the side of the bale.	A barrel-shaped bale is caused by an incorrect forward movement path, with excessive feeding at the center.	Modify the tractor's path in order to feed more crop to the edge of the bale.
	The product is too dry.	Pick up the product when cooler.
	Bale density pressure too high.	Reduce the set pressure.
	The twine is not tightened sufficiently.	Adjust the twine tightening clamps.
	The twine is applied too close to edge of the bale.	Adjust the twine's position on the bale.
The twine guide arms are not positioned correctly.	The transmission chain is dirty.	Clean with compressed air and reposition the right hand twine guide arm.
	The transmission chain is worn.	Have the potentiometer replaced by the nearest authorized Technical Support Center.
	Faulty potentiometer.	Have the potentiometer replaced by the nearest authorized Technical Support Center.
The twine guide arms do not move.	Blown fuse.	Replace the fuse.
	Damaged electric motor.	Have the motor repaired or replaced by the nearest authorized Technical Support Center.
One or both strings of twine are not drawn by the bale at the start of the binding operation.	The twine is not threaded into the system correctly.	Assemble the twine routing according to the correct path.
	Twine braking is excessive.	Adjust the twine tightening clamps.
	The twine does not come out of the twine guide arm sufficiently.	Make the twine come out of the twine guide arm about 25-30 cm (9.84"-11.81").
	The binding element's insertion unit isn't working.	Check and contact a Technical Support Center authorized by the Manufacturer.
	The machine has run out of twine reels.	Refill the twine compartment with reels of twine.

Malfunction information

Problem	Cause	Solution
Twine binding is not carried out.	The machine has run out of twine reels.	Refill the twine compartment with reels of twine.
	The knot that joins the twine reels was not carried out correctly.	Check the joint knots and tie them again if necessary.
	Cutting arm not adjusted correctly.	Check and contact a Technical Support Center authorized by the Manufacturer.
	Twine braking is excessive.	Adjust the twine tightening clamps.
One or both strings of twine break during the binding phase.	Cutting arm not adjusted correctly.	Check and contact a Technical Support Center authorized by the Manufacturer.
	Twine braking is excessive.	Adjust the twine tightening clamps.
The twine is not cut correctly.	Cutting blades worn.	Sharpen the blades or replace them.  CAUTION Wear protective gloves for this operation.
	Cutting arm not adjusted correctly.	Check and contact a Technical Support Center authorized by the Manufacturer.
	Product accumulation in the cutting arm.	Remove the accumulated material.
	The springs that act upon the clamps during the final binding phase do not exert sufficient pressure.	Replace the springs.
The twine guide arms get stuck.	Faulty potentiometer.	Have the potentiometer replaced by the nearest Technical Support Center.
	The PTO's rotation speed is too low.	Increase the PTO's speed to 540 rpm.

Malfunction information

Page intentionally left blank

General maintenance of the machine

Opening the guards

WARNING

Make sure the tractor's PTO is disengaged.
Turn off the engine, engage the parking brake, and remove the ignition key.

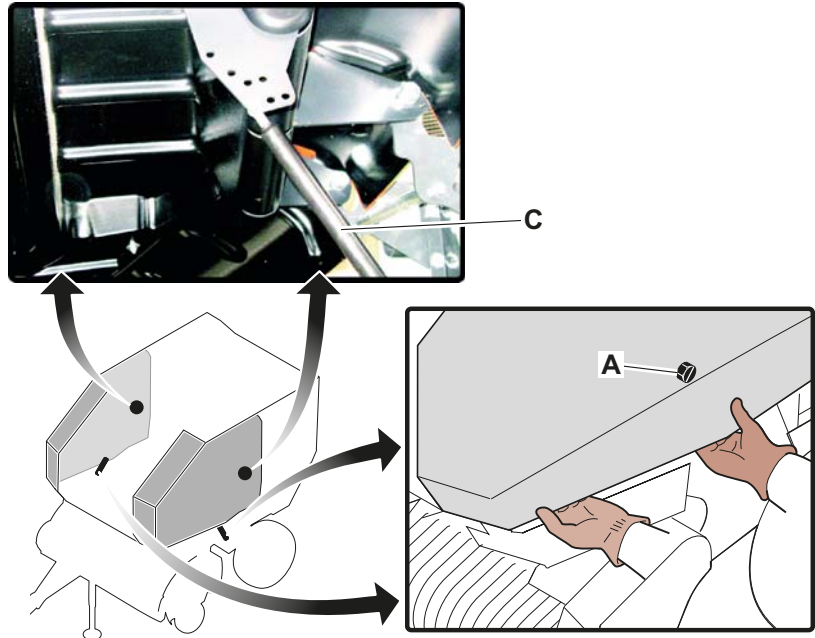

- ▶ Using an appropriate tool, release the guard from the connection device (A).

NOTICE

Adjust the position of the gas spring (C) if the guard's opening height needs to be modified.

- ▶ In order to perform the closure operation, lower the guard until it hooks on to the appropriate locking devices (proper closure is obtained when you hear the mechanical click, and when the guards remain locked in place even should you attempt to pull on them manually).

WARNING

Before using the machine, make sure that the guards are perfectly installed and that both locking devices are properly connected.

General maintenance of the machine

Checking the safety screws' tightening torque

- The figure shows the screws whose tightening torque must be regularly checked.
(if present on the machine)



NOTICE

Use a torque spanner to tighten the screws to the recommended torque value (See "Tightening torque table").

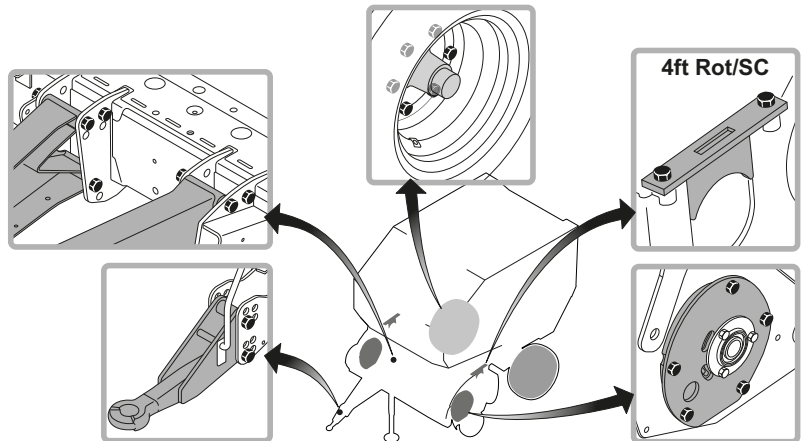

Changing the reducer oil



WARNING

Make sure the tractor's PTO is disengaged.
Turn off the engine, engage the parking brake, and remove the ignition key.

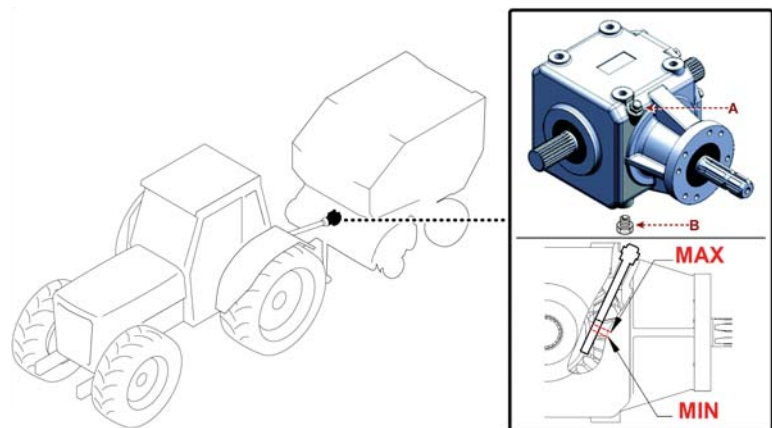

- ▶ Prepare a container with suitable capacity.
- ▶ Unscrew the filler cap (A).
- ▶ Unscrew the drain plug (B) and drain the oil completely into the container.
- ▶ Replace the drain plug (B).
- ▶ Introduce the fresh oil through the filling cap (A)
- ▶ Tighten the filling cap (A).
- ▶ Unscrew filling cap (A) and check the oil level on the indicator. If

General maintenance of the machine

necessary, top up to the maximum level shown by the reference mark.

- ▶ Re-tighten the filler plug (A) and check for leaks.

! NOTICE

Use oils with characteristics identical to those specified in the "Lubricant table".

! CAUTION

Do not disperse pollutant materials into the environment. Dispose of them in compliance with the relevant legislation in force.

Adjusting the transmission chains

! WARNING

Make sure the tractor's PTO is disengaged. Turn off the engine, engage the parking brake, and remove the ignition key.

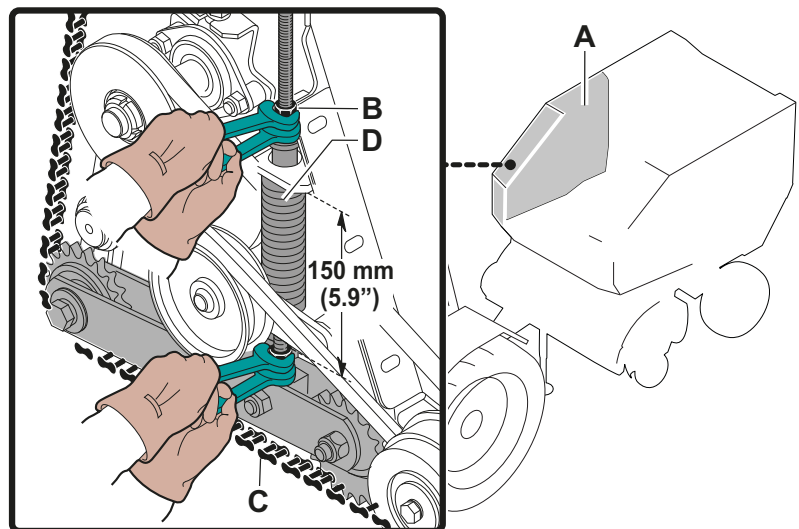

- ▶ Open the guard (A).
- ▶ If the chains are tensioned correctly, the length of the spring (D) will be equal to 150 mm (5.9").
- ▶ Adjust the length of the spring (and consequently tension of the chain (C)) by adjusting the nuts (B) and locknuts.
- ▶ Close the guard (A).

General maintenance of the machine

Adjusting the centralized lubrication system (if present on the machine)

The oil flow to the individual outlets can be independently adjusted as required based on the working conditions.

WARNING

Make sure the tractor's PTO is disengaged.
Turn off the engine, engage the parking brake, and remove the ignition key.

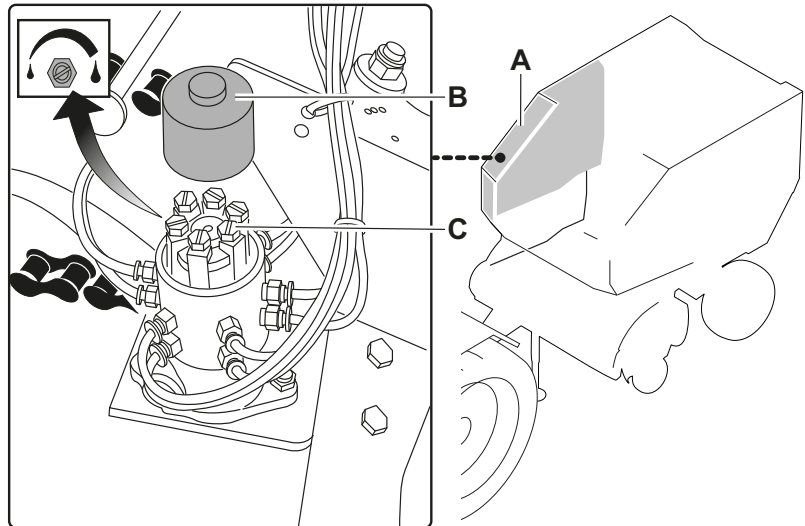

- ▶ Open the guard (A).
- ▶ Unscrew the cap (B).
- ▶ Check the quantity of oil (the pipes are color coded).
 - TIGHTEN the screws (C) to increase the quantity.
 - LOOSEN the screws (C) to decrease the quantity.
- ▶ Replace the cap (B).
- ▶ Close the guard (A).

The illustration shows the diagram for connecting the centralized lubrication system to the pump.

General maintenance of the machine

Models equipped with rotor

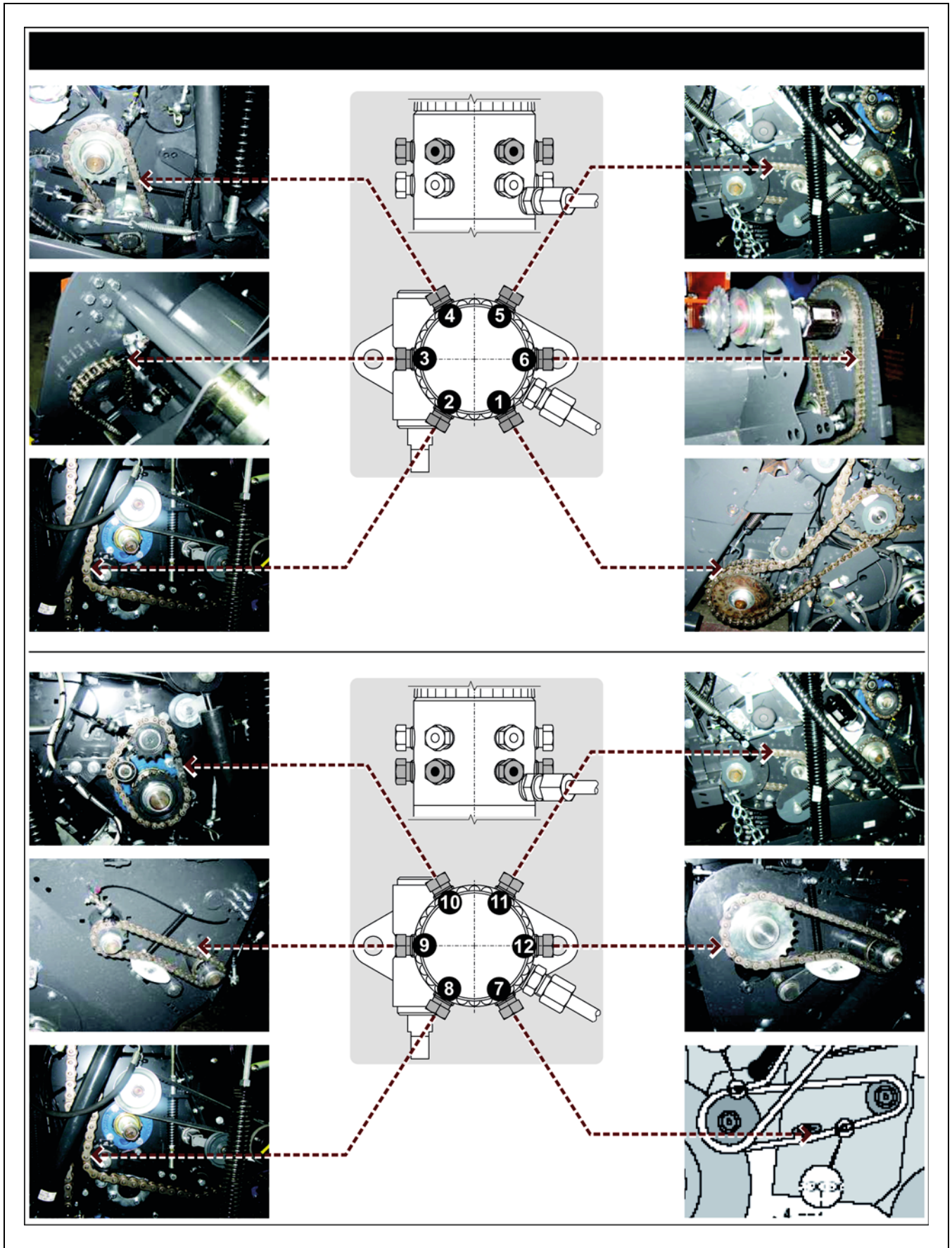

General maintenance of the machine

Topping up the centralized lubrication system's oil

WARNING

Make sure the tractor's PTO is disengaged.
Turn off the engine, engage the parking brake, and remove the ignition key.

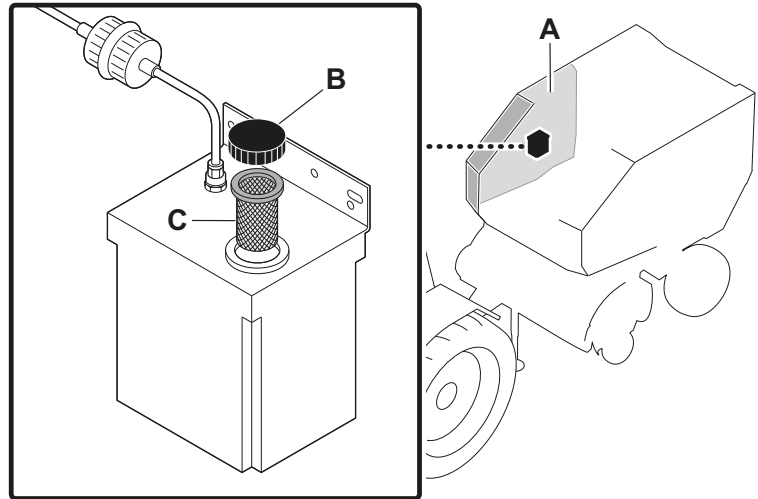

- ▶ Open the guard (A).
- ▶ Thoroughly clean the area so that no dust or residues can enter the tank.
- ▶ Unscrew the filler cap (B).
- ▶ Check the conditions of the filter (C) and clean it thoroughly if obstructed.
- ▶ Pour new oil into the tank.
- ▶ Tighten the filler cap (B).
- ▶ Close the guard (A).

NOTICE

Use oils with characteristics identical to those specified in the "Lubricant table".

Adjusting the cleaning rollers

WARNING

Make sure the tractor's PTO is disengaged.
Turn off the engine, engage the parking brake, and remove the ignition key.

Bladed roller for cleaning roller "M1"

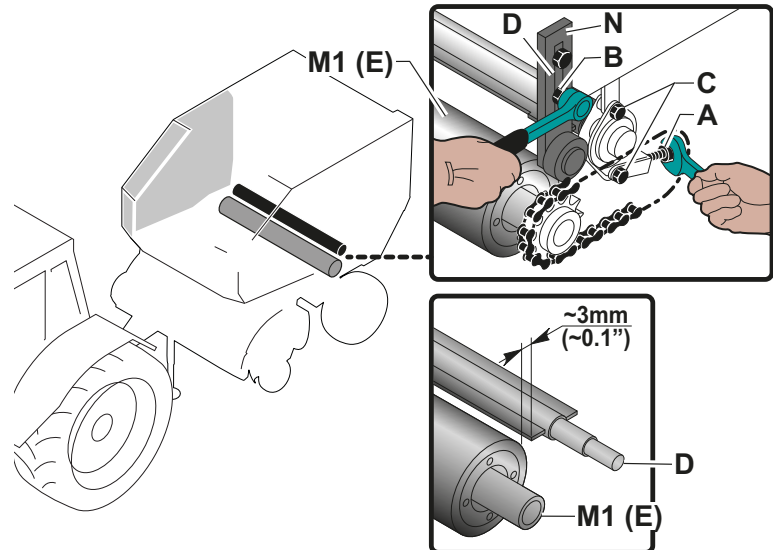

- ▶ Adjust the screws (B) to loosen the tensioner (N).
- ▶ On both sides, slightly loosen the nuts (C) that fasten the bearings.
- ▶ Adjust the screws (A) and the locknut to position the bladed roller (D).
Adjust the position of the bladed roller (D) at a distance of 3 mm (0.12") from roller "M1" (E).

NOTICE

During the adjustment, the bladed roller must be kept parallel to roller "M1".
In order to avoid damaging roller "M1", do not position the bladed roller at a distance less than that shown in the illustration.

- ▶ Tighten the nuts (C) on both sides.
- ▶ Adjust the screw (A) and the locknut to lock the bladed roller (D) in place.
- ▶ Manually adjust the tensioner (N) to regulate the tension of the chain and to tighten the screws (B) at the same time.

NOTICE

Do not tighten the transmission too much in order to avoid damaging the rotating devices.

General maintenance of the machine

Bladed roller for cleaning roller "R4"

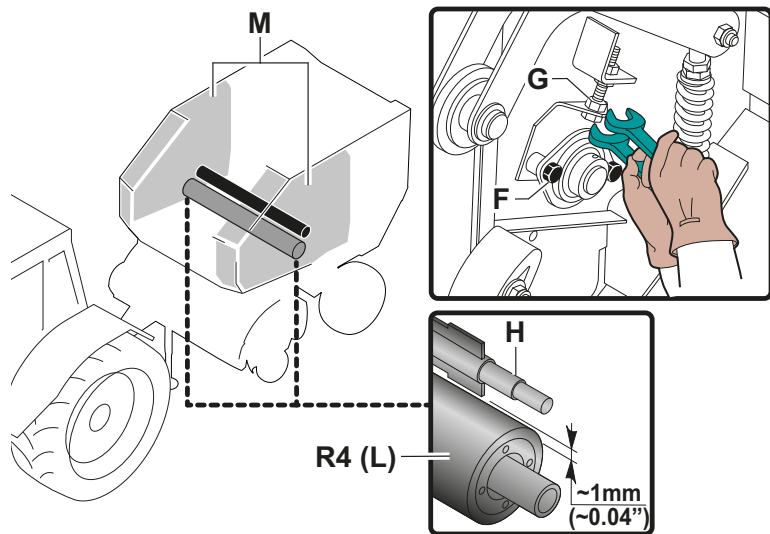

- ▶ Open the guards (M).
- ▶ On both sides, slightly loose the screws (F) that fasten the bearings.
- ▶ Equally adjust the screw (G) and the locknut on both sides to set the position of the bladed roller (H).

▶

NOTICE

During the adjustment, the bladed roller must be kept parallel to roller "R4" (L).
In order to avoid damaging roller "R4", be careful not to position the bladed roller at a distance less than that shown in the illustration.

- ▶ Tighten the screws (F-G) on both sides.
- ▶ Close the guards (M).

Checking the belts' alignment

WARNING

Make sure the tractor's PTO is disengaged.
Turn off the engine, engage the parking brake, and remove the ignition key.

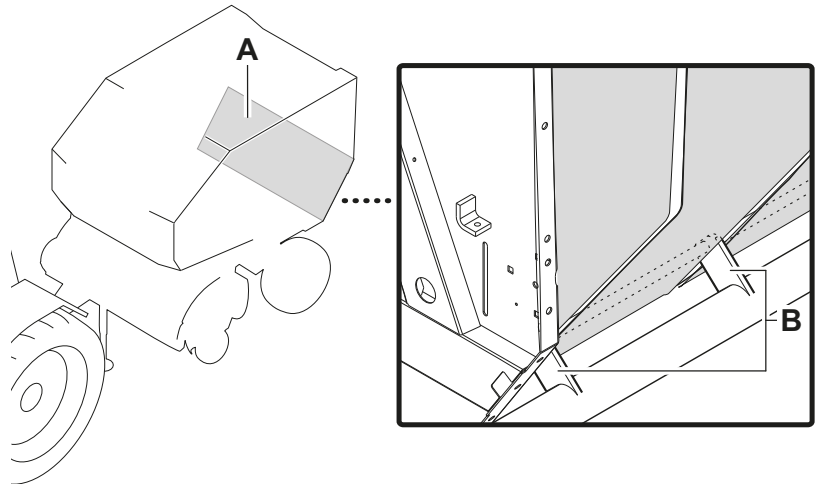

- ▶ Check that a formed bale is inside the machine.
- ▶ Unscrew the screws to remove the guard (A).
- ▶ Check whether the wear status of the separators (B) is uniform on both sides. If they are worn more on one side, the belts need to be aligned (See “Adjusting the belts' alignment”).
- ▶ Assemble the guard (A) and fasten it with the screws.

General maintenance of the machine

Adjusting the belts' alignment

WARNING

Make sure the tractor's PTO is disengaged.
Turn off the engine, engage the parking brake, and remove the ignition key.

- ▶ Check that a formed bale is NOT inside the machine.
- ▶ Make sure the tailgate is completely and correctly closed.
- ▶ Check the direction (right or left) in which the belts have moved. During bale formation, the belts could move laterally towards their respective dividers, thus resulting in excessive wear.

CAUTION

During the design and construction phases, no measure were adopted to allow the operator to access the upper areas of the machine.

If the machine's upper areas need to be accessed, take appropriate safety measures to avoid the relative risks, especially the risk of falling from heights.

Belts misaligned towards the right side

If the belts become misaligned towards the right side, do the following to realign them.

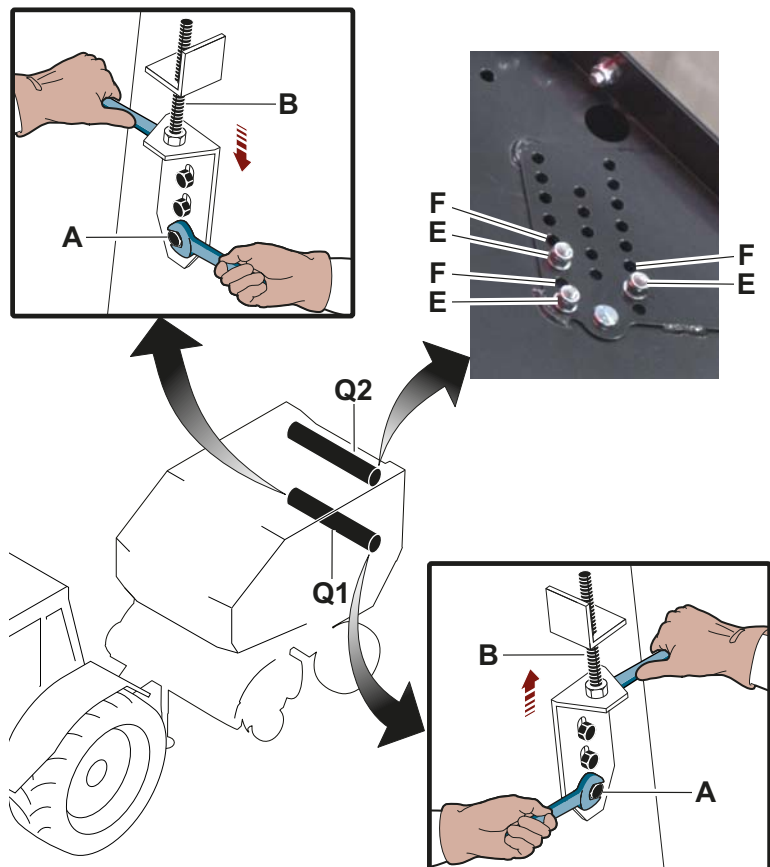

- ▶ On the right side of the machine, loosen the screws (A) and lower the roller (Q1) using the adjustment screw (B). As an alternative, you can perform a different operation.

General maintenance of the machine

On the left side of the machine, loosen the screws (A) and lift the roller (Q1) using the adjustment screw (B).

Tighten the screws (A) once the operation has been completed.

- If the adjustment does not appear sufficient, proceed in the indicated manner.
- Position yourself on the left-hand side.
- Remove the screws (E).
- Align the roller (Q2) with the holes (F), insert the screws, and tighten them lightly (E).
- The holes to be used are those just above the previous position.
- Tighten the screws (E).
- Check to make sure that the belt remains properly aligned.
- Repeat the adjustment operation using the screws (B) if the belt does not remain aligned.

Belts misaligned towards the left side

If the belts become misaligned towards the left side, do the following to realign them.

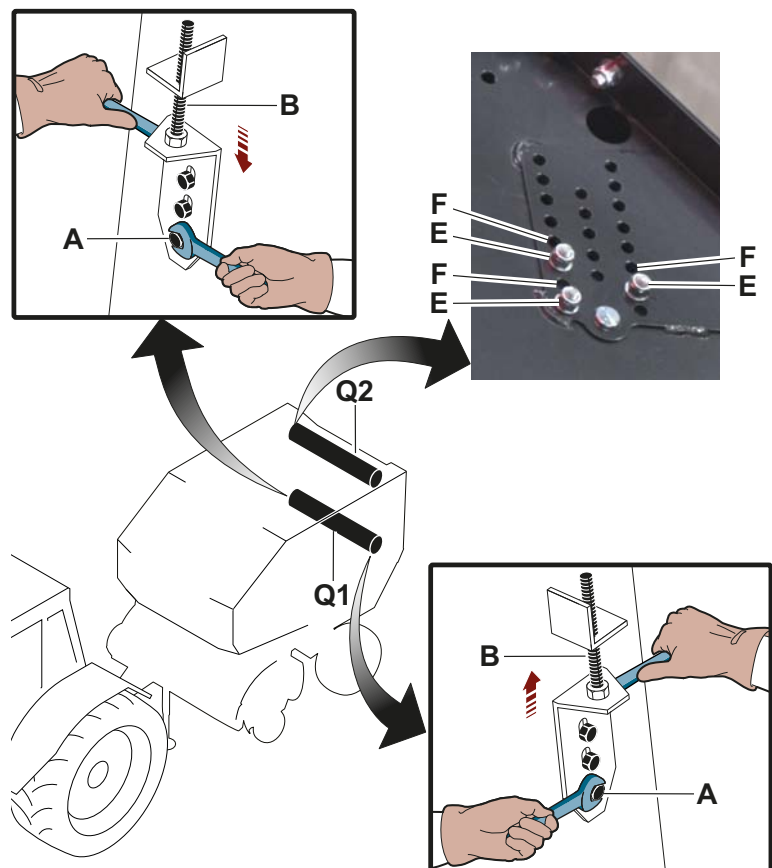

- On the right side of the machine, loosen the screws (A) and lift the roller (Q1) using the adjustment screw (B).

As an alternative, you can perform a different operation.

On the left side of the machine, loosen the screws (A) and lower the roller (Q1) using the adjustment screw (B).

Tighten the screws (A) once the operation has been completed.

- If the adjustment does not appear sufficient, proceed in the indicated manner.
- Position yourself on the right-hand side.
- Remove the screws (E).

General maintenance of the machine

- Align the roller (**Q2**) with the holes (**F**), insert the screws, and tighten them lightly (**E**).
- The holes to be used are those just above the previous position.
- Tighten the screws (**E**).
- Check to make sure that the belt remains properly aligned.
- Repeat the adjustment operation using the screws (**B**) if the belt does not remain aligned.
- ▶ Start the engine, activate the PTO and adjust it to its minimum speed.
- ▶ Check the alignment between the belts and repeat the adjustment if necessary.

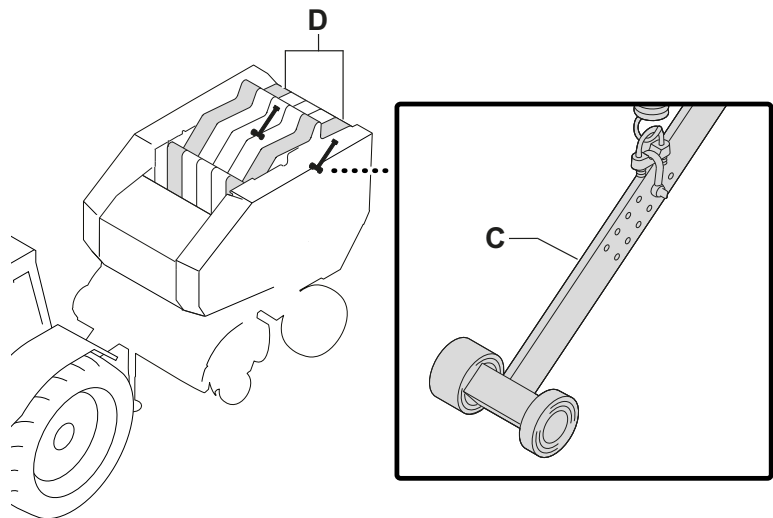

- ▶ If only the alignment of the side belts (**D**) needs to be corrected, “twist” the arms (**C**) of the tensioning elements in one direction or the other.

CAUTION

Do not modify the position of the tensioning springs. This adjustment may only be carried out by the manufacturer during the production phase.

General maintenance of the machine

Cleaning the belt guiding rollers

WARNING

Make sure the tractor's PTO is disengaged.
Stop the tractor with the engine running and engage the parking brake.

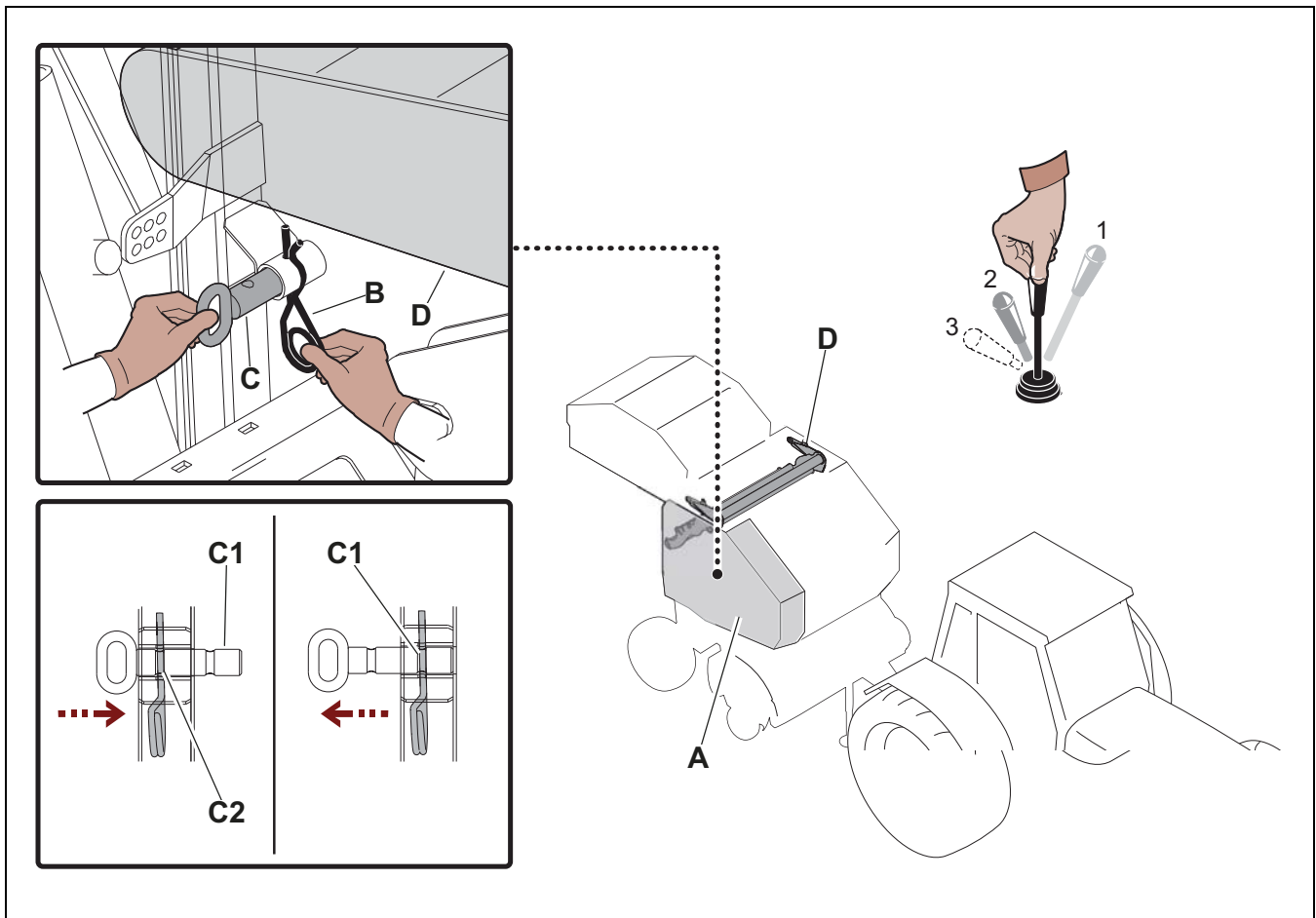

- ▶ Open the guard (A).
- ▶ Bring the tractor's hydraulic control valve lever to position 1 to open the tailgate fully.
- ▶ Remove the safety pin (B) from the hole (C1) in the pin (C), push the pin inward, and insert the safety pin (B) into the hole (C2).

NOTICE

In order to avoid breakage, the pin (C) can only be inserted after the tailgate has opened completely.
Make sure that the pin (C) is fully inserted in order to make sure that the tensioner unit rests on the pin.
If it is not possible to insert the pin (C) completely, contact the manufacturer's Technical Support Service or your local dealer.

- ▶ Bring the tractor's hydraulic control valve lever to position 2, and

General maintenance of the machine

release it once the tensioning unit (D) is resting on the component (C). This will cause the belts to loosen.

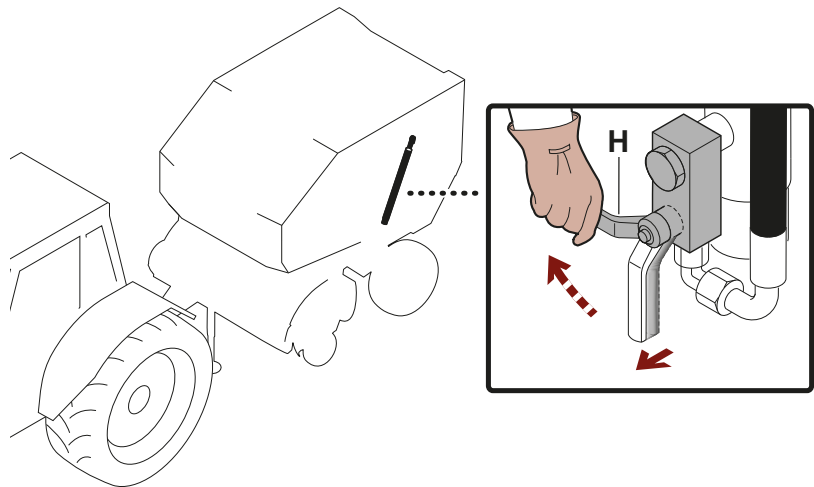

- ▶ Close the safety valve (H) to ensure safe working conditions.
- ▶ Shut off the engine and remove the ignition key.
- ▶ Clean and eliminate any product residues between the rollers and the belts.
- ▶ Check the general conditions of the parts inside the baling chamber.
- ▶ Open the safety valve (H).



NOTICE

Make sure that the cleaning operation has been completed before opening the safety valve.

- ▶ Start the tractor's engine from the driver's seat.
- ▶ Bring the tractor's hydraulic control valve lever to position 1 to open the tailgate.
- ▶ Remove the safety pin (B) and extract the pin (C), then reinsert the safety pin into the hole (C1).
- ▶ Bring the tractor's hydraulic control valve lever to position 2 to close the tailgate.
- ▶ Close the guard (A).

Replacing the baling chamber's belts

WARNING

Make sure the tractor's PTO is disengaged.
Stop the tractor with the engine running and engage the parking brake.

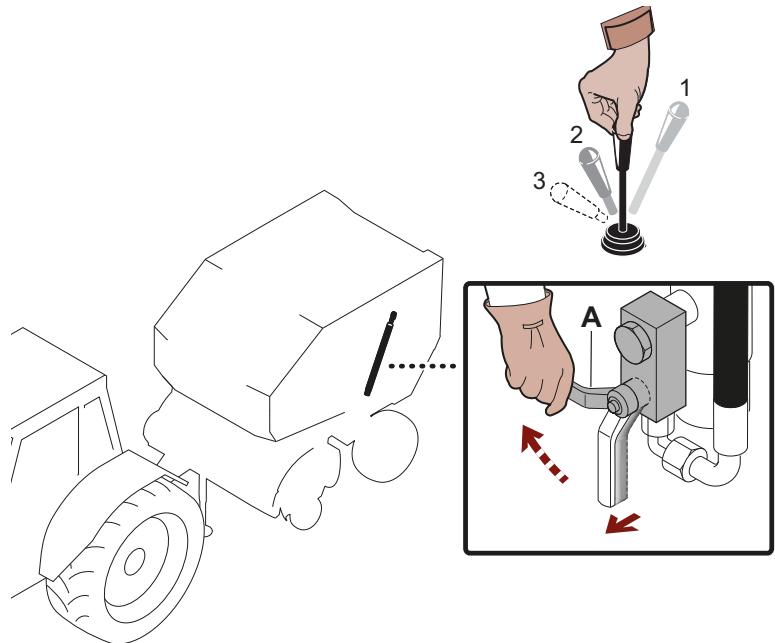

- ▶ Bring the tractor's hydraulic control valve lever to position 1 to open the tailgate fully.
- ▶ Close the safety valve (A) to ensure safe working conditions.
- ▶ Loosen the belts (See "Cleaning the belt guiding rollers").
- ▶ Shut off the engine and remove the ignition key.

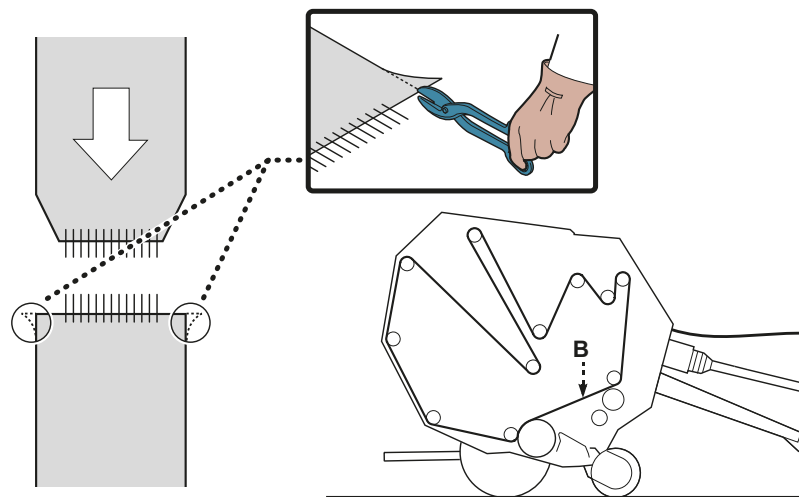

- ▶ Remove the pin from the belt joint (B).
- ▶ Remove the belt (B).

General maintenance of the machine

NOTICE

If more than one belt is removed, mark references so that you will be able to reinstall the belts in their original positions and operating directions.

- ▶ Install the new or repaired belt (**B**). Install the belt on the drive rollers and pay attention to the direction of the belt's bevel in relation to the forward direction of the belt itself (see the figure). When installing the belt, pay attention to the round copper plated bar on the side of the belt in contact with the bale.

NOTICE

If the joint needs to be restored, trim the edges of the belt with a cutter on the end without bevels in order to avoid any unwanted widening due to the assembly of the joint itself. It is recommended to assemble the new belts in a central position.

The length difference between the belts installed on the machine must never exceed 30 mm (1.18").

- ▶ On the beveled part of the belt, cut the external hook closest to the edge of the belt. In this manner, the side hooks on the beveled part of the belt will remain inside the hooks on the non-beveled part.

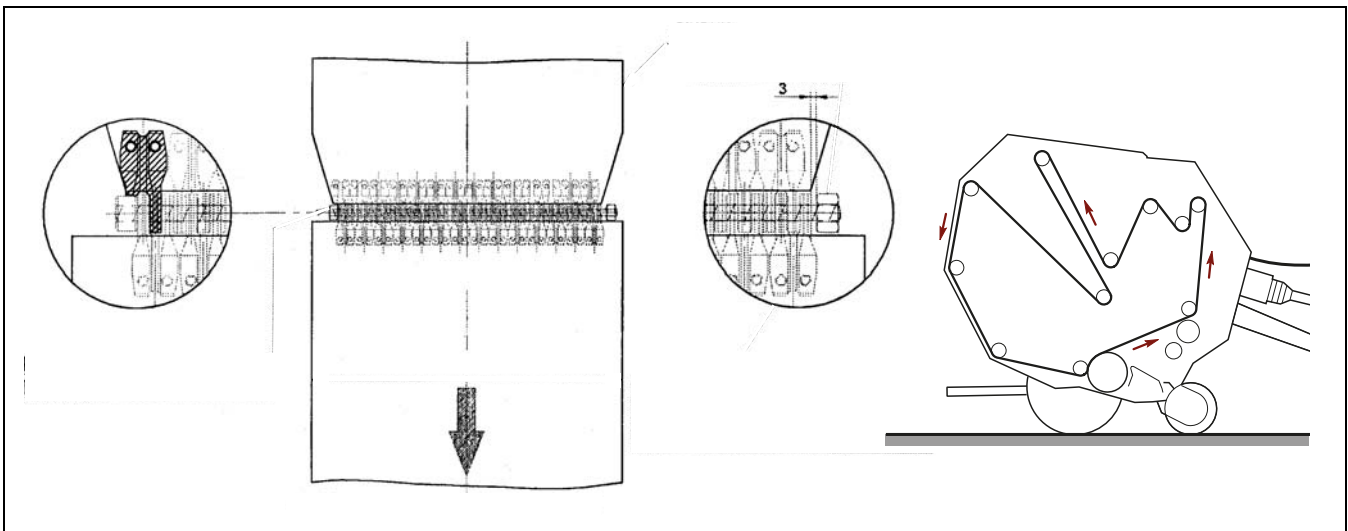

- ▶ Assemble the pin with the welded hook, as shown in the figure.
- ▶ Start the tractor's engine from the driver's seat.
- ▶ Open the safety valve (**A**).
- ▶ Bring the tractor's hydraulic control valve lever to position **2** to close the tailgate.

General maintenance of the machine

Manual equipment for vise (“MATO” type junctions)

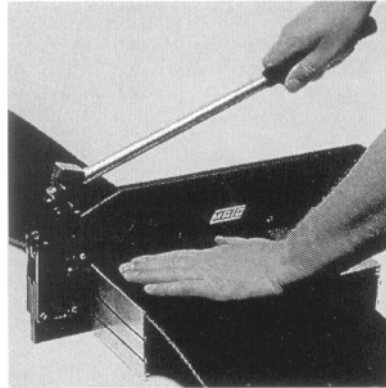

- ▶ Square the end of the belt.

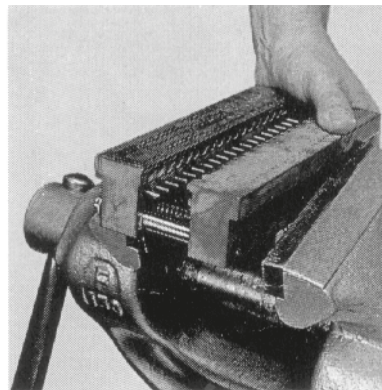

- ▶ Position and tighten the equipment “Profi 19”, which is completely open, in a bench vise with the holes turned forward.

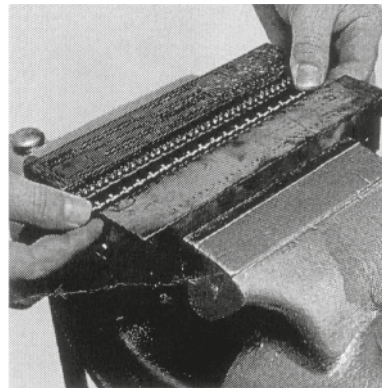

- ▶ Insert the joints into the holes in the equipment. Start the operation from the holes on the left.

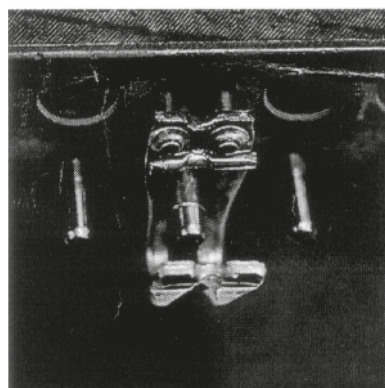

- ▶ Insert two pins at a time into a single hole.

General maintenance of the machine

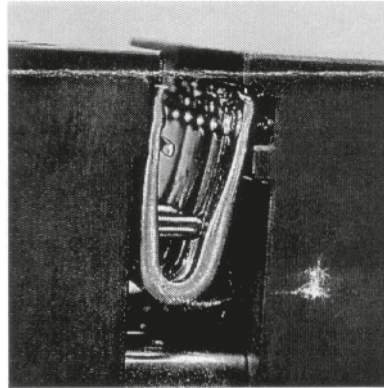

- ▶ Before inserting the belt, tighten the vise until the joints are slightly tightened and the belt can be easily inserted.

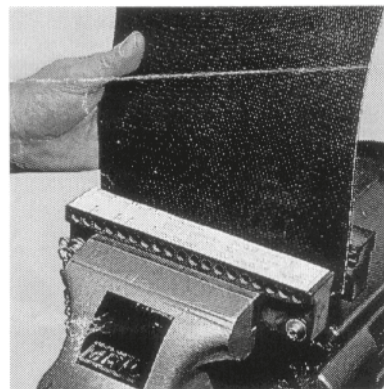

- ▶ Introduce the first end of the belt. Position the edge of the belt close to the mark (width of the belt or number of couplings).

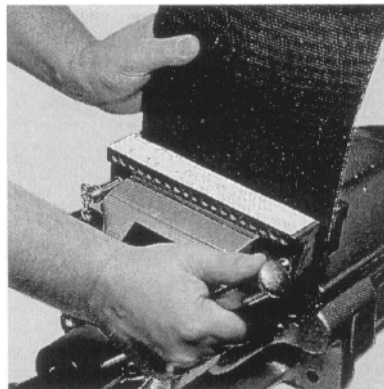

- ▶ Press the belt downwards in a uniform way up to the stop pins, and then tighten the vise until the joints are slightly tight.

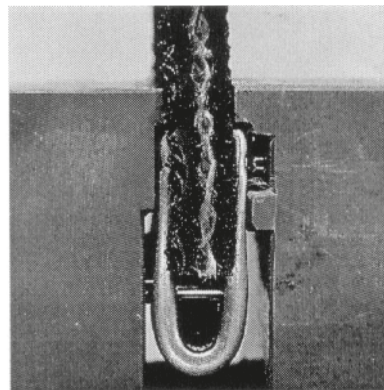

General maintenance of the machine

- ▶ The belt must rest on the stop pins. Close the joint until it touches the surface of the belt.

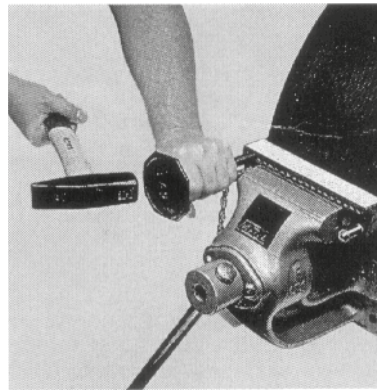

- ▶ Using a hammer, insert the punch into the left hole until it touches the equipment. Strike the punch another 3 times to create the head of the nail.

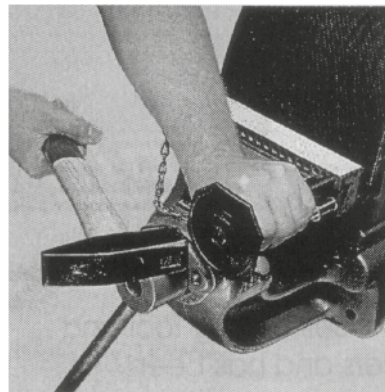

- ▶ Using a hammer, insert all the nails into the belt (proceed from right to left).

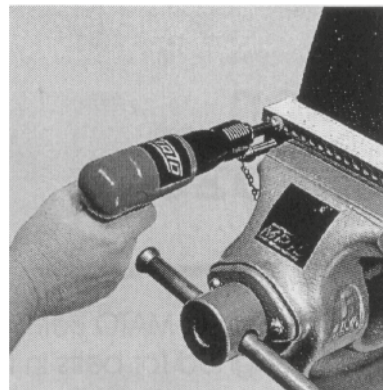

This procedure can be simplified by using a pneumatic drill with a special body.

General maintenance of the machine

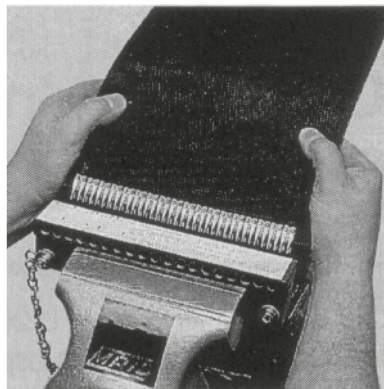

- ▶ Open the vise and press the belt slightly backwards to remove it.

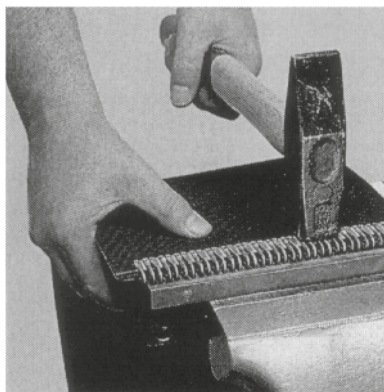

- ▶ Crush the nail on a solid base.



NOTICE

Pay attention not to hit or damage the circular part of the coupling.

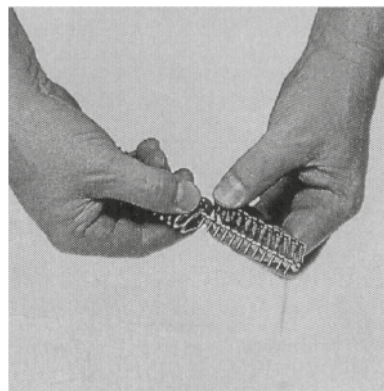

- ▶ For belts with different widths, twist and remove the excessive hooks.

General maintenance of the machine

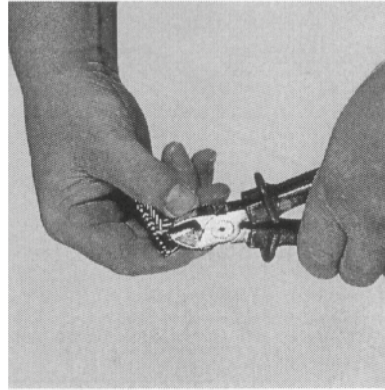

- ▶ Cut off the protruding weld bead.

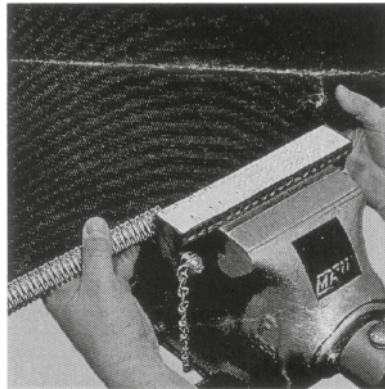

The same connection method can be applied to belts of any width.

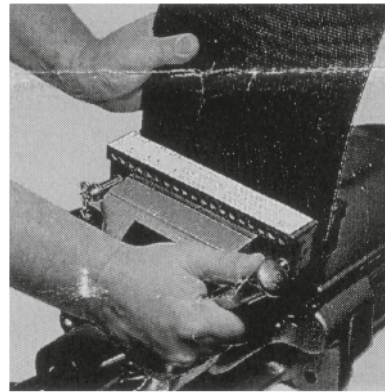

- ▶ Repeat the entire procedure for the other end of the belt. The same side of the belt must be turned forward.

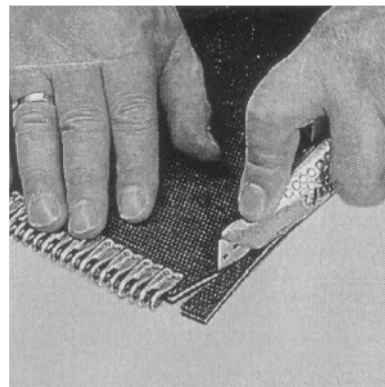

- ▶ Only bevel the corners of one end of the belt. Leave 1 mm (0.04") of the belt adjacent to the coupling, and cut ~25mm (0.98").

General maintenance of the machine

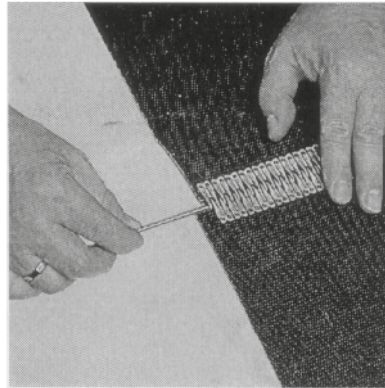

- ▶ In order to join the ends of the belt, connect the joints together and make sure that the ends of the belt are aligned, then insert the joint pin.

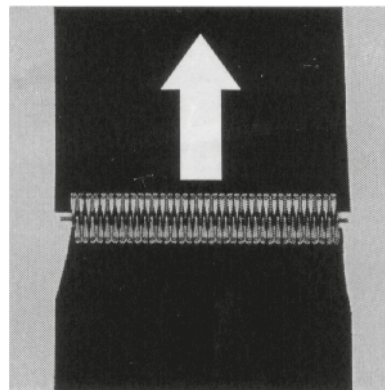

The beveled end must move forward in the direction of the pulling.

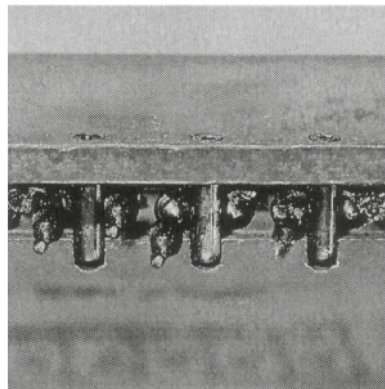

- ▶ For a perfect assembly, use a small metal brush to remove the rubber particles that have been trapped by the tool.

Replacing the tires

WARNING

Position the machine on a stable and level surface.
Turn off the engine, engage the parking brake, and remove the ignition key.

WARNING

The tire replacement operation can pose certain risks, above all considering the overall weight of the machine.
In order to avoid these risks (even potentially serious ones), it is recommended to have the operation carried out by expert personnel (at a tire repair shop, for example) who are capable of performing the intervention a safe and proper manner.
If it is not possible to have the job performed by an expert, it is essential to take all the necessary safety precautions to prevent any sudden and uncontrolled movements of the machine or its components.

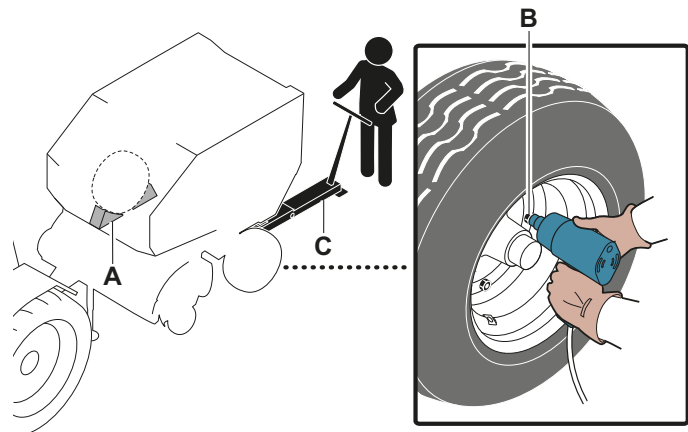

- ▶ Place the safety chocks (A) on the opposite side to the tire to be replaced, as shown in the figure.
- ▶ Slightly loosen the nuts (B).



- ▶ Insert the lifting device (C) into the point indicated on the special plate installed close to the tire to be replaced.
- ▶ Lift the machine in order to remove the wheel.
- ▶ Fully unscrew the nuts (B), and remove the wheel.
- ▶ Replace the tire.

General maintenance of the machine

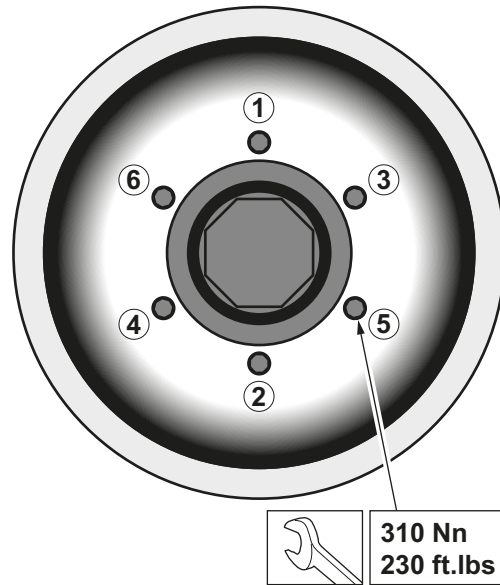

- ▶ Reapply the wheel and tighten the nuts in the sequence indicated in the figure.
Tighten the nuts with a tightening torque of 310 Nm (230 lbs*ft)
- ▶ Lower the machine, and fully tighten the nuts (**B**).
- ▶ Inflate the tire to the pressure indicated on the chart (See "Technical data").
- ▶ Remove the lifting device (**C**) once the operation has been completed.
- ▶ Remove the safety wedges (**A**).
- ▶ Check nut tightening after 2-3 working hours.

General maintenance of the machine

WARNING

If the standard tires are to be replaced with other of a different size, make sure that the hub's position is consistent with the new wheel size to be mounted.

Otherwise adjust the position of the hub based on the size of the new wheel (see the table).

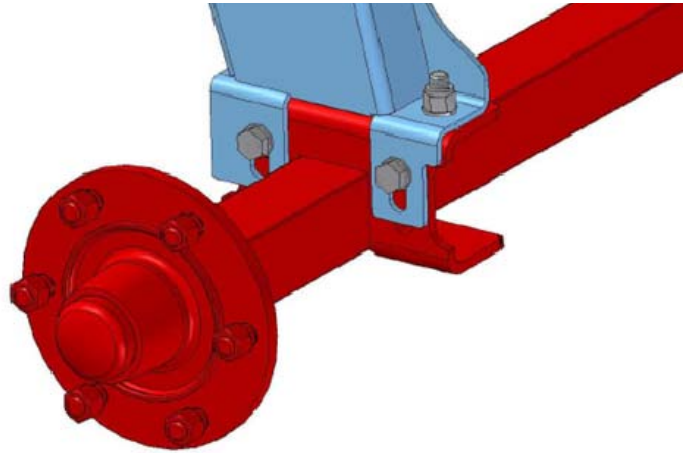

Position 1

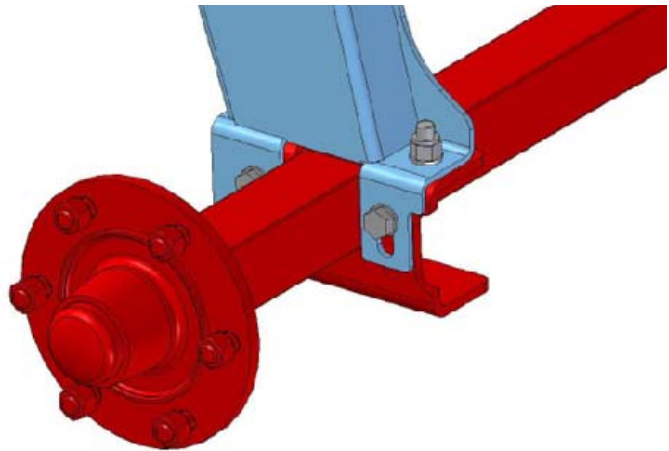

Position 2

Position 1	Position 2
11.5/80-15"	550/45-22.5"
15.0/45-17"	
19.0/45-17"	
500/50-17"	

General maintenance of the machine

Page intentionally left blank

Pick-up unit (extra-wide type)

General description

The pick-up unit picks up the product in the windrow and conveys it to the machine's feeding area.

The functions of the unit's parts are activated by the main drive of the machine upon which it is installed.

The unit is equipped with a clutch that automatically disengages in order to avoid damaging the machine in the event of a blockage.



NOTICE

After having restored the unit's normal operating conditions, the clutch automatically engages.

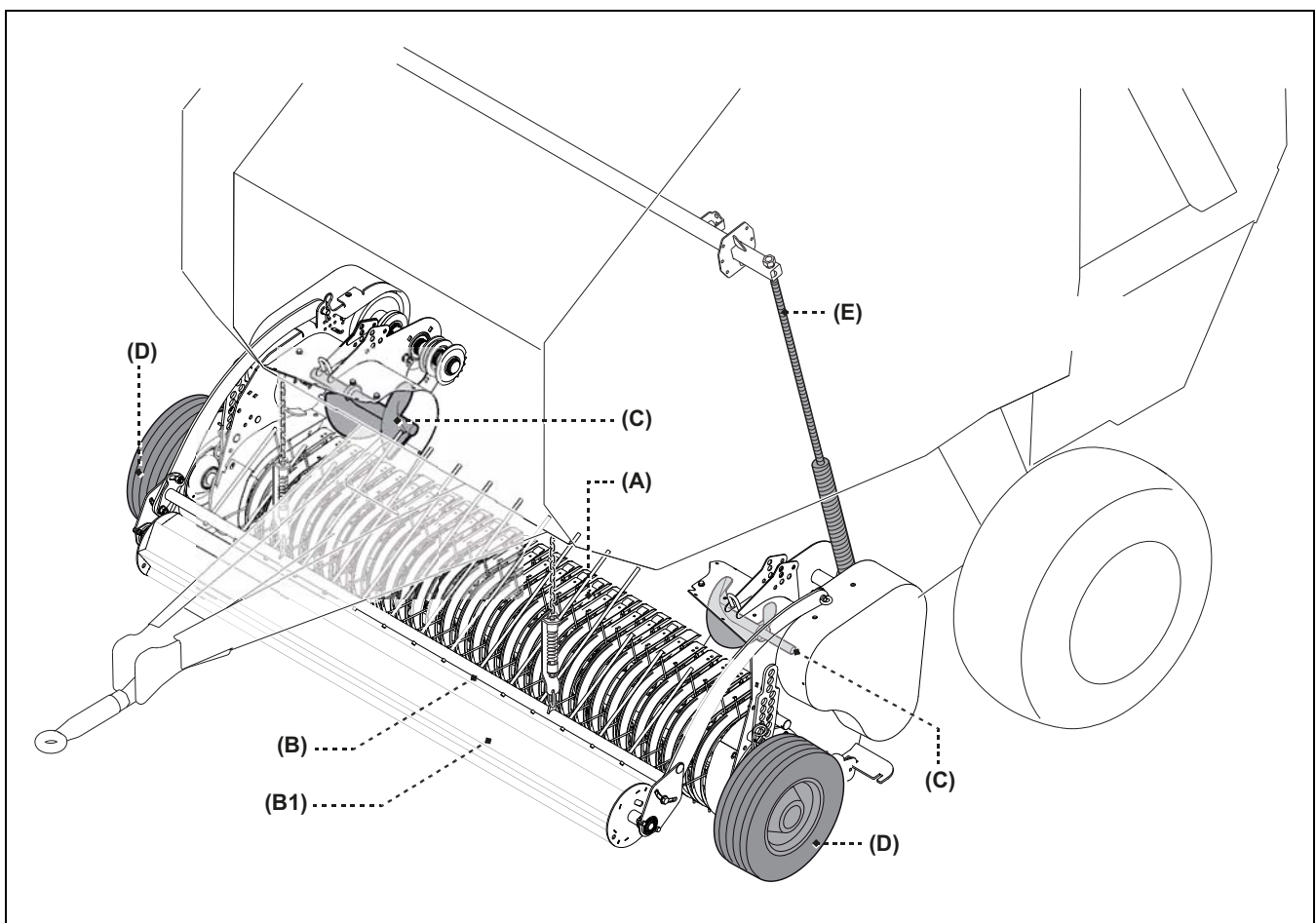

- A) **“Reel” device:** is equipped with two cams that guide the tine-holder bars.
- B) **Baffle plate:** allows for a more regular feeding of the product, even in the case of short and chopped products.
On machines equipped with a rotor or chopping device, a roller (**B1**) is also installed, which further improves the feeding of the product.
- C) **Auger:** there are two of them (one on each side); they convey the product and adapt it to the width of the baling chamber.
- D) **Wheel:** there are two of them (one on each side) and, with a suspension system (**E**), they allow the pick-up unit to adapt to the var-

Pick-up unit (extra-wide type)

ious ground profiles and protect the tines and cams of the pick-up unit from any damages.

Hydraulic devices

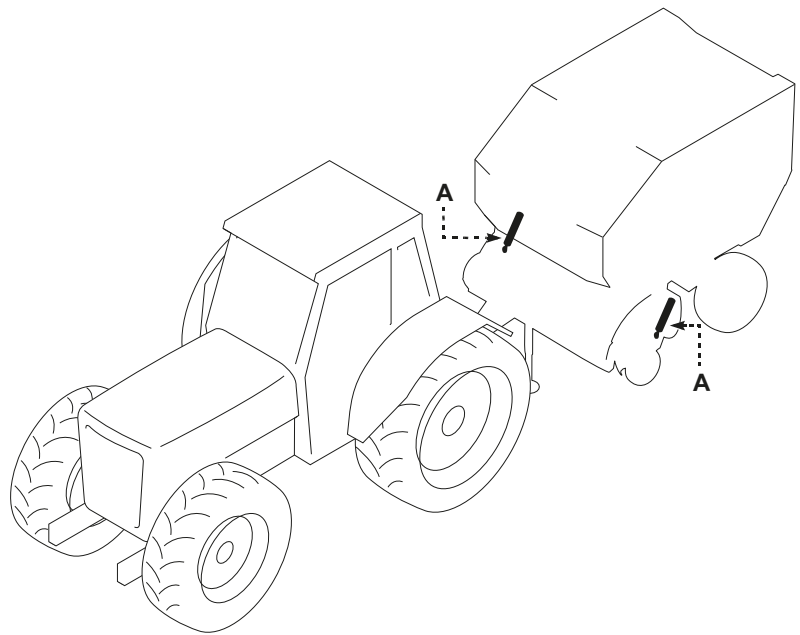

A) **Hydraulic cylinder:** lifts and lowers the pick-up unit.

Handling the pick-up unit

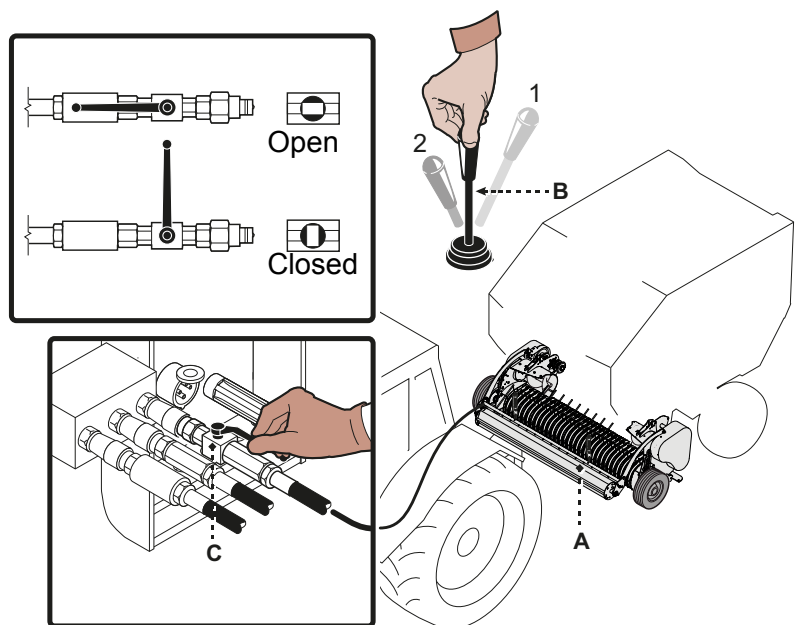

- ▶ During normal operating conditions, keep the valve (C) open in order to be able to raise and lower the pick-up unit.
- ▶ Bring the tractor's hydraulic control valve lever (B) to position 1 to raise the pick-up unit(A), or position 2 to lower it.

Pick-up unit (extra-wide type)

CAUTION

If the machine needs to be moved on a public highway, close the valve (C) to keep the pick-up unit safely raised. Secure the pick-up unit in place using the special chain (if present).

Unblocking the pick-up unit

The unblocking tool (B) is only present on certain machine models. A similar tool can be purchased separately if necessary.

WARNING

Make sure the tractor's PTO is disengaged. Turn off the engine, engage the parking brake, and remove the ignition key.

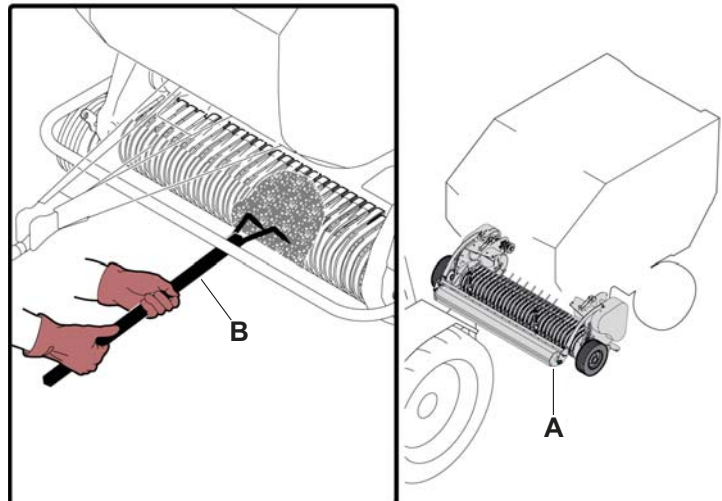

- ▶ Wear appropriate personal protective equipment (glasses, gloves, etc.) to protect your eyes and upper limbs.
- ▶ Remove the product that's blocking the pick-up unit (A) using the special tool (B).

CAUTION

Hold the tool by the end in order to keep a safe distance from the unblocking zone and to avoid the risk of contact with dangerous parts.

- ▶ If necessary, dismantle the baffle plate to facilitate the product's removal.
- ▶ Restart the engine and engage the PTO to check whether the pick-up unit has been cleared.
If not, open the tailgate to facilitate the product removal operation.

Pick-up unit (extra-wide type)

Adjusting the pick-up unit's suspension

- The pick-up unit's suspension must be adjusted based on the machine's forward speed and the type of terrain.
- Proper adjustment will allow the pick-up unit to remain resting on the ground with its wheels, and to rise correctly whenever it encounters an obstacle.

NOTICE

The pick-up unit must be balanced in such way as to create a downward force of approximately 30-40 kg (60-90 lbs) upon the terrain.

WARNING

Make sure the tractor's PTO is disengaged. Turn off the engine, engage the parking brake, and remove the ignition key.

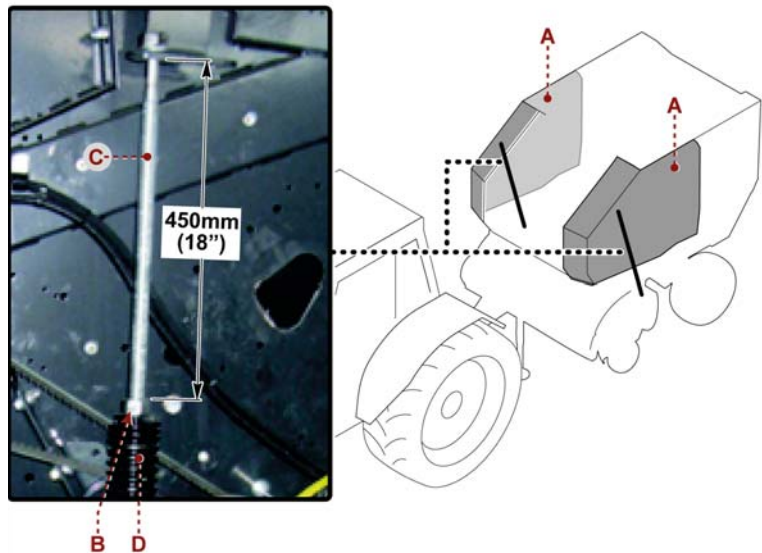

To balance the pick-up unit, follow the instructions.

- ▶ Open the guard (A).
- ▶ Adjust the compression of the spring (D) using the lock nut (B) and the tensioning element (C).
 - ▶ Tighten the tensioning element (C) to reduce the load on the spring (D).
 - ▶ Loosen the tensioning element (C) to increase the load on the spring (D).
- ▶ Tighten the lock nut (B) once the operation has been completed.
- ▶ Close the guard (A).

NOTICE

The distance shown in the picture is approximate. Its value may vary based on the position and the working conditions of the pick-up unit.

Pick-up unit (extra-wide type)

Adjusting the height of the pick-up unit

The height of the pick-up unit must be adjusted on the basis of the product to be collected and the conformation of the windrow.

CAUTION

During the collection operations, the tines of the pick-up unit must not come into contact with the terrain.

WARNING

Make sure the tractor's PTO is disengaged.

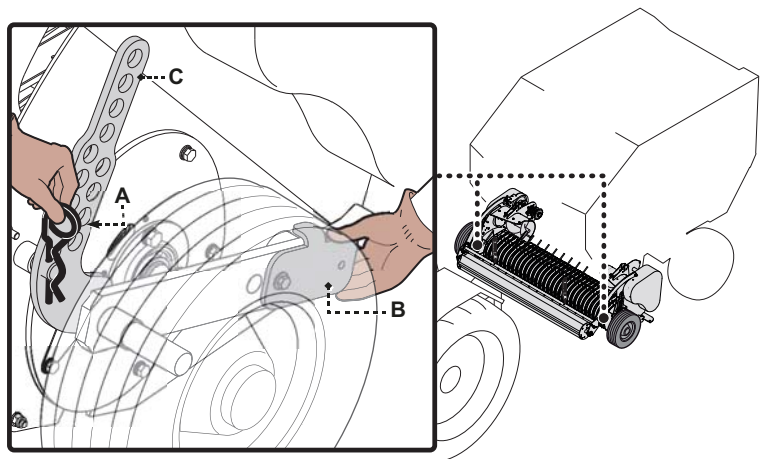

To do the adjustment, follow the instructions.

- ▶ Raise the pick-up unit so that its wheels are off the ground.
- ▶ Turn off the engine, engage the parking brake, and remove the ignition key.
- ▶ Remove the split pin (A).
- ▶ Lift the safety plate (B).
- ▶ Slightly extract the wheel-holder arm (C), and then rotate it to obtain the desired height.
- ▶ Re-insert the arm into the new hole.
- ▶ Re-insert the locking plate (B).
- ▶ Insert the split pin (A).
- ▶ Repeat the operation on the other side, making sure to use the same hole.

Pick-up unit (extra-wide type)

Adjusting the tilting baffle plate

WARNING

Make sure the tractor's PTO is disengaged.
Turn off the engine, engage the parking brake, and remove the ignition key.

Adjusting the height of the baffle plate

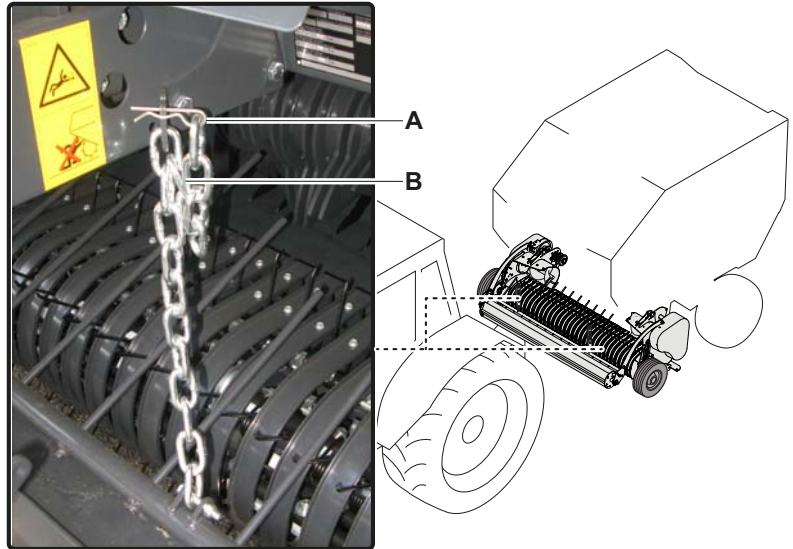

- ▶ Remove the split pin (A).
- ▶ Release the chain (B), and then reconnect it in such a way as to position the baffle plate at the desired height.
- ▶ Insert the split pin (A).
- ▶ Repeat the operation on the other side and make sure to use the same holes.

Adjusting the tilt of the baffle plate

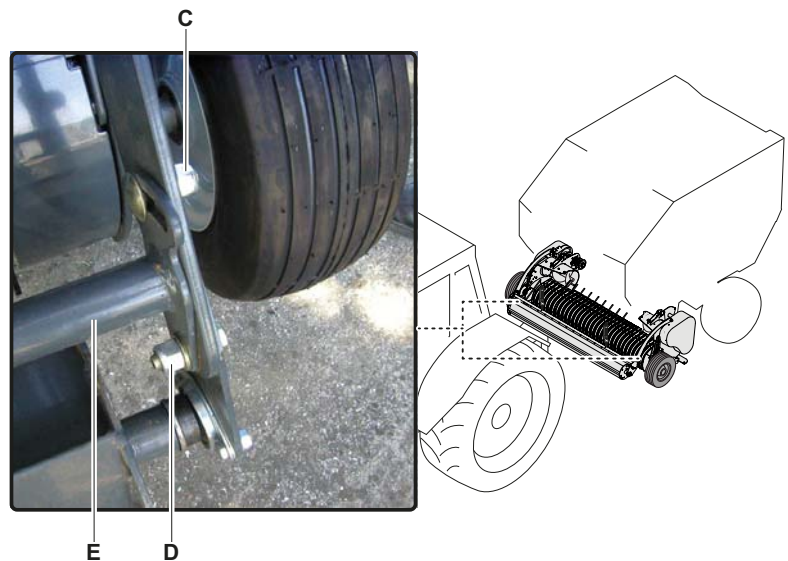

- ▶ Loosen the nuts (C-D) on both sides.
- ▶ Set the tilt of the baffle plate (E) and lightly tighten the nuts (C).
- ▶ Tighten the nuts (C-D).

Pick-up unit (extra-wide type)

Adjusting the feed roller's position

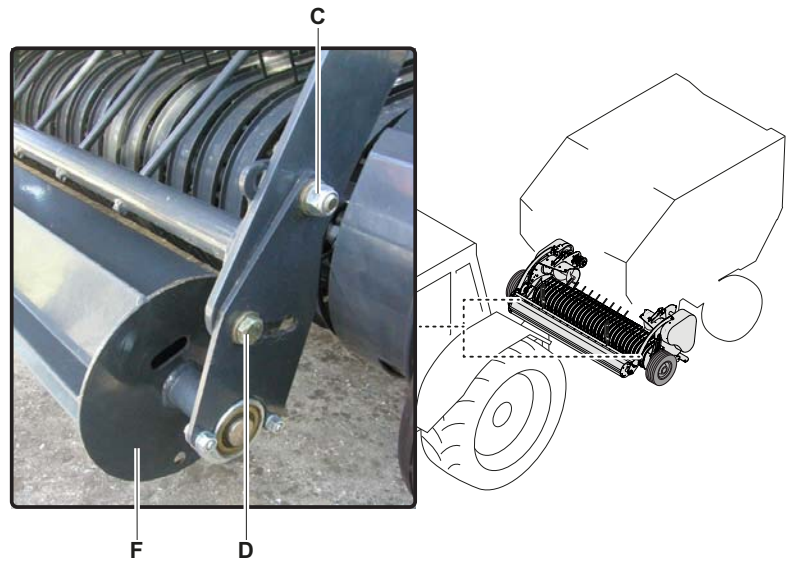

- ▶ Loosen the nuts (C-D) on both sides.
- ▶ Adjust the position of the roller (F), and then slightly tighten the nuts (D).
- ▶ Tighten the nuts (C-D).

Adjusting the pick-up unit's transmission chain

WARNING

Make sure the tractor's PTO is disengaged. Turn off the engine, engage the parking brake, and remove the ignition key.

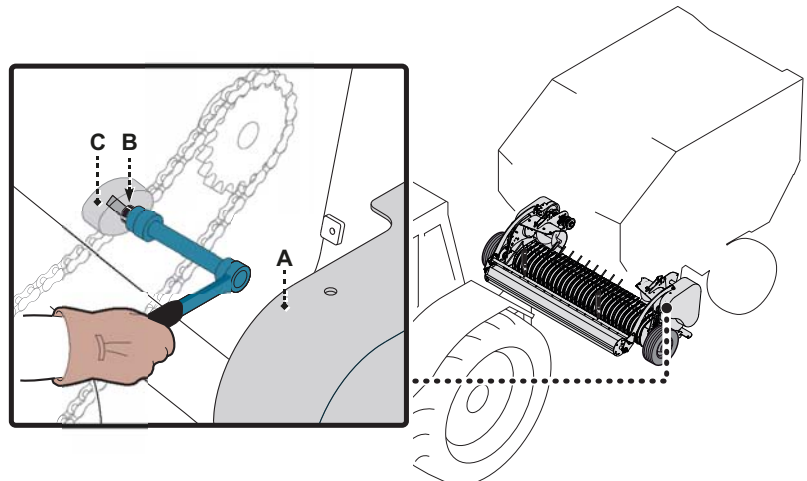

Follow the instructions.

- ▶ Unscrew the screws to remove the guard (A).
- ▶ Loosen the nut (B), move the tensioning unit (C) to adjust the tensioning of the chain and tighten the nut (B).
- ▶ Assemble the guard (A) and fasten it with the screws.

CAUTION

Check the chain every 50 working hours and adjust it if necessary in order to prevent it from coming off the pinion.

Pick-up unit (extra-wide type)

Page intentionally left blank

Feeding unit (rotor)

General description

The "ROTOR" feeding unit conveys the product to the baling chamber. The functions of the unit's parts are activated by the main drive of the machine upon which it is installed.

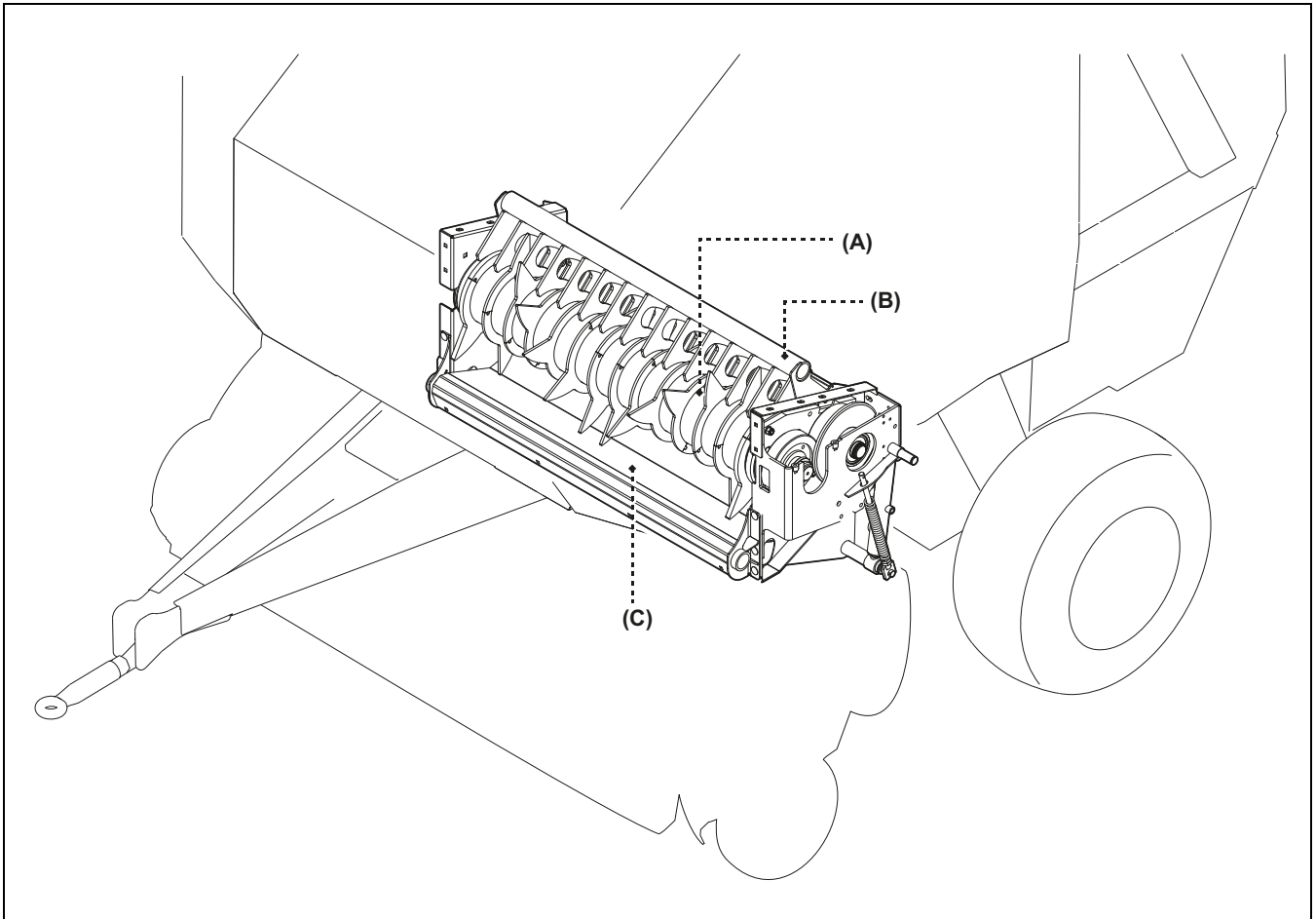

- A) **Feeder device:** receives the product from the pick-up unit and conveys it to the baling chamber.
- B) **Scraper:** prevents the product from backing up and wrapping around the feeding device.
- C) **"Drop floor" device:** it unblocks the feeding unit in case of blockage.

Feeding unit (rotor)

Electrical devices

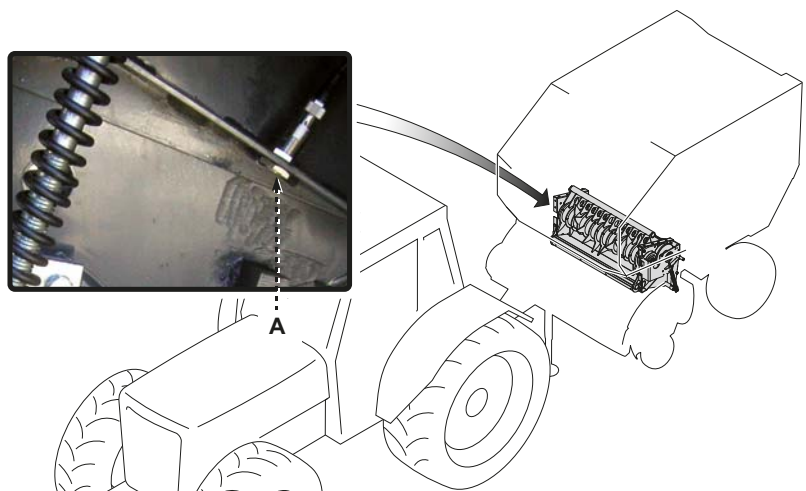

- A) **Sensor:** it detects the table of the "Drop floor" device in "raised" position.

Hydraulic devices

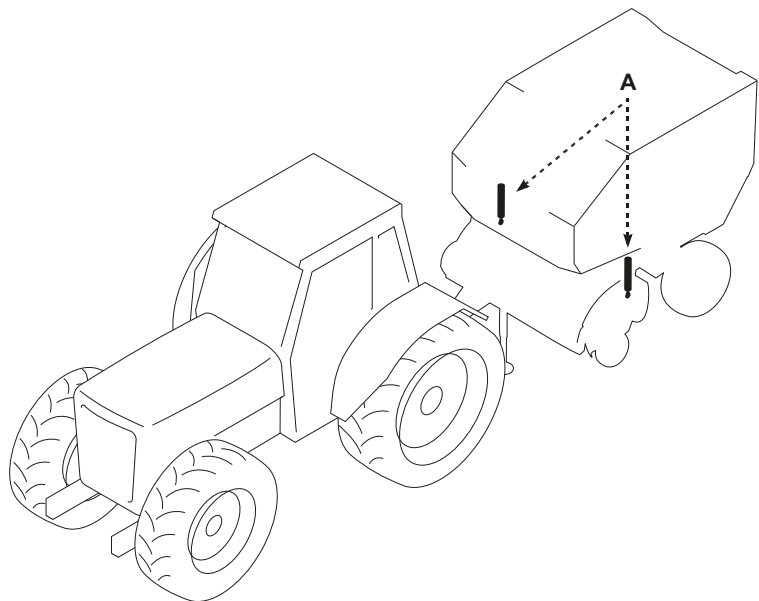

- A) **Hydraulic circuit:** it raises and lowers the table of the "Drop floor" device.

Unblocking the feeding unit

WARNING

Make sure the tractor's PTO is disengaged.
Stop the tractor with the engine running and engage the parking brake.

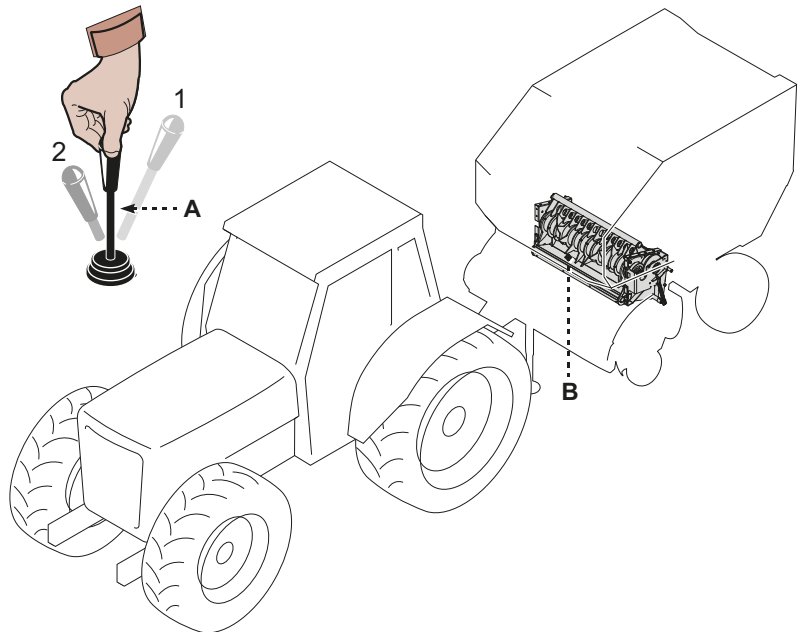

Follow the instructions.

- ▶ Act on the commands of the electronic control system to activate the controls of the "Drop floor" device.
- ▶ Move the lever (A) of the tractor's hydraulic control valve (from position 1 to position 2) to lower the bed of the "Drop floor" device (B) and unblock the feeding unit.
- ▶ Use the lever (A) to bring the table of the "Drop floor" device back to the "raised" position.
The electronic control system gives a signal when the position is reached..
- ▶ Act on the commands of the electronic control system to deactivate the controls of the "Drop floor" device.
- ▶ Activate the PTO to check whether the feeding unit has been cleared.

Feeding unit (rotor)

Page intentionally left blank

Feeding unit (Supercut)

General description

The "SUPERCUT" feeding unit (14 knives) cuts the product uniformly before conveying it to the baling chamber. The functions of the unit's parts are activated by the main drive of the machine upon which it is installed.

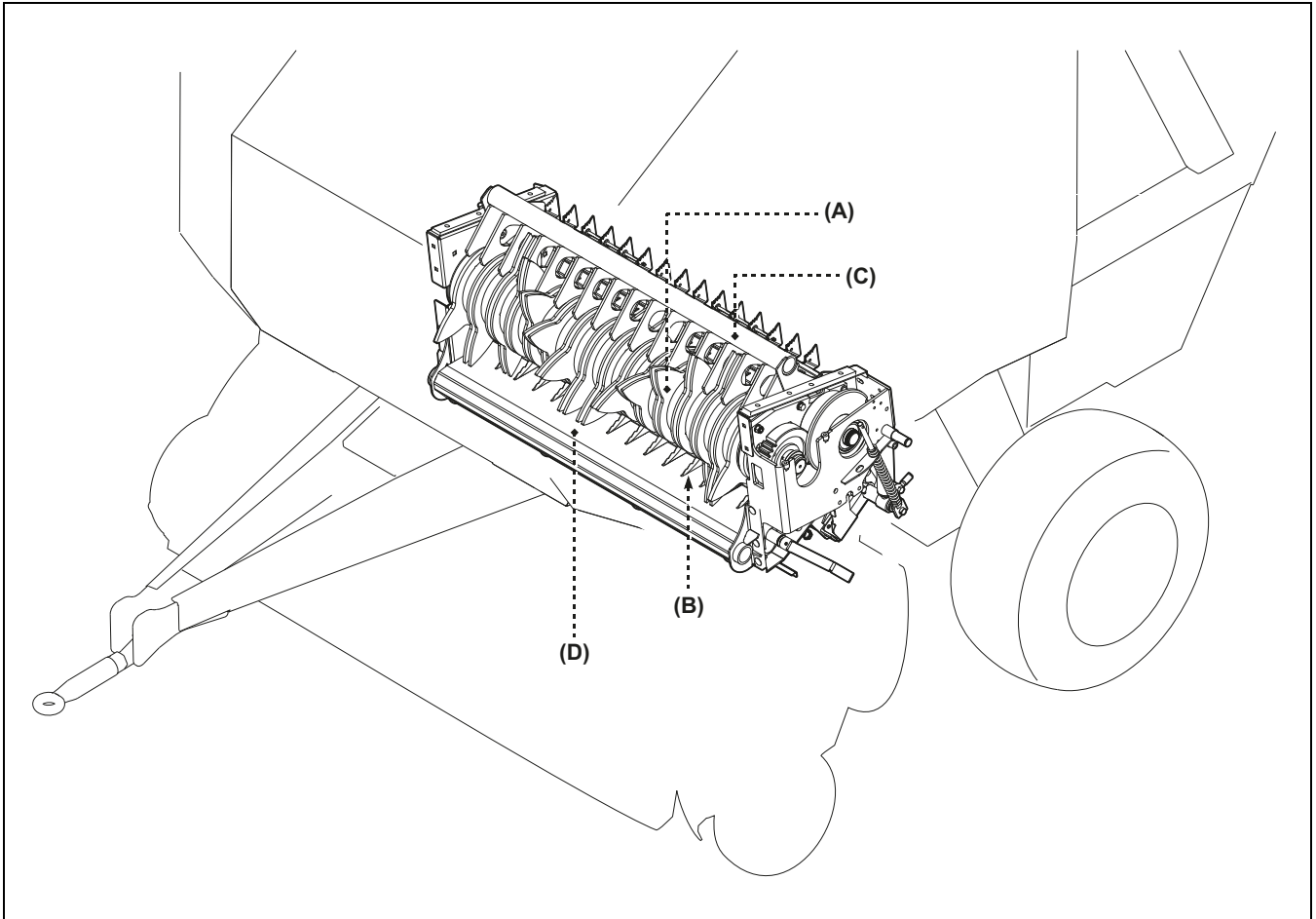

- A) **Feeder device:** receives the product from the pick-up unit, chops it and conveys it to the baling chamber.
- B) **Knives:** they cut the product, together with the scraper. When a foreign object goes through, all knives involved go down to prevent plugging of the feeding unit; then they go back automatically to the operating position.
- C) **Scraper:** prevents the product from backing up and wrapping around the feeding device.
- C) **"Drop floor" device:** it unblocks the feeding unit in case of blockage.

Feeding unit (Supercut)

Electrical devices

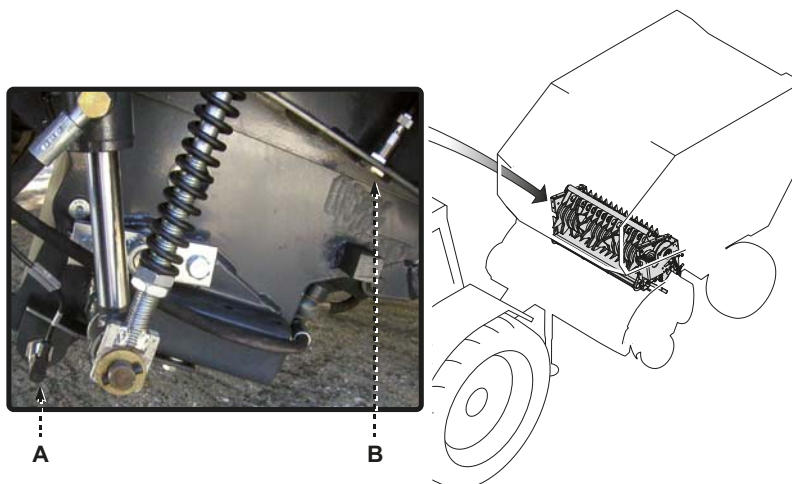

- A) **Sensor:** it detects the knives in the "raised" position.
- B) **Sensor:** it detects the table of the "Drop floor" device in "raised" position.

Hydraulic devices

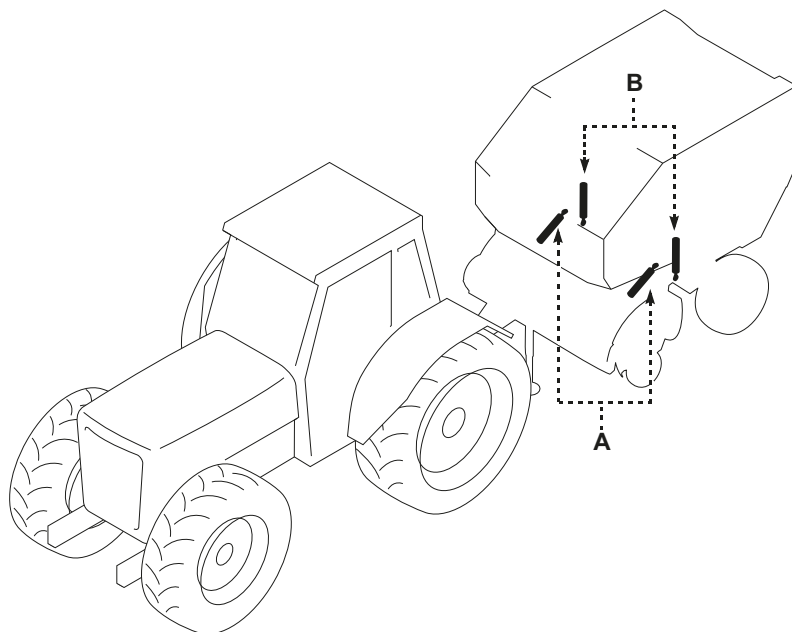

- A) **Hydraulic circuit:** it operates the knives of the chopping device.
- B) **Hydraulic circuit:** it raises and lowers the table of the "Drop floor" device.

Unblocking the feeding unit

WARNING

Stop the tractor without shutting off the engine, engage the parking brake, and disconnect the power take-off.

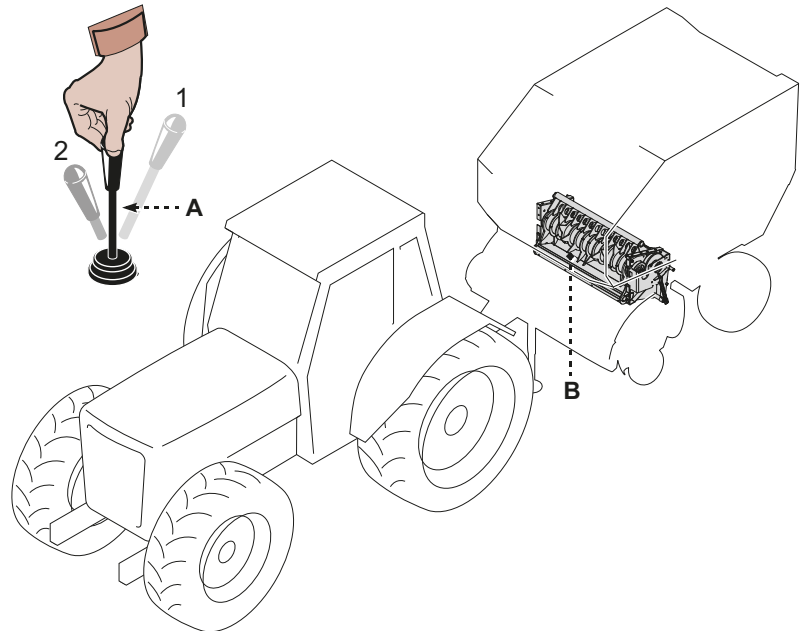

Follow the instructions.

- ▶ Act on the commands of the electronic control system to activate the controls of the "Drop floor" device.
- ▶ Move the lever (A) of the tractor's hydraulic control valve (from position 1 to position 2) to lower the table of the "Drop floor" device (B) and unblock the feeding unit.
- ▶ Use the lever (A) to bring the table of the "Drop floor" device back to the "raised" position.
The electronic control system gives a signal when the position is reached..
- ▶ Act on the commands of the electronic control system to deactivate the controls of the "Drop floor" device.
- ▶ Activate the PTO to check whether the feeding unit has been cleared.

Feeding unit (Supercut)

Knives' replacement

WARNING

Stop the tractor without shutting off the engine, engage the parking brake, and disconnect the power take-off.

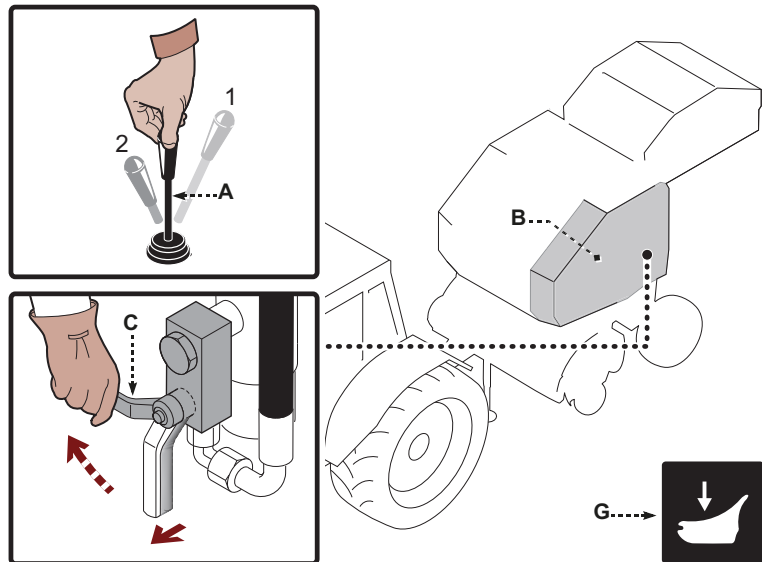

Follow the instructions.

- ▶ Act on the commands (G) of the electronic control system to lower the knives completely.
- ▶ Bring the lever (A) on the tractor's hydraulic control valve to position 1 to open the tailgate.
- ▶ Shut off the engine and remove the ignition key.
- ▶ Open the guard (B).
- ▶ Close the safety valve (C) to ensure safe working conditions.

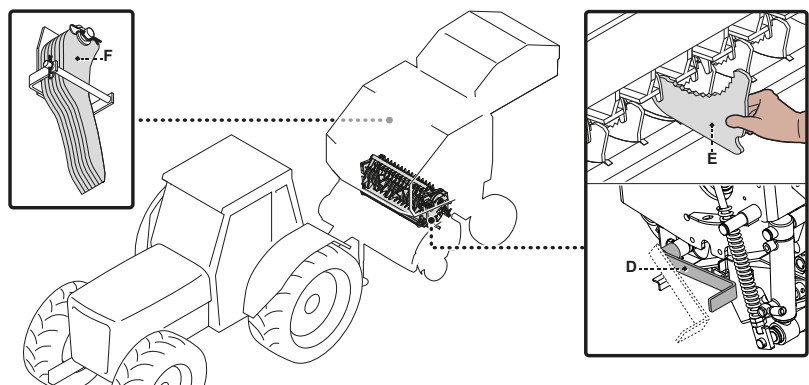

- ▶ Lower the lever (D) to unblock the knives.

CAUTION

Wear protective gloves in order to avoid the risk of cutting your hands.

- ▶ Slide out the knives (E) and replace them.

Feeding unit (Supercut)

- ▶ Lift the lever (D) to block the knives.
 - ▶ Open the safety valve(C).
 - ▶ Close the guard(B)
 - ▶ Restart the tractor's engine.
 - ▶ Bring the tractor's hydraulic control valve lever (A) to position 2 to close the tailgate.
 - ▶ Act on the commands of the electronic control system to lift the knives.
- The procedure described can be adopted also to decrease the number of knives (lightly chopped product) or to eliminate them completely (non-chopped product).
 - Assemble the replacement plates (F) at the points at which all or part of the knives (E) were removed, to prevent plugging and/or accumulations in the feeding slots.
 - The replacement plates are in a kit supplied on request; it is to be located on the right hand side.

Sharpening of knives

WARNING

Stop the tractor without shutting off the engine, engage the parking brake, and disconnect the power take-off.

- The product must be cut cleanly to ensure that it is fed correctly..
- If the product is not being fed correctly, check the conditions of the knives to assess whether they need sharpening.
- The conditions of the knives depend on the operating conditions and on the type of product being cut.
- In any case, the knives must be sharpened every 500 bales formed.

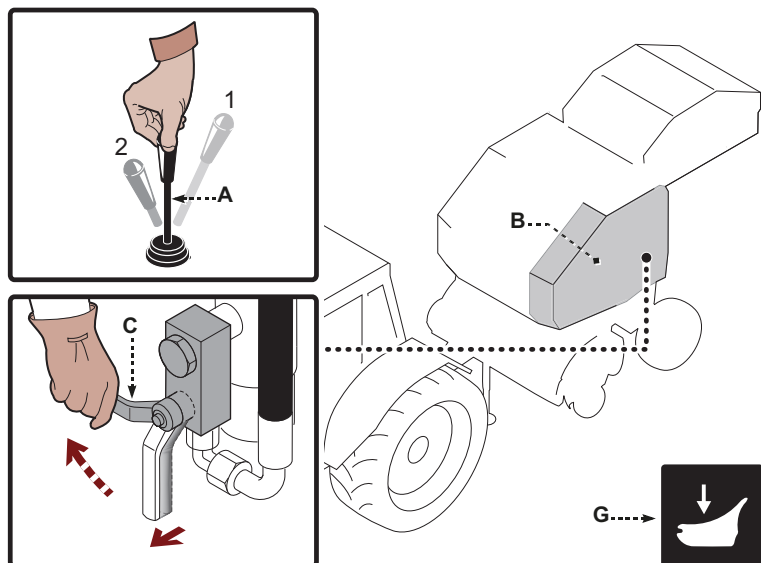

Follow the instructions.

- ▶ Act on the commands (G) of the electronic control system to lower

Feeding unit (Supercut)

the knives completely.

- ▶ Bring the lever (A) on the tractor's hydraulic control valve to position 1 to open the tailgate.
- ▶ Shut off the engine and remove the ignition key.
- ▶ Open the guard (B).
- ▶ Close the safety valve(C) to ensure safe working conditions.

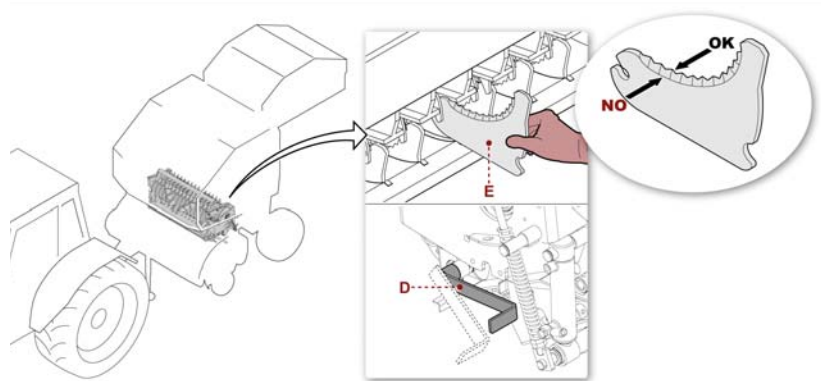

- ▶ Lower the lever (D) to unblock the knives.

CAUTION

Wear protective gloves in order to avoid the risk of cutting your hands.

- ▶ Slide out the knives (E).
- ▶ Sharpen the knives.

NOTICE

They must be sharpened only on the smooth side as indicated in the figure.

- To sharpen the knives, use a grinder and avoid overheating, to prevent irreparable damage to the temper of the knives.
- ▶ Reassemble the knives.
- ▶ Lift the lever (D) to block the knives.
- ▶ Open the safety valve(C).
- ▶ Close the guard(B).
- ▶ Restart the tractor's engine.
- ▶ Bring the tractor's hydraulic control valve lever (A) to position 2 to close the tailgate.
- ▶ Act on the commands of the electronic control system to lift the knives.

Feeding unit (powercut)

General description

The "POWERCUT" feeding unit (25 knives) cuts the product uniformly before conveying it to the baling chamber. The functions of the unit's parts are activated by the main drive of the machine upon which it is installed.

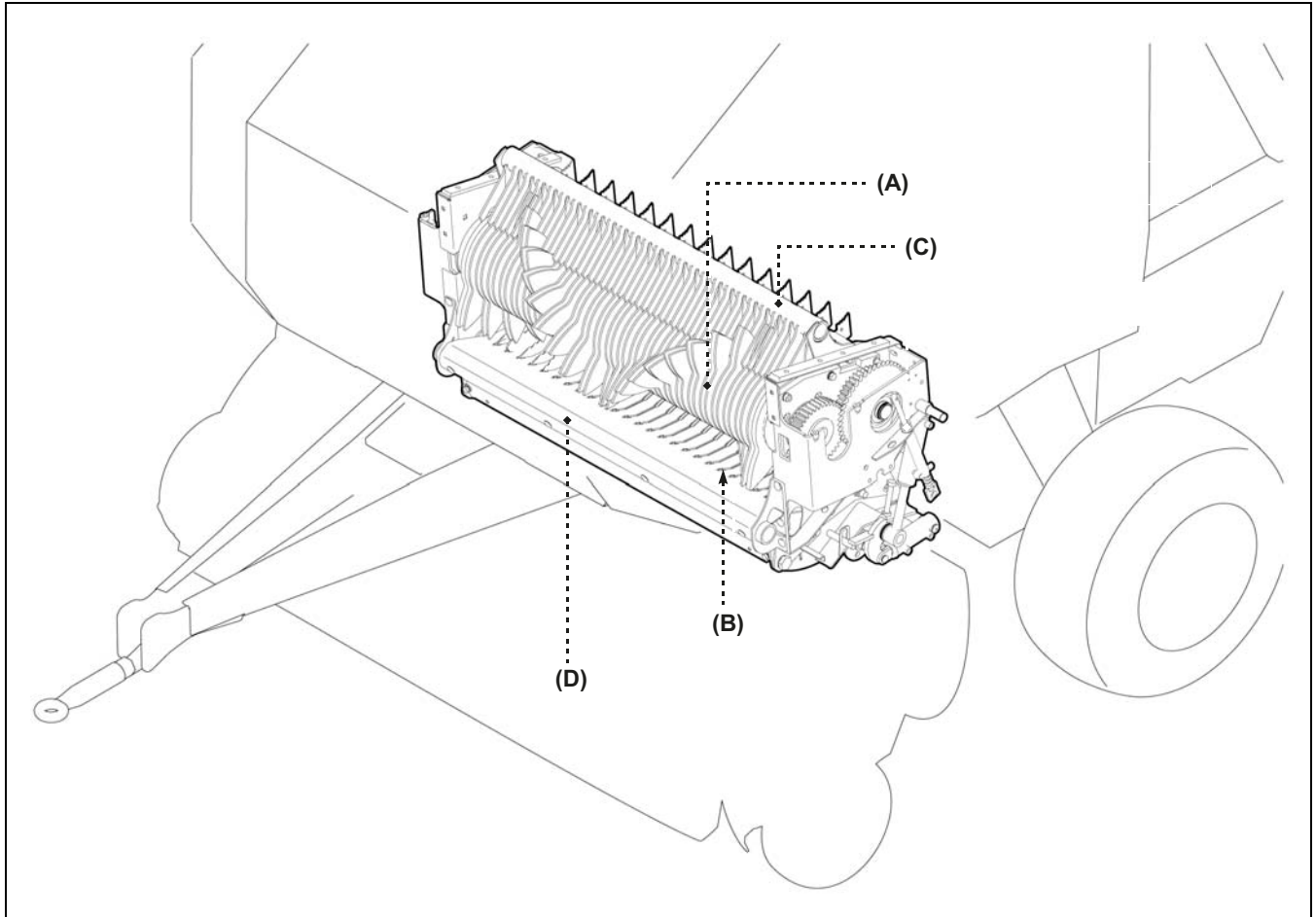

- A) **Feeder device:** receives the product from the pick-up unit, chops it and conveys it to the baling chamber.
- B) **Knives:** they cut the product, together with the scraper. When a foreign object goes through, all knives involved go down to prevent plugging of the feeding unit; then they go back automatically to the operating position.
- C) **Scraper:** prevents the product from backing up and wrapping around the feeding device.
- C) **"Drop floor" device:** it unblocks the feeding unit in case of blockage.

Feeding unit (powercut)

Electrical devices

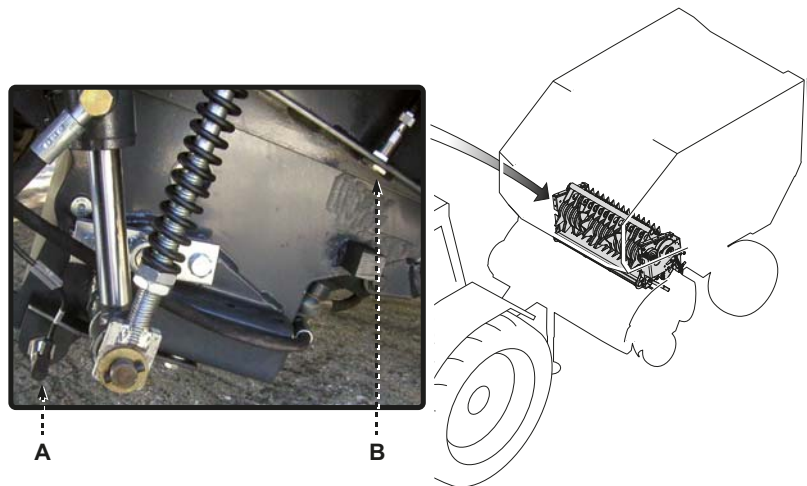

- A) **Sensor:** it detects the knives in the "raised" position.
- B) **Sensor:** it detects the table of the "Drop floor" device in "raised" position.

Hydraulic devices

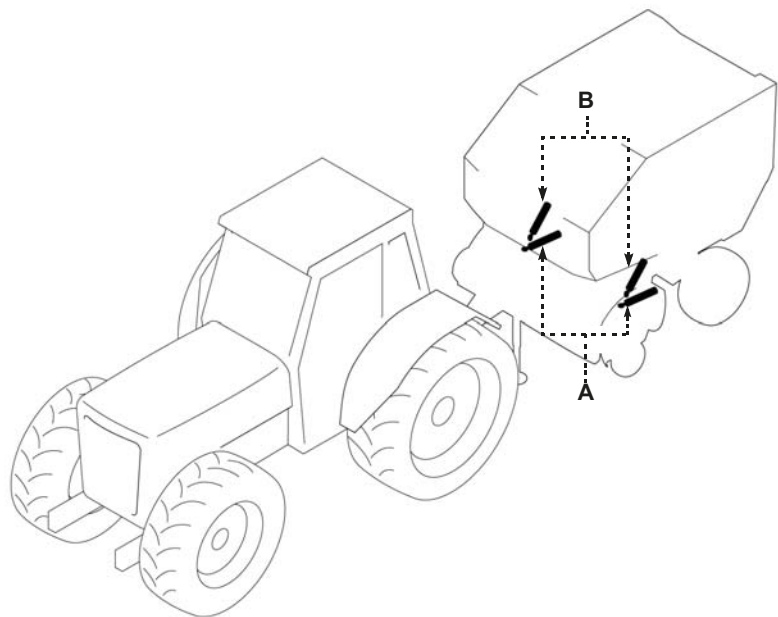

- A) **Hydraulic circuit:** it operates the knives of the chopping device.
- B) **Hydraulic circuit:** it raises and lowers the table of the "Drop floor" device.

Unblocking the feeding unit

WARNING

Stop the tractor without shutting off the engine, engage the parking brake, and disconnect the power take-off.

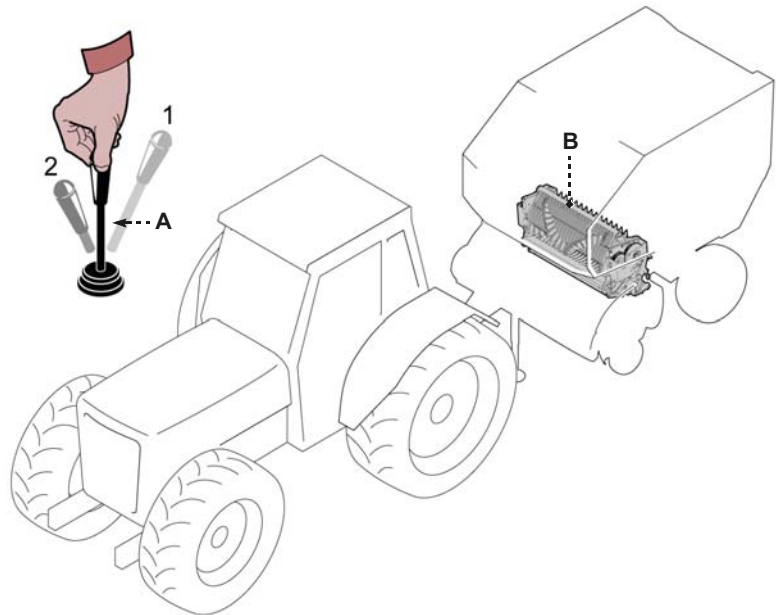

Follow the instructions.

- ▶ Act on the commands of the electronic control system to activate the controls of the "Drop floor" device.
- ▶ Move the lever (**A**) of the tractor's hydraulic control valve (from position **1** to position **2**) to lower the table of the "Drop floor" device (**B**) and unblock the feeding unit.
- ▶ Use the lever (**A**) to bring the table of the "Drop floor" device back to the "raised" position.
The electronic control system gives a signal when the position is reached..
- ▶ Act on the commands of the electronic control system to deactivate the controls of the "Drop floor" device.
- ▶ Activate the PTO to check whether the feeding unit has been cleared.

Feeding unit (powercut)

Positioning of knives

WARNING

Stop the tractor without shutting off the engine, engage the parking brake, and disconnect the power take-off.

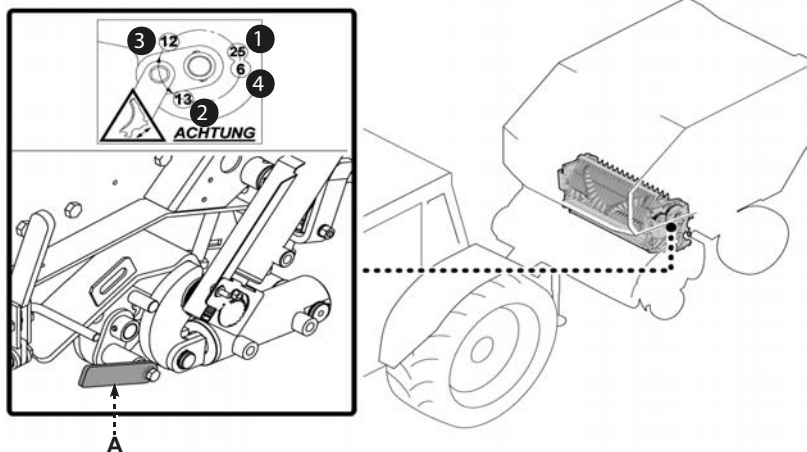

- ▶ The position of the knives must be adjusted on the basis of the hardness of the product harvested.
- ▶ Operate as indicated.
- ▶ Act on the commands of the electronic control system to bring the knives to the "extraction" position.
- ▶ Use lever (A) to select the number of knives to be used in the operating phase.
 - Position "1": 25 knives
 - Position "2": 13 knives (the knives in the odd-numbered positions are inserted)
 - Position "3": 12 knives (the knives in the even-numbered positions are inserted)
 - Position "4": 6 knives
- ▶ Act on the commands of the electronic control system to lift the knives.

Knives' replacement

WARNING

Stop the tractor without shutting off the engine, engage the parking brake, and disconnect the power take-off.

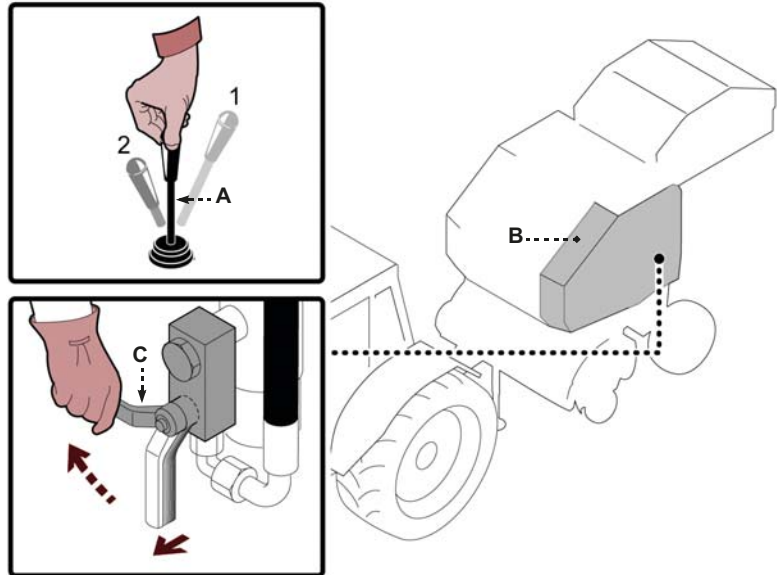

Follow the instructions.

- ▶ Act on the commands of the electronic control system to lower the knives completely.
- ▶ Bring the lever (A) on the tractor's hydraulic control valve to position 1 to open the tailgate.
- ▶ Act on the commands of the electronic control system to activate the controls of the "Drop floor" device.
- ▶ Use the lever of the tractor's hydraulic control valve to lower the table of the "Drop floor".
- ▶ Shut off the engine and remove the ignition key.
- ▶ Open the guard (B).
- ▶ Close the safety valve(C) to ensure safe working conditions.

CAUTION

Wear protective gloves in order to avoid the risk of cutting your hands.

Feeding unit (powercut)

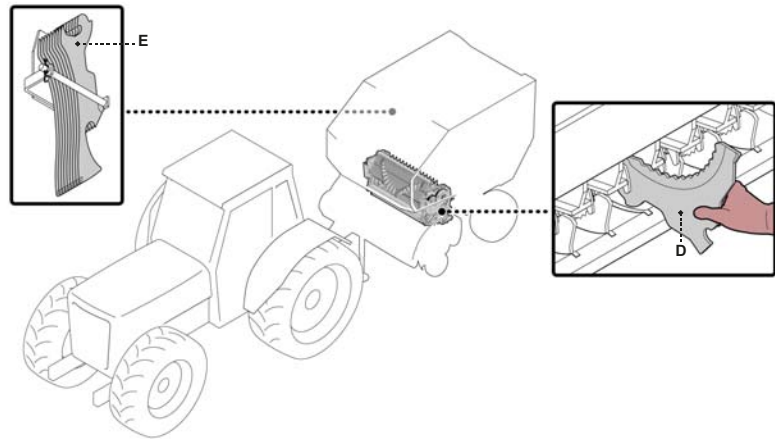

- ▶ Slide out the knives (**D**) and replace them.
 - ▶ Open the safety valve(**C**)
 - ▶ Close the guard(**B**)
 - ▶ Restart the tractor's engine.
 - ▶ Use the lever of the tractor's hydraulic control valve to lift the table of the "Drop floor".
 - ▶ Bring the tractor's hydraulic control valve lever (**A**) to position **2** to close the tailgate.
 - ▶ Act on the commands of the electronic control system to lift the knives.
-
- **The procedure described can be adopted also to decrease the number of knives (lightly chopped product) or to eliminate them completely (non-chopped product).**
 - **Assemble the replacement plates (E) at the points at which all or part of the knives (D) were removed, to prevent plugging and/or accumulations in the slots of the feeding table.**
 - **The replacement plates are in a kit supplied on request; it is to be located on the right hand side.**

Sharpening of knives

WARNING

Stop the tractor without shutting off the engine, engage the parking brake, and disconnect the power take-off.

- The product must be cut cleanly to ensure that it is fed correctly..
- If the product is not being fed correctly, check the conditions of the knives to assess whether they need sharpening.
- The conditions of the knives depend on the operating conditions and on the type of product being cut.
- In any case, the knives must be sharpened every 500 bales formed.

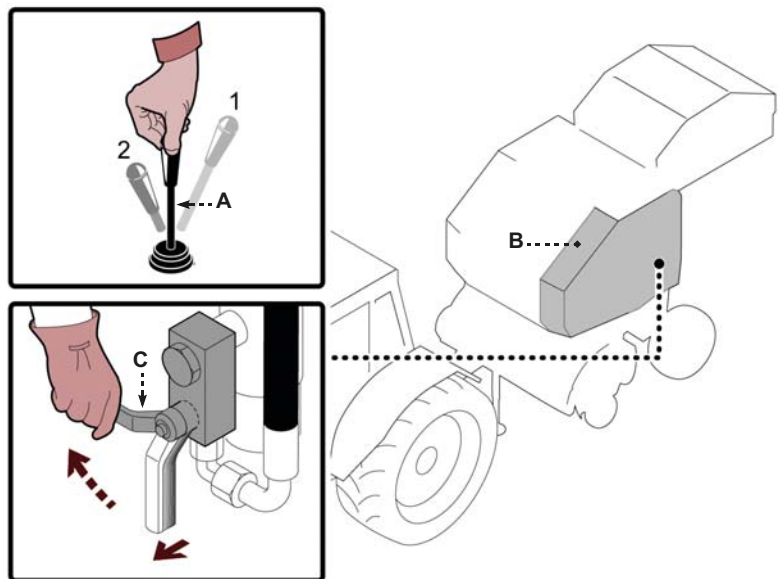

Follow the instructions.

- ▶ Act on the commands of the electronic control system to lower the knives completely.
- ▶ Bring the lever (**A**) on the tractor's hydraulic control valve to position **1** to open the tailgate.
- ▶ Act on the commands of the electronic control system to activate the controls of the "Drop floor" device.
- ▶ Use the lever of the tractor's hydraulic control valve to lower the table of the "Drop floor" device.
- ▶ Shut off the engine and remove the ignition key.
- ▶ Open the guard (**B**).
- ▶ Close the safety valve(**C**) to ensure safe working conditions.

Feeding unit (powercut)

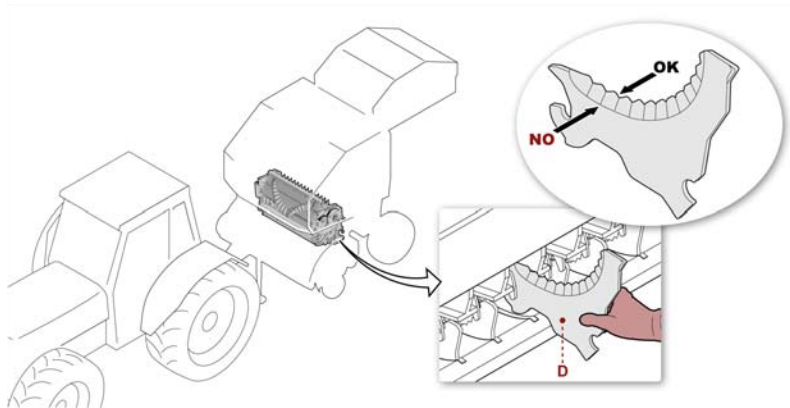

CAUTION

Wear protective gloves in order to avoid the risk of cutting your hands.

- ▶ Slide out the knives (D).
- ▶ Sharpen the knives.

NOTICE

They must be sharpened only on the smooth side as indicated in the figure.

- **To sharpen the knives, use a grinder and avoid overheating, to prevent irreparable damage to the temper of the knives.**
- ▶ Reassemble the knives.
- ▶ Open the safety valve(C).
- ▶ Close the guard(B).
- ▶ Restart the tractor's engine.
- ▶ Use the lever of the tractor's hydraulic control valve to lift the table of the "Drop floor".
- ▶ Act on the commands of the electronic control system to deactivate the controls of the "Drop floor" device.
- ▶ Bring the tractor's hydraulic control valve lever (A) to position 2 to close the tailgate.
- ▶ Act on the commands of the electronic control system to lift the knives.

General description

The net binding unit quickly winds the bale up to the edges so that it becomes solid and compact.

For information on the binding unit's programming, operating modes, etc., please refer to the chapter on how to use the machine.

The illustration shows the net's path during bale binding operations.

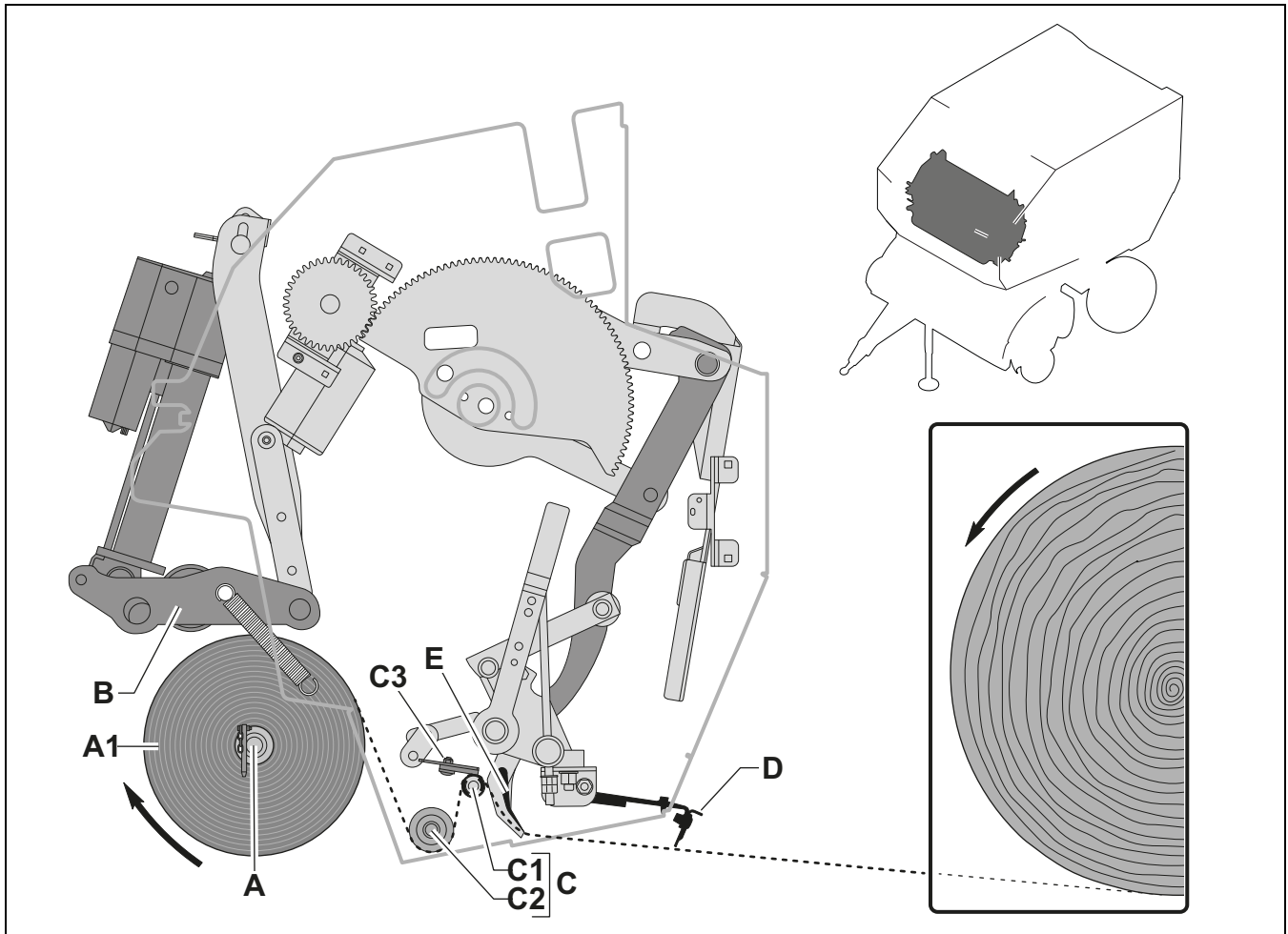

- A) **Support:** supports the net reel (A1).
- B) **Braking device:** keeps the net reel (A1) taut during the binding phase.
- C) **Net guide rollers:** guide the net inside the baling chamber. The brake (C3) rests on the roller (C1) when the binding phase is complete in order to ensure that the net is cut correctly and regularly.
- D) **Cutting device:** automatically cuts the net at the end of the binding cycle based on the parameters set using the electronic control system.

WARNING

The device is fitted with an extremely sharp cutting blade, which is necessary to cut the net in a precise and clean manner.

Wear protective gloves in order to avoid the risk of cutting your hands.

ONLY carry out inspection and maintenance operations after having deactivated the cutting device (See “Cutting device activation and deactivation”).

- E) **Net insertion device:** inserts the binding element into the baling chamber.

Electrical devices

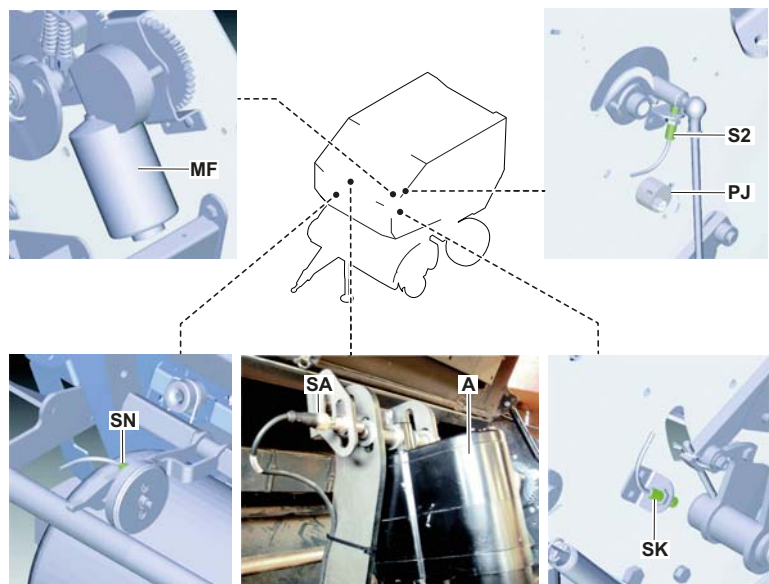

- A) **Electrical linear actuator:** activates net braking device.
MF) **Electric motor:** drives the net/twine insertion device.
PJ) **Potentiometer:** detects the position of the net/twine insertion device.
S2) **Sensor:** detects the position of the net/twine insertion device (front limit stroke), enables the stoppage of the electric motor (MF), and resets the system.
SA) **Sensor:** detects the position of the net braking device.
SK) **Sensor:** detects the end of the binding cycle.
SN) **Sensor:** detects the quantity of net that has been unrolled.

Re-stocking the net reel

WARNING

Stop the tractor with the engine running, engage the parking brake, and disconnect the power take-off.

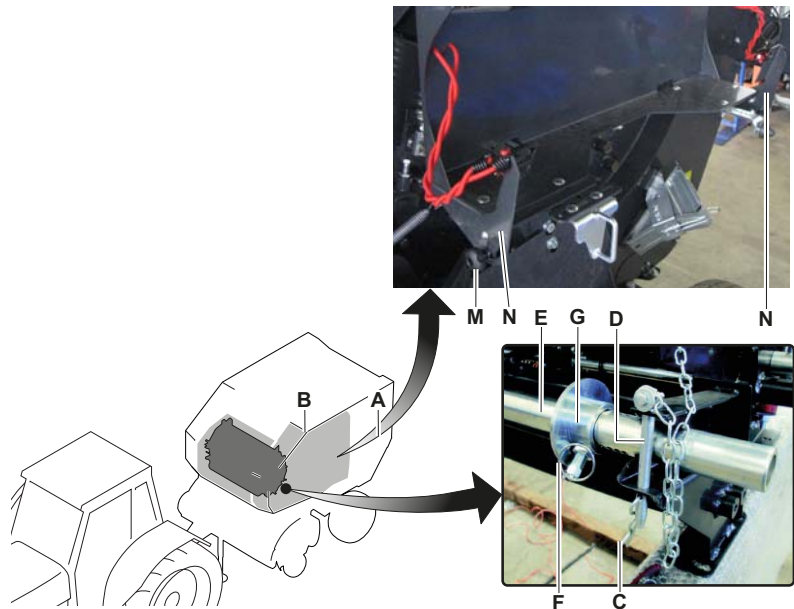

- ▶ Lift braking device using the electronic control system.
- ▶ Shut off the engine and remove the ignition key.
- ▶ Open the guards (A-B).
- ▶ Remove the split pin (C) and extract the pin (D).
- ▶ Rotate the reel support (E) and disengage the knob (F) from the reel support to remove the catch (G).
- ▶ Extract the cardboard core from the roll.
- ▶ Loosen the knob (M).
- ▶ Lower the support (N).
- ▶ Repeat the operation on the other identical component.
- ▶ Take the new roll and mount it on the support (E).
- ▶ Place a new backup roll inside the housing, in a central position with respect to the supports (N).
- ▶ Raise the support (N).
- ▶ Tighten the knob (M).
- ▶ Repeat the operation on the other identical component.
- ▶ Insert the catch (G) and insert the knob (F).
- ▶ Be sure to leave an axial clearance of 3/5 mm (0.12"/0.2").
- ▶ Position the support (E) with the new reel.
- ▶ Reinsert the pin (D) and the split pin (C).
- ▶ Check that the reel is centered with respect to the baling chamber and adjust its position if necessary.
To center the reel, disengage the knobs (F) on the catches (G), manually move the reel, and re-insert the knobs (F) to lock the catches (G) in place.

NOTICE

In order to make sure that the net unwinds properly, check that the reel's cardboard core is in good condition (without damage and/or wet areas).

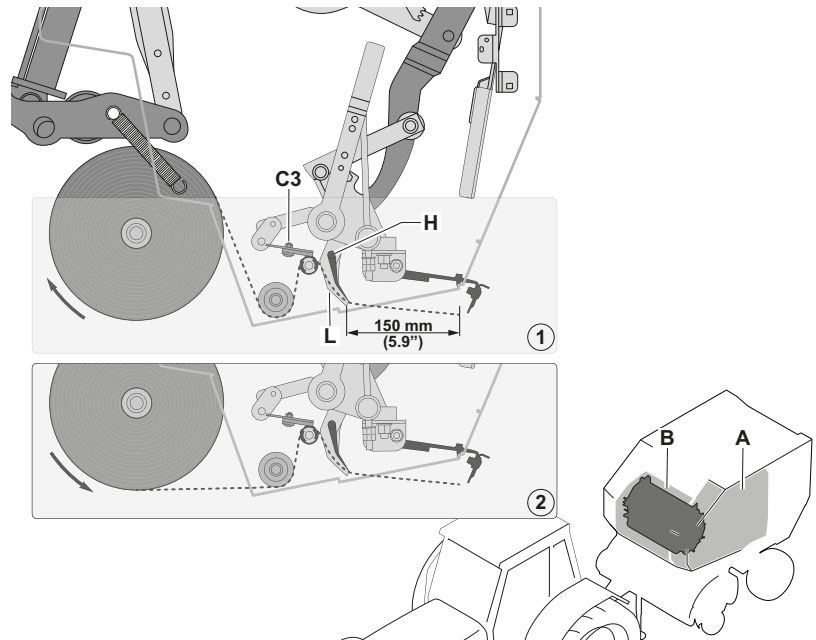

- ▶ Raise the floating sector (H).
- ▶ Unroll the net along the path shown in figure 1 and insert it into the net insertion device (L), into the special slot on the left side of the brake (C3).
- ▶ Insert a sufficient amount of net and let it protrude by about 15 cm (5.9").
Make sure that the net is fastened to the upper teeth of the net insertion device (L).
- ▶ Lower the floating sector (H).
- ▶ Lower the braking device using the electronic control system.
- ▶ Close the guards (A-B).

Before closing the guards, make sure that the backup net roll has been properly centered and is blocked in its raised position by the appropriate supports (N).

NOTICE

If the net tends to spread excessively during the binding operation, change the unwinding direction (see the illustration, path 2).

Adjusting the braking device

WARNING

Make sure the tractor's PTO is disengaged.
Turn off the engine, engage the parking brake, and remove the ignition key.

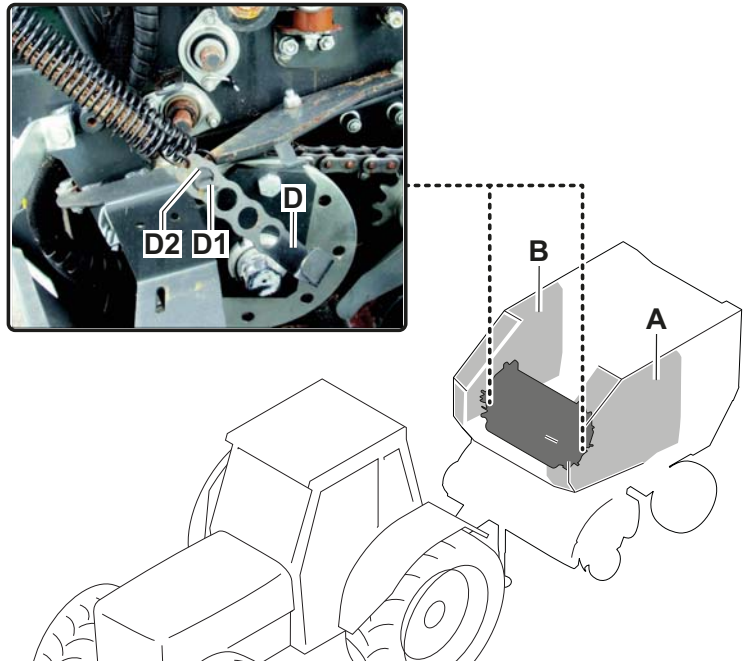

- In order to operate properly, the braking device must be leaning against the reel.
If the braking action proves to be unsuitable, follow the instructions.
- ▶ Open the guards (A-B).
- ▶ Use the holes present on the bracket (D) in relation to the pin (D1) to modify its position in order to obtain a different braking action.
 - Recommended position (D2).
- ▶ Repeat the operation on the other bracket.
- ▶ Close the guards (A-B).

PowerBind net binder

Adjusting the cut reset device

WARNING

Stop the tractor with the engine running, engage the parking brake, and disconnect the power take-off.

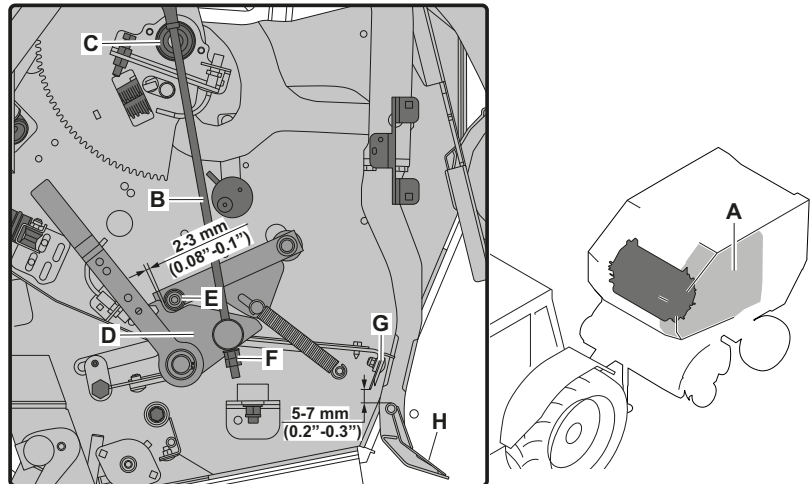

- ▶ Open the guard (A).
- ▶ Position the tie rod (B) in line with the bearing (C) using the electronic control system.
- ▶ Shut off the engine and remove the ignition key.
- ▶ Adjust the distance between the support (D) and the bearing (E) using the nut (F).
- ▶ Make sure that the distance between the cutting blade (G) and the net insertion device (H) is correct.
If necessary, modify the distance between the support (D) and the bearing (E).
- ▶ Close the guard (A).

Adjusting the shockproof springs

WARNING

Make sure the tractor's PTO is disengaged.
Turn off the engine, engage the parking brake, and remove the ignition key.

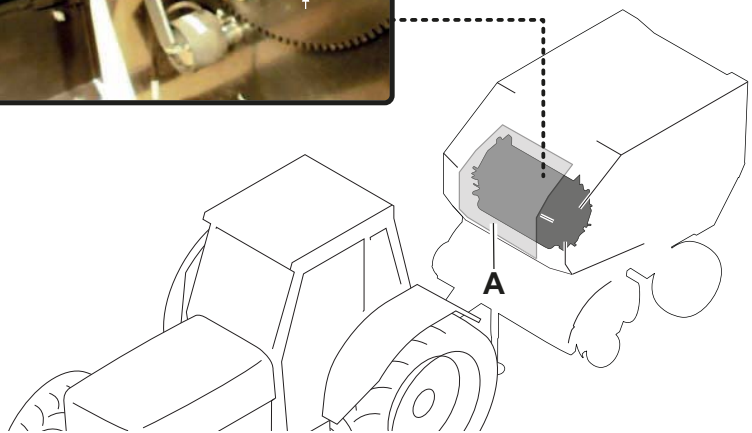
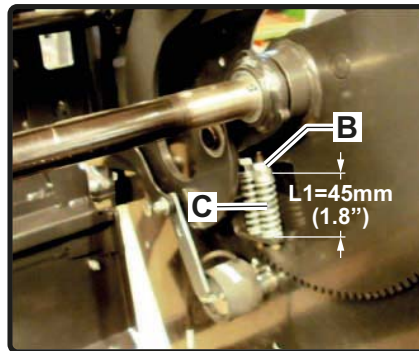

- ▶ Open the guard (A).
- ▶ Use the nuts (B) (and the relative locknuts) to adjust the pressure of the springs (C).

NOTICE

The length (L) must be set to the value shown in the figure in order to adjust the springs.

- ▶ Close the guard (A).

PowerBind net binder

Adjusting the compensation springs

WARNING

Make sure the tractor's PTO is disengaged.
Turn off the engine, engage the parking brake, and remove the ignition key.

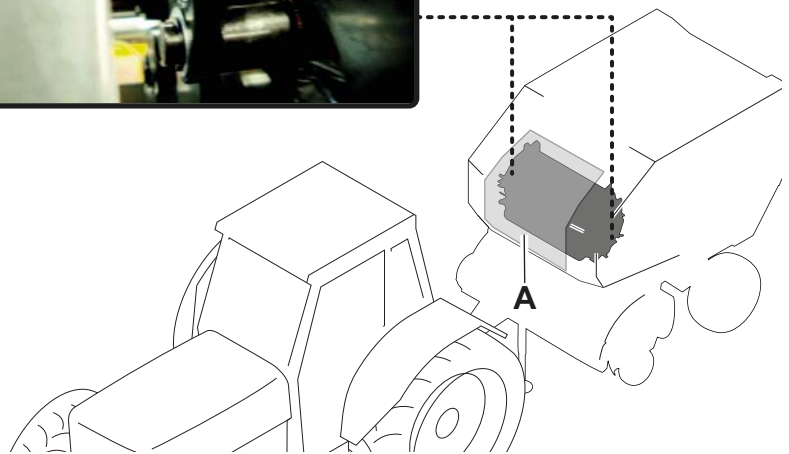
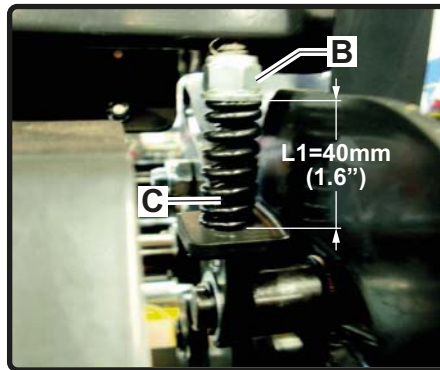

- ▶ Open the guard (A).
- ▶ Use the nut (B) to adjust the pressure of the spring (C).
- ▶ Repeat the operation on the other identical component.

NOTICE

The length (L) must be set to the value shown in the figure in order to adjust the springs.

- ▶ Close the guard (A).

Adjusting the RESET/START position sensor

WARNING

Stop the tractor with the engine running, engage the parking brake, and disconnect the power take-off.

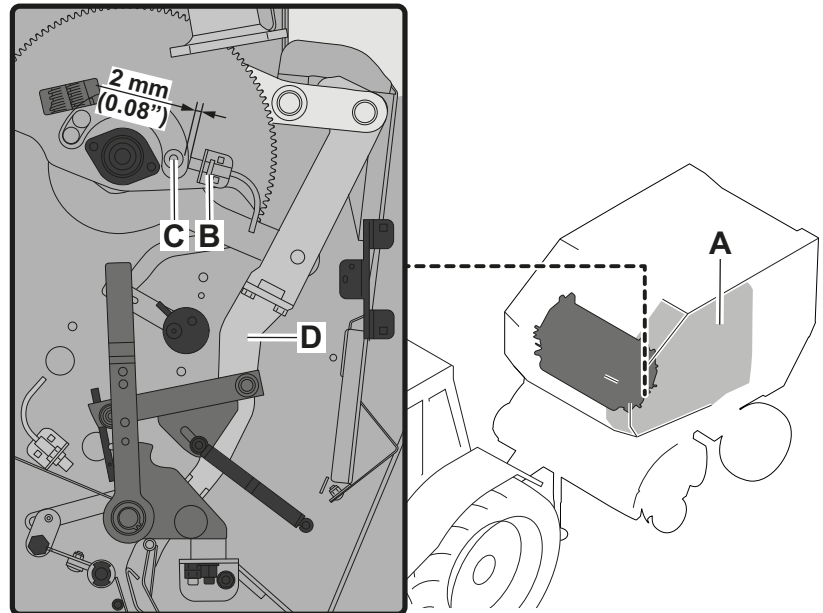

- ▶ Set the net/twine insertion device (**D**) to the reset position using the electronic control system's controls.
- ▶ Shut off the engine and remove the ignition key.
- ▶ Open the guard (**A**).
- ▶ Adjust the distance between the sensor (**B**) and the pin (**C**) using the nuts.
- ▶ Close the guard (**A**).

PowerBind net binder

Cutting device activation and deactivation

WARNING

Make sure the tractor's PTO is disengaged.
Turn off the engine, engage the parking brake, and remove the ignition key.

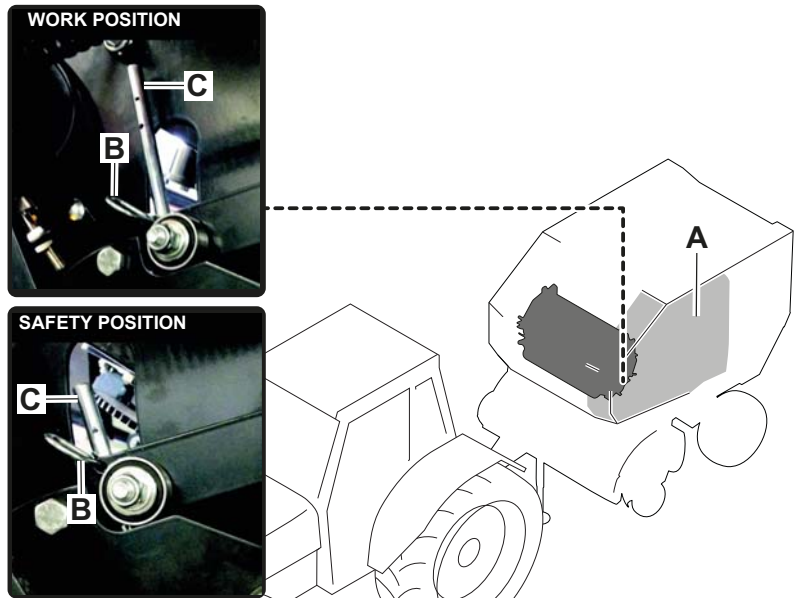

- ▶ Open the guard (A).
- ▶ Remove the split pin (B), insert the pin (C) in the SAFETY POSITION, and then insert the split pin.
- ▶ Perform the necessary operations.
To re-activate the cutting device at the end of the aforesaid operations, remove the split pin (B), insert the pin (C) in the WORKING POSITION, and then insert the split pin.
- ▶ Close the guard (A).

Twine binding unit (electronic)

General description

The twine binding unit binds the bale with spirals of twine in order to render the bale solid and compact.

For information on the binding unit's programming, operating modes, etc., please refer to the chapter on how to use the machine.

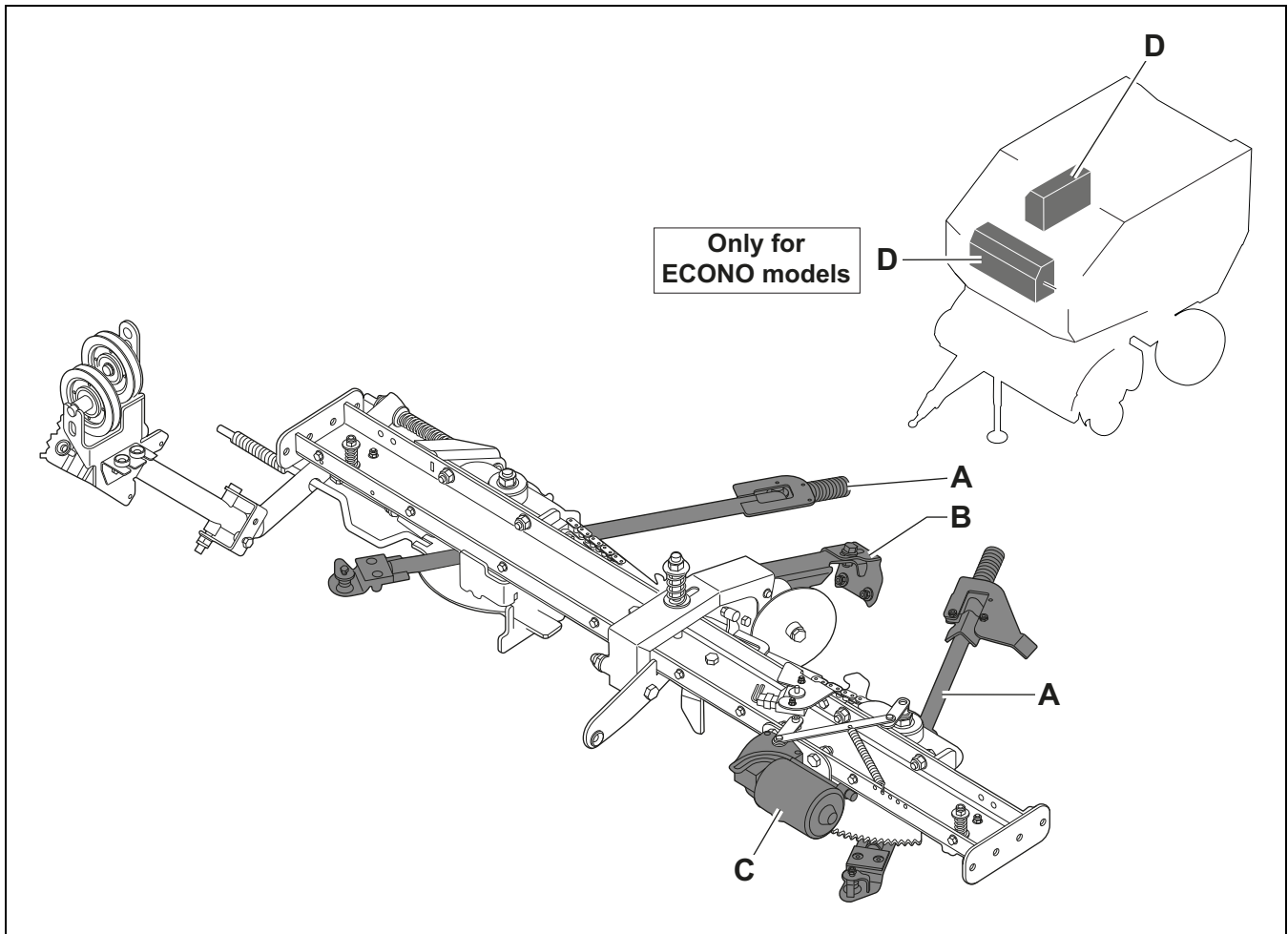

- A) **Twine guide arm:** distributes the twine over the bale in simultaneous and opposite manner with respect to the other guiding arm. The electronic control system sets the winding mode and the quantity of twine.
- B) **Cutting arm:** automatically cuts the twine at the end of the binding operation.
- C) **Transmission unit:** transmits the simultaneous and opposite motion to the twine guide arms (**A**) via the gear motor.
- D) **Twine compartment:** contains several twine reels, which are inter-connected in such a way as to work with a considerable degree of autonomy.

Twine binding unit (electronic)

Electrical devices

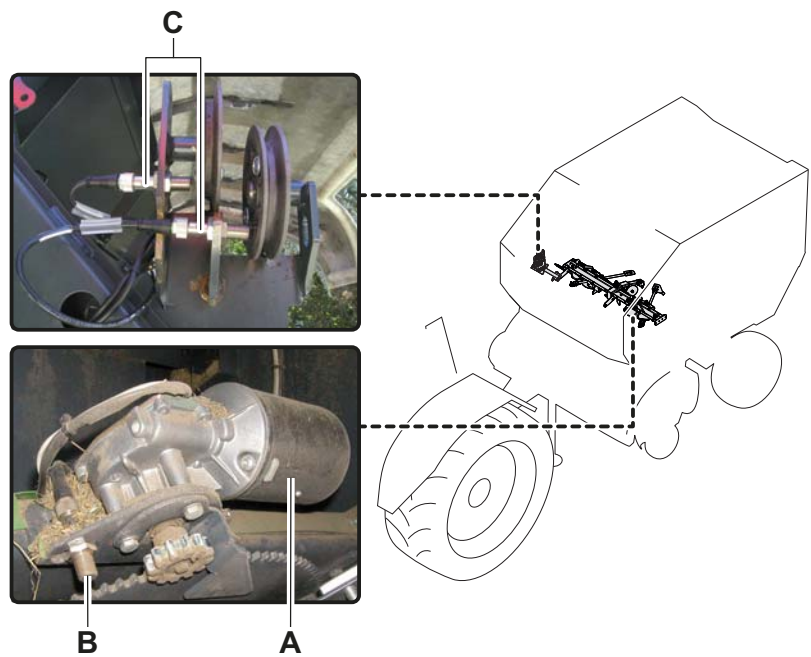

- A) **Electrical motor:** conveys the motion to the twine guide arms.
- B) **Sensor:** indicates the position of the twine guide.
- C) **Sensor:** detects the rotation of the pulley to determine the quantity of twine that has been wound around the bale.

Twine binding unit (electronic)

Inserting twine

WARNING

Make sure the tractor's PTO is disengaged.
Turn off the engine, engage the parking brake, and remove the ignition key.

NOTICE

This operation should only be performed the first time the machine is started. In order to avoid having to repeat this operation, be sure to re-stock the reels before they completely run out of twine.

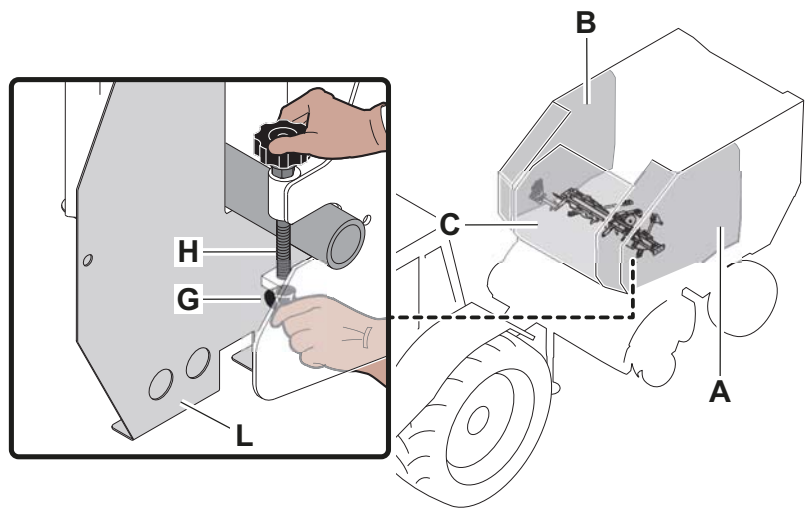

- ▶ Open the guards (A-B-C).
- ▶ Unscrew the nut (G), remove the hitch pin (H) and open the twine compartment (L) (Only perform this operation in the case of the frontal twine compartment).

Twine binding unit (electronic)

FRONTAL TWINE COMPARTMENT - DOUBLE LATERAL TWINE COMPARTMENT

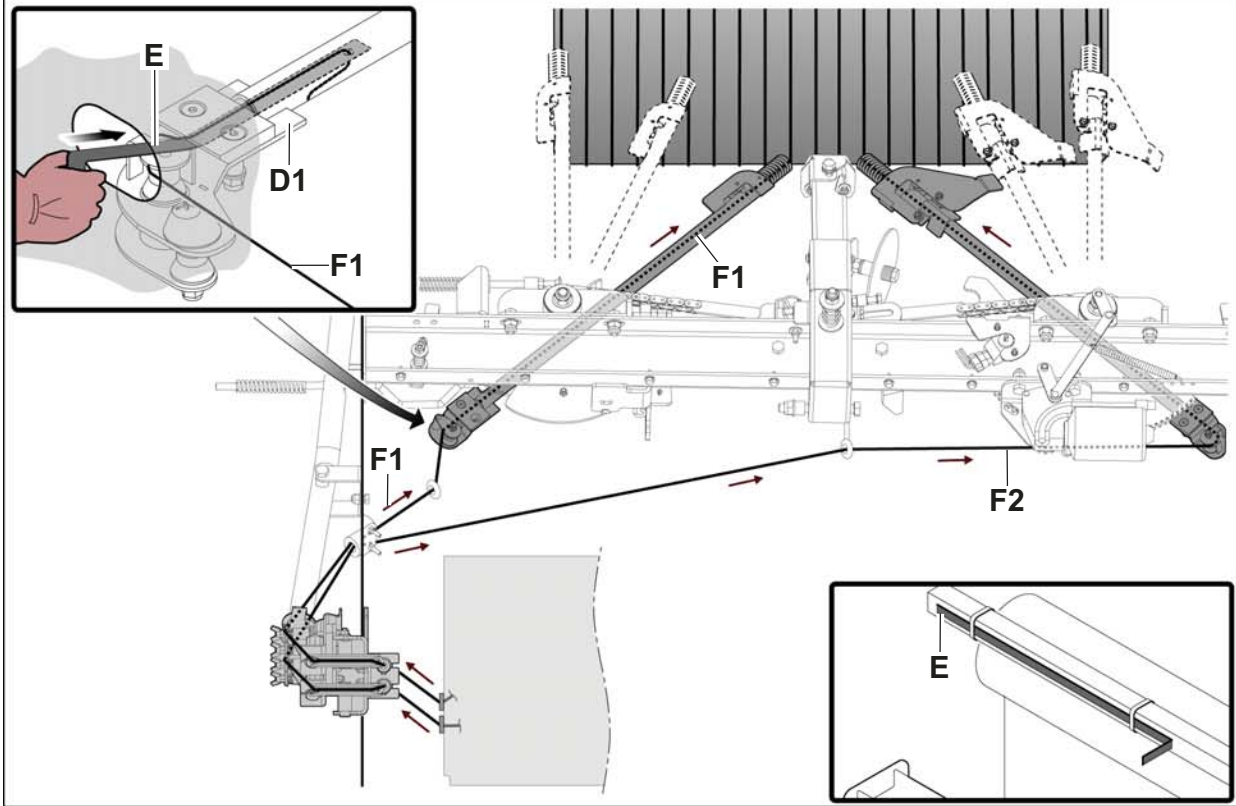

LATERAL TWINE COMPARTMENT

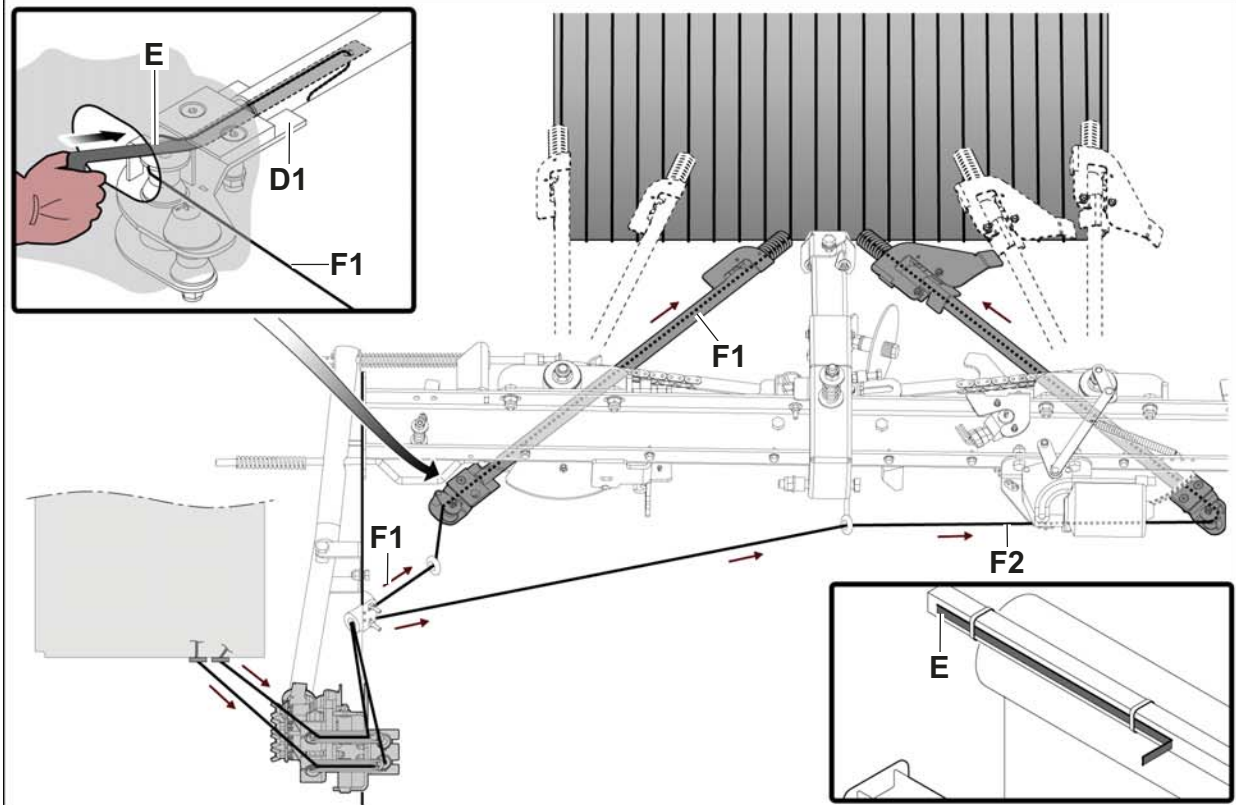

Twine binding unit (electronic)

- ▶ Unwind the strings of twine (**F1-F2**) according to the path shown in the figure.
- ▶ Insert the twine (**F1**) into the twine guide arm (**D1**) using the special tool (**E**).
To complete the twine insertion process, insert the tool (**E**) completely.

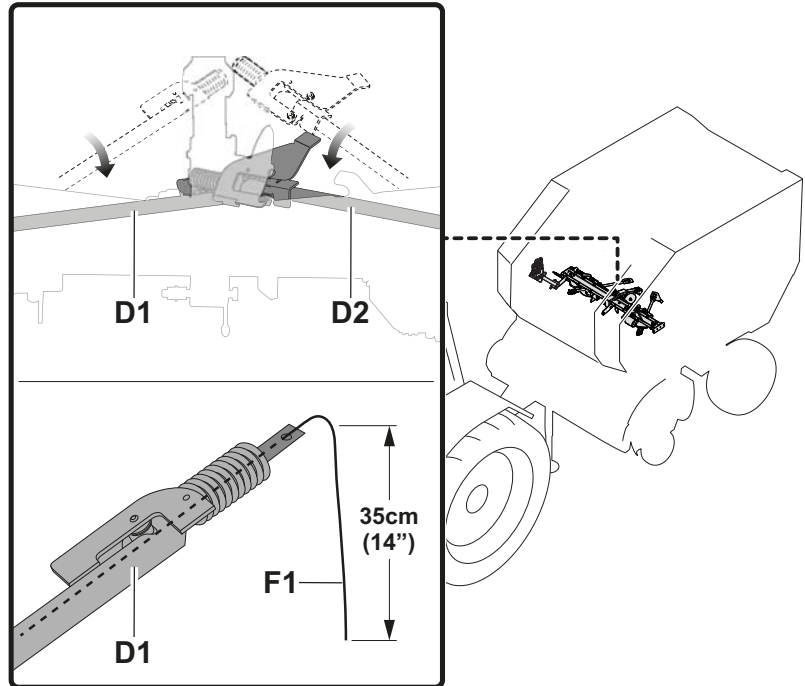

- ▶ Position the twine guide arms (**D1-D2**) so that they are overlapping (See "Using the machine").
- ▶ Deactivate the electronic control system.
- ▶ Pull on the twine (**F1**) and extract about 25-30 cm (10"-12") from the twine guide arm (**D1**).



NOTICE

When inserting the twine, leave about 35 cm (14") excess in the area in order to prevent the twine from being pulled back in and not gripping the bale during the arms' movement.

- ▶ Reactivate the electronic control system.

Twine binding unit (electronic)

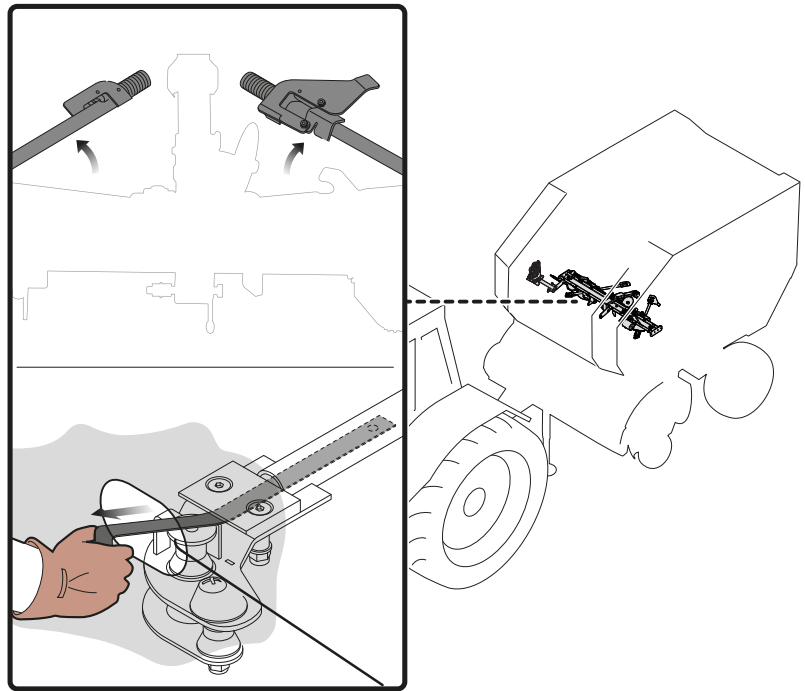

- ▶ Set the twine guide arms (**D1-D2**) to their initial position (See “Using the machine”).
- ▶ Remove the tool (**E**).
- ▶ Repeat the same operation to insert the twine (**F2**) into the twine guide arm (**D2**).
- ▶ Adjust the twine tightening clamps (See “Adjusting the twine tightening clamps”).
- ▶ At the end of the operation, position the twine guide arms at the point where the binding cycle starts (See “Using the machine”).
- ▶ Set the tool aside (**E**).

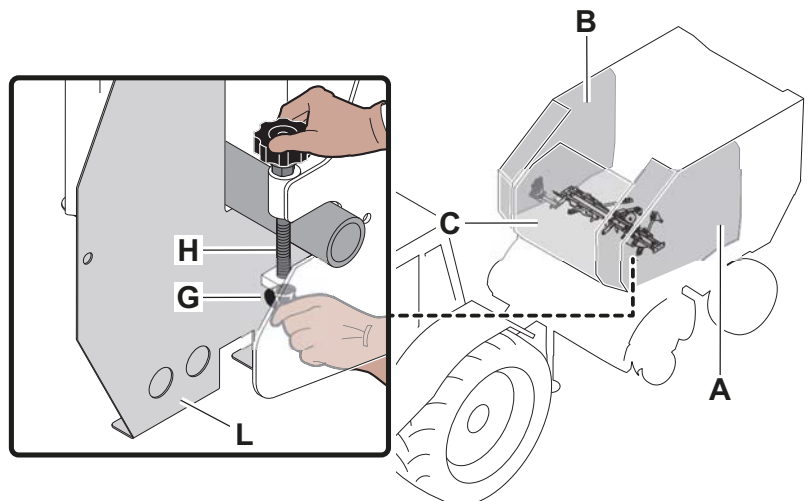

- ▶ Close the twine compartment (**L**), insert the hitch pin (**H**) and then tighten the nut (**G**) (Only perform the operation in the case of the frontal twine compartment).
- ▶ Close the guards (**A-B-C**).

Re-stocking the twine reels

NOTICE

In order to avoid having to repeat the twine insertion operation, it is necessary to prevent the machine from completely running out of twine reels. Periodically (every 4-6 hours or at the end of the working day) check to make sure that the twine compartment is stocked with twine reels.

WARNING

Make sure the tractor's PTO is disengaged. Turn off the engine, engage the parking brake, and remove the ignition key.

Follow the instructions.

CAUTION

Carry out the following procedure from the ground, without climbing onto the machine's parts.

- ▶ Open the guards.
- ▶ Insert the new reels into the twine compartment (**G-G1-G2**) in place of the finished ones, then tie them together. The twine compartment can be either of a lateral or frontal type. In the case of the frontal twine compartment, insert the rear reels first.

NOTICE

In order to prevent the twine from unwinding in a spiral fashion, the reels must be positioned with the wording on the package upright (not upside down).

Twine binding unit (electronic)

The reels (A1-A2-A3-A4) feed the twine guide arm (A), while the reels (B1-B2-B3-B4) feed the twine guide arm (B).

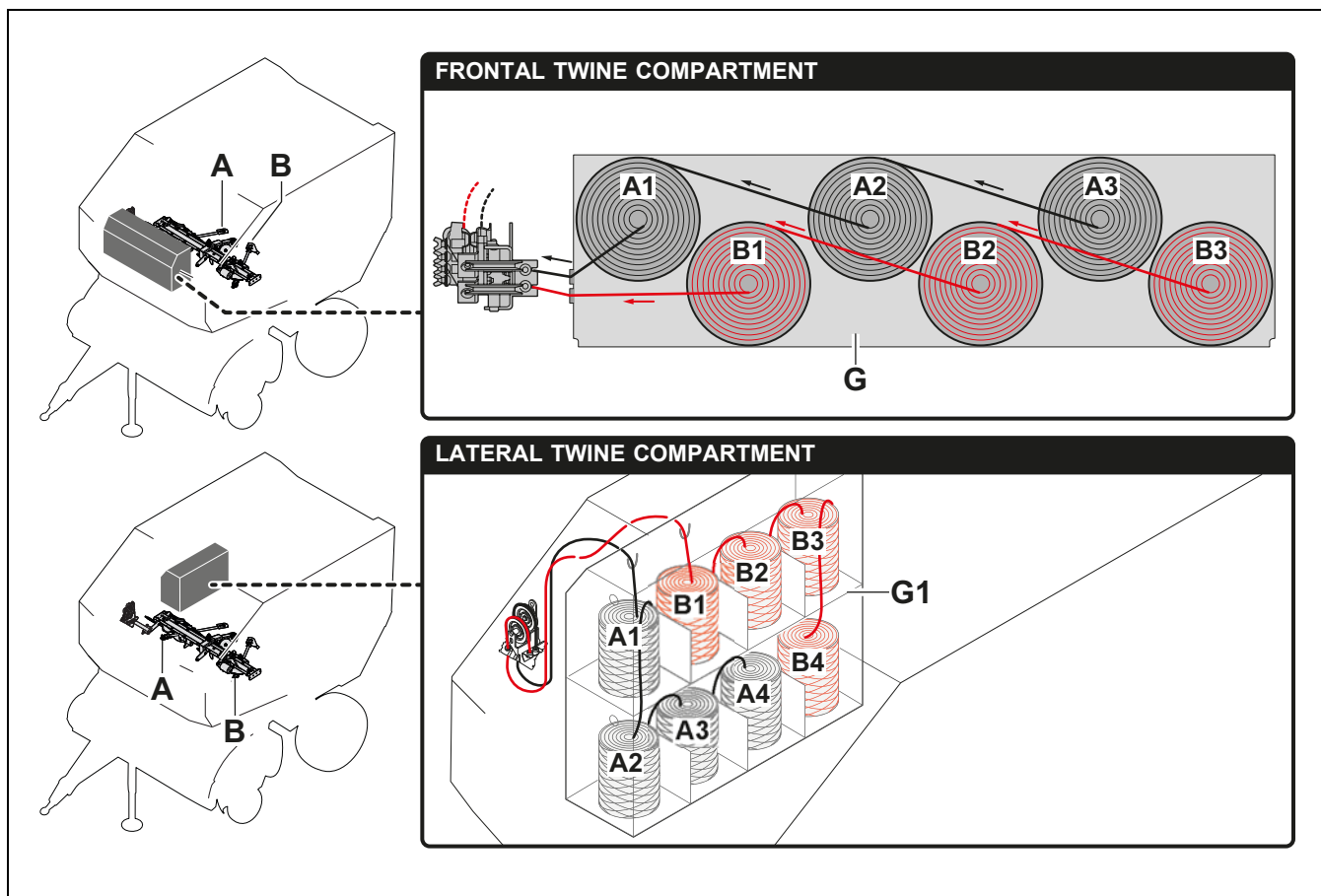

Twine binding unit (electronic)

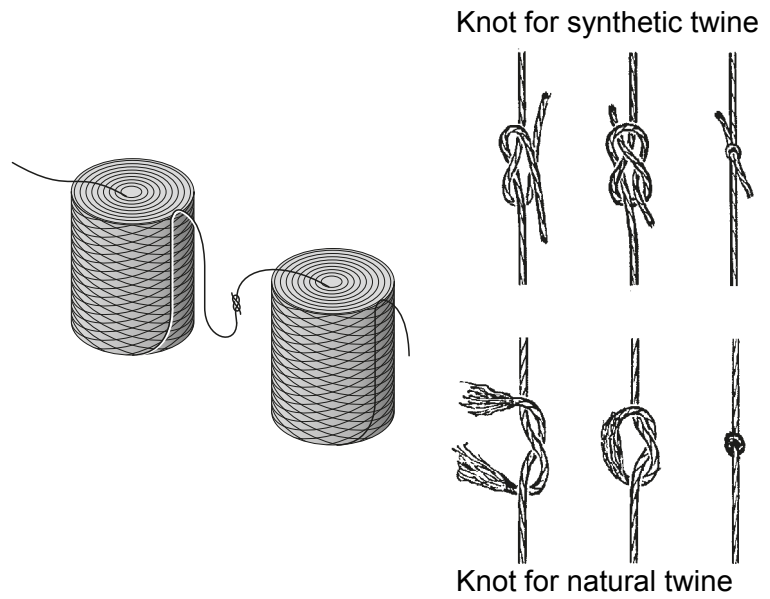

- ▶ In order to tie them together, tie the upper end of one reel to the lower end of the next reel.



NOTICE

In order to facilitate smooth running and prevent entanglement, connect the end of the twine as shown in the figure, making sure the knot is as small as possible.

- ▶ Close the guards.

Twine binding unit (electronic)

Adjusting the twine tightening clamps

WARNING

Make sure the tractor's PTO is disengaged.
Turn off the engine, engage the parking brake, and remove the ignition key.

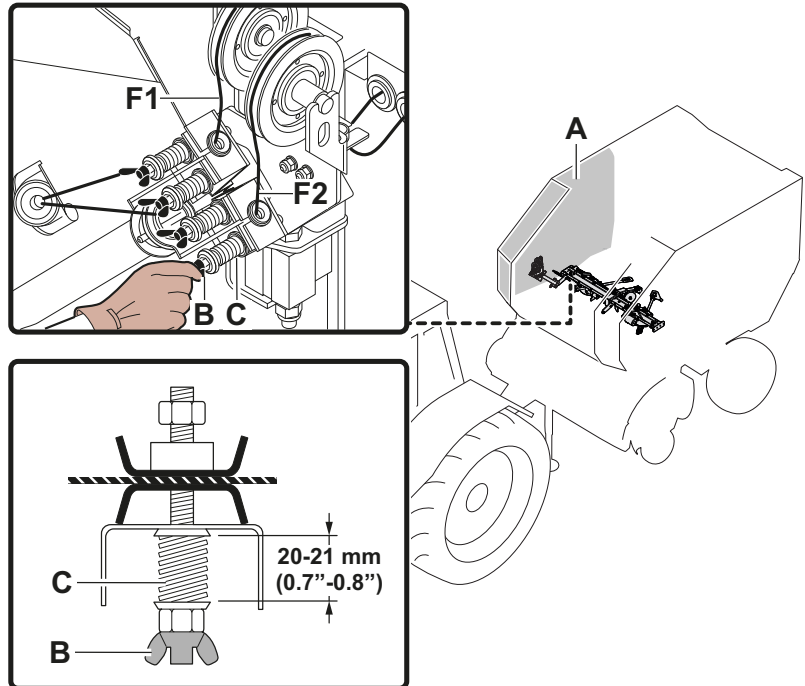

- ▶ Open the guard (A).
- ▶ Adjust the tension of the springs (C) using the nuts (B).

NOTICE

To make sure that the strings of twine (F1-F2) run freely, apply a force of 20-30 N.

NOTICE

Certain types of twine might require less tension than the indicated one.

- ▶ Close the guard (A).

Twine binding unit (electronic)

Adjusting the chains on the twine guide arms

WARNING

Make sure the tractor's PTO is disengaged.
Turn off the engine, engage the parking brake, and remove the ignition key.

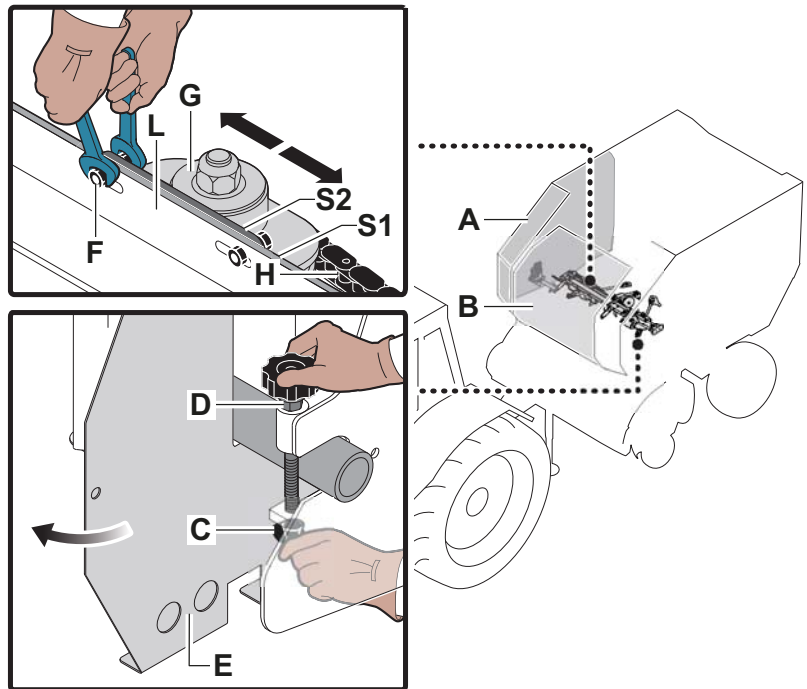

- ▶ Open the guards (A-B).
- ▶ Unscrew the nut (C), remove the hitch pin (D) and open the twine compartment (E) (Only perform the operation in the case of the frontal twine compartment).
- ▶ Loosen the screws (F).
- ▶ Use the support (G) to adjust the tension of the chain (H).

NOTICE

In order to position the twine guide arms properly, the supporting surfaces (S1-S2) of the support (G) and of the frame (L) must be parallel.

CAUTION

Do not tighten the transmission too much in order to avoid damaging the rotating devices.

- ▶ Tighten the screws (F).
- ▶ Close the twine compartment (E), insert the hitch pin (D), and tighten the nut (C) (Only perform the operation in the case of the frontal twine compartment).
- ▶ Close the guards (A-B).

Twine binding unit (electronic)

NOTICE

In order to obtain good performance from the binding unit, carry out periodic checks to keep all the operating areas clean.

Replacing the blade

WARNING

Make sure the tractor's PTO is disengaged. Turn off the engine, engage the parking brake, and remove the ignition key.

CAUTION

Wear protective gloves in order to avoid the risk of cutting your hands.

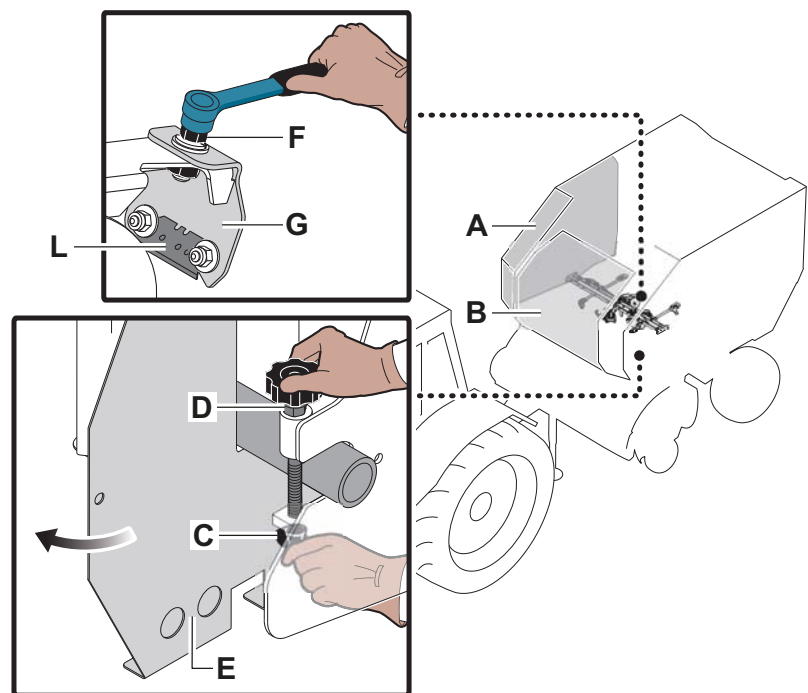

- ▶ Open the guards (A-B).
- ▶ Unscrew the nut (C), remove the hitch pin (D) and open the twine compartment (E) (only perform the operation in the case of the frontal twine compartment).

NOTICE

Before removing the blade's support (G), mark the area that enters into contact with the structure of the cutting arm in such a way as to identify the position and the correct coupling for the re-assembly phase.

- ▶ Unscrew the screws (F) to remove the support (G).

Twine binding unit (electronic)

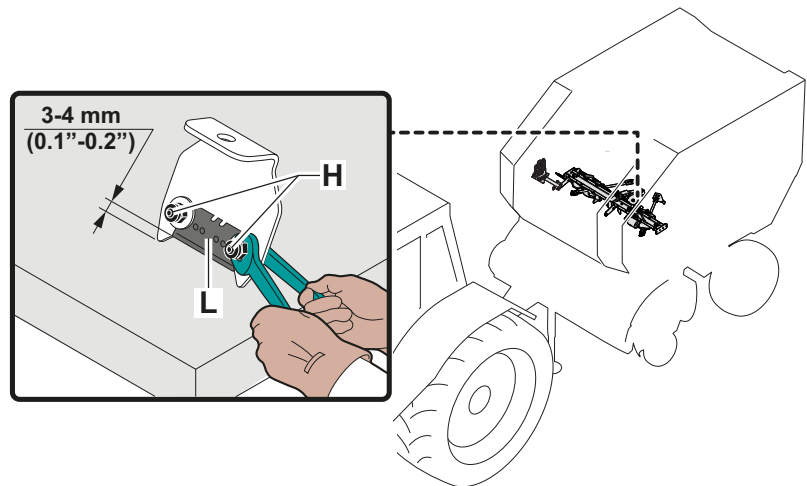

- ▶ Unscrew the screws (**H**) to remove the worn blade (**L**).
- ▶ Install the new blade and fasten it in place with the screws (**H**) (respect the distance shown in the figure).
- ▶ Reinstall the support (**G**) in the previous position, and fasten it in place with the appropriate screws.
- ▶ Close the twine compartment (**E**), insert the hitch pin (**D**), and tighten the nut (**C**) (Only perform the operation in the case of the frontal twine compartment).
- ▶ Close the guards (**A-B**).

Page intentionally left blank

Page intentionally left blank

A01 - Wiring diagrams

ESD A01 - GENERAL DIAGRAM OF ELECTRICAL SYSTEM

Table 1: Electrical system components

Code	Designation	Photograph No.
A	Linear actuator for net roll brake	8
BCT	Control unit	1
ECU	Control unit	2
HL	Left hook sensor	14
HR	Right hook sensor	3
MF	Swing motor	11
MT	Twine binder motor	9
PA	Linear actuator potentiometer	8
PB	Bale diameter potentiometer	15
PF	Direction indicators potentiometer	16
PJ	Net insertion arm potentiometer	13
S2	Reset/start position sensor	13
SA	Net roll brake sensor	8
SB	Twine binding fine sensor	9
SC	Supercut sensor	4
SD	"Drop-floor" sensor	5
SF	Swing motor sensor	11
SK	Twine bribes pulley sensor	10
SM	Maximum bale diameter sensor	15
SN	Net meter sensor	12
SP	Twine binder pulley sensor	6
ST	Twine binder motor sensor	9
V0	Bypass solenoid valve	17
VD	"Drop floor" solenoid valve	7
VP	Pick-up unit solenoid valve	7
VS	Supercut solenoid valve	7
VR	Proportional solenoid valve for hydraulic block	17

	length(mm)
A136036100 BB 3GE RV51	2200
1. SENSOR CABLE HOOK RIGHT	3500
2. SENSOR CABLE HOOK LEFT	1500
3. SENSOR CABLE MAX BALE	3000
4. DENSITY BYPASS	3000
5. PROPORTIONAL RELIEVE	6000
6. ISO CABLE	350
7. SENSOR BAILE SIZE	1600
8. SENSOR CABLE BAILE SIZE	350
9. SENSOR SHAPE INDICATOR	5700
10. SENSOR SHAPE INDICATOR	
11. CABLE GLAND NUT M12	
12. SENSOR M18	
13. STORAGE SHEET BALER GALING	
14. POWER CABLE EUROPE	7000
15. BATTERY CABLE EUROPE	5000
16. POWER CABLE USA	7000
17. BATTERY CABLE USA	5000
18. MT00002803 SET SENSOR SHAPE INDICATOR	
19. SENSOR SHAPE INDICATOR	350
20. 4X SENSOR M12	5700
21. 4X SENSOR M12	
22. SENSOR CABLE RESET/START POS.	2600
23. SENSOR CABLE NET KNIFE	3000
24. SENSOR CABLE NET PULSE	3000
25. SENSOR CABLE NET BRAKE	1750
26. SENSOR INJECTION ARM	350
27. SENSOR CABLE INJECTION ARM	3500
28. MT00001606 SET TWINE BINDING	
29. SENSOR CABLE TWINE END POSITION	3500
30. SENSOR M12	
31. MT00001607 SET CUTTING#4	
32. SENSOR CABLE DROP FLOOR	3000
33. SENSOR CABLE SUPER CUT	3000
34. PICKUP VALVE	900
35. DROP FLOOR VALVE	900
36. SUPER CUT VALVE	900
37. MT00004808 SET CUTTING#5	
38. SENSOR CABLE DROP FLOOR	3000
39. SENSOR CABLE SUPER CUT	3000
40. PICKUP VALVE	900
41. DROP FLOOR VALVE	900
42. SUPER CUT VALVE	900
43. MT00001609 SET DROP FLOOR ROTOR	
44. SENSOR CABLE DROP FLOOR	3000
45. DROP FLOOR VALVE	900
46. MT00004840 SET TWINE PULSES	
47. SENSOR CABLE TWINE 1	1600
48. SENSOR CABLE TWINE 2	1600
49. SENSOR M12	
50. MT00001722 SET COVER VALVE CONNECTOR 18MM	
51. COVER VALVE CONNECTOR 18MM	
52. A136036200 SET SAFETY CATCH	2500
53. CABLE SENSOR GEARBOX	2500
54. CABLE SENSOR PHONIC WHEEL	3000
55. SENSOR M12	
56. A136036300 SET SHAPE INDICATORS 5FT BALER	
57. SENSOR SHAPE INDICATOR CENTRAL 5FT BALER	R0
58. SENSOR CABLE SHAPE INDICATOR	5700
59. SENSOR SHAPE INDICATOR RIGHT 5FT BALER	350
60. SENSOR CABLE SHAPE INDICATOR	5700
61. SENSOR SHAPE INDICATOR LEFT 5FT BALER	350
62. PILOT BOX FOCUS1	5700
63. CLAMP SET RAM	

MT00001607

MT00001609

MT00001640

MT00001722

A136036300

MT00001608

A136036200

MT00002803

A136005673

MT00001606

235

A01 - Wiring diagrams

ESD A03 - PERFORATION SCHEME FOR "CONTROL UNIT"
(ECU)

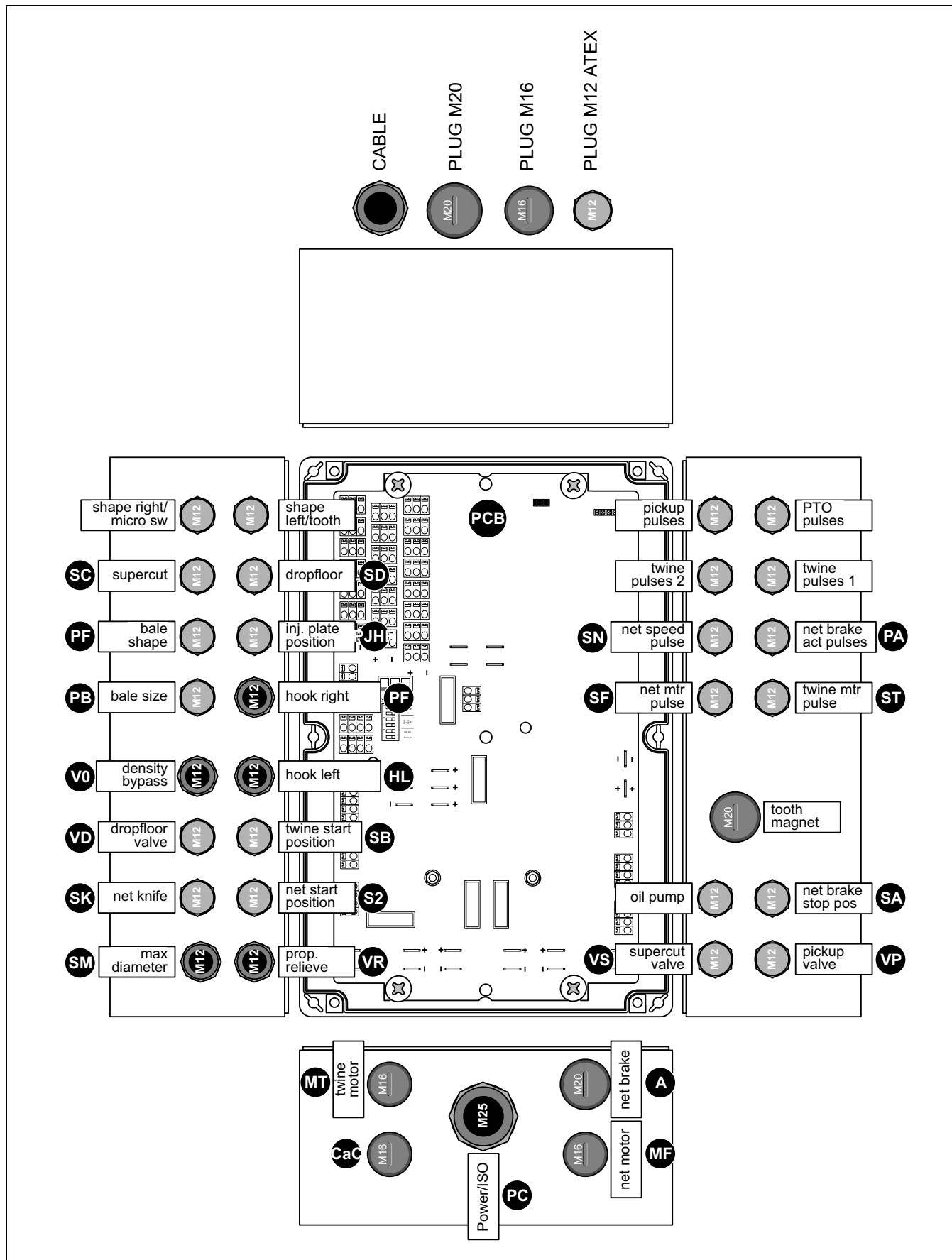

A01 - Wiring diagrams

ESD A04 - WIRING DIAGRAM AND DECAL FOR "CONTROL UNIT" (ECU)

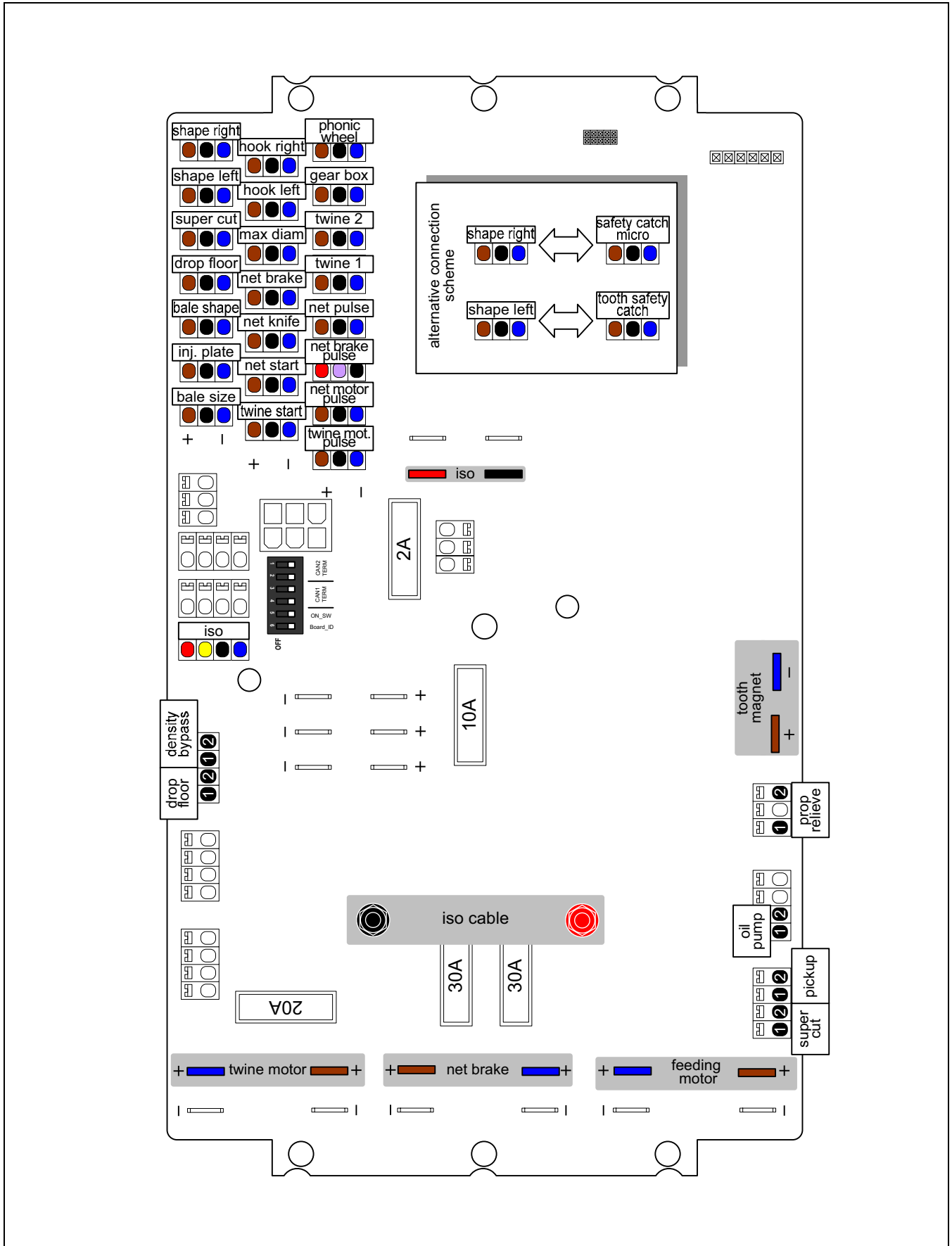

A01 - Wiring diagrams

ESD A05 - ISO CABLE FOR TRACTOR

	5		1	3 mtr	2		
	6		2		4		A
	7		3		1		
	8		4		3		
	9		5		4		
	10		6		2		B
	1		7		1		
	3		gr/ge		3		
	11		1	1 mtr	B		
	12		2		A		
	13		3		J		
	14		4		H		C
	15		5		D		
	16		gr/ge		C		

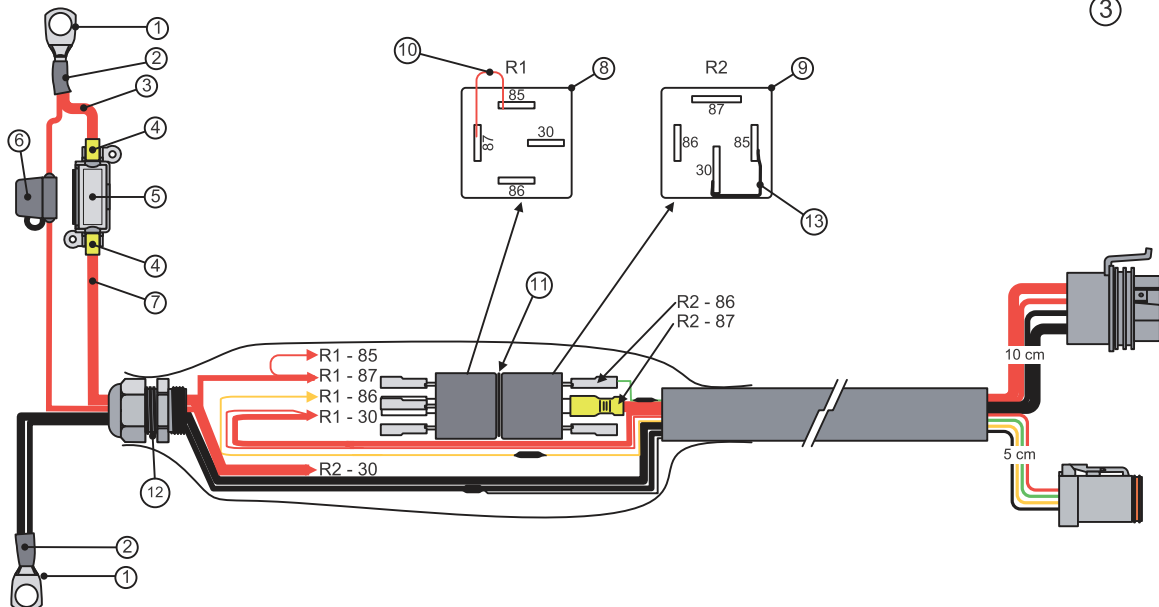
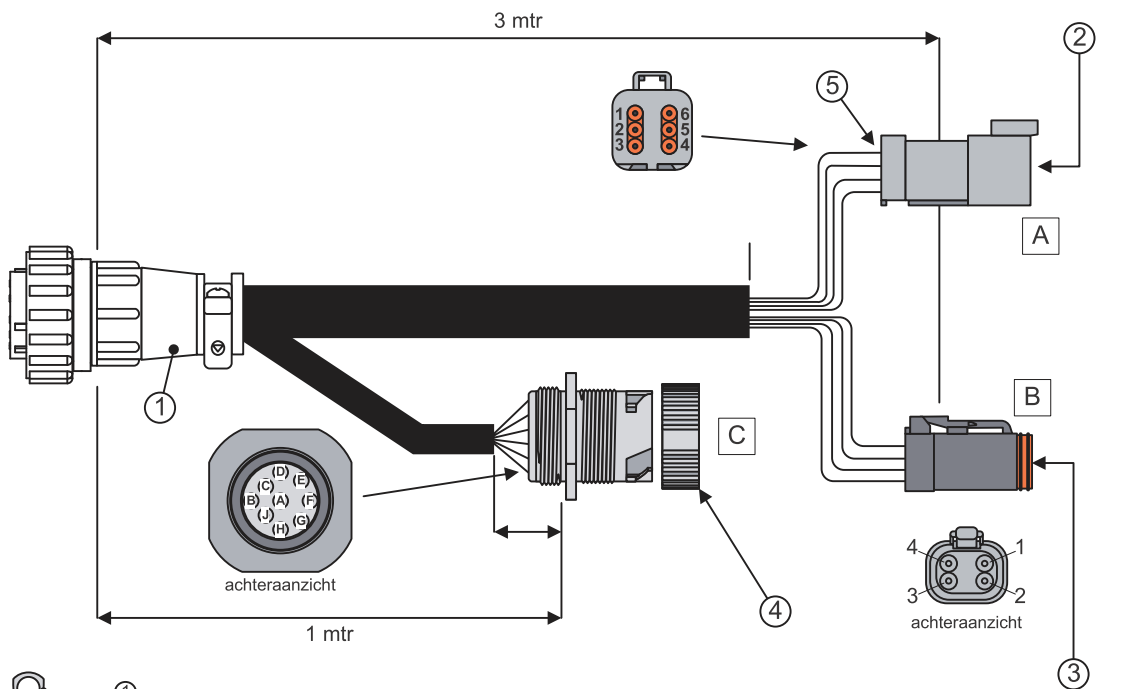

A01 - Wiring diagrams

ESD A06 - ISO CABLE

LINKS		VERBINDING				RECHTS			
connector	contact	kabel	kleur	lengte	draad diameter	contact	pos	connector	function
			red	6 mtr	6 mm ²		3		ACT PWR
			black		6 mm ²		1		ACT GND
			red		2,5 mm ²		4		ECU PWR
			black		2,5 mm ²		2		ECU GND
			red		0,5 mm ²		6		BC PWR
			black		0,5 mm ²		7		BC GND
			yellow		0,5 mm ²		8		CAN H
			green		0,5 mm ²		9		CAN L

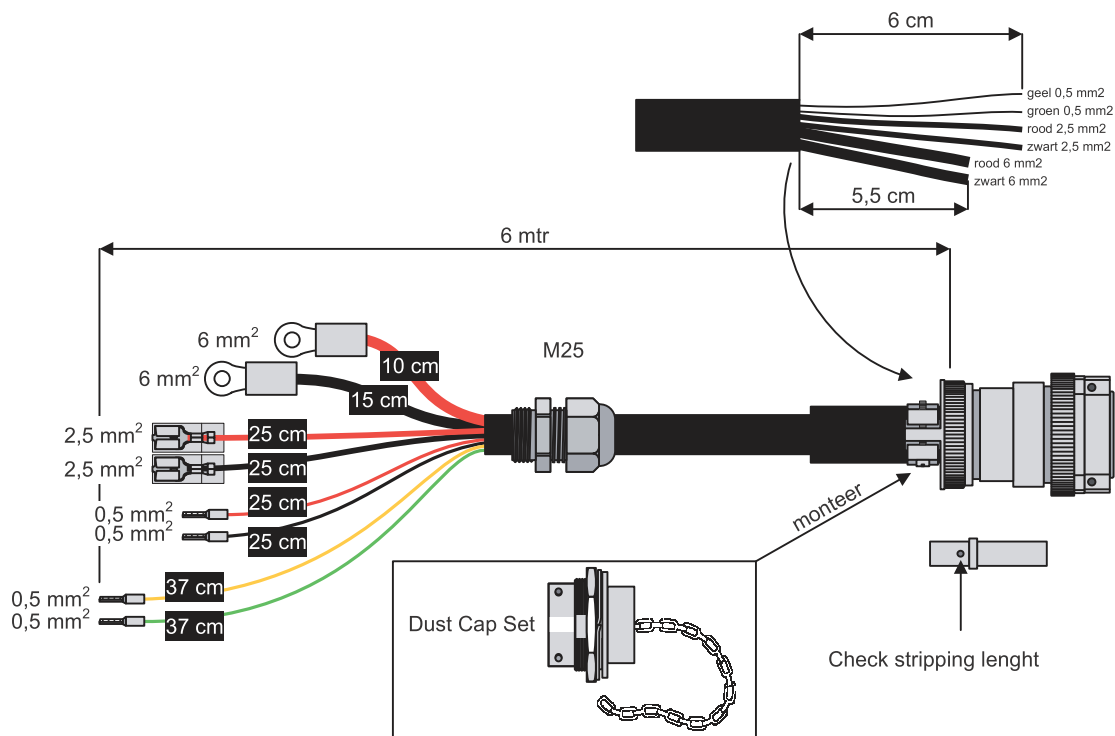

A01 - Wiring diagrams

ESD A07 - ELECTRIC CLUTCH CABLE

connector	contact	kabel	kleur	lengte	contact	function
			brown	0,8 mtr		power
			blue			

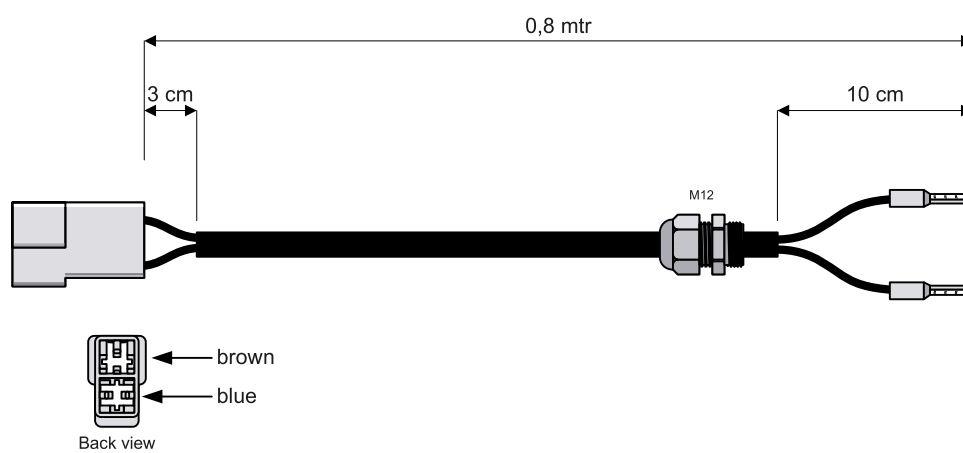



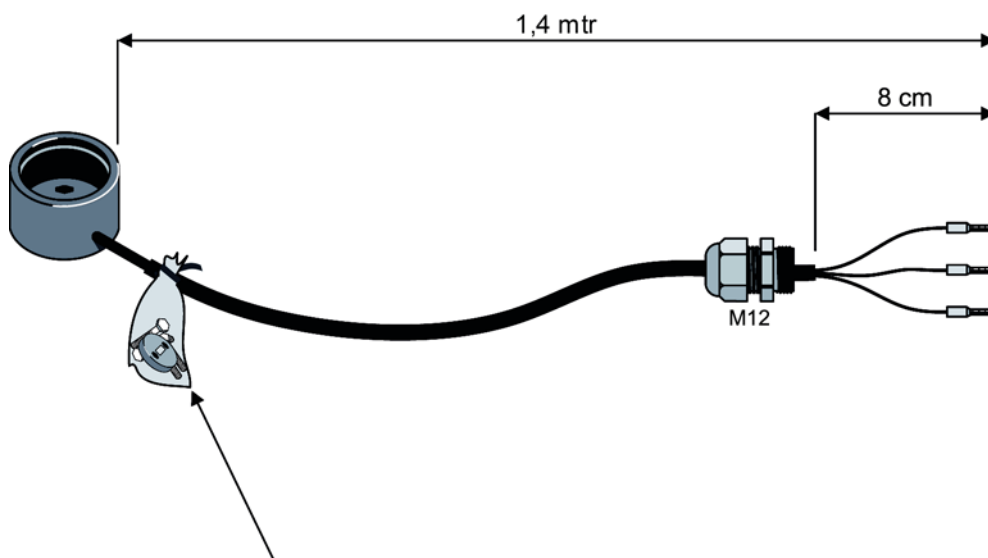

A01 - Wiring diagrams

ESD A08 - BALE DENSITY/DIAMETER CABLE

LINKS	VERBINDING			RECHTS	
sensor	kabel	kleur	lengte	contact	function
	kabel inkorten	brown	1,4 mtr		+
		black			S
		blue			-







- | | | |
|-------------------------------------------------------------------------------------|---|-------------------------------|
|  | ← | magneethouder+magnet |
|  | ← | 4x bout M5x20 - KG00494000 |
|  | ← | 4x nyloc moer M5 - KG01069700 |
|  | ← | 4x ring M5 - KG01263700 |

A01 - Wiring diagrams

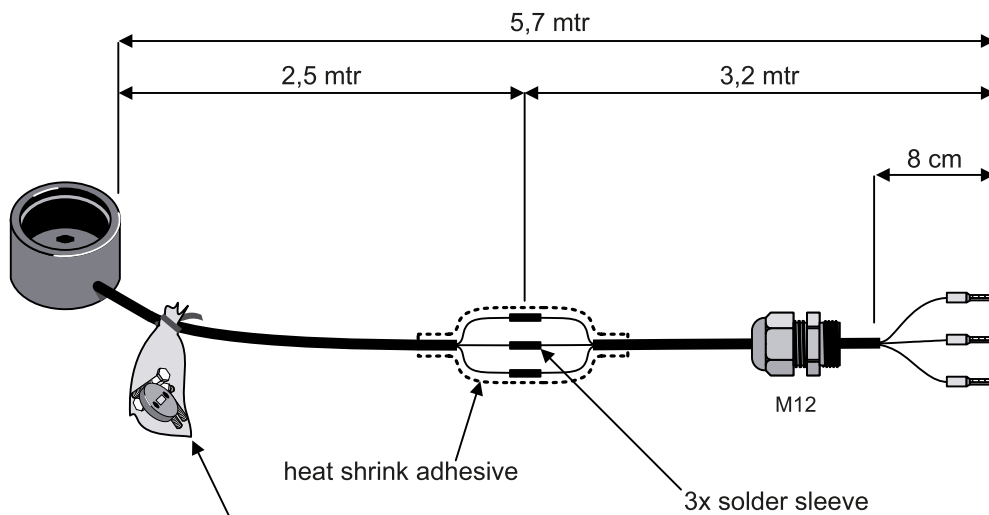
ESD A09 - DIRECTION INDICATORS CABLE

sensor	Kabel A		Kabel B		contact	function
	lengte	kleur	kleur	lengte		
2,5 mtr kabel van de sensor		brown	brown	3,2 mtr		+
		black	black			S
		blue	blue			-



-  magneethouder+magnet
-  4x bout M5x20 - KG00494000
-  4x nyloc moer M5 - KG01069700
-  4x ring M5 - KG01263700

A01 - Wiring diagrams

ESD A10 - 0° SENSOR CABLE

	kleur	lengte
power	brown	inkorten naar 1,5 mtr
S	black	
ground	blue	



A01 - Wiring diagrams

ESD A11 - 90° SENSOR CABLE

contact	kleur	lengte	sensor kabel	function
	brown			+
	black			S
	blue			-

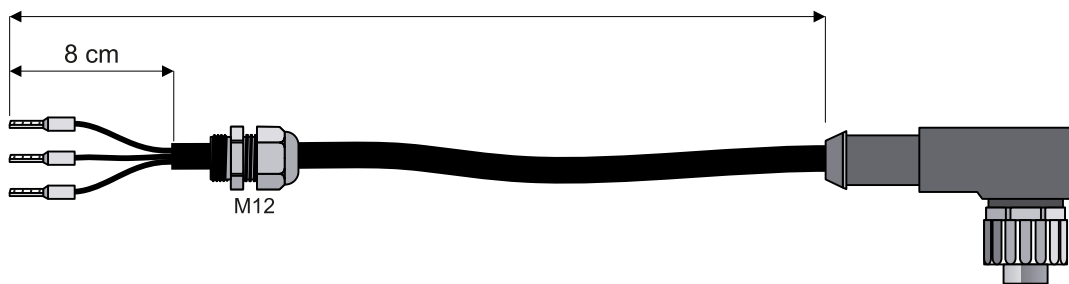

ESD A12 - SOLENOID VALVE CABLE

connector + kabel	nummer	lengte	contact	function
	1	3 mtr		
	2			

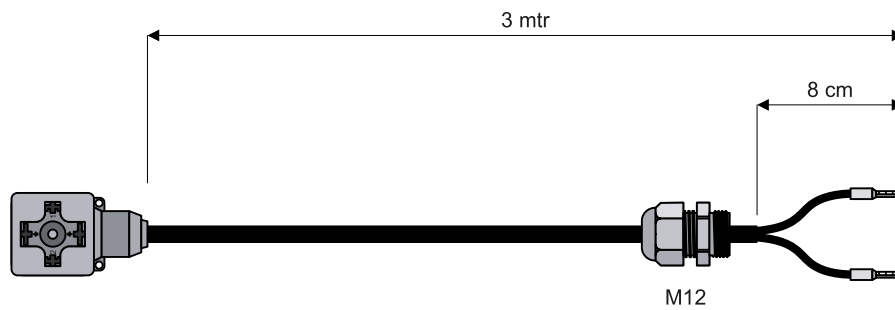

A01 - Wiring diagrams

PHOTOGRAPH

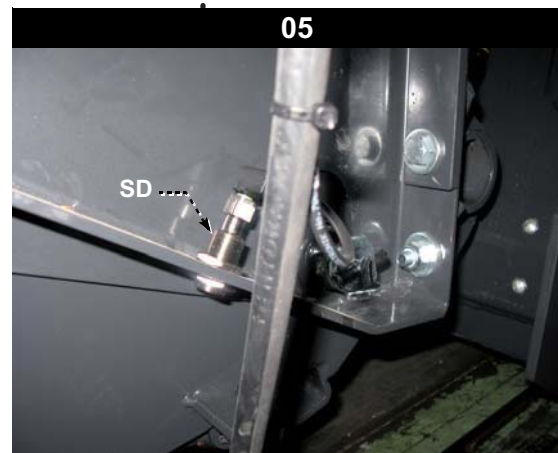
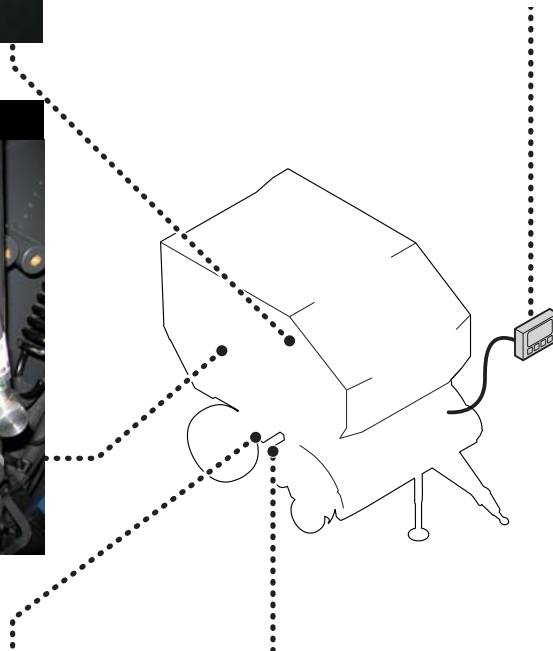
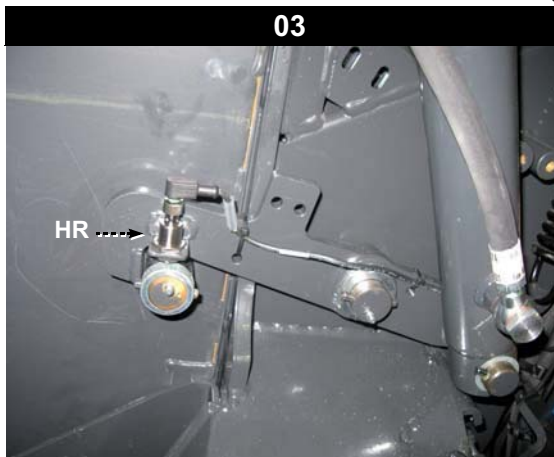
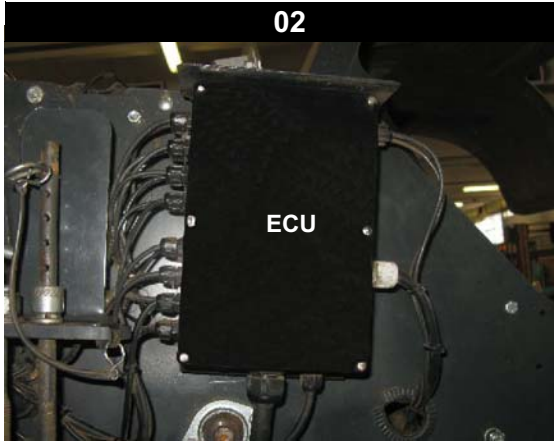

A01 - Wiring diagrams

PHOTOGRAPH

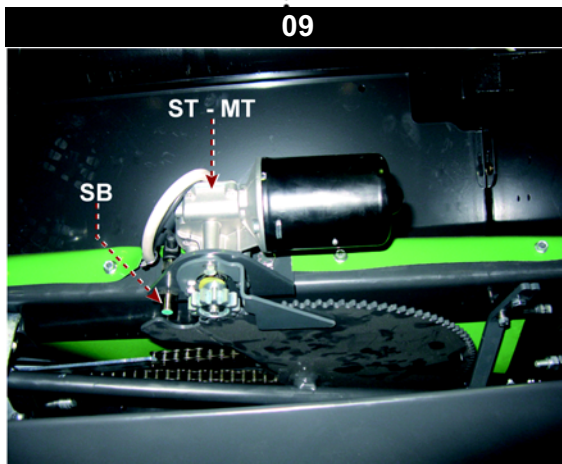
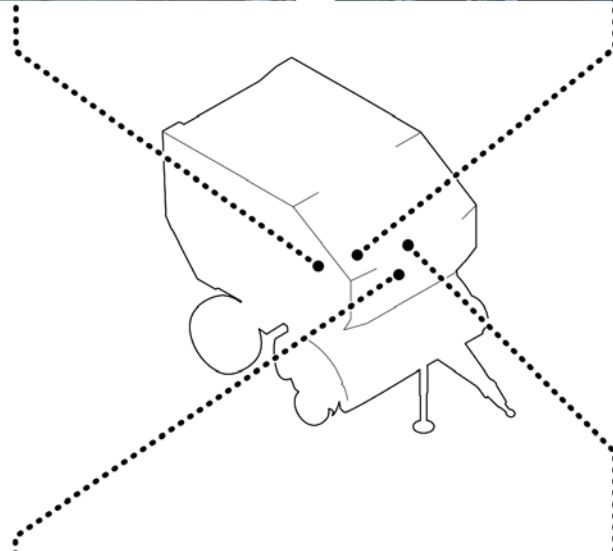
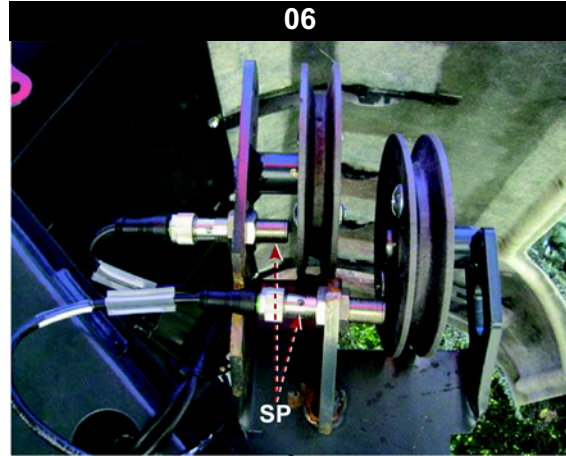
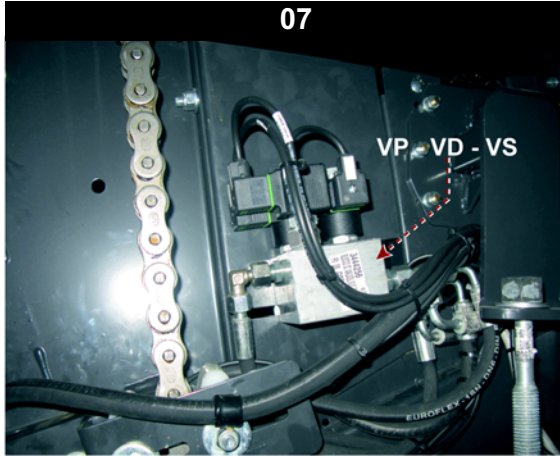

A01 - Wiring diagrams

PHOTOGRAPH

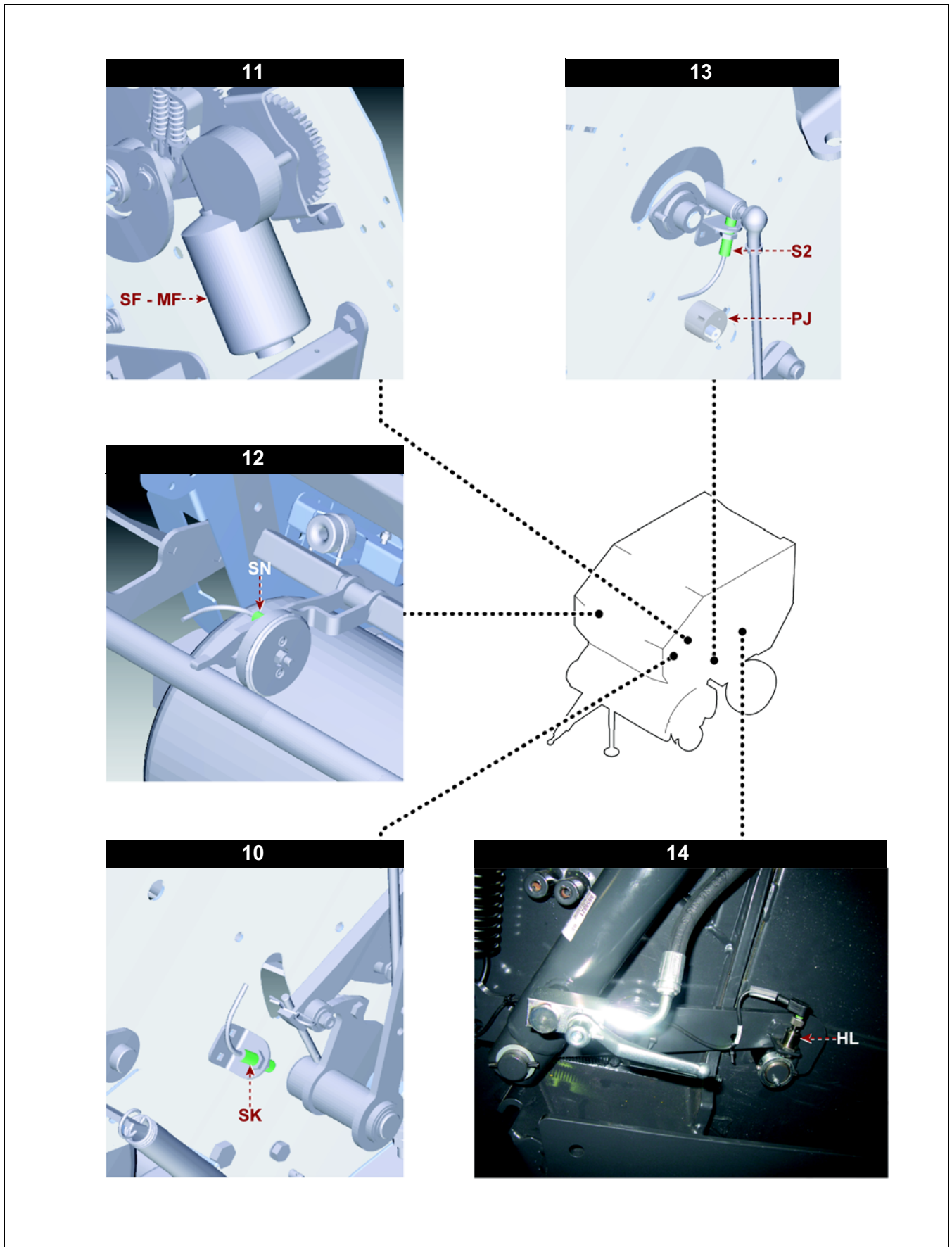

A01 - Wiring diagrams

PHOTOGRAPH

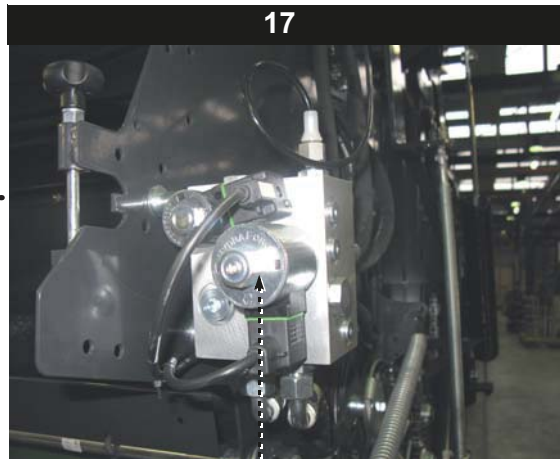
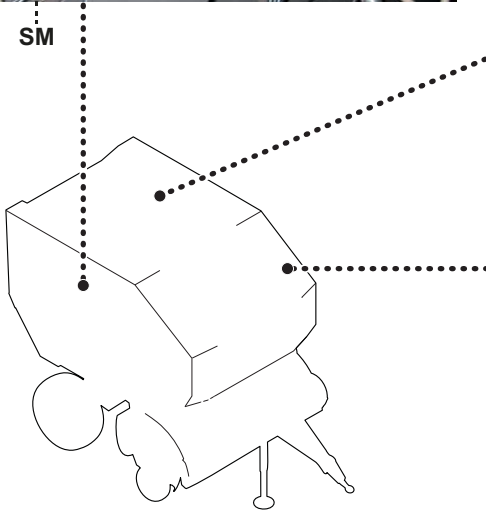
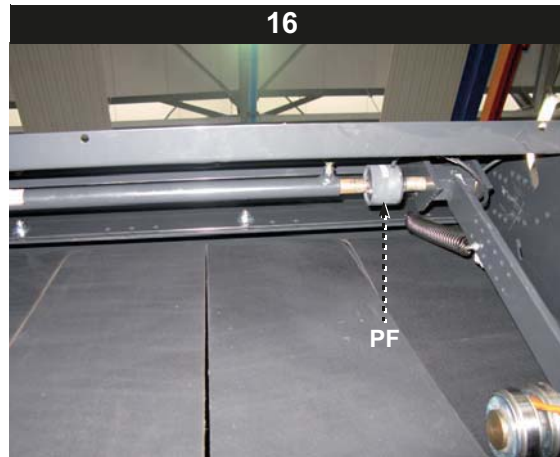

A01 - Wiring diagrams

Page intentionally left blank

A02 - Hydraulic diagrams

HSD A00 - HYDRAULIC SYSTEM

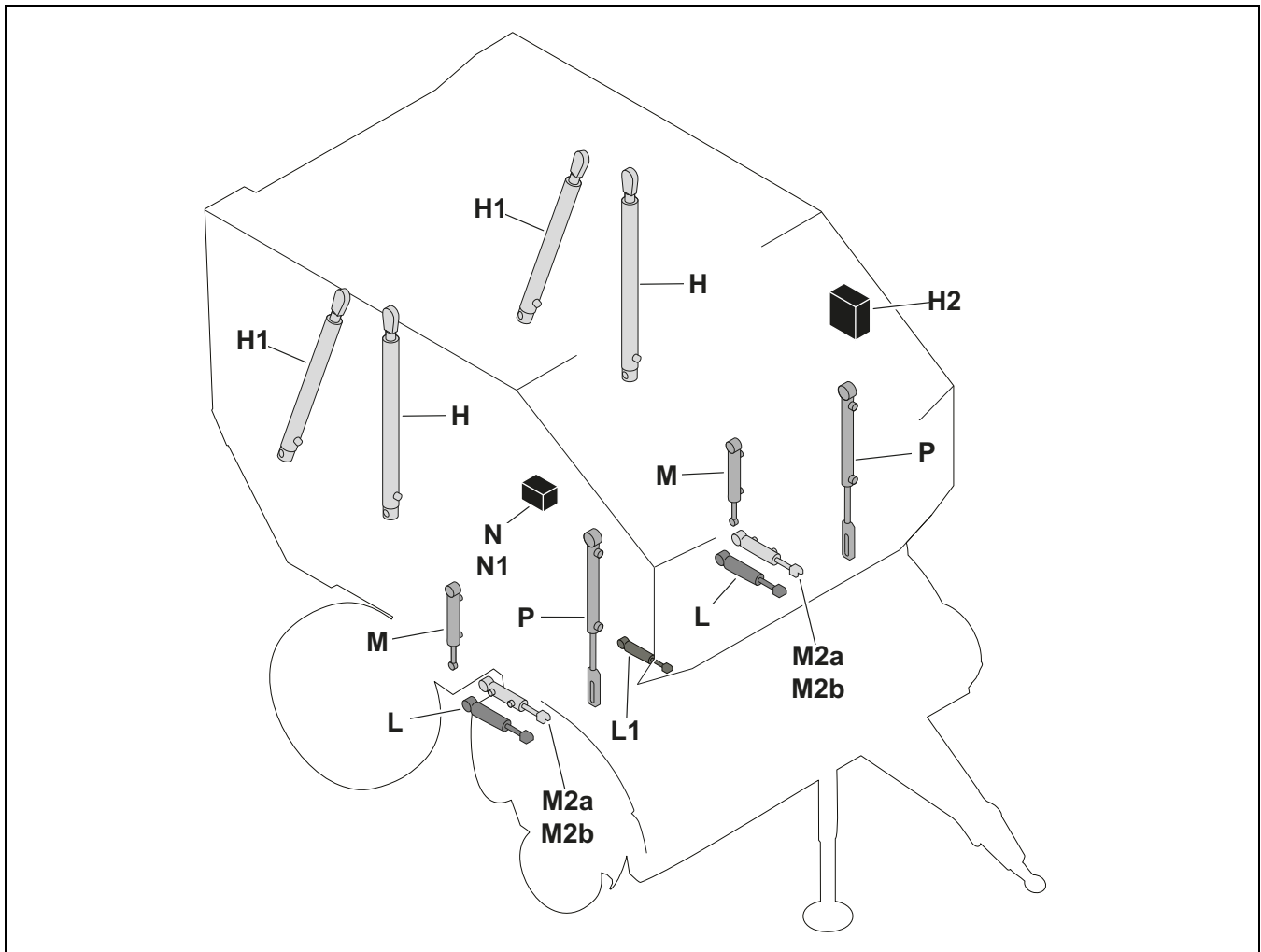

Table 2: Table of contents for hydraulic system

Ref.	Fig.	Code	Designation
L1	HSD A01		Hydraulic system diagram for machines with single action feeder fork intake and fixed pick-up unit
L+M+N	A02HSD		Hydraulic system diagram for machines with rotary feeder (with "Drop floor") and fixed pick-up unit
L+M+M2a+N1	HSD A03		Hydraulic system diagram for machines with Supercut (SC14) - Drop floor - Fixed pick-up unit
P+M+M2a+N1	HSD A03a		Hydraulic system diagram for machines with Supercut (SC14) - Drop floor - Self-leveling pick-up unit
P+M+M2b+N1	HSD A03b		Hydraulic system diagram for machines with Supercut (SC25) - Drop floor - Self-leveling pick-up unit
N	HSD A04		Rotor hydraulic block with "Drop floor"
N1	HSD A05	3444248	Supercut hydraulic block (SC14 - SC25) with "Drop floor"
H+H1+H2	HSD A06	3444256	Hydraulic system diagram for tailgate/bale density
H2	HSD A07	3944241	Hydraulic block for tailgate/bale density

A02 - Hydraulic diagrams

HSD A01 - HYDRAULIC SYSTEM DIAGRAM FOR MACHINES WITH SINGLE ACTION FEEDER FORK INTAKE AND FIXED PICK-UP UNIT

Table 3: Hydraulic system components

Ref.	Technical data	Designation	Refer to figure HSD A00
T		Tractor control valve	
2a		Single-effect control valve for tractor (pick up)	
4		Safety valve	
5		Hydraulic cylinders to operate the pick-up unit	L1

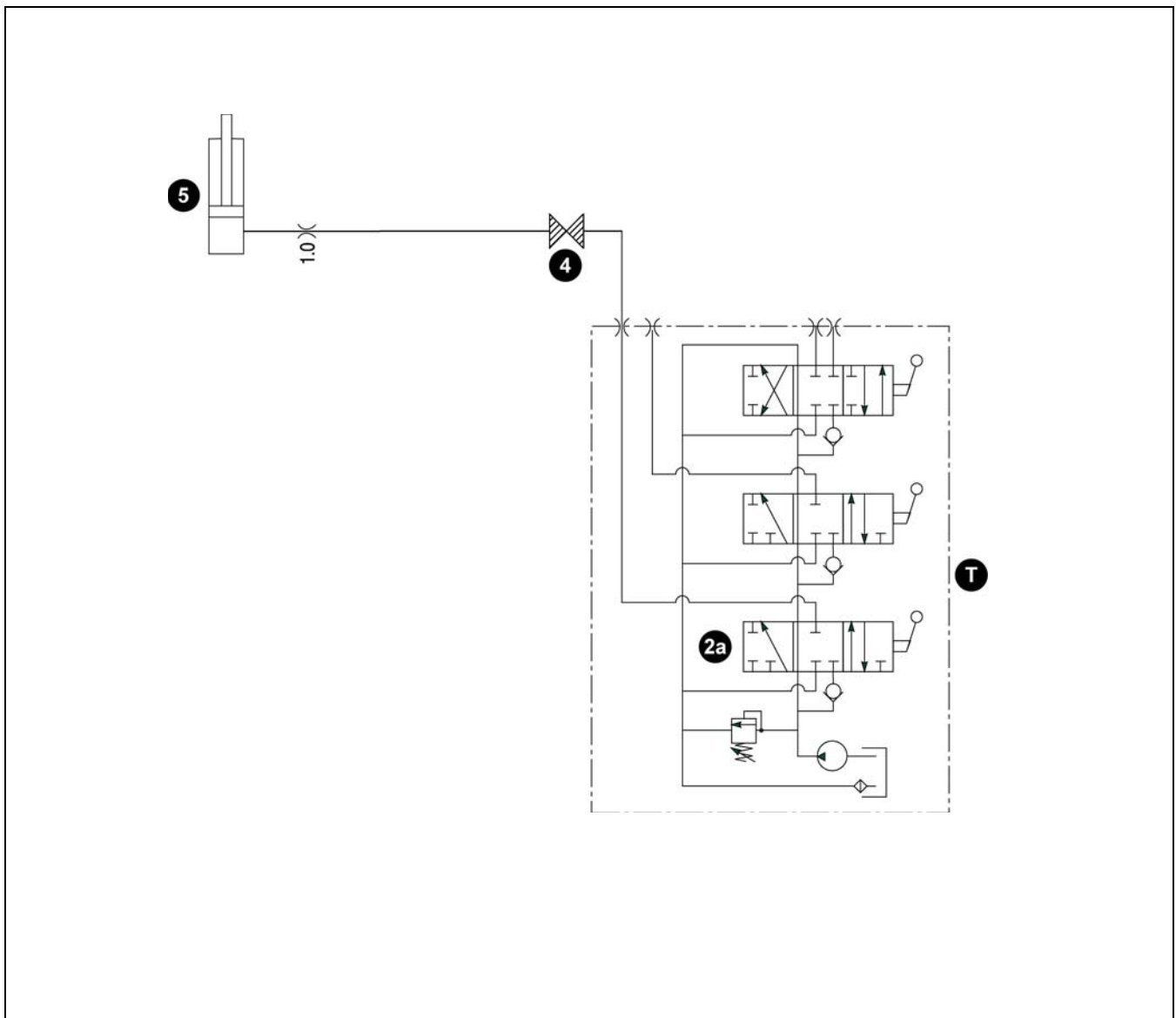

A02 - Hydraulic diagrams

HSD A02 - HYDRAULIC SYSTEM DIAGRAM FOR MACHINES WITH ROTARY FEEDER (WITH "DROP FLOOR") AND FIXED PICK-UP UNIT

Table 4: Hydraulic system components

Ref.	Technical data	Designation	Refer to figure A00
T		Tractor control valve	
2a		Single-effect control valve for tractor (pick up)	
3		Pick-up unit solenoid valve	
4		Safety valve	
5		Hydraulic cylinders to operate "Drop floor"	M
9		Hydraulic cylinders to operate the pick-up unit	L
11		Hydraulic block (3444248)	N

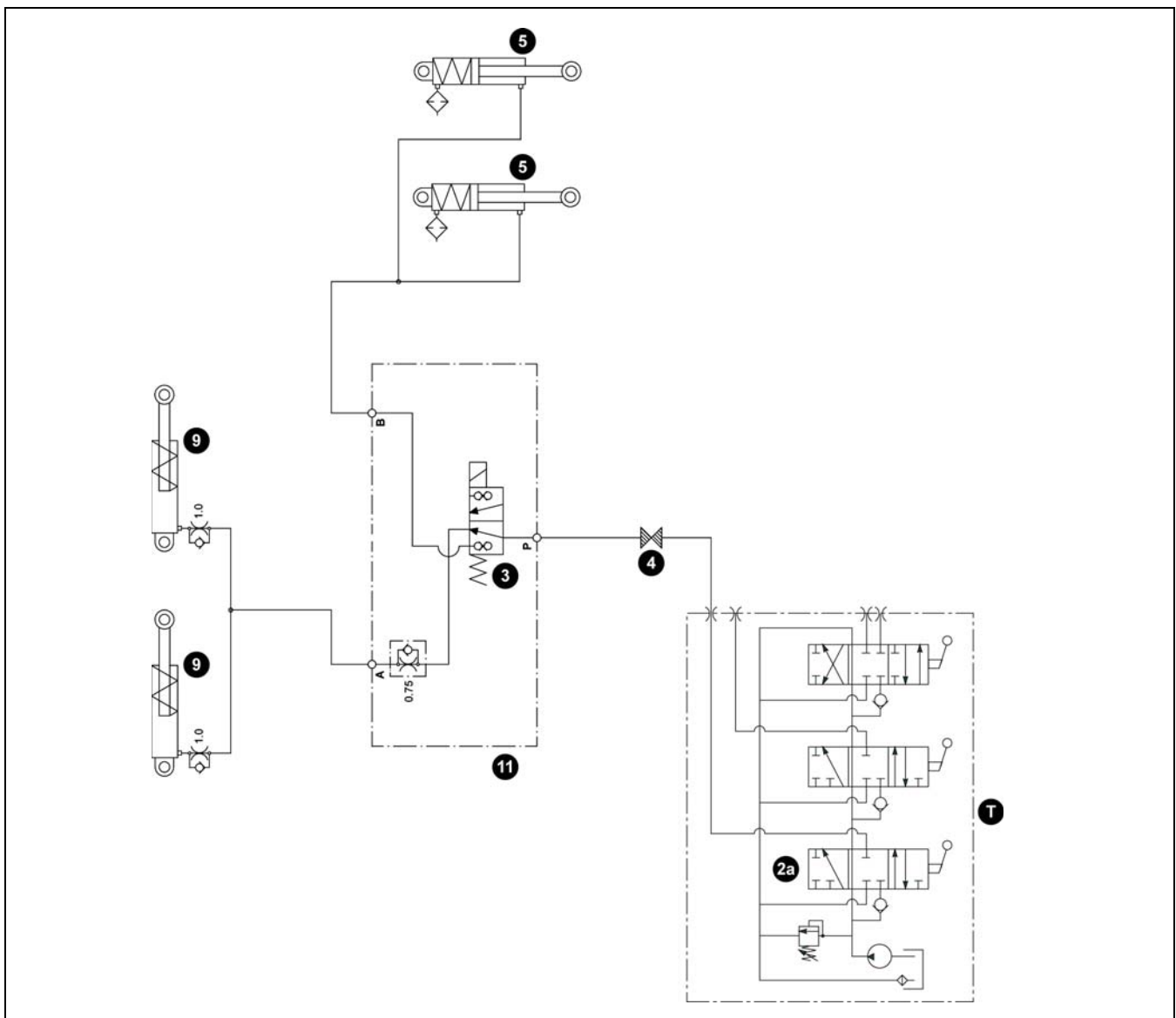

A02 - Hydraulic diagrams

HSD A03/A03a - HYDRAULIC SYSTEM DIAGRAM FOR MACHINES WITH SUPERCUT(SC14) - DROP FLOOR - FIXED OR SELF LEVELING PICK-UP UNIT

Table 5: Hydraulic system components

Ref.	Technical data	Designation	Refer to figure HSD A00
T		Tractor control valve	
2a		Single-effect control valve for tractor (pick up)	
3		Pick-up unit solenoid valve	
4		Safety valve	
5		Hydraulic cylinders to operate knives	M2a
6		Supercut solenoid valve	
7		"Drop floor" solenoid valve	
9		Hydraulic cylinders to operate the pick-up unit	L (Fixed pick-up unit) P (Self-leveling pick-up unit)
10		Hydraulic cylinders to operate "Drop floor"	M
11		Hydraulic block (3444248)	N1

A02 - Hydraulic diagrams

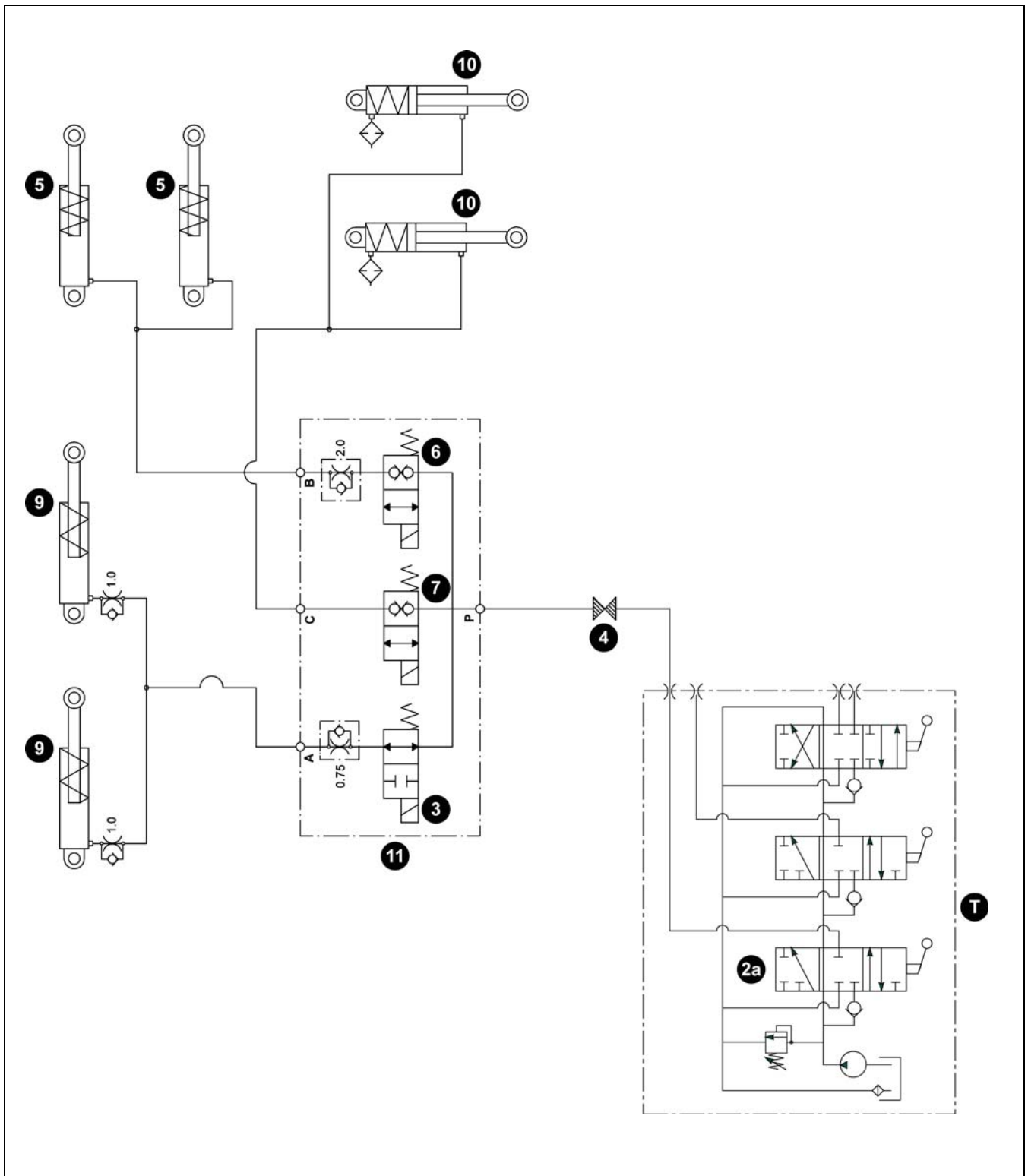

A02 - Hydraulic diagrams

HSD A03b - HYDRAULIC SYSTEM DIAGRAM FOR MACHINES WITH SUPERCUT(SC25) - DROP FLOOR - FIXED OR SELF LEVELING PICK-UP UNIT

Table 5: Hydraulic system components

Ref.	Technical data	Designation	Refer to figure HSD A00
T		Tractor control valve	
2b		Single-effect control valve for tractor (pick up)	
3		Pick-up unit solenoid valve	
4		Safety valve	
5		Hydraulic cylinders to operate knives	M2b
6		Supercut solenoid valve	
7		"Drop floor" solenoid valve	
9		Hydraulic cylinders to operate the pick-up unit	L (Fixed pick-up unit) P (Self-leveling pick-up unit)
10		Hydraulic cylinders to operate "Drop floor"	M
11		Hydraulic block (3444256)	N1

A02 - Hydraulic diagrams

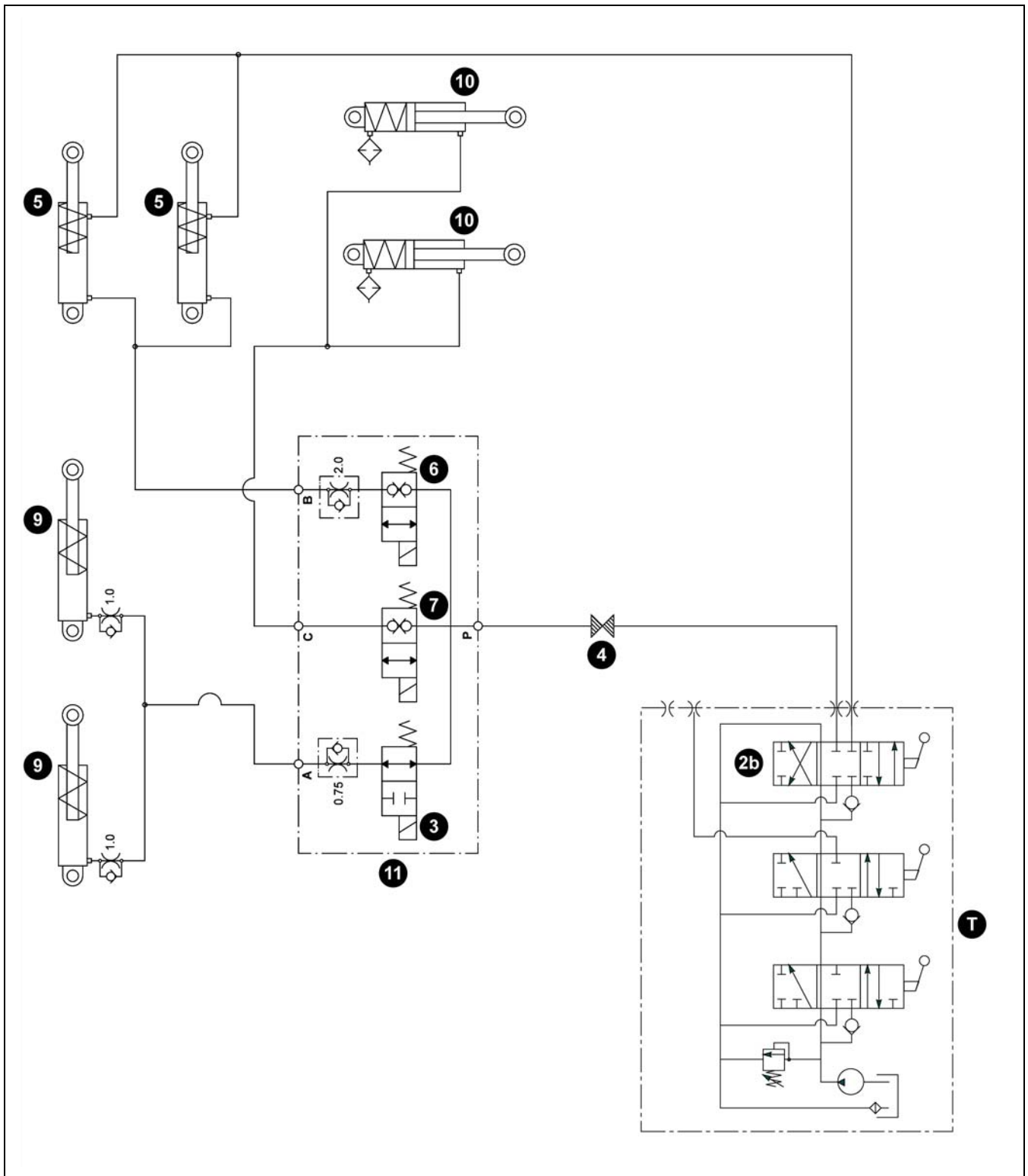

A02 - Hydraulic diagrams

HSD A04 - ROTOR HYDRAULIC BLOCK WITH "DROP FLOOR"

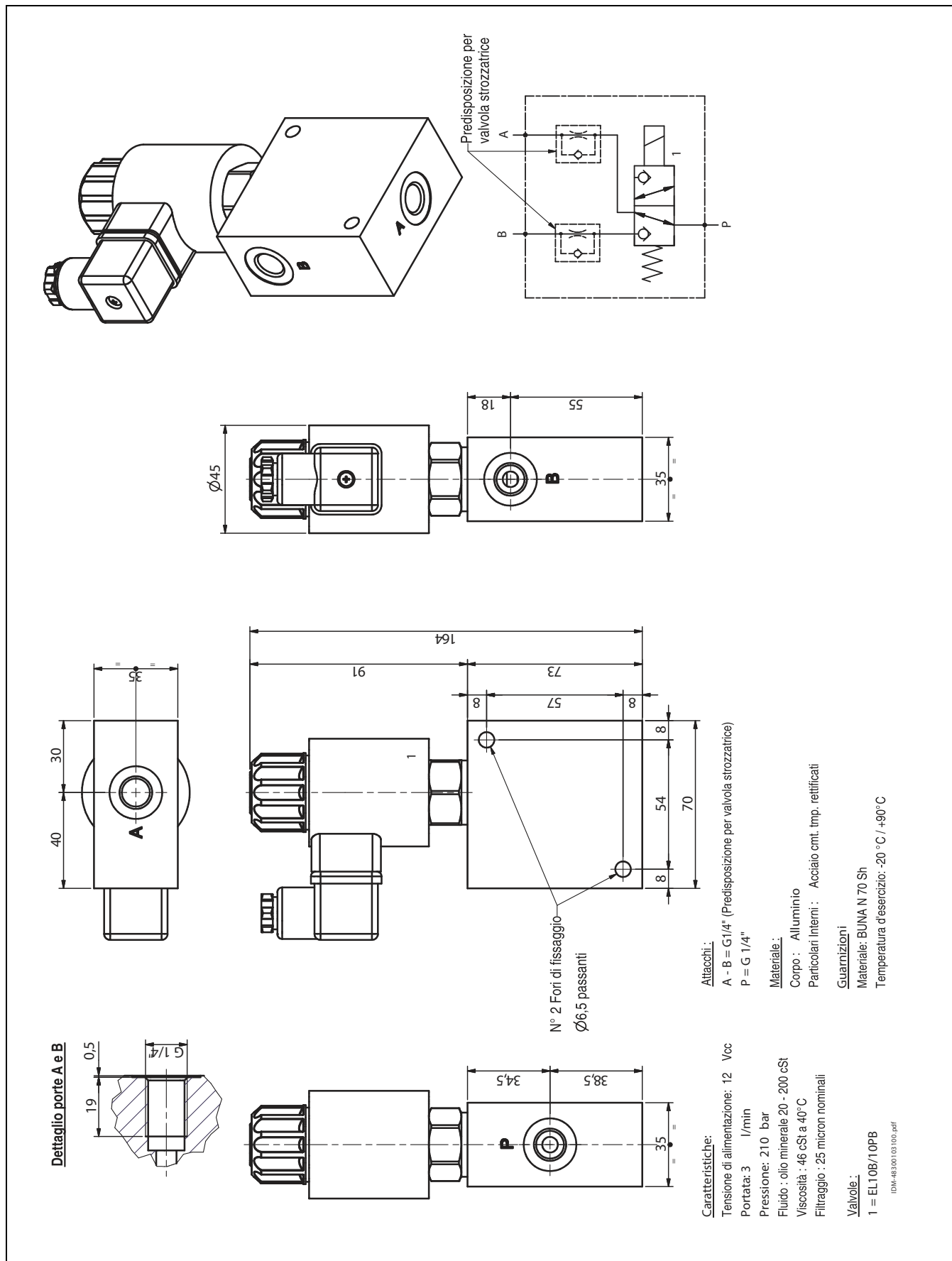

A02 - Hydraulic diagrams

HSD A05 - SUPERCUT HYDRAULIC BLOCK (SC14 - SC25)

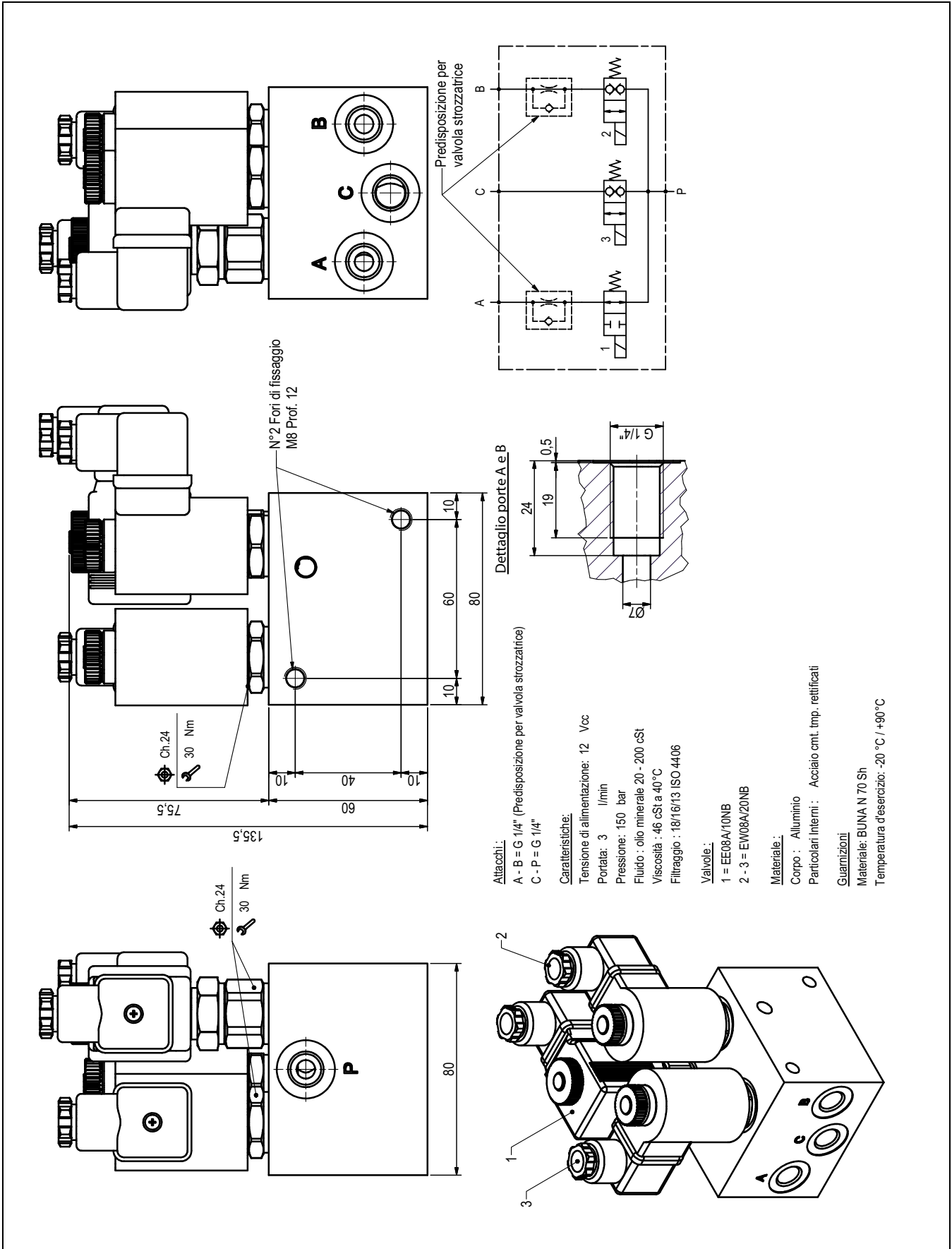

A02 - Hydraulic diagrams

HSD A06 - HYDRAULIC SYSTEM DIAGRAM FOR TAILGATE/ BALE DENSITY

Table 7: Hydraulic system components

Ref.	Technical data	Designation	Refer to figure HSD A00
1		Bale density hydraulic cylinder (right)	H1
2		Bale density hydraulic cylinder (left)	H1
3		Check valve	
4		Tailgate hydraulic cylinder (right)	H
5		Tailgate hydraulic cylinder (left)	H
6		Safety valve	
7	2.0	One-way throttle	
8		Pressure gauge	
10		Hydraulic block for tailgate/bale density	H2
11		Bypass valve	
12	2.5	One-way throttle	
14		Filter	

A02 - Hydraulic diagrams

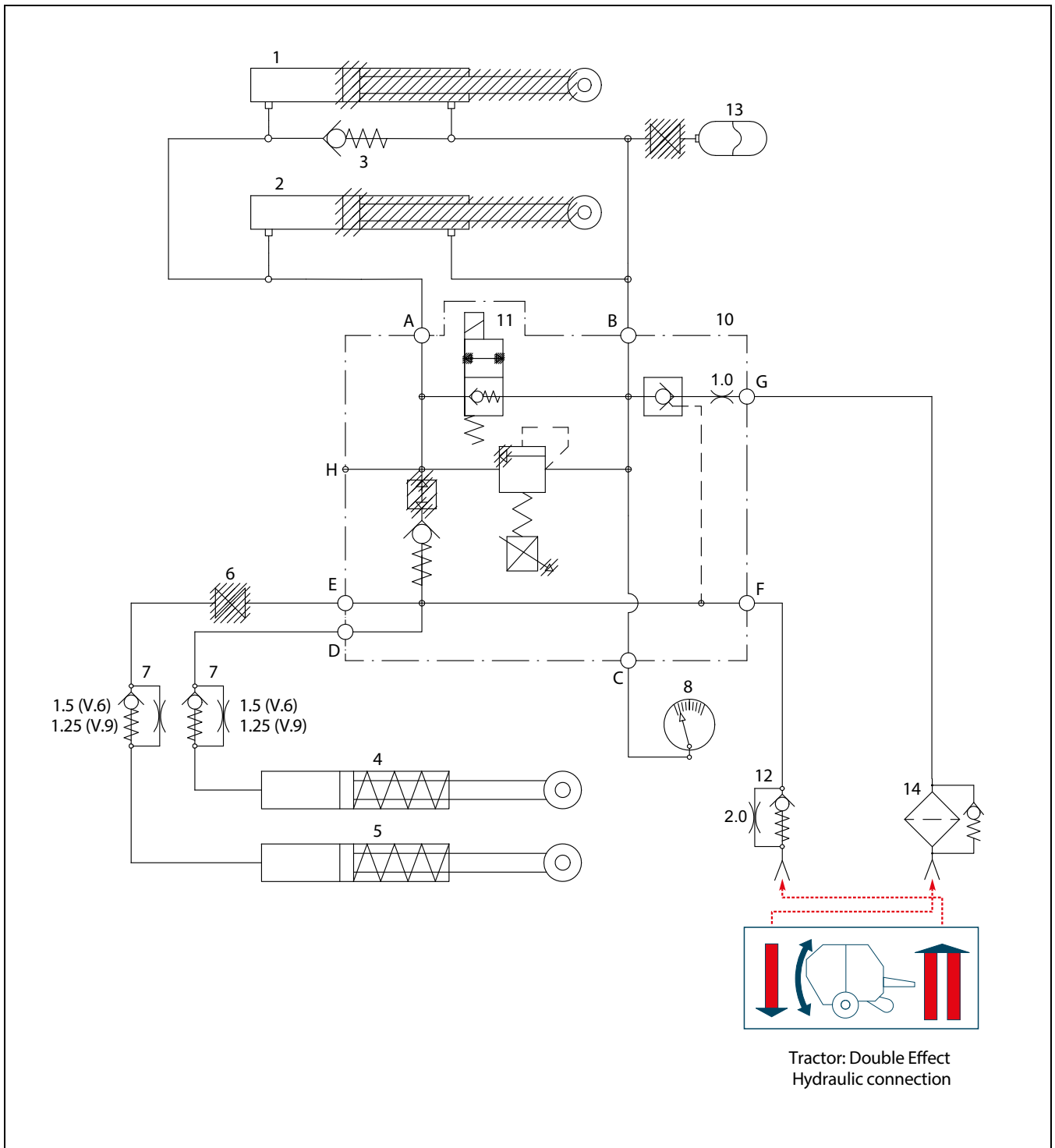

A02 - Hydraulic diagrams

HSD A07 - HYDRAULIC CONTROL VALVE FOR TAILGATE/BALE DENSITY

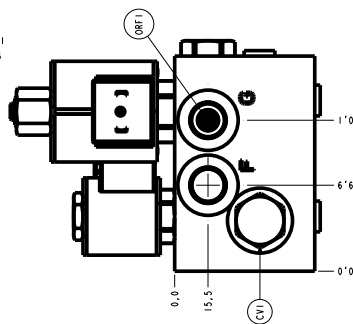
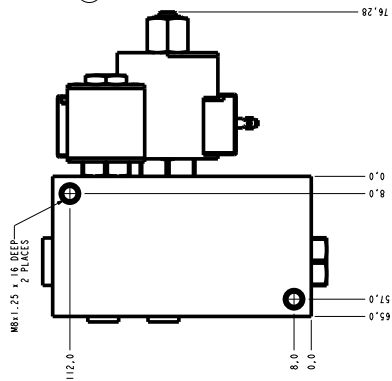
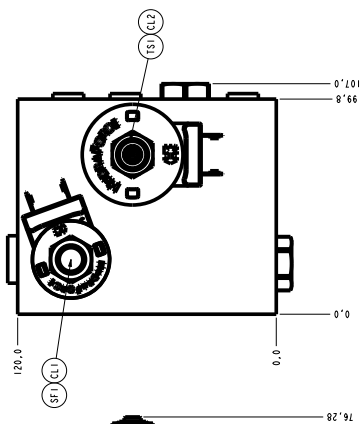
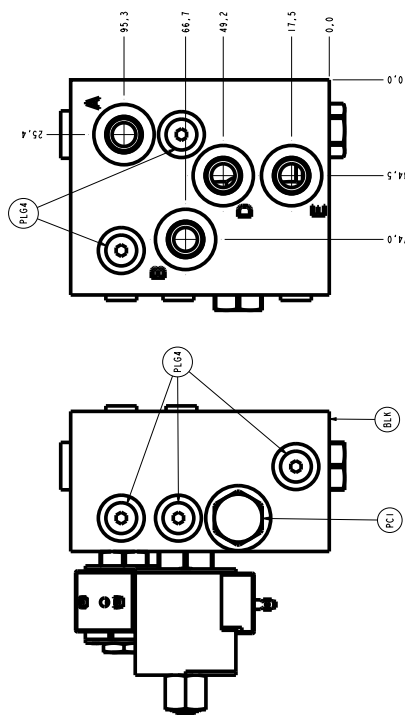
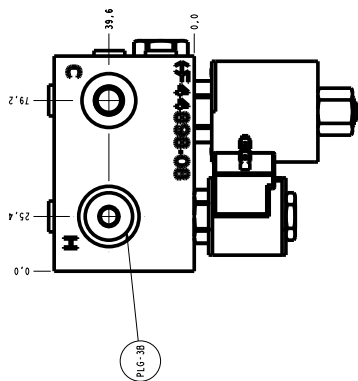
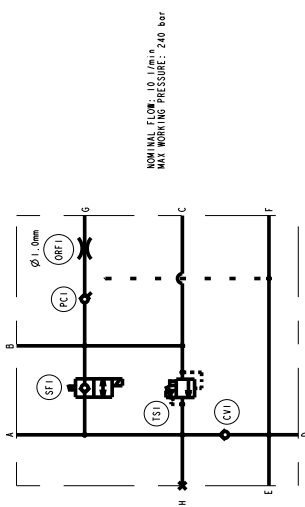

PORTING:
PORT C - 61/4" BSP
ALL OTHER PORTS - G3/8" BSP
MATERIAL:
ALUMINIUM

THE SERIES E SOLUTIONS ARE USED IN THIS APPLICATION ARE WATERPROOF AND THERMAL SHOCK RESISTANT EXCEEDING PARTS AS WELL AS 1.1871 OR 1.1876 (EN10059) - DEPENDING ON THE INFORMATION ON CHEMICAL AND OPERATING SHOCK RESISTANCE.

PARTS LIST

ITEM	QTY	MODEL NUMBER / DESC.
PLG-3B	1	1416002-3B 21/8 BSP PLUG
SF1	1	1416002-3B 21/8 BSP
CV1	1	1416002-3B 21/8 BSP
SF1	1	15138-20A 0.4 N-10
PC1	1	15138-22 0.4 N-10
CL1	1	PC08-30 0.4 N-10
CL2	1	COIL 4303882
NOT SHOWN	1	COIL 4303882
EXP	5	EXPANDED PLUG 6108070
PLG4	5	EXPANDED PLUG 6108070
CV1	1	1416002-3B 21/8 BSP
BLK	1	BLOCK 1381800

A			
Accessories available upon request	49		
Adjust the centralized lubrication system	160		
Adjusting the belts' alignment	166		
Adjusting the braking device	213		
Adjusting the chains on the twine guide arms	229		
Adjusting the cleaning rollers	163		
Adjusting the compensation springs	216		
Adjusting the cut reset device	214		
Adjusting the density in the event of an electronic control system malfunction	119		
Adjusting the feed roller's position	189		
Adjusting the height of the baffle plate	188		
Adjusting the height of the pick-up unit	187		
Adjusting the pick-up unit's suspension	186		
Adjusting the pick-up unit's transmission chain	189		
Adjusting the RESET/START position sensor	217		
Adjusting the shockproof springs	215		
Adjusting the tilt of the baffle plate	188		
Adjusting the tilting baffle plate	188		
Adjusting the transmission chains	159		
Adjusting the twine tightening clamps	228		
Advanced Settings menu	133		
Alarms list	136		
Annexed documentation	11		
B			
Bale density setting	114		
Bale diameter setting	113		
Bale formation in manual mode	123		
Bale growth bar	120		
Bale unloading	91		
Belts misaligned towards the left side	167		
Belts misaligned towards the right side	166		
Binding	121		
C			
Changing the reducer oil	158		
Checking the belts' alignment	165		
Checking the safety screws' tightening torque	158		
Cleaning the belt guiding rollers	169		
Cleaning the machine	150		
Commands with net binding	106		
Commands with twine binding	107		
Configure Buttons menu	132		
Connecting the electrical system	79		
Connecting the electronic control system	80		
Connecting the hydraulic system	78		
Connecting the PTO drive shaft	78		
Connecting the towing hitch to the machine's eyelet	77		
Counters Menu	131		
		Coupling the machine to the tractor	77
		Cutting device activation and deactivation	218
D			
		Danger zones	35
		Danger, warning and caution labels	27
		Decal descriptions	27
		Decommissioning the machine	85
		Description of controls	95
		Description of the "control bar" icons	99
E			
		Electrical devices	192, 196, 202, 210, 220
		Electronic and electrical devices	51
		Electronic bale density setting	117
		Electronic control panel	45
		Electronic setting with "0 bar" / by-pass valve	116
		Equipment	48
		Equipment functionality troubleshooting	134
		Extraordinary maintenance	150
F			
		Feeding the machine	90
		Field operation	120
G			
		General description	43, 183, 191, 195, 201, 209, 219
		General description of the equipment	96
		General precautions	14
		General safety regulations	14
		Glossary and terminology	11
H			
		Handling and loading instructions	67
		Handling the pick-up unit	184
		Hydraulic devices	50, 184, 192, 196, 202
		Hydraulic safety	25
I			
		Icon descriptions	99
		Improper use	39
		Information for the employer	20
		Inserting twine	221
		Instructions and advice for use	89
		Introduction to the manual	7

Index

K	
Knives' replacement	198, 205
L	
Left/Right driving indicator	120
List of screen icons	102
Loading and unloading	68
Loading the machine using a hook-type lifting device	70
Loading the machine using the tractor	68
Locations of the safety decals	33
Lock screen	106
Lubricant table	145
Lubrication of shaft with brake (optional)	149
Lubrication points diagram	147
M	
Machine "with bale kicker"	92
Machine "without bale kicker"	91
Machine disposal	86
Machine malfunctions	152
Machine-tractor combination	71
Main components	44
Manual binding cycle start	123
Manual equipment for vise ("MATO" type junctions)	173
Manually setting the bale density	115
Manufacturer and machine identification	10
Modifying the height of the drawbar	72
N	
Net binder	98
Net binding	108
Net binding unit malfunctions	153
O	
Opening the guards	157
Operating cycle	45
Operating logic diagram	96
P	
Packing and unpacking	67
Parameter programming	105
Permissible slopes	35
Personal protective equipment	22
Pick-up unit malfunctions	153
Positioning of knives	204
Preliminary checks and inspections	71
Preliminary maintenance operations	21
Preliminary work inspections	89
Preparing work	
binding settings	111
Problems - Causes - Solutions	151
Procedure to request technical assistance	11
Product defects	151
Purpose of this manual	13
Putting the machine back into service	84
R	
Recommendations for adjustments	139
Recommendations for maintenance	139
Recommendations for parts replacements	140
Recommendations for use and operation	86
Reference operators	21
Reference standards	8
Regional settings	133
Replacing the baling chamber's belts	171
Replacing the blade	230
Replacing the tires	179
Residual risks	39
Re-stocking the net reel	211
Re-stocking the twine reels	225
Road travel	92
S	
Safety devices on board the machine	37
Safety regulations for loading and unloading	15
Safety regulations for maintenance and adjustments	24
Safety regulations for road travel	16
Safety regulations for use and operation	16
Safety rules for the protection of the environment	26
Scheduled maintenance intervals chart	140
Scrapping the machine	86
Setting the height of the drawbar	72
Setting the length of the PTO shaft	74
Settings with "twine" binding	128, 130
Settings with net binding	127, 130
Sharpening of knives	199, 207
Signaling devices	36
Storing the machine at the end of season	83
Symbols used	9
T	
Technical data BV 5160 R	53
Technical data BV 5160 SC	56
Technical data BV 5200 R	59
Technical data BV 5200 SC	62
Technical data of the electronic control panel	65
Tightening torque table	146
Topping up the centralized lubrication system's oil	162
Troubleshooting table	151
Twine binding	97, 109

Twine binding unit malfunctions 154

U

Unblocking the feeding unit 193, 197, 203
Unblocking the pick-up unit 185
Uncoupling the machine from the tractor 81
Using the drop floor's release device 125
Using the hydraulic functions 124
Using the Pick-up 124
Using the Supercut knives 124

W

Warranty conditions 11
Windrow size and type 89
Work screen 108
Working at night 38
Working settings Menu 126