



- U.S.A. : **Kubota Tractor Corporation**
1000 Kubota Drive, Grapevine, Texas 76051, U.S.A.
Telephone : (1)-817-756-1171
- Canada : **Kubota Canada Ltd.**
1155 Kubota Drive, Pickering, Ontario L1X 0H4, Canada
Telephone : (1)-905-294-6535
- France : **Kubota Europe S.A.S.**
19-25, Rue Jules Verceyruisse, Z.I., BP88 95101 Argenteuil Cedex, France
Telephone : (33)-1-3426-3434
- Italy : **KUBOTA EUROPE S.A.S Italy Branch**
Via Grandi, 29 20068 Peschiera Borrome (MI) Italy
Telephone : (39)02-51650377
- Germany : **Kubota Baumaschinen GmbH**
Steinhauser Straße 100, 66482 Zweibrücken Rheinlandpfalz, Germany
Telephone : (49)-6332-4870
- U.K. : **KUBOTA (U.K.) LTD.**
Dormer Road, Thame, Oxfordshire, OX9 3UN, U.K.
Telephone : (44)1844-214500
- Spain : **Kubota España S.A.**
Calle Fernando Alonso número 15, Leganés, 28914 (Madrid), Spain
Telephone : (34)-91-508-6442
- Turkey : **KUBOTA TURKEY MAKINE TIC.LTD.ŞTI.**
Cumhuriyet Mah. Yahya Kaptan Cad. No:3 Cayirova / Kocaeli/Turkey 41420
Telephone : (90)262-658-9045
- Australia : **KUBOTA AUSTRALIA PTY LTD.**
25-29 Permas Way, Truganina, VIC 3029, Australia
Telephone : (61)-3-9394-4400
- Malaysia : **KUBOTA MALAYSIA SDN. BHD.**
Lot 766, Jalan Subang 4, off Persiaran Subang Sungai Penaga Industrial Park,
47500 Subang Jaya
Telephone : (60)-3-7890-3533
- Philippines: **KUBOTA PHILIPPINES, INC.**
232 Quirino Highway, Baesa, Quezon City 1106, Philippines
Telephone : (63)2-422-3500
- Taiwan : **SHIN TAIWAN AGRICULTURAL MACHINERY CO., LTD.**
16, Fengping 2nd Rd, Taliiao Shiang Kaohsiung 83107, Taiwan R.O.C.
Telephone : (886)7-702-2333
- Indonesia : **PT KUBOTA MACHINERY INDONESIA**
Tower A at EightyEight@Kasablanka Lantai 16
Jalan Raya Casablanca Kav. 88, Jakarta 12870 Indonesia
Telephone : (62)-21-29568-720
- Thailand : **SIAM KUBOTA CORPORATION CO., LTD.**
101/19-24 Moo 20, Navanakorn Industrial Estate, Tambon Khlongnueng, Amphur Khlongluang,
Pathumthani 12120, THAILAND
Telephone : (66)2-909-0300
- Korea : **KUBOTA KOREA CO., LTD.**
41-27, Jayumuyeok-gil, Baeksan-myeon, Gimje-si, Jeollabuk-do, Korea
Telephone : (82)-63-544-5822
- India : **KUBOTA AGRICULTURAL MACHINERY INDIA PVT. LTD.**
B 500 A & C, Indospace Industrial Park, 104 Polivakkam Village,
Sriperumbadur-Thiruvallur Main Road, Thiruvallur District-602 002.
Telephone : (91)44-4019-2000
- Vietnam : **KUBOTA VIETNAM CO., LTD.**
Lot B-3A2-CN, My Phuoc 3 Industrial Park, Thoi Hoa Ward, Ben Cat Town, Binh Duong Province, Vietnam
Telephone : (84)-274-3577-507

BB . B . 3 - 3 . - . AK

English (U.S.A.)
Code No. K7821-7122-4

OPERATOR'S MANUAL

KUBOTA RTV-XG850 UTILITY VEHICLE SIDEKICK



1TNBR00001A01

This OHRV is equipped with exhaust and evaporative emission controls. The removal or modification of evaporative or exhaust emission-related parts on this OHRV is illegal. Violators may be subject to civil and/or criminal penalties as provided under California and federal law.

R
T
V
-
X
G
8
5
0

READ AND SAVE THIS MANUAL



ABBREVIATION LIST

Abbreviations	Definitions
2WD	Two Wheel Drive
4WD	Four Wheel Drive
API	American Petroleum Institute
ASTM	American Society for Testing and Materials, USA
EFI	Electronic Fuel Injection
Km/h	Kilometers Per Hour
MPH	Miles Per Hour
m/s	Meters Per Second
PTO	Power Take Off
RH/LH	Right-hand and left-hand sides are determined by facing in the direction of forward travel
ROPS	Roll-Over Protective Structures
rpm	Revolutions Per Minute
r/s	Revolutions Per Second
SAE	Society of Automotive Engineers, USA
CVT	Continuously Variable Transmission
EPS	Electric Power Steering

Intended use

This vehicle is designed solely for multipurpose off-highway utility vehicle and intended for utility use,also having the characteristics as mentioned in ANSI/OPEI B71.9-2016 Multipurpose Off-Highway Utility Vehicles.

California Proposition 65

 **WARNING** : Operating, servicing and maintaining off road equipment or off road vehicles can expose you to inhalation of or contact with chemicals including engine exhaust, carbon monoxide, phthalates, and lead which are known to the state of California to cause cancer and birth defects or other reproductive harm. To minimize exposure:

- Avoid breathing exhaust.
- Always start and operate the engine in a well ventilated area.
- If in an enclosed area, vent the exhaust to the outside.
- Do not modify or tamper with the exhaust system.
- Do not idle the engine except as necessary.
- Service your equipment or vehicle in a well ventilated area.
- Wear gloves or wash your hands frequently when servicing your equipment or vehicle.

For more information go to: WWW.P65warnings.ca.gov

IMPORTANT

The engine in this machine is equipped by the manufacture with a standard spark arrester.
It is a violation of California Public Resource Code Section 4442 to use or operate this engine on or near any forest-covered, brush-covered land, or grass- covered land unless the exhaust system is equipped with a working spark arrester meeting state laws. Other states or federal areas may have similar laws.

Canadian Electromagnetic Compatibility (EMC):
This machine complies with Industry Canada ICES-002.

UNIVERSAL SYMBOLS

As a guide to the operation of your vehicle, various universal symbols have been utilized on the instruments and controls. The symbols are shown below with an indication of their meaning.



Safety Alert Symbol



Seat Belt (3 point type)



Fuel - Level / Gasoline Fuel



Hourmeter / ELAPSED OPERATING HOURS



Engine Coolant - Temperature



Brake Fluid



Parking Brake



Battery Charging Condition



Engine Oil - Pressure



Turn Signal / Hazard



Engine - Rotational Speed



Engine - STOP



Engine - RUN



Starter Control



Engine Warning



EPS Warning



Differential Lock



Differential Lock HOLD



Steering Wheel - Tilt Control



Hazard Warning Lights



Headlight - LOW beam



Headlight - HIGH beam



Master System Warning



Audible Warning Device



4-Wheel Drive - ON



LOCK



UNLOCK

FOREWORD

You are now the proud owner of a KUBOTA Vehicle. This vehicle is a product of KUBOTA quality engineering and manufacturing. It is made of excellent materials and under a rigid quality control system. It will give you long, satisfactory service. To obtain the best use of your vehicle, please read this manual carefully. It will help you become familiar with the operation of the vehicle and contains many helpful hints about vehicle maintenance. This manual contains instructions for minor maintenance, but information about major repairs is outlined in the KUBOTA Workshop Manual and should be performed only by a KUBOTA Dealer Technician. It is KUBOTA's policy to utilize as quickly as possible every advance in our research. The immediate use of new techniques in the manufacture of products may cause some small parts of this manual to become outdated. KUBOTA distributors and dealers will have the most up-to-date information. Please do not hesitate to consult with them.



SAFETY FIRST

This symbol, the industry's safety alert symbol, is used throughout this manual and on labels on the machine itself to warn of the possibility of personal injury. Read these instructions carefully. It is essential that you read the instructions and safety regulations before you attempt to assemble or use this unit.



DANGER: Indicates an imminently hazardous situation which, if not avoided, will result in death or serious injury.



WARNING: Indicates a potentially hazardous situation which, if not avoided, could result in death or serious injury.



CAUTION: Indicates a potentially hazardous situation which, if not avoided, could result in minor or moderate injury.

IMPORTANT: Indicates that equipment or property damage could result if instructions are not followed.

NOTE: Gives helpful information.

CONTENTS

SAFE OPERATION	5
SERVICING OF VEHICLE	17
WARRANTY.....	17
SCRAPPING THE VEHICLE	17
REPORTING SAFETY CONCERNS IN CANADA.....	18
SPECIFICATIONS	19
SPECIFICATION TABLE.....	19
TRAVELING SPEEDS	20
VEHICLE LIMITATIONS	21
INSTRUMENT PANEL AND CONTROLS	22
LOCATION OF PARTS	22
INSTRUMENT PANEL	25
PRE-OPERATION CHECK	26
DAILY CHECK	26
OPERATING THE ENGINE	27
STARTING THE ENGINE	27
1. Cold weather starting.....	28
STOPPING THE ENGINE.....	29
WARMING UP THE ENGINE	29
JUMP STARTING	29
STARTING WHEN THE ENGINE IS FLOODED	30
OPERATING THE VEHICLE	33
OPERATING NEW VEHICLE	33
1. Do not operate the vehicle at full speed for the first 50 hours	33
2. Changing lubricating oil for new vehicles	33
STARTING THE VEHICLE.....	33
1. Locking and unlocking the door.....	33
2. Seat belt	34
3. Tilt steering wheel (if equipped).....	34
4. Head light switch	34
5. Hazard light switch (if equipped)	35
6. Turn signal light switch (if equipped)	35
7. Horn button.....	35
8. Brake pedal	36
9. Range gear shift lever	36
10. 4WD lever.....	37
11. Parking brake lever.....	37
12. Speed control pedal.....	37
13. Electric power steering	37
STOPPING THE VEHICLE	38
CHECK DURING DRIVING	38
1. Easy Checker™	38
2. Fuel gauge.....	39
3. Coolant temperature gauge.....	39
4. Hourmeter, odometer and error code	39
5. Speedometer	40
6. Tachometer.....	40
PARKING THE VEHICLE.....	40
1. Parking brake lever.....	40

ACCESSORY.....	41
1. 12 V electric outlet.....	41
1.1 Electric outlet.....	41
1.2 Auxiliary power supply for relay coil 1.....	41
1.3 Auxiliary power supply for relay coil 2.....	41
1.4 Auxiliary power supply for relay coil 3.....	41
2. Utility box.....	42
3. Glove box and glove box cover (if equipped).....	42
OPERATING TECHNIQUES.....	42
1. Differential lock.....	42
2. Driving on unfamiliar terrain.....	43
3. Driving in reverse.....	43
4. Driving in “4WD”.....	43
5. Turning the vehicle.....	44
6. Driving on hills.....	44
7. Traversing hillsides.....	45
8. Sliding and skidding.....	45
9. Driving through water.....	45
CARGO BED.....	47
CARGO BED.....	47
1. Cargo bed general caution.....	47
2. Max. cargo bed load.....	47
3. Cargo bed tailgate.....	49
4. Raising and lowering the cargo bed.....	49
TIRES AND WHEELS.....	50
TIRES.....	50
1. Inflation pressure.....	50
2. Tire type and use.....	50
WHEELS.....	51
SHOCK ABSORBERS.....	51
1. Shock absorber spring adjustment.....	51
TOWING AND TRANSPORTING.....	53
TOWING AND TRANSPORTING.....	53
1. Rear trailer hitch (if equipped).....	53
2. Front trailer hitch (if equipped).....	53
3. Winch mount bracket.....	53
4. Transport the vehicle safely.....	54
MAINTENANCE.....	55
SERVICE INTERVALS.....	55
LUBRICANTS, FUEL AND COOLANT.....	58
PERIODIC SERVICE.....	60
HOW TO OPEN THE HOOD AND TILT THE SEAT.....	60
1. Hood.....	60
2. Seat.....	60
HOW TO RAISE THE CARGO BED.....	61
1. Raising and lowering the cargo bed.....	61
JACK-UP POINT.....	61
1. Front end.....	61
2. Rear end.....	61
DAILY CHECK.....	62
1. Walk around inspection.....	62
2. Checking around engine.....	62
3. Checking amount of fuel and refueling.....	62
4. Checking engine oil level.....	64

5. Checking transmission fluid level	64
6. Checking coolant level.....	65
7. Cleaning radiator screen	65
8. Checking drain cap	66
9. Checking brake fluid level.....	66
10. Checking brake pedal	66
11. Checking parking brake	67
12. Checking Easy Checker™	67
13. Checking head light, and so on	67
14. Checking seat belt, ROPS and door latch	67
15. Checking joint boot.....	67
16. Checking tire inflation pressure	68
17. Checking tire.....	69
EVERY 50 HOURS OR 1500 KM	69
1. Checking engine start system	69
2. Greasing	69
EVERY 100 HOURS OR 3000 KM	71
1. Checking wheel fastener torque	71
2. Checking brake pad wear	71
3. Cleaning air cleaner primary element.....	72
4. Changing engine oil.....	73
5. Checking fuel pump filter	73
6. Checking battery condition	74
6.1 Charging the battery.....	74
6.2 Directions for battery storage	76
7. Adjusting toe-in	76
8. Cleaning spark arrester	77
9. Checking exhaust system.....	77
10. Checking CVT belt.....	77
11. Checking the transmission gear shift switch	77
12. Checking carbon canister air filter (California only)	78
EVERY 200 HOURS OR 3000 KM	79
1. Checking the suspension arm bushings	79
EVERY 200 HOURS OR 6000 KM	79
1. Checking brake pedal	79
2. Checking brake light	79
3. Adjusting parking brake	79
4. Replacing engine oil filter	80
5. Checking spark plug condition and gap.....	80
6. Checking engine valve clearance.....	81
EVERY 400 HOURS OR 12000 KM	81
1. Changing transmission fluid	81
2. Changing front axle case oil	82
EVERY 500 HOURS OR 15000 KM	82
1. Checking purge valve (California only).....	82
EVERY 1000 HOURS OR EVERY YEAR.....	83
1. Replacing air cleaner primary element and secondary element.....	83
EVERY YEAR	83
1. Checking fuel line	83
2. Checking radiator hose, pipe and clamp	84
3. Checking intake air line	85
4. Checking CVT intake air line	86
5. Checking engine breather hose.....	86
6. Checking brake hose and pipe	87
EVERY 2 YEARS.....	87
1. Changing brake fluid.....	87
2. Flushing cooling system and changing coolant	87
3. Antifreeze	88

4. Replacing carbon canister air filter (California only)	89
EVERY 4 YEARS	89
1. Replacing radiator hose (water pipes)	89
2. Replacing fuel hose	89
3. Replacing engine breather hose	89
4. Replacing brake master cylinder (inner parts)	89
5. Replacing brake caliper (inner parts)	89
6. Replacing intake air line	89
7. Replacing brake hose and pipe	89
SERVICE AS REQUIRED	89
1. Replacing fuse	89
2. Replacing slow-blow fuses	90
3. Replacing light bulb	91
STORAGE	92
VEHICLE STORAGE	92
REMOVING THE VEHICLE FROM STORAGE	92
TROUBLESHOOTING	94
ENGINE TROUBLESHOOTING	94
ELECTRICAL SYSTEM TROUBLESHOOTING	96
BATTERY TROUBLESHOOTING	96
LIGHTING SYSTEM TROUBLESHOOTING	97
CVT TROUBLESHOOTING	97
STEERING TROUBLESHOOTING	97
BRAKE TROUBLESHOOTING	98
OPTIONS	99
LIST OF OPTIONS	99
EMISSION RELATED WARRANTY	100
INDEX	101

SAFE OPERATION

Careful operation is your best insurance against an accident.

Read and understand this operator's manual carefully before operating the vehicle.

All operators, no matter how much experience they may have, should read this and other related manuals before operating the vehicle or any implement attached to it. It is the owner's obligation to instruct all operators in safe operation.

BEFORE OPERATING THE VEHICLE

Know your equipment and its limitations. Read this entire manual before attempting to start and operate the vehicle.

1. General

- Pay special attention to the safety labels on the vehicle.
- Do not use a modified ROPS. Do not remove roll-over protective structures (ROPS) for any application and fasten seat belts at all times. This combination will reduce the risk of serious injury or death, should the vehicle be upset.
If the ROPS is loosened or removed for any reason, make sure that all parts are reinstalled correctly before operating the vehicle.
Never modify or repair a ROPS because welding, bending, drilling, grinding, or cutting may weaken the structure.
If any structural member of the ROPS is damaged, replace the entire structure at your local KUBOTA Dealer.
- Do not remove the side door or the side retention.

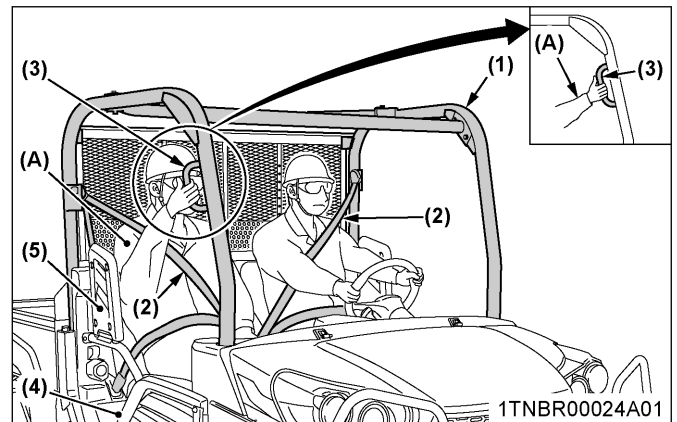

- (1) ROPS
- (2) Seat belt
- (3) Handhold
- (4) Side door
- (5) Side retention
- (A) Passenger

- Always use the seat belts. Check the seat belts regularly and replace if frayed or damaged.
- Do not operate the vehicle or any implement attached to it while under the influence of alcohol, medication, controlled substances or while fatigued.
- Carefully check the vicinity before operating the vehicle or any implement attached to it. Check for overhead clearance which may interfere with the CAB or ROPS. Do not allow any bystanders around or near the vehicle during operation.
- Never allow anyone under age 16 or without a valid driver's license to operate this vehicle.
- Before allowing other people to use your vehicle, explain how to operate and have them read this manual before operation.
- Never wear loose, torn, or bulky clothing around the vehicle. It may catch on moving parts or controls, leading to the risk of an accident. Use additional safety items, e.g. helmet, safety boots or shoes, eye and hearing protection, gloves, etc., as appropriate or required.
- This vehicle is for off-highway use only. KUBOTA does not recommend operating on public roads.
- In addition to the driver, only 1 passenger should ride in the vehicle.
Do not allow children to ride in the passenger's seat.
Do not carry small children on lap.
Passenger must be able to grasp the handhold with seat belt on and both feet on floor.
- Keep all shields in place and stay away from all moving parts.

SAFE OPERATION

- Check brakes, speed control pedal, and other mechanical parts for improper adjustment and wear. Replace worn or damaged parts promptly. Check the tightness of all nuts and bolts regularly. (See MAINTENANCE on page 55.)
- Keep your vehicle clean. Dirt, grease, and trash build up may contribute to fires and lead to personal injury.
- Use only implements meeting the specifications listed in this manual or implements approved by KUBOTA. (See VEHICLE LIMITATIONS on page 21.)
- The maximum cargo capacity of this vehicle
In the State of California: 272 kg (600 lbs.)
In the other 49 States: 454 kg (1000 lbs.)
Reduce cargo capacity to match operating conditions. Avoid top-heavy loading and ensure that the center-of-gravity remains as low as possible. Do not carry anything which sticks outside the cargo bed.
- Do not modify the vehicle. Unauthorized modification may affect the function of the vehicle, which may result in personal injury.
- Do not make any modifications to the engine or emission components as they may result in damage and malfunctions such as:
 - Damage to the power train from excessive engine output.
 - Engine overheating caused by exceeding the engine cooling performance capabilities.
 - Malfunctions of the exhaust gas aftertreatment control devices.Modifications to the engine and its emission components may violate emission regulations and are subject to fines and penalties. Kubota and its affiliates are not liable for any damage, malfunction or accidents caused by modifications to the engine or emission components.
- The vehicle does not provide protection against hazardous substances (dust, aerosol and vapor). Make sure to follow the available instructions of the personal protective equipment (PPE), plant protection products (PPP), sprayer manufacturer and the national guidelines for worker safety and health.
- The CAB is not tested for and does not meet falling object protective structure (FOPS) standards.

OPERATING THE VEHICLE

Operator safety is a priority. Safe operation, specifically with respect to overturning hazards, entails understanding the equipment and environmental conditions at the time of use.

Some prohibited uses which can affect overturning hazards include traveling and turning with implements and loads carried too high, and so on. This manual sets forth some of the obvious risks, but the list is not, and

cannot be, exhaustive. It is the operator's responsibility to be alert for any equipment or environmental condition that could compromise safe operation.

1. Starting to operate the vehicle

- Always sit in the operator's seat when starting engine or operating levers or controls. Never start engine while standing on the ground.
- Before starting the engine, make sure that all levers are in their neutral positions, that the parking brake is engaged.
- Do not start engine by shorting across starter terminals or bypassing the safety start switch. The vehicle may start in gear and move if normal starting circuitry is bypassed.
- Be sure that the operator (and passenger) are properly positioned and seat belts are appropriately fastened.
- Do not operate or idle engine in a non-ventilated area. Carbon monoxide gas is colorless, odorless, and deadly.

2. Operating the vehicle

- Always wear the seat belt when operating the unit.
- Do not wear headphones while operating.
- Pull only from the trailer hitch (if equipped). Never hitch to any other point except trailer hitch; such arrangements will increase the risk of serious personal injury or death due to a vehicle upset.

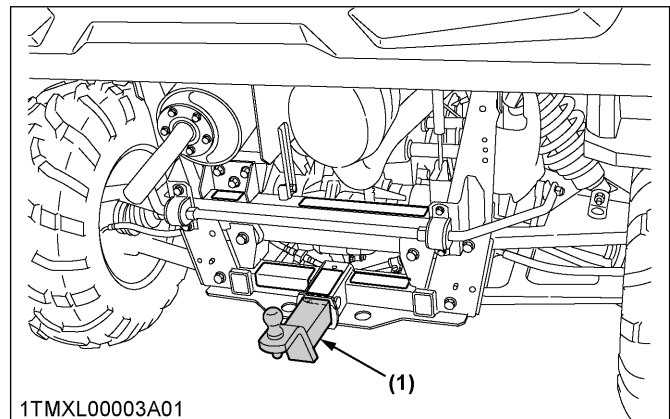

(1) Trailer hitch

- Keep all shields and guards in place. Replace any that are missing or damaged.
- Avoid sudden starts. To avoid rollovers, slow down when turning, on uneven ground, and before stopping. Operate the speed control pedal with great care to avoid sudden starts.
- The vehicle cannot turn with the differential locked and attempting to do so could be dangerous.
- Do not operate near ditches, holes, embankments, or other ground surface features which may collapse under the vehicle's weight. The risk of

vehicle upset is even higher when the ground is loose or wet.

- Watch where you are going at all times. Watch for and avoid obstacles. Be alert at row ends, near trees, and other obstructions.
- When working in groups, always let the others know what you are going to do before you do it.
- Never try to get on or off a moving vehicle.
- Do not stand between vehicle and trailer unless parking brake is applied.
- Do not operate the vehicle when there is a possibility of lightning. Even if the vehicle is equipped with a CAB, the operator is not protected from lightning.
- The RTV-XG850 (Sidekick) operates slightly different from other KUBOTA RTV series; it has more horsepower, a Continuously Variable Transmission (CVT) and a centrifugal clutch. As a result, the drive engages quickly and the unit may move or “jump” upon start up. Use caution when starting out.

3. Safety for children

Tragedy can occur if the operator is not alert to the presence of children. Children generally are attracted to vehicles and the work they do.

- Never assume that children will remain where you last saw them.
- Keep children out of the work area and under the watchful eye of another responsible adult.
- Be alert and shut your vehicle down if children enter the work area.
- Never carry children in the cargo bed. There is no safe place for them to ride. Do not allow children to ride in the passenger's seat. A passenger under 5 years of age requires special restraints which are not available with this vehicle.
- Never allow children to operate the vehicle even under adult supervision.
- Never allow children to play on the vehicle or on the implement.
- Use extra caution when backing up. Look behind and down to make sure area is clear before moving.

4. Operating on slopes

Slopes are a major factor related to loss-of-control and tipover accidents, which can result in severe injury or death. All slopes require extra caution.

- Travel straight up or down hill.
- Reduce load when operating on hilly or over rough terrain.
- Keep front wheels straight at crest of hill or going over bumps.

- Do not stop or start suddenly when going uphill or downhill. Be especially cautious when changing direction on slopes.
- If vehicle stops or loses power going up a hill, lock parking brake to hold vehicle on slope. Maintain direction of travel and release brake slowly. Back straight downhill while maintaining control. Do not turn vehicle sideways. Vehicle is more stable in a straight forward or rearward position.
- When riding on soft terrain, turn front wheels slightly uphill to keep vehicle on a straight line across the hill.
- If the vehicle begins to tip, turn front wheels downhill to gain control before proceeding.
 1. To avoid upsets, always back up steep slopes. If you cannot back up the slope or if you feel uneasy on it, do not operate on it. Stay off slopes too steep for safe operation.
 2. Driving forward out of a ditch, mired condition or up a steep slope increases the risk of a vehicle to be upset backward. Always back out of these situations. Extra caution is required with 4-wheel drive mode because the increased traction can give the operator false confidence in the vehicle's ability to climb slopes.
 3. Keep all movement on slopes slow and gradual. Do not make sudden changes in speed, direction or apply brake and make sudden motions of the steering wheel.
 4. Special attention should be made to the weight and location of implements and loads as such will affect the stability of the vehicle.

5. Operation in inclement conditions

- Only operate during daylight or with good artificial light.
- Operate vehicle in an open, unobstructed area.
- Use helmet and/or protective gear as appropriate or required for the operating conditions.
- Reduce speed according to trail, terrain and visibility conditions.
- Never drive exceeding the limit of visibility. Slow down near crest of hill until getting a clear view of the other side.
- Stay alert for holes, rocks and other hidden hazards in the terrain.
- Never cross any body of water where depth may be unknown to the operator (Deep water is considered anything in excess the bottom edge of the axle cap). Choose a course within the waterway where both banks have a gradual incline. Cross at a point known to be safe.

SAFE OPERATION

6. Driving the vehicle at high speeds

- Check the front wheel engagement. The braking characteristics are different between 2 and 4 wheel drive. Be aware of the difference and use carefully.
- Always slow the vehicle down before turning. Turning at high speed may tip the vehicle over.
- Turn the headlights on. Dim them when meeting another vehicle.
- Drive at speeds that allow you to maintain control at all times.
- Do not apply the differential lock while traveling at high speeds. Locking the differential affects vehicle control and may cause loss of control.
- Avoid sudden motions of the steering wheel as they can lead to a dangerous loss of stability. The risk is especially great when the vehicle is traveling at high speeds.

7. Other miscellaneous

- Clean platform if dirty and remove any debris from around foot controls.
- Always keep both hands on the steering wheel.
- Always keep arms and legs inside the operating compartment.
- Never operate the vehicle while standing.
- Do not tow a trailer with any riders on it.
- Never attempt wheelies, jumps or other stunts.

HAULING LOADS IN THE CARGO BED

- No riders in cargo bed or anywhere else.
- Do not overload vehicle. Securely anchor all loads.
- Reduce cargo capacity when operating on rough or hilly terrain.
- Position cargo toward the front and center of the cargo bed and as evenly distributed as possible.
- Securely anchor all loads in the cargo bed. Braking could shift the load and affect vehicle stability.
- Never operate vehicle with the cargo bed raised.
- Operate cargo bed dump with vehicle stationary and parking brake locked. Do not dump while moving.
- Operate the cargo bed dump on level ground only.
- Operate electric dump (if equipped) from operator's seat only.
- Do not place hands or body under the cargo bed when lowering bed.
- Stability is decreased while loaded.
- Braking distance increases while loaded. Always take into account the change in the vehicle CG (center of gravity) when operating with a load.

TOWING

- Stability is decreased while towing.
- Braking distance increases while towing.
- Do not exceed the set maximum towing weight of this vehicle.
(See VEHICLE LIMITATIONS on page 21.)
- Securely fasten the load while towing.
- Set the range gear shift lever to the [L] position before towing.

PARKING THE VEHICLE

- Lower all implements to the ground, place all control levers in their neutral positions, set the parking brake, stop the engine, and remove the key.
- Make sure that the vehicle has come to a complete stop before dismounting.
- Avoid parking on steep slopes, if at all possible park on a firm and level surface; if not, park across a slope, chock the wheels and always with attachment on the ground.
Failure to comply with this warning may allow the vehicle to move and could cause injury or death.

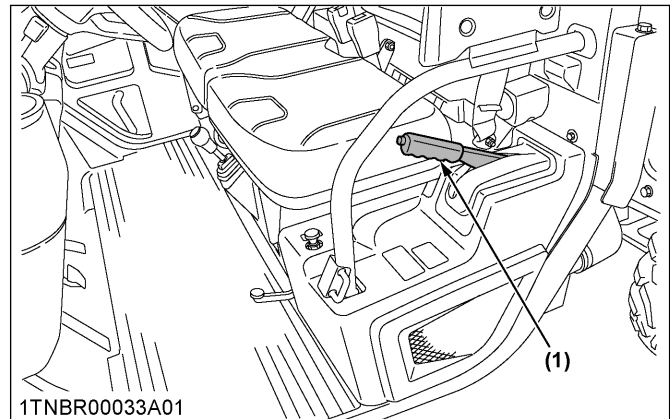

(1) Parking brake lever

TRANSPORTING THE VEHICLE

- Disengage power to attachment(s) when transporting or not in use.
- Do not tow this vehicle. Use a suitable truck or trailer when transporting on public roads.
- Use extra care when loading or unloading the vehicle into a trailer or truck.

SERVICING THE VEHICLE

Before servicing the vehicle, park it on a firm, flat and level surface, set the parking brake, lower all implements to the ground, place the range gear shift lever in neutral, stop the engine and remove the key.

! SAFE OPERATION

- Allow the vehicle time to cool off before working on or near the engine, muffler, radiator, etc.
- Always stop the engine before refueling. Avoid spills and overfilling.
- Do not smoke when working around battery or when refueling. Keep all sparks and flames away from battery and fuel tank. The battery presents an explosive hazard, because it gives off hydrogen and oxygen especially when recharging.
- Before "jump starting" a dead battery, read and follow all of the instructions. (See JUMP STARTING on page 29.)
- Keep first aid kit and fire extinguisher handy at all times.
- Disconnect the battery's ground cable before working on or near electric components.
- To avoid the possibility of battery explosion, do not use or charge the refillable type battery if the fluid level is below the **[LOWER]** (lower limit level) mark. Check the fluid level regularly and add distilled water as required so that the fluid level is between the **[UPPER]** and **[LOWER]** marks.
- To avoid sparks from an accidental short circuit, always disconnect the battery's ground cable (-) first and reconnect it last.

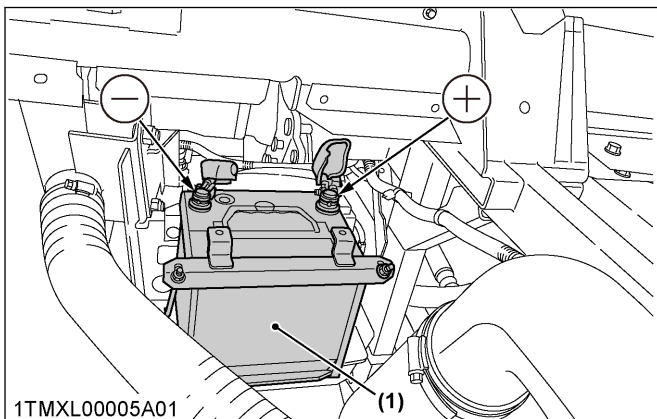

(1) Battery

- Do not remove radiator cap while coolant is hot. When cool, slowly rotate cap to the first stop and allow sufficient time for excess pressure to escape before removing the cap completely. This vehicle has a coolant recovery tank, add coolant or water to the tank, not the radiator. (See Checking coolant level on page 65.)
- Do not attempt to mount a tire on a rim. This should be done by a qualified person with the proper equipment.
- Always maintain the correct tire pressure. Do not inflate tires above the recommended pressure shown in the operator's manual.

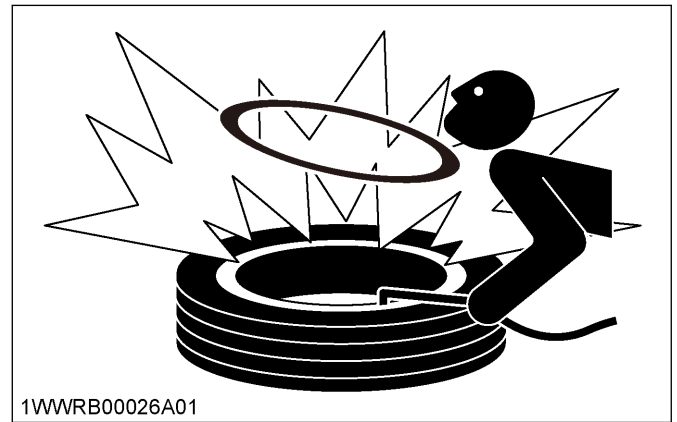



- Securely support the vehicle when changing wheels.
- Make sure that wheel bolts and nuts have been tightened to the specified torque.
- Do not work under any hydraulically supported devices. They can settle, suddenly leak down, or be accidentally lowered. If it is necessary to work under the vehicle or any vehicle elements for servicing or adjustment, securely support them with stands or suitable blocking beforehand.
- Waste products such as used oil, fuel, hydraulic fluid, and batteries, can harm the environment, people, pets and wildlife. Please dispose properly. See your local recycling center or KUBOTA Dealer to learn how to recycle or get rid of waste products.

⚠️ SAFE OPERATION

SAFETY LABELS

(1) Part No. K7811-6522-1

		⚠️ DANGER
<p>TO AVOID POSSIBLE INJURY OR DEATH FROM A MACHINE RUNAWAY:</p> <ol style="list-style-type: none"> 1. Do not start engine by shorting across starter terminals or bypassing the safety start switch. The vehicle may start in gear and move if normal starting circuitry is bypassed. 2. Start engine only from operator's seat with range shift lever in neutral position. 		

1TMXL00087A01

(2) Part No. K7591-6541-1

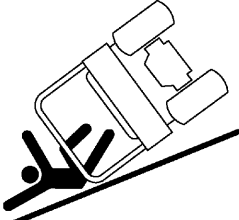
⚠️ WARNING

<p>TO AVOID PERSONAL INJURY OR DEATH:</p> <ol style="list-style-type: none"> 1. Do not remove Roll-Over Protective Structures (ROPS) for any application. 2. Do not modify or repair a ROPS because welding, grinding, drilling or cutting any portion may weaken the structure.

1AYAACQAP006A

(3) Part No. K7421-6526-1

⚠️ WARNING	
	<p>TO AVOID PERSONAL INJURY OR DEATH: Always fasten your seat belt.</p>
⚠️ WARNING	
<p>TO AVOID PERSONAL INJURY DUE TO LOSS OF STEERING CONTROL: Do not depress the differential lock pedal at high speed.</p>	

1AYAACQAP184A

(4) Part No. K7811-6528-1

⚠️ WARNING
<p>TO AVOID PERSONAL INJURY OR DEATH: Do not operate the vehicle with the front hood open. Impaired visibility of the operator may cause loss of vehicle control. Latch the hood securely before operating the vehicle.</p>







1TMXL00088A01

(6) Part No. K7421-6577-2

⚠️ WARNING	
<p>TO AVOID PERSONAL INJURY OR DEATH: Secure the door properly.</p>	

1AYAACQAP021A

(5) Part No. K7811-6113-2

			<p>DANGER EXPLOSIVE GASES CIGARETTES, FLAMES OR SPARKS COULD CAUSE BATTERY TO EXPLODE. ALWAYS SHIELD EYES AND FACE FROM BATTERY. DO NOT CHARGE OR USE BOOSTER CABLES OR ADJUST POST CONNECTIONS WITHOUT PROPER INSTRUCTION AND TRAINING.</p>
FLAMMABLES	SHIELD EYES	KEEP OUT OF THE REACH OF CHILDREN	<p>POISON CAUSES SEVERE BURNS CONTAINS SULFURIC ACID. AVOID CONTACT WITH SKIN, EYES OR CLOTHING. IN EVENT OF ACCIDENT FLUSH WITH WATER AND CALL A PHYSICIAN IMMEDIATELY.</p>
			<p>KEEP OUT OF REACH OF CHILDREN ⚠️ California Proposition 65 WARNING : This product can expose you to chemicals including lead, which is known to the State of California to cause cancer and birth defects or other reproductive harm. For more information go to www.P65Warnings.ca.gov.</p>
CAUTIOUS OF SULFURIC ACID	READ INSTRUCTION MANUAL CAREFULLY	EXPLOSIVE	

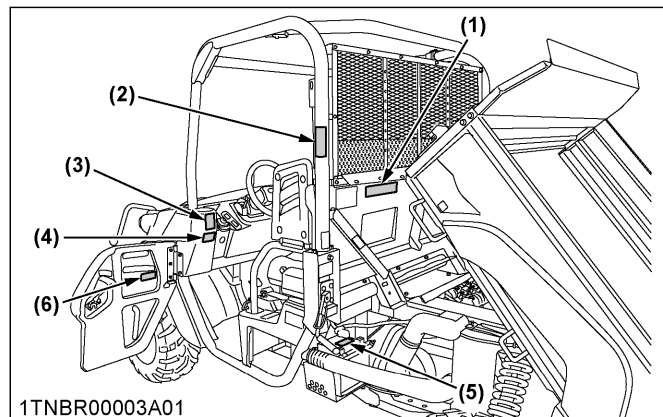

1TNBR00026A01enUS

! SAFE OPERATION

(1) Part No. K7811-6524-2

! WARNING

TO AVOID PERSONAL INJURY OR DEATH:

1. Use brake fluid(DOT-3) only. Other oil types will ruin synthetic resin or rubber installed in brake system components, and cause brake failure.
2. If brake fluid is spilled on other parts, wash off with water immediately. Brake fluid quickly ruins synthetic resin or rubber parts.

1TMXL00089A01

(2) Part No. K7591-6544-2

! WARNING

TO AVOID PERSONAL INJURY: Attach pulled or towed loads to the drawbar only.

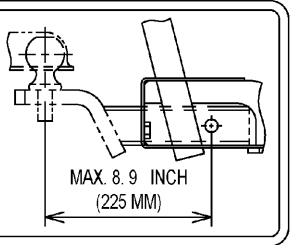

MAX. 8.9 INCH
(225 MM)

1AYAACQAP007A

(3) Part No. K7811-6521-3

! WARNING

TO AVOID PERSONAL INJURY OR DEATH:

1. Read and understand the operator's manual before operation.
2. Never allow anyone under age 16 or without a valid driver's license to operate this vehicle.
3. Before allowing other people to use the vehicle, have them read the operator's manual.
4. This vehicle is for off-highway use only. Never operate on a public road, as such operation could be a violation of the law and may be hazardous.
5. Wear safety gear, including helmet and eye protection, as appropriate.
6. Check the tightness of all nuts and bolts regularly.
7. In addition to the driver, only one passenger can be carried. Do not allow children to ride in the passenger's seat. Passenger must be able to grasp the handhold with seat belt on and both feet on floor.
8. Before starting the engine, make sure that everyone is at a safe distance from the vehicle.
9. Do not operate the vehicle under the influence of drugs or alcohol.
10. Keep all shields in place and stay away from all moving parts.
11. Slow down for turns, or rough terrain.
12. Before getting off from the vehicle, apply the parking brake, stop the engine and remove the key.
13. Do not operate unless driver and passenger are properly positioned and seat belts appropriately fastened.

1TMXL00090A01

(4) Part No. K7421-6527-1

! WARNING

TO AVOID PERSONAL INJURY OR DEATH: Always fasten your seat belt.



1AYAACQAP185A

(5) Part No. K7421-6577-2

! WARNING

TO AVOID PERSONAL INJURY OR DEATH: Secure the door properly.



1AYAACQAP021A

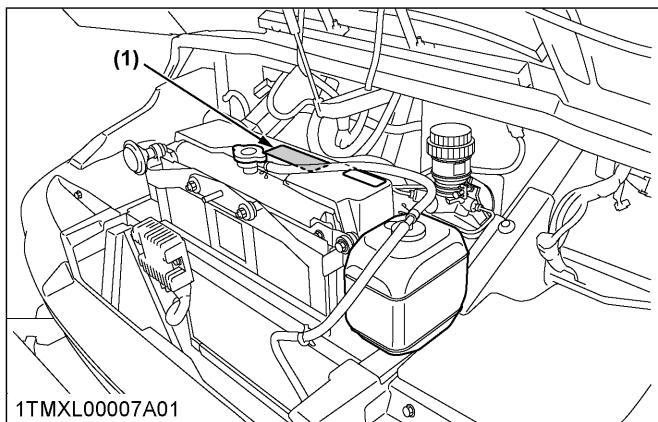

(6) Part No. K7591-6596-1

California Proposition 65

! WARNING: Operating, servicing and maintaining off road equipment or off road vehicles can expose you to inhalation of or contact with chemicals including engine exhaust, carbon monoxide, phthalates, and lead which are known to the state of California to cause cancer and birth defects or other reproductive harm. To minimize exposure:

- Avoid breathing exhaust.
- Always start and operate the engine in a well ventilated area.
- If in an enclosed area, vent the exhaust to the outside.
- Do not modify or tamper with the exhaust system.
- Do not idle the engine except as necessary.
- Service your equipment or vehicle in a well ventilated area.
- Wear gloves or wash your hands frequently when servicing your equipment or vehicle.

For more information go to: WWW.P65warnings.ca.gov

1TMXL00115A01

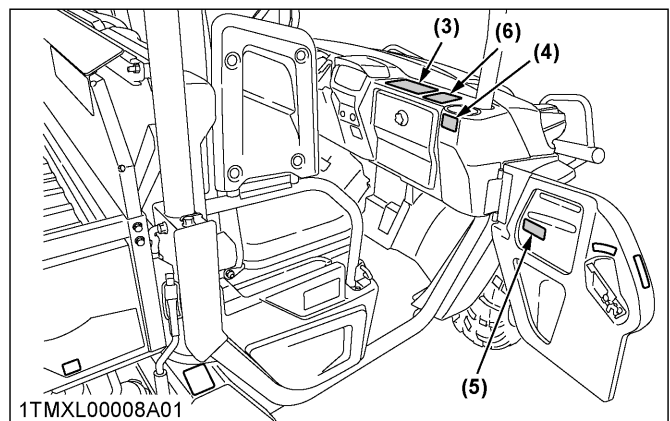
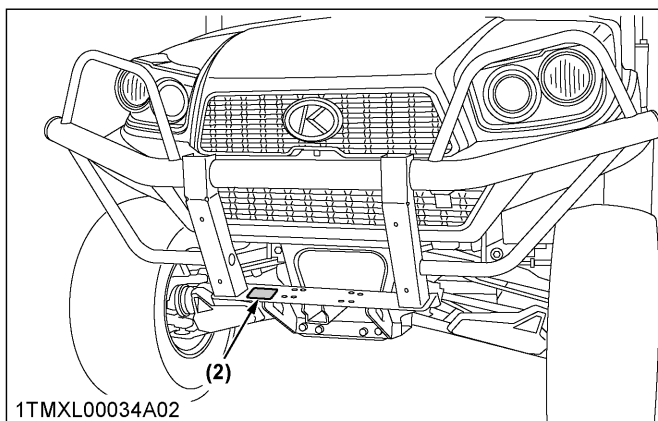

⚠️ SAFE OPERATION

(1) Part No. K7811-6542-1



⚠️ WARNING

TO AVOID PERSONAL INJURY OR DEATH:
Use the Safety Support or Propping Rod when working near a raised cargo bed or attachment.

1TMXL00092A01

(2) Part No. K7811-6574-2

⚠️ WARNING

TO AVOID PERSONAL INJURY OR DEATH:

1. Before touching any part of an exhaust system, be absolutely sure that it has had sufficient time to cool.

2. Always wear safety goggles and a (face)mask.
3. The particulate matter contained in the muffler contains chemicals that are harmful to people, animal and marine life.
4. If you are unable to do this work, have it done by your KUBOTA Dealer.

1TMXL00093A01

(3) Part No. K7811-6572-2

- Hot surface - burn to finger or hand
- Do not touch muffler while surface is hot.

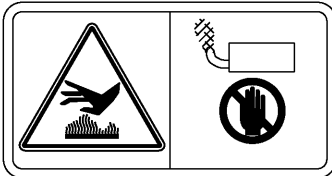

1TMXL00094A01

(4) Part No. K7811-6587-2

⚠️ WARNING

TO AVOID PERSONAL INJURY OR DEATH:
Attach pulled or towed loads to the drawbar only.

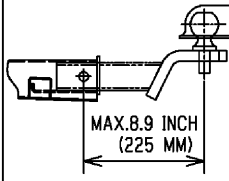

MAX.8.9 INCH
(225 MM)

1TMXL00112A01

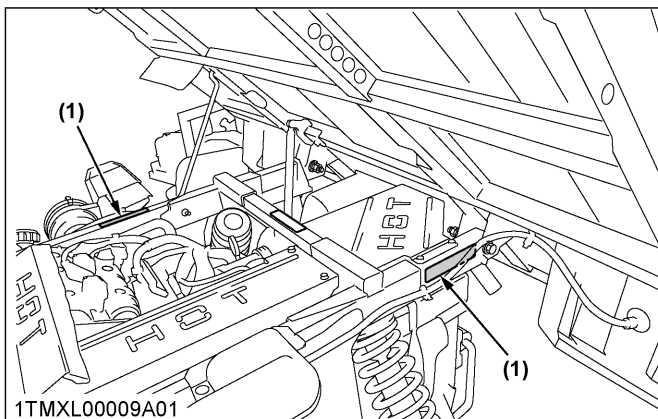

1TMXL00009A01

1TMXL00102A01enUS

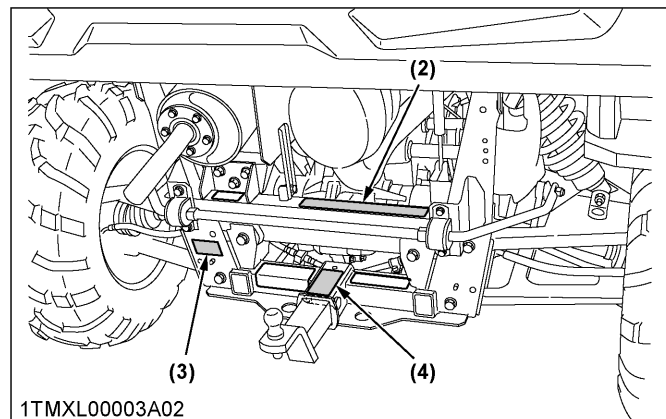

1TMXL00003A02

⚠️ SAFE OPERATION

(1) Part No. K7811-6591-4 (Except for California model)

<p>⚠️ WARNING</p>  <p>TO AVOID PERSONAL INJURY OR DEATH:</p> <ol style="list-style-type: none">1. Do not place gas container inside the cargo box when filling.2. Place gas container on ground when filling.	<p>⚠️ WARNING</p> <p>TO AVOID PERSONAL INJURY OR DEATH:</p> <ol style="list-style-type: none">1. Do not carry passengers in cargo bed.2. Do not travel with the cargo bed in raised position.3. Do not overload the cargo bed. <p>IMPORTANT</p> <p>Max. cargo load should not exceed "CBC" or "CL".</p> <p>CBC(Cargo Bed Capacity) : 454 kg (1000 lbs)</p> <p>CL(Cargo Load) : May vary on models. Refer to operator's manual for details.</p> <p>CL = (payload capacity) - (operator+passenger+opt.+acc.+cabin)weight</p>
---	---

1TMXL00095A01

(1) Part No. K7812-6591-2 (California model)

<p>⚠️ WARNING</p>  <p>TO AVOID PERSONAL INJURY OR DEATH:</p> <ol style="list-style-type: none">1. Do not place gas container inside the cargo box when filling.2. Place gas container on ground when filling.	<p>⚠️ WARNING</p> <p>TO AVOID PERSONAL INJURY OR DEATH:</p> <ol style="list-style-type: none">1. Do not carry passengers in cargo bed.2. Do not travel with the cargo bed in raised position.3. Do not overload the cargo bed. <p>IMPORTANT</p> <p>Max. cargo load should not exceed "CBC" or "CL".</p> <p>CBC(Cargo Bed Capacity) : 272 kg (600 lbs)</p> <p>CL(Cargo Load) : May vary on models. Refer to operator's manual for details.</p> <p>CL = (payload capacity) - (operator+passenger+opt.+acc.+cabin)weight</p>
---	--

1TMXL00096A01

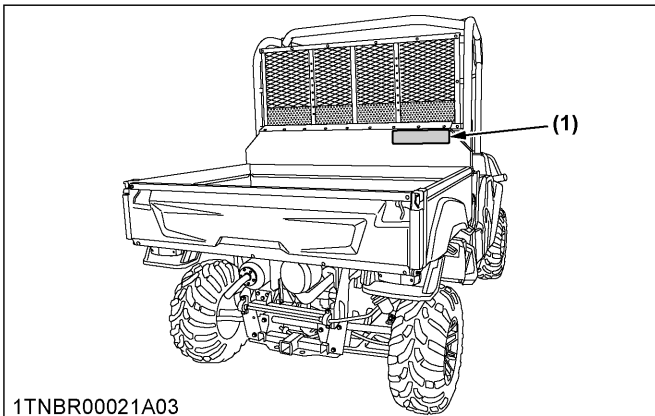

1TNBR00021A03

1TNBR00027A01enUS

SAFE OPERATION

(1) Part No. K7811-6531-1

 WARNING

Operation of this equipment may create sparks that can start fires around dry vegetation. A spark arrester may be required. The operator should contact local fire agencies for laws or regulations relating to fire prevention requirements.

1TMXL00099A01

(2) Part No. K7811-6538-1



WARNING

NO STEP

1TMXL00097A01

(3) Part No. K7811-6534-1

 WARNING

DO NOT FUEL WITH PASSENGERS PRESENT





GASOLINE ONLY

• No fire

1TMXL00098A01

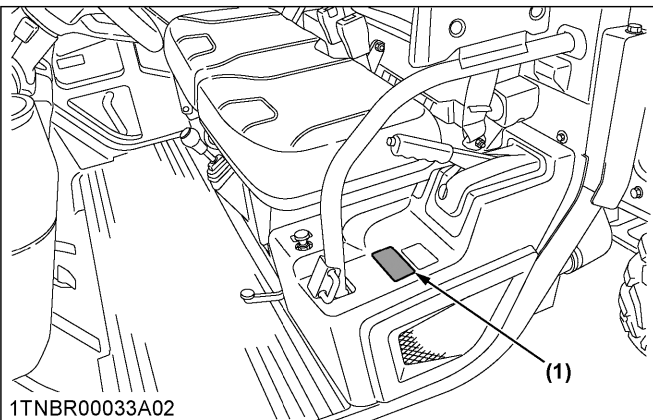

1TNBR00033A02

1TNBR00028A01enUS

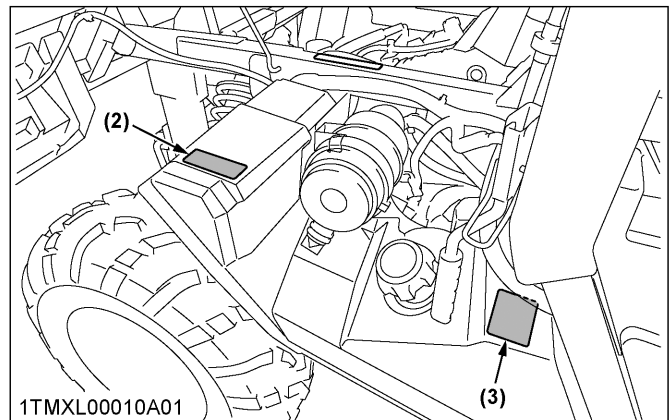

1TMXL00010A01

CARE OF SAFETY LABELS

- Keep safety labels clean and free from obstructing material.
- Clean safety labels with soap and water, and dry with a soft cloth.
- Replace damaged or missing safety labels with new labels from your local KUBOTA Dealer.
- If a component with safety label(s) attached is replaced with a new part, make sure new label(s) is (are) attached in the same location(s) as the replaced component.
- Attach new safety labels by applying on a clean dry surface and pressing any bubbles to the outside edge.

SERVICING OF VEHICLE

Your dealer has knowledge of your new vehicle and has the desire to help you get the most value from it. After reading this manual thoroughly, you will find that you can do some of the regular maintenance by yourself.

However, when in need of parts or major service, see your KUBOTA Dealer.

For service, contact the KUBOTA Dealership from which you purchased your vehicle or your local KUBOTA Dealer.

When in need of parts, be prepared to give your dealer the product identification number (PIN), and the serial number of the vehicle, engine, transmission and ROPS. Locate the PIN and serial numbers now and record them in the space provided.

Product identification number	
Date of purchase	
Name of dealer	

	Serial number
Engine	
Transmission	
ROPS	

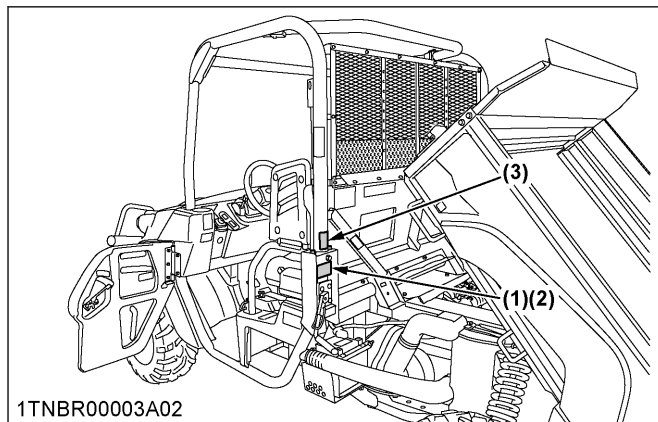

- (1) Vehicle identification plate
- (2) Product identification number
- (3) ROPS serial number

*** Vehicle type on (1)**

Model	Vehicle type
Except for California model	RTV-XG850
California model	RTV-XG850 EVAP

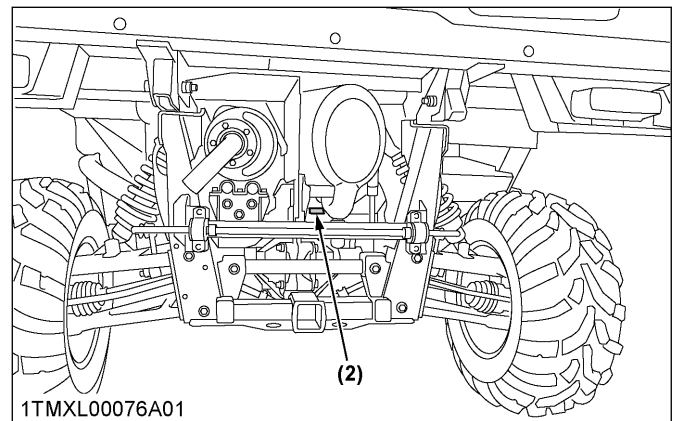
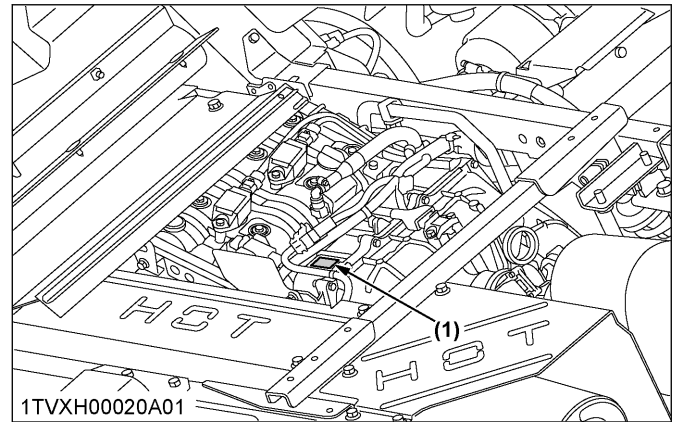

- (1) Engine serial number
- (2) Transmission assy serial number

WARRANTY

This vehicle is warranted under the **KUBOTA Limited Express Warranty** a copy of which may be obtained from your selling dealer. No warranty shall, however, apply if the vehicle has not been handled according to the instruction given in the operator's manual even it is within the warranty period.

SCRAPPING THE VEHICLE

To put the vehicle out of service, follow the local rules and regulations of the country or territory where you scrap it. If you have questions, consult your local KUBOTA Dealer.

REPORTING SAFETY CONCERNS IN CANADA

To report a safety concern relating to your vehicle, you may contact Transport Canada at the following:

Telephone:

819-420-4300 (Ottawa-Gatineau area or internationally)

Toll free: 1-800-333-0510 (in Canada)

Online:

<http://www.tc.gc.ca/recalls> (ENGLISH)

<http://www.tc.gc.ca/rappels> (FRENCH)

SPECIFICATIONS

SPECIFICATION TABLE

Model			RTV-XG850		RTV-XG850 EVAP		
			49 states		California		
			General Purpose	Worksite	General Purpose	Worksite	
Engine	Model		GZ850H-EM-UV		GZ850H-EM-UVC		
	Type		2 cylinder DOHC, 4-cycle, Liquid-cooled, EFI Gas				
	Displacement	L (cu. in.)	0.851 (51.9)				
	Low idling revolution	rpm	1200 to 1300				
Fuel capacity*1		L (U.S.gals)	31.9 (8.4)				
Transmission			Continuously variable transmission (CVT) with inertial clutch				
Wheels, drive system			4, Rear 2WD or 4WD				
Differential lock			Front: LSD Rear: foot operated				
Gear selection			Hi-Low range forward, neutral, reverse				
Brakes	Front/rear		Dry disk brake				
	Parking brake		Rear mechanical/hand operated				
Steering			EPS (Electric power steering)				
Suspension	Front		4 wheel independent suspension				
	Rear						
Dimensions	Length	mm (in.)	2973 (117)	3093 (119.6)	2973 (117)	3093 (119.6)	
	Width	mm (in.)	1605 (63.2)				
	Height, overall	mm (in.)	2020 (79.5)				
	Front tread centers	mm (in.)	1320 (52)				
	Rear tread centers	mm (in.)	1320 (52)				
	Wheelbase	mm (in.)	2045 (80.5)				
	Ground clearance	front axle	mm (in.)	249 (9.8)			
		rear axle	mm (in.)	251 (9.9)			
Turning diameter		m (ft)	8.0 (26.2)				
Max. rolling weight (towing capacity)		kg (lbs.)	Level ground: 907.2 (2000) Steep ground: 703 (1550)				
Payload capacity		kg (lbs.)	656 (1446)	639 (1408)	653 (1439)	636 (1402)	
Weight (with fuel and fluids)		kg (lbs.)	841 (1854)	858 (1892)	844 (1861)	861 (1898)	
Gross Vehicle Weight Rating (GVWR)		kg (lbs.)	1497 (3300)				
Cargo bed	Width	mm (in.)	1465 (57.5)				
	Length	mm (in.)	1030 (40.5)				
	Depth	mm (in.)	290 (11.4)				
	Volume	m ³ (cu.ft.)	0.43 (15.2)				

(Continued)

Model			RTV-XG850		RTV-XG850 EVAP	
			49 states		California	
			General Purpose	Worksite	General Purpose	Worksite
Cargo bed	Bed height (unloaded)	mm (in.)	887 (34.9)			
	Cargo bed capacity	kg (lbs.)	454 (1000)		272 (600)	
Tires	Front		25×10-12 ATV 25×10-12 HDWS			
	Rear		25×10-12 ATV 25×10-12 HDWS			
Tilt steering wheel			—	Standard	—	Standard
Seat belt			3 point type			
Front guard			—	Standard	—	Standard
Glove box cover			—	Standard	—	Standard
Cargo assist gas spring			—	Standard	—	Standard

*1 Measured by manufacturer

NOTE :

- The company reserves the right to change the specifications without notice.
- The values in “Ground clearance” and “Weight” are those of the machine equipped with the tires in the table above.

TRAVELING SPEEDS

Range gear shift lever position	RTV-XG850/RTV-XG850 EVAP	
	Traveling speeds km/h (mph)	
LOW	40.6 (25.2)	
HIGH	64.4 (40)	
REVERSE	35.0 (21.7)	

VEHICLE LIMITATIONS

The KUBOTA Vehicle has been thoroughly tested for proper performance with implements sold or approved by KUBOTA.

Use with implements below may result in malfunctions or failures of the machine, damage to other property and injury to the operator or others.

- Implements which are not sold or approved by KUBOTA
- Implements which exceed the maximum specifications listed below, or
- Implements which are otherwise unfit for use with the KUBOTA Vehicle

Any malfunctions or failures of the vehicle resulting from use with improper implements are not covered by the warranty.

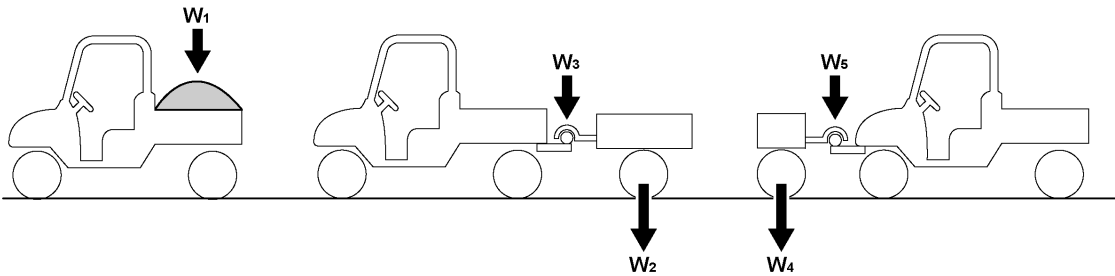
Cargo bed	<p>Max. cargo bed loading weight (W1) should not exceed "CBC" and "PCBL". CBC (cargo bed capacity):</p> <ul style="list-style-type: none"> • Expect for California model: 454 kg (1000 lbs.) • California model: 272 kg (600 lbs.) <p>PCBL (permissible cargo bed load) is determined by the following calculus equation. PCBL = PC - (operator + passenger + opt. + acc.) weight</p> <p>PC: payload capacity opt.: option acc.: accessory</p>
Rear trailer hitch	<p>Max. rolling weight (W2): 907 kg (2000 lbs.) (level ground) *1 Max. rolling weight (W2): 703 kg (1550 lbs.) (steep ground) *1 Max. tongue weight (W3): 50 kg (110 lbs.) *2</p>
Front trailer hitch (if equipped)	<p>Max. rolling weight (W4): 295 kg (650 lbs.) Max. tongue weight (W5): 50 kg (110 lbs.)</p>
 <p>1TGYP00018A01</p>	

*1 Including W3

*2 Including W5

Rolling weight: Trailer weight + Trailer cargo load

- Above mentioned specifications are based on level ground condition.

Payload capacity (PC)

Model	RTV-XG850		RTV-XG850 EVAP	
	General purpose model	Worksite model	General purpose model	Worksite model
Payload capacity	656 kg (1446 lbs.)	639 kg (1408 lbs.)	653 kg (1439 lbs.)	636 kg (1402 lbs.)

INSTRUMENT PANEL AND CONTROLS

LOCATION OF PARTS

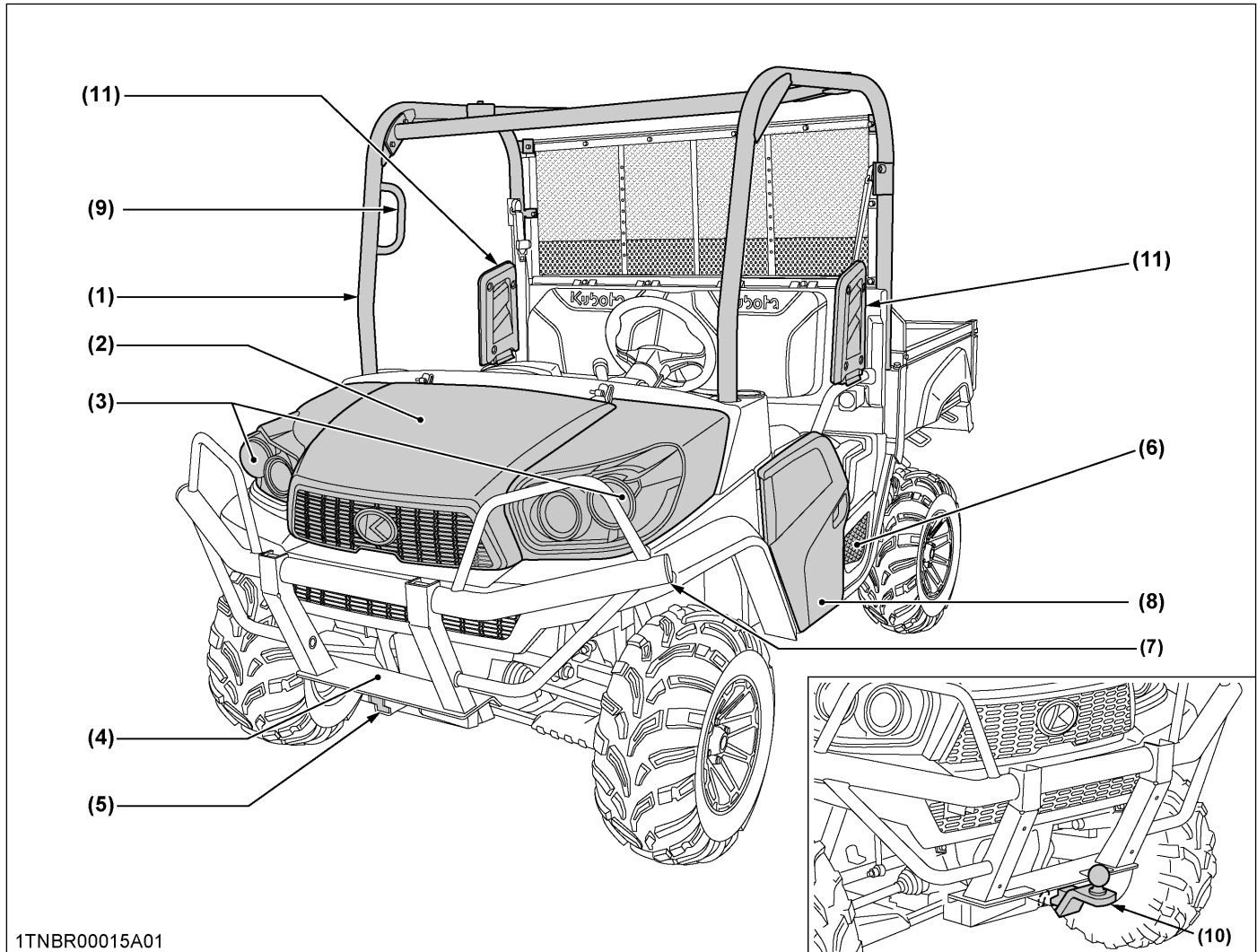

1TNBR00015A01

Illustrated contents

(1) ROPS	60
(2) Front hood	34
(3) Headlight	53
(4) Winch mount bracket	53
(5) Front trailer hitch bracket	74
(6) Battery	33
(7) Front guard (if equipped)	
(8) Door	
(9) Handhold	
(10) Front trailer hitch (if equipped)	53
(11) Side retention	

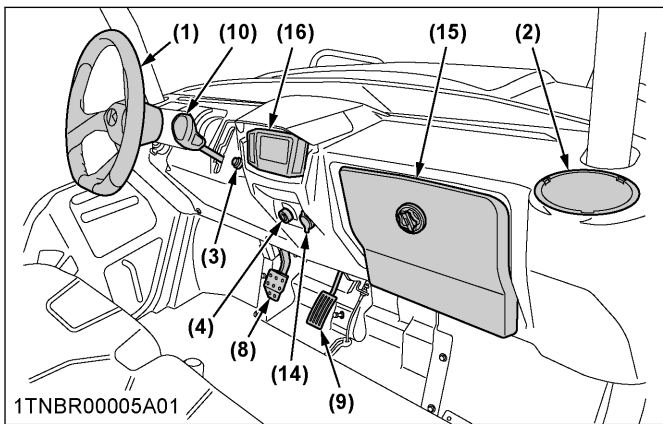

Illustrated contents

- (1) Steering wheel
- (2) Cup holder
- (3) Horn button..... 35
- (4) Key switch..... 27
- (5) Turn signal light switch (if equipped)
- (6) Head light switch..... 34
- (7) Hazard light switch (if equipped)..... 34
- (8) Brake pedal..... 36
- (9) Speed control pedal..... 37
- (10) Range gear shift lever..... 36
- (11) Tilt lever (if equipped) 34
- (12) Front work light switch (if equipped)
- (13) Electric bed lift switch (if equipped)
- (14) 12 V accessory plug 41
- (15) Glove box cover (if equipped)..... 42
- (16) Liquid crystal display..... 38

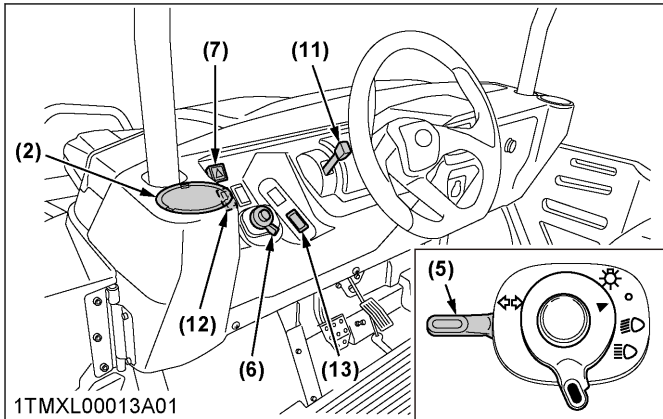

Illustrated contents

- (1) Seat belts..... 34
- (2) Seat 60
- (3) 4WD lever..... 37
- (4) Differential lock pedal 42
- (5) Differential lock holder 42
- (6) Parking brake lever..... 37

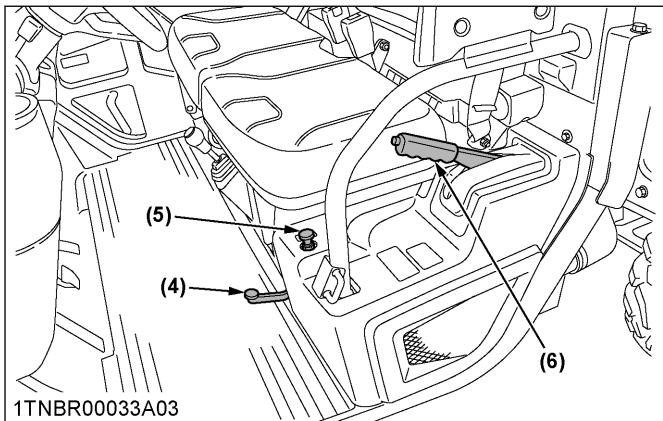
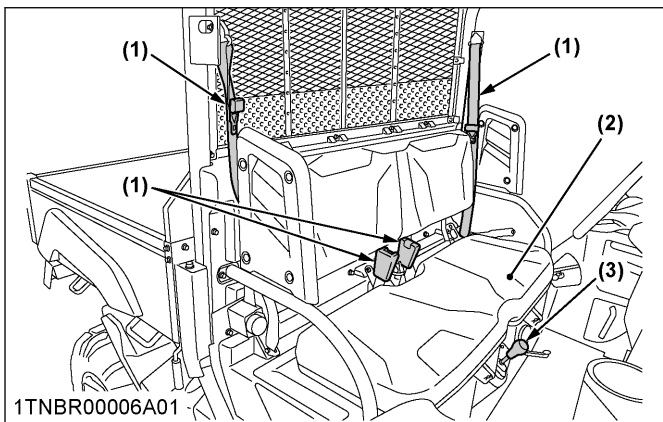

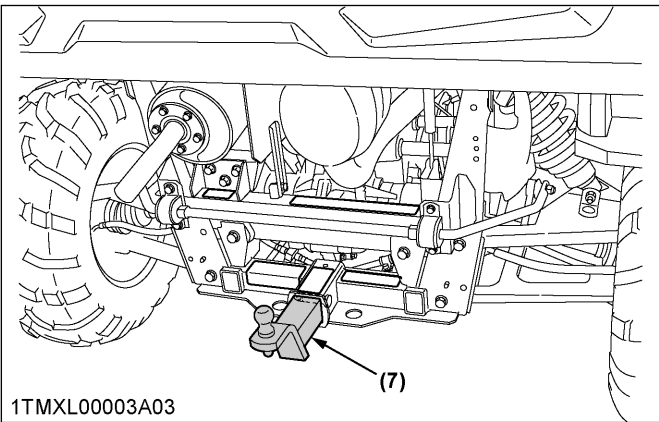
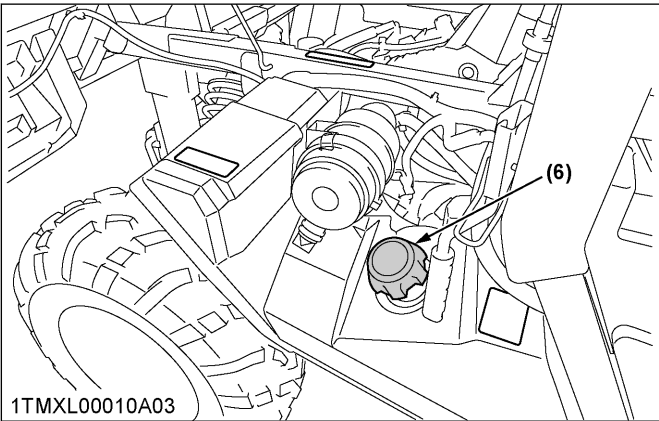
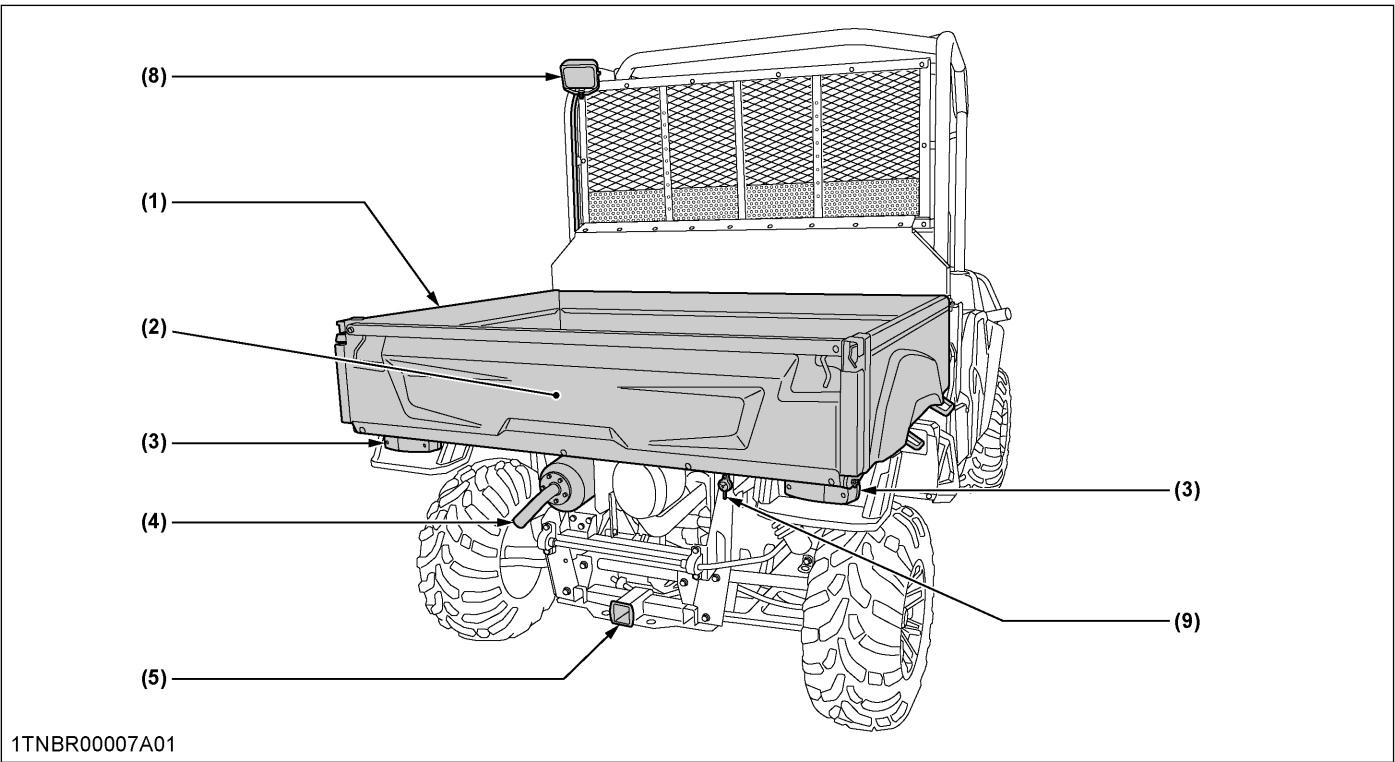

Illustrated contents

(1) Cargo bed	47
(2) Tailgate	49
(3) Tail lamp (Combination lamp if equipped)	34
(4) Muffler	77
(5) Rear trailer hitch bracket	53
(6) Fuel tank cap	62
(7) Rear trailer hitch (if equipped)	53
(8) Rear work light (if equipped)	
(9) Backup beeper (if equipped)	

INSTRUMENT PANEL

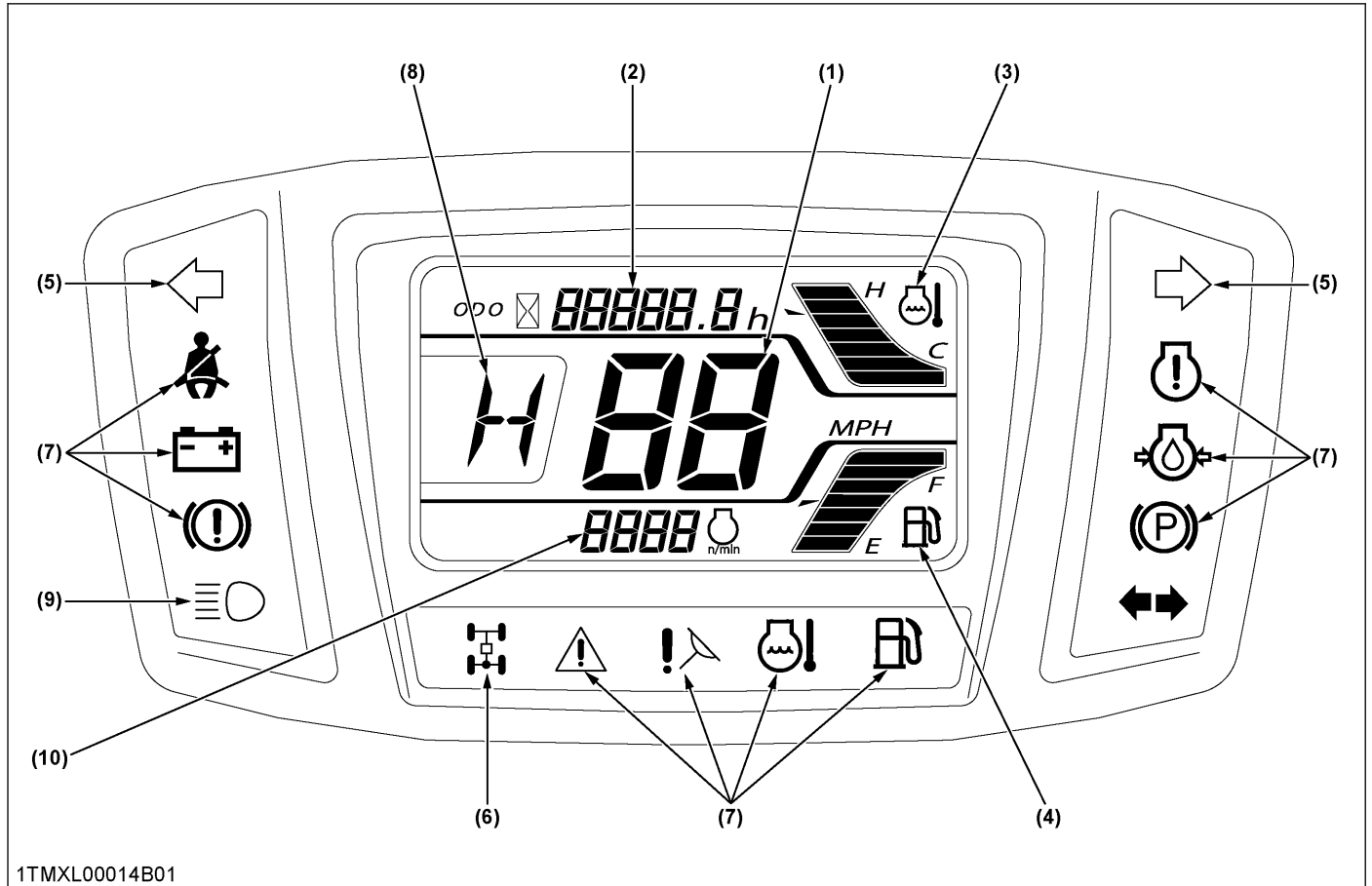

1TMXL00014B01

Illustrated contents

(1) Speedometer	40	(6) 4WD indicator	37
(2) Hourmeter / odometer / error code	39	(7) Easy Checker™	38
(3) Coolant temperature gauge	39	(8) Range gear shift position	36
(4) Fuel gauge	39	(9) High beam indicator	40
(5) Turn signal indicator (if equipped)/Hazard signal indicator (if equipped)	36	(10) Tachometer	40

PRE-OPERATION CHECK

DAILY CHECK

To prevent trouble from occurring, it is important to know the condition of the vehicle well. Check it before starting.



WARNING

To avoid serious injury or death:

- Check and service the vehicle on a level surface with the engine shut off and the parking brake “ON” and implement lowered to the ground if equipped.

Items to check

- Walk around inspection
- Check engine oil level
- Check transmission fluid level
- Check brake fluid level
- Check coolant level
- Clean grill, radiator screen (when used in a dusty place)
- Clean around exhaust pipe and muffler.
- Check intake sediment drain cap
- Check brake pedal and pads
- Check parking brake
- Check indicators, gauges and meters
- Check lights
- Check seat belt, ROPS, doors and side retentions.
- Check wheel tightening torque.
- Check joint boots
- Check tire wear
- Check tire inflation pressure
- Check backup beeper (if equipped)
- Refuel
(See DAILY CHECK on page 62.)
- Care of safety labels
(See SAFETY LABELS on page 10.)

OPERATING THE ENGINE

⚠ WARNING

To avoid serious injury or death:

- Read and understand the safe operation section.
- Read and understand the safety labels located on the vehicle.
- To avoid the danger of exhaust fume poisoning, do not operate the engine in a closed building without proper ventilation.
- Never start engine while standing on ground. Start engine only from operator's seat.
- Make it a rule to set range gear shift lever to the "NEUTRAL" position before starting the engine.

Details regarding safe operation can be found in a different section.

(See SAFE OPERATION on page 5.)

IMPORTANT :

- Do not use starting fluid or ether.
- To protect the battery and the starter, make sure that the starter is not continuously turned for more than 10 seconds.

STARTING THE ENGINE

1. Make sure the cargo bed is lowered.
(See Raising and lowering the cargo bed on page 49.)
2. Make sure the parking brake is set.

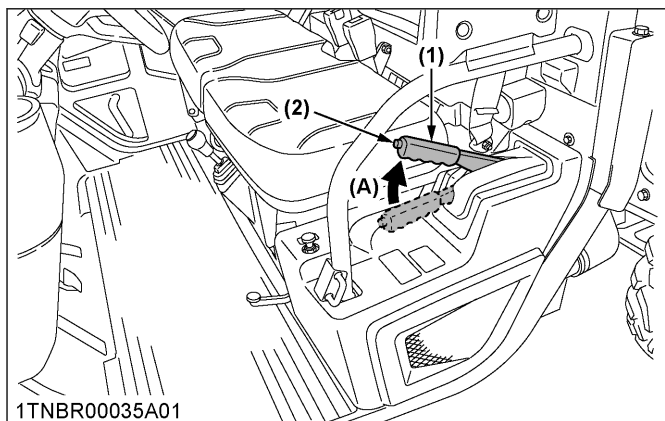

- (1) Parking brake lever (A) Pull to "PARK"
(2) Release button

3. Make sure the door is properly secured.
(See Locking and unlocking the door on page 33.)
4. Set the range gear shift lever to the "NEUTRAL" position.

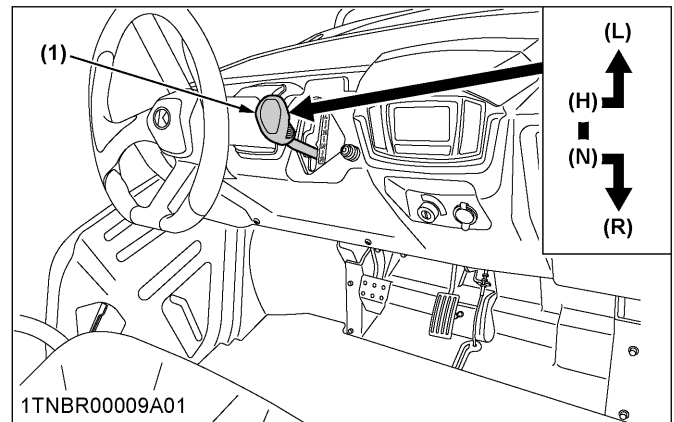

(1) Range gear shift lever

- (L) LOW range
(H) HIGH range
(N) "NEUTRAL" position
(R) "REVERSE"

5. Insert the key into the key switch and turn it "ON".

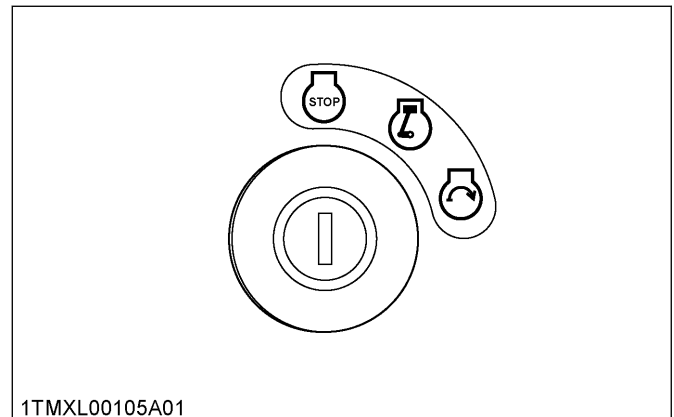

1TMXL00105A01

- ⏻ "OFF" (Engine-stop)
⏻ "ON" (Engine-run)
⏻ "START" (Engine-start)

IMPORTANT :

- ⏻ ON
All the accessories can be used while the engine is stopped.
Do not leave the key at "ON" position. The battery will be quickly discharged. Turn it back to the "OFF" position after use.

6. Check Easy Checker™ Lamps.

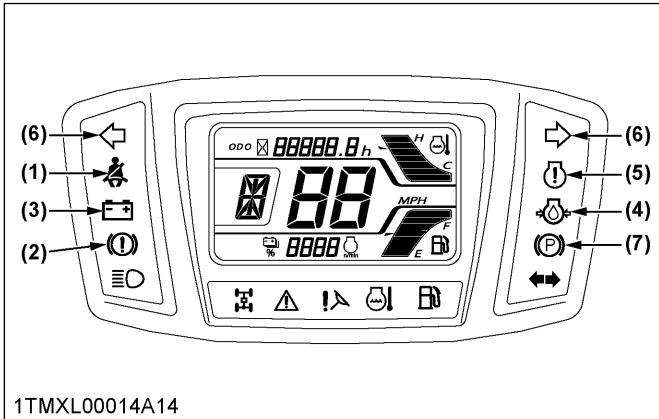

- | | |
|-------------------------|--|
| (1) Seat belt | (6) Hazard (if equipped)/Turn signal (if equipped) |
| (2) Brake fluid | (7) Parking brake |
| (3) Electrical charge | |
| (4) Engine oil pressure | |
| (5) Engine warning | |

- a. When the key is turned “ON”, lamps(3)(4)(5) should come on. If trouble should occur at any location while the engine is running, the warning lamp corresponding to that location comes on.
- b. The parking brake warning lamp(7) comes on while parking brake is applied and goes off when it is released.
If the parking brake is released but the lamp stays on, it means that the brake system may be damaged.
- c. With the key switch “ON”, when the operator or passenger does not fasten the seat belt, seat belt warning lamp(1) comes on.

IMPORTANT :

- **Daily checks with the Easy Checker™ only, are not sufficient. Never fail to conduct daily checks carefully by referring to the daily check.**
(See DAILY CHECK on page 62.)

NOTE :

- **For further details of Easy Checker™, see Easy Checker™ on page 38.**

7. Turn the key to “START” position and release when the engine starts.

IMPORTANT :

- **Because of safety devices, the engine will not start except when the range gear shift lever is placed in the “NEUTRAL” position.**

8. Check to see that all the warning lamps on the Easy Checker™ are “OFF”.
If any warning lamp stays on, immediately stop the engine and determine the cause.

1. Cold weather starting

When ambient temperature is below 0 °C (32 °F) and engine is cold, it may be difficult to start engine. Use the following starting procedure;

1. Turn the key to “START” position up to 10 seconds and release if the engine starts.

NOTE :

- **In cold condition, engine may not start in a few seconds at “START” position.**
2. If the engine fails to start after 10 seconds, turn the key to “OFF” position for 15 seconds. Do step 1 repeatedly up to 3 times until the engine starts.

- If it is still hard to start the engine, depress the speed control pedal by approximately 1/4 way down after hearing the sound of engine combustion while holding the key in "START" position.

IMPORTANT :

- To protect the battery and the starter, do not turn for more than 10 seconds and wait for 15 seconds between each attempt.

NOTE :**Engine oil:**

- Use fresh engine oil suitable for ambient temperature.
- Oil viscosity and classification affects cold weather starting. If the engine does not start when using recommended oil, try lower viscosity or higher classification oil.

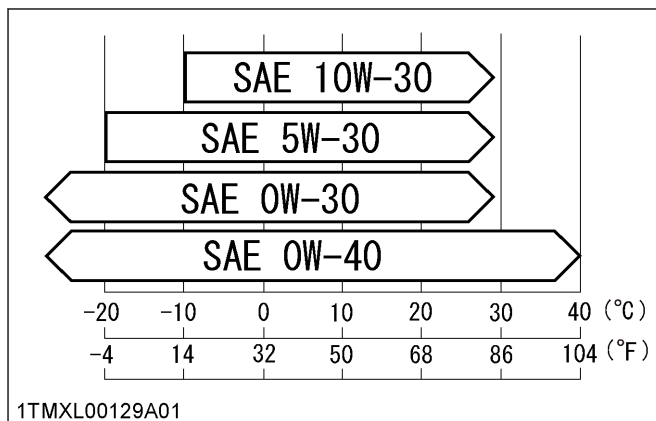

- Oil used in the engine should have an American Petroleum Institute (API) service classification and proper SAE engine oil according to the ambient temperatures as shown above.

See LUBRICANTS, FUEL AND COOLANT on page 58.

Fuel:

- Use fresh gasoline.
- Gasohol (up to 10 % ethyl alcohol, 90 % unleaded gasoline by volume) is approved for the engine. Other gasoline/ alcohol blends are not approved.

STOPPING THE ENGINE

- Park the vehicle on a firm, flat and level surface.
- After slowing the engine to idle, place the range gear shift lever in neutral and set the parking brake.
- Turn the key to "OFF".
- Remove the key.

WARMING UP THE ENGINE

⚠ WARNING

To avoid serious injury or death:

- Set the parking brake during warm-up.
- Set the range gear shift lever to the "NEUTRAL" position during warm-up.

IMPORTANT :

- Do not operate the vehicle under full load condition until it is sufficiently warmed up.

- For 5 to 10 minutes after engine start-up, allow engine to warm up without applying any load. This is to allow oil to reach every part of the engine. If load should be applied to the engine without this warm-up period, problems may develop such as seizure, breakage or premature wear may develop.
- Until warming up is completed, only 2 lower segments on the coolant temperature gauge are lighted.

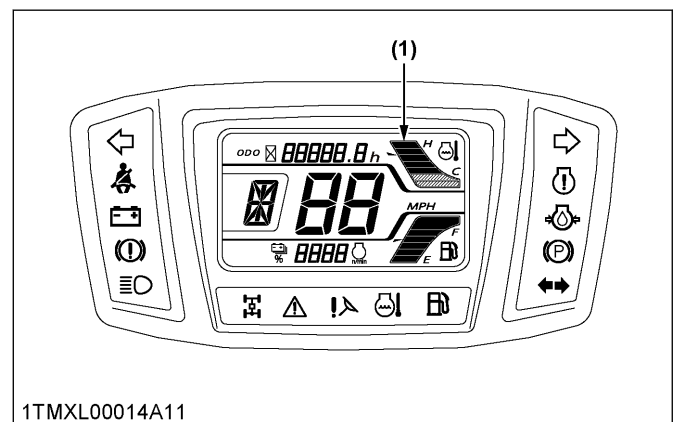

(1) Coolant temperature gauge

- In order to warm up the CVT belt, operate below 30 MPH (Hi gear) or 20 MPH (Low gear) for 1 mile. When the temperature is below freezing, operate for 5 miles.

JUMP STARTING

⚠ WARNING

To avoid serious injury or death:

- Battery gases can explode. Keep cigarettes, sparks, and flames away from battery.
- If vehicle battery is frozen, do not jump start engine.
- Do not connect other end of negative jumper cable to negative terminal of vehicle battery.
- The parts such as the muffler may be hot. Be careful not to get burned in connecting jumper cables.

When jump starting the engine, follow the instructions below to safely start the engine.

1. Bring helper vehicle with a battery of the same voltage as the disabled vehicle within easy cable reach.

IMPORTANT :

- **The vehicles must not touch.**

2. Engage the parking brake of both vehicles and put the shift lever in neutral. Shut the engine off.
3. Wear safety goggles and rubber gloves.
4. Ensure the vent caps are securely in place. (if equipped)
5. Attach the red clamp to the positive (red, (+) or pos.) terminal of the dead battery and clamp the other end of the same cable to the positive (red, (+) or pos.) terminal of the helper battery.
6. Clamp the other cable to the negative (black, (-) or neg.) terminal of the helper battery.
7. Clamp the other end to the engine block or frame of the disabled vehicle as far from the dead battery as possible.
8. Start the helper vehicle and let its engine run for a few moments. Start the disabled vehicle.
9. Disconnect the jumper cables in the exact reverse order of attachment. (Steps 7, 6 and 5).

Connect cables in numerical order.
Disconnect in reverse order after use.

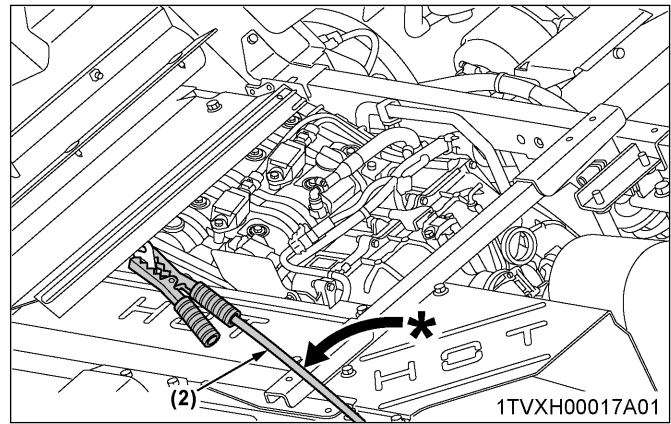
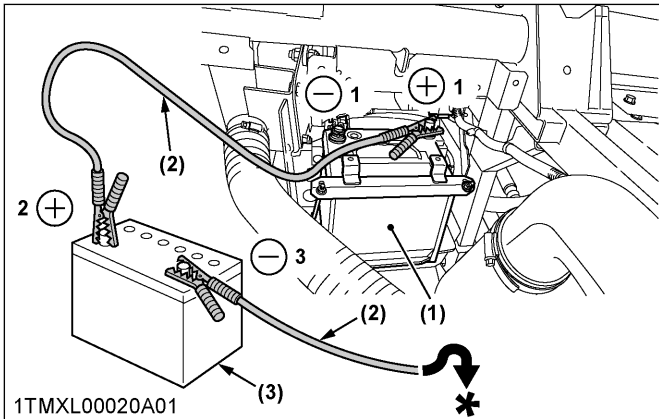

- (1) Dead battery
- (2) Jumper cables
- (3) Helper battery

IMPORTANT :

- **This vehicle has a 12 volt negative (-) ground starting system.**
 - **Use only same voltage for jump starting.**
 - **Use of a higher voltage source could result in severe damage to vehicle's electrical system.**
- Use only matching voltage source when "Jump starting" a low or dead battery.

STARTING WHEN THE ENGINE IS FLOODED

WARNING

To avoid serious injury or death:

- Set the parking brake.
- Set the range gear shift lever to the "NEUTRAL" position during this procedure.

IMPORTANT :

- **When the plug is wet with gasoline, you cannot start the engine.**

1. Make sure the cargo bed is lowered.
2. Make sure the parking brake is set.

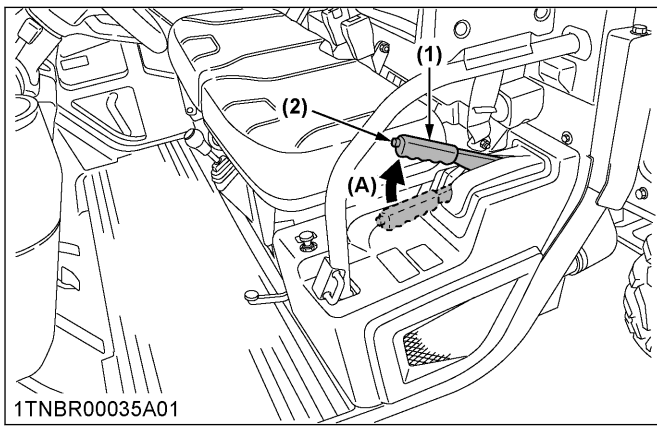

1TNBR00035A01
 (1) Parking brake lever (A) Pull to "PARK"
 (2) Release button

3. Make sure the door is properly secured.
 (See Locking and unlocking the door on page 33.)
4. Set the range gear shift lever to the "NEUTRAL" position.

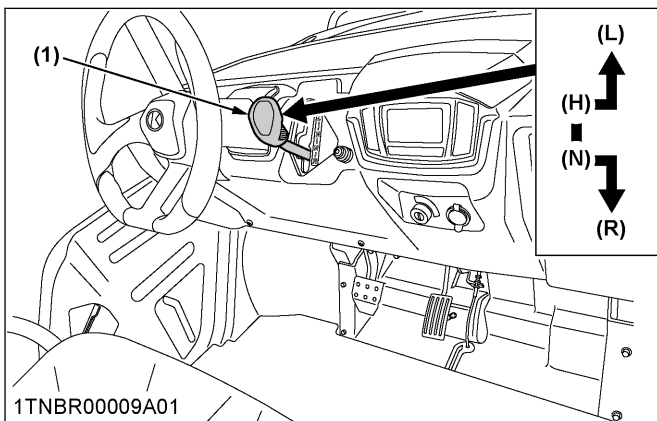

1TNBR00009A01
 (1) Range gear shift lever (L) LOW range
 (H) HIGH range
 (N) "NEUTRAL" position
 (R) "REVERSE"

5. Depress the speed control pedal to the stopper bolt and keep this.
6. Insert the key into the key switch and turn it "ON".

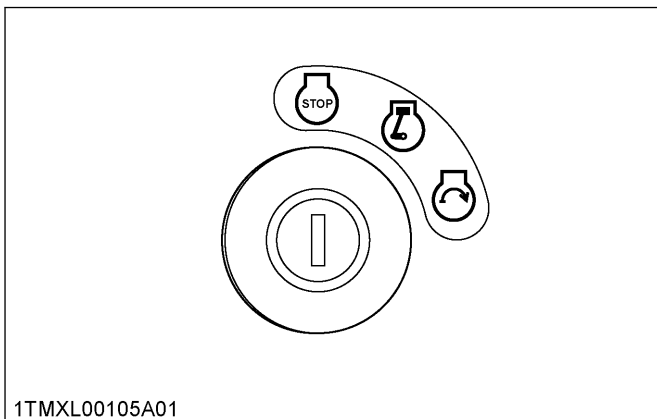

1TMXL00105A01
 (STOP) "OFF" (Engine-stop)
 (ON) "ON" (Engine-run)
 (START) "START" (Engine-start)

IMPORTANT :

- ON
 All the accessories can be used while the engine is stopped.
 Do not leave the key at "ON" position. The battery will be quickly discharged. Turn it back to the "OFF" position after use.

7. Check Easy Checker™ Lamps.
 See the following description.
8. Turn the key to "START" position up to 10 seconds and release keeping depressing the speed control pedal to the stopper bolt.

IMPORTANT :

- To protect the battery and the starter, make sure not to turn for more than 10 seconds and wait for 15 seconds between each operation.

9. Check to see that all the warning lamps on the Easy Checker™ are "OFF".
 If any warning lamp stays on, immediately stop the engine and determine the cause.
10. Try to start the engine without depressing the speed control pedal after repeating this procedure 2 or 3 times.

NOTE :

- If the engine does not start this way, try other methods in TROUBLESHOOTING on page 94.

Easy Checker™ Lamps

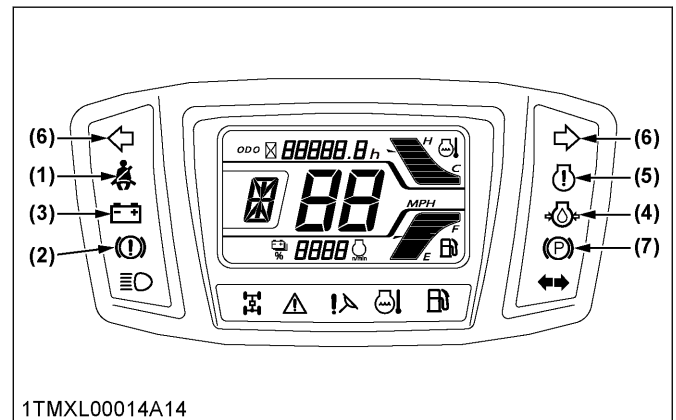

1TMXL00014A14
 (1) Seat belt (6) Hazard (if equipped)/Turn signal (if equipped)
 (2) Brake fluid (7) Parking brake
 (3) Electrical charge
 (4) Engine oil pressure
 (5) Engine warning

- a. When the key is turned "ON", lamps(3)(4)(5) should come on. If trouble should occur at any location while the engine is running, the warning lamp corresponding to that location comes on.

- b. The parking brake warning lamp(7) comes on while parking brake is applied and goes off when it is released.
If the parking brake is released but the lamp stays on, it means that the brake system may be damaged.
- c. With the key switch "ON", when the operator or passenger does not fasten the seat belt, seat belt warning lamp(1) comes on.

IMPORTANT :

- **Daily checks with the Easy Checker™ only, are not sufficient. Never fail to conduct daily checks carefully by referring to the daily check.**
(See DAILY CHECK on page 62.)

NOTE :

- **For further details of Easy Checker™, see Easy Checker™ on page 38.**

OPERATING THE VEHICLE

OPERATING NEW VEHICLE

How a new vehicle is handled and maintained determines the life of the vehicle.

A new vehicle just off the factory production line has been tested, but the various parts are not accustomed to each other, so care should be taken to operate the vehicle for the first 50 hours at a slower speed and avoid excessive work or operation until the various parts become “*broken-in*”.

The manner in which the vehicle is handled during the “*breaking-in*” period greatly affects the life of your vehicle. Therefore, to obtain the maximum performance and the longest life of the vehicle, it is very important to properly break-in your vehicle.

In handling a new vehicle, the following precautions should be observed.

1. Do not operate the vehicle at full speed for the first 50 hours

- Do not start quickly nor apply the brakes suddenly.
- In winter, operate the vehicle after fully warming up the engine.
- Do not run the engine at speeds faster than necessary.
- On rough roads, slow down to suitable speeds.
Do not operate the vehicle at fast speed. The above precautions are not limited only to new vehicles, but to all vehicles. But it should be especially observed in the case of new vehicles.

2. Changing lubricating oil for new vehicles

The lubricating oil is especially important in the case of a new vehicle. The various parts are not “*broken-in*” and are not accustomed to each other. Small pieces of metal grit may develop during the operation of the vehicle; and this may wear out or damage the parts. Therefore, care should be taken to change the lubricating oil a little earlier than would ordinarily be required.

For further details of change interval hours, see MAINTENANCE on page 55.

STARTING THE VEHICLE



WARNING

To avoid serious injury or death:

- Read and understand the safe operation section.
- Read and understand the safety labels located on the vehicle.
- To avoid the danger of exhaust fume poisoning, do not operate the engine in a closed building without proper ventilation.
- Never start engine while standing on ground. Start engine only from operator's seat.
- Make it a rule to set range gear shift lever to the “**NEUTRAL**” position before starting the engine.

1. Make sure the door is properly secured.
 - Locking and unlocking the door on page 33
2. Fasten the seat belt.
 - Seat belt on page 34
3. Adjust steering position.
 - Tilt steering wheel (if equipped) on page 34
4. Start the engine.
 - OPERATING THE ENGINE on page 27
5. Selecting light switch position.
 - Head light switch on page 34
 - Horn button on page 35
6. Checking the brake pedal.
 - Brake pedal on page 36
7. Selecting the travel speed.
 - Range gear shift lever on page 36
 - 4WD lever on page 37
 - Parking brake lever on page 37
 - Speed control pedal on page 37

1. Locking and unlocking the door



WARNING

To avoid serious injury or death:

- Secure the doors properly.

Secure the door properly to lock. Pull up the door handle to unlock.

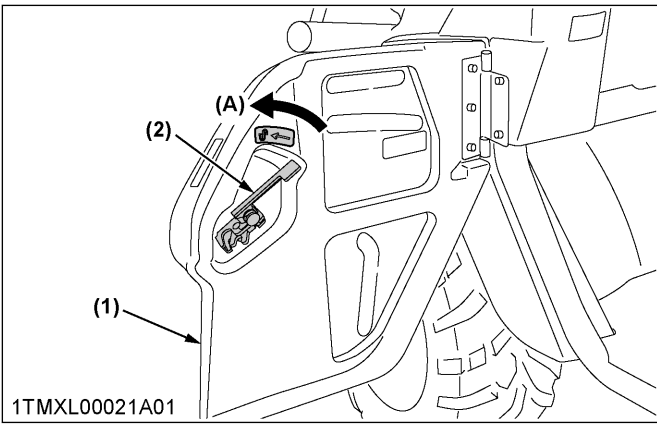

1TMXL00021A01

- (1) Door
- (2) Door handle

(A) "UNLOCK"

2. Seat belt

WARNING

To avoid serious injury or death:

- Always wear your seat belts. Seat belts reduce the potential for injury.
- Always use the seat belts when operating and riding in the vehicle.
- Passenger must be able to grasp the handhold with seat belt on and both feet on floor.

Always wear your seat belt. Make sure the seat belt warning lamp is off.

NOTE :

- When the operator's seat belt is not engaged, vehicle speed is limited to 15 mph.

Adjust the seat belts for proper fit and connect the buckle.

Seat belt is an emergency locking retractable type.

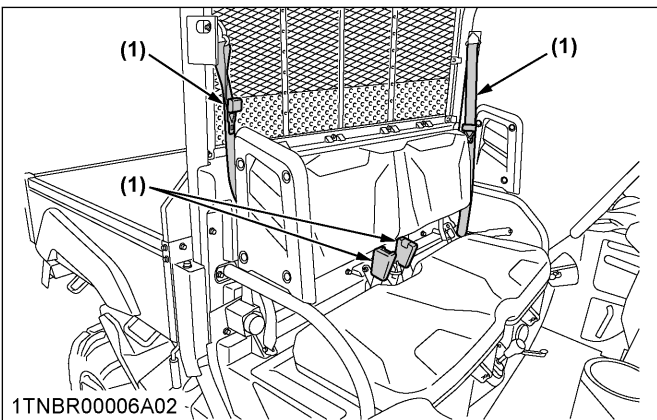

1TNBR00006A02

- (1) Seat belt

3. Tilt steering wheel (if equipped)

Adjust the steering wheel to proper position. The steering wheel can be adjusted while the tilt lever is pulled.

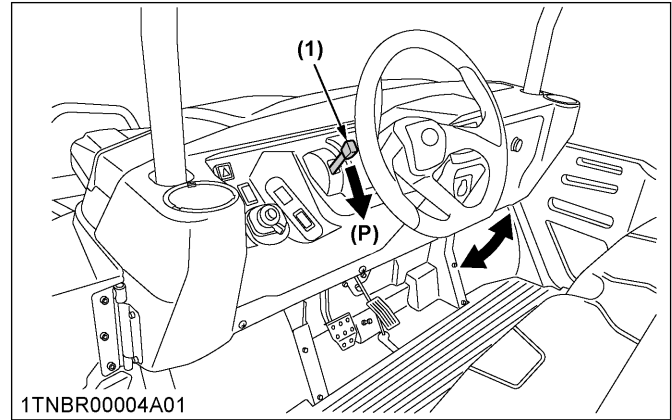

1TNBR00004A01

- (1) Tilt lever

(P) "PULL"

4. Head light switch

The head light switch is operative when the key switch is in the "ON" position.

Turn on the key switch and turn the head light switch clockwise, the following head lights light up on the switch.

Turn the head light switch counterclockwise to the "OFF" position to turn off the head light.

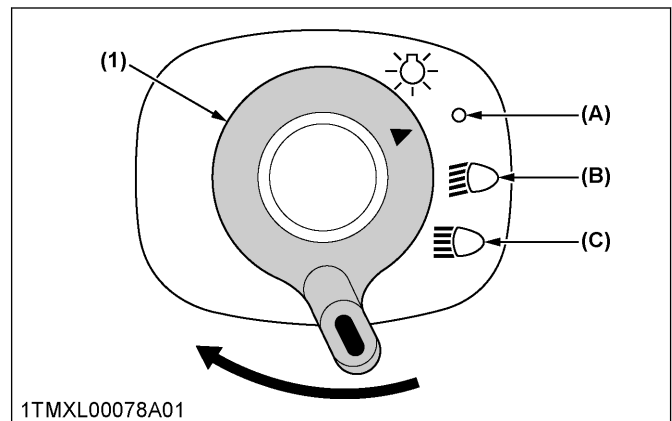

1TMXL00078A01

- (1) Head light switch

(A) Head lights "OFF"

(B) Head lights low beam "ON"

(C) Head lights high beam "ON"

NOTE :

- Turning the head light switch to the "ON" position causes the following lamps to light simultaneously.
 - Tail lights (lamps at the rear portions of the vehicle)

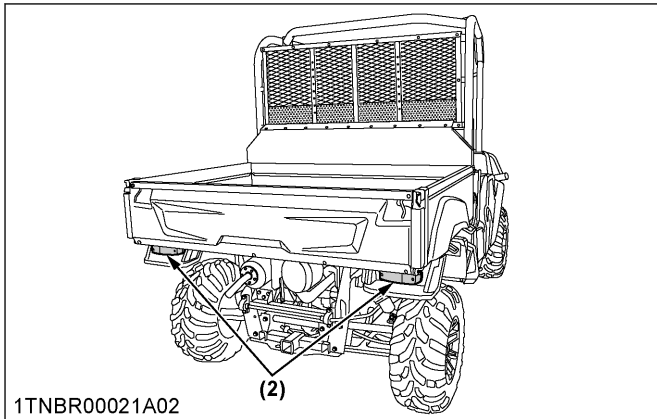
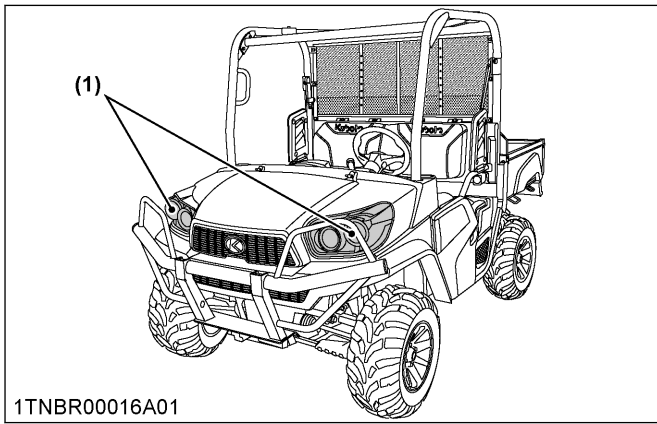

(1) Head light
(2) Tail lamp (combination lamp)

5. Hazard light switch (if equipped)

Press the hazard light switch, the hazard light flash along with the indicator on the instrument panel. Press the hazard light switch again to turn off the hazard light.

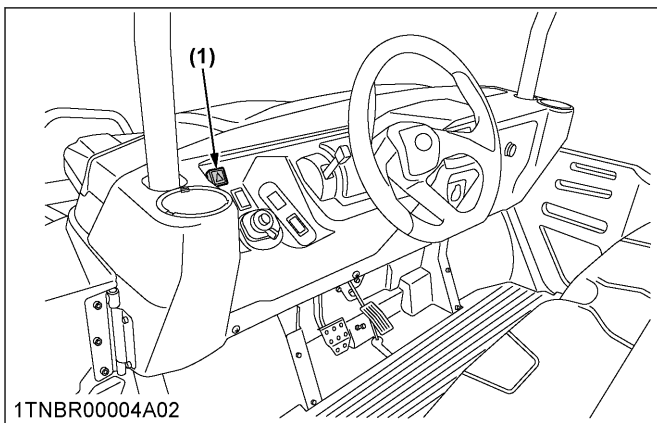

(1) Hazard light switch

NOTE :

- The hazard light switch is operative when the key switch is in either the "ON" or "OFF" position. Leaving the switch "ON" causes the battery to drain.

6. Turn signal light switch (if equipped)

To indicate a right turn, turn the turn signal light switch clockwise.

To indicate a left turn, turn the turn signal light switch counter-clockwise.

When the left or right signal is activated, the indicated turning light will flash and the other will stay on.

The indicator lamp on the instrument panel also flashes like the above.

NOTE :

- The turn signal light switch is only operative when the key switch is in the "ON" position.
- If the hazard light switch is pressed to the "ON" position while the turn signal is activated, the indicated turning light will flash and the other will stay on.
- Return switch to center position after turning.

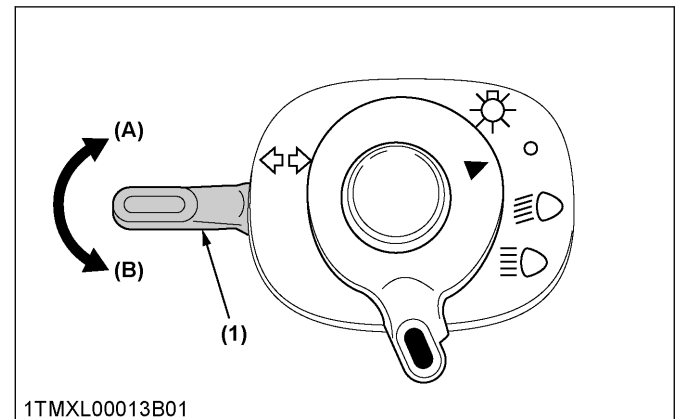

(1) Turn signal light switch
(A) "RIGHT TURN"
(B) "LEFT TURN"

7. Horn button

The horn switch is operative when the key switch is in either the "ON" or "OFF" position.

The horn will sound when the horn button is pressed.

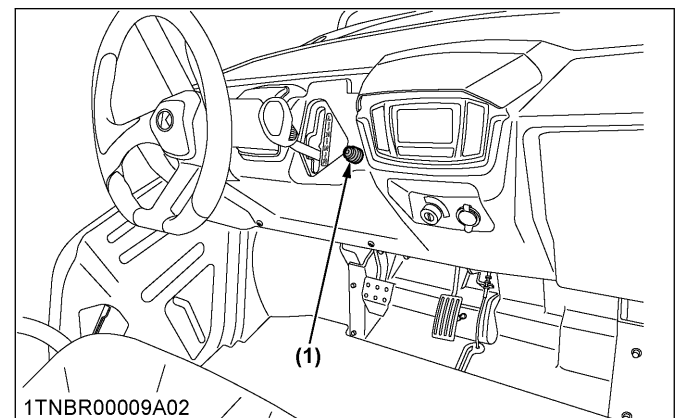

(1) Horn button

8. Brake pedal

WARNING

To avoid serious injury or death:

- If the operator suddenly brakes, an accident may occur due to loss of control or the shifting forward of heavy loads.
- When driving on icy, wet or loose surface, operate at reduced speed to avoid skidding and loss of steering control.

The brake pedal is the left pedal on the foot board. Depress the pedal to slow or stop the vehicle.

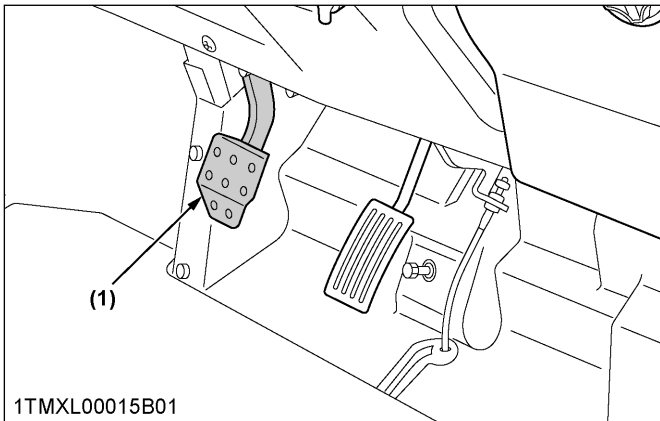

(1) Brake pedal

9. Range gear shift lever

WARNING

To avoid serious injury or death:

- Avoid changing range gear shift lever when ascending or descending a slope.
- Before ascending or descending a slope, shift to the [L] range to control the vehicle speed.
- If you shift gears while ascending or descending a slope, be prepared to use the brake to maintain control.
- Operate in reverse at slow speeds to maintain control.
- Do not shift erratically.
- Improper range gear shift lever position will cause the vehicle to momentarily coast on slopes.

IMPORTANT :

- Shift the range gear shift lever (L-H-N-R) or 4WD lever only when the vehicle is completely stopped.
- Shift the range gear shift lever only when the engine is at low idle.

Range gear shift position display

The range gear shift position is displayed on the LCD panel.

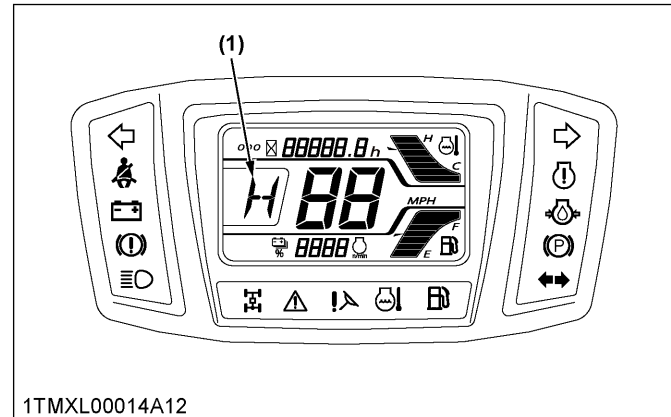

(1) Range gear shift position

1. The range gear shift lever can only be shifted when vehicle is completely stopped and the speed control pedal is in the "NEUTRAL" position.
2. To avoid transmission and shift linkage damage, completely stop the vehicle using the brake pedal before shifting gears.
3. Select proper gear and engine speed depending on the type of job.
Always shift into low gear for any of the following conditions.
 - Operating in rough terrain or over obstacles
 - Loading the vehicle onto a trailer
 - Towing heavy loads
 - Driving frequently at low RPM or at ground speeds below 10 MPH (16 km/h)
4. Before dismounting vehicle, shift the range gear shift lever to the "NEUTRAL" position and set parking brake.

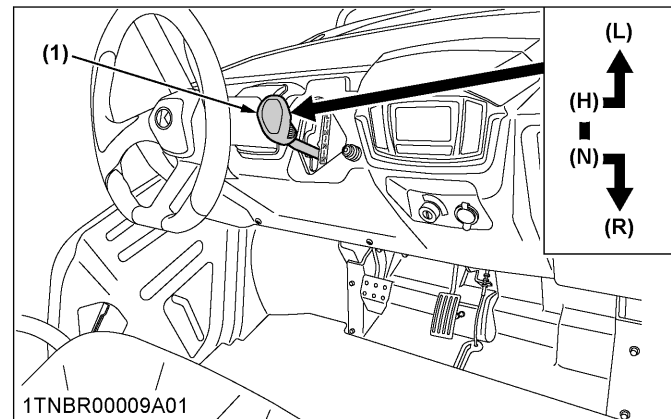

(1) Range gear shift lever

- (L) LOW range
- (H) HIGH range
- (N) "NEUTRAL" position
- (R) "REVERSE"

10. 4WD lever

⚠ WARNING

To avoid serious injury or death:

- Do not engage the front wheel drive when traveling at road speed.
- When driving on icy, wet or loose surfaces, make sure the vehicle is correctly ballasted to avoid skidding and loss of steering control.
- An accident may occur if the vehicle is suddenly braked, such as by heavy towed loads shifting forward causing loss of control.
- The braking characteristics are different between 2 and 4 wheel drive. Be aware of the difference and use carefully.

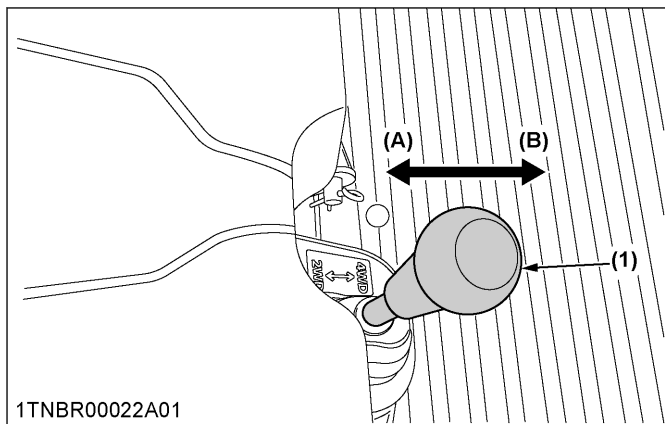

1TNBR00022A01

(1) 4WD lever

(A) "2WD"
(B) "4WD"

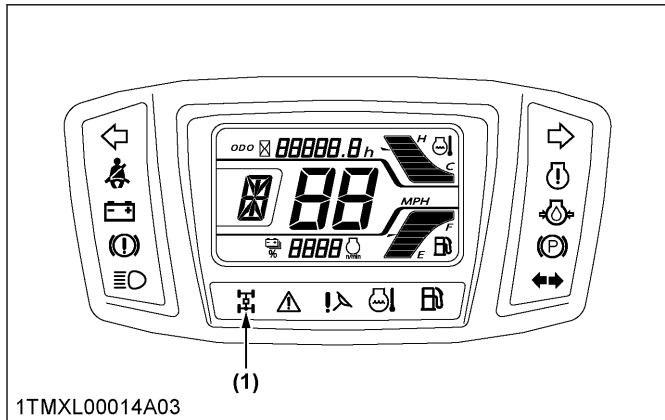

1TMXL00014A03

(1) 4WD indicator

IMPORTANT :

- Use the lever to engage the front wheels with the vehicle stopped. Shift the lever to "4WD" to engage the front wheel drive. When the lever is in "4WD" position, the 4WD indicator comes on.
- Tires will wear quickly if front wheel drive is engaged on paved roads.

Front wheel drive is effective for the following jobs:

- When greater pulling force is needed, such as working in a wet field, when pulling a trailer, or when working with a front-end blade.
- When working in sandy soil.

11. Parking brake lever

To release the parking brake, depress the brake pedal, push release button and push down parking brake lever.

Depressing the brake pedal makes release force smaller. Make sure that indicator in the Easy Checker™ goes off.

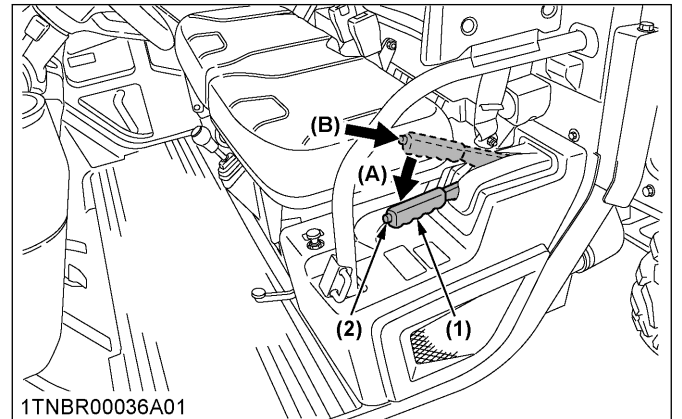

1TNBR00036A01

(1) Parking brake lever
(2) Release button

(A) "RELEASE"
(B) "PUSH"

12. Speed control pedal

Use the speed control pedal when traveling. Push down on it for higher speed.

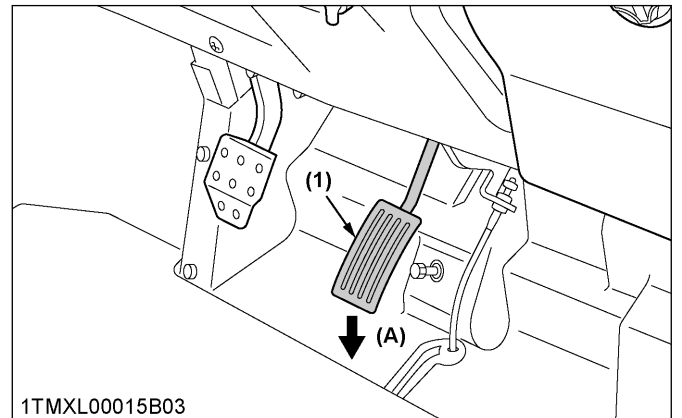

1TMXL00015B03

(1) Speed control pedal

(A) "INCREASE"

13. Electric power steering

1. Power steering is activated while the key is "ON" position. While the power steering is not activated, the manner of steering is manual steering.

- Avoid keeping the steering wheel turned to the steering locks. If the power steering starts to overheat, the ECU may limit the steering assistance until the system cools down.
- Avoid turning the steering wheel repeatedly while the vehicle is stopped. This can cause premature wear on the tires, and if the power steering starts to overheat, the ECU may limit the steering assistance until the system cools down.

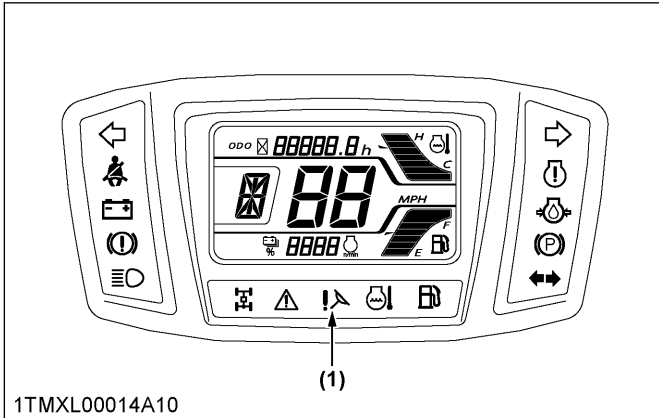

(1) Electric power steering

STOPPING THE VEHICLE

WARNING

To avoid serious injury or death:
When leaving the vehicle.

- Park the vehicle on firm and level ground.
- Set the parking brake.
- Lower the implement to the ground (if equipped).
- Stop the engine and remove the key.

- Release the speed control pedal.
- Step on the brake pedal.
- After the vehicle has stopped, put the range gear shift lever in neutral, and set the parking brake.

CHECK DURING DRIVING

IMPORTANT :

Immediately stop the engine if:

- The engine suddenly slows down or accelerates.
- Unusual noises suddenly occur.
- Exhaust fumes suddenly become very dark.

While driving, check the following items to see that all the parts are functioning normally:

- Easy Checker™ on page 38
- Fuel gauge on page 39
- Coolant temperature gauge on page 39
- Hourmeter, odometer and error code on page 39

- Speedometer on page 40
- Tachometer on page 40

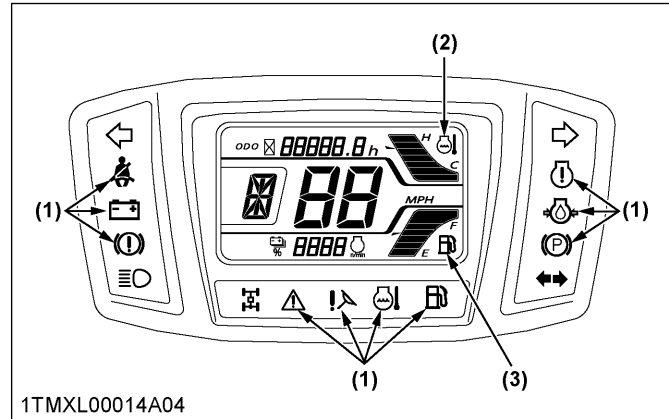

- (1) Easy Checker™
- (2) Coolant temperature gauge
- (3) Fuel gauge

1. Easy Checker™

If the warning lamps in the Easy Checker™ come on during operation, immediately stop the engine, and find the cause as shown as follows.

Never operate the vehicle with an Easy Checker™ lamp on.

Engine oil pressure

If the oil pressure in the engine goes below the prescribed level, the warning lamp in the Easy Checker™ will come on.

If this should happen during operation, and it does not go off when the engine is accelerated, check level of engine oil.

(See Checking engine oil level on page 64.)

Electrical charge

If the alternator is not charging the battery, the Easy Checker™ will come on.

If this should happen during operation, check the electrical charging system or consult your local KUBOTA Dealer.

Low brake fluid level

If the brake fluid goes below the prescribed level, the warning lamp in the Easy Checker™ will come on.

If this should happen during operation, check to see that there is no oil leak in the brake system, and then add DOT3 brake fluid.

(See Checking brake fluid level on page 66.)

Parking brake

If the parking brake indicator is on during operation, release the parking brake lever immediately. The parking brake indicator in the Easy Checker™ comes on if the parking brake is applied.

Seat belt

With the key switch "ON", when the operator or passenger does not fasten the seat belt, seat belt warning lamp comes on.

Electric power steering

If the electric power steering system has an error during operation, the indicator will come on. If the indicator comes on, consult your local KUBOTA Dealer.

Master caution light

The flashing of the master caution light is a sign of malfunction of the system. If the flashing is not corrected by restarting the machine, consult your local KUBOTA Dealer.

Engine warning

The lamp comes up while the a error code is displayed.
(See Hourmeter, odometer and error code on page 39.)

2. Fuel gauge

Park the vehicle on a flat place.

When the key switch is "ON", the fuel gauge indicates the fuel level.

Be careful not to empty the fuel tank. Otherwise air may enter the fuel system.

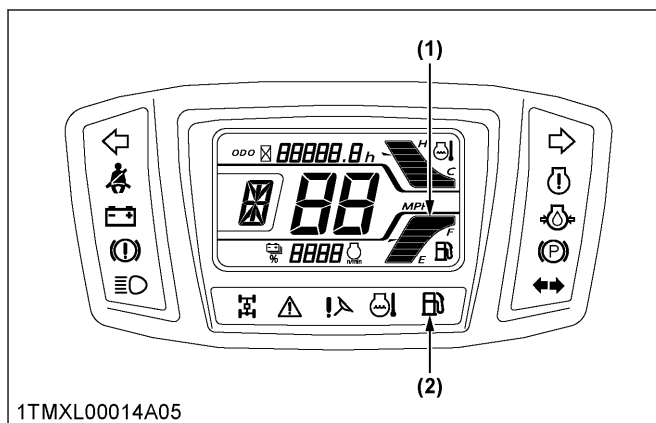

1TMXL00014A05

- (1) Fuel gauge
(2) Fuel level warning lamp

3. Coolant temperature gauge**WARNING**

To avoid serious injury or death:

- Do not remove radiator cap until coolant and engine temperature has cooled. Then loosen cap slightly to the stop to relieve any pressure before removing cap completely.

- With the key switch "ON" the coolant temperature gauge indicates the temperature of the coolant.
- If the engine is overheated, the warning lamp will come on and the buzzer will sound. (See TROUBLESHOOTING on page 94 to check the vehicle.)

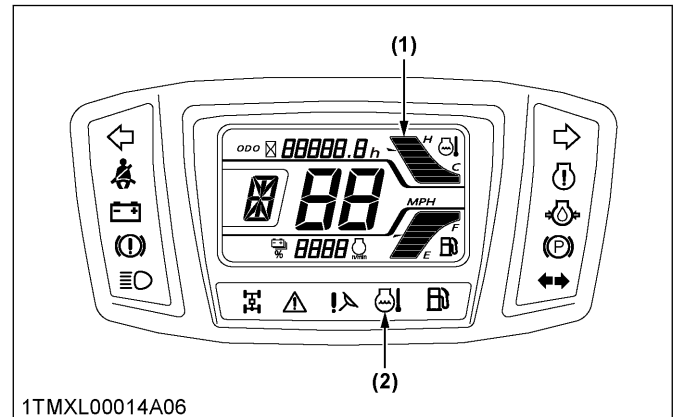

1TMXL00014A06

- (1) Coolant temperature gauge
(2) Overheat warning lamp

NOTE :

- If the engine overheat occur, do not stop the engine. When it is safe to do so, remove the engine load and keep the engine idling to allow cool down to occur. After the warning lamps go off, wait for 5 minutes, and stop the engine. See TROUBLESHOOTING on page 94.

4. Hourmeter, odometer and error code**Hourmeter**

When the key is turned to the "ON" position and the engine is not running, the hourmeter is displayed.

The hourmeter indicates in 5 digits the hours the vehicle has been used; the last digit indicates 1/10 of an hour.

Odometer

When the key is the "ON" position and the engine is running, the odometer is displayed.

The odometer indicates in 5 digits the distance the vehicle has been used; the last digit indicates 1/10 of a mile.

Error code

In the event that an error code is displayed instead of the hourmeter or the odometer, note the error code and turn off the engine. Restart the engine. If an error code is displayed again, consult your KUBOTA Dealer.

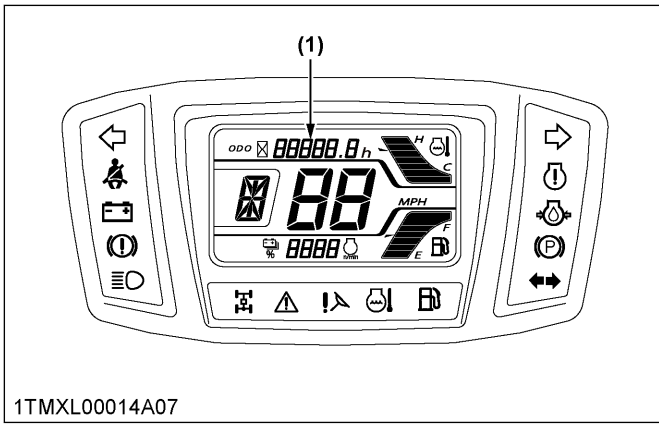

1TMXL00014A07

(1) Hourmeter, odometer

5. Speedometer

The speedometer indicates the traveling speed.

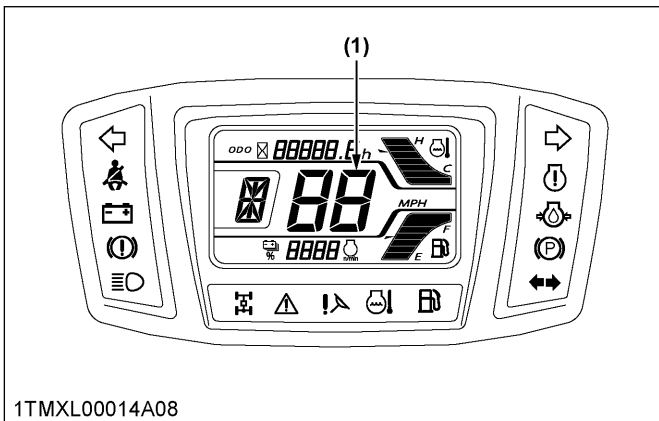

1TMXL00014A08

(1) Speedometer

6. Tachometer

The tachometer indicates the engine speed.

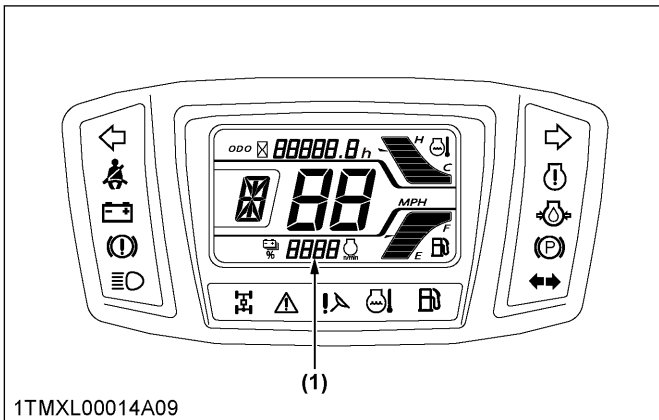

1TMXL00014A09

(1) Tachometer

PARKING THE VEHICLE

1. Parking brake lever

The parking brake lever is designed for use not only in parking but also in emergency stops (in the event that the foot brake malfunctions).

! WARNING

To avoid serious injury or death:
Before dismounting vehicle

- Always set parking brake and lower all implements to the ground.
- Leaving transmission in gear with the engine stopped will not prevent vehicle from rolling.
- Do not park the vehicle over litter or weeds or bushes.
- Do not park the vehicle near flammable material.
- When parking the vehicle inside a garage, ensure proper air circulation.
- Stop the engine and remove the key.

1. Stop the vehicle on a level surface.
2. To set the parking brake, depress the brake pedal and pull the parking brake lever to park.
3. To release the parking brake, depress the brake pedal, push the release button and push down the parking brake lever. When the parking brake is released, the brake indicator in the Easy Checker™ goes off.

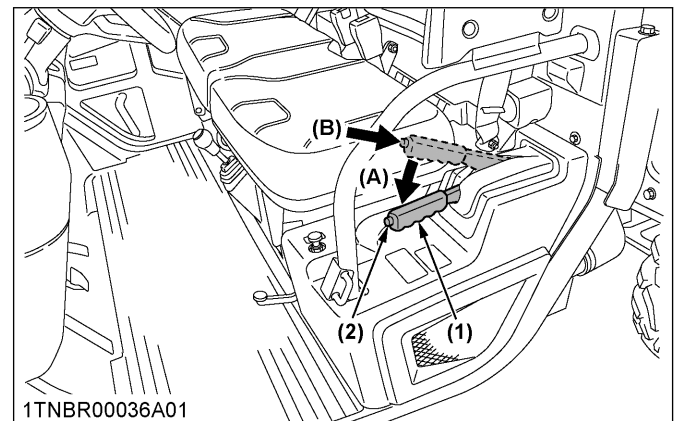

1TNBR00036A01

- | | |
|-------------------------|---------------|
| (1) Parking brake lever | (A) "RELEASE" |
| (2) Release button | (B) "PUSH" |

IMPORTANT :

- If the vehicle is operated with the parking brake applied, the brake will be damaged.

ACCESSORY

1. 12 V electric outlet

1.1 Electric outlet

- The 12 volt power point is located on the front-panel. An auxiliary light or other devices may be connected to this outlet.
- This outlet is powered when the key switch is in the "ON" position.
Remove accessory when not in use to avoid battery drain down.
- Do not connect a light or other device that draws more than 120 watts to this power point, or the battery may discharge very rapidly or the outlet may fail.

IMPORTANT :

- **Do not use as a cigarette lighter.**
- **Do not use when wet.**
- **Make sure that the cap is closed when the outlet is not used.**

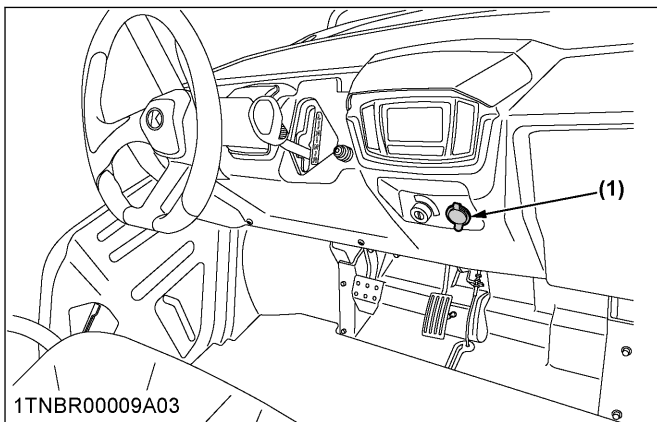

(1) 12 V electric outlet (maximum 120 W)

1.2 Auxiliary power supply for relay coil 1

The 12 volt power point is located under the hood.

1. Open the hood.
2. Remove the blue tape when using, and wrap the tape back after use.

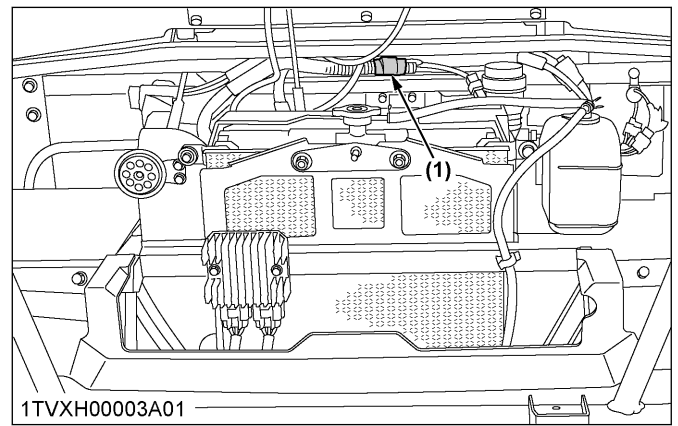

(1) Auxiliary power supply for relay coil 1 (maximum 12 W)

1.3 Auxiliary power supply for relay coil 2

The 12 volt power point is located on the right under the cargo bed.

1. Lift up the cargo bed.
2. Remove the blue tape when using, and wrap the tape back after use.

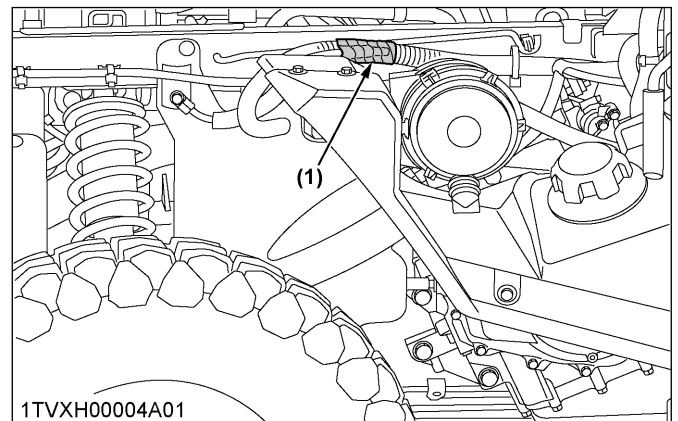

(1) Auxiliary power supply for relay coil 2 (maximum 12 W)

1.4 Auxiliary power supply for relay coil 3

The 12 volt power point is located under the driver's seat.

1. Remove the 2 plastic bolts and the cover.

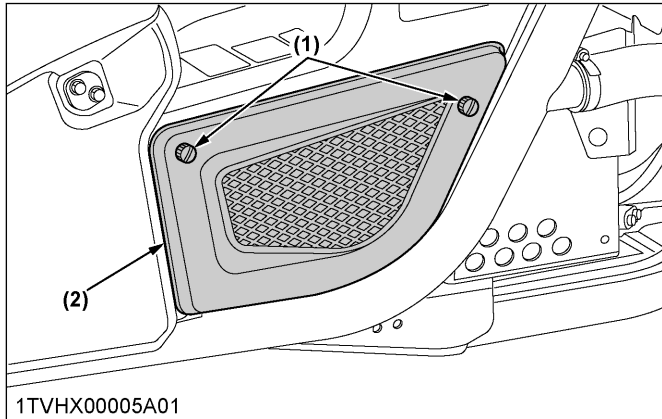

- (1) Plastic bolt
- (2) Cover

2. Remove the blue tape when using, and wrap the tape back after use.

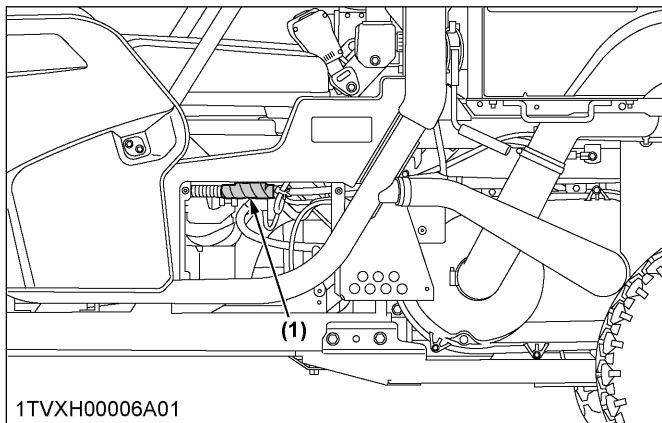

- (1) Auxiliary power supply for relay coil 3 (maximum 12 W)

2. Utility box

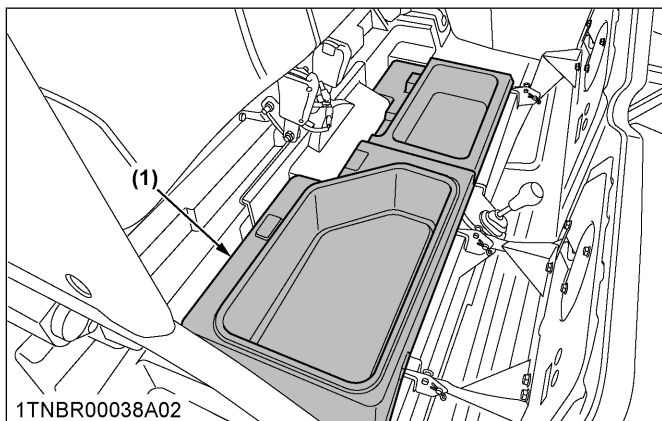

- (1) Utility box

3. Glove box and glove box cover (if equipped)

Insert the key into the key slot and turn it counterclockwise to lock.

Insert the key into the key slot and turn it clockwise to unlock.

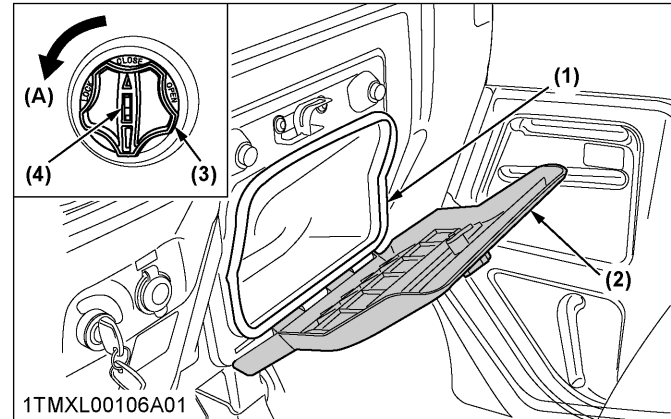

- (1) Glove box
- (2) Glove box cover (if equipped)
- (3) Knob (if equipped)
- (4) Key slot

(A) "LOCK"

OPERATING TECHNIQUES

1. Differential lock

! WARNING

To avoid serious injury or death due to loss of steering control:

- Do not operate the vehicle at high speed with differential lock engaged.
- Do not attempt to turn with the differential lock engaged.
- Release the differential lock before making a turn in field conditions.

IMPORTANT :

- When using the differential lock, always slow the vehicle and engine down.
- To prevent damage to powertrain, do not engage differential lock when one wheel is spinning and the other is completely stopped.

If one of the rear wheels should slip, step on the differential lock pedal. Both wheels will then turn together, reducing slippage.

Differential lock is maintained while the pedal is depressed or may be held by using differential lock holder.

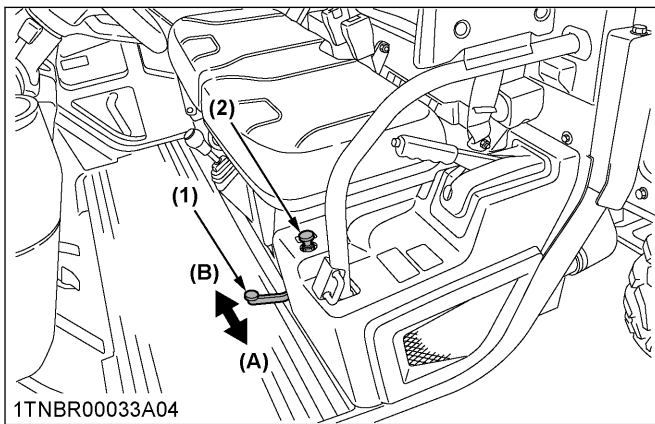

1TNBR00033A04

- (1) Differential lock pedal (A) Depress to "ENGAGE"
 (2) Differential lock holder (B) Release to "DISENGAGE"

Handling the retaining device for differential lock

1. Pull the differential lock holder up while the differential lock pedal is depressed.
2. Release the pedal before your hand leaves the differential lock holder.
The differential lock is then maintained even if your foot leaves the pedal.
3. The lock is released when the foot pedal is depressed again.

2. Driving on unfamiliar terrain

⚠️ WARNING

To avoid serious injury or death:

- Check for hidden obstacles or hazards before driving in a new area.
- Keep your speed down until you know the area well.
- Use existing trails and stay away from hazardous areas such as steep, rocky slopes or swamps.
- Be cautious when visibility is limited, as you may not be able to see obstacles in your path.

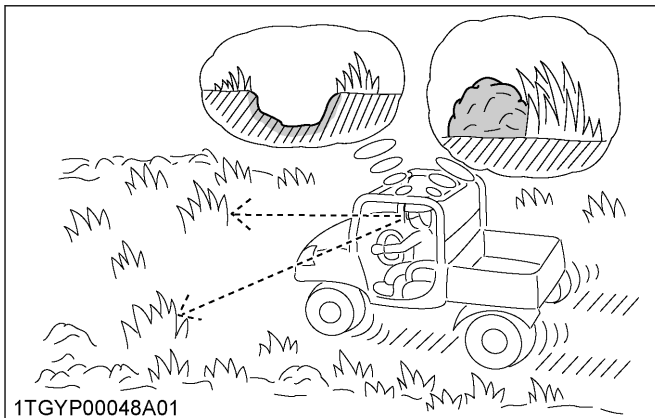

1TGYP00048A01

3. Driving in reverse

⚠️ WARNING

To avoid serious injury or death:

- Turn around, look down and behind you before backing up to be sure there are no obstacles or people in your way.
- Depress speed control pedal gradually and reverse cautiously.
- To stop while driving in reverse take your foot off the speed control pedal and gradually apply the brake.
- Do not suddenly engage the brake.

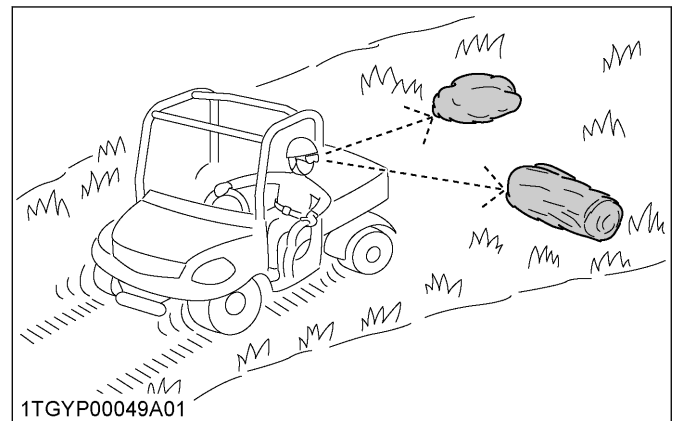

1TGYP00049A01

4. Driving in "4WD"

⚠️ WARNING

To avoid serious injury or death:

- Do not drive in "4WD" on paved surfaces.
- The steering characteristics are different between 2 and 4 wheel drive.

For the maximum traction, shift the range gear shift lever into low range and use "4WD" on steep slopes or when stuck in the mud, with differential locked if necessary.

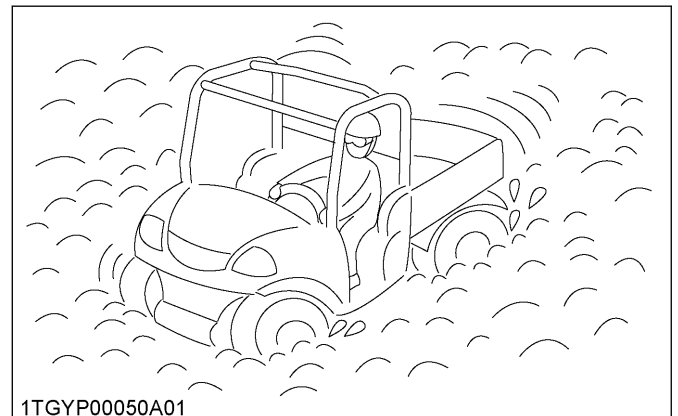

1TGYP00050A01

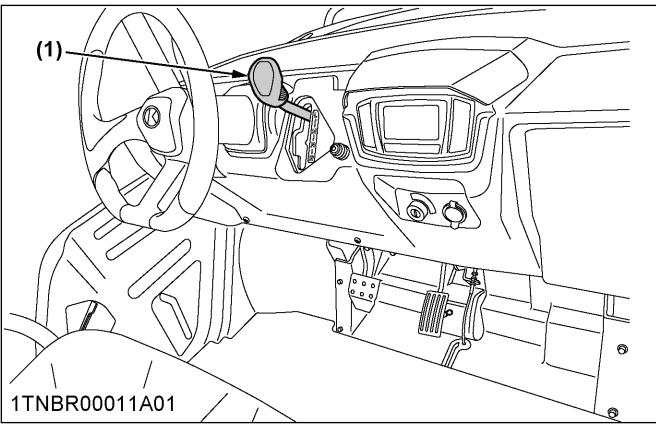

(1) LOW range

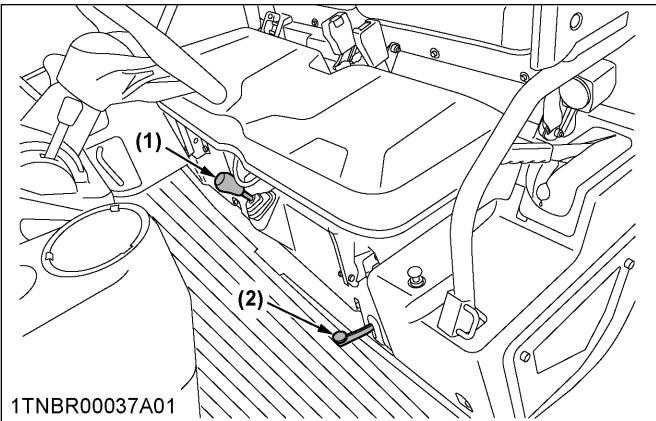

(1) "4WD"
(2) Differential lock "ON"

5. Turning the vehicle

WARNING

To avoid serious injury or death:

- Reduce vehicle speed before entering the turn and maintain an even speed through the turn.
- Do not make sharp turns in order to avoid loss of control or tipping.

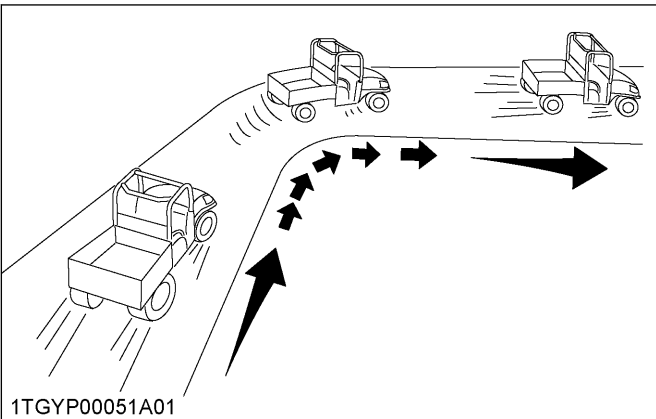

6. Driving on hills

WARNING

To avoid serious injury or death:

- Do not turn sideways on a hill, or the vehicle may roll over.
- Always go straight up or down the hill.
- Slow down until you can get a clean view of the other side at the crest of a hill.
- If the engine stalls on a steep slope, roll slowly straight down, using the brake.
- Stop and look for obstacles before descending a hill.

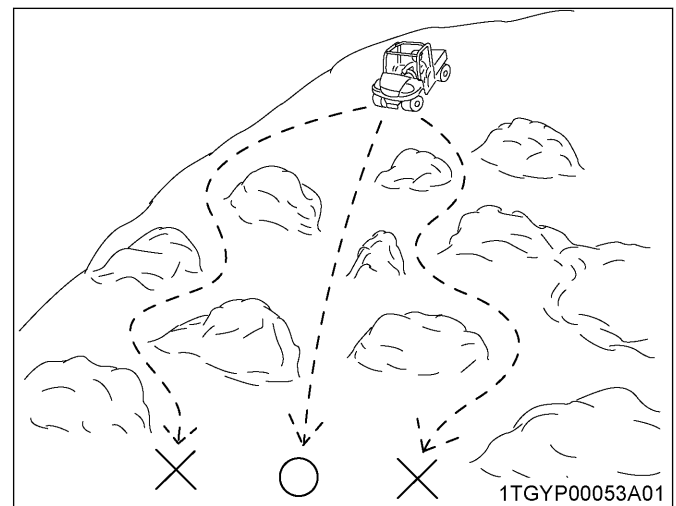
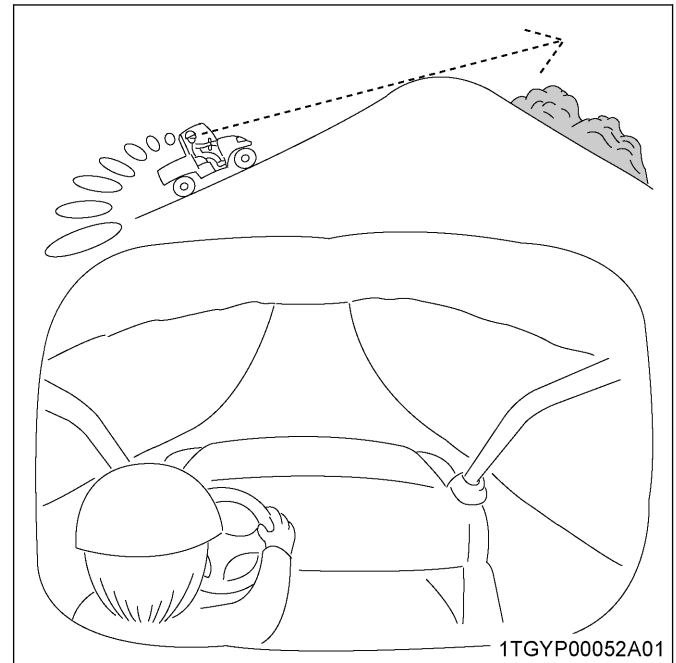

7. Traversing hillsides

WARNING

To avoid serious injury or death:

- Reduce vehicles speed to prevent tipping or loss of control.
- Do not traverse hillsides that are slippery or covered with rocks or obstacles which may cause you to tip over.

8. Sliding and skidding

WARNING

To avoid serious injury or death:

- Drive slowly and carefully when you are unsure or unprepared for the surface.
- Do not apply heavy braking force or accelerate when skidding to prevent loss of control.
- Use 4WD and maintain low speeds on areas covered with clay, mud, ice or snow to prevent uncontrolled skidding.

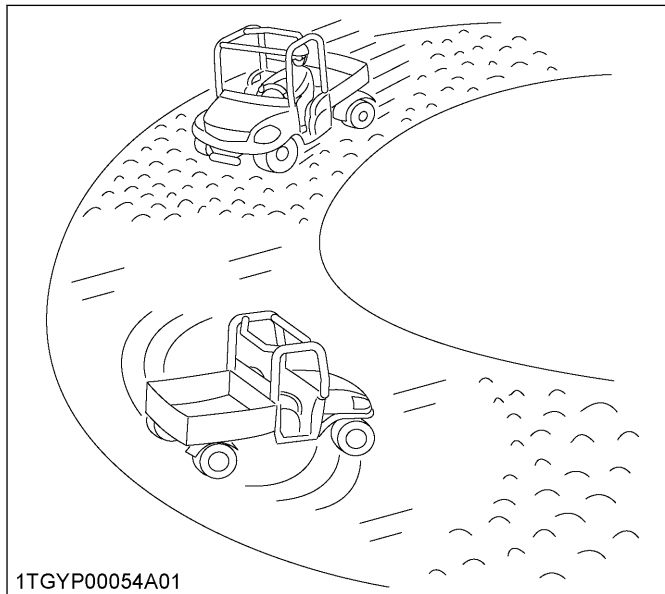

- Never operate the vehicle in the fast flowing water or in water deeper than the bottom edge of the axle caps.
- Wet brakes may reduce the stopping ability of the vehicle. After operating in water, always apply the brakes to dry them out.
- The brake that gets wet may wear out faster. Check for brake wear more frequently if operating in water often.

IMPORTANT :

- After operating the vehicle in water, remove the rubber plug from the CVT cover, check for accumulated water and drain it.

See the following figures.

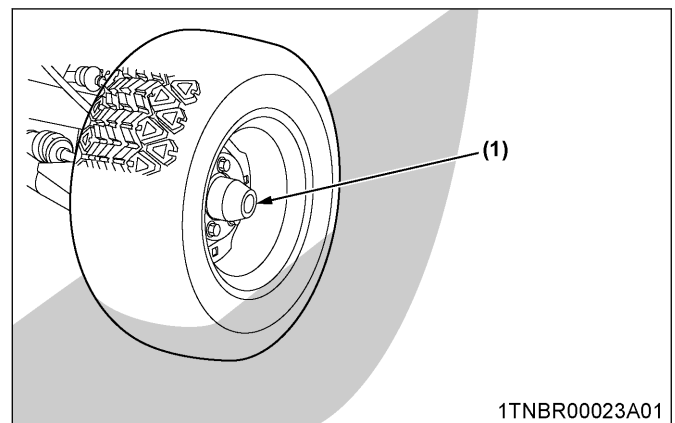
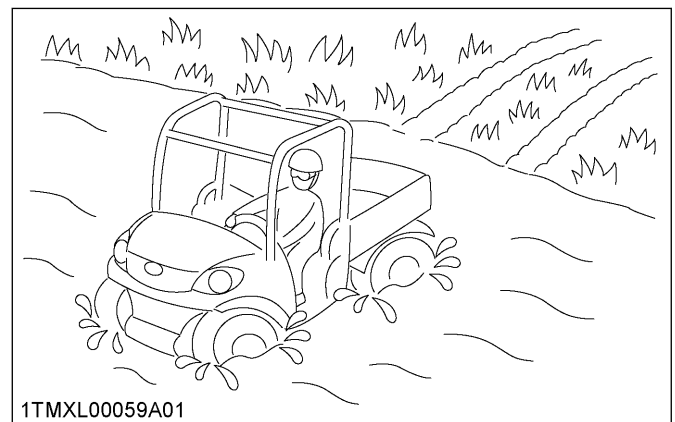

(1) Axle cap

9. Driving through water

WARNING

To avoid serious injury or death:

- Do not drive through water whenever it is possible.
- Drive slowly across shallow water and choose a location to enter and exit the water where the banks are not too steep or slippery.
- Before entering water, check for rocks, holes or other obstacles that may cause overturn, stuck or submerged.

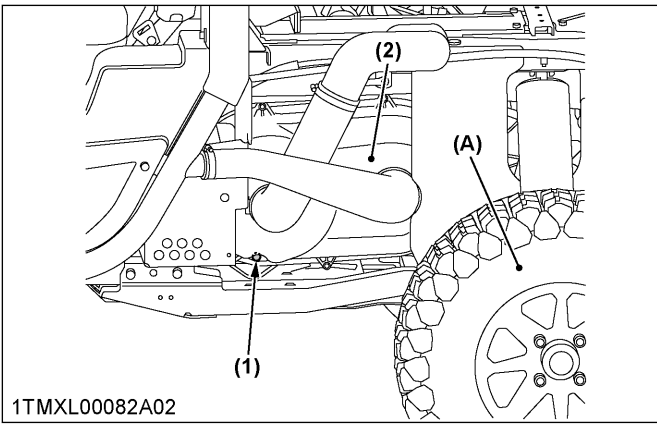

- (1) Rubber plug
- (2) CVT cover

(A) Left rear tire

CARGO BED

CARGO BED

1. Cargo bed general caution



WARNING

To avoid serious injury or death:

- Never carry passengers in the cargo bed. They can be tossed about or even thrown off causing serious injury or death.
- Never raise the cargo bed when it is loaded. (There is an exception. Only the vehicle equipped with electro-hydraulic dump may do this operation at operator's seat after appropriate confirmation of safety.)
- Driving with the cargo bed tilted may be hazardous.
Always lower the bed and latch the bed before driving.
- Be careful not to put any part of your body, such as hands or arms, between the bed and vehicle.
- Drive slowly when it is loaded.
- Secure the load before driving.

2. Max. cargo bed load

Never carry loads exceeding cargo bed capacity (CBC) and the permissible cargo bed load (PCBL).

CBC: cargo bed capacity

PCBL = PC - (operator + passenger + opt. + acc.) weight

PC: payload capacity

OP: operator

PA: passenger











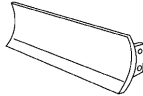
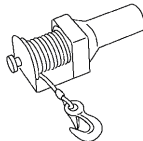

opt.: option

acc.: accessory

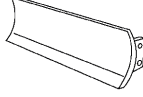
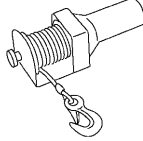
Payload capacity (PC)

Model	RTV-XG850		RTV-XG850 EVAP	
	General purpose model	Worksite model	General purpose model	Worksite model
Payload capacity	656 kg (1446 lbs.)	639 kg (1408 lbs.)	653 kg (1439 lbs.)	636 kg (1402 lbs.)

Quick reference table for cargo bed load

Model		Occupant*1	opt. + acc. (W)	Cargo bed capacity (CBC)	Permissible cargo bed load (PCBL)
RTV-XG850	General purpose model	 95 kg (209 lbs.)	 Blade weight +  Winch weight + other opt. and acc. weight (including tongue weights)	454 kg (1000 lbs.)	561 kg (1237 lbs.) - W
		 +  =190 kg (418 lbs.) 95 kg (209 lbs.) 95 kg (209 lbs.)			466 kg (1028 lbs.) - W
	Worksite model	 95 kg (209 lbs.)			544 kg (1199 lbs.) - W
		 +  =190 kg (418 lbs.) 95 kg (209 lbs.) 95 kg (209 lbs.)			449 kg (990 lbs.) - W
RTV-XG850 EVAP	General purpose model	 95 kg (209 lbs.)	 Blade weight +  Winch weight + other opt. and acc. weight (including tongue weights)	272 kg (600 lbs.)	558 kg (1230 lbs.) - W
		 +  =190 kg (418 lbs.) 95 kg (209 lbs.) 95 kg (209 lbs.)			463 kg (1021 lbs.) - W
	Worksite model	 95 kg (209 lbs.)			541 kg (1193 lbs.) - W
		 +  =190 kg (418 lbs.) 95 kg (209 lbs.) 95 kg (209 lbs.)			446 kg (984 lbs.) - W

*1 The calculation was made provided that the operator and the passenger weigh 95 kg each.

IMPORTANT :

- Cargo bed load should not exceed cargo bed capacity (CBC) and permissible cargo bed load (PCBL).
- Stability is decreased while loaded.
- Braking distance increases while loaded.

3. Cargo bed tailgate

⚠ WARNING

To avoid serious injury or death:

- Never carry passenger in the cargo bed or on the tailgate, otherwise passenger may be injured.
- Do not place fingers or hands between the tailgate and the arm (latch) when closing, or fingers or hands may be pinched.

For loading and unloading, the tailgate of the cargo bed can be opened.

The tailgate is held level to the cargo bed floor with wire loops.

Do not move the vehicle with the tailgate fully lowered.

1. Raise the arms (latch) at each end of the tailgate and open the tailgate.
2. Close the tailgate by lifting it and pushing it firmly closed. Push the arms (latch) down to make sure the latches stay securely closed.

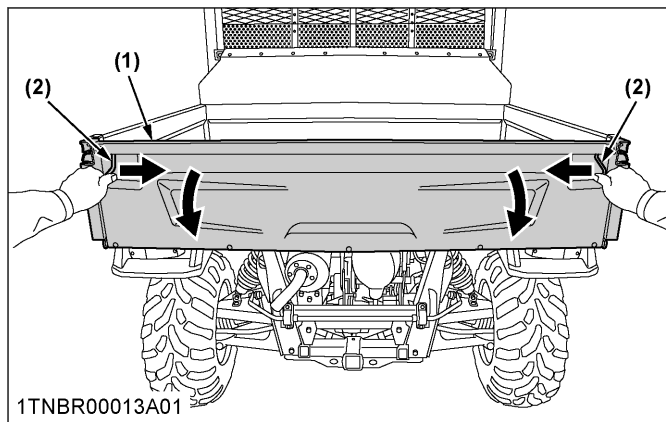

1TNBR00013A01

- (1) Tailgate
- (2) Arm (latch)

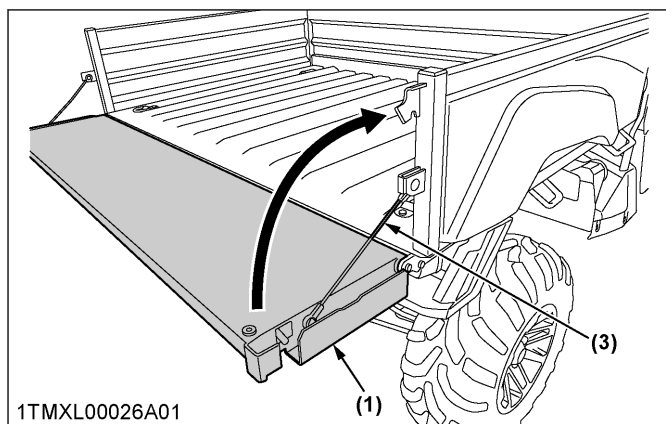

1TMXL00026A01

- (1) Tailgate
- (2) Arm (latch)
- (3) Wire loop

IMPORTANT :

- To avoid muffler damage:

- Do not remove the snap pin and wire loop.
- To avoid tailgate damage:
Do not operate for a long period of time with the cargo bed raised and the tailgate opened.
- Max weight on the tailgate during loading is 22.6 kg (50 lbs.).

4. Raising and lowering the cargo bed

⚠ WARNING

To avoid serious injury or death:

- Always lower and latch the bed before driving.
- Be careful not to catch any part of your body, such as hands or arms, between the bed and vehicle frame when lifting and lowering the bed. To prevent injury, use only the handgrips provided.

The cargo bed may be tilted.

1. Release the latches on each side, and then lift the bed with the handgrips.
2. Support the bed in the raised position with the safety support.

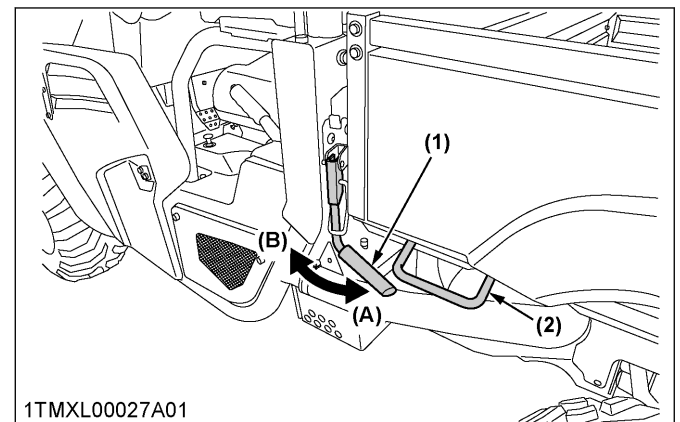

1TMXL00027A01

- (1) Latch
- (2) Handgrip
- (A) "LOCK"
- (B) "RELEASE"

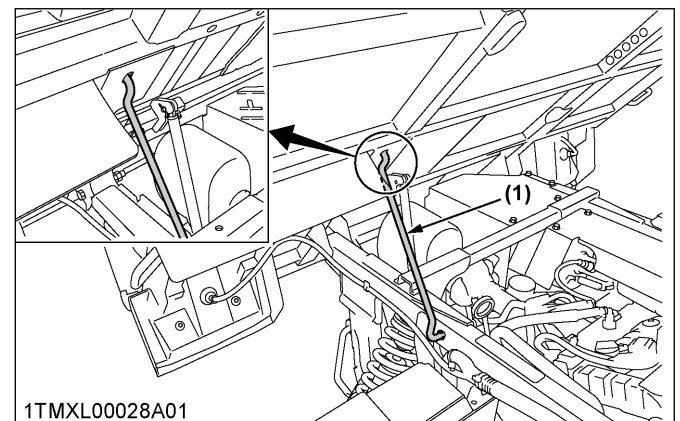

1TMXL00028A01

- (1) Safety support

TIRES AND WHEELS

TIRES

WARNING

To avoid serious injury or death:

- Do not attempt to mount a tire on a rim. This should be done by a qualified person with the proper equipment.
- Always maintain the correct tire pressure. Do not inflate tires above the recommended pressure shown in the operator's manual.

IMPORTANT :

- Do not use tires other than those approved by Kubota.

1. Inflation pressure

Though the tire pressure is factory-set to the prescribed level, it naturally drops slowly in the course of time. Thus, check it everyday and inflate as necessary.

Cargo bed load condition	Tire		Inflation pressure
0 to less than 550 lbs. (0 to less than 250 kg)	25 × 10 - 12 HDWS ATV	Front	120 kPa 1.2 kgf/cm ² 17 psi
		Rear	120 kPa 1.2 kgf/cm ² 17 psi
550 lbs. or more (250 kg or more)	25 × 10 - 12 HDWS ATV	Front	120 kPa 1.2 kgf/cm ² 17 psi
		Rear	170 kPa 1.7 kgf/cm ² 24 psi

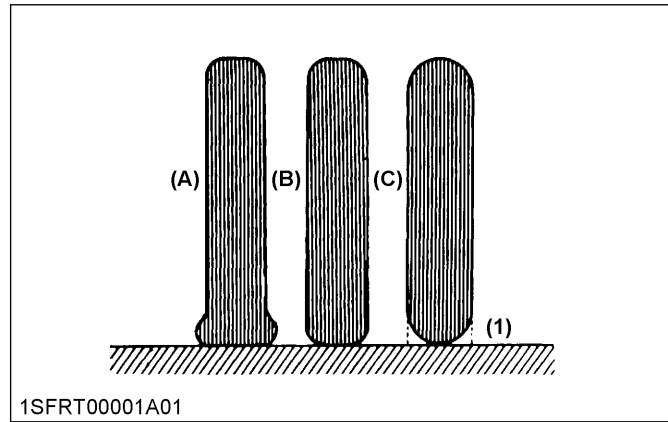

(1) Ground

- (A) "INSUFFICIENT"
- (B) "NORMAL"
- (C) "EXCESSIVE"

2. Tire type and use

Heavy duty work site tire (HDWS)

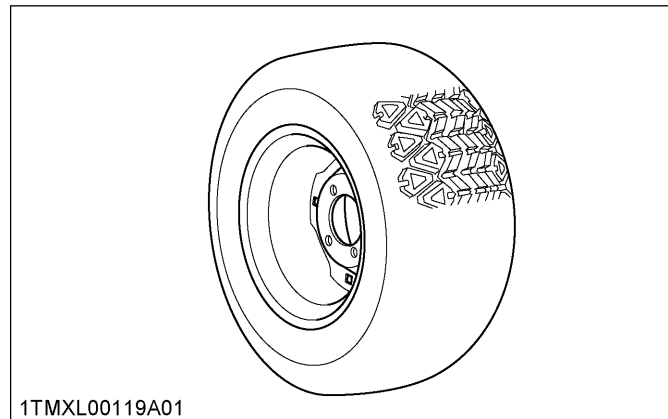

All terrain vehicle tire (ATV)

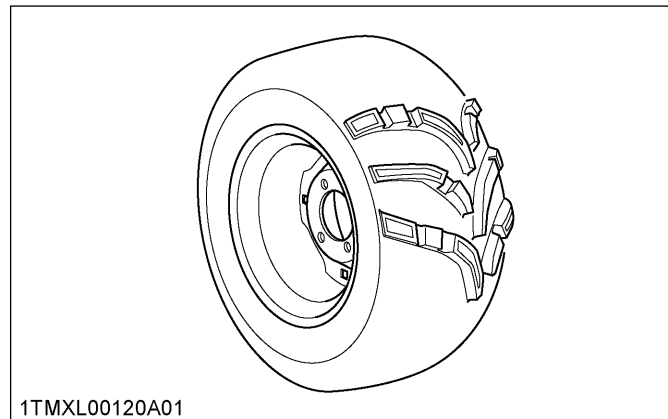

WHEELS

⚠️ WARNING

To avoid serious injury or death:

- Support vehicle securely on stands before removing a wheel.
- Never operate vehicle with loose wheel bolts and nuts.

IMPORTANT :

- When re-fitting a wheel, tighten the bolts and nuts to the following torques then recheck after driving the vehicle 200 m (220 yards) and thereafter according to service interval.

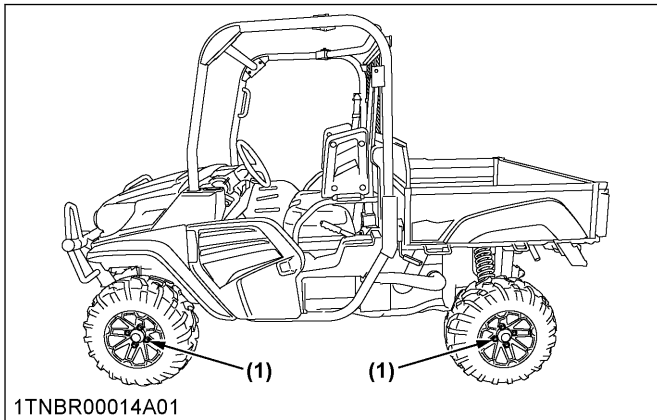

1TNBR00014A01

- (1) Tightening torque (nuts)
 Aluminum wheel, steel wheel: 130 to 150 N·m / 13.3 to 15.2 kgf·m / 95.9 to 110 lbf·ft

SHOCK ABSORBERS

1. Shock absorber spring adjustment

⚠️ WARNING

To avoid serious injury or death:

- Work on a firm, flat and level surface with the engine shut off and parking brake "ON".
- Keep the position of the left and right shock absorber equal for front and rear wheels. Uneven adjustment can cause poor handling and loss of control, which could lead to an accident.

IMPORTANT :

- Lift up the machine before adjusting the shock absorber spring.
 (See JACK-UP POINT on page 61.)

The spring adjusting sleeves on the front and rear shock absorbers have 5 positions so that the springs can be adjusted for different riding and loading conditions.

For adjusting the shock absorber springs, turn the adjusting sleeves on the shock absorbers to the desired position with the hook wrench.

The spring adjustment operation is in the direction of 1 to 5 or from the direction of 5 to 1.

Front and rear shock absorber position

Position	Spring	Feeling	Load
1	Weaker	Soft	Light
2 (default)	↑	↑	↑
3			
4	↓	↓	↓
5	Stronger	Hard	Heavy

IMPORTANT :

- To avoid wear or damage, do not change position directly from 5 to 1 or vice versa as seen below.

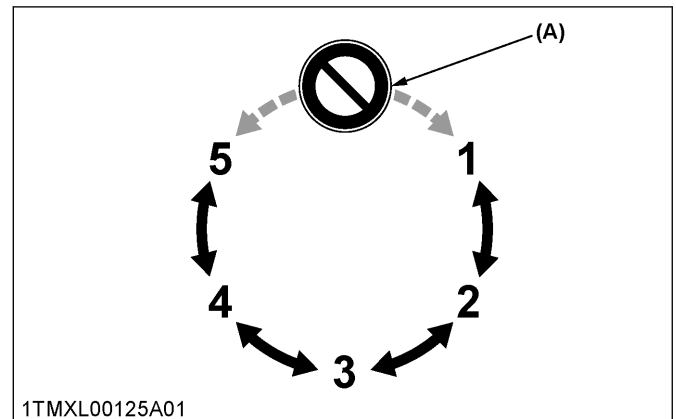

1TMXL00125A01

(A) Do not change position directly from 5 to 1 or vice versa.

NOTE :

- If you feel any difficulty in the adjustment, consult your local KUBOTA Dealer.

The shock absorber spring is adjusted to second position (default) in the figure below.

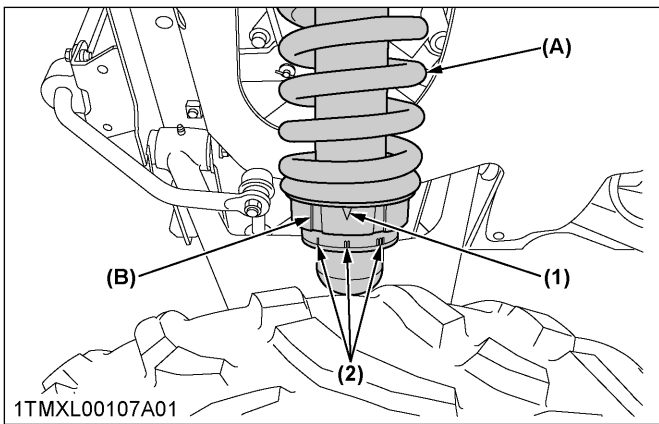

- (1) Position indicator marker (A) Shock absorber
(2) Position mark (I, II, III, ...) (B) Adjusting sleeve (Turn here with a hook wrench.)

TOWING AND TRANSPORTING

TOWING AND TRANSPORTING

1. Rear trailer hitch (if equipped)

⚠ WARNING
 To avoid serious injury or death:

- Always tow a load slowly enough to maintain control and avoid tipping.
- To provide adequate braking ability and traction, do not tow a load unless vehicle cargo bed is loaded or attachment is installed.
- Attach a trailer to the trailer hitch only.

Details regarding the rear trailer hitch load can be found in a different section.
 (See VEHICLE LIMITATIONS on page 21.)
 When towing other equipment, use a safety chain.

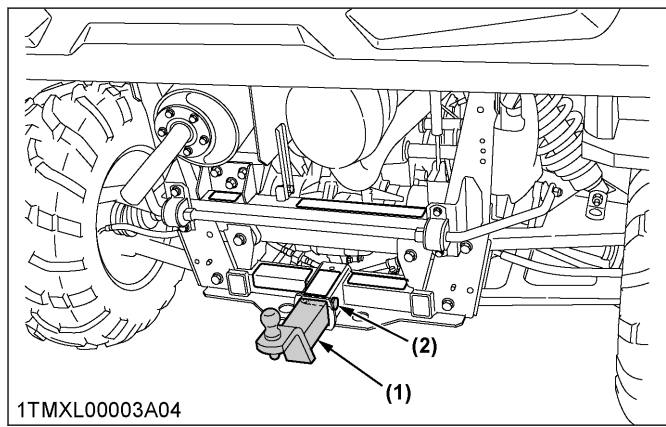

(1) Rear trailer hitch (if equipped)
 (2) Hitch pin (if equipped)

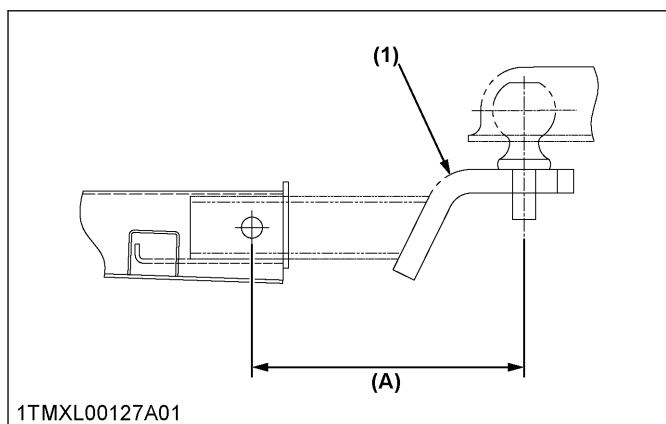

(1) Rear trailer hitch (if equipped) (A) Maximum 8.9 inches (225 mm)

2. Front trailer hitch (if equipped)

⚠ WARNING
 To avoid serious injury or death:

- Do not tow with this vehicle unless all the functions of the vehicle are properly working, since the malfunction of steering operation or braking may cause an accident.

Use the front trailer hitch for greater maneuverability in confined areas such as a barn.
 Details regarding the front trailer hitch load can be found in a different section.
 (See VEHICLE LIMITATIONS on page 21.)

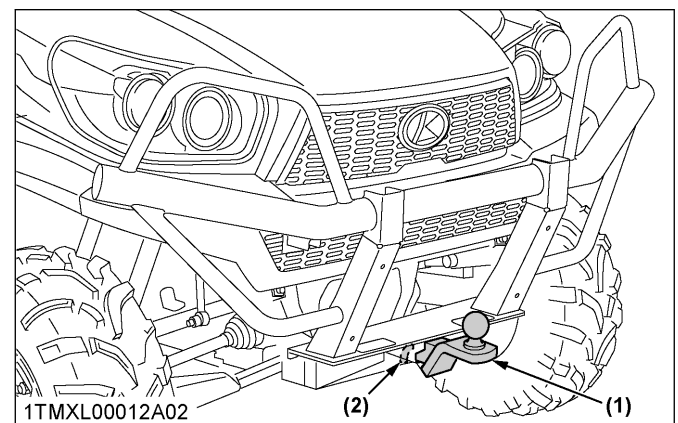

(1) Front trailer hitch (if equipped)
 (2) Hitch pin (if equipped)

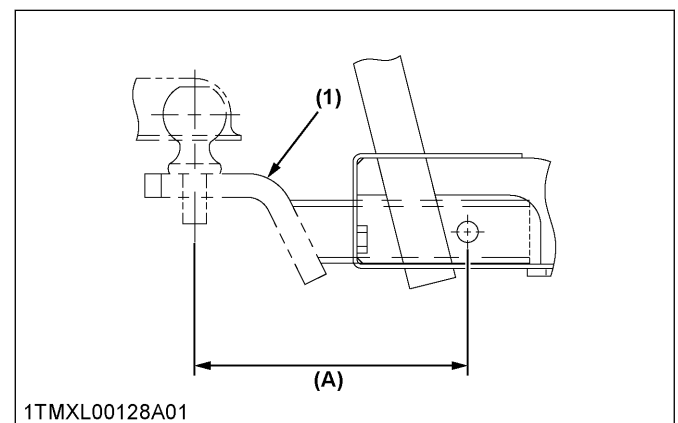

(1) Front trailer hitch (if equipped) (A) Maximum 8.9 inches (225 mm)

3. Winch mount bracket

Mounting the optional winch always requires reading the instruction manual attached to the winch thoroughly before using it.

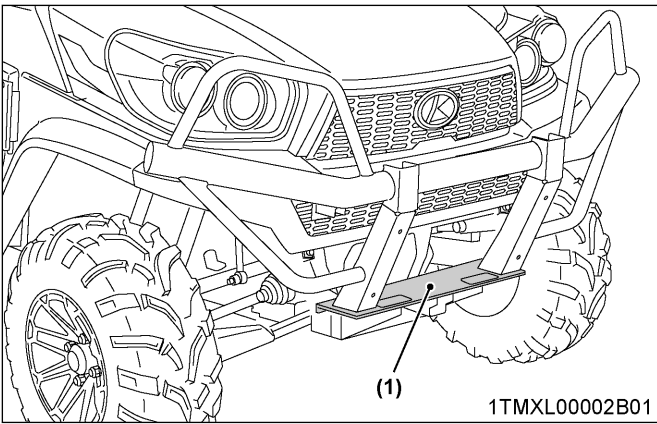

(1) Winch mount bracket

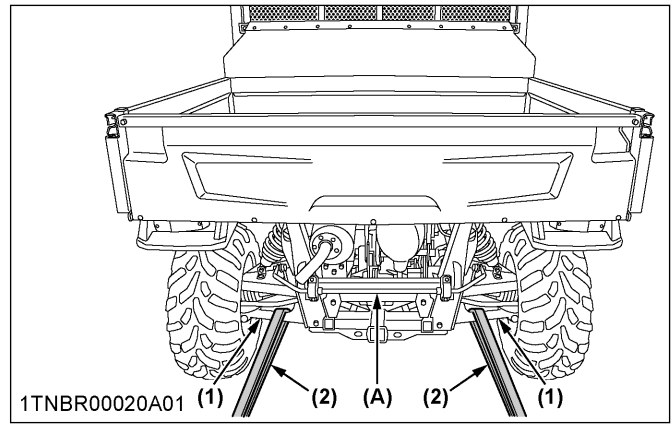

(1) Lower arm (A) Rear stabilizer
(2) Heavy-duty strap

4. Transport the vehicle safely

Pay attention to the points below when transporting the vehicle.

1. Apply the parking brake and place chocks against the front and rear tires.
2. Secure the portions of the vehicle, which are shown in the figure below, by using adequate straps or chains.
3. When transporting vehicle on truck or trailer, always comply with Federal and/or Local regulations for securement.

IMPORTANT :

- Do not apply the straps and chains to the rear stabilizer.

Follow below when towing the vehicle: Otherwise, the vehicle's powertrain may get damaged.

- Set the all shift levers to "NEUTRAL" position.
- If possible, start engine and select 2WD, if creep speed is fitted ensure that it is disengaged.
- Tow the vehicle using its front hitch or drawbar.
- Never tow faster than "10 km/h (6.2 mph)".

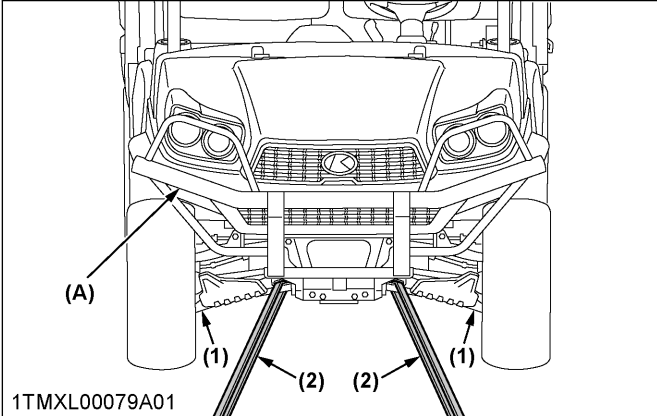

(1) Lower arm (A) Front guard
(2) Heavy-duty strap

MAINTENANCE

 WARNING

To avoid serious injury, death or vehicle damage:

- Be sure you have sufficient knowledge, experience, the proper replacement parts and tools before you attempt any vehicle maintenance task.
- If you do not have the knowledge and equipment which are necessary to perform the maintenance task, consult your local KUBOTA Dealer.
- Have your local KUBOTA Dealer perform inspection of the items which are marked *6 in the following chart.

SERVICE INTERVALS

Items		Indication of hour meter (hr) (Indication of odometer-km)											Interval	Ref. Page	
		20	50 (1500)	100 (3000)	150 (4500)	200 (6000)	250 (7500)	300 (9000)	350 (10500)	400 (12000)	450 (13500)	500 (15000)			
Engine oil	Change	☆		○		○		○		○		○	every 100 hrs (3000 km)	73	*1 *2
Engine oil filter	Replace	☆				○				○			every 200 hrs (6000 km)	80	*2
Engine start system	Check		○	○	○	○	○	○	○	○	○	○	every 50 hrs (1500 km)	69	
Greasing	Apply		○	○	○	○	○	○	○	○	○	○	every 50 hrs (1500 km)	69	*3
Wheel fastener torque	Check		⊙	○		○		○		○		○	every 100 hrs (3000 km)	71	*4
CVT belt	Check		⊙	○		○		○		○		○	every 100 hrs (3000 km)	77	*1 *4 *5 *6 *7
Brake pedal	Check		⊙			○				○			every 200 hrs (6000 km)	79	*4
Brake light	Check		⊙			○				○			every 200 hrs (6000 km)	79	*4
Parking brake	Adjust		⊙			○				○			every 200 hrs (6000 km)	79	*4
Brake pad wear	Check			○		○		○		○		○	every 100 hrs (3000 km)	71	
Toe-in	Adjust			○		○		○		○		○	every 100 hrs (3000 km)	76	
Battery condition	Check			○		○		○		○		○	every 100 hrs (3000 km)	74	*8
Fuel pump filter	Check			○		○		○		○		○	every 100 hrs (3000 km)	73	*6
Muffler (spark arrester)	Clean			○		○		○		○		○	every 100 hrs (3000 km)	77	

(Continued)

MAINTENANCE

Items		Indication of hour meter (hr) (Indication of odometer-km)										Interval	Ref. Page		
		20	50 (1500)	100 (3000)	150 (4500)	200 (6000)	250 (7500)	300 (9000)	350 (10500)	400 (12000)	450 (13500)				500 (15000)
Exhaust system	Check			○		○		○		○		○	every 100 hrs (3000 km)	77	+7
Air cleaner element	Clean			○		○		○		○		○	every 100 hrs (3000 km)	72	+9 *10
	Replace												every 1000 hrs or every year	83	*10 *11
Transmission gear shift switch	Check			○		○		○		○		○	every 100 hrs (3000 km)	77	+6 +7
Carbon canister air filter (California only)	Check			○		○		○		○		○	every 100 hrs (3000 km)	78	+7 *10 *12
	Replace												every 2 years	89	+6 *10 *12
Suspension arm bushings	Check				○ ^{*13} (3000)				○ ^{*13} (6000)				every 200 hrs (3000 km)	79	+6 *13
Spark plug condition and gap	Check				○				○				every 200 hrs (6000 km)	80	*10
	Replace											○	every 500 hrs (15000 km)	—	*10
Engine valve clearance	Check				○				○				every 200 hrs (6000 km)	81	+6 *10
Transmission fluid	Change								○				every 400 hrs (12000 km)	81	
Front axle case oil	Change								○				every 400 hrs (12000 km)	82	
Purge valve (California only)	Check											○	every 500 hrs (15000 km)	82	+7 *10 *12
Brake hose and pipe	Check												every year	87	+7
	Replace												every 4 years	89	+6
Fuel line	Check												every year	83	+7 *10
	Replace												every 4 years	89	+6 *10
Radiator hose, pipe and clamp	Check												every year	84	+7
	Replace												every 4 years	89	+6
Intake air line	Check												every year	85	+7 *10
	Replace												every 4 years	89	+6 *10
CVT intake air line	Check												every year	85	+7
Engine breather hose	Check												every year	86	+7
	Replace												every 4 years	89	+6
Brake fluid	Change												every 2 years	87	+6
Cooling system	Flush												every 2 years	87	
Coolant	Change												every 2 years	87	
Brake master cylinder (inner parts)	Replace												every 4 years	89	+6

(Continued)

Items		Indication of hour meter (hr) (Indication of odometer-km)										Interval	Ref. Page		
		20	50 (1500)	100 (3000)	150 (4500)	200 (6000)	250 (7500)	300 (9000)	350 (10500)	400 (12000)	450 (13500)				500 (15000)
Brake caliper (inner parts)	Replace												every 4 years	89	*6
Fuse	Replace												Service as required	89	
Light bulb	Replace													91	

- *1 Vehicles subjected to extreme operations and/or conditions as follows must be inspected and serviced more frequently.
- *2 The initial 20 hours should not be a replacement cycle.
- *3 Lubricate grease fittings daily, if you operate in wet and muddy conditions.
- *4 The initial 50 hours should not be a replacement (change, check, adjustment) cycle.
- *5 Every 100 hours or every 3000 km, whichever comes first.
- *6 Consult your local KUBOTA Dealer for this service.
- *7 Replace if any deterioration (crack, hardening, scar, or deformation) or damage occurred.
- *8 When the battery is used for less than 100 hours per year, check the battery condition by reading the indicator annually.
- *9 Air cleaner should be cleaned more often in dusty conditions than in normal conditions.
- *10 Emission-related service (failure to conduct this maintenance will not void the emissions warranty but may affect emissions).
- *11 Every 1000 hours or every year, whichever comes first.
- *12 California only
- *13 Every 200 hours or 3000 km, whichever comes first.

IMPORTANT :

- **The jobs indicated by ○ must be done after the first 50 hours of operation.**
- **Changing engine oil and engine oil filter indicated by ☆ must be done after the first 20 hours of operation.**
- **Gasoline engine emission related maintenance instructions:**
 - **Non-warranty maintenance, repair, or replacement of the emission control devices and systems should be performed by a qualified repair establishment or individual which has the experience and equipment to perform such work.**
See the Emissions Warranty Statement.
 - **To ensure the best quality and reliability, use new KUBOTA Genuine parts or their equivalents for repair and replacement, whenever you have maintenance done.**

EPA emissions limited maintenance:

- Any qualified repair shop or person may maintain, replace, or repair the emission control devices or systems on your vehicle. (See “*EMISSION RELATED WARRANTY*”.)
KUBOTA recommends that you contact an authorized KUBOTA Dealer to perform any service that may be necessary for your vehicle. KUBOTA also recommends that you use only KUBOTA genuine parts.

Extreme conditions described in the previous table's *1 note:

1. Frequent or prolonged operations in dusty environments
2. Prolonged low speed operations
3. Extended idle time
4. Frequent short trips which do not let the engine warm up (especially in cold weather)

LUBRICANTS, FUEL AND COOLANT

No.	Locations	Capacities	Lubricants
1	Fuel	31.9 L (8.4 U.S.gals.)	<ul style="list-style-type: none"> • Automobile unleaded or regular gasoline • Unleaded gasoline 87 octane or higher • Gasohol (E10 or less)
2	Coolant (with reserve tank)	6.0 L (6.3 U.S.qts.)	Fresh clean water with antifreeze
3	Engine crankcase	[Filter exchanged] 3.8 L (4.0 U.S.qts.) * [Filter non-exchanged] 3.6 L (3.8 U.S.qts.) *	<ul style="list-style-type: none"> • Engine oil: API Service Classification SH, SJ or higher • See the following chart for information about SAE oil grade.
4	Transmission case	2.5 L (2.6 U.S.qts.)	KUBOTA UDT or SUPER UDT-2 fluid **
5	Front axle case	0.6 L (0.6 U.S.qts.)	KUBOTA UDT or SUPER UDT-2 fluid **
6	Brake fluid (reservoir and lines)	0.28 L (0.3 U.S.qts.)	KUBOTA DOT3 GENUINE BRAKE FLUID

* Oil amount when the oil level is at the upper level of the oil level gauge.

** KUBOTA UDT or SUPER UDT-2 fluid --- KUBOTA original transmission hydraulic fluid

Greasing	No. of greasing points	Capacity	Type of grease
Parking brake lever	2	Moderate amount	Multipurpose EP2 Grease (NLGI Grade No. 2)
Battery terminal	2		
Cargo lift cylinder pivot	1	Until grease overflow	
Cargo bed pivot	2	Moderate amount	
4WD lever link	1		
Range gear shift link	1		
Differential lock pedal	2		
Front A-ARM	6	Until grease overflow	
Rear A-ARM	8		

Engine oil:

- Oil used in the engine should have an American Petroleum Institute (API) service classification and Proper SAE Engine Oil according to the ambient temperatures as shown as follows:

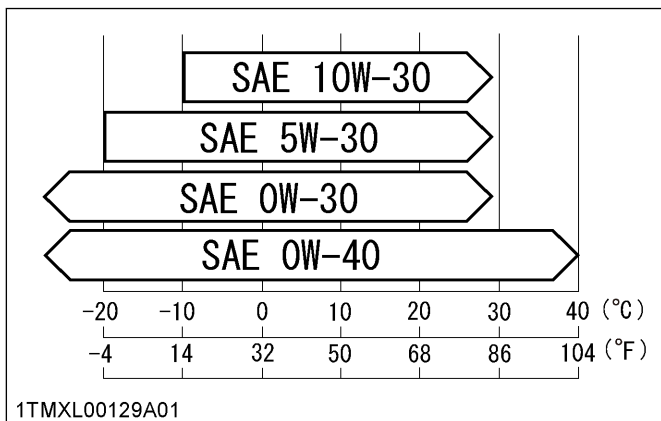

Fuel:

- Gasohol (up to 10 % ethyl alcohol, 90 % unleaded gasoline by volume) is approved for the engine. Other gasoline/ alcohol blends are not approved.

Transmission oil:

To complete lubrication of the transmission, it is important that a multi-grade transmission fluid is used in this system. We recommend the use of KUBOTA UDT or SUPER UDT-2 fluid for optimum protection and performance. (Consult your local KUBOTA Dealer for further detail.)

Do not mix different brands or grades.

Brake fluid:

Always use KUBOTA DOT3 GENUINE BRAKE FLUID from a sealed container. If it is not available, you should use only DOT3 fluid as a temporary replacement from a sealed container.

However, the use of any non-KUBOTA brake fluid can cause corrosion and decrease the life of the system.

When you use DOT3 fluid other than KUBOTA DOT3 GENUINE BRAKE FLUID, we strongly recommend to have the brake system flushed and refilled with KUBOTA DOT3 GENUINE BRAKE FLUID as soon as possible.

Indicated capacity of water and oil are manufacturer's estimate.

PERIODIC SERVICE

WARNING

To avoid serious injury or death:

- Do not work under any hydraulically supported devices. They can settle, suddenly leak down, or be accidentally lowered. If necessary to work under vehicle or any vehicle elements for servicing or adjustment, securely support them with stands or suitable blocking beforehand.

HOW TO OPEN THE HOOD AND TILT THE SEAT

WARNING

To avoid serious injury or death from contact with moving parts:

- Never open the cover under the seat while the engine is running unless servicing requires such access.

1. Hood

To open the hood, pull the latch lever toward left side of machine to release the latch and open the hood.

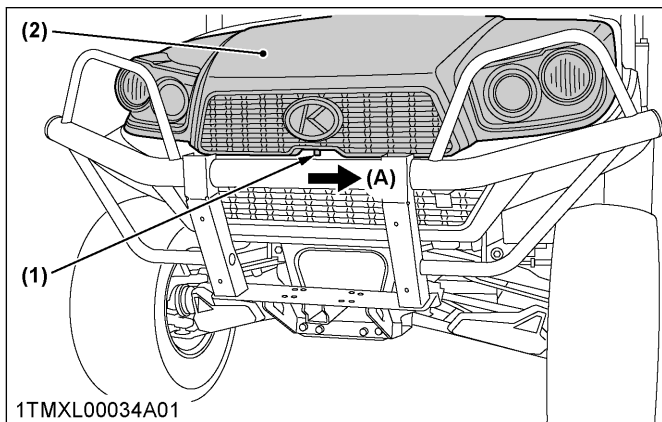

1TMXL00034A01

- (1) Latch lever
(2) Hood

(A) "RELEASE"

NOTE :

- To close the hood, press-fit the hood into position with both hands.

2. Seat

1. To open the seats, raise the seats to the forward position.

2. Remove the utility box and maintenance cover.

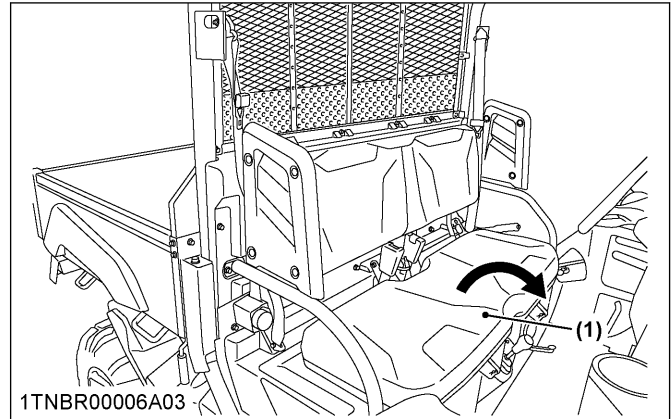

1TNBR00006A03

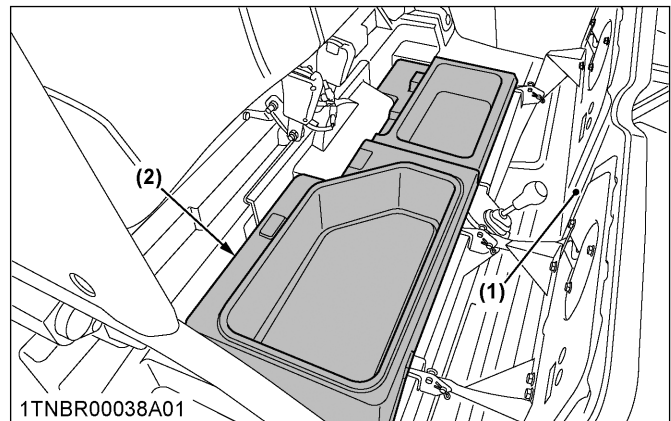

1TNBR00038A01

- (1) Seat
(2) Utility box

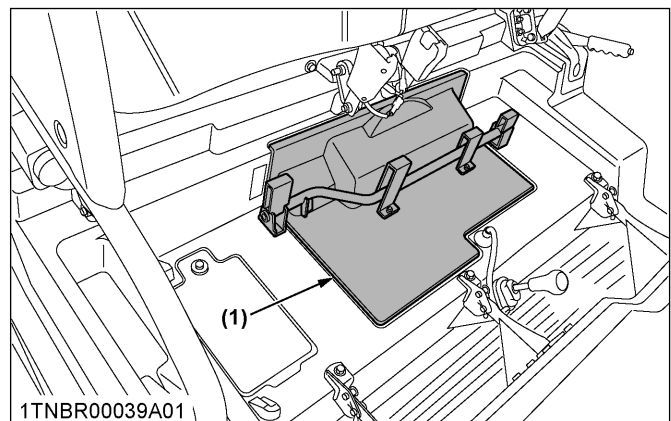

1TNBR00039A01

- (1) Maintenance cover

HOW TO RAISE THE CARGO BED

⚠ WARNING
 To avoid serious injury or death:

- When servicing under raised bed, make sure safety support is properly mounted.
- Do not touch muffler or exhaust pipes while they are hot; severe burns could result.

1. Raising and lowering the cargo bed

See Raising and lowering the cargo bed on page 49.

JACK-UP POINT

⚠ WARNING
 To avoid serious injury, death or vehicle damage:

- Do not work under the vehicle unless it is secured by safe stands or suitable blocking.

1. Front end

Jack up at the plate under the front axle case only.

NOTE :

- Before jacking up the vehicle, park it on a firm and level ground and chock the rear wheels.
- Select a jack that withstands the vehicle weight and set it up as shown below.

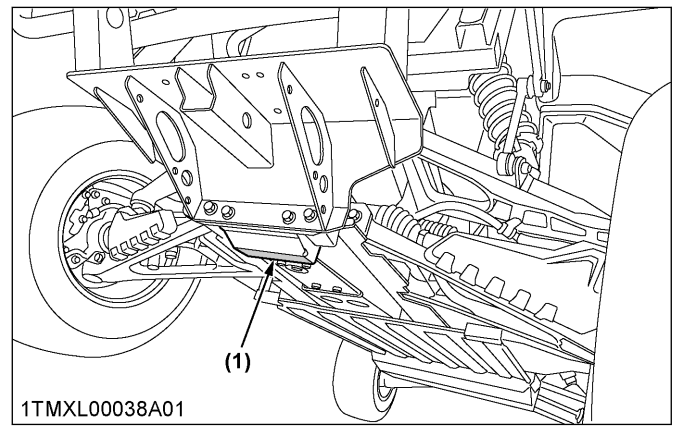
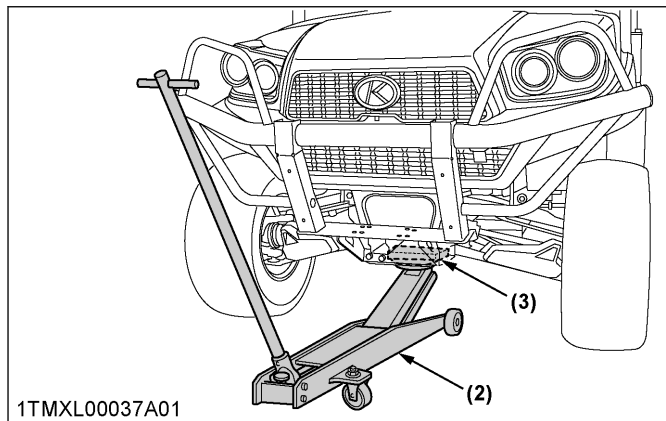

- (1) Plate under the front axle case
- (2) Jack
- (3) Wooden block

2. Rear end

Jack up the rear end after placing a wooden block under the bottom plate of the transmission frame.

NOTE :

- Before jacking up the vehicle, park it on a firm and level ground and chock the front wheels.
- Select a jack that withstands the vehicle weight and set it up as shown below.

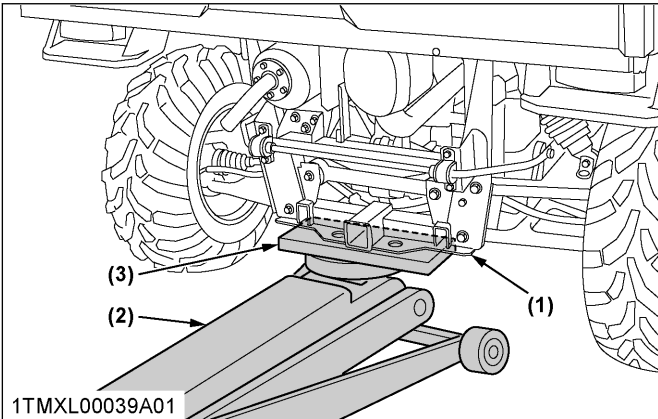
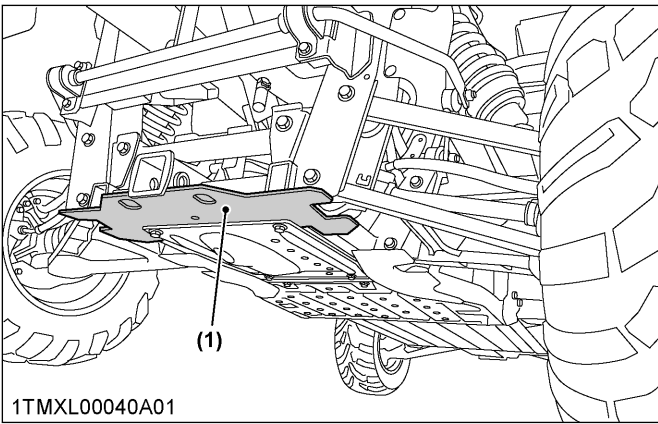

- (1) Bottom plate of the transmission frame
- (2) Jack
- (3) Wooden block

IMPORTANT :

- To avoid damage to frame, do not pick up on the rear upper cross member when hoisting the vehicle.

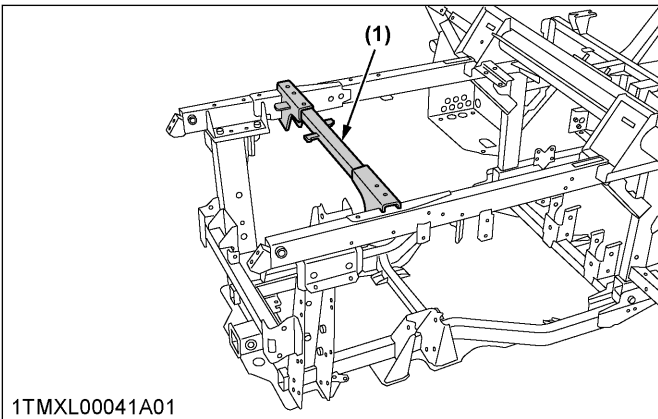

- (1) Rear upper cross member

DAILY CHECK

For your own safety and maximum service life of the vehicle, make a thorough daily inspection before operating the vehicle to start the engine.

! WARNING

To avoid serious injury or death:

- Check and service the vehicle on a flat surface with the engine shut off and the parking brake “ON”.

1. Walk around inspection

Look around and under the vehicle for such items as loose bolts, trash build-up, oil or coolant leaks, broken or worn parts.

2. Checking around engine

1. Park the vehicle on a level surface.
2. Stop the engine.
3. Raise the cargo bed.
4. Mount the safety support.
5. Check around the engine for mud or foreign materials.
6. Ensure that area surrounding the covers for the exhaust pipe, muffler and so on are free of flammable materials such as straw, debris and so on.
7. Remove all foreign materials if they are found.
8. Check the air cleaner primary element. If dry dust adheres to the element, clean it.
(See Cleaning air cleaner primary element on page 72.)

3. Checking amount of fuel and refueling

! WARNING

To avoid serious injury or death:

- Fuel is highly flammable. Always handle fuel with care. Handle fuel carefully. If the engine is running, do not fill the fuel tank. If engine is hot, let engine cool several minutes before adding fuel. Do not smoke while filling the fuel tank or servicing the fuel system.
- Fill fuel tank in an area away from any flames or sparks. Fill fuel tank only to bottom of filler neck. Do not fill completely full. The empty space in the tank allows gasoline to expand, when it heats up. Never remove the fuel tank cap or add fuel when the fuel tank is hot.
- Close the fuel tank cap after refueling.



1SFRT00004A01

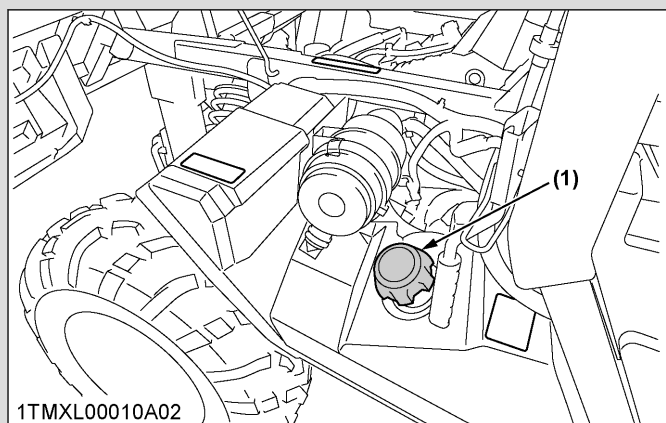

1TMXL00010A02

(1) Fuel tank cap

Check the fuel level. Take care that the fuel tank does not become empty.

Before refueling, clean dirt, mud, debris and water from the fuel tank cap and surrounding area to prevent them from entering the fuel tank.

Accumulation of moisture or sediment in the fuel system can restrict the flow of fuel and cause fuel pump and engine damage.

Fuel tank capacity	31.9 L (8.4 U.S.gals.)
--------------------	------------------------

IMPORTANT :

- Do not mix oil with gasoline. Use only unleaded gasoline with an octane rating index of 87 or higher may be used.

NOTE :

- Use fuel within approximately 30 days after purchase to avoid deterioration in fuel quality, or add fuel stabilizer to keep fuel fresh and stabilized.
- Fuel blend differs from season to season for the best seasonal engine performance. To prevent engine performance troubles such as vapor lock or hard starting, use fuel within the season in which the fuel is purchased.
- Infrequent use of the engine during a season can make fuel stale in the fuel tank of the machine. Stale fuel condition can cause engine

performance troubles by varnish and plugged engine components.

- Seal the fuel storage container tightly and store it out of sunlight and heat to prevent fuel degradation.
- Condensation in the fuel tank may occur because of various operating or environmental conditions. To reduce condensation and avoid affecting machine operation, fill the fuel tank at the end of daily operation and store fuel in the container.
- Use only an approved fuel container. Use only nonmetal, portable fuel containers approved by the Underwriter's Laboratory (U.L.) or the American Society for Testing & Materials (ASTM). If using a funnel, make sure it is plastic and has no screen or filter.
- Never remove the fuel tank cap or add fuel with the engine running. Allow the engine to cool before refueling.
- Never add fuel to or drain fuel from the machine indoors. Move the machine outdoors and provide adequate ventilation.
- Clean up spilled fuel immediately. If fuel is spilled on clothing, change clothing immediately. If fuel is spilled near machine, do not attempt to start the engine but move the machine away from the area of spillage. Avoid creating any source of ignition until fuel vapors have dissipated.
- Never store the machine or fuel container where there is an open flame, spark, or pilot light such as on a water heater or other appliance.
- Prevent fire and explosion caused by static electric discharge. Static electric discharge can ignite fuel vapors in an ungrounded fuel container.
- Never fill containers inside a vehicle or on a truck or a trailer bed with a plastic liner. Always place containers on the ground away from your vehicle before fueling.

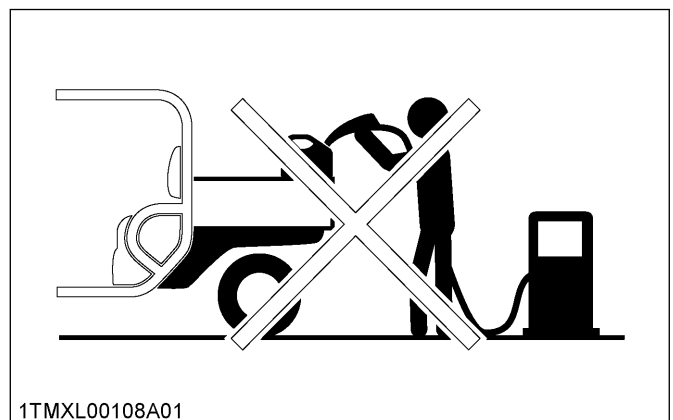

1TMXL00108A01

- Remove fuel-powered equipment from the truck or the trailer and refuel it on the ground. If this is not possible, then refuel such equipment with

a portable container, rather than from a fuel dispenser nozzle.

- Keep the nozzle in contact with the rim of the fuel tank or container opening at all times until the fueling is complete. Do not use a nozzle lock-open device.
- Never overfill fuel tank. Replace the fuel tank cap and tighten securely.
- Replace all fuel container caps securely after use.
- For gasoline engines, do not use gas with methanol. Methanol is harmful to your health and to the environment.

IMPORTANT :

- Do not use stale fuel.
- Fill fuel tank at the end of daily operation to prevent condensation in the fuel tank.
- Before refueling, clean dirt, mud, debris and water from the fuel tank cap and surrounding area.

Use of alcohol mixed gasoline (gasohol: E10 or less)

Use “gasohol” only when the ethanol additive is less than 10 % of the fuel. The use of methanol additive is not recommended. For the best results, use unleaded fuel with a minimum of 87 octane.

4. Checking engine oil level

⚠ WARNING
To avoid serious injury or death:

- Stop the engine before checking the oil level.

1. Park the vehicle on a level surface.
2. Raise the cargo bed and mount the safety support.
3. Stop the engine and remove the key.
4. Allow the engine to cool for 10 minutes or more.
5. Open the seats and remove the utility box.
6. Open the maintenance cover to access the engine part.
7. To check the oil level, draw out the dipstick, wipe it clean and reinstall it.

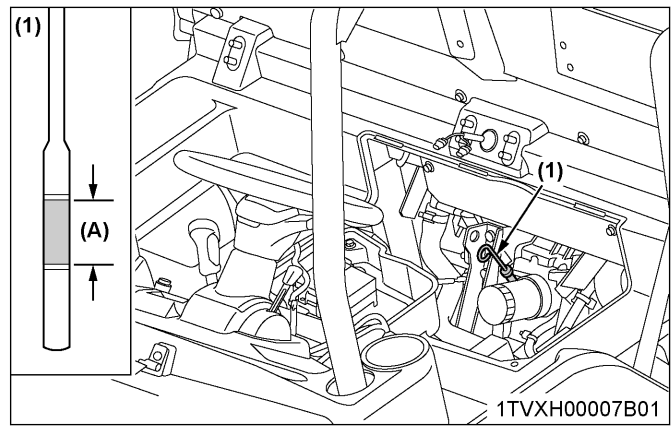

(1) Dipstick (A) Oil level is acceptable within this range.

8. After 10 seconds or more, draw it out again. Check to see that the oil level lies between the 2 lines.
9. If the level is too low, add new oil to the prescribed level at the oil inlet.
 (See LUBRICANTS, FUEL AND COOLANT on page 58.)

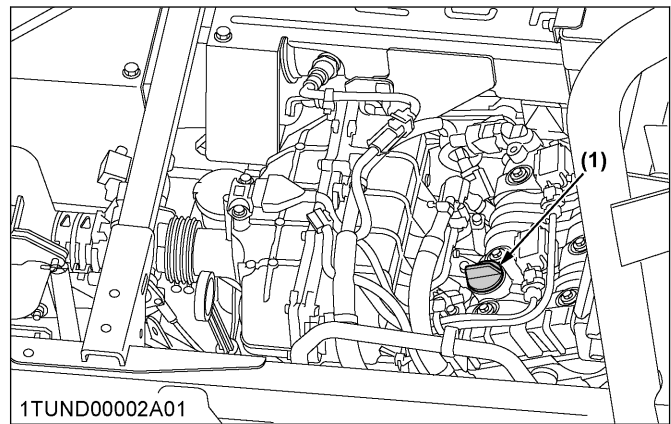

(1) Oil inlet

IMPORTANT :

- When using an oil of different maker or viscosity from the previous one, remove all of the old oil. Never mix 2 different types of oil.
- If oil level is low, do not run engine.
- Clean the area around dipstick and oil inlet before removing or loosening them.

5. Checking transmission fluid level

1. Park the vehicle on a level surface.
2. Stop the engine.
3. Raise the cargo bed and mount the safety support.
4. To check the oil level, draw out the dipstick, wipe it clean, replace it, and draw it out again. Check to see that the oil level lies within the range as shown in the figure.

5. If the level is too low, add new oil within the prescribed range on the dipstick.
(See LUBRICANTS, FUEL AND COOLANT on page 58.)

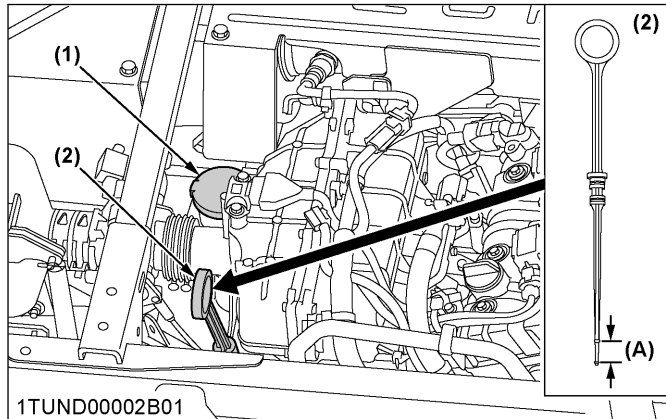

- (1) Oil inlet
(2) Dipstick

(A) Oil level is acceptable within this range.

6. Checking coolant level

WARNING

To avoid serious injury or death:

- Do not remove radiator cap while coolant is hot. When cool, slowly rotate cap to the first stop and allow sufficient time for excess pressure to escape before removing the cap completely.

- Park the vehicle on a level surface.
- Stop the engine.
- Open the hood.
- Check to see that the coolant level is between the **[FULL]** and **[LOW]** marks of recovery tank.
- When the coolant level drops due to evaporation, add water only up to the full level. In case of leakage, add antifreeze and water in the specified mixing ratio up to the full level.
(See Flushing cooling system and changing coolant on page 87.)

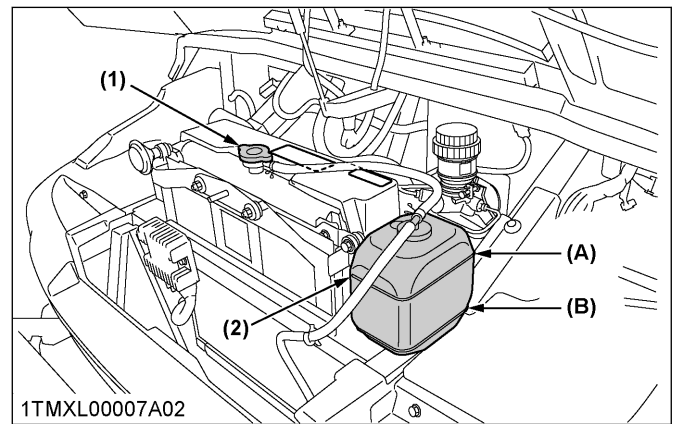

- (1) Radiator cap
(2) Recovery tank

(A) **[FULL]**
(B) **[LOW]**

IMPORTANT :

- If the radiator cap has to be removed, follow the warning above and securely retighten the cap.
- Use clean, fresh water and antifreeze to fill the recovery tank.
- If water should leak, consult your local KUBOTA Dealer.

7. Cleaning radiator screen

WARNING

To avoid serious injury or death:

- Stop the engine before removing the screen.
- Before checking or cleaning the radiator screen, stop the engine and wait long enough until it is cooled down.

- Park the vehicle on a flat surface.
- Stop the engine.
- Open the hood.

- Detach the screen and remove all foreign materials.

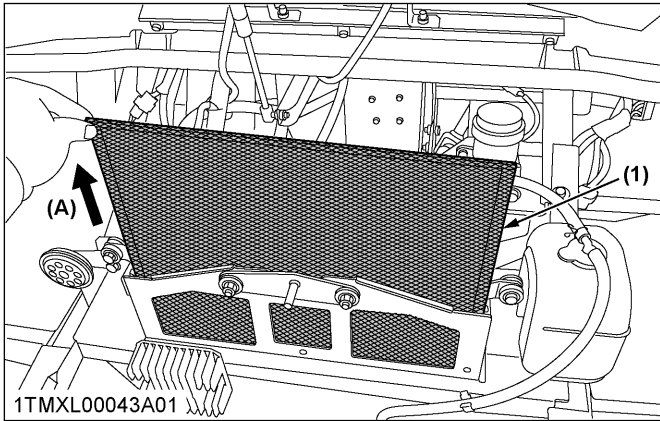

(1) Radiator screen (A) "DETACH"

IMPORTANT :

- Radiator screen must be clean from debris to prevent engine from overheating.

8. Checking drain cap

- Make sure that the drain cap under the intake pipe is free from oil, water, and other foreign materials.
- If foreign materials have accumulated, remove the drain cap, dispose of the foreign materials and clean the cap.
- Return the drain cap to the original position and secure with a clamp.

IMPORTANT :

- Inspect the drain cap under the intake pipe for debris and for proper sealing.

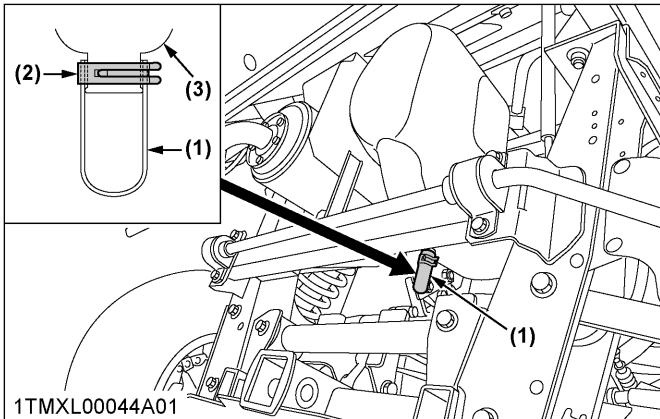

(1) Drain cap
(2) Clamp
(3) Intake pipe

9. Checking brake fluid level

WARNING

To avoid serious injury or death:

- Never operate the vehicle, if the brake fluid is below the [MIN] mark.
- For your safety we strongly recommend KUBOTA DOT3 GENUINE BRAKE FLUID from a sealed container. Using other type of oil damages synthetic resin or rubber installed in brake system components, and may cause brake failure.
- Avoid contamination of the brake fluid. Thoroughly clean area around the filler cap before removing. Do not open the brake fluid reservoir cap unless absolutely necessary.
- Use extreme care when filling the reservoir. If brake fluid is spilled on the power steering hose, wash off with water immediately. Brake fluid quickly damages synthetic resin or rubber hoses.

- Park the vehicle on a level surface.
- Open the hood.
- Check to see that the brake fluid level is between the [MAX] and [MIN] marks.
- If it is below the [MIN] mark, add brake fluid to the [MAX] mark.

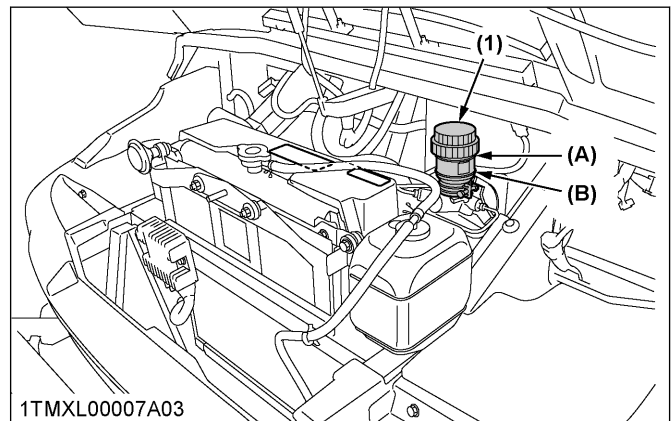

(1) Oil tank (A) [MAX] (B) [MIN]

10. Checking brake pedal

WARNING

To avoid serious injury or death:

- Stop the engine and chock the wheels before checking brake pedal.

- Inspect the brake pedals for free travel, and smooth operation.

- Adjust if incorrect measurement is found: (See Checking brake pedal on page 79.)

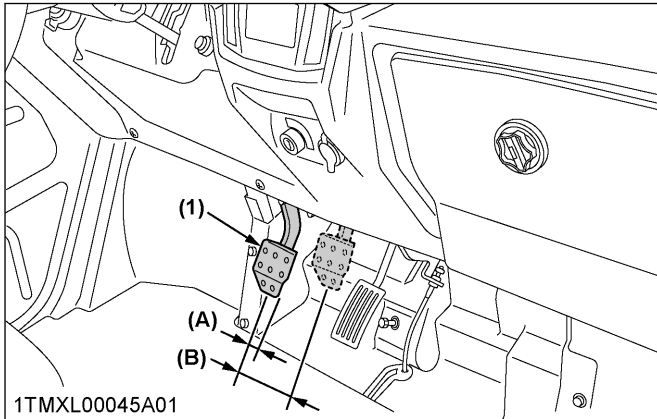

1TMXL00045A01

(1) Brake pedal

(A) "FREE TRAVEL"

(B) "PEDAL STROKE"

11. Checking parking brake

Pull the parking brake lever to apply the brakes. With the key switch at "ON" position, the parking brake indicator on the instrument panel lights up. To release the brakes, push the button at the tip of the parking brake lever and tilt the lever down.

NOTE :

- Make sure the parking brake warning lamp (P) on the Easy Checker™ goes off when parking brake lever is down.

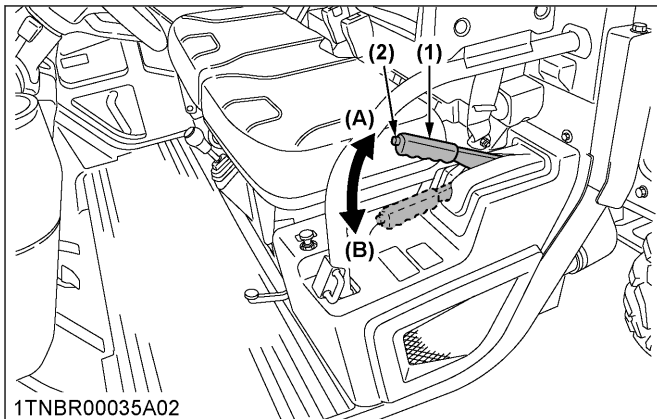

1TNBR00035A02

(1) Parking brake lever

(A) "PULL"

(2) Release button

(B) "RELEASE"

12. Checking Easy Checker™

- Inspect the instrument panel for broken Easy Checker™ lamps.
- Consult your local KUBOTA Dealer if broken.

13. Checking head light, and so on

- Inspect the lights for broken bulbs and lenses.

- Replace if broken.

14. Checking seat belt, ROPS and door latch

- Always check condition of the seat belts and ROPS before operating the vehicle.
- Replace if damaged.

15. Checking joint boot

- Check to see if the joint boots are not damaged. See the following figures.

2. If the joint boots are cut, cracked, or show signs of deterioration, consult your local KUBOTA Dealer.

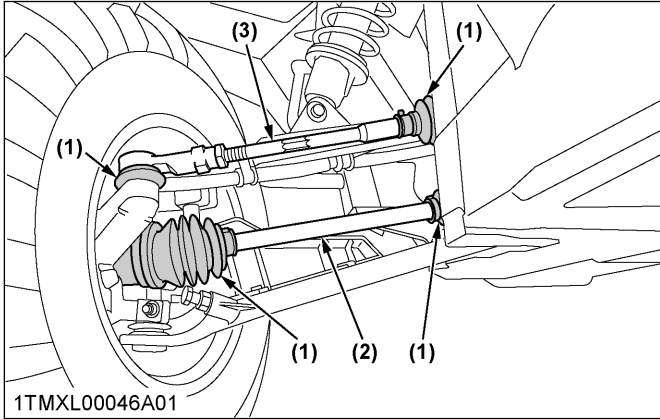

- (1) Joint boot
- (2) Front drive shaft
- (3) Tie rod

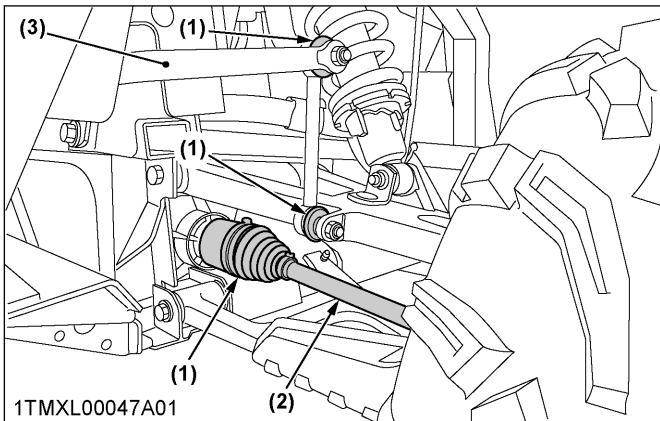

- (1) Joint boot
- (2) Front drive shaft
- (3) Front stabilizer

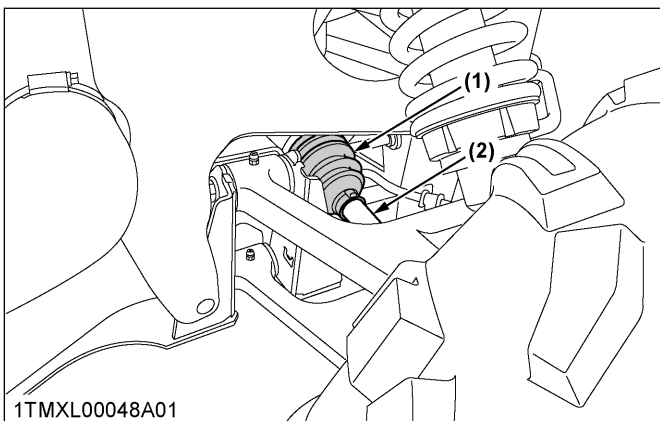

- (1) Joint boot
- (2) Rear drive shaft

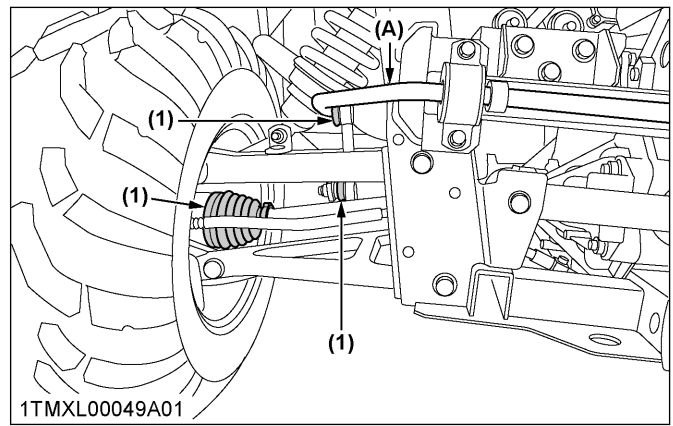

- (1) Joint boot
- (A) Rear stabilizer

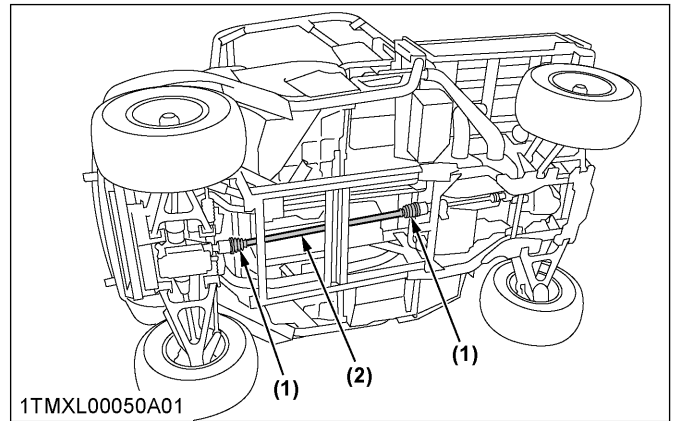

- (1) Joint boot
- (2) Drive shaft

16. Checking tire inflation pressure

Though the tire pressure is factory-set to the prescribed level, it naturally drops slowly in the course of time. Thus, check it everyday and inflate as necessary.

Cargo bed load condition	Tire		Inflation pressure
0 to less than 550 lbs. (0 to less than 250 kg)	25 × 10 - 12 HDWS ATV	Front	120 kPa 1.2 kgf/cm ² 17 psi
		Rear	120 kPa 1.2 kgf/cm ² 17 psi
550 lbs. or more (250 kg or more)	25 × 10 - 12 HDWS ATV	Front	120 kPa 1.2 kgf/cm ² 17 psi
		Rear	170 kPa 1.7 kgf/cm ² 24 psi

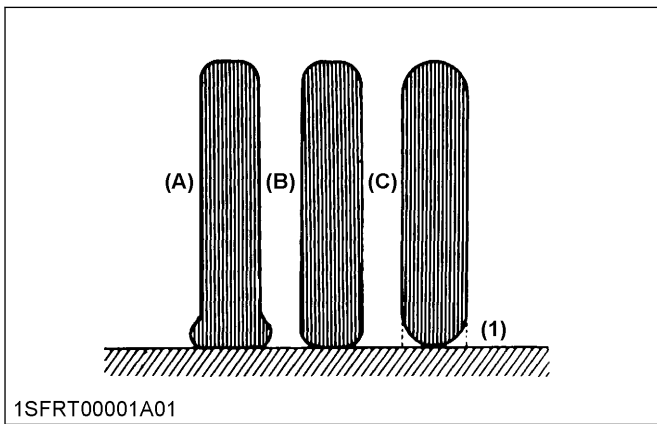

(1) Ground
 (A) "INSUFFICIENT"
 (B) "NORMAL"
 (C) "EXCESSIVE"

17. Checking tire

1. Check to see if tires are not damaged.
2. If the tires are cracked, bulged, or cut, or they are worn out, replace or repair them at once.

Tire tread depth

Always replace the tires when the tread depth is worn to minimum allowable.

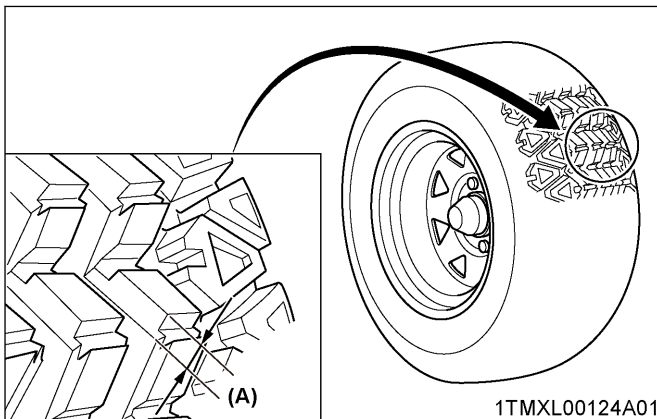

(A) Minimum allowable tread depth 5 mm (0.2 in.)

EVERY 50 HOURS OR 1500 KM

Perform the following servicing once every 50 hours or 1500 km, whichever comes first.

1. Checking engine start system

WARNING

To avoid serious injury or death:

- Do not allow anyone near the vehicle while testing.
- If the vehicle does not pass the test, do not operate the vehicle.

Preparation before testing.

1. Place all control levers in the "NEUTRAL" position.
2. Set the parking brake and stop the engine.

Test: Range gear shift lever safety switch

1. Sit on the operator's seat.
2. Shift the range gear shift lever to [H] position.
3. Return the speed control pedal to the "NEUTRAL" position.
4. Turn the key to "START" position.
5. The engine must not crank.
6. Repeat the step 2 to 5 with the range gear shift lever at [L] and [R] each position.
7. If it cranks, consult your local KUBOTA Dealer for service.

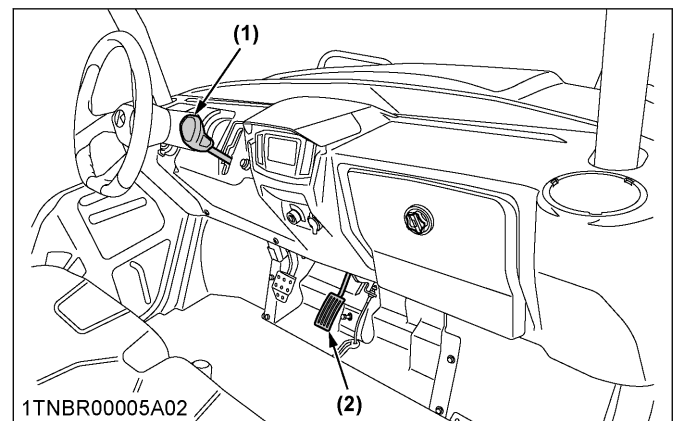

(1) Range gear shift lever
 (2) Speed control pedal

2. Greasing

Apply a small amount of multi-purpose grease to the following points every 50 hours: If you operate the vehicle in extremely wet and muddy conditions, lubricate grease fittings daily.

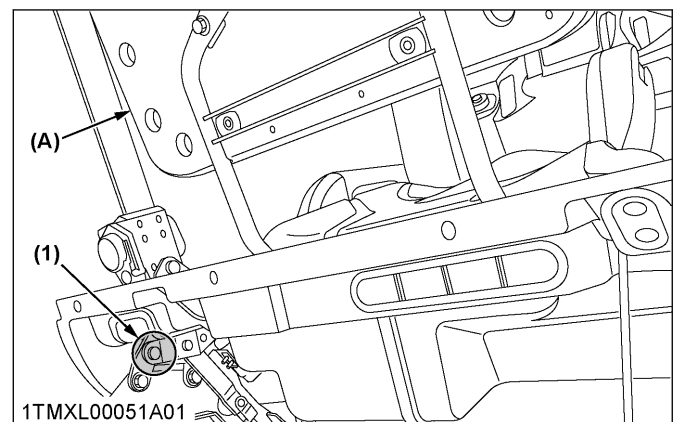

(1) Parking brake lever (spray type grease) (A) Seat

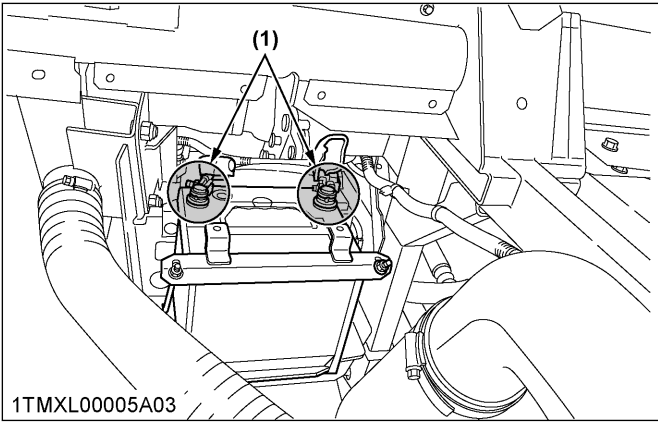

(1) Battery terminals (For this access, see Charging the battery on page 74.)

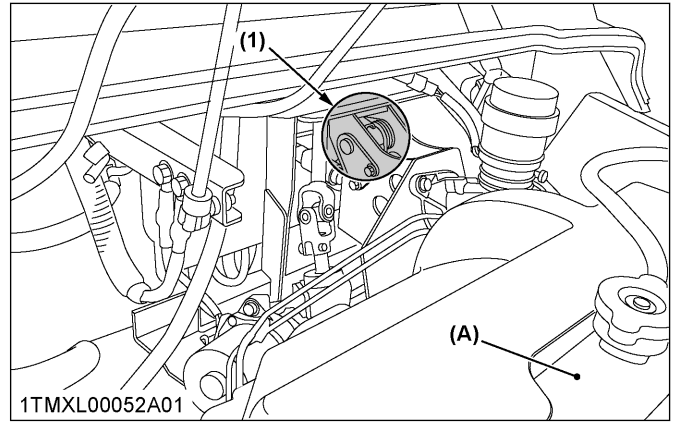

(1) Range gear shift lever pivot (A) Radiator (spray type grease)

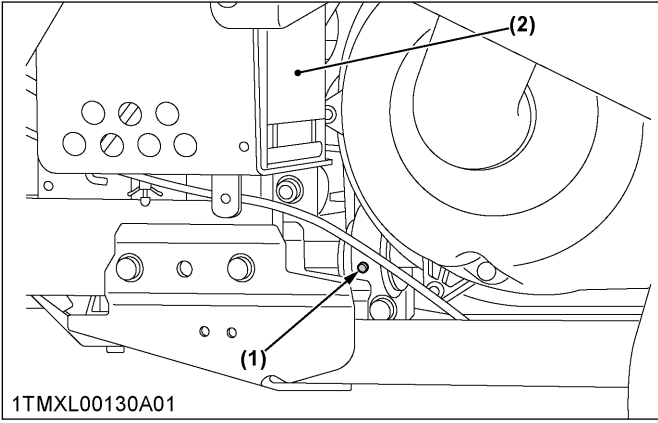

(1) Pillow block bearing
(2) Battery

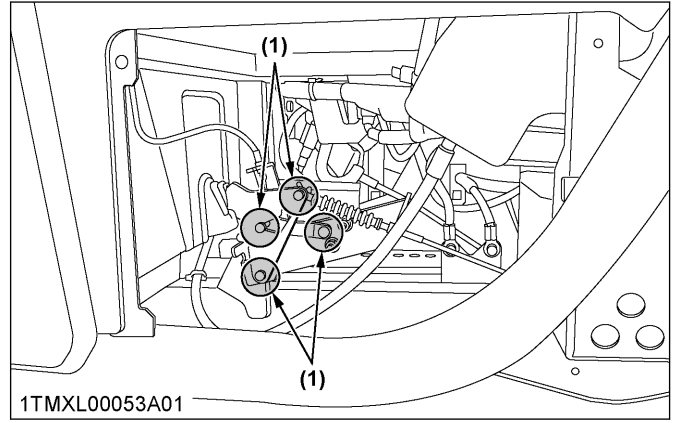

(1) Differential lock pedal (spray type grease)

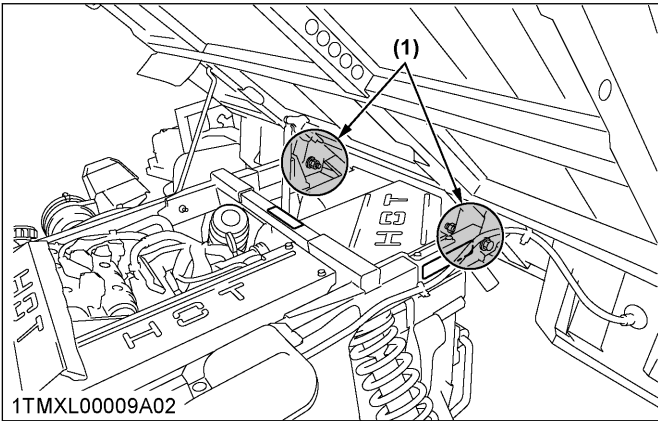

(1) Cargo bed pivot (spray type grease)

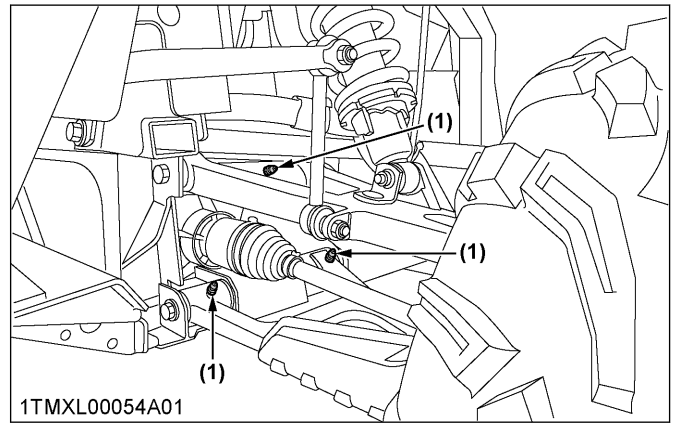

(1) Front A-ARM (grease fitting) (on both sides)

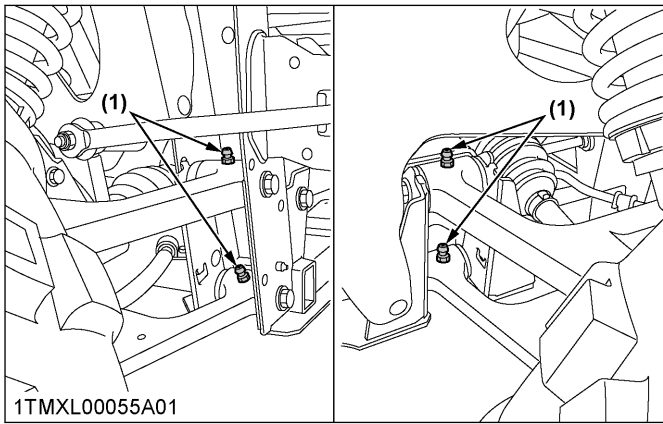

(1) Rear A-ARM (grease fitting) (on both sides)

EVERY 100 HOURS OR 3000 KM

Perform the following servicing once every 100 hours or 3000 km, whichever comes first.

1. Checking wheel fastener torque

WARNING

To avoid serious injury or death:

- Never operate vehicle with a loose wheel bolts.
- Any time bolts are loosened, retighten to the specified torque.
- Check all bolts frequently and keep them tight.

Check wheel bolts regularly especially when new. If they are loose, tighten them as follows.

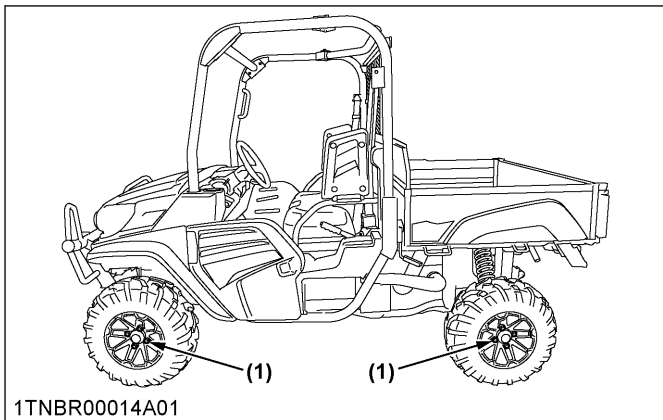

(1) Tightening torque (nuts)

Aluminum wheel, steel wheel: 130 to 150 N·m / 13.3 to 15.2 kgf·m / 95.9 to 110 lbf·ft

2. Checking brake pad wear

WARNING

To avoid serious injury or death:

- The machine can fall or slip from an unsafe device or supports.

- Use a safe lifting device rated for the load to be lifted.
- Lower the vehicle onto jack stands and block the wheels before servicing.

Details regarding “JACK-UP POINT” can be found in a different section.

(See JACK-UP POINT on page 61.)

1. Park the vehicle on a firm, flat and level surface.
2. Raise the vehicle with a safe devise and lower onto the jack or other stable supports. Block the wheels remaining on the ground to prevent the vehicle from moving.
3. Remove the wheel nuts and the tires.

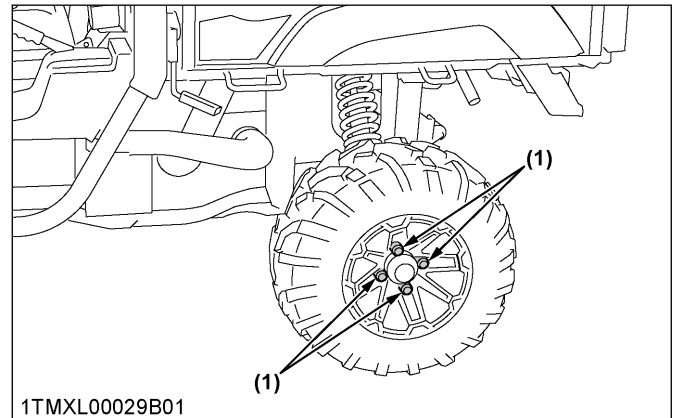

(1) Wheel nuts

4. Check the brake pads for wear or damage.
Check the pad's thickness:
If pad is damaged or its thickness is less than 1 mm (3/64 inch), contact your local KUBOTA Dealer.

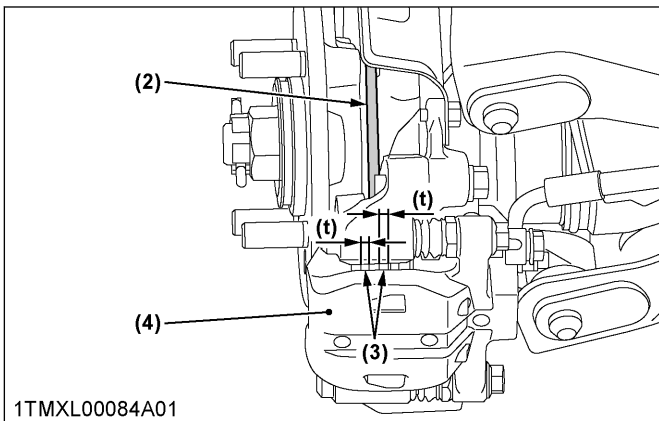
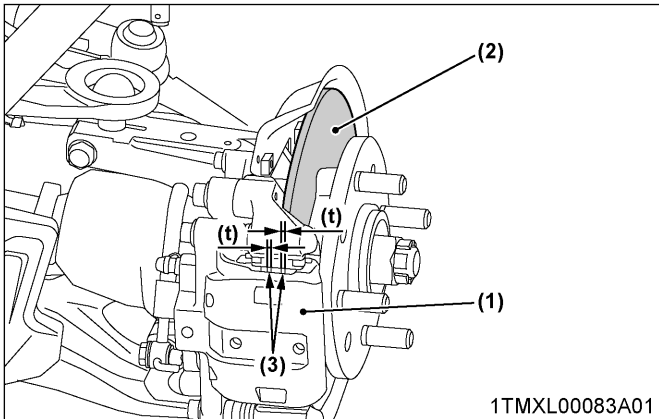

- (1) Front disk brake assy (t) Thickness
(2) Brake disk
(3) Brake pad
(4) Rear disk brake assy

5. Reinstall the tires with the valve stem to the outside.
6. Tighten the wheel nuts evenly in alternating sequence until snug.
7. Lower the vehicle completely to the ground.
8. Tighten the wheel nuts.

Tightening torque (nut)	Aluminum wheel, Steel wheel	130 to 150 N·m 13.3 to 15.2 kgf·m 95.9 to 110 lbf·ft
-------------------------	--------------------------------	--

3. Cleaning air cleaner primary element

1. Remove the air cleaner cover and primary element.

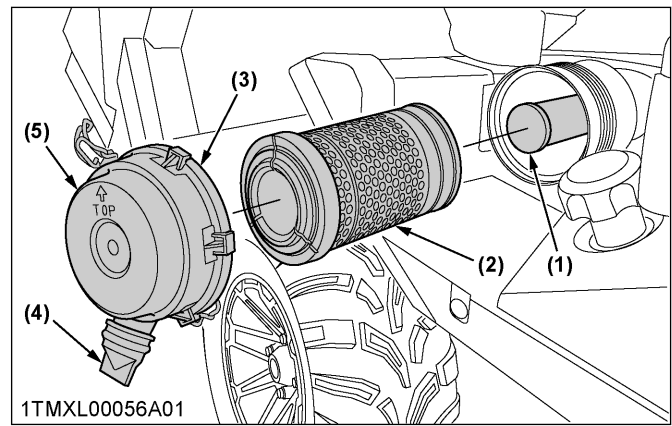

- (1) Secondary (safety) element
(2) Primary element
(3) Rubber seal
(4) Evacuator valve
(5) Cover

2. Clean the primary element:
 - a. When dry dust adheres to the element, blow compressed air from the inside, turning the element. Pressure of compressed air must be under 205 kPa (2.1 kgf/cm², 30 psi).
 - b. When carbon or oil adheres to the element, replace the element with a new one even if it has not been used for 1 year.
Do not blow material onto yourself. Wear appropriate protective gear when cleaning element.
3. Replace the primary element:
Once yearly or 1000 hours whichever comes first.

NOTE :

- Check to see if the evacuator valve is blocked with dust.
- Check the rubber seal. Replace if damaged.

IMPORTANT :

- The air cleaner uses a dry element, never apply oil.
- Do not run the engine with filter element removed.
- Refit the cover with the arrow (on the rear of cover) upright. If the cover is not properly replaced, the evacuator valve will not function and dust will adhere to the element.
- Do not touch the secondary element except in cases where replacing is required.

Evacuator valve

Open the evacuator valve once a week under ordinary conditions - or daily when used in a dusty place - to get rid of large particles of dust and dirt.

4. Changing engine oil

⚠ WARNING

To avoid serious injury or death:

- Stop the engine before changing the oil.
- Allow engine to cool down sufficiently, oil can be hot and can burn.

IMPORTANT :

- Clean the area around dipstick and oil inlet before removing or loosening them, and be careful not to allow the dust go into the engine.
- When using an oil of different maker or viscosity from the previous one, remove all of the old oil. Never mix 2 different types of oil.
- If oil level is low, do not run engine.
- To Avoid Damage! Vehicles subjected to the following extreme operations and/or conditions must be inspected and serviced more frequently.
 - Frequent or prolonged operations in dusty environments.
 - Prolonged low speed operations.
 - Extended idle time.
 - Frequent short trips which do not let the engine warm up (especially in cold weather).

1. Park the vehicle on a level surface.
2. Raise the cargo bed and mount the safety support.
3. Stop the engine.
4. To drain the used oil, remove the drain plug at the bottom of the engine and completely drain the oil into an oil pan. All the used oil can be drained out easily when the engine is still warm.
5. After draining, reinstall the drain plug.

Oil capacity	Filter exchanged: 3.8 L (4.0 U.S.qts.) Filter non-exchanged: 3.6 L (3.8 U.S.qts.)
--------------	--

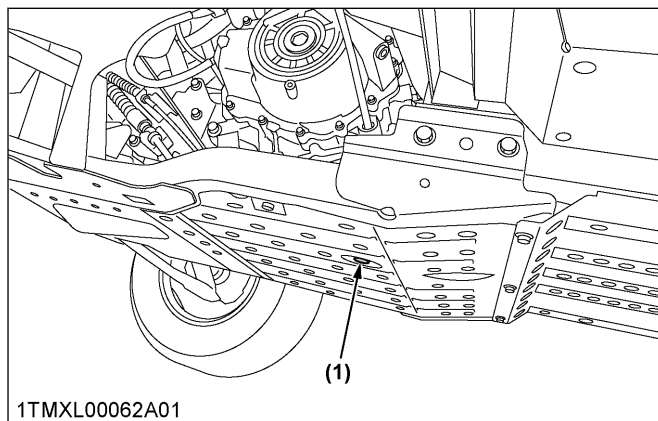

(1) Drain plug

Tightening torque (bolt)	20.0 to 23.0 N·m 2.04 to 2.34 kgf·m 14.8 to 16.9 lbf·ft
--------------------------	---

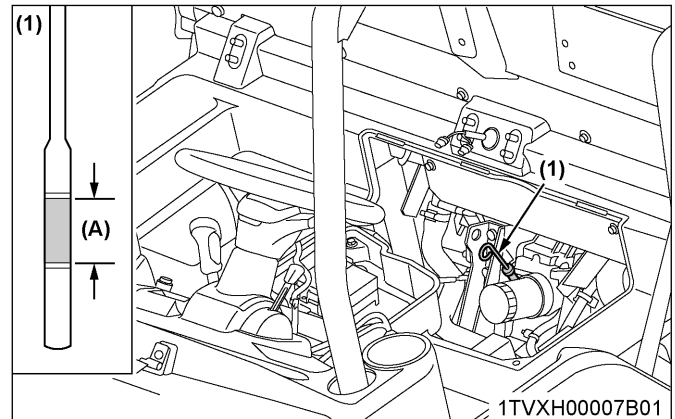

(1) Dipstick

(A) Oil level is acceptable within this range.

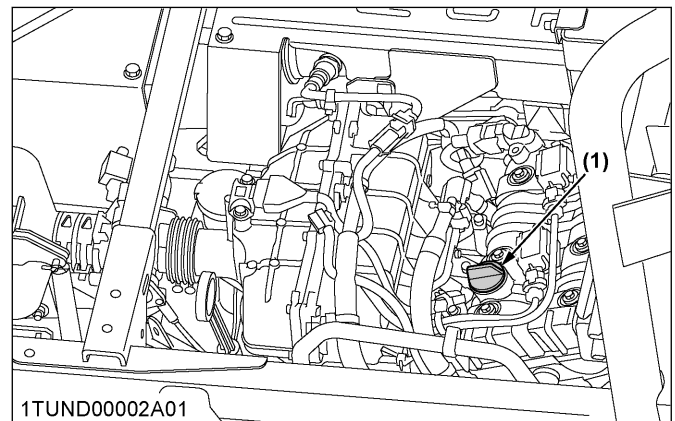

(1) Oil inlet

6. Fill with the new oil up to the upper line on the dipstick.
(See LUBRICANTS, FUEL AND COOLANT on page 58.)
7. Properly dispose of used oil.

5. Checking fuel pump filter

1. Park the vehicle on a flat surface.
2. Start the engine.
3. Set the range gear shift lever to the "NEUTRAL" position.
4. Push down on the speed control pedal for higher speed.

- If the engine rotation does not increase easily or anything seems unusual, consult your KUBOTA Dealer.
The fuel pump filter may be clogged.

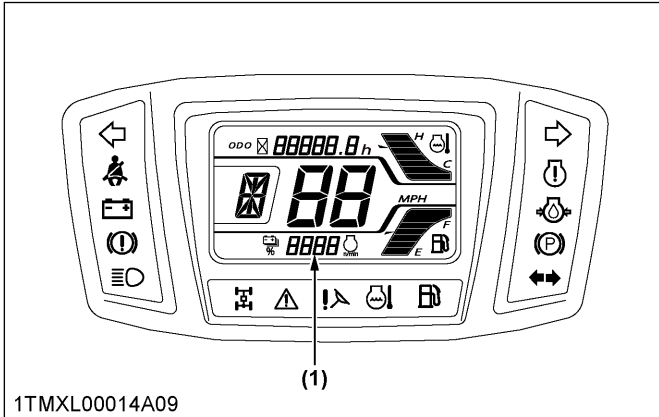

1TMXL00014A09

(1) Tachometer

6. Checking battery condition

! DANGER

To avoid the possibility of battery explosion:
For the refillable type battery, follow these instructions.

- Do not use or charge the refillable type battery if the fluid level is below the [LOWER] (lower limit level) mark. Otherwise, the battery component parts may prematurely deteriorate, which may shorten the battery's service life or cause an explosion. Check the fluid level regularly and add distilled water as required so that the fluid level is between the [UPPER] and [LOWER] levels.
- When the battery is being activated, hydrogen and oxygen gases in the battery are extremely explosive. Keep open sparks and flames away from the battery at all times, especially when charging the battery.
Read and heed the battery safety label.

! WARNING

To avoid serious injury or death:

- Batteries, battery posts, terminals and related accessories contain lead and lead compounds, and other chemicals known to the State of California to cause cancer and birth defects or other reproductive harm. Wash hands after handling.
- Never remove the battery cap while the engine is running.
- Keep electrolyte away from eyes, hands and clothes. If you are splattered with it, wash it away completely with water immediately and seek medical attention.

- Keep open sparks and flames away from the battery at all times. Hydrogen gas mixed with oxygen becomes very explosive.
- Wear eye protection and rubber gloves when working around battery.

NOTE :

- The factory-installed battery is a non-refillable type.
If the battery is weak, charge the battery or replace it with a new one.

IMPORTANT :

- Mishandling the battery shortens the service life and adds to maintenance costs.
The original battery is maintenance free, but needs some servicing.
If the battery is weak, the engine will be difficult to start and the lights will be dim. It is important to check the battery periodically.
- When exchanging an old battery for a new one, use battery of equal specification in the following table.

Battery type	Volts (V)	Reserve capacity (min)	Cold cranking amps	Capacity at 20 hrs (A. H.)
SMF 26-560	12	86	560	56

(For non-accessible maintenance-free type batteries.)
Maintenance-free, non-accessible batteries are designed to eliminate the need to add water. Yet the volume of electrolyte above plates may eventually become depleted due to abnormal conditions such as high heat or improper regulator setting. Use a voltmeter to check the state of charge.
(See the following reference chart to determine if charging is necessary.)

Battery voltage	Reference state of charge
12.6	100 % (full charge)
12.4	75 %
12.2	50 %
12.0	25 %
11.8	0 %

6.1 Charging the battery

! DANGER

To avoid serious injury or death:

- When the battery is being activated, hydrogen and oxygen gases in the battery are extremely explosive. Keep open sparks and flames away from the battery at all times, especially when charging the battery.

Read and heed the battery safety label.

⚠ WARNING

To avoid serious injury or death:

- When disconnecting the cable from the battery, start with the negative terminal first. When connecting the cable to the battery, start with the positive terminal first.
- If the battery cable is loose, it can cause sparks or an explosion. Tighten the battery terminals securely and make sure the covers are installed on both the negative and positive terminals.
- Never check battery charge by placing a metal object across the posts. Use a voltmeter or hydrometer.

1. Park the vehicle on a flat surface.
2. Stop the engine.
3. Remove the push rivet of the sheet and flip up the sheet.

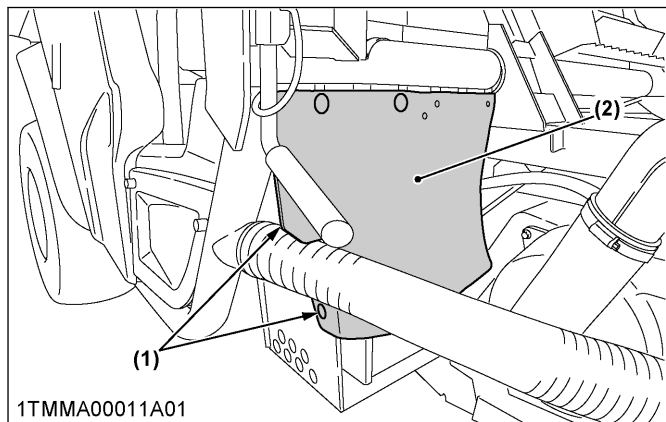

(1) Push rivet
(2) Sheet

NOTE :

- To remove the push rivet:
 1. Push the pin to unlock.
 2. Remove the push rivet.
- To install the push rivet:
 3. Push the pin to ready to install.
 4. Install the push rivet into the hole.
 5. Push the pin to lock.

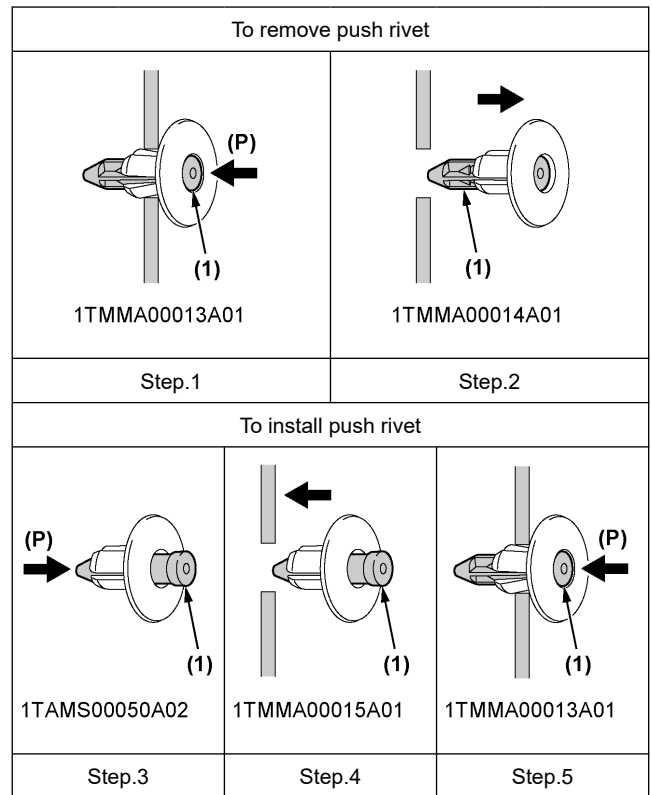

(1) Pin

(P) "PUSH"

4. Remove the battery cover.

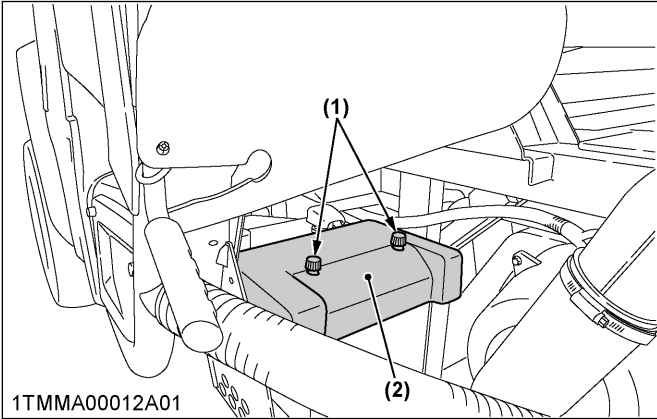

(1) Screw
(2) Battery cover

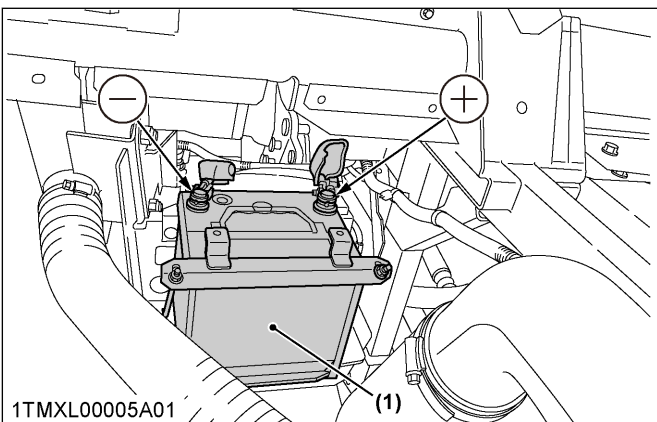

(1) Battery

5. To slow charge the battery, connect the battery positive terminal to the charger positive terminal and the negative to the negative, then recharge in the standard fashion.
6. A boost charge is only for emergencies. It will partially charge the battery at a high rate and in a short time. When using a boost-charged battery, it is necessary to recharge the battery as early as possible. Failure to do this will shorten the battery's service life.
7. When exchanging an old battery for a new one, use battery of equal specification.

6.2 Directions for battery storage

1. When storing the vehicle for a long period, remove the battery from vehicle, adjust the electrolyte to the proper level (refillable type only) and store in a dry place out of direct sunlight.
2. The battery self-discharges while it is stored. Recharge it once every 3 months in hot seasons and once every 6 months in cold seasons.

7. Adjusting toe-in

Proper toe-in	5 to 15 mm (0.2 to 0.59 in.)
---------------	------------------------------

1. Park vehicle on a flat place.
2. Turn steering wheel so front wheels are in the straight ahead position.
3. Lock the parking brake and stop the engine.
4. Measure distance between tire treads at front of tire, at hub height.
5. Measure distance between tire treads at rear of tire, at hub height.
6. Front distance should be shorter than rear distance. If not, adjust tie rod length.

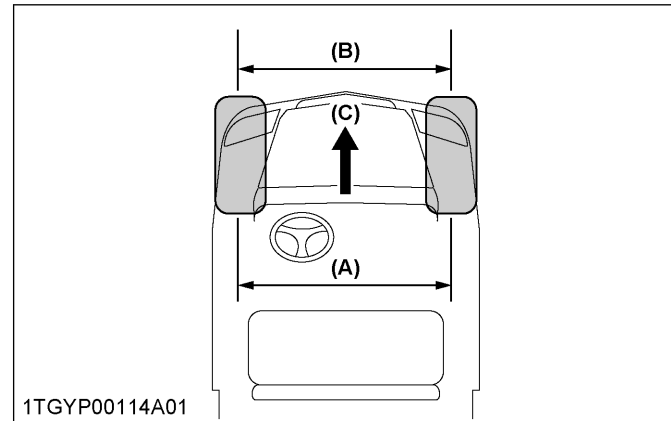

(A) Wheel - to - wheel distance at rear
(B) Wheel - to - wheel distance at front
(C) "FRONT"

Adjusting procedures

1. Loosen the lock nut and turn the tie rod to adjust the rod length until the proper toe-in measurement is obtained.
2. Retighten the lock nut.

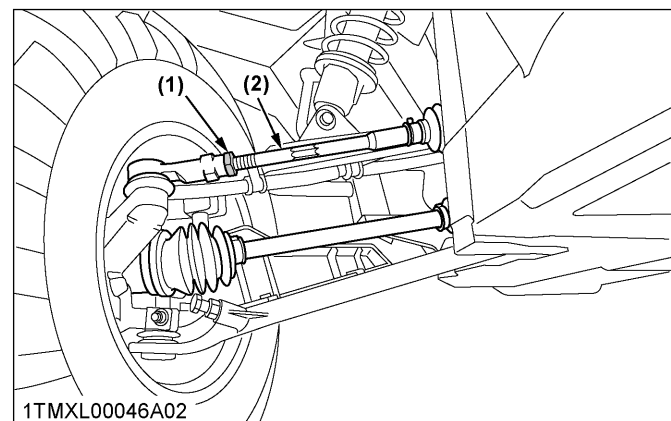

(1) Lock nut
(2) Tie-rod

IMPORTANT :

- Keep the length of the left and right tie-rod equal.

NOTE :

- Tightening torque (lock nut):

74 to 84 N·m, 7.6 to 8.5 kgf·m, 55 to 61 lbf·ft

8. Cleaning spark arrester

WARNING

To avoid serious injury or death:

- After operating the engine, do not touch the muffler, exhaust pipe, or spark arrester until they have had sufficient time to cool.
- A spark arrester that has been improperly installed can emit sparks that may pose the risk of fire. Make sure the spark arrester and the muffler are installed securely.
- Hot carbon particles may be released while cleaning the spark arrester, causing a fire which may lead to serious burns or injury. Do not operate the engine near flammable materials while the spark arrester is removed.

This screen type spark arrester was examined, tested, and qualified in accordance with the USDA Forest Service Standard 5100-1d.

Maintenance and cleanout procedure

The screen type spark arrester should be removed, cleaned, and inspected after every 100 hours of use.

1. The spark arrester is installed to the muffler with bolts.
2. Loosen the bolts and remove the spark arrester.
3. Shake particles off the screen and lightly clean the screen with a wire brush. Soak in solvent and clean with a wire brush again if necessary.
4. If any breakage is found in the screen or weldment, replace the assembly with a new one.
5. Reinstall the spark arrester to the muffler and tighten the bolts.

Tightening torque (bolt)	10 N·m 1.0 kgf·m 7.4 lbf·ft
--------------------------	-----------------------------------

IMPORTANT :

- USDA approval requires clearance between spark arrester sleeve and exhaust pipe to be no larger than 0.023" (0.584 mm).

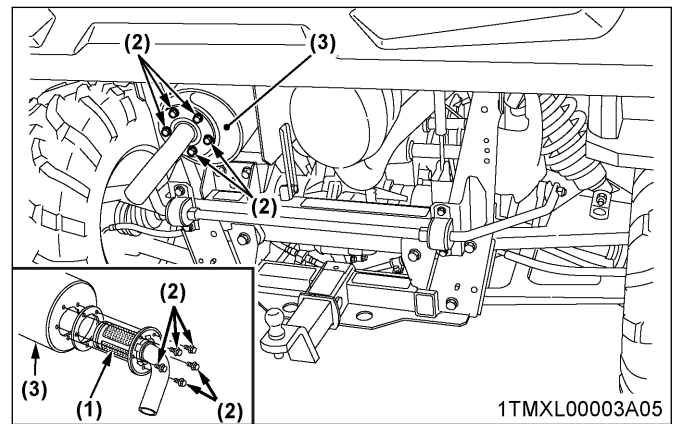

- (1) Spark arrester
(2) Bolt
(3) Muffler

1TMXL00003A05

9. Checking exhaust system

Check exhaust system parts (muffler, pipe, gasket) for failures such as cracks and deformation. If necessary, replace faulty part. If you do not know the failure, consult your local KUBOTA Dealer for this service.

10. Checking CVT belt

Consult your local KUBOTA Dealer for this service.

Have your CVT belt checked when:

- Rubber burning smell.
- Engine speed increases even at the same vehicle speed.

IMPORTANT :

- Avoid the hard use method shown below so that the CVT belt does not get premature wear and damage:
 - When travelling in a place with extremely dusty conditions.
 - When driving continues while belt slip (the engine speed increases even at the same vehicle speed).
 - When going deeper into mud or water than recommended.
 - To climb, to carry a heavy load, to tow, to use the high range in these cases.
 - When exceeding the maximum load capacity or tow load.
 - When extremely cold, loading the engine without warmup.

11. Checking the transmission gear shift switch

1. Confirm that the range gear shift position is properly displayed on the LCD panel.

- If the range gear shift position is not displayed right, such as the displayed range gear shift position does not match the actual position, consult your local KUBOTA Dealer.

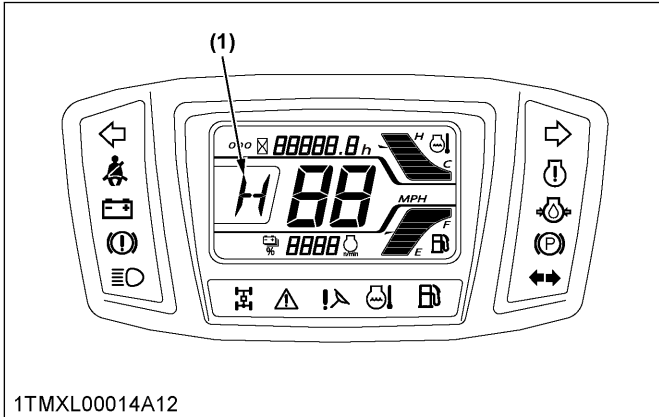

(1) Range gear shift position

12. Checking carbon canister air filter (California only)

- Remove the push rivets and rubber sheet.

NOTE :

- To remove the push rivet:
 - Push the pin to unlock.
 - Remove the push rivet.
- To install the push rivet:
 - Push the pin to ready to install.
 - Install the push rivet into the hole.
 - Push the pin to lock.

See the following figures.

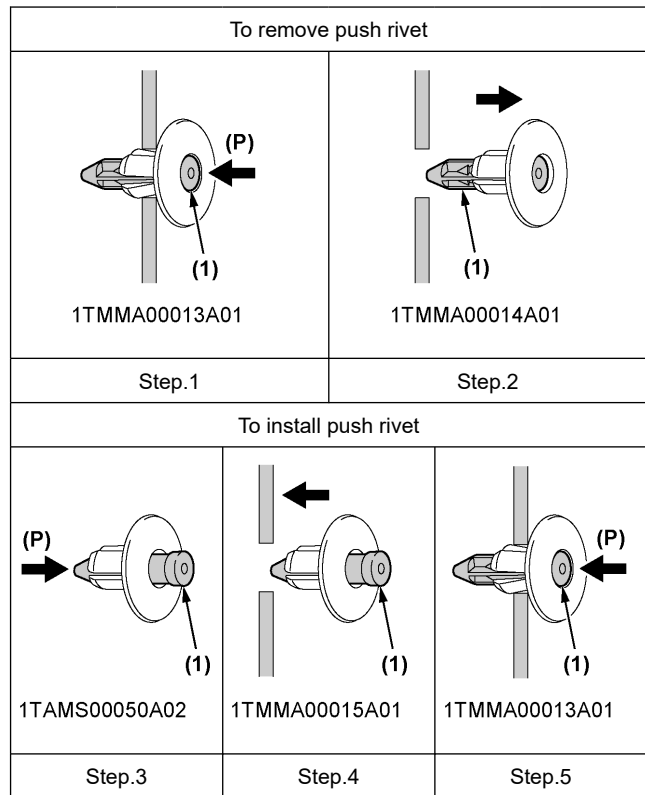

(1) Pin

(P) "PUSH"

- Check to see if the carbon canister air filter is worn out, damaged or dirty.
 - If air filter is worn out, damaged or too dirty, consult your local KUBOTA Dealer for this service.
- If you have any questions, contact your local KUBOTA Dealer.

NOTE :

- Operating in dusty condition may require more frequent maintenance than above.

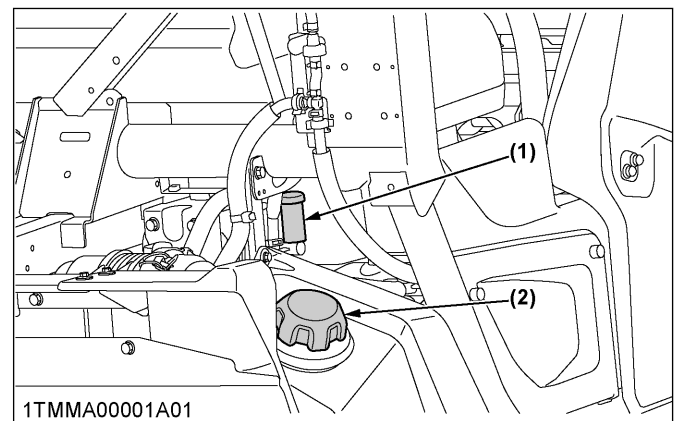

(1) Carbon canister air filter
(2) Fuel tank cap

EVERY 200 HOURS OR 3000 KM

1. Checking the suspension arm bushings

1. Inspect the suspension arm bushings.
2. Replace the bushings or the pins, if necessary.
Contact your local KUBOTA Dealer to replace.

EVERY 200 HOURS OR 6000 KM

Perform the following servicing once every 200 hours or 6000 km, whichever comes first.

1. Checking brake pedal

WARNING

To avoid serious injury or death:

- Stop the engine and chock the wheels before checking brake pedal.
- If movement is outside of the specifications, contact your local KUBOTA Dealer for adjusting the brake.

Checking the brake pedal free travel

Proper brake pedal free travel	4 to 18 mm (0.2 to 0.7 in.) on the pedal
--------------------------------	--

1. Release the parking brake.
2. Slightly depress the brake pedal and measure free travel at the top of the pedal stroke.
3. If brake pedal free travel is outside of the specifications, contact your local KUBOTA Dealer for adjusting the brake.

Checking the brake pedal stroke

Pedal stroke	Less than 150 mm (5.9 in.) on the pedal
--------------	---

1. Release the parking brake.
2. Step on the pedal and measure the pedal stroke.
3. If brake pedal stroke is outside of the specifications, contact your local KUBOTA Dealer for adjusting the brake.

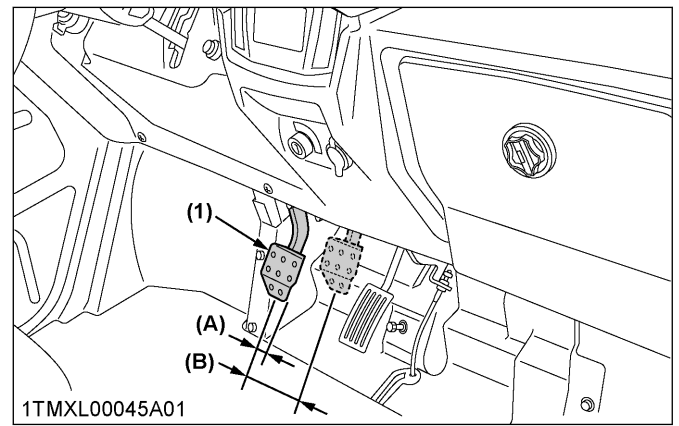

(1) Brake pedal

(A) "FREE TRAVEL"

(B) "PEDAL STROKE"

2. Checking brake light

1. Park the vehicle on a flat surface.
2. Step on the brake pedal to check if the brake light comes on.
3. If it does not, check the bulb or brake light.

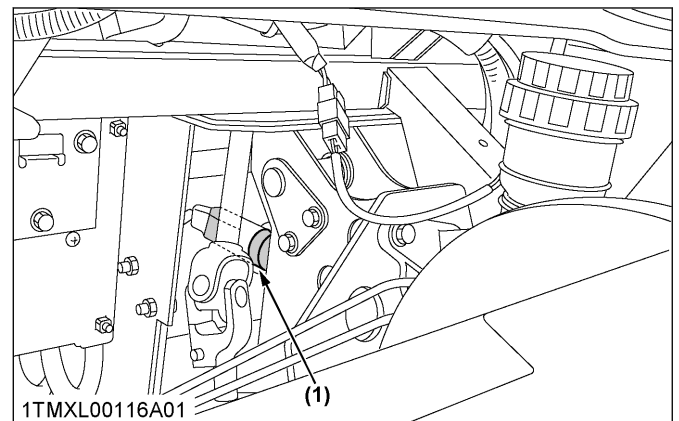

(1) Brake light

3. Adjusting parking brake

Proper parking brake lever free play range	1 notch
--	---------

Adjusting procedure

1. Park the vehicle on a flat surface.
2. Stop the engine and remove the key.
3. Release the parking brake.
4. Loosen the lock nuts.
5. Adjust the cable wire length.
6. Pull the parking brake lever 1 notch and make sure the vehicle does not roll easily by hand.
7. Release the parking brake and make sure the vehicle rolls easily by hand.

8. Tighten the lock nuts securely.

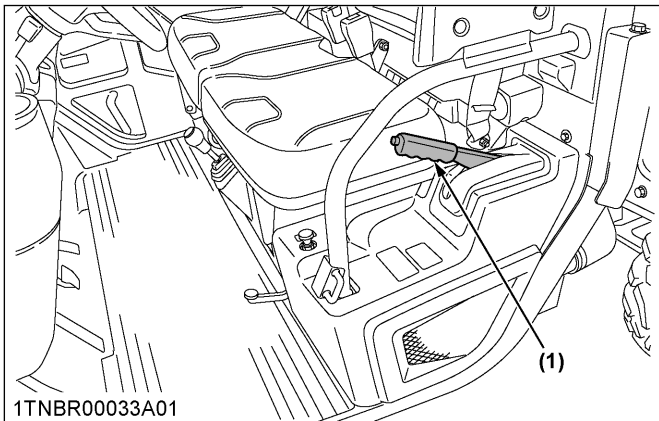

(1) Parking brake lever

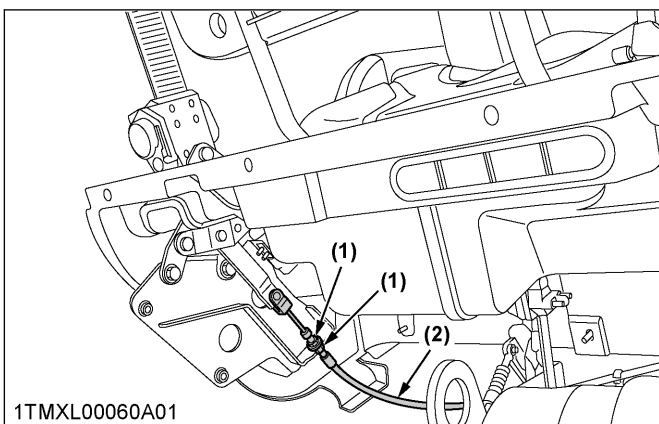

(1) Lock nut
(2) Cable wire

4. Replacing engine oil filter

WARNING

To avoid serious injury or death:

- Stop the engine before changing the oil filter.
- Allow engine to cool down sufficiently, oil can be hot and can burn.

IMPORTANT :

- To prevent serious damage to the engine, use only a KUBOTA genuine filter.

1. Park the vehicle on a flat surface.
2. Stop the engine.
3. Remove the rear skid plate.
4. Remove the oil filter.
5. Put a film of clean engine oil on the rubber seal of the new filter.
6. Tighten the filter quickly until it contacts the mounting surface. Tighten the filter by hand an additional 1/2 turn only.
7. After the new filter has been replaced, the engine oil normally decreases a little. Make sure that the

engine oil does not leak through the seal and check the oil level on the dipstick. Then, replenish the engine oil up to the prescribed level.

8. Properly dispose of used filter.

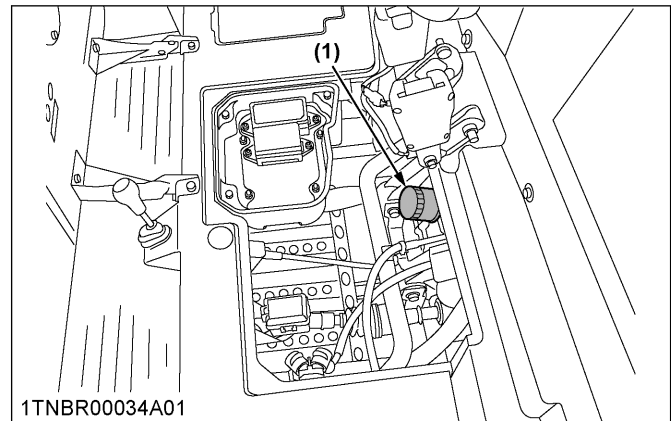

(1) Engine oil filter

5. Checking spark plug condition and gap

CAUTION

To avoid personal injury:

- Wear safety goggles when using pressurized air.

Remove the spark plugs, check condition, and reset the gap or replace with new plugs as necessary.

1. Raise the cargo bed.
2. Push the safety support into the latch slot to lock when the cargo is fully raised.
3. Before removing spark plugs, clean the area around the base of the plug to keep dirt and debris out of the engine.
4. Remove the bolt to remove the spark plug wires from spark plugs.

- Use a spark plug wrench to remove the spark plugs.

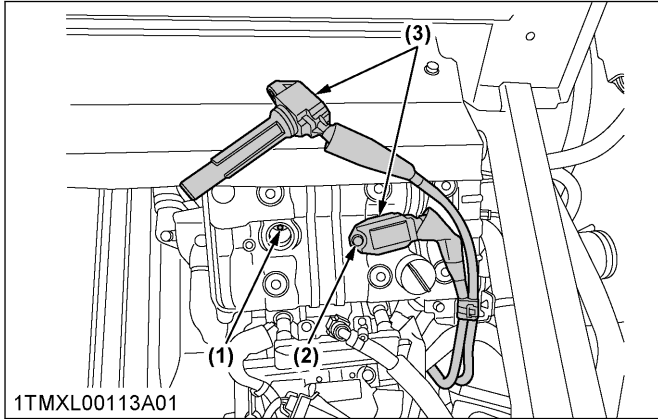

1TMXL00113A01

- (1) Spark plug
- (2) Bolt
- (3) Spark plug wire

- Remove the spark plugs. Inspect them for cracked porcelain, pitted electrodes or other wear and damage. Replace spark plugs if necessary.

NOTE :

- Do not clean the spark plug in a machine using abrasive grit. Some grit could remain in the spark plug and enter the engine causing extensive wear and damage.

Recommended spark plug	NGK MR7J-9
------------------------	------------

- Check the gap using a wire feeler gauge. Adjust the gap from 0.8 to 1.1 mm (0.031 to 0.043 in.) by carefully bending the ground electrode.

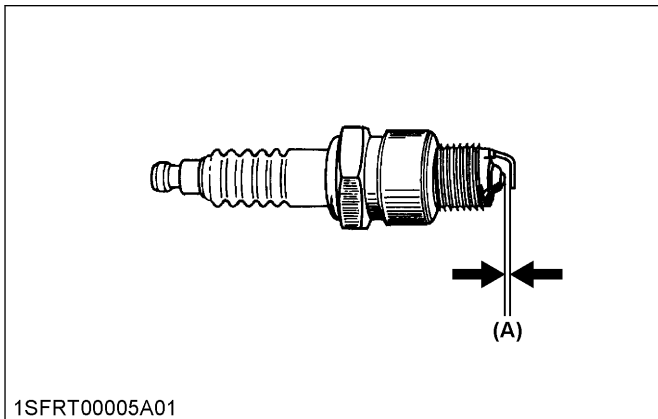

1SFRT00005A01

- (A) from 0.8 to 1.1 mm (0.031 to 0.043 in.)

- Reinstall the spark plug into the cylinder head. Install the spark plug wires to spark plug.

Retightening torque	10 to 12 N·m (7.4 to 8.9 lbf·ft)
Spark plug socket size	16 mm

IMPORTANT :

- Do not overtighten spark plugs. Engine and spark plugs can be damaged.
- Do not apply anti-seize lubricant over spark plug threads.

- Release the safety support from the latch slot.
- Slowly lower the cargo bed into the frame.

6. Checking engine valve clearance

If you do not have the proper tools and/or are not mechanically proficient, consult your local KUBOTA Dealer for this service.

EVERY 400 HOURS OR 12000 KM

Perform the following servicing once every 400 hours or 12000 km, whichever comes first.

1. Changing transmission fluid

⚠ WARNING

To avoid serious injury or death:

- Stop the engine before changing the oil.
- Allow engine to cool down sufficiently, oil can be hot and can burn.

- Park the vehicle on a level surface.
- Raise the cargo bed and mount the safety support.
- To drain the used oil, remove the drain plug at the bottom of the transmission case and drain the oil completely into the oil pan.

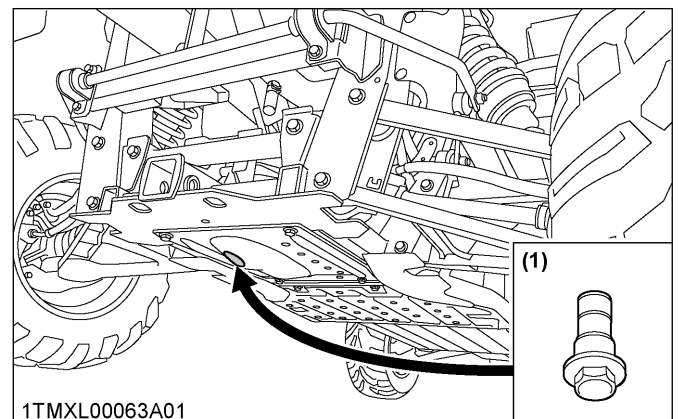

1TMXL00063A01

- (1) Drain plug

- After draining, reinstall the drain plug.

- Fill with the new fluid within the range as shown in the figure.
(See LUBRICANTS, FUEL AND COOLANT on page 58.)

Oil capacity	2.5 L (2.6 U.S.qts.)
--------------	----------------------

- Properly dispose of used oil.

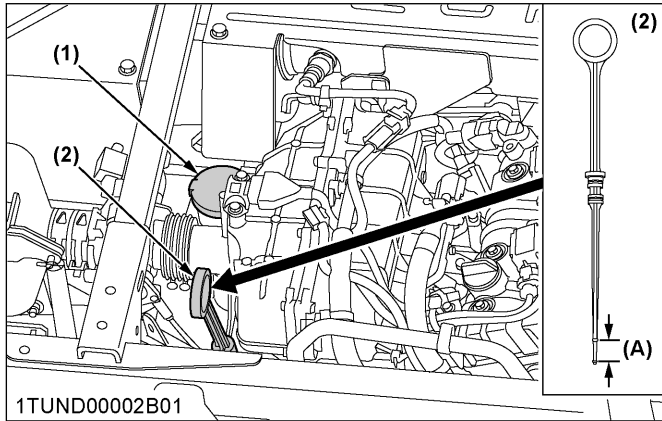

- (1) Oil inlet
(2) Dipstick
(A) Oil level is acceptable within this range.

Cleaning drain plug

Remove the drain plug and clean off metal filings.

NOTE :

- Do not operate the vehicle immediately after changing the transmission fluid.
Run the engine at medium speed for a few minutes to prevent damage to the transmission.

2. Changing front axle case oil

Oil capacity	0.6 L (0.6 U.S.qts.)
--------------	----------------------

(See the first table of LUBRICANTS, FUEL AND COOLANT on page 58.)

- Park the vehicle on a level surface.
- Turn over the rubber sheet.
- To drain the used oil, remove the drain plug and the filling plug at the front axle case and drain the oil completely into the oil pan.
- After draining, reinstall the drain plug.
- Fill with the new prescribed oil up to the upper line on the dipstick.
- After filling, reinstall the filling plug.
- Properly dispose of used oil.

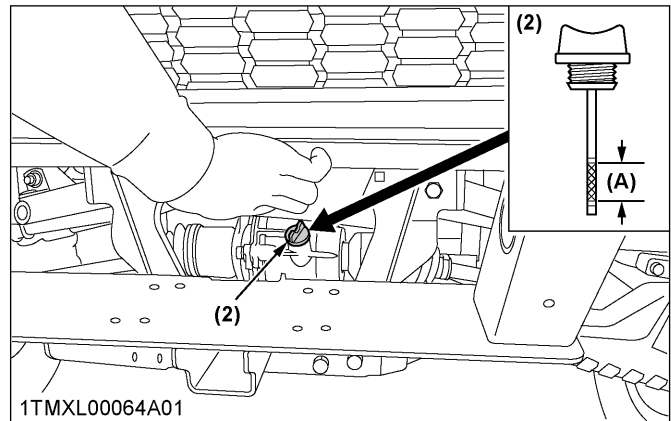
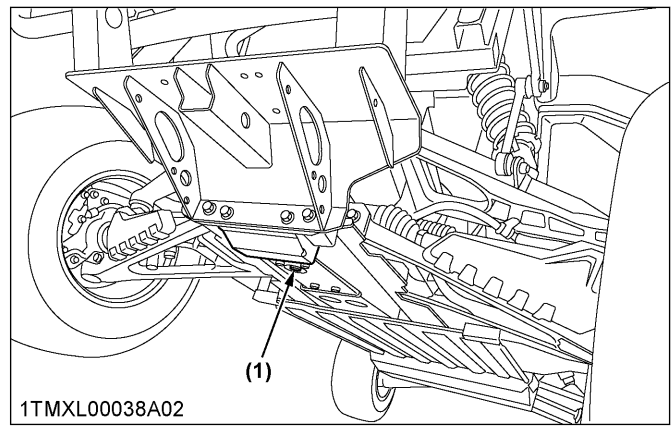

- (1) Drain plug
(2) Filling plug with dipstick
(A) Oil level is acceptable within this range.

EVERY 500 HOURS OR 15000 KM

Perform the following servicing once every 500 hours or 15000 km, whichever comes first.

1. Checking purge valve (California only)

- Park the vehicle on a level surface.
- Set the range gear shift lever to the "LOW" position.
- Turn the key "ON". Do not start the engine.
- Purge valve makes click sound for 20 seconds after 5 seconds.
- Check click sound.
- Set the range gear shift lever to the "NEUTRAL" and turn the key "OFF".

If you are not sure with function, consult your local KUBOTA Dealer.

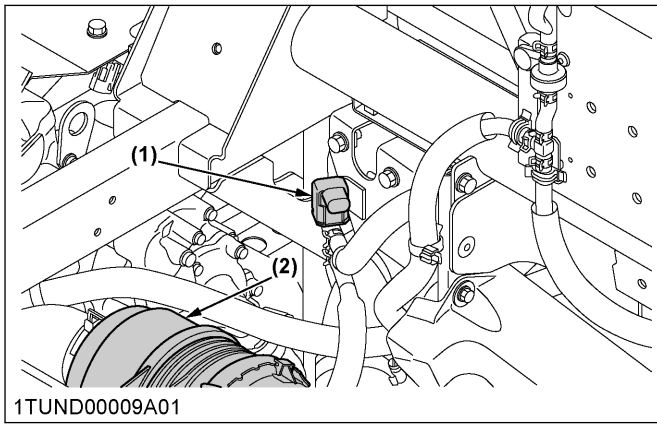

1TUND00009A01
 (1) Purge valve
 (2) Air cleaner

EVERY 1000 HOURS OR EVERY YEAR

Perform the following servicing once every 1000 hours or every year, whichever comes first.

1. Replacing air cleaner primary element and secondary element

(See Cleaning air cleaner primary element on page 72.)

EVERY YEAR

1. Checking fuel line

The fuel line is made of rubber and ages regardless of service period.

Fuel lines should be checked yearly.

⚠ WARNING
To avoid serious injury or death:

- Stop the engine and remove the key when attempting to make the following checks and changes.
- Check the fuel lines periodically. The fuel lines are subject to wear and aging.

1. Park the vehicle on a flat surface, raise the cargo bed, mount the safety support and shut off the engine.
2. If the fuel line and clamps are found to be damaged or deteriorated, replace them.

IMPORTANT :

- When the fuel line is disconnected for maintenance or repair, close both ends of the fuel line with a piece of clean cloth or paper to prevent dust and dirt from entering. In addition, particular care must be taken not to admit dust and dirt into the fuel pump. Entrance of even a small amount of dust or

dirt cause premature wear and malfunction of the fuel pump and injector components.

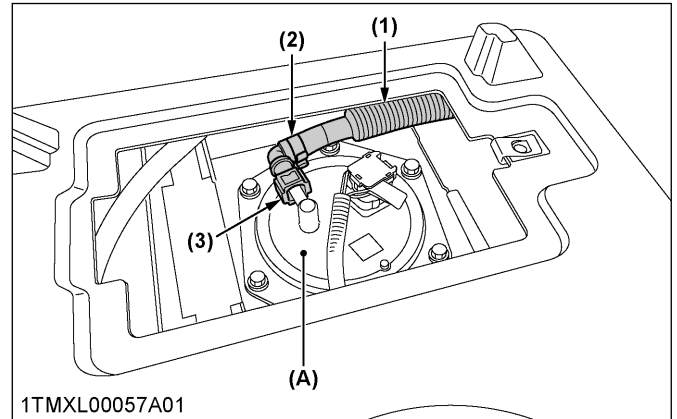

1TMXL00057A01
 (1) Fuel line
 (2) Pipe clamp
 (3) Connector
 (A) Fuel pump

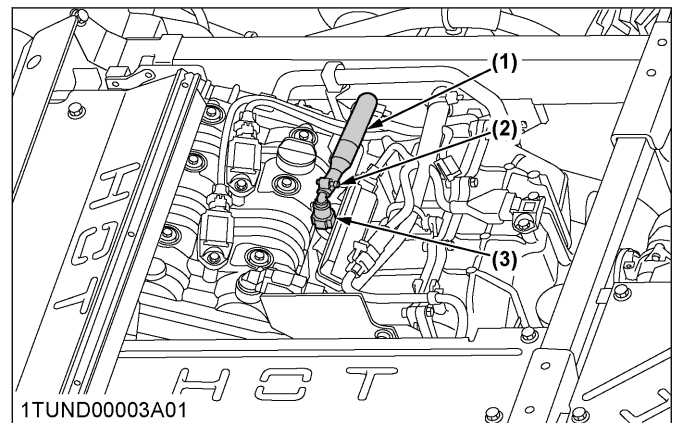

1TUND00003A01
 (1) Fuel line
 (2) Pipe clamp
 (3) Connector

49 states only

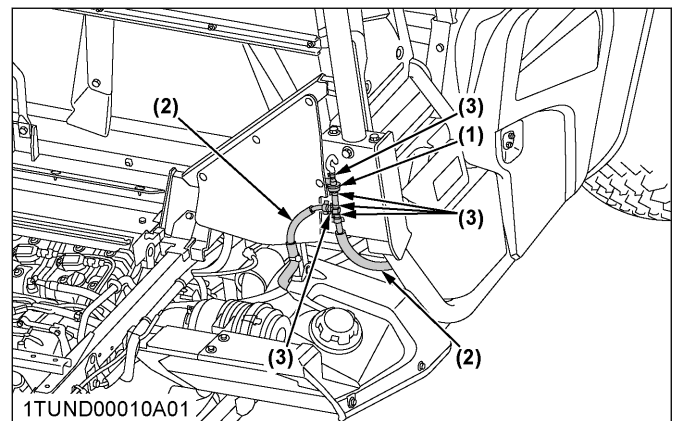

1TUND00010A01
 (1) 2 way valve
 (2) Fuel line
 (3) Pipe clamp

California only

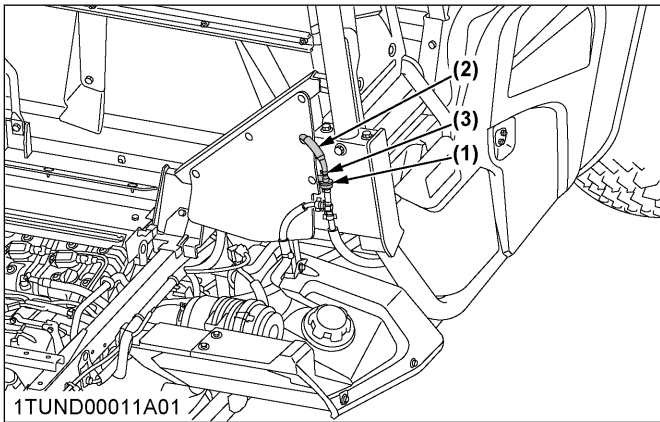

- (1) 2 way valve
- (2) Fuel line
- (3) Pipe clamp

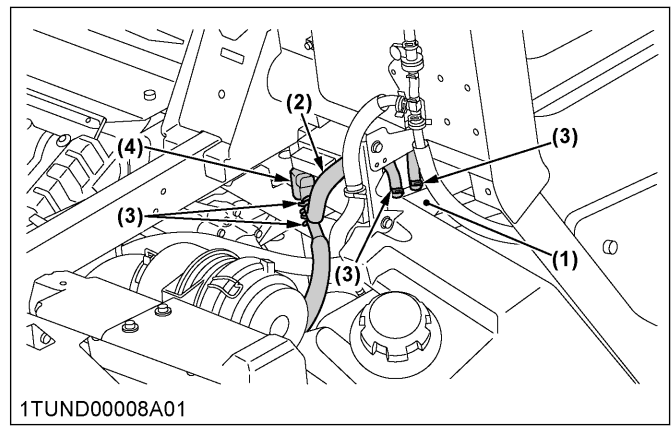

- (1) Carbon canister
- (2) Fuel line
- (3) Pipe clamp
- (4) Purge valve

California only

3. Remove the push rivets and rubber sheet.

NOTE :

- To remove the push rivet:
 1. Push the pin to unlock.
 2. Remove the push rivet.
- To install the push rivet:
 3. Push the pin to ready to install.
 4. Install the push rivet into the hole.
 5. Push the pin to lock.

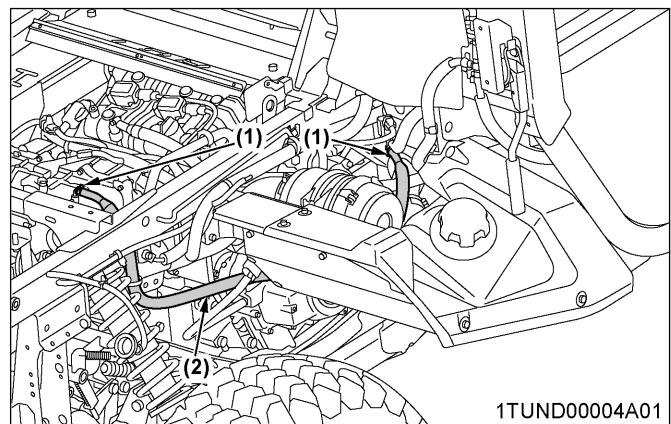

- (1) Pipe clamp
- (2) Fuel line

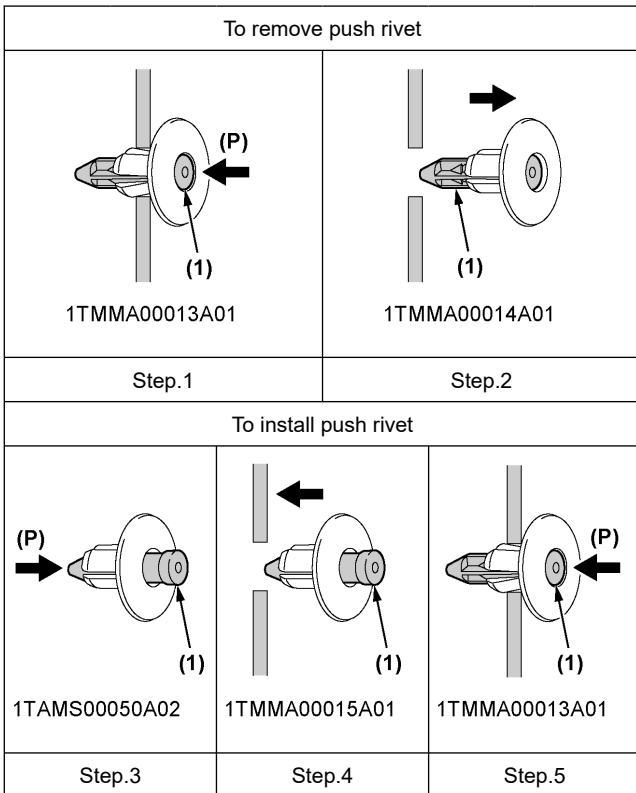

(1) Pin

(P) "PUSH"

2. Checking radiator hose, pipe and clamp

Park the vehicle on a flat surface. Raise the cargo bed and mount the safety support.

Check to see if radiator hoses are properly fixed.

1. If hose clamps are loose or water leaks, tighten bands securely.
2. Replace hoses and tighten hose clamps securely, if radiator hoses are swollen, hardened or cracked.

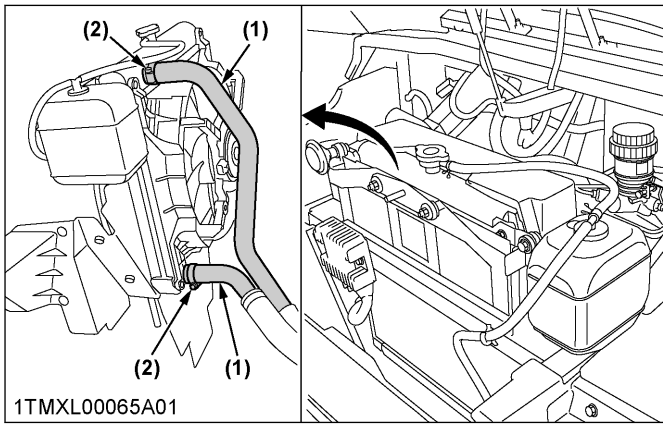

1TMXL00065A01
 (1) Radiator hose
 (2) Clamp band

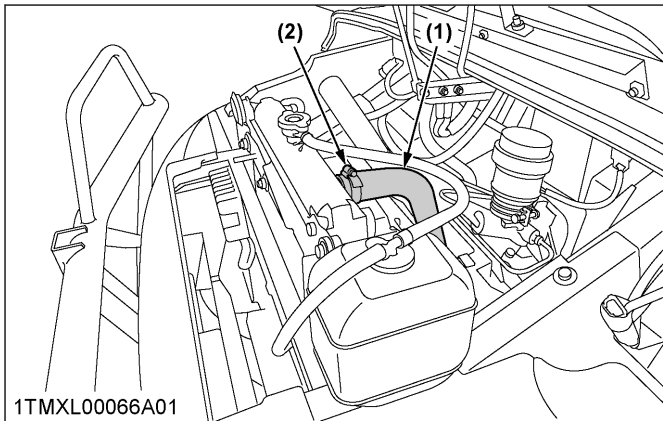

1TMXL00066A01
 (1) Radiator hose
 (2) Clamp band

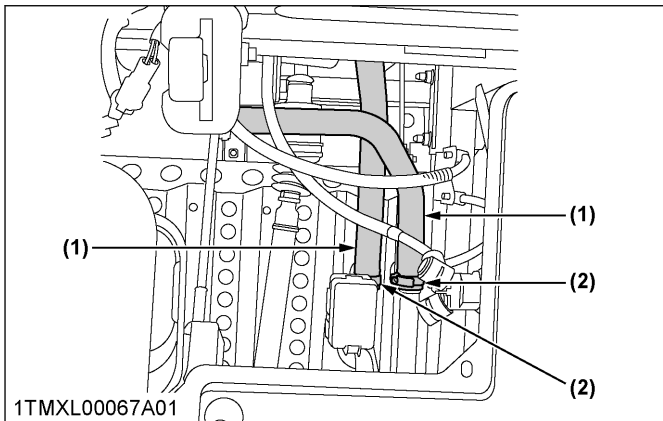

1TMXL00067A01
 (1) Radiator hose
 (2) Clamp band

Precaution at overheating

Take the following actions in the event the coolant temperature is close to or more than the boiling point, which is called "Overheating".

1. Stop the vehicle operation in a safe place, unload the engine and remain at idle.
2. Don't stop the engine suddenly, but stop it after about 5 minutes of unloaded idling.
3. Stay away from the vehicle if steam is released.
4. Check to confirm that there is no danger from the overheat condition.

Details about the cause of the overheat and its countermeasures can be found in a different section.

(See TROUBLESHOOTING on page 94.)

3. Checking intake air line

1. Check to see if the hoses and hose clamps are tight and not damaged around the engine.

Intake pipe and hose

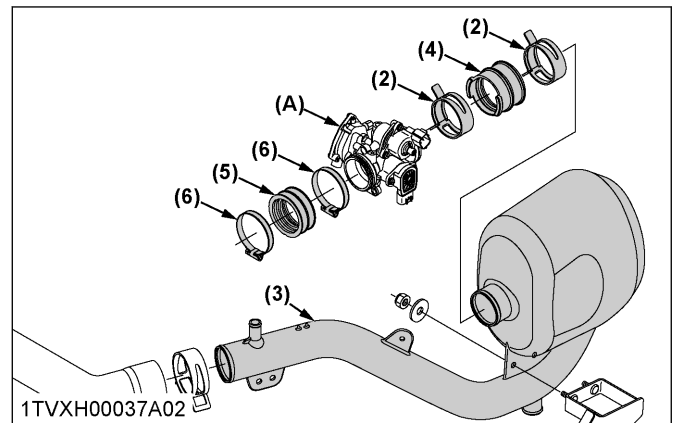
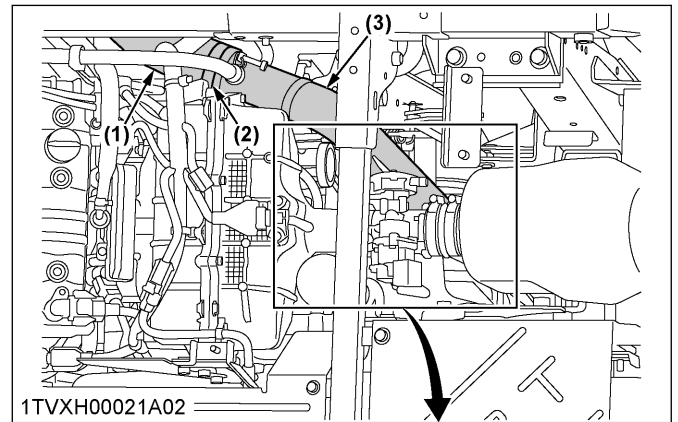

(1) Hose (intake)
 (2) Hose clamp
 (3) Pipe (Intake)
 (4) Adapter
 (5) Adapter
 (6) Band
 (A) Throttle body

2. Check to see if the hoses and hose clamps are tight and not damaged below the floor.

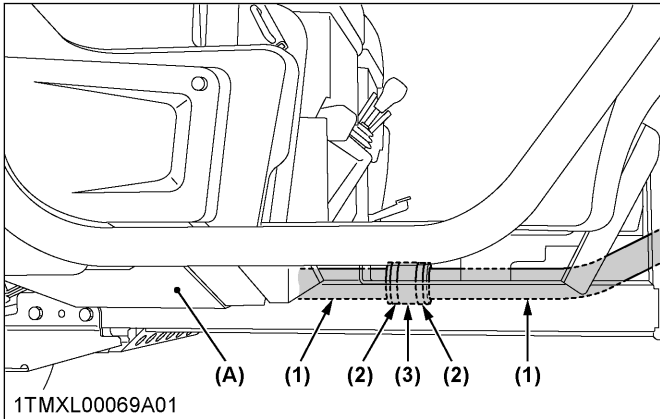

- (1) Hose
- (2) Hose clamp
- (3) Joint
- (A) Hydraulic tank

3. If hoses and clamps are found to be worn or damaged, replace or repair them at once.

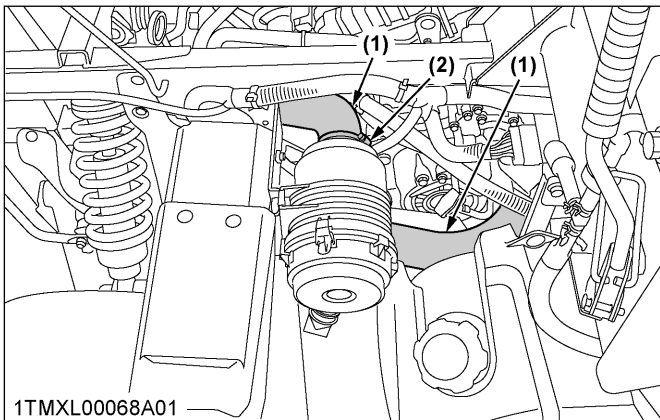

- (1) Hose
- (2) Hose clamp

4. Checking CVT intake air line

1. Check to see if the hoses and hose clamps are tight and not damaged.
2. If any of the hoses and hose clamps is found worn out or damaged, replace or repair it at once.

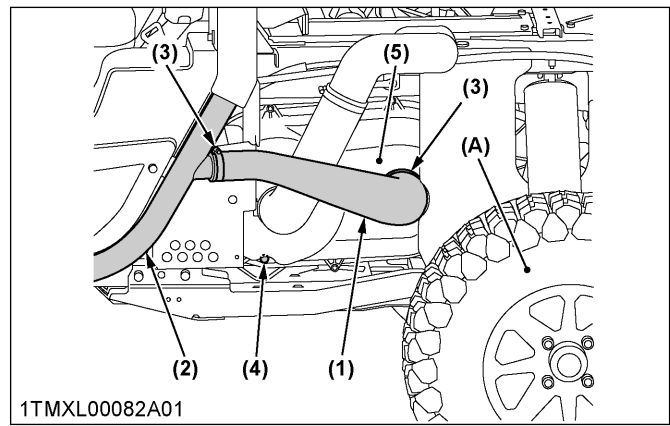

- (1) Hose (Intake → CVT)
- (2) Frame (Intake from inside of hood)
- (3) Hose clamp
- (4) Rubber plug
- (5) CVT cover
- (A) Left rear tire

5. Checking engine breather hose

! WARNING

To avoid serious injury or death:

- Stop the engine and remove the key before checking engine breather hose.

Check to see if engine breather hoses are properly fixed.

1. Stop the engine and let cool down.
2. If hose clamps are loose or oil leaks, tighten bands securely.
3. Replace hoses and tighten hose clamps securely, if engine breather hoses are swollen, hardened or cracked.

Replace hoses and hose clamps every 4 years or earlier if you checked and found that hoses are swollen, hardened or cracked.

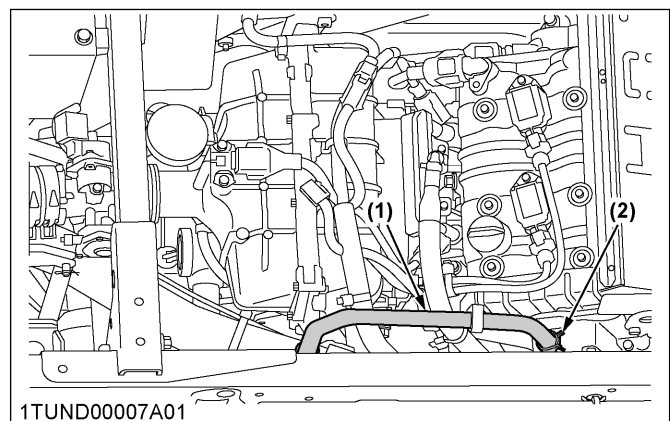

- (1) Engine breather hose
- (2) Clamp

6. Checking brake hose and pipe

1. Check to see that brake hose and pipe are not swollen, hardened or cracked.
2. Check the brake hose and pipe joints for oil leaks.
3. If there is any abnormality, consult your local KUBOTA Dealer for this service.

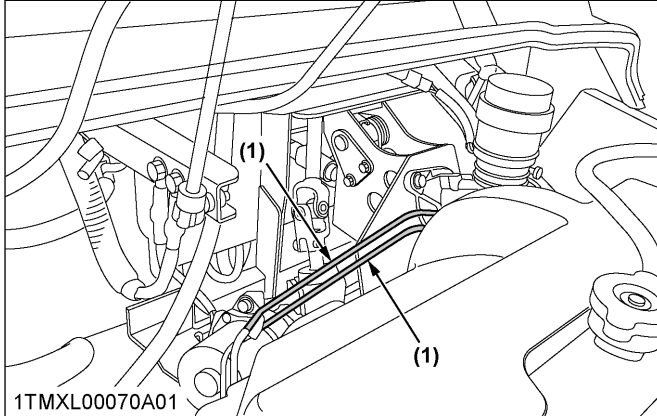

(1) Brake pipe

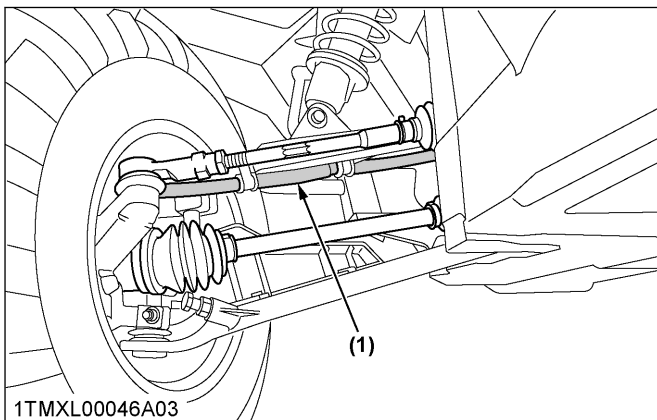

(1) Brake hose

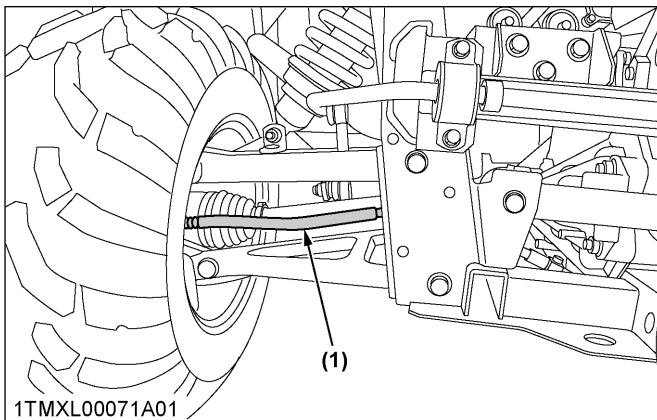

(1) Brake hose

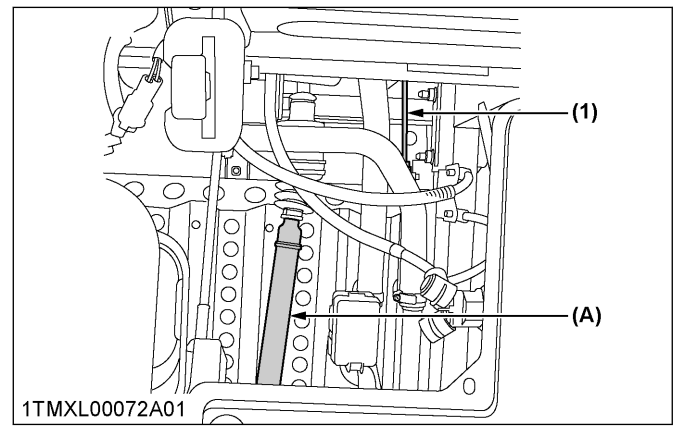

(1) Brake pipe

(A) Drive shaft

EVERY 2 YEARS

1. Changing brake fluid

Consult your local KUBOTA Dealer for this service.
(See Checking brake fluid level on page 66.)

2. Flushing cooling system and changing coolant

WARNING

To avoid serious injury or death:

- Do not remove radiator cap while coolant is hot. When cool, slowly rotate cap to the first stop and allow sufficient time for excess pressure to escape before removing the cap completely.

1. Stop the engine and let cool down.
2. Open the hood.
3. To drain the coolant, open the drain plug and remove radiator cap and engine coolant breather. The radiator cap must be removed to completely drain the coolant.
4. After all coolant is drained, close the drain plug.
5. Fill with clean water and cooling system cleaner.
6. Follow directions of the cleaner instruction.
7. After flushing, fill with clean distilled water and antifreeze until the coolant level is just below the radiator cap. Install the radiator cap securely.
8. Fill with fresh distilled water up to the **[FULL]** mark on the recovery tank.
9. Close the engine coolant breather.
10. Clean the radiator screen and radiator cooling fins.
11. Start and operate the engine for few minutes.
12. Stop the engine and let cool.

13. Check coolant level of recovery tank and add coolant if necessary.

Coolant capacity	6.0 L (6.3 U.S.qts.)
------------------	----------------------

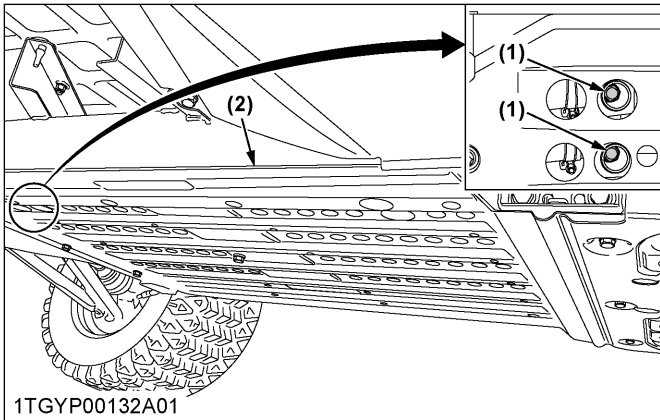

1TGYP00132A01

- (1) Drain plug
- (2) Front skid plate

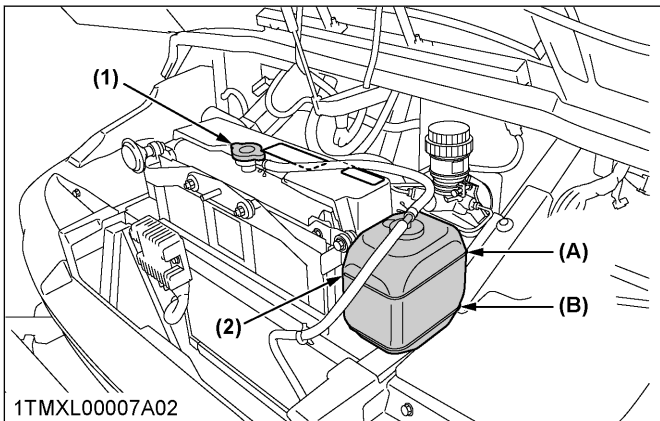

1TMXL00007A02

- (1) Radiator cap
- (2) Recovery tank
- (A) [FULL]
- (B) [LOW]

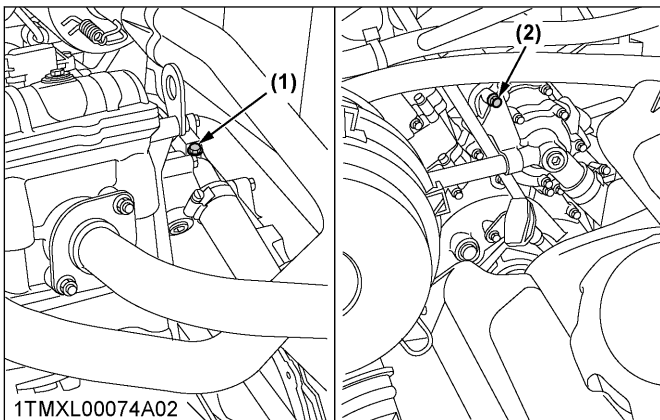

1TMXL00074A02

- (1) Engine coolant breather (left)
- (2) Engine coolant breather (right)

IMPORTANT :

- Do not start engine without coolant.
- Use clean, fresh distilled water and antifreeze to fill the radiator and recovery tank.

- When the antifreeze is mixed with distilled water, the antifreeze mixing ratio is 50 %.
- Securely tighten radiator cap. If the cap is loose or improperly fitted, water may leak out and the engine could overheat.
- Make sure that the engine coolant breather is closed, after filling the coolant.

3. Antifreeze

! WARNING

To avoid serious injury or death:

- When using antifreeze, put on some protection such as rubber gloves. (Antifreeze contains poison.)
- If it is swallowed, seek immediate medical help. Do not make a person throw up unless told to do so by poison control or a health care professional. Use standard first aid and CPR for signs of shock or cardiac arrest. Call your local poison control center or your local emergency number for further assistance.
- When antifreeze comes in contact with the skin or clothing, wash it off immediately.
- Do not mix different types of antifreeze. The mixture can produce chemical reaction causing harmful substances.
- Antifreeze is extremely flammable and explosive under certain conditions. Keep fire and children away from antifreeze.
- When draining fluids from the engine, place some container underneath the engine body.
- Do not pour waste onto the ground, down a drain, or into any water source.
- Also, observe the relevant environmental protection regulations when disposing of antifreeze.

Always use a 50/50 mix of antifreeze and clean soft water in KUBOTA engines. Consult your local KUBOTA Dealer concerning coolant for extreme conditions.

1. Coolant comes in several types. Use ethylene glycol (EG) type for this engine.
2. Before employing the 50/50 mix, fill the radiator with fresh water and empty it again. Repeat this procedure 2 or 3 times to clean up the inside.
3. Mixing the coolant
Premix 50 % antifreeze with 50 % clean soft water. When mixing, stir it up well, and then fill into the radiator.

4. The procedure for the mixing of water and antifreeze differs according to the make of the antifreeze and the ambient temperature. Refer to SAE J1034 standard, more specifically also to SAE J814c.

IMPORTANT :

- **When mixing the antifreeze with water, the antifreeze mixing ratio is 50 %.**

Vol% Antifreeze	Freezing point		Boiling point*	
	°C	°F	°C	°F
50	-37	-34	108	226

* At 1.013×10^5 Pa (760 mmHg) pressure (atmospheric).

A higher boiling point is obtained by using a radiator pressure cap which permits the development of pressure within the cooling system.

5. Adding the coolant
- Add only water if the coolant level reduces in the cooling system by evaporation.
 - If there is a mixture leak, add the antifreeze of the same manufacturer and type in a 50/50 mixing ratio.

IMPORTANT :

- **Never mix different brands of coolant. (Different brands may have different additive components, and the engine may fail to perform as specified.)**

6. When the coolant is mixed, do not use any radiator cleaning agent. The antifreeze contains an anticorrosive agent. If mixed with the cleaning agent, sludge may build up, adversely affecting the engine parts.
7. Kubota's genuine coolant has a service life of 2 years. Change the coolant every 2 years.

NOTE :

- **The above data represent industry standards that necessitate a minimum glycol content in the concentrated antifreeze.**

4. Replacing carbon canister air filter (California only)

Consult your local KUBOTA Dealer for this service.

EVERY 4 YEARS

1. Replacing radiator hose (water pipes)

Consult your local KUBOTA Dealer for this service.

2. Replacing fuel hose

Consult your local Kubota Dealer for this service.

3. Replacing engine breather hose

Consult your local KUBOTA Dealer for this service.

4. Replacing brake master cylinder (inner parts)

Consult your local KUBOTA Dealer for this service.

5. Replacing brake caliper (inner parts)

Consult your local KUBOTA Dealer for this service.

6. Replacing intake air line

Consult your local KUBOTA Dealer for this service. (See Checking intake air line on page 85.)

7. Replacing brake hose and pipe

Consult your local KUBOTA Dealer for this service.

SERVICE AS REQUIRED

1. Replacing fuse

The vehicle electrical system is protected from potential damage by fuses.

A blown fuse indicates that there is an overload or short somewhere in the electrical system.

If any of the fuses should blow, replace with a new one of the same capacity.

IMPORTANT :

- **Before replacing a blown fuse, determine why the fuse blew and make any necessary repairs. Failure to follow this procedure may result in serious damage to the vehicle electrical system. Consult your local KUBOTA Dealer for specific information dealing with electrical problems.**

Replacement procedure

1. Disconnect the negative cable of the battery.
2. Open the seats and remove the utility box and maintenance cover.
3. Remove the fuse box cover.
4. Pull out the blown fuse using fuse puller in the fuse box.
5. Insert a new fuse into the fuse box.
6. Install the fuse box cover and the maintenance cover.
7. Connect the negative battery cable.

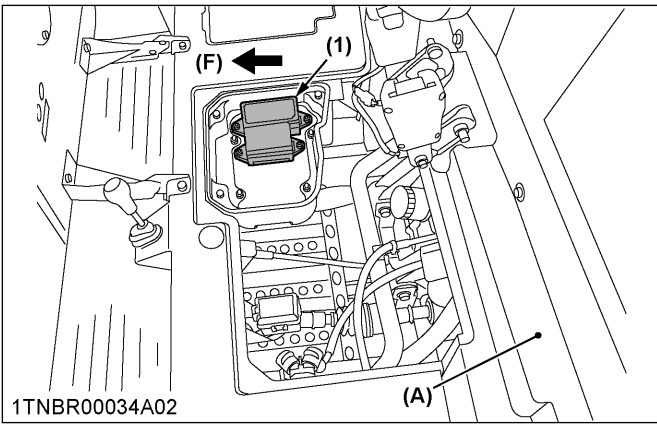

(1) Fuse box

(A) Oil cooler
(F) Front

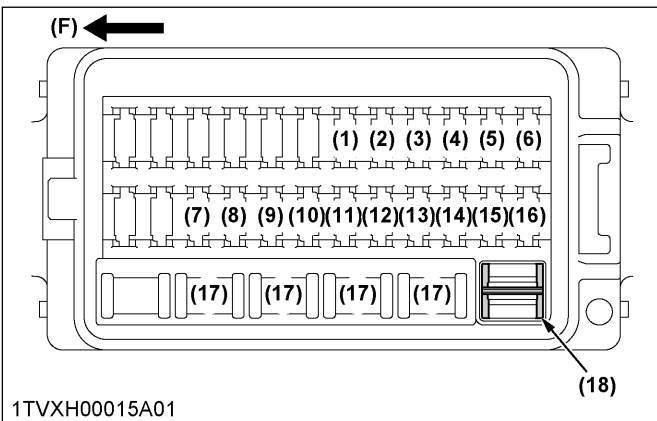

(F) Front

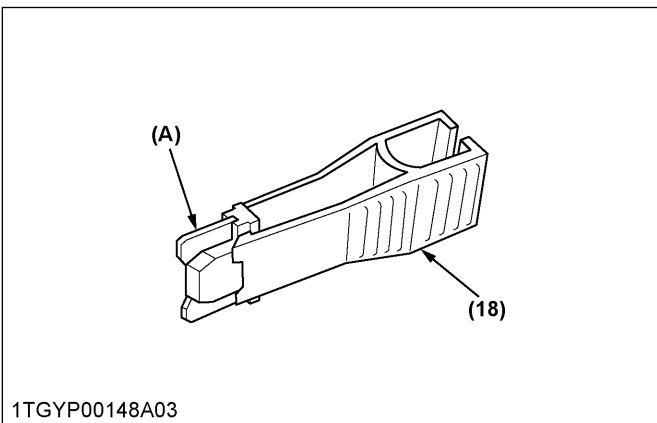

(18) Fuse puller

(A) Fuse

Protected circuit

Fuse no.	Capacity (A)	Protected circuit
1	15	DC output
2	10	CHECK CON/AUX/BACK BUZZER RELAY
3	5	Engine ECU (IGN)
4	5	Meter (IGN)/rotation sensor/shift SW
5	5	EPS (IGN)
6	15	Head light/tail lamp/blinker (F)
7	5	K-OBD
8	5	Engine ECU (BAT)
9	10	IG/INJ/RLY (RAD FAN)/fuel pump
10	30	Radiator fan
11	5	Engine relay
12	15	Blinker (R)/brake lamp/hazard
13	5	Horn
14	15	Beacon
15	15	Work light
16	5	Meter (BAT)
17	30, 15, 10, 5	Spare
18	—	Fuse puller

2. Replacing slow-blow fuses

The slow-blow fuses are intended to protect the electrical cabling. If any of them have blown out, pinpoint the cause. Use only a KUBOTA genuine part.

Replacement procedure

1. Disconnect the negative cable of the battery.
2. Open the seats and remove the utility box and maintenance cover.
3. Remove the slow-blow fuse box cover.
4. Pull out the slow-blow fuse.
5. Insert a new slow-blow fuse into the slow-blow fuse box.
6. Install the slow-blow fuse box cover and the maintenance cover.

7. Connect the negative battery cable.

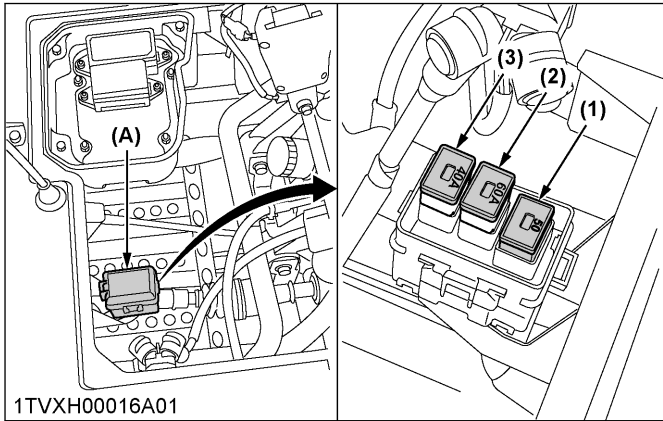

1TVXH00016A01

- (1) Slow-blow fuse
- (2) Slow-blow fuse
- (3) Slow-blow fuse

(A) Fuse box

Slow-blow fuse no.	Capacity (A)	Protected circuit
1	50	Dynamo
2	60	Battery
3	40	EPS (BAT)

3. Replacing light bulb

- Turn signal light (front)
Take the bulb out of the light body and replace it with a new one.
- Other lights
Detach the lens and replace the bulb.

Light	Capacity
Tail light	5 W
Brake light	21 W
Turn signal light (front)	21 W (if equipped)
Turn signal light (rear)	21 W (if equipped)
Work light (rear)	27 W (if equipped)

STORAGE

WARNING

To avoid serious injury or death:

- Do not clean the vehicle with engine running.
- To avoid the danger of exhaust fume poisoning, do not operate the engine in a closed building without proper ventilation.
- When storing, remove the key from the ignition switch.

VEHICLE STORAGE

If you intend to store your vehicle for an extended period of time, follow the procedures outlined as follows.

These procedures will ensure that the vehicle is ready to operate with minimum preparation when it is removed from storage.

1. Check the bolts and nuts for looseness, and tighten if necessary.
2. Apply grease to vehicle areas where bare metal will rust also to pivot areas.
3. Unload the cargo bed.
4. Inflate the tires to a pressure a little higher than usual.
5. Change the engine oil and run the engine to circulate oil throughout the engine block and internal moving parts for about 5 minutes.
6. With all implements lowered to the ground, coat any exposed hydraulic cylinder piston rods with grease (if equipped).
7. Remove the battery from the vehicle. Store the battery following the battery storage procedures. (See Checking battery condition on page 74.)
8. Keep the vehicle in a dry place where the vehicle is sheltered from the elements. Cover the vehicle.
9. Store the vehicle indoors in a dry area that is protected from sunlight and excessive heat. If the vehicle must be stored outdoors, cover it with a waterproof tarpaulin. Put boards under the tires to keep dampness away from tire. Keep the tires out of direct sunlight and extreme heat.

IMPORTANT :

- When washing the vehicle, stop the engine. Allow sufficient time for the engine to cool before washing.
- Do not wash with a high-pressure car-washing machine.

- When washing the vehicle, be careful not to get water in the CVT air outlet. In such case, remove the rubber plug and drain the water.

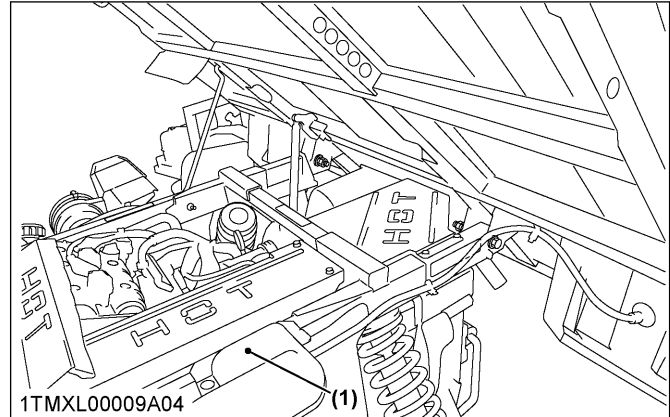

(1) CVT air outlet

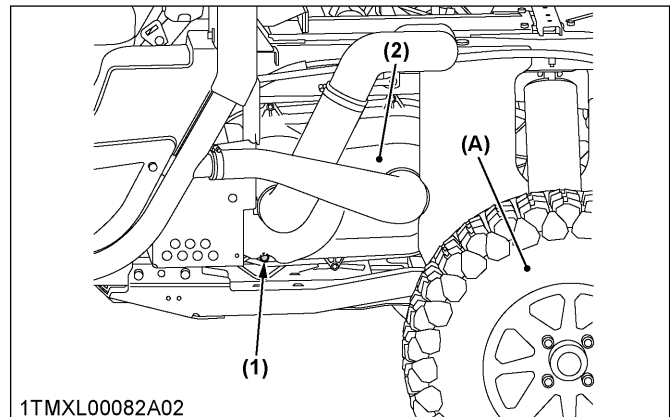

(1) Rubber plug
(2) CVT cover

(A) Left rear tire

- Cover the vehicle after the muffler and the engine have cooled down.

REMOVING THE VEHICLE FROM STORAGE

1. Check the tire air pressure and inflate the tires if they are low.
2. Install the battery. Before installing the battery, be sure it is fully charged.
3. Check all fluid levels (engine oil, transmission oil, brake fluid, engine coolant and any attached implements).

4. Start the engine. Observe all gauges. If all gauges are functioning properly and reading normal, move the vehicle outside. Once outside, park the vehicle and let the engine idle for at least 5 minutes. Shut the engine off and walk around vehicle and make a visual inspection looking for evidence of oil or water leaks.
5. With the engine fully warmed up, release the parking brake and test the brakes for proper adjustment as you move forward. Adjust the brakes as necessary.

TROUBLESHOOTING

If an error code appears on the LCD screen and appears again even after restarting the engine, consult your local KUBOTA Dealer.

ENGINE TROUBLESHOOTING

If something is wrong with the engine, refer to the following table for the cause and its corrective measure.

Trouble	Cause	Countermeasure
Engine does not turn over.	• The range gear shift lever not in the proper position.	• Make sure the range gear shift lever is in "NEUTRAL" position.
	• Key switch is not in the proper position.	• Make sure key switch is in "ON" position.
	• Battery becomes weak and the engine does not turn over quick enough.	• Clean battery cables and terminals.
		• Charge the battery.
	• In cold weather, always remove the battery from the engine, charge and store it indoors. Install it on the machine only when the machine is going to be used.	
	• Fuse is blown.	• Replace the fuse.
Engine will not start.	• No fuel.	• Replenish fuel.
	• Improper or stale fuel. (Fuel quality is poor.)	• Replace fuel and consult your KUBOTA Dealer.
	• Water or dirt in the fuel system.	• Replace fuel and consult your KUBOTA Dealer.
	• Fuel filter clogged or damaged.	• Consult your KUBOTA Dealer.
	• Air cleaner is clogged, or intake blocked.	• Clean or replace the air cleaner element.
	• Spark plug defective.	• Recover the spark plug from wet. (See STARTING WHEN THE ENGINE IS FLOODED on page 30.)
		• Adjust the spark plug gap or replace the spark plug.
		• Check the spark plug wire connection.
• Fuse is blown.	• Replace the fuse.	
• Engine oil viscosity is wrong.	• Use oils of different viscosities, depending on ambient temperature.	
	• In cold weather, use lower viscosity oil.	
Insufficient engine power.	• Insufficient or dirty fuel.	• Check the fuel system.
	• Air cleaner is clogged, or intake blocked.	• Clean or replace the air cleaner element.
	• Spark plug defective.	• Recover the spark plug from wet. (See STARTING WHEN THE ENGINE IS FLOODED on page 30.)
		• Adjust the spark plug gap or replace it.
	• Compression leakage.	• Consult your KUBOTA Dealer.
• Valve clearance is insufficient.	• Consult your KUBOTA Dealer.	
Engine stops suddenly.	• Insufficient fuel.	• Refuel.
	• Engine oil viscosity is wrong.	• Use oils of different viscosities, depending on ambient temperature.

(Continued)

Trouble	Cause	Countermeasure
Engine stops suddenly.	• Engine oil viscosity is wrong.	• In cold weather, use lower viscosity oil.
	• Valve clearance is insufficient.	• Consult your KUBOTA Dealer.
Rough engine running.	• Spark plug defective.	• Recover the spark plug from wet. (See STARTING WHEN THE ENGINE IS FLOODED on page 30.)
		• Adjust the spark plug gap or replace it.
	• Ignition coil defective. (loose connections to spark plug)	• Consult your KUBOTA Dealer.
	• Fuel filter clogged or damaged.	• Consult your KUBOTA Dealer.
	• Improper or stale fuel. (Fuel quality is poor.)	• Replace fuel and consult your KUBOTA Dealer.
	• Air cleaner is clogged.	• Clean or replace the air cleaner element.
Exhaust fumes are colored.	• Overload.	• Reduce load.
	• Low grade fuel is used.	• Use specified fuel.
	• Air cleaner is clogged.	• Clean or replace the air cleaner element.
	• Excessive engine oil.	• Reduce to the specified oil level.
	• Piston ring is worn or stuck.	• Consult your KUBOTA Dealer.
Engine overheats.	• Engine is overloaded.	• Lower speed or reduce load.
	• Engine oil is insufficient.	• Replenish engine oil.
	• Low coolant level.	• Fill cooling system to the correct level; check radiator and hoses for loose connections or leaks.
	• The motor driven fan does not turn.	• Check to see if the fuse is not blown. • Check the electric system.
	• Dirty radiator core or grille screens.	• Remove all trash.
	• Coolant flow route corroded.	• Flush cooling system.
Engine diagnostic light comes on.	—	• Consult your KUBOTA Dealer.
Engine will not idle.	• Spark plug defective.	• Recover the spark plug from wet. (See STARTING WHEN THE ENGINE IS FLOODED on page 30.)
		• Adjust the spark plug gap or replace it.
	• Faulty spark plug.	• Replace the spark plug.
	• Accelerator pedal and cable are not put back in place.	• Check pedal and cable. • Consult your KUBOTA Dealer.

If you have any questions, contact your local KUBOTA Dealer.

ELECTRICAL SYSTEM TROUBLESHOOTING

Trouble	Cause	Countermeasure
All electrical equipment do not operate.	• Battery discharged or defective.	• Recharge or replace.
	• Battery positive cable disconnected or improperly connected.	• Check cable connections. • Repair or replace.
	• Battery negative cable disconnected or improperly connected.	• Check cable connections. • Repair or replace.
	• Slow blow fuse blown.	• Replace.
Fuse blown frequently.	• Short - circuited.	• Repair or replace. (See Replacing fuse on page 89.)
Horn does not sound when horn button is pushed.	• Fuse blown (5 A).	• Replace the fuse.

If you have any questions, consult your local KUBOTA Dealer.

BATTERY TROUBLESHOOTING

Trouble	Cause	Countermeasure	Preventive measure
The starter does not function.	• Battery overused until lights are dim.	• Charge battery sufficiently.	• Charge the battery properly.
	• Battery has not been recharged.		
	• Poor terminal connection.	• Clean the terminal and tighten securely.	• Keep the terminal clean and tight. Apply grease and treat with anti-corrosives.
	• Battery life expired.	• Renew battery.	
From beginning starter does not function, and lights soon become dim.	• Insufficient charging.	• Charge battery sufficiently.	• Battery must be serviced properly before initial use.
When viewed from top, the top of plates look whitish.	• Battery was used with an insufficient amount of electrolyte.	• Add distilled water and charge the battery.	• Regularly check the electrolyte level.
	• Battery was used too much without recharging.	• Charge battery sufficiently.	• Charge the battery properly.
Recharging is impossible.	• Battery life expired.	• Replace battery.	
Terminals are severely corroded and heat up.	• Poor terminal connection.	• Clean the terminal and tighten securely.	• Keep the terminal clean and tight. Apply grease and treat with anti-corrosives.
Battery electrolyte level drops rapidly.	• There is a crack or pin holes in the electrolytic cells.	• Replace battery.	
	• Charging system trouble.	• Consult your local KUBOTA Dealer.	

• If you have any questions, consult your local KUBOTA Dealer.

LIGHTING SYSTEM TROUBLESHOOTING

Trouble	Cause	Countermeasure
Head light does not light.	• Fuse blown (15 A).	• Replace the fuse.
	• Bulb blown.	• Replace the bulb.
Tail light does not light.	• Fuse blown (15 A).	• Replace the fuse.
	• Bulb blown.	• Replace the bulb.
Brake light does not light when stepping on the brake pedal.	• Fuse blown.	• Replace the fuse.
	• Bulb blown.	• Replace the bulb.
	• Brake light is defective.	• Check or replace the brake light.

If you have any questions, consult your local KUBOTA Dealer.

CVT TROUBLESHOOTING

Trouble	Cause	Countermeasure
The machine operation is not smooth.	• CVT belt life expired.	• Consult your KUBOTA Dealer.
	• CVT weight roller is worn.	• Consult your KUBOTA Dealer.
	• Dust or water has accumulated in CVT drive pulley.	• Consult your KUBOTA Dealer.
	• Clutch (inertial clutch) is worn.	• Consult your KUBOTA Dealer.
The machine does not move while engine is running.	• Parking brake is on.	• Release the parking brake.
	• CVT belt is broken.	• Consult your KUBOTA Dealer.

- If you have any questions, consult your local KUBOTA Dealer.

STEERING TROUBLESHOOTING

Trouble	Cause	Countermeasure
Front wheels wander to right or left.	• Tire pressure is uneven.	• Add air to correct pressure.
	• Improper toe-in adjustment (improper alignment).	• Adjust the toe-in.
	• Tie-rod end is loose.	• Tighten the tie-rod.
Heavy steering.	• Assistance of power steering is limited to prevent overheat.	• Have power steering cool down.
	• Tire pressure is unsuitable.	• Correct tire pressure.
	• Battery has not been recharged.	• Charge the battery properly.
	• Fuse is blown.	• Replace the fuse.
	• Power steering system has problem.	• Consult your KUBOTA Dealer.

- If you have any questions, consult your local KUBOTA Dealer.

BRAKE TROUBLESHOOTING

Trouble	Cause	Countermeasure
Brakes not working correctly.	• Brake fluid level is low.	• Check fluid level.
	• Air is in brake system.	• Consult your KUBOTA Dealer.
	• Brake pads are worn.	• Consult your KUBOTA Dealer.

- If you have any questions, consult your local KUBOTA Dealer.

OPTIONS

LIST OF OPTIONS

Consult your local KUBOTA Dealer for further details.

- Additional head lights
- Additional guards
- Backup beeper
- Bed liner
- Cabin
- Cargo bed extender
- Cargo bed sides rail
- Electric bed lift
- Fabric cover
- Front and rear mud guard
- Front blade (74")
- Front trailer hitch and pin
- Front work light
- Head rest
- Heater kit
- Quick clamp
- Rear trailer hitch and pin
- Rear work light
- Roof
- Storage box
- Storage rack
- Strobe light (beacon)
- Tail lamp guards
- Turn signal/hazard light kit
- Winch kit
- Wind shield

EMISSION RELATED WARRANTY

See behind the INDEX.

INDEX

Symbols

4WD lever..... 37

A

air cleaner primary element
 cleaning.....72
 replacing.....83
air cleaner secondary element
 replacing.....83
antifreeze..... 88
around engine
 checking.....62
auxiliary power supply for relay coil 1..... 41
auxiliary power supply for relay coil 2..... 41
auxiliary power supply for relay coil 3..... 41

B

battery
 charging..... 74
 jump starting.....29
 troubleshooting.....96
battery condition
 checking..... 74
brake
 troubleshooting.....98
brake caliper (inner parts)
 replacing.....89
brake fluid
 changing.....87
brake fluid level
 checking.....66
brake hose
 checking.....87
 replacing.....89
brake light
 checking.....79
brake master cylinder (inner parts)
 replacing.....89
brake pad wear
 checking.....71
brake pedal..... 36
 checking.....66,79
brake pipe
 checking.....87
 replacing.....89

C

carbon canister air filter
 checking.....78
 replacing.....89
cargo bed
 hauling loads..... 8

 lowering.....49,61
 raising.....49,61
cargo bed general caution.....47
cargo bed tailgate.....49
check during driving.....38
checking amount of fuel and refueling.....62
clamp
 checking.....84,85
coolant.....58
 changing.....87
coolant level
 checking.....65
coolant temperature gauge.....39
cooling system
 flushing.....87
CVT
 troubleshooting.....97
CVT belt
 checking.....77
CVT intake air line
 checking.....86

D

daily check.....26,62
 checking the tire pressure.....50
differential lock.....42
directions for battery storage.....76
door
 locking.....33
 unlocking.....33
door latch
 checking.....67
drain cap
 checking.....66
driving in 4WD.....43
driving in reverse.....43
driving on hills.....44
driving on unfamiliar terrain.....43
driving through water.....45

E

Easy Checker™
 checking.....67
Easy Checker™ indicators.....38
electric outlet.....41
electric power steering.....37
electrical system
 troubleshooting.....96
engine
 cold weather starting.....28
 jump starting.....29
 starting.....27
 stopping.....29

troubleshooting.....	94
warming up.....	29
engine breather hose	
checking.....	86
replacing.....	89
engine oil	
changing.....	73
engine oil filter	
replacing.....	80
engine oil level	
checking.....	64
engine start system	
checking.....	69
engine valve clearance	
checking.....	81
error code.....	39
exhaust system	
checking.....	77

F

front axle case oil	
changing.....	82
front end.....	61
front trailer hitch (if equipped).....	53
fuel.....	58
fuel gauge.....	39
fuel hose	
replacing.....	89
fuel line	
checking.....	83
fuel pump filter	
checking.....	73
fuse	
replacing.....	89

G

gap	
checking.....	80
glove box (if equipped).....	42
glove box cover (if equipped).....	42
greasing.....	69

H

hazard light switch (if equipped).....	35
head light	
checking.....	67
head light switch.....	34
high speeds	
driving.....	8
hood.....	60
horn button.....	35
hourmeter.....	39

I

inclement conditions.....	7
---------------------------	---

instrument panel.....	25
intake air line	
checking.....	85
replacing.....	89

J

joint boot	
checking.....	67

L

light bulb	
replacing.....	91
lighting system	
troubleshooting.....	97
location of parts.....	22
lubricants.....	58
lubricating oil	
changing.....	33

M

machine	
operating on slopes.....	7
specification table.....	19
maintenance intervals.....	55
max. cargo bed load.....	47
muffler spark arrester	
cleaning.....	77

N

new vehicle.....	33
------------------	----

O

odometer.....	39
options	
list.....	99
other miscellaneous.....	8

P

parking brake	
adjusting.....	79
applying.....	27
checking.....	67
releasing.....	27
parking brake lever.....	37,40
pipe	
checking.....	84
purge valve	
checking.....	82

R

radiator hose	
checking.....	84
radiator hose (water pipes)	
replacing.....	89

radiator screen	
cleaning.....	65
range gear shift lever.....	36
rear end.....	61
rear trailer hitch (if equipped).....	53
ROPS	
checking.....	67

S

safety	
before operating the vehicle.....	5
general information.....	5
operating on slopes.....	7
operating the vehicle.....	6
starting to operate the vehicle.....	6
safety concerns in Canada	
reporting.....	18
safety for children.....	7
safety labels.....	10
care.....	15
seat.....	60
seat belt.....	34
checking.....	67
service intervals.....	55
servicing of vehicle.....	17
shock absorber spring	
adjustment.....	51
skidding.....	45
sliding.....	45
slow-blow fuses	
replacing.....	90
spark plug condition	
checking.....	80
speed control pedal.....	37
speedometer.....	40
starting when the engine is flooded.....	30
steering	
troubleshooting.....	97
steering wheel (if equipped)	
tilting.....	34
suspension arm bushings	
checking.....	79

T

tachometer.....	40
tire	
checking.....	69
tire inflation pressure	
checking.....	68
tire type	
use.....	50
toe-in	
adjusting.....	76
towing.....	8
transmission fluid	
changing.....	81

transmission fluid level	
checking.....	64
transmission gear shift switch	
checking.....	77
transport the vehicle safely.....	54
traveling speeds.....	20
traversing hillsides.....	45
turn signal light	
switch (if equipped).....	35

U

utility box.....	42
------------------	----

V

vehicle	
before operating.....	5
operating.....	6
parking.....	8
removing from storage.....	92
scrapping.....	17
servicing.....	8
starting.....	33
starting to operate.....	6
stopping.....	38
transporting.....	8
turning.....	44
warranty.....	17
vehicle (new)	
operating caution.....	33
vehicle limitations.....	21
vehicle storage.....	92
vehicles (new)	
changing lubricating oil.....	33

W

walk around inspection.....	62
warranty.....	17
wheel fastener torque	
checking.....	71
wheels.....	51
winch mount bracket.....	53

EMISSION RELATED WARRANTY

Code No. K7821-7132-1

FEDERAL AND CALIFORNIA EMISSION CONTROL SYSTEMS WARRANTY STATEMENT

LIMITED WARRANTY FOR OFF-ROAD VEHICLES

YOUR WARRANTY RIGHTS AND OBLIGATIONS

The U.S. Environmental Protection Agency (EPA), the California Air Resources Board (CARB), and KUBOTA Corporation are pleased to explain the Federal and California Emission Control System Warranty on your 2023 model year off-highway recreational vehicles. Off-highway recreational vehicles produced in 2023 model year must be designed, built and equipped to conform at the time of sale to the ultimate purchaser with all applicable laws, rules and regulations of the U.S. Environmental Protection Agency (EPA) in 40 CFR sections 1051 et seq. and California Air Resources Board (CARB) in 13 CCR sections 2400 et seq.. KUBOTA must warrant the emission control system on off-highway recreational vehicles for the periods of time listed below provided there has been no abuse, neglect, improper maintenance, or unapproved modification to your vehicle. This emission warranty is applicable in all states of the U.S.A and all provinces and territories of CANADA.

Your exhaust and evaporative emission control system may include parts such as an ECM, the fuel injection system, the ignition system, catalytic converter, fuel tanks, fuel lines or hoses, fuel caps, valves, canisters, filters, hoses, clamps, connectors and other associated components. Also included may be belts and other emission-related assemblies.

Where an emission warrantable condition exists, KUBOTA will repair your off-highway recreational vehicle or emission-related component at no cost to you, including diagnosis, parts and labor.

MANUFACTURER'S WARRANTY COVERAGE

You will not be charged for diagnosis, repair, replacement, or adjustment of parts containing an emission-related defect during the applicable warranty period. The applicable warranty periods are as follows:

1. The exhaust emissions defect warranty period for both Federal and California 2023 model year vehicles is 5,000 km (~3,000 miles), or 500 hours of engine operation, or 30 months, whichever comes first (see "*PARTS LIST*" below);
2. The evaporative emissions defect warranty period for Federal 2023 model year vehicles is two (2) years;
3. The evaporative emissions defect warranty periods for California 2023 model year vehicles are:
 - a. emission-related parts: 2,500 miles (~4,000 km), or 250 hours of engine operation, or 30 months or whichever comes first;
 - b. "*high-priced*" emission-related parts: 5,000 miles (~8,000 km), or 500 hours of engine operation, or 60 months, whichever comes first.

Please refer to the following "*PARTS LIST*" for a complete list of emission-related parts covered by these warranties.

OWNER'S WARRANTY RESPONSIBILITIES

1. As the off-highway recreational vehicle owner you are responsible for the performance of the required maintenance listed in your KUBOTA operator's manual. KUBOTA recommends that you retain all receipts covering maintenance on your vehicle, but KUBOTA cannot deny warranty solely for the lack of receipts or for your failure to ensure the performance of a scheduled maintenance.
2. As the vehicle owner, you should also be aware that KUBOTA may deny your warranty coverage if your off-highway recreational vehicle or a part has failed due to abuse, neglect, improper maintenance or unapproved modifications.
3. Your off-highway recreational vehicle is designed to operate on fuel as specified in the operator's manual. Use of any other fuel may result in your engine no longer operating in compliance with Federal or California's emissions requirements.
4. You are responsible for presenting your vehicle to a KUBOTA Dealer or service station as soon as a problem exists. The warranty repairs should be completed in a reasonable amount of time, not to exceed 30 days.
5. If you have any questions regarding your warranty rights and responsibilities, you should contact one of the following:
 - KUBOTA TRACTOR CORPORATION, National Service Department by phone at 1-888-458-2682, or at KubotaEmissionsWarranty@kubota.com
 - KUBOTA CANADA LTD Customer Service Inquiries: 1-800-405-6916, or at kcl_g.customerservice@kubota.com
 - U.S. Environmental Protection Agency (EPA), 2000 Traverwood Drive, Ann Arbor, MI 48105.
 - California Air Resources Board (CARB), 9528 Telstar Avenue, EL Monte, CA 91731

DEFECT WARRANTY COVERAGE

The emissions warranty period for the vehicle begins on the date the vehicle is delivered to the ultimate purchaser. KUBOTA warrants to the ultimate purchaser and each subsequent purchaser that your vehicle shall be:

- a. Designed, built and equipped to conform, at the time of sale, with all applicable laws, rules and regulations; and.
- b. Free from defects in materials and workmanship that may cause the failure of a warranted part. All replacement parts must be identical in all material respects to that part as described in the off-highway recreational vehicle manufacturer's Executive Order of Certification application.

The warranty on emission-related parts will be interpreted as follows:

1. Any warranted part that is not scheduled for replacement as part of maintenance in the written instructions furnished with the new vehicle must be warranted for the warranty period as defined above the section entitled Manufacturer's Warranty Coverage. If any such part fails during the period of warranty coverage, it must be repaired or replaced by KUBOTA according to subsection 4 below. Any such part repaired or replaced under the warranty must be warranted for the remaining warranty period.
2. Any warranted part that is scheduled only for regular inspection in the written instructions furnished with the new vehicle must be warranted for the warranty period defined as above in the section entitled Manufacturer's Warranty Coverage. A statement in such written instructions to the effect of "*repair or replace as necessary*" will not reduce the period of warranty coverage. Any such part repaired or replaced under warranty must be warranted for the remaining warranty period.
3. Any warranted part that is scheduled for replacement as required maintenance in the written instructions furnished with the new vehicle must be warranted for the period of time prior to the first scheduled replacement point for that part. If the part fails prior to the first scheduled replacement, the part must be repaired or replaced by the manufacturer according to subsection 4 below. Any such part repaired or replaced under warranty must be warranted for the remainder of the period prior to the first scheduled replacement point for the part.
4. Repair or replacement of any warranted part under the warranty provisions of this article must be performed at no charge to the off-highway recreational vehicle owner at a warranty station, except in the case of a temporary repair when a warranted part or a warranty station is not reasonably available to the vehicle owner. In the event a temporary repair is permitted according to section 8 below, repairs may be performed at any available service

establishment, or by the owner, using any replacement part. The manufacturer must reimburse the owner for his or her expenses including diagnostic charges for such temporary repair or replacement, not to exceed KUBOTA's suggested retail price for all warranted parts replaced and labor charges based on KUBOTA's recommended time allowance for the warranty repair and the geographically appropriate hourly rate.

5. Notwithstanding the provisions of subsection 4 above, warranty services or repairs must be provided at all KUBOTA dealerships that are owned by KUBOTA or are franchised to service the subject vehicle.
6. The off-highway recreational vehicle owner must not be charged for diagnostic labor that leads to the determination that a warranted part is in fact defective, provided such diagnostic work is performed at a warranty station.
7. KUBOTA is liable for damages to other components proximately caused by a failure under warranty of any warranted part.
8. Throughout the warranty period defined as above in the section entitled Manufacturer's Warranty Coverage, KUBOTA must maintain a supply of warranted parts sufficient to meet the expected demand for such parts. The lack of availability of such parts or the incompleteness of repairs within a reasonable time period, not to exceed 30 days from the time the vehicle is initially presented to the warranty station for repair, will qualify the need for a temporary repair for purposes of section 4 above.
9. Any replacement part designated by KUBOTA may be used in the warranty repairs provided without charge to the off-highway recreational vehicle owner. Such use will not reduce the warranty obligations of KUBOTA, except that KUBOTA will not be liable under the statutory Article for repair or replacement of any replacement part which is not a warranted part (except as provided under section 7 above).
10. Any add-on or modified part exempted by the Air Resources Board from the provisions of section 27156 of the California Vehicle Code may be used on an off-highway recreational vehicle. Such use, in and of itself, will not be grounds for disallowing a warranty claim made under the provisions of this Article. KUBOTA is not liable under the provisions of this Article to warrant failures of warranted parts caused by the use of an add-on or modified part(s) unless such part(s) are also warranted.

PARTS LIST

1. Listed below are the exhaust emission-related parts covered by Federal and California Emission Control Systems Warranties: 5,000 km (~3,000 miles), or 500 hours of engine operation, or 30 months, whichever comes first:
 - a. Fuel metering system
 - Fuel injection system
 - Air/fuel ratio of feedback and control system
 - b. Air induction system
 - Intake manifold or air intake system
 - Air mass sensor assembly
 - Air cleaner element
 - c. Catalyst thermal reactor system
 - Three-way catalytic converter
 - Thermal reactor
 - Exhaust manifold
 - d. Positive crankcase ventilation (PCV) system
 - PCV valve
 - Oil filler cap
 - e. Ignition control system
 - Engine control module (ECM)
 - Ignition module(s)
 - f. Miscellaneous items used in above systems
 - Vacuum, temperature, and time sensitive valves and switches.
 - Sensors used for electronic controls.
 - Hoses, belts, connectors, assemblies, clamps, fittings, tubing, sealing gaskets or devices, and mounting hardware.
 - Pulleys, belts and idlers.

EMISSION RELATED WARRANTY

2. Listed below are the evaporative emission-related parts covered by Federal and California Emission Control Systems Warranties. If any evaporative emission-related part on your off-highway recreational vehicles is defective, the part will be repaired or replaced by Kubota Corporation:
 - a. Evaporative emission-related parts: For Federal models outside of California-two (2) years; for California models in California -30 months, 2,500 miles (~4,000 km), or 250 hours of operation, whichever comes first.
 - Fuel tank (Federal warranty applies)
 - Fuel cap
 - Fuel line
 - Fuel line fittings
 - Fuel couplers
 - Clamps
 - Vapor hoses
 - Control (2-way) valve
 - Purge valve (**RTV-XG850 EVAP** Model offered in California)
 - Canister bracket (**RTV-XG850 EVAP** Model offered in California)
 - b. *“high-priced”* evaporative emission-related parts: California models in California - 60 months, 5000 miles (~8,000 km), or 500 hours of engine operation, whichever comes first.
 - Fuel tank
 - Carbon canister
 - Engine control module (ECM)

GARANTIE LIÉE AUX ÉMISSIONS

Code N° K7821-7132-1

DÉCLARATION DE GARANTIE DES SYSTÈMES DE CONTRÔLE DES ÉMISSIONS FÉDÉRAUX ET CALIFORNIENS

GARANTIE LIMITÉE POUR LES VÉHICULES HORS ROUTE

VOS DROITS ET OBLIGATIONS DE GARANTIE

L'Environmental Protection Agency des États-Unis (EPA), le California Air Resources Board (CARB) et KUBOTA Corporation sont heureux d'expliquer la garantie des systèmes de contrôle des émissions selon les normes fédérales et californiennes pour vos véhicules de loisirs hors route modèle 2023. Les véhicules de loisirs hors route produits en 2023 doivent être conçus, construits et équipés de manière à être conformes au moment de leur vente, à toutes les lois, règles et réglementations applicables dans les sections 1051 et suiv. du CFR 40 de l'Agence de Protection de l'Environnement (EPA) des États-Unis et dans les sections 2400 et suiv. du CCR 13 du California Air Resources Board (Bureau californien des ressources en air) (CARB). KUBOTA doit garantir le système de contrôle des émissions pour les véhicules de loisirs hors route pour les périodes indiquées ci-dessous, à la condition qu'il n'y ait pas eu d'abus, de négligence, d'entretien incorrect ou de modification non approuvée sur votre véhicule. Cette garantie du contrôle des émissions est applicable dans tous les états des États-Unis et dans toutes les provinces et territoires du CANADA.

Votre système de contrôle des émissions d'échappement et par évaporation peut inclure des pièces telles qu'un ECM, le système d'injection de carburant, le système d'allumage, le convertisseur catalytique, les réservoirs de carburant, les tuyaux ou les flexibles d'alimentation en carburant, les bouchons de carburant, les soupapes, les réservoirs, les filtres, les flexibles, les colliers, les raccords et tout autre composant associé. Les courroies et autres ensembles liés aux émissions peuvent également être inclus.

Si une condition de garantie existe concernant les émissions, KUBOTA réparera votre véhicule de loisirs hors-route ou composant lié aux émissions sans frais, y compris le diagnostic, les pièces et la main d'œuvre.

COUVERTURE DE LA GARANTIE DU FABRICANT

Vous ne serez pas facturé pour le diagnostic, la réparation, le remplacement ou le réglage des pièces contenant un défaut lié aux émissions durant la période de garantie applicable. Les périodes de garantie applicables sont les suivantes :

1. La période de garantie contre les vices d'émissions polluantes pour les modèles de véhicules de l'année 2023, fédéraux et californiens, est de 5,000 km (~ 3,000 milles), ou 500 heures de fonctionnement du moteur, ou 30 mois, selon la première échéance (voir « LISTE DES PIÈCES » ci-dessous) ;
2. La période de garantie contre les vices d'émission par évaporation pour les véhicules du modèle fédéral de l'année 2023 est de deux (2) ans ;

3. Les périodes de garantie contre les vices d'émission par évaporation pour les véhicules du modèle californien de l'année 2023 sont :
 - a. pièces relatives aux émissions : environ 4000 km (2500 milles), ou 250 heures de fonctionnement du moteur, ou 30 mois, ou selon la première éventualité;
 - b. pièces liées aux émissions à « *prix élevé* » : environ 8000 km (5000 milles), 500 heures de fonctionnement du moteur ou 60 mois, selon la première éventualité.

Veillez vous reporter à la « *LISTE DES PIÈCES* » pour obtenir une liste complète des pièces liées aux émissions couvertes par ces garanties.

RESPONSABILITÉS DE LA GARANTIE DU PROPRIÉTAIRE

1. En tant que propriétaire du véhicule de loisirs hors-route, vous êtes responsable de la réalisation de l'entretien requis présenté dans votre manuel de l'utilisateur KUBOTA. KUBOTA vous recommande de conserver tous les reçus couvrant l'entretien de votre véhicule, mais KUBOTA ne peut refuser la garantie uniquement pour le manque de reçus ou pour votre incapacité à assurer l'exécution d'un entretien planifié.
2. En tant que propriétaire du véhicule, vous devez également être informé que KUBOTA peut refuser la couverture de votre garantie si votre véhicule de loisirs hors-route ou une pièce est défectueux en raison d'abus, de négligence, d'un entretien inapproprié ou de modifications non approuvées.
3. Votre véhicule de loisirs hors-route est conçu pour fonctionner avec le carburant spécifié dans le manuel de l'utilisateur. L'utilisation de tout autre carburant peut faire en sorte que votre moteur ne fonctionne plus conformément aux exigences des modèles Federal ou California en matière d'émissions.
4. Il est de votre responsabilité de présenter votre véhicule à un concessionnaire KUBOTA ou dans une station-service dès qu'un problème survient. Les réparations sous garantie doivent être effectuées dans un délai raisonnable, ne dépassant pas 30 jours.
5. Si vous avez des questions concernant vos droits et responsabilités en matière de garantie, utilisez l'un des contacts suivants :
 - KUBOTA TRACTOR CORPORATION, Département d'entretien national, par téléphone au 1-888-458-2682 ou à l'adresse KubotaEmissionsWarranty@kubota.com
 - Questions au service à la clientèle de KUBOTA CANADA LTD : 1-800-405-6916, ou à l'adresse kcl_g.customerservice@kubota.com
 - Agence de protection de l'environnement des États-Unis (EPA), 2000 Traverwood Drive, Ann Arbor, MI 48105.
 - California Air Resources Board (Bureau californien des ressources en air) (CARB), 9528 Telstar Avenue, EL Monte, Californie 91731

COUVERTURE DE LA GARANTIE EN MATIÈRE DE DÉFAUTS

La période de garantie des émissions pour le véhicule commence à la date à laquelle le véhicule est livré à l'acheteur final. KUBOTA garantit à l'acheteur final et à chaque acheteur ultérieur que votre véhicule sera :

- a. Conçu, construit et équipé pour se conformer, au moment de la vente, à toutes les lois, règles et réglementations applicables; et.
- b. Exempt de défauts de matériaux et de fabrication pouvant entraîner la défaillance d'une pièce sous garantie. Toutes les pièces de rechange doivent être identiques à tous les égards à cette pièce, comme indiqué dans la demande d'Ordre de Certification du fabricant du véhicule de loisirs hors-route.

La garantie sur les pièces relatives aux émissions sera interprétée comme suit :

1. Toute pièce sous garantie qui n'entre pas dans le programme de remplacement du cadre d'entretien dans la notice écrite fournie avec le nouveau véhicule doit être garantie pour la période de garantie telle que définie au-dessus de la section intitulée Couverture de la Garantie du Fabricant. Si une telle pièce tombe en panne pendant la période de la couverture de la garantie, elle doit être réparée ou remplacée par KUBOTA conformément au paragraphe 4 ci-dessous. Toute pièce ainsi réparée ou remplacée sous garantie doit être garantie pour la période de garantie restante.

2. Toute pièce sous garantie qui entre uniquement dans le programme d'inspection normal dans la notice écrite fournie avec le nouveau véhicule doit être garantie pour la période de garantie telle que définie au-dessus de la section intitulée Couverture de la Garantie du Fabricant. Une déclaration dans ces instructions écrites à l'effet de « *réparer ou remplacer si nécessaire* » ne réduira pas la période de couverture de la garantie. Toute pièce ainsi réparée ou remplacée sous garantie doit être garantie pour la période de garantie restante.
3. Toute pièce garantie dont le remplacement est prévu dans le cadre des instructions écrites fournies avec le nouveau véhicule, doit être garantie pour la période de temps antérieure au premier remplacement programmé pour cette pièce. Si la pièce tombe en panne avant le premier remplacement programmé, elle doit être réparée ou remplacée par le fabricant conformément au paragraphe 4 ci-dessous. Toute pièce réparée ou remplacée sous garantie doit être garantie pour le reste de la période précédant le premier remplacement programmé pour la pièce.
4. La réparation ou le remplacement de toute pièce couverte par la garantie de cet article doit être effectué sans frais pour le propriétaire du véhicule de loisirs hors-route dans un centre de garantie, sauf dans le cas d'une réparation provisoire si une pièce sous garantie ou un centre de garantie n'est pas raisonnablement disponible pour le propriétaire du véhicule. Si une réparation provisoire est autorisée conformément à la section 8 ci-dessous, les réparations peuvent être effectuées dans n'importe quel établissement de service disponible ou par le propriétaire en utilisant n'importe quelle pièce de rechange. Le fabricant doit rembourser le/la propriétaire pour ses frais, y compris les frais de diagnostic pour une réparation ou un remplacement provisoire, sans dépasser le prix de vente au détail suggéré par KUBOTA pour toutes les pièces sous garanties remplacées et les frais de main d'œuvre basés sur un temps recommandé par KUBOTA pour la réparation sous garantie et selon le tarif horaire approprié à la région.
5. Nonobstant les dispositions de la sous-section 4 ci-dessus, les entretiens ou les réparations sous garantie doivent être réalisés dans toutes les agences KUBOTA appartenant à KUBOTA ou franchisées pour l'entretien du véhicule sujet.
6. Le propriétaire du véhicule de loisirs hors-route ne doit pas être facturé pour le travail de diagnostic visant à déterminer qu'une pièce garantie est défectueuse, à la condition que ce travail de diagnostic soit effectué dans une station agréée.
7. KUBOTA est responsable des dommages aux autres composants causés par une défaillance, sous garantie, de toute pièce garantie.
8. Pendant la période de garantie définie ci-dessus dans la section intitulée Couverture de la Garantie du Fabricant, KUBOTA doit assurer une fourniture de pièces garanties en quantité suffisante pour répondre à la demande concernant ces pièces. Le manque de disponibilité de ces pièces ou le retard dans les réparations hors d'un délai raisonnable, qui ne doit pas dépasser 30 jours à compter de la date à laquelle le véhicule est initialement présenté au centre de garantie pour la réparation, justifiera la nécessité d'une réparation provisoire pour les besoins de la section 4 ci-dessus.
9. Toute pièce de rechange désignée par KUBOTA peut être utilisée dans les réparations sous garanties effectuées sans frais pour le propriétaire du véhicule de loisirs hors-route. Une telle utilisation ne réduira pas les obligations de garantie de KUBOTA, sauf que KUBOTA ne pourra être tenu responsable, d'après l'Article juridique, de la réparation ou du remplacement d'une pièce qui n'est pas sous garantie (sauf sous réserve de la section 7 ci-dessus).
10. Toute pièce ajoutée ou modifiée, exclue par l'Air Resources Board, des dispositions de la section 27156 du California Vehicle Code peut être utilisée sur un véhicule de loisir hors route. Une telle utilisation, en elle-même, ne constitue pas un motif pour refuser une réclamation de garantie effectuée en vertu des dispositions de cet Article. KUBOTA n'est pas responsable, sous les dispositions de cet Article, de la garantie des pannes des pièces garanties causées par l'utilisation d'une ou de pièces ajoutées ou modifiées, à moins que ces pièces ne soient également garanties.

LISTE DES PIÈCES

1. Vous trouverez ci-dessous la liste des pièces liées aux émissions d'échappement couvertes par les garanties des systèmes de contrôle des émissions fédéraux et californiens : 5000 km (~ 3000 milles), 500 heures de fonctionnement du moteur ou 30 mois, selon la première éventualité :
 - a. Système de comptage du carburant
 - Système d'injection de carburant

GARANTIE LIÉE AUX ÉMISSIONS

- Rapport air/carburant du système commande et de retour
 - b. Système d'induction d'air
 - Collecteur d'admission ou système d'admission d'air
 - Ensemble de capteur de masse d'air
 - Élément du filtre à air
 - c. Système de réacteur thermique à catalyseur
 - Convertisseur catalytique à trois voies
 - Réacteur thermique
 - Collecteur d'échappement
 - d. Système de ventilation positive de carter-moteur (VPCM)
 - Soupape VPCM
 - Bouchon de remplissage d'huile
 - e. Système de commande d'allumage
 - Module de commande du moteur (ECM)
 - Module(s) d'allumage
 - f. Éléments divers utilisés dans les systèmes ci-dessus
 - Soupapes et interrupteurs sensibles au vide, à la température et au temps.
 - Capteurs utilisés pour les commandes électroniques.
 - Flexibles, courroies, connecteurs, assemblages, colliers de serrage, raccords, tubes, joints ou dispositifs d'étanchéité et matériel de montage.
 - Poulies, courroies et tendeurs.
2. Vous trouverez ci-dessous la liste des pièces liées à l'évaporation couvertes par les garanties des systèmes de contrôle des émissions fédéraux et californiens. Si une pièce liée aux émissions par évaporation de vos véhicules de loisirs hors route est défectueuse, la pièce sera réparée ou remplacée par Kubota Corporation :
- a. Pièces liées aux émissions par évaporation : pour les modèles fédéraux hors Californie - deux (2) ans; pour les modèles californiens en Californie : 30 mois, environ 4000 km (2500 milles) ou 250 heures de fonctionnement, selon la première éventualité.
 - Réservoir de carburant (garantie fédérale applicable)
 - Bouchon de carburant
 - Tuyau d'alimentation en carburant
 - Raccords du tuyau d'alimentation en carburant
 - Coupleurs de carburant
 - Colliers
 - Flexibles de vapeur
 - Soupape de contrôle (2 voies)
 - Soupape de purge (**RTV-XG850 EVAP** Modèle proposé en Californie)
 - Support de réservoir (**RTV-XG850 EVAP** Modèle proposé en Californie)
 - b. Pièces liées aux émissions par évaporation à « *prix élevé* » : modèles californien en Californie : 60 mois, environ 8000 km (5000 milles), ou 500 heures de fonctionnement du moteur, selon la première éventualité.
 - Réservoir de carburant
 - Réservoir à charbon actif
 - Module de commande du moteur (ECM)