



- U.S.A. : **Kubota Tractor Corporation**
1000 Kubota Drive, Grapevine, Texas 76051, U.S.A.
Telephone : (1)-817-756-1171
- Canada : **Kubota Canada Ltd.**
1155 Kubota Drive, Pickering, Ontario L1X 0H4, Canada
Telephone : (1)-905-294-6535
- France : **Kubota Europe S.A.S.**
19-25, Rue Jules Vercurysse, Z.I., BP88 95101 Argenteuil Cedex, France
Telephone : (33)-1-3426-3434
- Italy : **KUBOTA EUROPE S.A.S Italy Branch**
Via Grandi, 29 20068 Peschiera Borrome (MI) Italy
Telephone : (39)02-51650377
- Germany : **Kubota Baumaschinen GmbH**
Steinhauser Straße 100, 66482 Zweibrücken Rheinlandpfalz, Germany
Telephone : (49)-6332-4870
- U.K. : **KUBOTA (U.K.) LTD.**
Dormer Road, Thame, Oxfordshire, OX9 3UN, U.K.
Telephone : (44)1844-214500
- Spain : **Kubota España S.A.**
Calle Fernando Alonso número 15, Leganés, 28914 (Madrid), Spain
Telephone : (34)-91-508-6442
- Turkey : **KUBOTA TURKEY MAKINE TIC.LTD.ŞTI.**
Cumhuriyet Mah. Yahya Kaptan Cad. No:3 Cayirova / Kocaeli/Turkey 41420
Telephone : (90)262-658-9045
- Australia : **KUBOTA AUSTRALIA PTY LTD.**
25-29 Permas Way, Truganina, VIC 3029, Australia
Telephone : (61)-3-9394-4400
- Malaysia : **KUBOTA MALAYSIA SDN. BHD.**
Lot 766, Jalan Subang 4, off Persiaran Subang Sungai Penaga Industrial Park,
47500 Subang Jaya
Telephone : (60)-3-7890-3533
- Philippines: **KUBOTA PHILIPPINES, INC.**
232 Quirino Highway, Baesa, Quezon City 1106, Philippines
Telephone : (63)2-422-3500
- Taiwan : **SHIN TAIWAN AGRICULTURAL MACHINERY CO., LTD.**
16, Fengping 2nd Rd, Taliaw Shiang Kaohsiung 83107, Taiwan R.O.C.
Telephone : (886)7-702-2333
- Indonesia : **PT KUBOTA MACHINERY INDONESIA**
Tower A at EightyEight@Kasablanka Lantai 16
Jalan Raya Casablanka Kav. 88, Jakarta 12870 Indonesia
Telephone : (62)-21-29568-720
- Thailand : **SIAM KUBOTA CORPORATION CO., LTD.**
101/19-24 Moo 20, Navanakorn Industrial Estate, Tambon Khlongnueng, Amphur Khlongluang,
Pathumthani 12120, THAILAND
Telephone : (66)2-909-0300
- Korea : **KUBOTA KOREA CO., LTD.**
41-27, Jayumyeok-gil, Baeksan-myeon, Gimje-si, Jeollabuk-do, Korea
Telephone : (82)-63-544-5822
- India : **KUBOTA AGRICULTURAL MACHINERY INDIA PVT. LTD.**
B 500 A & C, Indospace Industrial Park, 104 Polivakkam Village,
Sriperumbadur-Thiruvallur Main Road, Thiruvallur District-602 002.
Telephone : (91)44-4019-2000
- Vietnam : **KUBOTA VIETNAM CO., LTD.**
Lot B-3A2-CN, My Phuoc 3 Industrial Park, Thoi Hoa Ward, Ben Cat Town, Binh Duong Province, Vietnam
Telephone : (84)-274-3577-507

BA . K . 1 - 1 . . . AK

English (U.S.A.)
Code No. K3002-7125-1

OPERATOR'S MANUAL

KUBOTA ZERO TURN MOWER

MODEL Z232KW

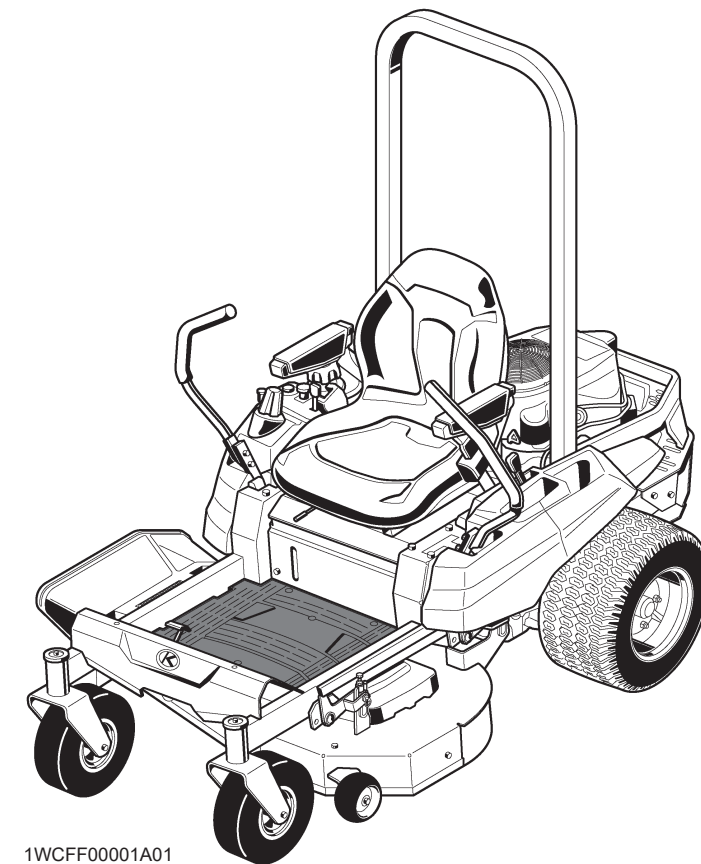

1WCFF00001A01

Z
2
3
2
K
W

READ AND SAVE THIS MANUAL



















ABBREVIATION LIST

Abbreviations	Definitions
API	American Petroleum Institute
PTO	Power Take Off
RH/LH	Right-hand and left-hand sides are determined by facing in the direction of forward travel
ROPS	Roll-Over Protective Structures
rpm	Revolutions Per Minute
SAE	Society of Automotive Engineers

UNIVERSAL SYMBOLS

As a guide to the operation of your machine, various universal symbols have been utilized on the instruments and controls. The symbols are shown below with an indication of their meaning.

- | | |
|---|---|
|  Safety Alert Symbol |  Power Take-Off Switch Control-OFF Position (DISENGAGED) |
|  Read Operator's Manual |  Power Take-Off Switch Control-ON Position (ENGAGED) |
|  Gasoline Fuel |  Hours |
|  Fuel-Level |  Cutting Height |
|  Parking Brake-ENGAGED position |  FAST |
|  Parking Brake-DISENGAGED position |  SLOW |
|  Engine-STOP |  Engine Speed Control |
|  Engine-RUN |  Choke |
|  Starter Control | |

California Proposition 65

⚠ WARNING ⚠

Engine exhaust, some of its constituents, certain vehicle components and fluids, contain or emit chemicals known to the State of California to cause cancer and birth defects or other reproductive harm.

IMPORTANT

The engine in this machine is not equipped by the manufacturer with a standard spark arrester. It is a violation of California Public Resource Code Section 4442 to use or operate this engine on or near any forest-covered, brush-covered land, or grass-covered land unless the exhaust system is equipped with a working spark arrester meeting state laws. Other states or federal areas may have similar laws.

**Canadian Electromagnetic Compatibility (EMC):
This machine complies with Industry Canada ICES-002.**

FOREWORD

You are now the proud owner of a KUBOTA ZERO TURN MOWER. This machine is a product of Kubota's quality engineering and manufacturing. It is made of excellent materials and under a rigid quality control system. It will give you long, satisfactory service. To obtain the best use of your machine, please read this manual carefully. It will help you become familiar with the operation of the machine and contains many helpful hints about machine maintenance. It is Kubota's policy to utilize, as quickly as possible, every advance in our research. The immediate use of new techniques in the manufacturing of products may cause some small parts of this manual to become outdated. Kubota distributors and dealers will have the most up-to-date information. Please do not hesitate to consult them.



SAFETY FIRST

This symbol, the industry's "Safety Alert Symbol", is used throughout this manual and on labels on the machine itself to warn of the possibility of personal injury. Read these instructions carefully. It is essential that you read the instructions and safety regulations before you attempt to assemble or use this unit.



DANGER : Indicates an imminently hazardous situation which, if not avoided, will result in death or serious injury.



WARNING : Indicates a potentially hazardous situation which, if not avoided, could result in death or serious injury.



CAUTION : Indicates a potentially hazardous situation which, if not avoided, could result in minor or moderate injury.

IMPORTANT :

Indicates that equipment or property damage could result if instructions are not followed.

NOTE :

Gives helpful information.

CONTENTS

SAFE OPERATION	5
SERVICING OF MACHINE	15
DEALER SERVICE.....	15
WARRANTY.....	15
SCRAPPING THE MACHINE.....	16
SPECIFICATIONS	17
SPECIFICATION TABLE.....	17
IMPLEMENT LIMITATIONS	19
TERMS OF USE.....	19
INSTRUMENT PANEL AND CONTROLS	20
INSTRUMENT PANEL, SWITCHES AND HAND CONTROLS.....	20
MOWER.....	21
MOWER MOUNTING	22
MOUNTING THE MOWER DECK.....	22
ADJUSTING THE MOWER.....	23
DISMOUNTING THE MOWER DECK.....	23
OPERATING THE ENGINE	24
GETTING ON AND OFF THE MACHINE SAFELY.....	24
STARTING THE ENGINE.....	24
1. Choke knob.....	25
2. Throttle lever.....	25
3. Key switch.....	26
STOPPING THE ENGINE.....	26
CHECK DURING OPERATING.....	26
1. Fuel gauge.....	26
2. Hour meter.....	27
COLD WEATHER STARTING.....	27
WARMING UP THE ENGINE.....	27
1. Warm-up and transmission oil in the low temperature range.....	27
JUMP STARTING.....	27
OPERATING THE MACHINE	29
OPERATING A NEW MACHINE.....	29
1. Changing lubricating oil for new machine.....	29
2. Burnishing PTO clutch.....	30
STARTING THE MACHINE.....	30
1. Operator's seat.....	30
2. Seat belt.....	31
3. Mower lift pedal.....	31
4. Throttle lever.....	31
5. Parking brake lever.....	31
6. Motion control lever.....	31
6.1 Stop position of the motion control lever.....	32
6.2 Operating position of the motion control lever.....	32
6.3 Adjustment of the motion control lever.....	33
STOPPING THE MACHINE.....	33
PARKING THE MACHINE.....	34
TRANSPORTING THE MACHINE.....	34
1. Hydrostatic transaxle bypass rods.....	34
ACCESSORY.....	35

1. Accessory electrical outlet	35
OPERATING THE MOWER.....	36
MOWING TIPS.....	36
ADJUSTING THE CUTTING HEIGHT	36
OPERATING THE MOWER.....	37
1. PTO switch	38
2. Starting the machine.....	38
TIRES AND WHEELS.....	39
TIRES.....	39
1. Inflation pressure	39
WHEELS	39
1. Installing the rear wheels.....	39
2. Removing the front caster wheels	39
3. Installing the front caster wheels	40
MAINTENANCE.....	41
SERVICE INTERVALS.....	41
LUBRICANTS AND FUEL.....	42
PERIODIC SERVICE	43
RAISING AND LOWERING THE OPERATOR'S SEAT	43
DAILY CHECK	43
1. Checking the engine oil level.....	44
2. Checking the amount of fuel and refueling	44
3. Checking and cleaning the air intake screen.....	45
4. Checking the tire pressure.....	45
4.1 Inflation pressure.....	46
5. Checking movable parts	46
EVERY 50 HOURS	46
1. Checking the engine start system	46
2. Checking the OPC system	47
3. Checking the muffler and spark arrester (if equipped).....	47
EVERY 100 HOURS	48
1. Changing the engine oil.....	48
2. Cleaning the air cleaner paper element.....	49
3. Cleaning the engine cooling system.....	49
4. Checking the spark plug	50
5. Checking the fuel filter	50
6. Checking the battery condition	51
6.1 Non-accessible maintenance-free type batteries	51
6.2 Checking the battery voltage.....	51
6.3 Charging the battery.....	51
6.4 Storing the battery	52
7. Adjusting the throttle cable	52
8. Adjusting the choke cable.....	52
EVERY 200 HOURS	52
1. Replacing the engine oil filter	52
2. Replacing the air cleaner paper element.....	53
EVERY 300 HOURS	54
1. Cleaning the combustion chamber	54
2. Checking the valve seats and clearance	54
EVERY 1 YEAR	54
1. Checking the battery condition	54
2. Checking fuel lines	54
3. Checking the muffler and spark arrester (if equipped).....	55
4. Changing the engine oil	55
EVERY 4 YEARS.....	55

1. Replacing the fuel lines	55
SERVICE AS REQUIRED.....	55
1. Replacing fuses	55
2. Checking and replacing blades	56
3. Replacing the mower belt	57
4. Adjusting the electric clutch	57
ADJUSTMENT	58
MOTION CONTROL LEVER	58
1. Adjusting HST neutral position	58
2. Adjusting maximum speed (forward)	58
3. Motion control lever alignment.....	58
3.1 Checking the alignment.....	58
3.2 Aligning the motion control levers	58
MOWER DECK LEVEL.....	59
1. Anti-scalp rollers	59
2. Leveling the mower deck (side-to-side).....	59
2.1 Checking the level (side-to-side).....	59
2.2 Adjusting the level (side-to-side).....	60
3. Leveling the mower deck (front-to-rear)	60
3.1 Checking the level (front-to-rear)	60
3.2 Adjusting the level (front-to-rear).....	60
GENERAL TIGHTENING TORQUE SPECIFICATION	62
STORAGE.....	63
STORING THE MACHINE.....	63
REMOVING THE MACHINE FROM STORAGE.....	63
TROUBLESHOOTING	64
ENGINE TROUBLESHOOTING	64
BATTERY TROUBLESHOOTING.....	66
MACHINE TROUBLESHOOTING	66
MOWER TROUBLESHOOTING.....	67
INDEX.....	69

SAFE OPERATION

Careful operation is your best insurance against an accident.

The owner/user can prevent and is responsible for accidents or injuries occurring to themselves, other people or property. Read and understand this manual carefully before operating the machine. All operators, no matter how much experience they may have had, must read and understand this and other related manuals before operating the machine or any implement attached to it. It is the owner's obligation to instruct all operators in safe operation.

If the operator(s) or mechanic(s) cannot understand the contents, it is the owner's responsibility to explain this material to them. This mowing machine is capable of amputating hands, feet and throwing objects. Failure to observe the following safety instructions could result in serious injury or death.

BEFORE OPERATING THE MACHINE

Know your equipment and its limitations. Read all instructions in this manual and machine safety labels before attempting to start and operate the machine.

1. General

- The zero turn mowing machine has different steering characteristics than other machines with a steering wheel and does not have a service brake pedal (but, has a parking brake lever. Normal slowing down and stopping is done with the motion control levers.). Read and understand the Operator's Manual before operating the machine. Practice operating the machine at low engine speed in an unobstructed area without engaging the mower.
- Pay special attention to the safety labels on the machine itself.
- Do not allow any bystanders around or near the machine during operation.
- Do not allow passengers, children or non-qualified operators on the machine at any time. The operator must remain in the machine seat throughout operation.
- Do not operate the machine or any attachments while under the influence of alcohol, medication, controlled substances or when fatigued.
- Do not wear loose, torn, or bulky clothing around the machine. The clothing may catch on moving parts or controls, leading to the risk of an accident. Wear and use any additional safety items such as a hard hat, safety boots or shoes, eye and hearing protection, gloves and so on, as appropriate or required.
- Do not wear radio or music headphones while operating the machine.
- Do not operate the machine or any attachments while using or texting with a cellphone or any other electronic device.
Safe operation requires your full attention.
- Carefully check the vicinity before operating machine or any implement attached to it. Clear the work area of objects (such as wires and rocks) that might be picked up and thrown. Check for overhead clearance which may interfere with the grass catcher or ROPS.
- Check brakes and other mechanical parts for correct adjustment and wear. Replace worn or damaged parts promptly. Check the tightness of all nuts and bolts regularly.
(See PERIODIC SERVICE on page 43 and ADJUSTMENT on page 58.)
- Keep all shields and guards in place. Replace any that are damaged or missing.
- Before allowing other people to use your machine, explain how to operate and have them read this manual before operation.
- In addition to the design and configuration of equipment, hazard control and accident prevention are dependent upon the awareness, concern and prudence of personnel involved in the operation, transport and maintenance of the equipment.
- Keep the machine and attachments in good operating condition and keep safety devices in place and in proper working condition.
- Do not modify the machine. Unauthorized modification may affect the function of the machine, which may result in personal injury.
- Do not make any modifications to the engine or emission components as they may result in damage and malfunctions such as:
 - Damage to the power train from excessive engine output.
 - Engine overheating caused by exceeding the engine cooling performance capabilities.
 - Malfunctions of the exhaust gas aftertreatment control devices.Modifications to the engine and its emission components may violate emission regulations and are subject to fines and penalties. Kubota and its affiliates are not liable for any damage, malfunction or accidents caused by modifications to the engine or emission components.

SAFE OPERATION

- Use only implements approved by Kubota. Use proper ballast on the front or rear of the machine to reduce the risk of upsets. Follow the safe operating procedures specified in the manuals of the equipment.
- Keep your machine clean. Accumulations of dirt, grease, and trash can contribute to fires and lead to personal injury.
- The exhaust gas from the muffler is very hot. To prevent fire, do not expose dry grass, mowed grass, oil and any other combustible materials to the exhaust gas. Use a spark arrester where required. Keep the engine and muffler clean all the times.

2. ROPS

- Kubota recommends the use of a roll-over protective structure (ROPS) and seat belt in almost all applications. This combination will reduce the risk of serious injury or death, should the machine be upset.
- If the ROPS is loosened or removed for any reason, make sure that all parts are reinstalled correctly before operating the machine.
- Never modify or repair a ROPS because welding, bending, drilling, grinding, or cutting may weaken the structure.
- If any structural member of the ROPS is damaged, replace the entire structure at your local Kubota Dealer.
- Always use the seat belt if the machine has a ROPS. Check the seat belt regularly and replace if frayed or damaged.

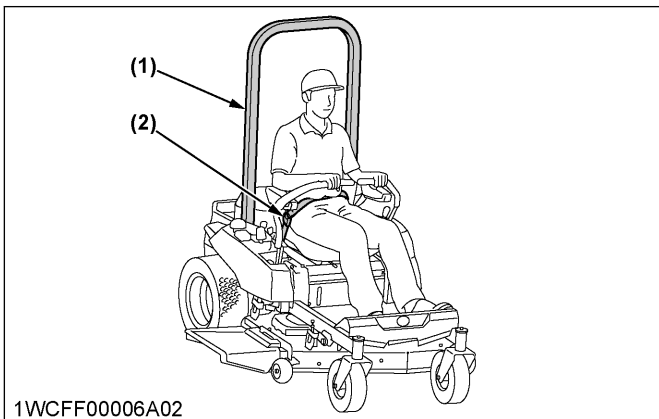

- (1) ROPS
(2) Seat belt

OPERATING THE MACHINE

1. Starting to operate the machine

- Always sit in the operator's seat when starting the engine or operating levers or controls.

- Before starting the engine make sure that the motion control levers are in "NEUTRAL LOCK", the parking brake is applied, and the power take-off (PTO) is disengaged (OFF).
- Do not start the engine by shorting across starter terminals. The machine may start in gear and move if the normal starting circuitry is bypassed.
- Do not operate or idle the engine in a non-ventilated area. Carbon monoxide gas is colorless, odorless, and deadly.
- Do not start the engine when the front or rear tires are not on the ground.
- Check before each use that the operator presence control (OPC) system is functioning correctly. Test the safety systems. (See Checking the engine start system on page 46 and Checking the OPC system on page 47.) Do not operate unless they are functioning correctly.
- Check all fluids before starting.

2. Working the machine

- Do not turn sharply when driving at high speed.
- To avoid tip-over accidents, slow down when turning on uneven terrain or before stopping.
- Do not operate near ditches, holes, embankments, or other terrain, which may collapse under the machine's weight. The risk of machine tip-overs increases when the ground is loose or wet.
- Park the machine on a firm and level surface.
- Before you get off, apply the parking brake, place the motion control levers in their "NEUTRAL LOCK" positions, disengage the PTO, lower all attachments to the ground, turn off the engine, and remove the key.
- Watch where you are going at all times. Watch for and avoid obstacles. Be alert at curbs, near trees, and other obstructions and hidden hazards.
- Know what is behind you before backing up. Look to the rear before and when backing. Do not mow while in reverse unless absolutely necessary and make sure the area immediately behind you is clear of obstructions or holes and small children. Use extra caution when the machine is equipped with a grass catcher as your view to the rear is restricted.
- When working in groups, always let others know what you are doing ahead of time.
- Do not drive the machine on streets or highways. Watch for traffic when you cross roads or operate near roads.
- Be aware of the mower discharge direction and do not point it at anyone. Never operate with the discharge deflector raised, removed or altered, unless using a grass catcher.
- When using any attachments, never direct discharge material toward bystanders. Do not allow

people or pets near the attachments while in operation.

Do not mow when bystanders are present in the mowing area.

- To reduce fire hazards, keep the engine exhaust area free of grass or leaves.
- Be sure that the rotating blades and the engine are stopped and the key is removed before placing hands or feet near blades and cleaning blockages or unclogging the discharge deflector.
- Shut the engine off and wait for all movement to stop before removing the grass catcher or unclogging the discharge deflector.
- Maintain all screens to avoid overheating conditions.
- Always inspect the mower for damage after striking a foreign object. Repair or replace any damaged parts before restarting.
- Operate during daylight or in bright artificial light.

3. Safety for children

Tragic accidents can occur if the operator is not alert of the presence of children. Children are attracted to the machine and mowing activity.

- Never assume that children will remain where you last saw them.
- Keep children out of the mowing area and under the watchful care of another responsible adult.
- Be alert and turn the machine off if children enter the area.
- Before and when backing, look behind and down for small children.
- Never carry children. There is no safe place for them to ride. They may fall off and be seriously injured or interfere with safe machine operation.
- Never allow children to operate the machine, even under adult supervision.
- Use extra care when approaching blind corners, shrubs, trees, or other obstructions that might hide children from sight.
- Do not mow in reverse. Operate in reverse with the blades engaged only when it is absolutely necessary and make sure that the area to the rear is clear of children before doing so.

4. Operators, age 60 years and older

Data indicates that operators, age 60 years and older, are involved in a large percentage of machine-related injuries. These operators should evaluate their ability to operate the machine safely enough to protect themselves and others from serious injury.

5. Operating on slopes

Slopes are a major factor related to loss-of-control and tip-over accidents, which can result in severe injury or death. All slopes require extra caution.

If you cannot back up the slope or if you feel uneasy on it, do not mow it.

If the engine stops when operating on a slope, apply the parking brake immediately to prevent machine runaway.

Do

- To avoid tip-over accidents, operate across slopes, not up and down. Stay off hills and slopes too steep for safe operation.
- Remove obstacles such as rocks and tree limbs.
- Stay alert for holes in the terrain and other hidden hazards. Keep away from drop-offs. Uneven terrain could overturn the machine. Tall grass can hide obstacles.
- Follow the manufacturer's recommendations for wheel weight or counterweights to improve stability.
- Keep all movement on slopes slow and gradual. Do not make sudden changes in speed or direction.
- Avoid starting or stopping on a slope. If tires lose traction, disengage PTO and proceed slowly straight down the slope.
- Reduce the speed and exercise extreme caution on slopes and in sharp turns to prevent tip-over accidents or loss of control.
- Use special caution when changing direction on slopes. Slow down, and use extra caution when changing direction on a slope.

Do not

- Do not turn on slopes unless necessary. If necessary, turn uphill slowly and gradually.
- Do not mow near drop-offs, ditches, or embankments. The mower could suddenly turn over if a wheel is over the edge of cliff or ditch, or if an edge caves in.
- Do not mow on wet grass. Reduced traction could cause sliding and loss of control.
- Do not try to stabilize the machine by putting your foot on the ground.
- Do not use the grass catcher on steep slopes.
- Do not start or stop suddenly when going uphill or downhill. Avoid sudden start and stops on slopes.
- Never “freewheel”. Do not let the machine travel downhill with motion control levers at the “NEUTRAL LOCK” position or in “NEUTRAL”.
- Do not operate the machine without the mower deck installed.

6. Stopping the machine

- Park the machine on level ground.
- Make sure that the machine and all attachments have come to a complete stop before you get off.

SAFE OPERATION

- Before you get off, apply the parking brake, place the motion control levers in their “NEUTRAL LOCK” positions, disengage the PTO, lower all attachments to the ground, turn off the engine, and remove the key.
- Do not park the machine on dry grass or leaves.

TRANSPORTING THE MACHINE

- Disengage power to attachment(s) when transporting or not in use.
- Do not tow this machine. Use a suitable truck or trailer when transporting on public roads.
- Use extra care when loading or unloading the machine into a trailer or truck.
- This machine is not allowed to be used on public roads.

SERVICING AND STORAGE

1. Servicing the machine

- Before servicing, park the machine on a firm, level surface and apply the parking brake. Remove the key to prevent an accidental start-up.
- Allow the machine time to cool before touching the engine, muffler and so on.
- Always stop the engine before refueling. Avoid spills and overfilling.
- If fuel is spilled, do not attempt to start the engine and avoid creating any source of ignition until fuel vapors have dissipated.

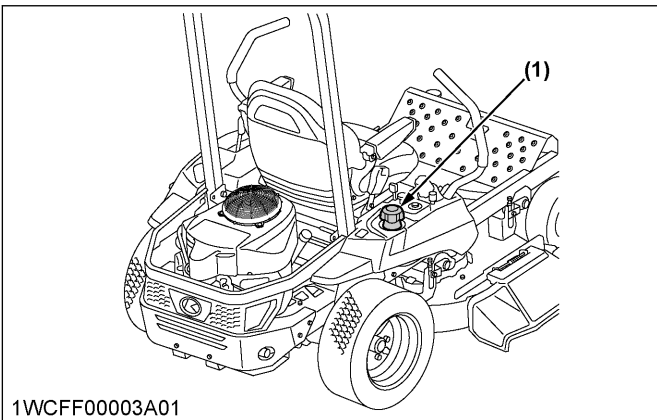

(1) Fuel tank cap

- Use extra care when handling gasoline fuels. They are flammable.
 1. Use only an approved container.
 2. Do not remove the fuel cap or refuel with the engine running. Allow the engine to cool before refueling. Do not smoke while refueling or when standing near fuel.
 3. Do not refuel the machine indoors and always clean up spilled fuel or oil.

4. Do not store the machine or fuel container inside where there is an open flame, such as in a water heater.

- Do not smoke when working around battery or when refueling. Keep all sparks and flames away from battery and fuel tank.

A battery, especially when charging, will give off hydrogen and oxygen gases, which can explode and cause serious personal injury.

- Before “jump starting” a dead battery, read and follow all the instructions.
- Disconnect the battery's ground cable before working on or near electric components.
- Do not use or charge the refillable type battery if the fluid level is below the **[LOWER]** (lower limit level) mark. Otherwise, the battery component parts may prematurely deteriorate, which may shorten the battery's service life or cause an explosion. Check the fluid level regularly and add distilled water as required so that the fluid level is between the **[UPPER]** and **[LOWER]** levels.
- Keep a first aid kit and fire extinguisher handy at all times.
- Do not attempt to mount a tire on a rim unless qualified to do so and all proper safety precautions are followed.
- Always maintain the correct tire inflation pressure. Do not inflate tires above the recommended pressure shown in the Operator's Manual.

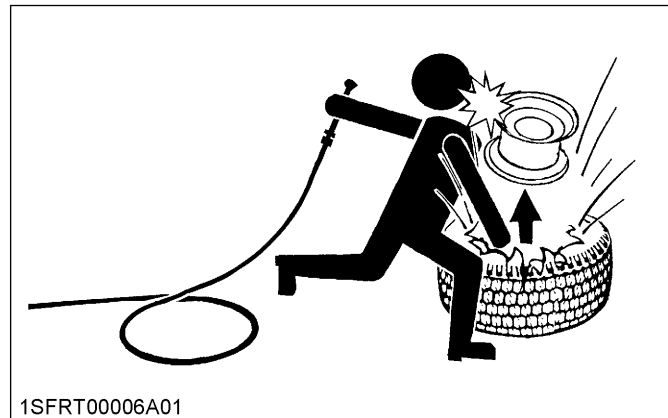

- Provide adequate support when changing wheels.
- Make sure that wheel nuts and bolts have been tightened to the specified torque.
- Do not make adjustments or repairs with the engine running.
- Keep the machine free of grass, leaves, or other debris build-up.
- Do not change the engine governor setting or overspeed the engine.
- Do not run the machine inside a closed area.
- Mower blades are sharp and can cut your hands. Wrap the blade(s) or wear gloves, and use extra caution when servicing them.
- Keep nuts and bolts, especially blade attachment bolts, tight and keep equipment in good condition.

⚠️ SAFE OPERATION

SAFETY LABELS

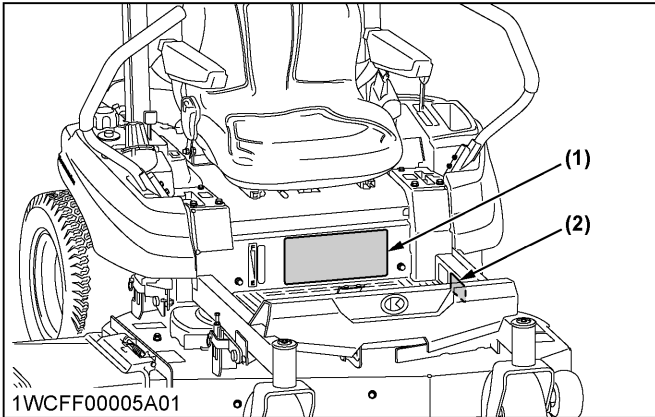

(1) Part No. K3001-6542-1

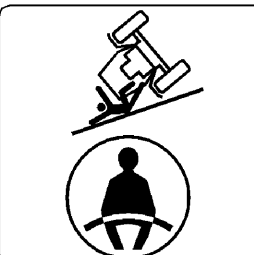
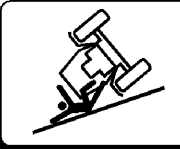
<p>⚠️ WARNING</p> 	<p>⚠️ WARNING</p> <p>TO AVOID SERIOUS INJURY OR DEATH</p> <ol style="list-style-type: none">1. Mow across slopes - Not up and down.2. Use extreme caution when operating on slopes.3. Loss of traction may occur when operating on slopes.4. Drive slowly on slopes.5. Do not operate on wet slopes.6. Avoid sudden starts.7. Execute turns slowly. 	<p>⚠️ WARNING</p> <p>TO AVOID SERIOUS INJURY</p> <ol style="list-style-type: none">1. Read and understand the operator's manual before operation.2. Do not operate this machine unless you are trained.3. Before allowing other people to use the machine, have them read the operator's manual.4. Check the tightness of all nuts and bolts regularly.5. Before starting the engine, make certain that everyone is at a safe distance from the machine, PTO is disengaged and motion control levers are in neutral lock.6. Remove objects that could be thrown by the blade.7. Do not operate the machine when children and/or others are around.8. Do not carry children or others on the machine at any time.9. Before dismounting, disengage PTO clutch, lower the implement, place motion control levers in neutral lock position, set the parking brake, stop the engine and remove the key.10. Keep safety devices (guards, shields and switches) in place, and working.11. To reduce the fire hazard, keep the exhaust clear of dry grass, dry leaves or other combustible materials.12. This machine is not for street or highway use.13. Securely support the machine and implement before working underneath.14. Look down and behind before and while backing.
<p>TO AVOID SERIOUS INJURY OR DEATH</p> <ol style="list-style-type: none">1. Do not remove Roll-Over Protective Structures (ROPS) for any application.2. Do not modify or repair a ROPS because welding, grinding, drilling or cutting any portion may weaken the structure.3. Fasten SEAT BELT before operating.	<p>⚠️ WARNING</p> <p>TO AVOID SERIOUS INJURY OR DEATH</p> <ol style="list-style-type: none">1. Park the machine on level ground.2. If necessary to park on an incline,<ol style="list-style-type: none">① Stop the machine.② Apply the parking brake.③ Stop the engine.If you stop the engine on an incline without applying the parking brake, the machine could move and run away.3. If the engine stops suddenly during operation, apply the parking brake immediately to prevent machine runaway.	

(2) Part No. K1025-6595-1

California Proposition 65

⚠️ WARNING ⚠️

Engine exhaust, some of its constituents, certain vehicle components and fluids, contain or emit chemicals known to the State of California to cause cancer and birth defects or other reproductive harm.

1WCFF00039A01enUS

! SAFE OPERATION

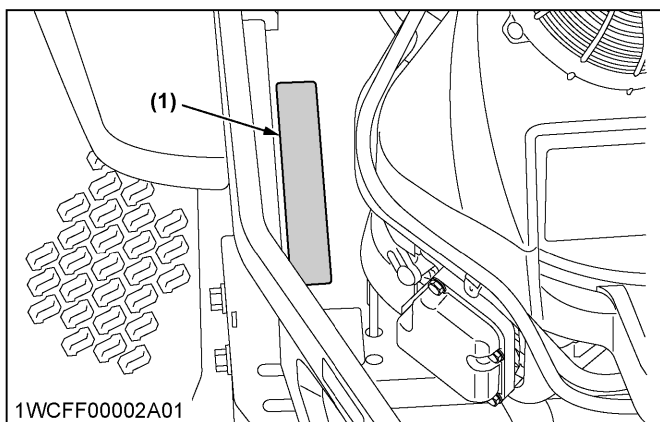

(1) Part No. K3001-6541-1



TO AVOID POSSIBLE INJURY OR DEATH FROM A MACHINE RUNAWAY.

1. Do not start engine by shorting across starter terminals or bypassing the safety start switch. Machine may start in gear and move if normal starting circuitry is bypassed.
2. Start engine only from operator's seat with motion control levers in neutral lock position and PTO OFF. Never start engine while standing on the ground.

(2) Part No. K3011-6584-1

- Gasoline fuel only
- No fire



(4) Part No. K3001-6548-1

- Hot surface - Burn to finger or hand
- Do not touch muffler.

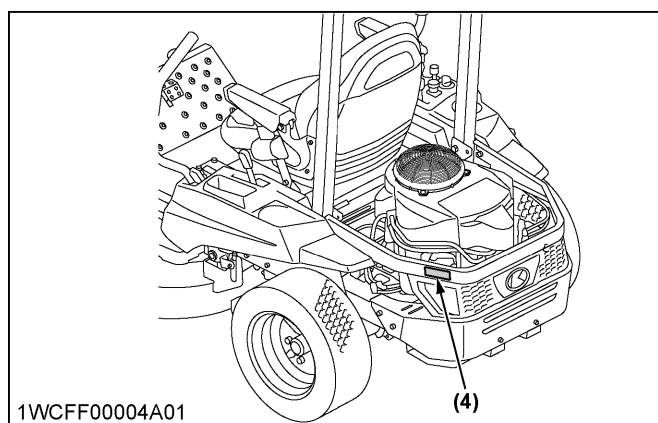
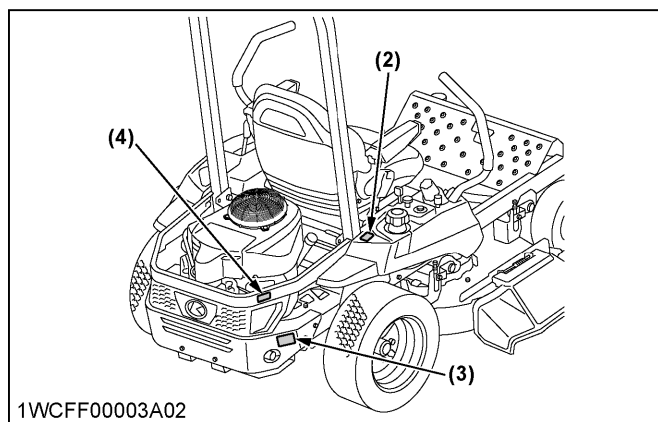
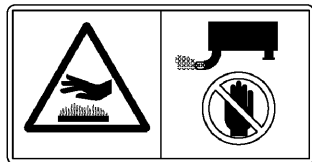

(3) Part No. K3011-6543-1



1WCFF00040A01enUS

⚠️ SAFE OPERATION

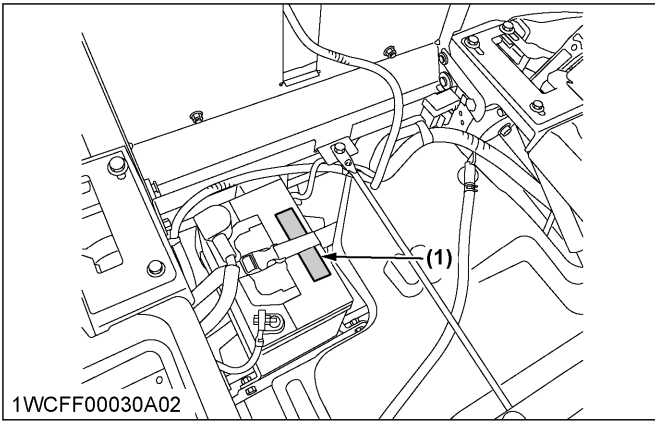

(1) Part No. K3011-6118-4

FLAMMABLES SHIELD EYES KEEP OUT OF THE REACH OF CHILDREN CAUTIOUS OF SULFURIC ACID READ INSTRUCTION MANUAL CAREFULLY EXPLOSIVE	<p>DANGER EXPLOSIVE GASES CIGARETTES, FLAMES OR SPARKS COULD CAUSE BATTERY TO EXPLODE. ALWAYS SHIELD EYES AND FACE FROM BATTERY. DO NOT CHARGE OR USE BOOSTER CABLES OR ADJUST POST CONNECTIONS WITHOUT PROPER INSTRUCTION AND TRAINING.</p> <p>POISON CAUSES SEVERE BURNS CONTAINS SULFURIC ACID. AVOID CONTACT WITH SKIN, EYES OR CLOTHING. IN EVENT OF ACCIDENT FLUSH WITH WATER AND CALL A PHYSICIAN IMMEDIATELY.</p> <p>KEEP OUT OF REACH OF CHILDREN</p> <p>California Proposition 65 WARNING : This product can expose you to chemicals including lead, which is known to the State of California to cause cancer and birth defects or other reproductive harm. For more information go to www.P65Warnings.ca.gov.</p>	<p>SMF U1-300 PART No. K3011-61144</p> <table border="1"> <tr> <td>NOMINAL VOLTAGE</td> <td>12V</td> </tr> <tr> <td>COLD CRANKING AMPS</td> <td>300</td> </tr> <tr> <td>CRANKING AMPS</td> <td>410</td> </tr> <tr> <td>RESERVE CAPACITY(MINUTES)</td> <td>45</td> </tr> <tr> <td>AMP HOURS(@20 hr Rate)</td> <td>29</td> </tr> </table>	NOMINAL VOLTAGE	12V	COLD CRANKING AMPS	300	CRANKING AMPS	410	RESERVE CAPACITY(MINUTES)	45	AMP HOURS(@20 hr Rate)	29
	NOMINAL VOLTAGE	12V										
COLD CRANKING AMPS	300											
CRANKING AMPS	410											
RESERVE CAPACITY(MINUTES)	45											
AMP HOURS(@20 hr Rate)	29											
<p>FITTING DATE</p> <p>0 1 2 3 4 5 6 7 8 9 YEAR</p> <p>1 2 3 4 5 6 7 8 9 10 11 12 MONTH</p>		<p>MADE IN KOREA</p>										

TO AVOID INJURY FROM BATTERY GASES AND ACIDES

- Keep away cigarettes, flames or sparks.
- Always shield eyes and face from battery.
- Keep out of reach of children.
- Poison causes severe burns.
• Contains sulfuric acid.
- Read and understand operator's manual.
- Danger explosive gases.

1BDABDYAP096A

1WCFF00041A01enUS

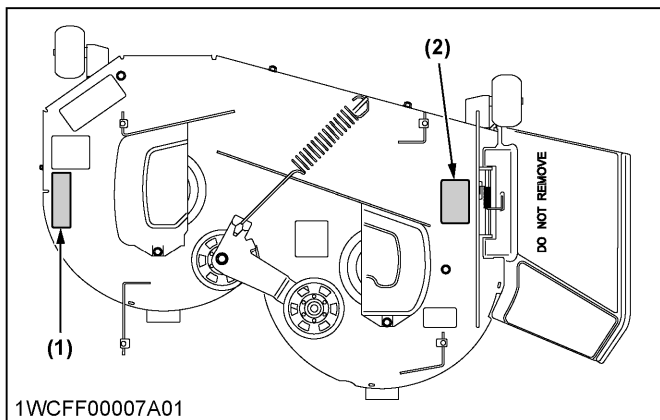

(1) Part No. K5617-7311-1



(2) Part No. K5617-7312-1



1WCFF00042A01enUS

CARE OF SAFETY LABELS

- Keep safety labels clean and free from obstructing material.
- Clean safety labels with soap and water, and dry with a soft cloth.
- Replace damaged or missing safety labels with new labels from your local Kubota Dealer.
- If a component with safety label(s) attached is replaced with a new part, make sure new label(s) is (are) attached in the same location(s) as the replaced component.
- Attach new safety labels by applying on a clean dry surface and pressing any bubbles to the outside edge.

SERVICING OF MACHINE

DEALER SERVICE

After reading this manual thoroughly, you will find that you can do some of the regular maintenance yourself. Your dealer has knowledge of your new machine and has the desire to help you get the best performance and the most value from it.

However, when in need of parts or major service, consult your local Kubota Dealer. When in need of parts, be prepared to give your dealer the product identification number (PIN), and the ROPS, engine and mower serial numbers.

Locate the PIN and serial numbers now, and record them in the space provided.

Date of purchase		
Name of dealer		
Machine type		
Product identification number		
	Type	Serial number
ROPS		
Engine		
Mower		

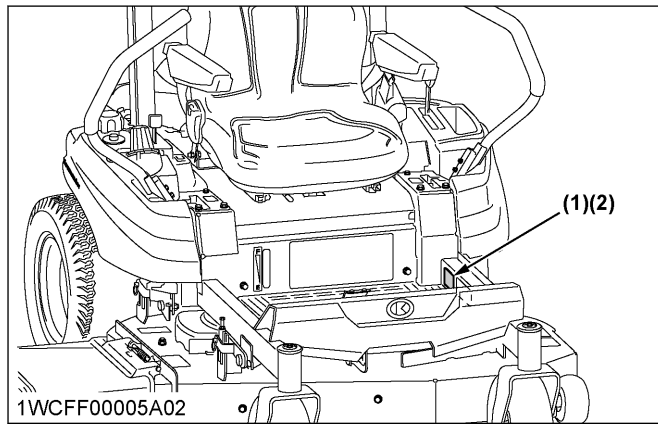

(1) Machine identification plate
(2) Product identification number

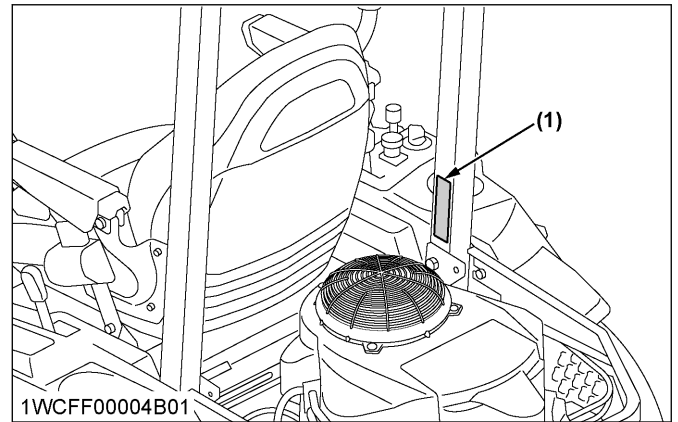

(1) ROPS serial number

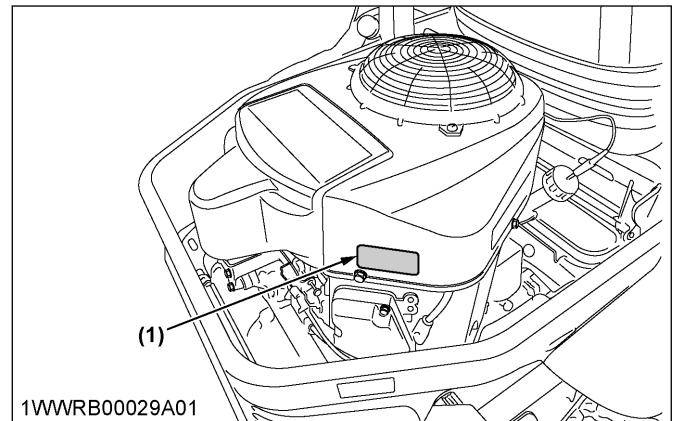

(1) Engine serial number

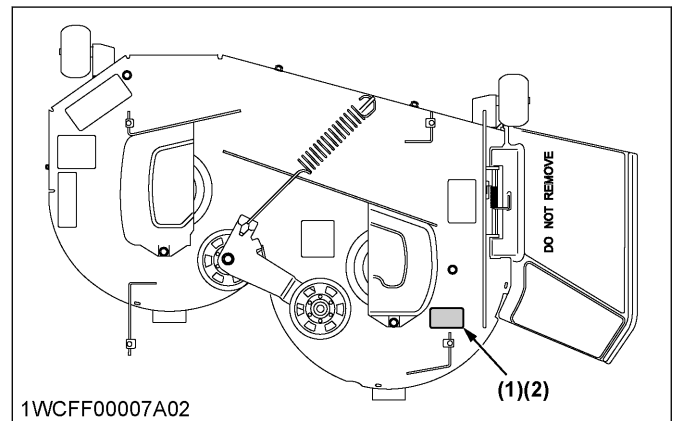

(1) Mower identification plate
(2) Mower serial number

WARRANTY

This machine is warranted under the **Kubota Limited Express Warranty**, a copy of which may be obtained from your selling dealer. No warranty shall, however, apply if the machine has not been handled according to

the instructions given in the Operator's Manual, even if it is within the warranty period.

SCRAPPING THE MACHINE

To put the machine out of service, correctly follow the local rules and regulations of the country or territory where you scrap it. If you have questions, consult your local Kubota Dealer.

SPECIFICATIONS

SPECIFICATION TABLE

Model			Z232KW	
Engine	Model name		FR651	
	Max. engine power (gross)	kW (HP)	16.0 (21.5) ^{*1*2}	
	Type		Air-cooled gasoline engine	
	Number of cylinders		2 (V-Twin)	
	Bore and stroke	mm (in.)	78 × 76 (3.07 × 2.99)	
	Total displacement	cm ³ (cu. in.)	726 (44.3)	
	Rated revolution	rpm	3600	
	Fuel		Unleaded gasoline	
	Starter		Electric	
	Lubrication		Full pressure lubrication	
	Cooling		Air-cooled	
	Battery		U1 (12 V, RC: 45 min, CCA: 300, CA: 410)	
Capacities	Fuel tank	L (U.S.gals.)	13.6 (3.6)	
	Engine crankcase (with filter)	L (U.S.qts.)	2.1 (2.2)	
	Transmission case including rear axle gear case	L (U.S.qts.)	1.513 to 1.588 (1.599 to 1.678) ^{*3}	
Dimensions	Overall length		mm (in.)	1890 (74.4)
	Overall width without mower deck		mm (in.)	1076 (42.4)
	Overall height (with ROPS)		mm (in.)	1693 (66.7)
	Wheelbase		mm (in.)	1236 (48.7)
	Min. ground clearance		mm (in.)	104 (4.1)
	Tread	Front	mm (in.)	616 (24.3)
Rear		mm (in.)	885 (34.8)	
Weight (with fuel, with mower deck)		kg (lbs.)	292 (643)	
Traveling system	Tires	Front	11 × 4 - 5 (4PR) smooth	
		Rear	18 × 7.5 - 10 (4PR)	
	Traveling speeds	Forward	mph (km/h)	6.5 (10.5)
		Reverse	mph (km/h)	4 (6.4)
	Steering		2 - hand levers	
	Transmission		2 - HST with gear	
	Parking brake		Hand lever applied, released	
	Min. turning radius	mm (in.)	0 (0)	
PTO	Drive system		Belt	
	Clutch type		Electric	

Specifications and design subject to change without notice.

*1 Manufacturer's estimate

*2 These Kawasaki engines have been tested in accordance with SAE J1995, verified by TÜV Rheinland Group, and certified by SAE International. The gross power ratings of these engines were determined by using measurements according to SAE J1995 which were witnessed by SAE-approved witnesses from TÜV Rheinland Group. Torque ratings of these engines were not certified by SAE. Actual power and torque output will vary depending on numerous factors, including, but not limited to, the operating speed of the engine in application, environmental conditions, maintenance, and other variables.

SPECIFICATIONS

*3 Oil amount when the oil level is at the upper level.

Model			RCK42P-122Z
PRO commercial deck (fabricated deck)	Suitable machine		Z232KW
	Mounting method		Parallel linkage
	Adjustment of cutting height		Dial gauge
	Cutting width	mm (in.)	1067 (42)
	Cutting height	mm (in.)	38.1 to 108 (1.5 to 4.25)
	Weight (approximation)	kg (lbs.)	45.3 (100)
	Blade spindle speed	r/s (rpm)	52.2 (3133) *1
	Blade tip velocity	m/s (fpm)	89.8 (17700) *1
	Blade length	mm (in.)	548 (21.6)
	Number of blades		2
	Dimensions	Total length	mm (in.)
Total width		mm (in.)	1401 (55.2)
Total height		mm (in.)	293.5 (11.6)

*1 Engine maximum rpm

IMPLEMENT LIMITATIONS

TERMS OF USE

The Kubota Machine has been thoroughly tested for proper performance with implements sold or approved by Kubota.

Use with implements below may result in malfunctions or failures of the machine, damage to other property and injury to the operator or others.

- Implements which are not sold or approved by Kubota
- Implements which exceed the maximum specifications listed below, or
- Implements which are otherwise unfit for use with the Kubota Machine

Any malfunctions or failures of the machine resulting from use with improper implements are not covered by the warranty.

Weight limit table

Unit	Maximum loading weight		Implement weight W_a	Maximum total weight
	Front axle W_f	Rear axle W_r		
Z232KW	83 kg (184 lbs.)	362 kg (798 lbs.)	50 kg (110 lbs.)	445 kg (982 lbs.)

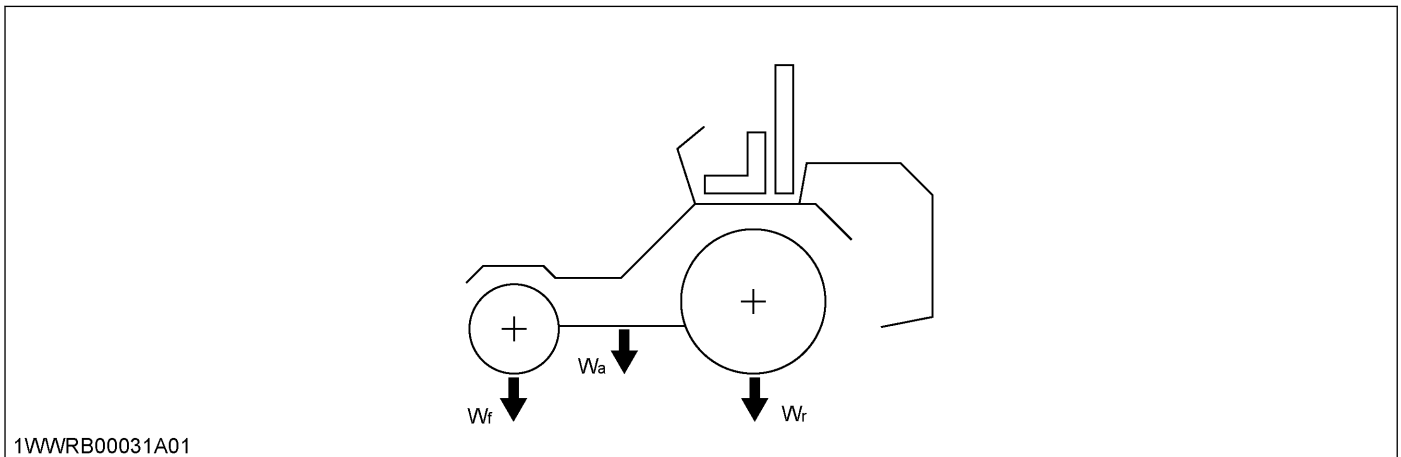

NOTE :

- These limits include operator weight with seat in rearmost position.

INSTRUMENT PANEL AND CONTROLS

INSTRUMENT PANEL, SWITCHES AND HAND CONTROLS

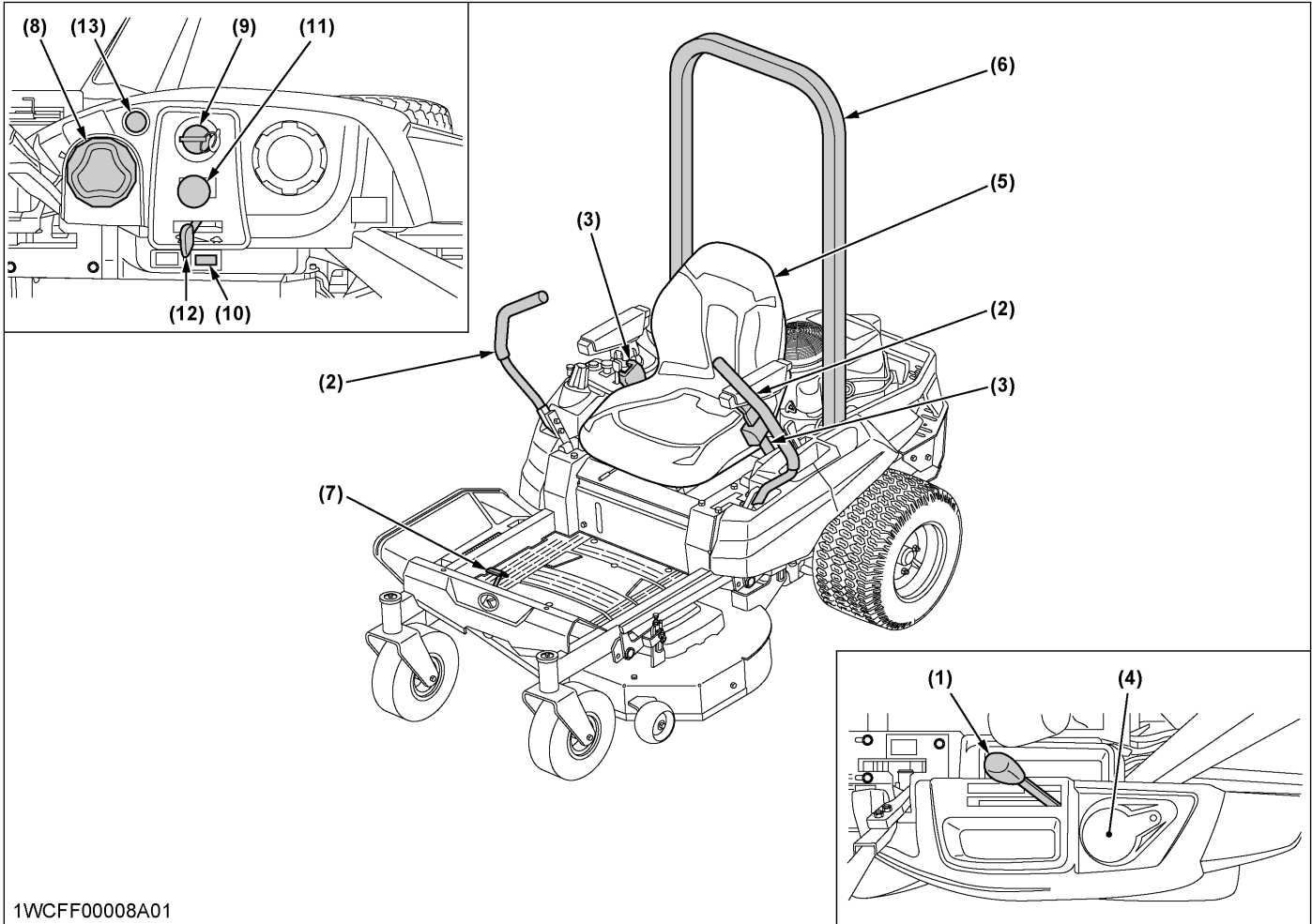

1WCFF00008A01

(1) Parking brake lever.....	24	(4) Cup holder		(9) Key switch.....	26
Parking brake lever.....	31	(5) Operator's seat.....	30	(10) Hour meter.....	27
(2) Motion control lever.....	24	(6) ROPS		(11) PTO switch.....	38
Motion control lever.....	31	(7) Mower lift pedal.....	31	(12) Throttle lever.....	31
(3) Seat belt.....	31	(8) Cutting height control dial.....	36	(13) Choke knob.....	25

MOWER

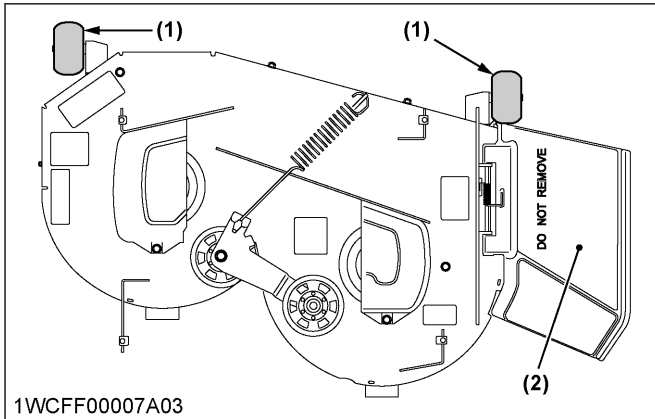

(1) Anti-scalp roller (front, bolt shift type)	36
(2) Discharge deflector	37

MOWER MOUNTING

MOUNTING THE MOWER DECK

WARNING

To avoid serious injury or death:

- Park the machine on a firm and level surface.
- Apply the parking brake.
- Stop the engine and remove the key.

1. Before mounting the mower deck, raise the lift links to the highest cutting position (4.25 in.).
2. Change the direction of the front tires as shown in the figure.
3. Place the mower deck at the right side of the machine.

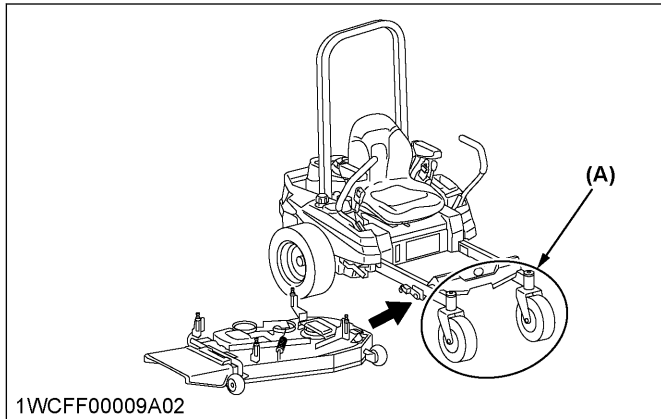

(A) Direction of front tires

4. Slide the mower deck under the machine, then lower the mower lift links to the lowest cutting position (1.5 in.).
5. Attach the lift links to the mower deck with attaching hardware.

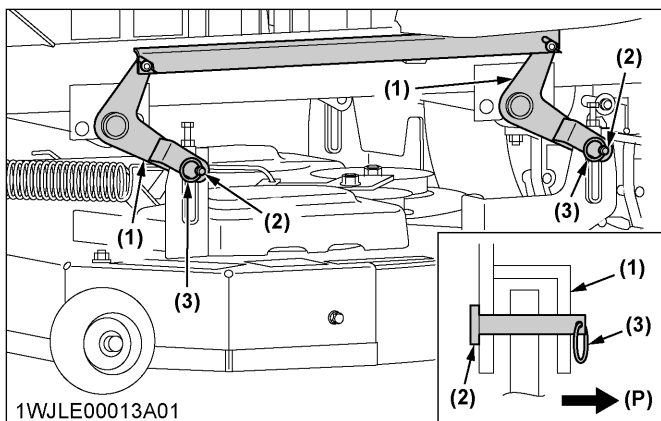

- (1) Lift link
- (2) Clevis pin
- (3) Snap ring
- (P) Out side

6. Attach the mower belt to the clutch pulley. Refer to the belt routing as follows.

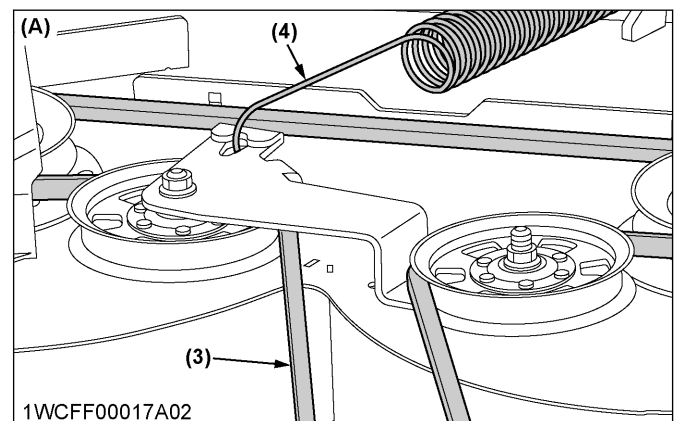
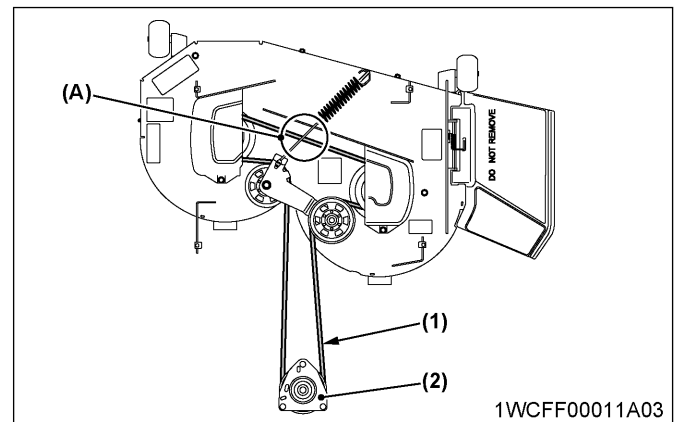
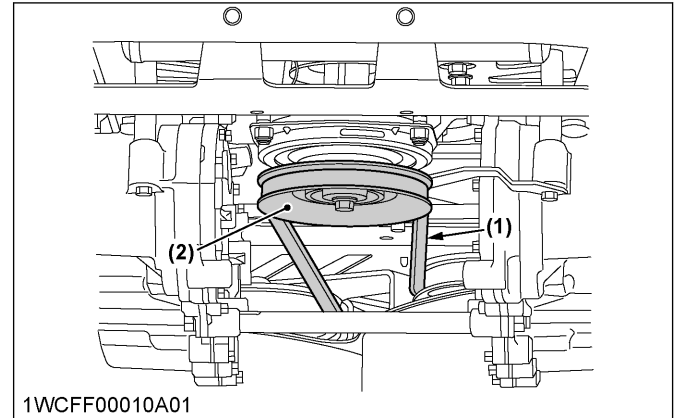

- (1) Mower belt
- (2) Clutch pulley
- (3) Mower belt
- (4) Spring

IMPORTANT :

- Check to see that the mower belt is attached to the pulleys. Make sure that the longer hook of the spring is set to the pulley side.

- After mounting the mower, check the mower level. If necessary, adjust the mower level and anti-scalp rollers.

ADJUSTING THE MOWER

(See OPERATING THE MOWER on page 36 and ADJUSTMENT on page 58.)

DISMOUNTING THE MOWER DECK

- Before dismounting the mower deck, lower the lift links to the lowest cutting height (1.5 in.).

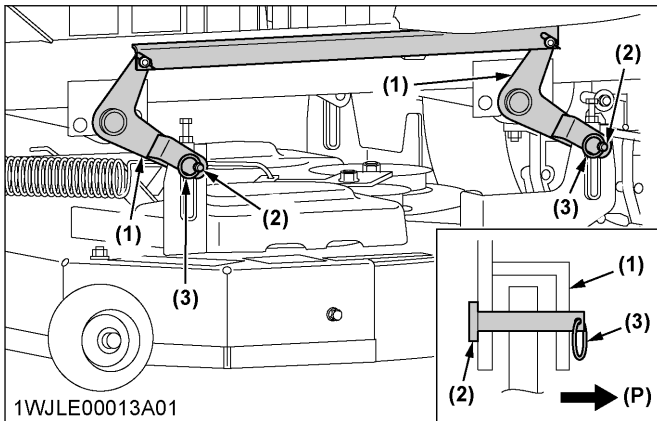

- 1WJLE00013A01
- (1) Lift link
 - (2) Clevis pin
 - (3) Snap ring
- (P) Out side

- Remove the mower belt from the clutch pulley.

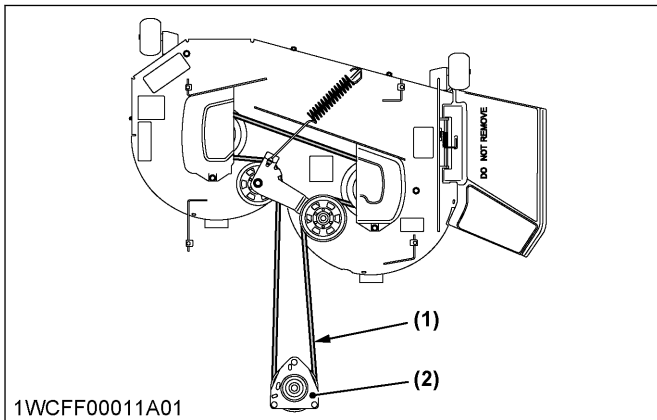

1WCFF00011A01

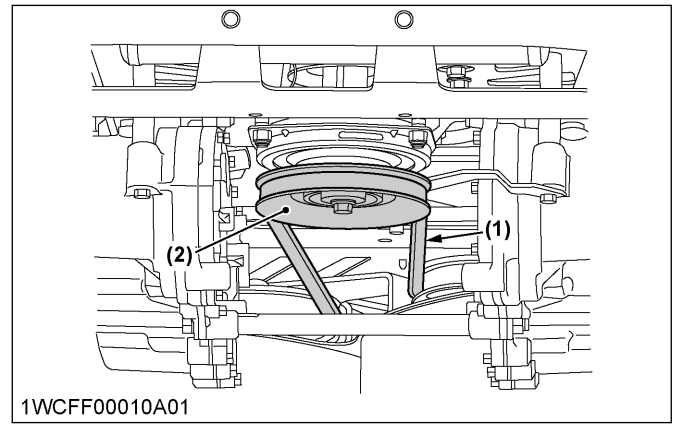

1WCFF00010A01

- (1) Mower belt
- (2) Clutch pulley

- Detach the lift links from the mower deck.
- Raise the mower lift links, then slide the mower deck out from under the machine.

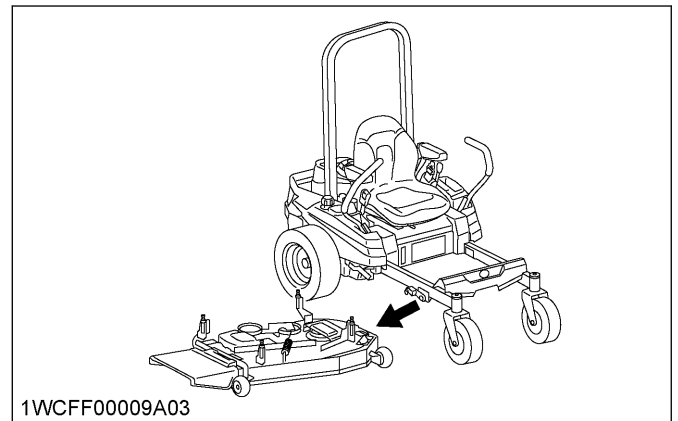

1WCFF00009A03

OPERATING THE ENGINE

WARNING

To avoid serious injury or death:

- Read and understand the safe operation section.
- Read and understand the safety labels located on the machine.
- To avoid the danger of exhaust fume poisoning, do not operate the engine indoors without proper ventilation.
- Never start the engine while standing on the ground. Start the engine only from the operator's seat.

Details regarding safe operation can be found in a different section.

(See SAFE OPERATION on page 5.)

GETTING ON AND OFF THE MACHINE SAFELY

When getting on or off the machine, do not step on the mower deck or mower belt covers.

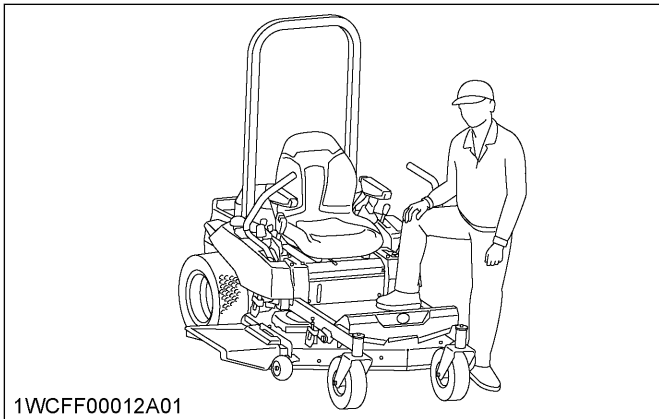

STARTING THE ENGINE

IMPORTANT :

- Do not use starting fluid or ether.
- To protect the battery and the starter, make sure that the starter is not continuously turned for more than 10 seconds at a time.
If the engine does not start, allow a 60 seconds cool down period between starting attempts.
- If the starter does not turn the engine over, shut off the starter immediately. Check the condition of the battery. If the battery condition is satisfactory, do not make further attempts to

start the engine or jump start the engine with another battery. Consult your local Kubota Dealer.

- Do not turn the key switch to the “START” position while the engine is running.
- When the temperature is below 0 °C (32 °F), run the engine at medium speed to warm up the lubricant of the engine and the transmission for at least 10 minutes. If the machine is operated before the lubricant is warm enough, the machine operating life will be shortened.
- Do not operate the machine under full load until it is sufficiently warmed up 2 or 3 minutes for temperature above 0 °C (32 °F).
- When the ambient temperature is less than -15 °C (5 °F), remove the battery from the machine and store it somewhere warm until the next operation.

1. Sit on the operator's seat.
2. Apply the parking brake.

To apply the parking brake:

Place the parking brake lever in the “ENGAGED” position.

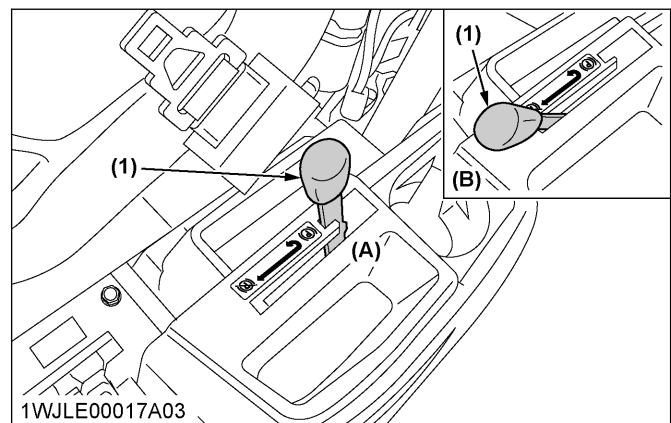

(1) Parking brake lever

(A) (P) “ENGAGED”

(B) (R) “DISENGAGED”

To release the parking brake:

Place the parking brake lever in the “DISENGAGED” position.

- Make sure that the PTO switch is in the "DISENGAGED" (OFF) position.

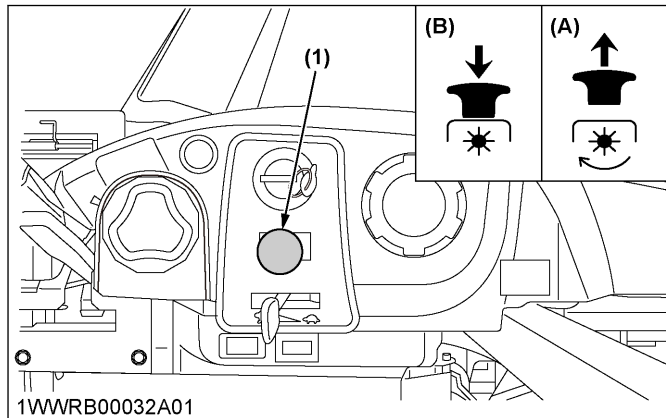

(1) PTO switch
 (A) "ENGAGED" (ON)
 (B) "DISENGAGED" (OFF)

- Place the motion control levers in the "NEUTRAL LOCK" position.

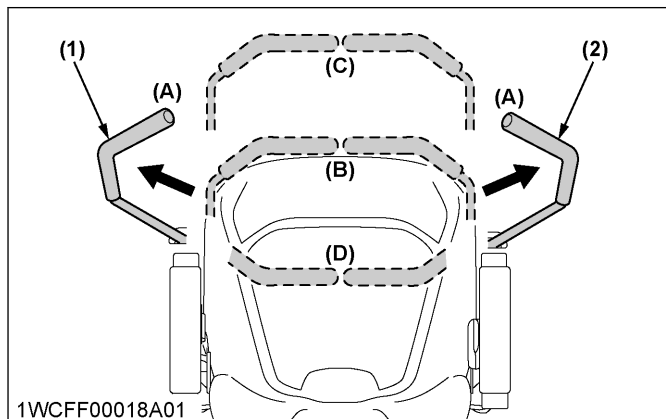

(1) Motion control lever (LH) (A) "NEUTRAL LOCK" position
 (2) Motion control lever (RH) (B) "NEUTRAL" position (held by hands)
 (C) "FORWARD"
 (D) "REARWARD"

- Set the throttle lever as follows.
 Place the throttle lever midway between the "SLOW" and the "FAST" positions.

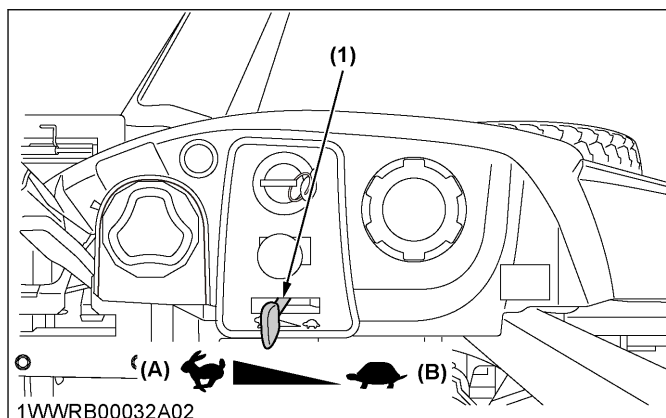

(1) Throttle lever
 (A) "FAST"
 (B) "SLOW"

- Set the choke knob to the "ON" position.

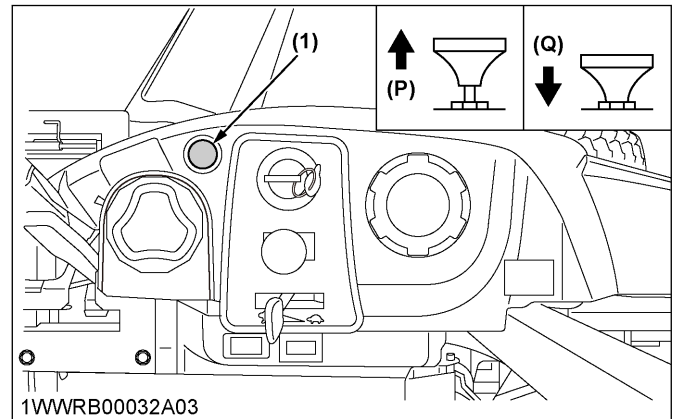

(1) Choke knob
 (P) "PULL" (ON)
 (Q) "PUSH" (OFF)

- Insert the key into the key switch. Turn the key switch to the "START" position and release the key to the "ON" position when the engine starts.
 (See Key switch on page 26.)

IMPORTANT :

- Because of the start interlocks, the engine can not be started except when the PTO switch is disengaged (OFF), the parking brake lever is applied, motion control levers are in "NEUTRAL LOCK" position and the operator is sitting on the seat.

- Place the choke knob to the "OFF" position and warm up the engine by running at medium speed.

1. Choke knob

Pull the choke knob to engage the choke.
 Push in the choke knob to disengage the choke.

When the engine is cold

Always engage the choke to start the engine in cold conditions.

The engine and equipment may be operated during the warm-up period, but it may be necessary to leave the choke partially on until the engine warms up.

When the engine is warm

Always place the choke knob to the "OFF" position when the engine is warm.

2. Throttle lever

Pulling the throttle lever backward decreases the engine speed and pushing it forward increases the engine speed.

3. Key switch

 **OFF**

The position where the key can be inserted into or removed from the key switch. When the key is turned to this position, the engine shuts off.

 **ON**

The engine keeps running.

 **START**

Apply the parking brake and turn the key switch to this position to start the engine.

IMPORTANT :

- Do not stop the engine when the machine is on an incline for a long time. The engine oil may go into the carburetor and the muffler through the valve system.
- Before stopping the engine, place the throttle control lever in the half speed position to help prevent the engine from backfiring.
- If stopping the machine for a long time, turn the fuel valve to the “STOP” (OFF) position.

CHECK DURING OPERATING

IMPORTANT :

Immediately stop the engine if:

- The engine suddenly slows down or accelerates.
- Unusual noises suddenly occur.
- Exhaust fumes suddenly become discolored.

While operating, make the following checks to see that all the parts are functioning normally:

- Fuel gauge on page 26
- Hour meter on page 27

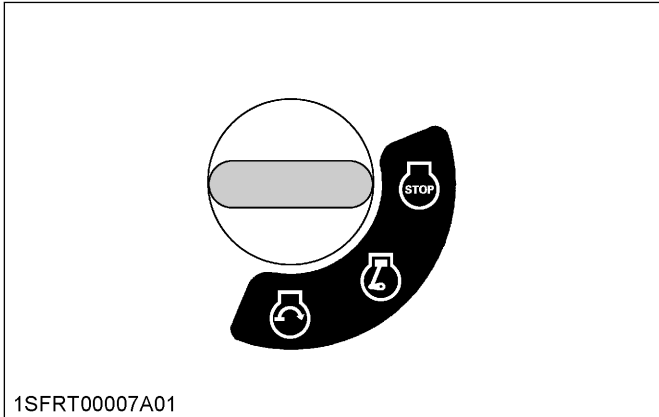

1SFRT00007A01

STOPPING THE ENGINE

1. After setting the engine throttle to “SLOW”, turn the key switch to the “OFF” position.
2. Remove the key.
3. Do not leave the key switch at “ON” (key in the “ON” position), as the battery will discharge when the engine is not running.
4. Apply the parking brake.
5. If stopping the machine for a long time, turn the fuel valve to the “STOP” (OFF) position.

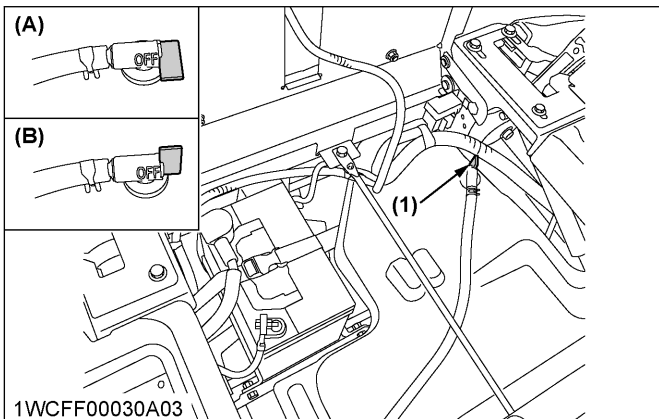

(1) Fuel valve

(A) “STOP” (OFF)
(B) “RUN”

1. Fuel gauge

The fuel gauge indicates the fuel level.

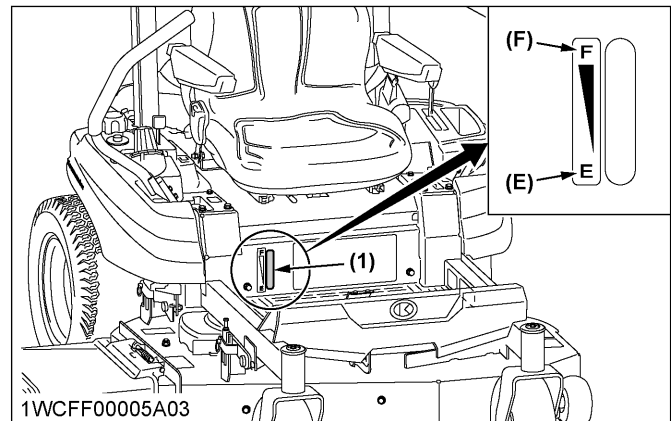

(1) Fuel gauge

(E) “EMPTY”
(F) “FULL”

IMPORTANT :

- Do not fill the tank above the bottom of the filler neck.
- Refuel on a level ground.

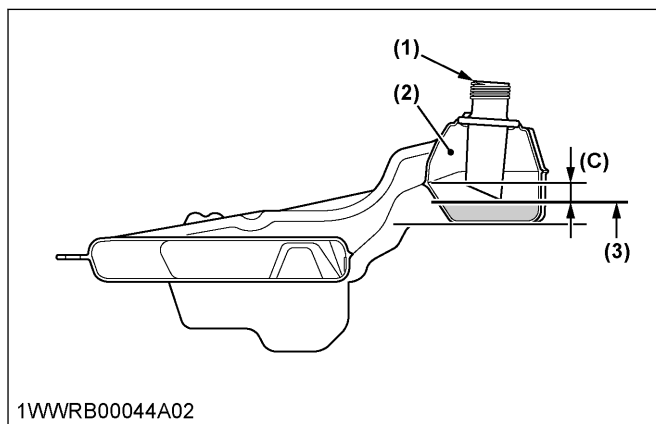

1WWRB00044A02

- (1) Fuel tank filler neck
 (2) Empty space
 (3) Maximum fuel level
- (C) Clearance
 (fuel level is under the filler neck)

2. Hour meter

This meter indicates the number of hours the engine has run.

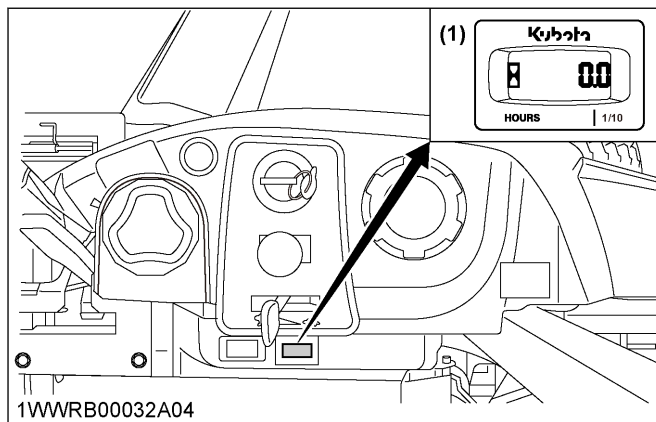

1WWRB00032A04

- (1) Hour meter

COLD WEATHER STARTING

If the ambient temperature is below 0 °C (32 °F) and the engine is very cold, start it in the following manner:

1. Pull the choke knob out ("CHOKE ON" position).
2. Place the throttle lever midway between the "SLOW" and the "FAST" positions.
3. Turn the key switch to the "START" position.
 - a. Operate the starter 5 seconds.
 - b. If the engine does not start, wait 10 seconds.
 - c. Repeat this procedure until the engine starts.
4. When the engine starts, release the key to the "ON" position.
5. Push in the choke knob ("CHOKE OFF" position).

WARMING UP THE ENGINE

⚠ WARNING

To avoid serious injury or death:

- Apply the parking brake during warm-up.

For 5 minutes after the engine start-up, allow the engine to warm up without applying any load. This is to allow oil to reach every part of the engine. If load is applied to the engine without this warm-up period, problems such as seizure, breakage or premature wear may appear.

1. Warm-up and transmission oil in the low temperature range

Hydraulic oil serves as transmission oil. In cold weather conditions, the oil may be cold with increased viscosity. This can cause delayed oil circulation or abnormally low hydraulic pressure for some time after engine start-up. This, in turn, can create problems with the hydraulic system.

To prevent this from happening warm up the engine at about 50% of rated rpm according to the following table.

Ambient temperature	Warm-up time requirement
Higher than 0 °C (32 °F)	Approximately 5 minutes
-10 to 0 °C (14 to 32 °F)	5 to 10 minutes
-20 to -10 °C (-4 to 14 °F)	10 to 15 minutes
Below -20 °C (-4 °F)	More than 15 minutes

IMPORTANT :

- Do not operate unless the engine is well warmed up. If operation is attempted while the engine is still cold, the hydraulic mechanism will not function properly and its service life will be shortened.

JUMP STARTING

⚠ WARNING

To avoid serious injury or death:

- Keep cigarettes, sparks, and flames away from the battery.
- If the machine battery is frozen, do not jump start the engine.
- Do not connect the other end of the negative jumper cable to the negative terminal of the machine battery.

OPERATING THE ENGINE

When jump starting the engine, observe the following instructions to start the engine safely:

1. Bring a helper vehicle with a battery of the same voltage as the disabled machine within easy cable reach.

IMPORTANT :

- **The vehicles must not touch.**

2. Apply the parking brakes of both vehicles and put the motion control levers in the "NEUTRAL LOCK" position. Shut the engine off.
3. Put on safety goggles and rubber gloves.
4. Ensure that vent caps are securely in place (if equipped).
5. Attach the red clamp to the positive (red, (+) or pos.) terminal of the dead battery and clamp the other end of the same cable to the positive (red, (+) or pos.) terminal of the helper battery.
6. Clamp the other cable to the negative (black, (-) or neg.) terminal of the helper battery.
7. Clamp the other end to the engine block or the frame of the disabled machine as far from the dead battery as possible.
8. Start the helper vehicle and let its engine run for a few moments. Start the disabled machine.
9. Disconnect the jumper cables in the exact reverse order of attachment (steps 7, 6 and 5).

Connect the cables in the order listed above.

Disconnect in reverse order after use.

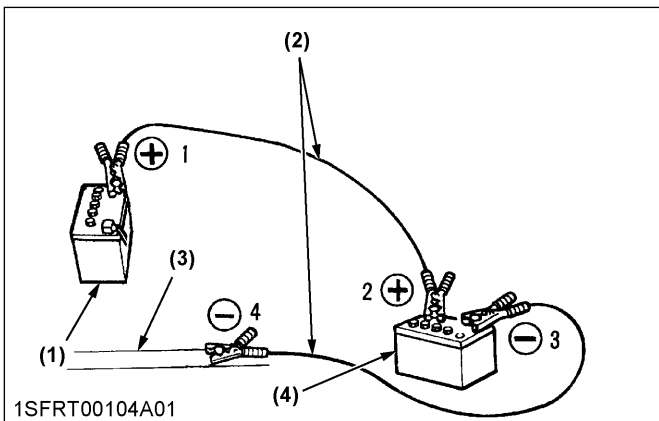

- (1) Dead battery
- (2) Jumper cables
- (3) Engine block or frame
- (4) Helper battery

IMPORTANT :

- **This machine has a 12 volt negative (-) ground starting system.**
 - **Use only same voltage for jump starting.**
 - **Use of a higher voltage source on the machine could result in severe damage to the machine electrical system.**
- Use only a matching voltage source when "jump starting" a low or dead battery.**

OPERATING THE MACHINE



DANGER

To avoid serious injury or death:

- Do not operate the mower without the discharge deflector in the down position.



WARNING

To avoid serious injury or death:

- The machine relies upon the engine driven transmission for speed, direction, and motion control. If the engine is not running, the machine cannot be driven or controlled. If the engine stops when operating on a slope, apply the parking brake immediately to prevent a machine runaway.
- Do not allow anyone other than the driver to ride on the machine.
- Do not drive the machine close to the edges of ditches or banks which may collapse under the weight of the machine, especially when the ground is loose or wet.
- When making a turn, reduce the travel speed and operate the motion control levers carefully.
- To avoid tip-over accidents, operate across slopes, not up and down. Avoid sudden starts and stops on slopes. Slow down and use extra caution when changing direction on a slope. Park the machine on a firm and level surface.
- Watch where you are going at all times. Watch for and avoid obstacles. Be alert at curbs, near trees, and other obstructions and hidden hazards.
- Do not mow near drop-offs, ditches or embankments. The mower could turn over if a wheel is over the edge of a cliff or ditch, or if an edge caves in.
- Do not drive the machine on streets or highways. Watch for traffic when you cross roads or operate near roads.
- Look to the rear before and when backing. Make sure the area immediately behind you is clear of obstructions or holes, and small children. Use extra caution when the machine is equipped with a grass catcher.
- Keep bystanders, especially children, and animals away from the mowing area.
- Clear the work area of objects which might be picked up and thrown by the blades.
- Do not direct the opening of the discharge deflector at bystanders or animals. Ejected

objects may cause injury. Plan your mowing carefully before starting operation.

- Disengage the PTO and sit on the operator's seat before starting the engine.

OPERATING A NEW MACHINE

How a new machine is operated and maintained will determine the operating life of the machine.

A new machine just off the factory production line has been tested, but the various parts are not accustomed to each other, so care should be taken to operate the machine until the various parts become "broken-in". The manner in which the machine is handled during the "breaking-in" period greatly affects the life of your machine.

Therefore, to obtain the maximum performance and the longest operating life of the machine, it is very important to properly break-in your machine. In handling a new machine, the following precautions should be observed.

1. Changing lubricating oil for new machine

The lubricating oil is especially important in the case of a new machine. The various parts are not "broken-in" and are not accustomed to each other. Small metal grit may develop during the operation of the machine and this may wear out or damage the parts. Therefore, care should be taken to change the lubricating oil a little earlier than it would ordinarily be required.

Details regarding normal service intervals can be found in a different section.

(See SERVICE INTERVALS on page 41.)

2. Burnishing PTO clutch

When using the machine for the first time, follow these procedures to maximize mower drive-system life.

1. Keep the throttle lever at 1/2 to 3/4 throttle.

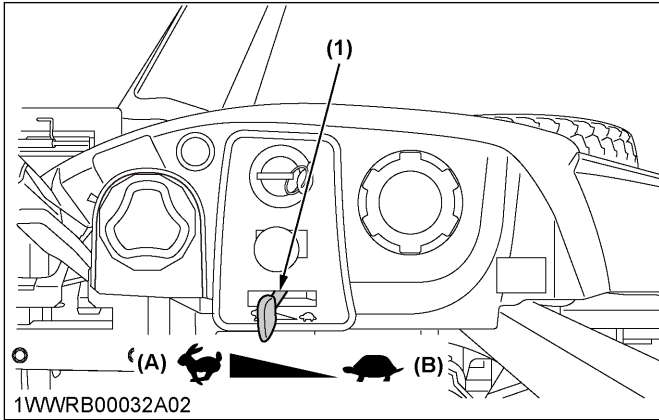

(1) Throttle lever (A) "FAST" (B) "SLOW"

2. Pull the PTO switch to the "ENGAGED" (ON) position for 5 seconds, then push the PTO switch to the "DISENGAGED" (OFF) position for 25 seconds and repeat the cycle 10 times.

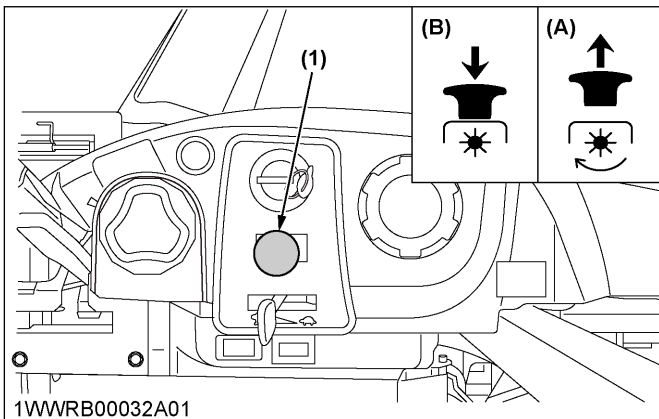

(1) PTO switch (A) "ENGAGED" (ON) (B) "DISENGAGED" (OFF)

STARTING THE MACHINE

WARNING

To avoid serious injury or death:

- Read and understand the safe operation section.
- Read and understand the safety labels located on the machine.
- To avoid the danger of exhaust fume poisoning, do not operate the engine indoors without proper ventilation.
- Never start the engine while standing on the ground. Start the engine only from the operator's seat.

1. Adjust the operator's position and apply the seat belt.
 - Operator's seat on page 30
 - Seat belt on page 31
2. Start the engine. See OPERATING THE ENGINE on page 24.
3. Raise the implement.
 - Mower lift pedal on page 31
4. Accelerate the engine.
 - Throttle lever on page 31
5. Release the parking brake.
 - Parking brake lever on page 31
6. Operate the machine.
 - Motion control lever on page 31
 - Stop position of the motion control lever on page 32
 - Operating position of the motion control lever on page 32

1. Operator's seat

WARNING

To avoid serious injury or death:

- Make adjustments to the seat only while the machine is stopped.
- Make sure that the seat is completely secured after each adjustment.
- Do not allow anyone other than the driver to ride on the machine.

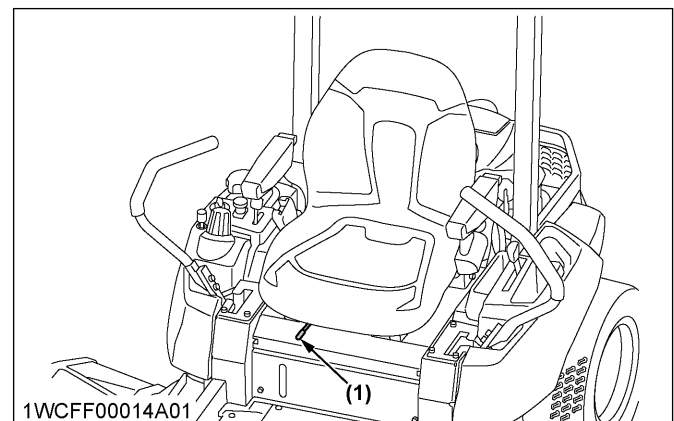

(1) Fore-aft adjusting handle

Fore-aft adjustment

Pull the seat adjusting lever and slide the seat.

Armrest

The armrest may be set at the upright position if desired.

IMPORTANT :

- After adjusting the operator's seat, check and see that the seat is securely locked.

2. Seat belt

WARNING

To avoid serious injury or death:

- Always use the seat belt when the ROPS is installed.
- Do not use the seat belt if a foldable ROPS is down or if there is no ROPS.

Adjust the seat belt for proper fit and connect to the buckle. The seat belt is an auto-locking retractable type.

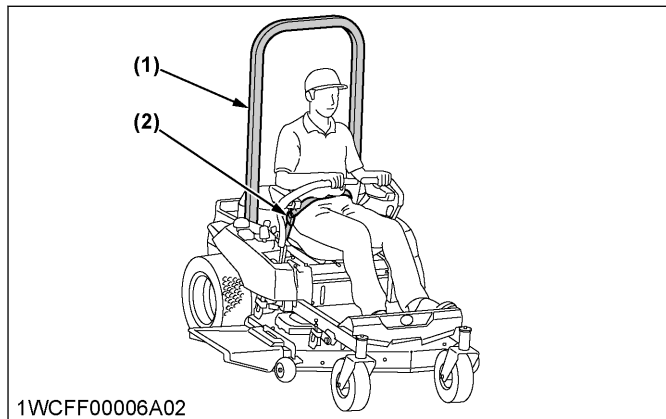

1WCFF00006A02

- (1) ROPS
(2) Seat belt

3. Mower lift pedal

The mower lift pedal is used to raise and lower the mower deck.

1. To set the mower deck at a desired cutting height, refer to the adjusting cutting height procedure. (See OPERATING THE MOWER on page 36)

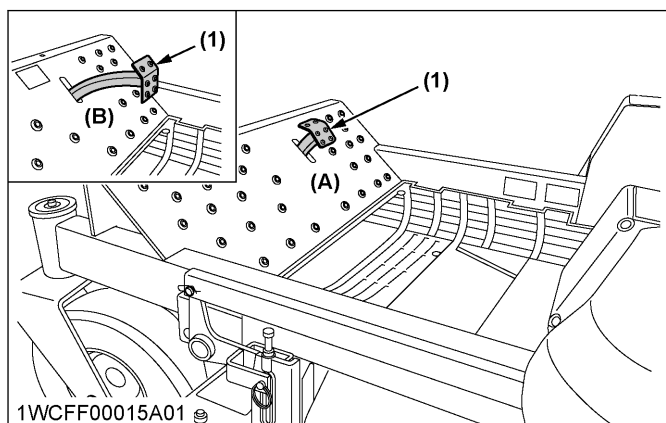

1WCFF00015A01

- (1) Mower lift pedal
(A) "RAISE" position
(B) "LOWER" position

4. Throttle lever

- Move the throttle lever backward to decrease the engine speed.

- Move it forward to increase the engine speed.

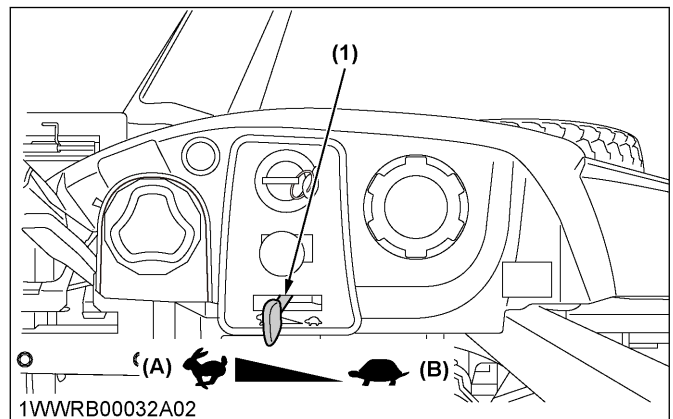

1VWWRB00032A02

- (1) Throttle lever
(A) "INCREASE"
(B) "DECREASE"

5. Parking brake lever

To apply the parking brake:

Place the parking brake lever in the "ENGAGED" position.

To release the parking brake:

Place the parking brake lever in the "DISENGAGED" position.

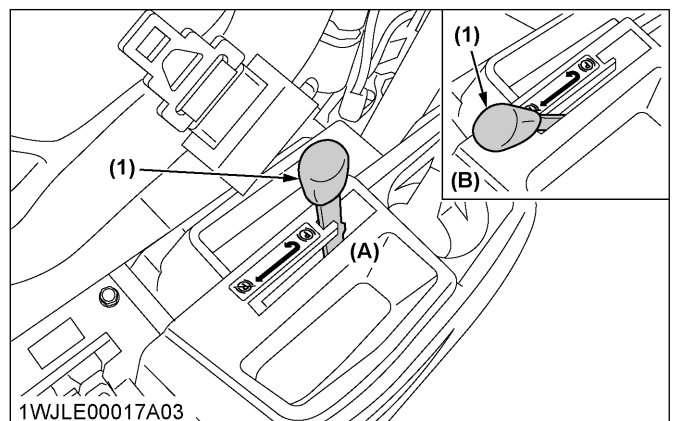

1WJLE00017A03

- (1) Parking brake lever
(A) (P) "ENGAGED"
(B) (R) "DISENGAGED"

6. Motion control lever

WARNING

To avoid serious injury or death:

- Understand how to use the motion control levers and practice in an unrestricted area at slightly more than idle speed without the mower engaged until becoming proficient in the operation of the machine.
- Do not move motion control levers from the "FORWARD" to "REARWARD" or from the "REARWARD" to "FORWARD" position rapidly. Sudden direction changes could cause the loss of control or damage to the machine or property.

- Do not make sharp turns at high speed. Fast and sharp turns could cause the loss of control.
- Motion control levers must be in the “NEUTRAL LOCK” position to safely enter and exit the operator’s seat or to carry out maintenance and safety checks.
- This machine can make sharp turns. Always make sure your intended path is clear of obstructions or people.

6.1 Stop position of the motion control lever

Neutral lock position

Forward and rearward movements of the motion control levers are locked when these levers are in the “NEUTRAL LOCK” position (the engine can only be started with levers in this position).

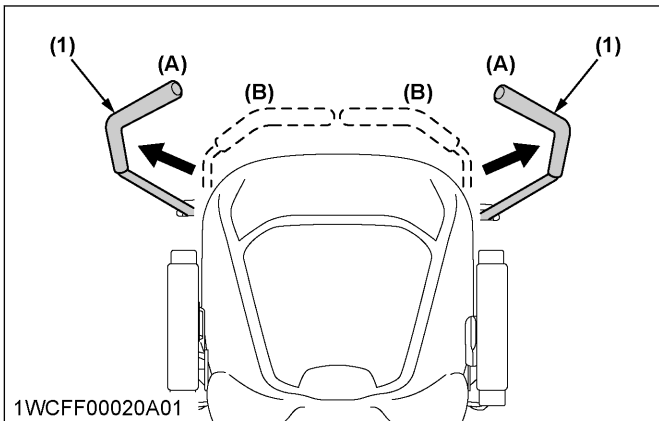

(1) Motion control levers (A) “NEUTRAL LOCK” position (B) “NEUTRAL” position (held by hand)

6.2 Operating position of the motion control lever

Machine speed and steering is controlled by the motion control levers, when the engine is running and the parking brake is released.

⚠ WARNING
To avoid serious injury or death:

- No control is provided by the motion control levers when the engine is off.

Neutral position

Grasp the motion control levers and move them inward from the “NEUTRAL LOCK” position so that the machine is in “NEUTRAL” (the engine cannot be restarted).

Forward and rearward motion:

1. Move the throttle lever to the “FAST” position.
2. Release the parking brake.

3. Move both motion control levers from the “NEUTRAL LOCK” position inward to the “NEUTRAL” position.
4. To move your machine, see the following figures.

To stop:

Move and hold both motion control levers to the “NEUTRAL” position until the machine comes to a stop.

Forward:

For forward travel in a straight line, push both motion control levers forward equally and slowly.

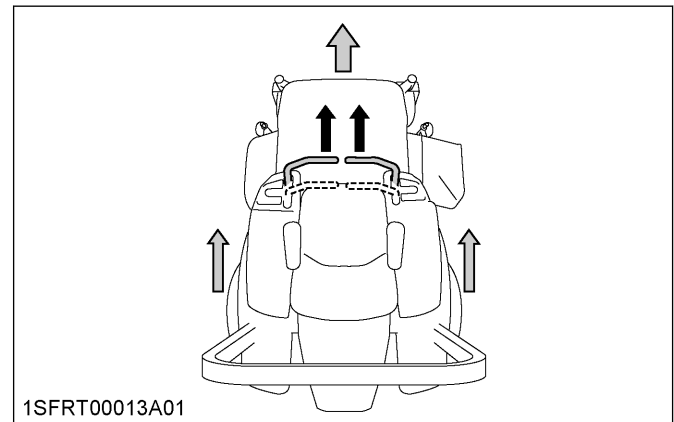

Rearward:

For rearward travel in a straight line, pull both motion control levers past center rearward equally and slowly.

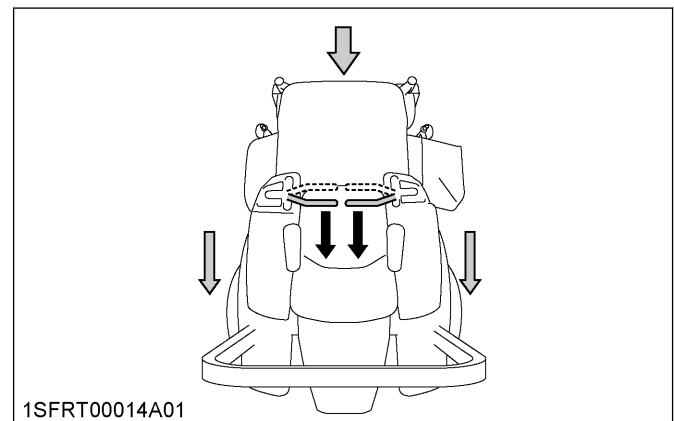

General left turn:

For forward travel to the left, push the right motion control lever further forward than the left motion control lever.

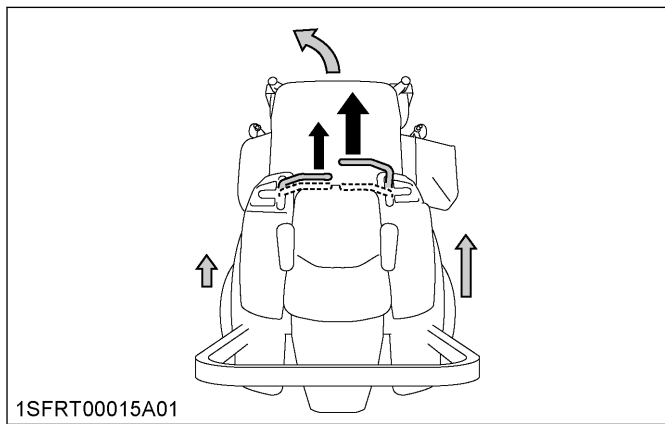
**General right turn:**

For forward travel to the right, push the left motion control lever further forward than the right motion control lever.

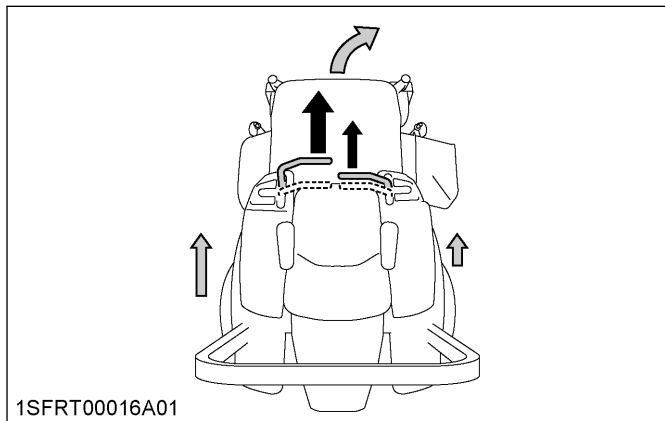
**Sharp (zero) left turn:**

Push the right motion control lever forward and pull the left motion control lever rearward at the same time.

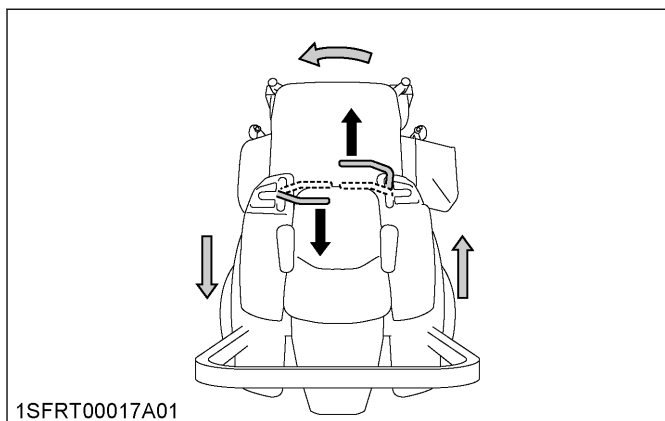
**Sharp (zero) right turn:**

Push the left motion control lever forward and pull the right motion control lever rearward at the same time.

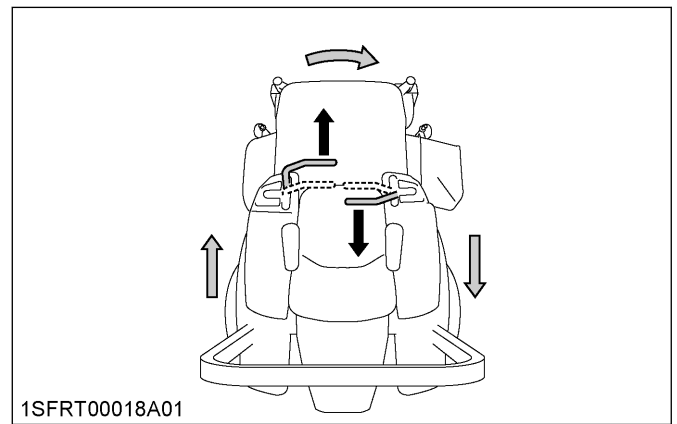
**6.3 Adjustment of the motion control lever****! WARNING**

To avoid serious injury or death:

- The motion control lever adjustment is important to ensure the machine operates properly.

NOTE :

- The motion control levers are adjustable. (If adjustment is required, see ADJUSTMENT on page 58.) We recommend that you contact your local Kubota Dealer.

STOPPING THE MACHINE**! WARNING**

To avoid serious injury or death:

- Park the machine on level ground. If necessary to park on an incline, stop the machine, apply the parking brake, and then stop the engine.
- If you stop the engine on an incline without applying the parking brake, the machine could move and run away.

IMPORTANT :

- The parking brake lever is for parking use only. If the parking brake is applied when the motion control levers are not in the "NEUTRAL LOCK" position, the engine will stop. This feature is to prevent brake and transmission damage during operation.
- If on a slope and the engine quits, use the parking brake as the emergency brake and immediately stop the unit.
- Do not stop the engine when the machine is on an incline for a long time. The engine oil may go

into the carburetor and the muffler through the valve system.

- Before stopping the engine, place the throttle control lever in the half speed position to help prevent the engine from backfiring.
1. Move both motion control levers to the “NEUTRAL” position to stop the machine.
 2. Move both motion control levers to the “NEUTRAL LOCK” position.
 3. Apply the parking brake.
 4. Move the throttle lever to the half speed position and push the PTO switch to the “DISENGAGE” (OFF) position.
 5. Lower all implements to the ground.
 6. Turn off the engine and remove the key.

PARKING THE MACHINE

WARNING

To avoid serious injury or death:

Before leaving the operator's position:

- Apply the parking brake.
- Lower all implements to the ground.
- Shut off the engine.
- Remove the key.
- Place the motion control levers in the “NEUTRAL LOCK” position.

See Parking brake lever on page 31 for how to operate the parking brake lever.

If necessary to park on an incline, chock the wheels on the downhill side to prevent accidental rolling of the machine.

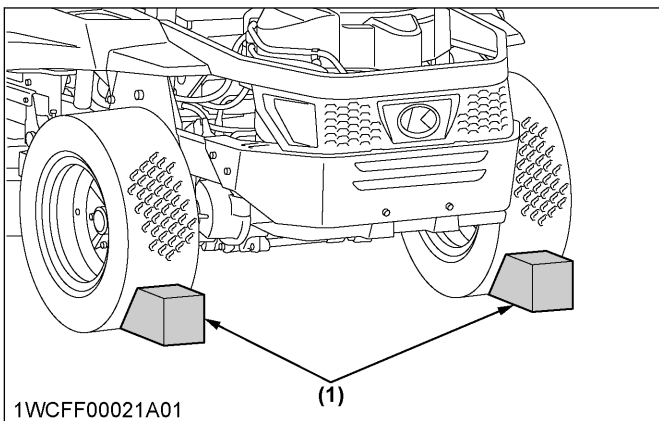

(1) Chock

TRANSPORTING THE MACHINE

IMPORTANT :

- To transport the machine on a trailer:
 - Turn the carburetor fuel valve to the “OFF” position.

- Fasten the machine to the trailer.
- Do not attempt to tow this machine, or damage to the transmission may result.
 - When transporting the machine over a long distance:
 - Set the cutting height at 108 mm (4.25 in.) position.

1. Hydrostatic transaxle bypass rods

WARNING

To avoid serious injury or death:

- Do not touch the muffler or exhaust pipes while they are hot. Severe burns could result.

IMPORTANT :

- Do not push the machine without pulling the bypass rods, or transmission damage may occur.
- Never pull the rods with the engine running.

1. While facing the machine from the rear, pull the left side HST bypass rod out of the “OPERATING” position hole and place it into the “BYPASS” position hole.

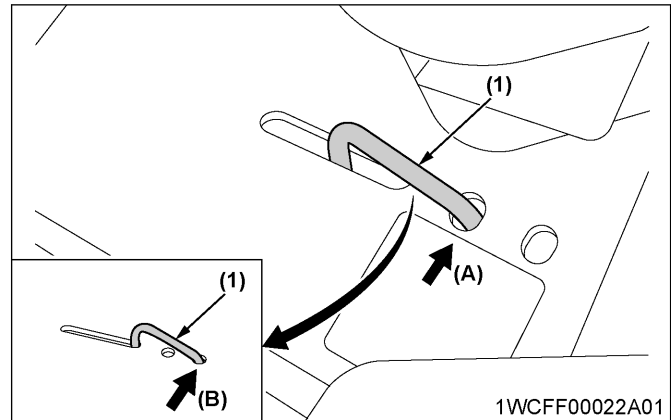

(1) Left side HST bypass rod

(A) “OPERATING” position

(B) “BYPASS” position

- Pull the right side HST bypass rod out of the "OPERATING" position hole and pull to the "BYPASS" position. Continue to hold the right side HST bypass rod in the "BYPASS" position in order to move the machine.

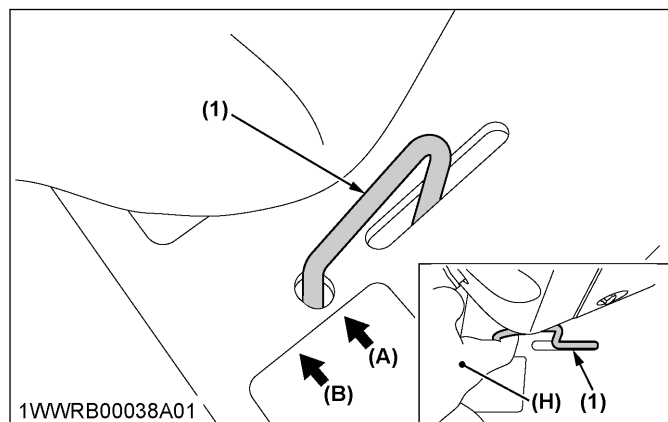

- (1) Right side HST bypass rod (A) "OPERATING" position
 (B) "BYPASS" position
 (H) "HOLD"

- After moving, place both the right side and left side HST bypass rod back into the "OPERATING" position hole.

ACCESSORY

1. Accessory electrical outlet

You may use the accessory electrical outlet to connect an auxiliary light or other devices.



WARNING

To avoid serious injury or death:

- Do not use when the accessory electrical outlet is wet.

IMPORTANT :

- Do not connect a light or other device that draws more than 120 watts to accessory electrical outlet. The battery may discharge very rapidly or the accessory electrical outlet may fail.

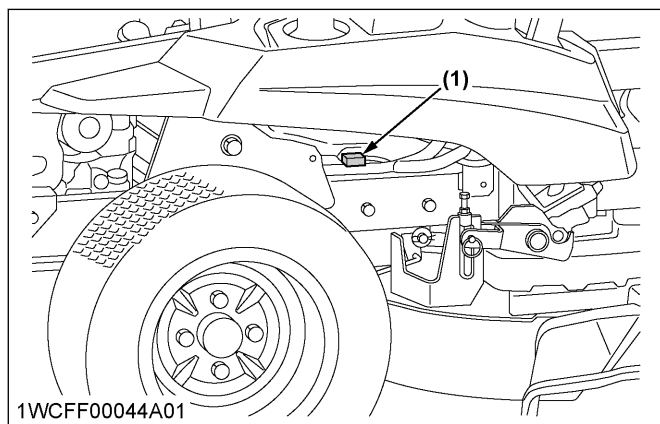

- (1) Accessory electrical outlet (12 V, maximum 10 A)

OPERATING THE MOWER

MOWING TIPS

WARNING

To avoid serious injury or death:

- Clear the work area of objects which might be picked up and thrown by the blades.
- Keep bystanders and animals away from the mowing area.

1. When using the mower for the first time, choose a smooth level area and cut in straight and slightly overlapping strips.
2. The size and type of the area to be mowed will determine the proper mowing pattern. Take into account obstructions, such as trees, fences and buildings.

To keep grass clippings off fences, sidewalks and so on, it is advisable to go over the outside of the area to be mowed several times in a clockwise direction.

To mow the area remaining, work in a counterclockwise direction so that the clippings are dispersed onto the previously cut area.

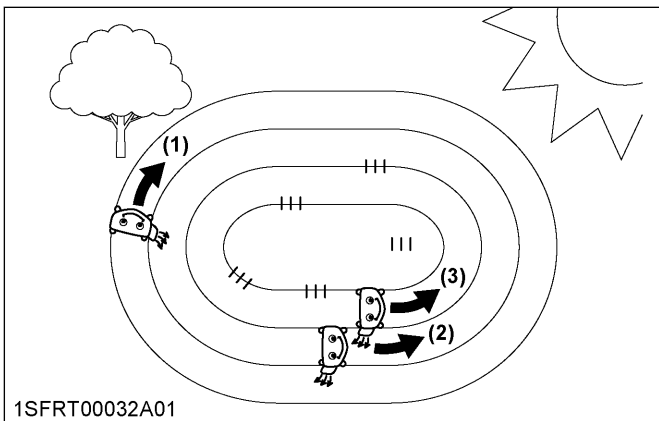

3. Always keep the left side of the mower toward trees, posts or other obstacles on the first trip around the obstacle.
4. Most lawns should be mowed to keep the grass approximately 50 to 80 mm (2 to 3 in.) high. Best results are obtained by cutting often and not too short. To keep a green lawn, never mow more than 1/3 of the height of the grass or a maximum of 25 mm (1 in.) in 1 mowing.
For extremely tall grass, set the cutting height at maximum cutting height for the first mowing, then reset to the desired height and mow again. Allow the grass to grow to 80 mm (3 in.), then cut off only the top inch.

5. Clippings may be left on the lawn unless they form clumps or rows.

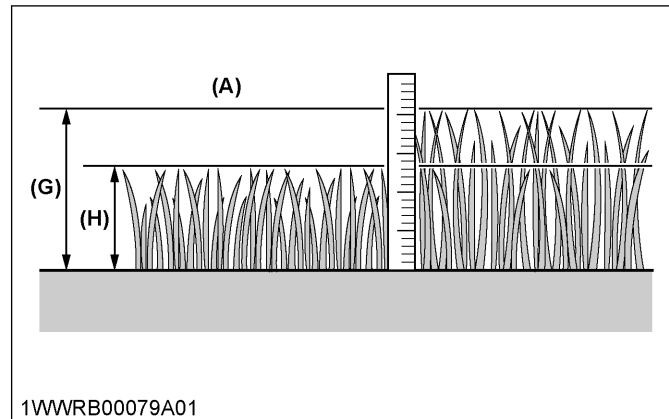

(A) $H/G > 2/3$

(G) Before mowing

(H) Best cut grass height: 50 to 80 mm (2 to 3 in.)

6. For best appearance, grass must be cut in the afternoon or evening when it is free of moisture.

ADJUSTING THE CUTTING HEIGHT

1. Before adjusting the cutting height, check that all tire pressures are correct. If necessary, adjust to the correct tire pressure.

- To set the cutting height, push and hold the mower lift pedal in the "RAISE" position. Then adjust the cutting height control dial to the desired height.

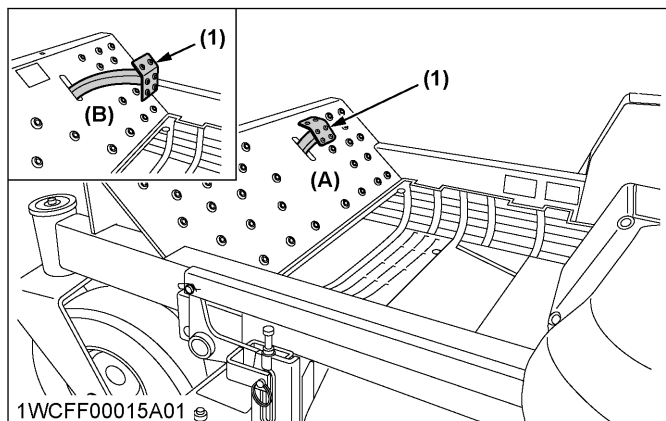

(1) Mower lift pedal
 (A) "RAISE" position
 (B) "LOWER" position

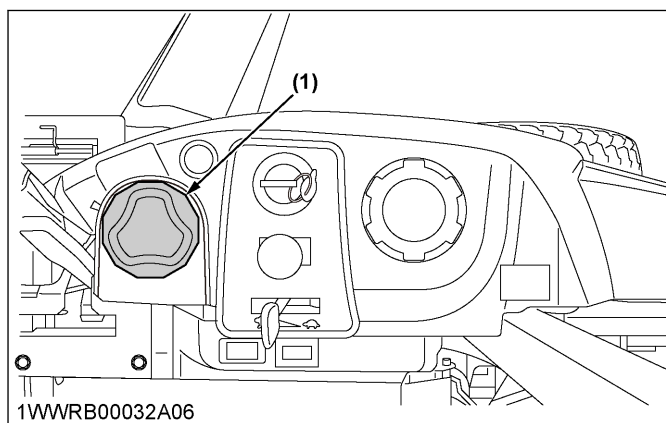

(1) Cutting height control dial

- Use higher settings for mowing in a rough area or when mowing tall grass. Lower settings should be used only for smooth lawns where short grass is desired.
- Lower the mower deck by gently lowering the mower lift pedal. This lowers the mower deck to the "OPERATING" position.
- Adjust the anti-scalp rollers' height as follows for normal operating condition.

IMPORTANT :

- Never allow the rollers to contact the ground continuously as premature roller wear may develop if set incorrectly.
- Anti-scalp rollers must maintain a minimum clearance of 6 mm (0.25 in.) to the ground.

Bolt setting

ANTI-SCALP ROLLER SETTING

Adjust the anti-scalp rollers' height as recommended below.



CUTTING HEIGHT INCH

- 1.5"-1.75"
- 2.0"-2.25"
- 2.5"-2.75"
- 3.0"-4.5"

CLEARANCE

Never allow roller to contact the ground continuously as premature roller wear may develop if set incorrectly.

1WJLE00021A01enUS

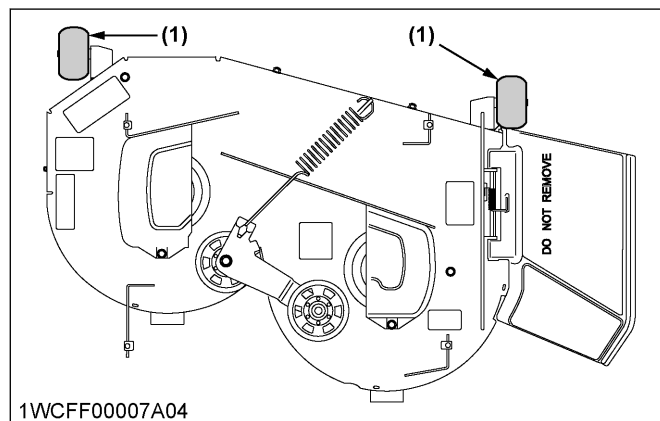

(1) Anti-scalp roller (front, bolt shift type)

OPERATING THE MOWER

⚠ DANGER

To avoid serious injury or death:

- Do not operate the mower without the discharge deflector being in place properly.

⚠ WARNING

To avoid serious injury or death:

- Clear the work area of objects which might be picked up and thrown.
- Do not direct the opening of the discharge deflector at bystanders, especially children, or animals. Discharged objects may cause injury. Plan your mowing carefully before starting the operation.
- Keep bystanders and animals away from the mowing area.

- Disengage the PTO clutch of the mower before attempting to start the engine.

1. PTO switch

1. To engage the PTO, pull the PTO switch to the "ENGAGED" (ON) position.
2. To disengage the PTO, push the PTO switch to the "DISENGAGED" (OFF) position.

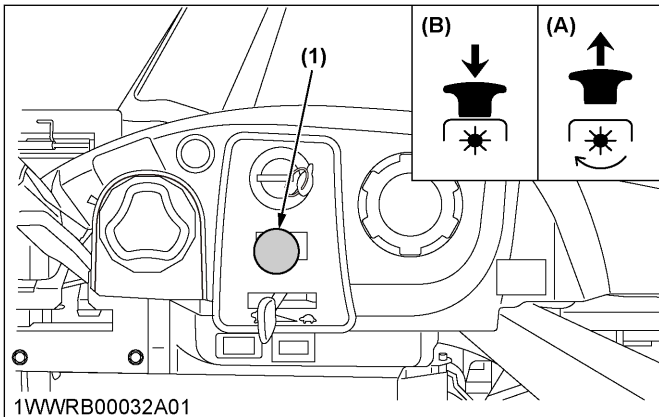

(1) PTO switch

(A) "ENGAGED" (ON)

(B) "DISENGAGED" (OFF)

NOTE :

- If you get off the seat while the PTO is running, the engine will stop automatically (operator presence control).
- Before starting the engine, push the PTO switch to the "DISENGAGED" (OFF) position. If it is at the "ENGAGED" (ON) position, the engine will not start.
- These interlock features are built-in.

2. Starting the machine

WARNING

To avoid serious injury or death:

- Engine components can get extremely hot from operation. To prevent severe burns, do not touch these areas while the engine is running, or immediately after it is turned off.
- Never operate the engine without heat shields or guards.

1. Sit on the operator's seat.
Put on the seat belt. Make sure that the parking brake is engaged.
2. Start the engine.
3. Engage the PTO switch.

IMPORTANT :

Follow these procedures to maximize mower drive-system life.

- Keep the throttle lever at half throttle when engaging the PTO.
- The mower deck position should be set to the highest cutting position when engaging the PTO.

4. Disengage the parking brake.
5. Speed up the engine by moving the throttle lever forward.
6. Push or pull the motion control levers to move forward or rearward.

IMPORTANT :

- Never attempt to move the machine with the parking brake "ENGAGED" (ON).

NOTE :

- Keep the engine running at full throttle for best results. Control the travel speed with the motion control levers.
- During heavy duty use, operate the machine at a slower ground speed or go over the area twice.
- Keep the mower deck in the raised position when the mower is disengaged.
- The mower will not cut cleanly if the ground speed is too high or if the blade speed drops due to an overload.
- If debris builds up on the grass screen or other cooling air intake areas, stop the engine and clean them. Operating the engine with blocked or dirty air intake and cooling areas causes damage due to overheating.

TIRES AND WHEELS

TIRES

⚠ WARNING

To avoid serious injury or death:

- Do not attempt to mount a tire. This should be done by a qualified person with the proper equipment.
- Always maintain the correct tire pressure. Do not inflate tires above the recommended pressure shown in the Operator's Manual.
- The inflation pressure in the front tires rises quickly when using compressed air.
- Never operate the machine with a loose rim, wheel, or axle.
- Whenever bolts and nuts are loosened, retighten to the specified torque.
- Check all the bolts and nuts frequently and keep them tightened.

1. Inflation pressure

Even though the inflation pressure is factory-set to the prescribed level, it naturally drops slowly in the course of time. Therefore, check it everyday and inflate as necessary.

	Tire sizes	Recommended inflation pressure
Front	11 x 4 - 5, 4PR smooth	170 kPa (1.7 kgf/cm ² , 25 psi)
Rear	18 x 7.5 - 10, 4PR turf	83 kPa (0.9 kgf/cm ² , 12 psi)

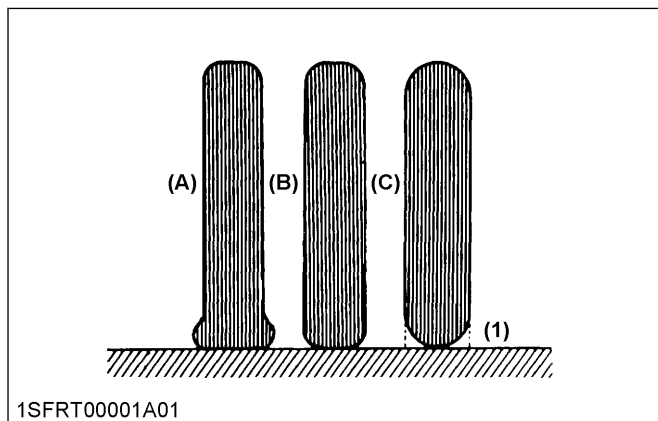

(1) Ground
 (A) "INSUFFICIENT"
 (B) "NORMAL"
 (C) "EXCESSIVE"

WHEELS

1. Installing the rear wheels

IMPORTANT :

- When refitting a wheel, tighten the wheel bolt to the following torques then recheck after traveling 200 m (200 yards), changing directions several times.
- When using wheels with beveled or tapered holes, use tapered wheel nuts.

Rear

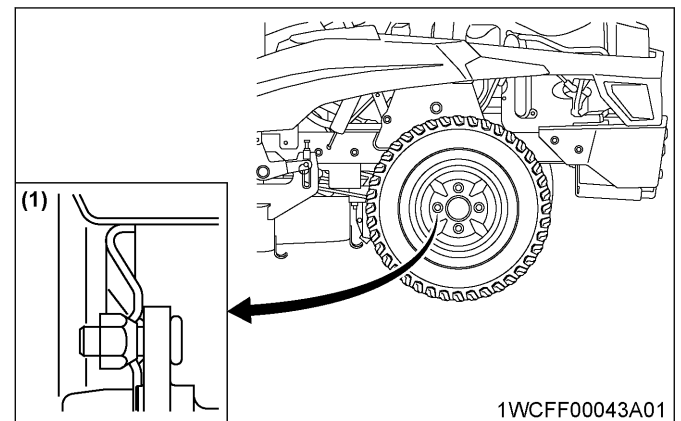

(1) 108.5 to 130.2 N·m
 (80 to 96 lbf·ft)
 (11.1 to 13.3 kgf·m)

2. Removing the front caster wheels

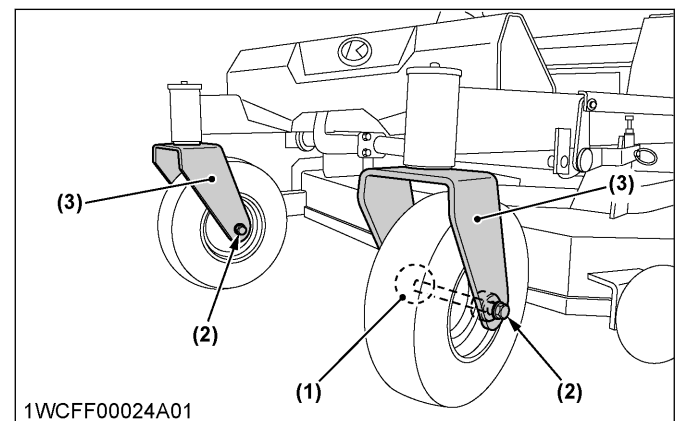

(1) Nut
 (2) Wheel bolt
 (3) Yoke

1. Park the machine on a firm and level surface.
2. Stop the engine and apply parking brake.
3. Lift the front of machine with a safe lifting device.

4. Remove the nut and the wheel bolt.
5. Remove the wheel from assembly yoke.

3. Installing the front caster wheels

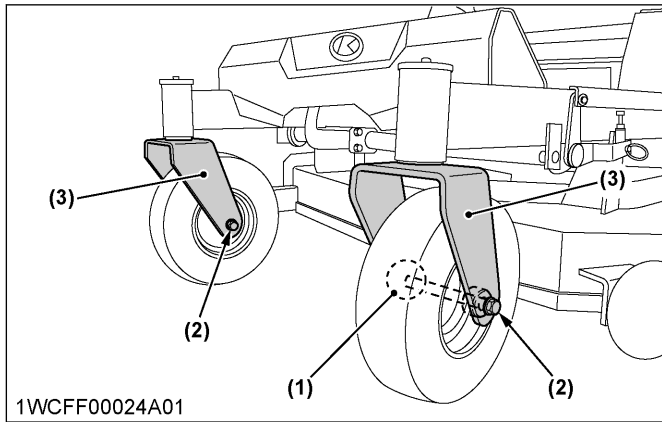

- (1) Nut
- (2) Wheel bolt
- (3) Yoke

1. Install the replacement wheel.
2. Install the wheel bolt and the nut.
3. Tighten the nut.

Tightening torque	48 to 56 N·m (36 to 41 lbf·ft) (4.9 to 5.7 kgf·m)
-------------------	---

4. Lower the machine.

IMPORTANT :

- **Make sure that a washer is set on wheel bolt side.**

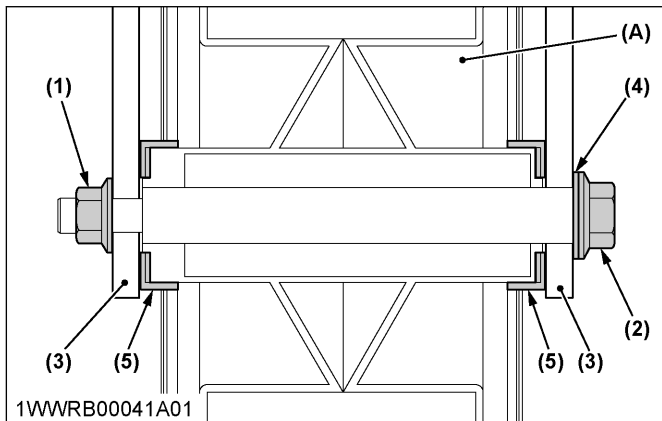

- (1) Nut
- (2) Wheel bolt
- (3) Yoke
- (4) Washer
- (5) Cap with felt

(A) Front wheel

MAINTENANCE

SERVICE INTERVALS

The following servicing tasks should be carried out on the machine at the stated running-time intervals.

Items		Indication hour meter (hr)												Ref. page	
		50	100	150	200	250	300	350	400	450	500	550	600		After since
Engine oil	Change		•		•		•		•		•		•	every 100 hr or every 1 year	48, 55
Engine start system	Check	•	•	•	•	•	•	•	•	•	•	•	•	every 50 hr	46
OPC system	Check	•	•	•	•	•	•	•	•	•	•	•	•	every 50 hr	47
Muffler and spark arrester (if equipped)	Check	•	•	•	•	•	•	•	•	•	•	•	•	every 50 hr or every 1 year	47, 55
Air cleaner paper element	Clean		•				•				•			every 100 hr	49
	Replace				•				•				•	every 200 hr	53
Fuel filter	Check		•		•		•		•		•		•	every 100 hr	50
Battery condition	Check		•		•		•		•		•		•	every 100 hr or every 1 year	51, 54
Throttle cable	Adjust		•		•		•		•		•		•	every 100 hr	52
Choke cable	Adjust		•		•		•		•		•		•	every 100 hr	52
Spark plug	Check		•		•		•		•		•		•	every 100 hr	50
Engine cooling system	Clean		•		•		•		•		•		•	every 100 hr	49
Engine oil filter	Replace				•				•				•	every 200 hr	52
Combustion chamber	Clean						•						•	every 300 hr	54
Valve seats and clearance	Check						•						•	every 300 hr	54
Fuel line	Check													every 1 year	54
	Replace													every 4 years	55
Fuse	Replace													Service as required	55
Blade	Replace														56
Mower belt	Replace														57
Electric clutch	Adjust														57

*1 This maintenance should be done daily or more often in dusty conditions than in normal conditions.

*2 Consult your local Kubota Dealer for this service.

*3 Replace if any deterioration (crack, hardening, scar, or deformation) or damage occurred.

IMPORTANT :

- **Maintenance instructions related to gasoline engine emissions:**
 - **Non-warranty maintenance, repairs, or replacement of the emission control devices and systems should be performed by a qualified repair establishment or an individual who has the experience and equipment to perform such work.
See the Emissions Warranty Statement.**
 - **To ensure the best quality and reliability, use new Kubota genuine parts or their equivalents for repairs and replacement, whenever you have maintenance done.**

LUBRICANTS AND FUEL

Locations	Capacities	Lubricants
	Z232KW	
Fuel	13.6 L (3.6 U.S. gals.)	<ul style="list-style-type: none"> Automobile unleaded or regular gasoline Unleaded gasoline 87 octane or higher
Engine crankcase	2.1 L (2.2 U.S.qts.)*1	<ul style="list-style-type: none"> Engine oil: API service Classification SF, SG, SH, SJ or SL Above 20 °C (68 °F)...SAE40 Between 10 °C (50 °F) to 30 °C (86 °F)...SAE30 Between -10 °C (-4 °F) to 40 °C (104 °F)...SAE10W-40 Between -10 °C (-4 °F) to 30 °C (86 °F)...SAE10W-30

*1 Oil amount when the oil level is at the upper level of the oil level gauge.

- Fuel:**
- Clean, fresh, unleaded gasoline.
 - A minimum of 87 octane/87AKI (90 RON).
 - Gasoline with up to 10 % ethanol (ethyl or grain alcohol) or up to 15 % methyl tertiary butyl ether (MTBE) by volume is acceptable.
 - Do not use unapproved gasoline, such as E85. Do not mix oil in gasoline or modify the engine to run on alternate fuels. This will damage the engine components and void the engine warranty.
 - This engine is certified to operate on gasoline. The emissions control system for this engine is engine modifications (EM).
 - High altitude:
This engine may require a high altitude carburetor kit to ensure correct engine operation at altitudes above 3300 ft. (1006 meters). Operation without this kit will cause decreased performance, increased fuel consumption, and increased emissions.
This engine should be operated in its original configuration below 3300 ft. (1006 meters) as damage may occur if a high altitude carburetor kit is installed and operated below 3300 ft. (1006 meters).
 - The indicated capacity of fuel is the manufacturer's estimate.

- Engine oil:**
- Oil used in the engine should have an American Petroleum Institute (API) service classification and proper SAE Engine oil according to the ambient temperatures as shown in the previous table.
 - The indicated capacity of oil is the manufacturer's estimate.

PERIODIC SERVICE

RAISING AND LOWERING THE OPERATOR'S SEAT

Raising

⚠ WARNING
 To avoid serious injury or death:

- Fully raise the operator's seat to the resting position.
 Do not keep the seat halfway.

1. Pull the latch lever on the seat panel rearward.

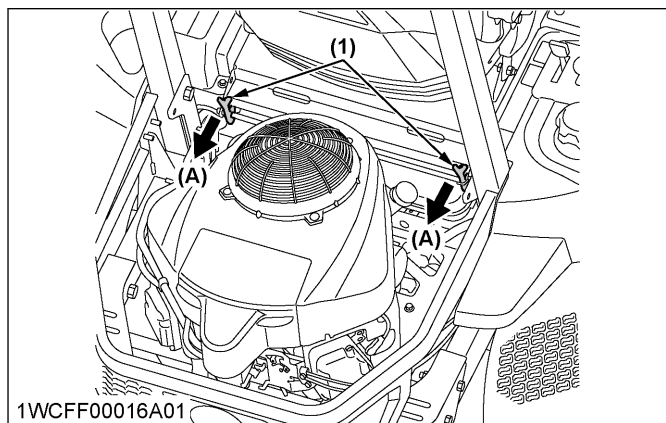

(1) Latch lever (A) "PULL"

2. Raise the operator's seat to the resting position.

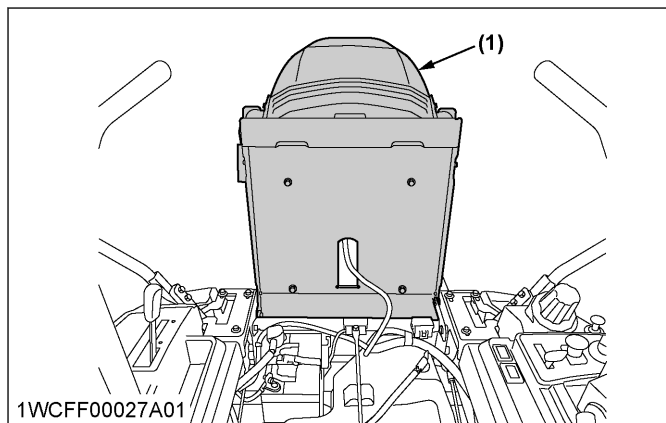

(1) Operator's seat

Lowering

⚠ WARNING
 To avoid serious injury or death:

- Do not drop the seat when lowering it.
- Watch your hands. Do not place your hands under the seat when lowering it.

1. Lower the seat slowly to lock.

DAILY CHECK

To prevent trouble from occurring, it is important to know the condition of the machine. Check it before starting.

⚠ WARNING
 To avoid serious injury or death:

- Check and service the machine on a level surface with the engine shut off, the key removed and the parking brake securely set or the rear wheels chocked.

	Check item	Ref. page
Walking around the machine	Damage to machine body, tightness of all bolts, nuts, pins, and so on.	—
	Fuel and oil leak	48 50
	Tire pressure, wear and damage	39 45
	Engine oil level	44
	Fuel level	44
	Air intake screen	45
	Air cleaner	49
	Machine body cleaning	—
	Clean area around the muffler and engine controls.	47
	Clean debris from all of drive pulleys.	—
Mower	Check all hardware.	—
	Make sure all pins are in place.	22
	Mower deck cleaning	56
	Clean debris from all of drive pulleys.	—
	Make sure blade bolts are tight.	56
	Blades and belt wear or damage	56
While sitting in the operator's seat	Motion control lever	58
	Parking brake	31
	Other movable parts	46

(Continued)

	Check item	Ref. page
Starting the engine	Color of the exhaust fumes	26
	Check for abnormal noise and vibration.	26
	Engine start system/OPC system. If either of these do not operate properly, contact your local Kubota Dealer immediately.	46 47
Others	Check the areas where previous trouble was experienced.	—

1. Checking the engine oil level

WARNING

To avoid serious injury or death:

- Always stop the engine and remove the key before checking the oil.

1. Check the engine oil before starting and 5 minutes or more after the engine has stopped.
2. Wipe the dipstick area clean.
3. To check the oil level, remove the dipstick, wipe it clean, replace it but do not tighten (Ref to Kawasaki manual), and draw it out again. Check to see that the oil level is between the 2 notches.
4. Add new oil to the prescribed level at the oil port if necessary.

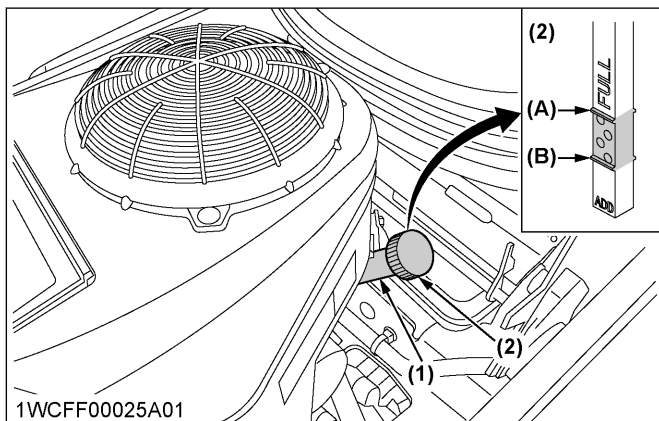

(1) Engine oil port
(2) Oil level dipstick

(A) "UPPER LEVEL"
(B) "LOWER LEVEL"

IMPORTANT :

- When using a different brand or viscosity oil from the previous one, remove all of the old oil and the oil filter. Never mix 2 different types of oil.
- Use the proper SAE engine oil according to the ambient temperature.
(See LUBRICANTS AND FUEL on page 42.)

2. Checking the amount of fuel and refueling

WARNING

To avoid serious injury or death:

- Handle the fuel carefully. If the engine is running, do not fill the fuel tank. If the engine is hot, let the engine cool down several minutes before adding fuel.
- Do not smoke while filling the fuel tank or servicing the fuel system. Fill the fuel tank only to the bottom of the filler neck. Do not fill until completely full. The empty space in the tank allows gasoline to expand when it heats up.
- Never remove the fuel tank cap or add fuel when the fuel tank is hot.

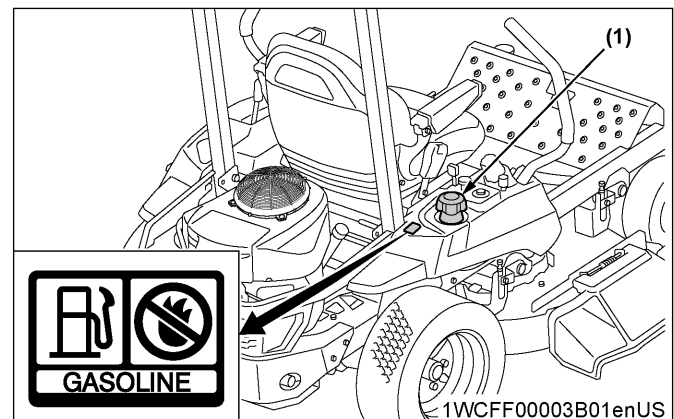

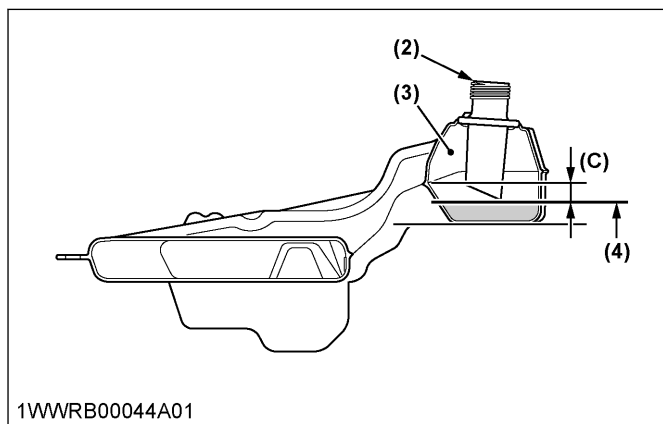

- | | |
|---------------------------|---------------------------------------|
| (1) Fuel tank cap | (C) Clearance |
| (2) Fuel tank filler neck | (fuel level is under the filler neck) |
| (3) Empty space | |
| (4) Maximum fuel level | |

Check the fuel level. Take care that the fuel tank does not become empty.

Fuel tank capacity	13.6 L (3.6 U.S.gals.)
--------------------	------------------------

IMPORTANT :

- Do not mix oil with gasoline.
- Tighten the fuel cap.
- Do not use a fuel cap other than one approved by Kubota.
- Do not permit dirt, trash or water to get into the fuel system.
- Be careful not to spill fuel while refueling. If a spill should occur, wipe it off at once, or it may cause a fire.
- Do not use old fuel.

Use only unleaded gasoline with an octane rating index of 87 or higher.

NOTE :

- Use fuel within approximately 30 days after purchase to avoid deterioration in fuel quality, or add fuel stabilizer to keep fuel fresh and stabilized.
- Fuel blend differs from season to season for the best seasonal engine performance. To prevent engine performance troubles such as vapor lock or hard starting, use fuel within the season in which the fuel is purchased.
- Infrequent use of the engine during a season can make fuel stale in the fuel tank of the machine. Stale fuel condition can cause engine performance troubles due to varnished and plugged carburetor components.
- Seal the fuel storage container tightly and store it out of sunlight and heat to prevent fuel degradation.
- Condensation in the fuel tank may occur because of various operating or environmental conditions. To reduce condensation and to

avoid affecting the machine operation, fill the fuel tank at the end of daily operations.

Use of alcohol mixed gasoline (gasohol)

Use "gasohol" only when the ethanol additive is 10 % or less of the fuel. The use of methanol additive is not recommended. For best results, use unleaded fuel with a minimum of 87 octane.

3. Checking and cleaning the air intake screen**! WARNING**

To avoid serious injury or death:

- Stop the engine and remove the key before cleaning.
- Make sure that the engine is cool to the touch before cleaning.

IMPORTANT :

- The air intake screen and air intake area must be clear of debris to prevent the engine from overheating.

Daily or after every 5 hours of operation, make sure the air intake screen and the air intake area are clean.

Dirt or chaff around the air intake screen, air intake area, or the engine cooling area decrease cooling performance.

1. Check that the air intake screen is clear of grass clippings and debris.
2. If the screen is dirty, clean it with a brush or cloth.
3. Remove the dust and all foreign material from the engine plate.

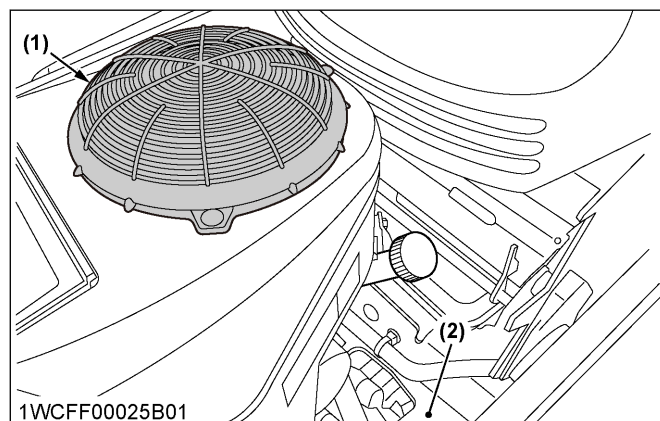

- (1) Air intake screen
- (2) Engine plate

4. Checking the tire pressure**! WARNING**

To avoid serious injury or death:

- Do not attempt to mount a tire on a rim. This should be done by a qualified person with the proper equipment.
- Always maintain the correct tire pressure. The inflation pressure in the front tires rises quickly when using compressed air. Do not inflate the tires above the recommended pressure shown in the Operator's Manual.

IMPORTANT :

- Do not use tires other than the size specified.

4.1 Inflation pressure

Even though the inflation pressure is factory-set to the prescribed level, it naturally drops slowly in the course of time. Therefore, check it everyday and inflate as necessary.

	Tire sizes	Recommended inflation pressure
Front	11 x 4 - 5, 4PR smooth	170 kPa (1.7 kgf/cm ² , 25 psi)
Rear	18 x 7.5 - 10, 4PR turf	83 kPa (0.9 kgf/cm ² , 12 psi)

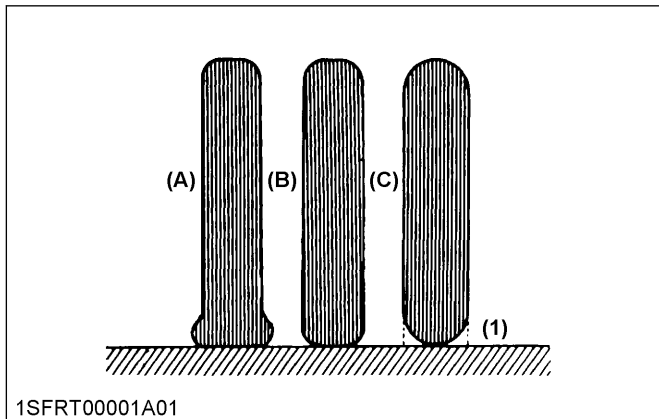

(1) Ground

- (A) "INSUFFICIENT"
- (B) "NORMAL"
- (C) "EXCESSIVE"

5. Checking movable parts

If any of the movable parts, such as levers and pedals, cannot be smoothly moved because of rust or anything sticky, do not attempt to force it into motion. In this case, remove the rust or the sticky object, and apply oil or grease on the relevant spot. Otherwise, the machine may get damaged.

EVERY 50 HOURS

1. Checking the engine start system

The engine start system in your machine is designed to protect you while operating. Check the engine start

system periodically (daily is best) to test the function of the engine start system before operation.

! WARNING

To avoid serious injury or death:

- Do not allow anyone near the machine while testing.
- If the machine does not pass one of the following tests, do not operate the machine. Consult your local Kubota Dealer.
- Sit on the operator's seat for all tests except for test 1.

IMPORTANT :

- Test the following before operating the machine:

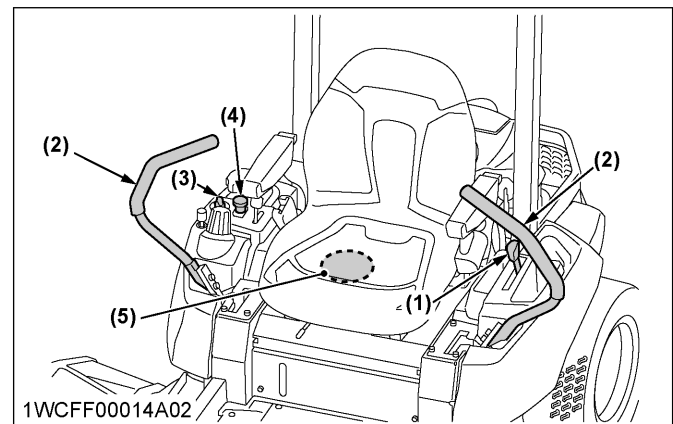

- (1) Parking brake lever
- (2) Motion control lever
- (3) Key switch
- (4) PTO switch
- (5) Seat switch

Test 1 (operator not on the seat)

1. Securely set the parking brake.
2. Set the PTO switch to the "DISENGAGE" (OFF) position.
3. Set the motion control levers to the "NEUTRAL LOCK" position.
4. Turn the key switch to the "START" position.
5. The engine must not crank.

Test 2 (operator on the seat)

1. Do not set the parking brake (release it from test 1).
2. Set the PTO switch to the "DISENGAGE" (OFF) position.
3. Set the motion control levers to the "NEUTRAL LOCK" position.
4. Turn the key switch to the "START" position.
5. The engine must not crank.

Test 3 (operator on the seat)

1. Securely set the parking brake.
2. Set the PTO switch to the "DISENGAGE" (OFF) position.

3. Grasp the motion control levers and move them inward from the "NEUTRAL LOCK" position to the "NEUTRAL" position and then release the levers.
4. Turn the key switch to the "START" position.
5. The engine must not crank.

Test 4 (operator on the seat)

1. Securely set the parking brake.
2. Set the PTO switch to the "ENGAGE" (ON) position.
3. Set the motion control levers to the "NEUTRAL LOCK" position.
4. Turn the key switch to the "START" position.
5. The engine must not crank.

NOTE :

- If the engine cranks in tests 1 through 4, consult your local Kubota Dealer to have the unit checked before operation.

Test 5 (operator on the seat)

1. Start the engine.
2. Keep the parking brake securely set.
3. Set the PTO switch to the "DISENGAGE" (OFF) position.
4. Grasp the motion control levers and move them inward from the "NEUTRAL LOCK" position to the "NEUTRAL" position and then release the levers.
5. The engine must shut off.

NOTE :

- If the engine keeps running in test 5, consult your local Kubota Dealer to have the unit checked before operation.

2. Checking the OPC system

The operator presence control (OPC) system in your machine is designed to protect you while operating. Check the OPC system periodically (daily is best) to test function of the OPC system before operation.

WARNING

To avoid serious injury or death:

- Do not allow anyone near the machine while testing.
- If the machine does not pass one of the following tests, do not operate the machine. Consult your local Kubota Dealer.

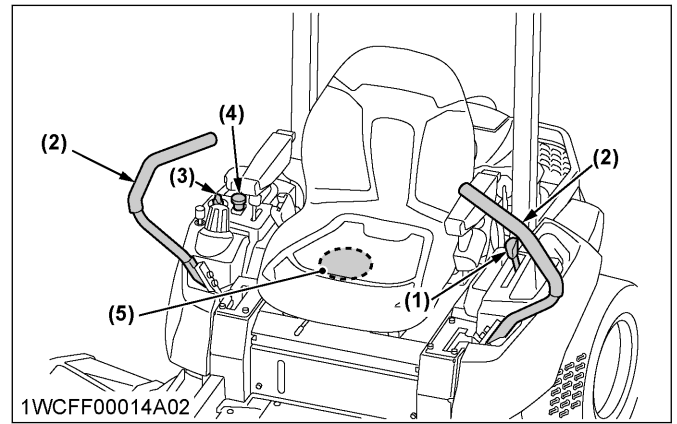

- (1) Parking brake lever
 (2) Motion control lever
 (3) Key switch
 (4) PTO switch
 (5) Seat switch

Test 1 (operator on the seat)

1. Start the engine.
2. Do not set the parking brake.
3. Keep the PTO switch to the "DISENGAGE" (OFF) position.
4. Stand up. Do not get off the machine.
5. The engine must shut off.

Test 2 (operator on the seat)

1. Start the engine.
2. Do not set the parking brake.
3. Keep the PTO switch to the "ENGAGE" (ON) position.
4. Stand up. Do not get off the machine.
5. The engine must shut off.

NOTE :

- If the engine keeps running in tests 1 through 2, consult your local Kubota Dealer to have the unit checked before operation.

3. Checking the muffler and spark arrester (if equipped)

WARNING

Running engines produce heat. Engine parts, especially the muffler, become extremely hot. Severe thermal burns can occur on contact. Combustible debris, such as leaves, grass, brush, and so on can catch fire.

To avoid serious injury or death:

- Allow the muffler, engine cylinder and fins to cool before touching.
- Remove accumulated debris from the muffler area and cylinder area.
- It is a violation of California Public Resource Code, Section 4442, to use or operate the engine on any forest-covered, brush-covered,

or grass-covered land unless the exhaust system is equipped with a spark arrester, as defined in Section 4442, maintained in effective working order. Other states or federal jurisdictions may have similar laws. Contact the original equipment manufacturer, retailer, or dealer to obtain a spark arrester designed for the exhaust system installed on this engine.

- Replacement parts must be of the same design and installed in the same position as the original parts. Other parts may not perform as well, may damage the unit, and may result in injury.

1. Remove accumulated debris from the muffler and cylinder area.
2. Inspect the muffler for cracks, corrosion, or other damage.
3. Remove the spark arrester, if equipped, and inspect for damage or carbon blockage.
4. If damage is found, install replacement parts before operating.

EVERY 100 HOURS

1. Changing the engine oil

WARNING

To avoid serious injury or death:

- Stop the engine and remove the key before changing the oil.
- Allow the engine to cool down sufficiently, as oil can be hot and may cause burns.

1. Insert the hose attached with the machine to the T-type pipe fitting on the right side of the engine. In case there is no hose attached, use a hose with an inner diameter of 0.5 in. and a length of about 150 mm (6 in.). Direct the hose down, loosen the nut of the T-type pipe fitting and drain the engine oil.

NOTE :

- The used oil can be drained out more easily if the engine is warm.

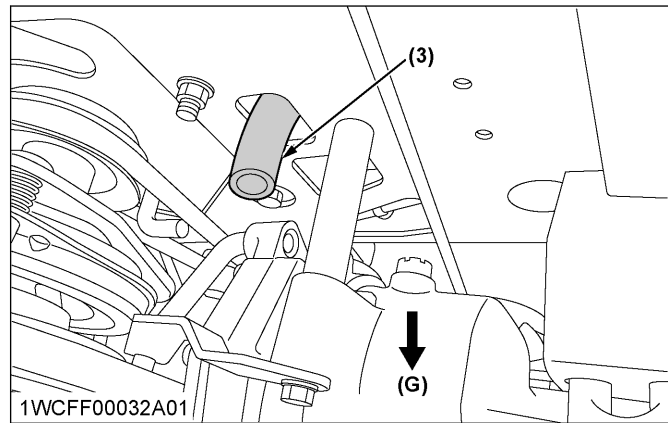
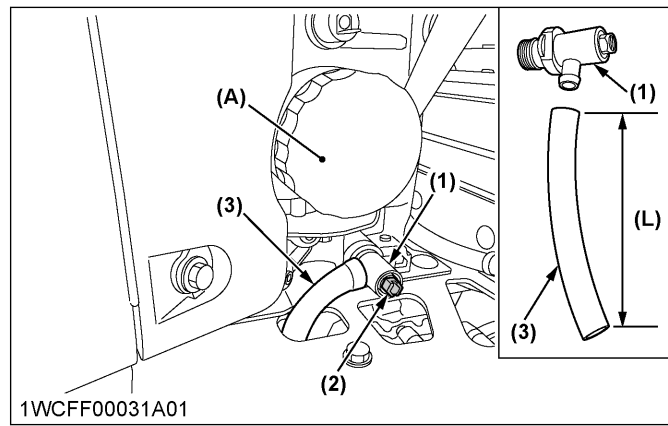

- (1) T-type pipe fitting
- (2) Nut
- (3) Hose
- (A) Engine
- (G) Ground
- (L) 150 mm (6 in.)

2. Tighten the nut of the T-type pipe fitting and fill with new oil up to the upper level on the dipstick.

Capacity with filter	2.1 L (2.2 U.S.qts)
----------------------	------------------------

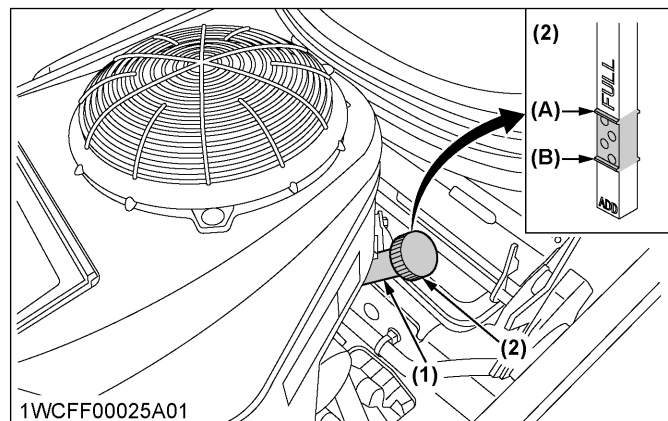

- (1) Engine oil port
- (2) Oil level dipstick
- (A) "UPPER LEVEL"
- (B) "LOWER LEVEL"

- To check the oil level:
Remove the dipstick, wipe it clean, insert it and draw it out again. Check to see that the oil level is between the 2 marks.

NOTE :

- Do not overfill.

2. Cleaning the air cleaner paper element

Every 100 hours of operation replace the paper element.

Check for a buildup of dirt and debris around the air cleaner system. Keep this area clean. Also check for loose or damaged components. Replace all bent or damaged air cleaner components.

- Lift up the tabs to open the air cleaner cover.

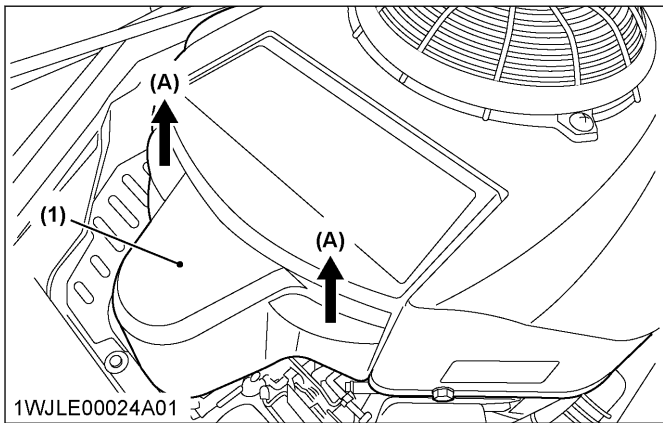

(1) Air cleaner cover (A) "LIFT UP"

- Remove the air cleaner paper element and the air intake hose.

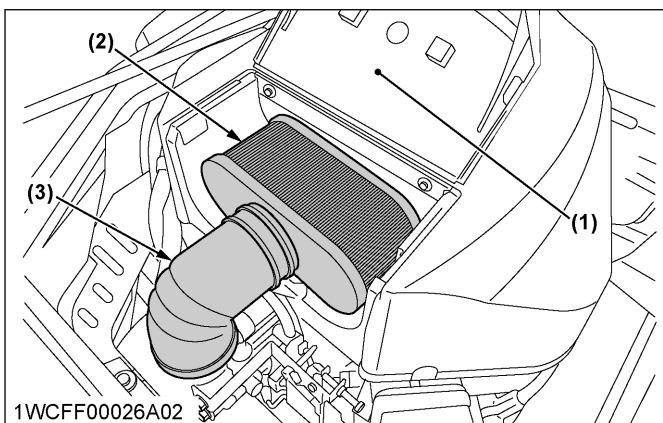

(1) Air cleaner cover
(2) Air cleaner paper element
(3) Air intake hose

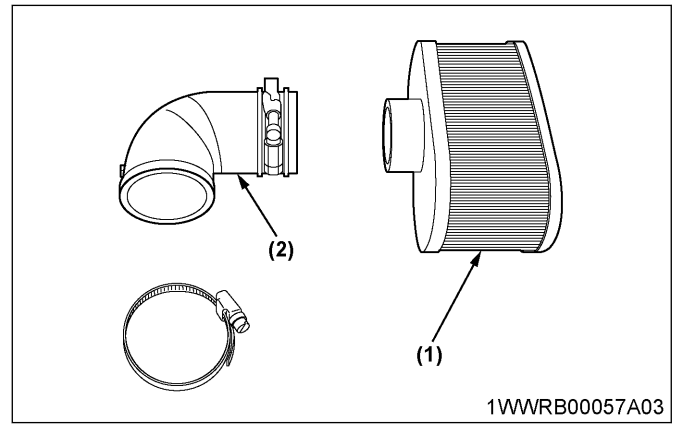

(1) Air cleaner paper element
(2) Air intake hose

- Clean the air cleaner base as required and check condition.

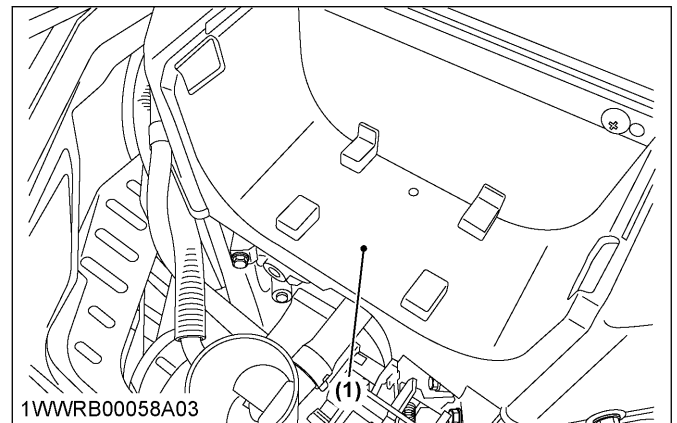

(1) Air cleaner base

- Reinstall the air cleaner paper element into the air intake hose, and reinstall them in place.
- Close the air cleaner cover.

NOTE :

- Operating the engine with loose or damaged air cleaner components could allow debris into the engine causing premature wear and failure.

3. Cleaning the engine cooling system

⚠ WARNING

To avoid serious injury or death:

- Make sure the engine is cool to the touch before removing shrouds.
- Always shield eyes and face when using compressed air to remove debris and objects.

1. Remove the engine shroud mounting bolts and detach the shroud.

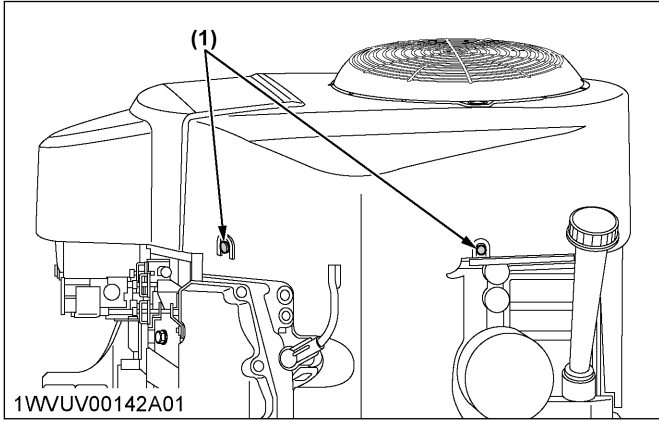

(1) Bolt

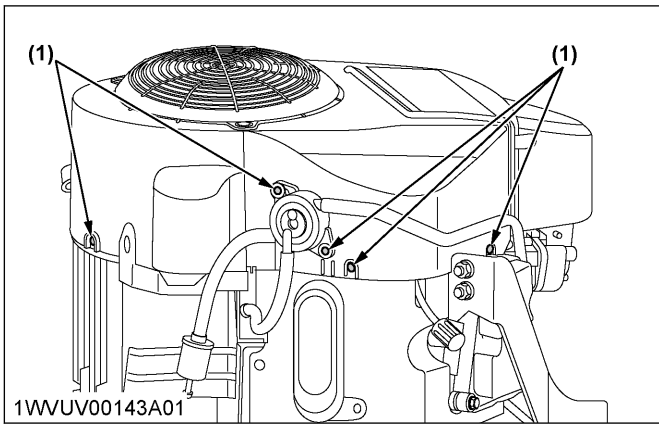

(1) Bolt

2. Check to see if the engine's cooling fins are blocked with dust and dirt. Clean them with compressed air if required.
3. After removing debris build up reinstall the plastic housing.

Tightening torque	8.8 N·m (0.90 kgf·m, 6.5 lbf·ft)
-------------------	-------------------------------------

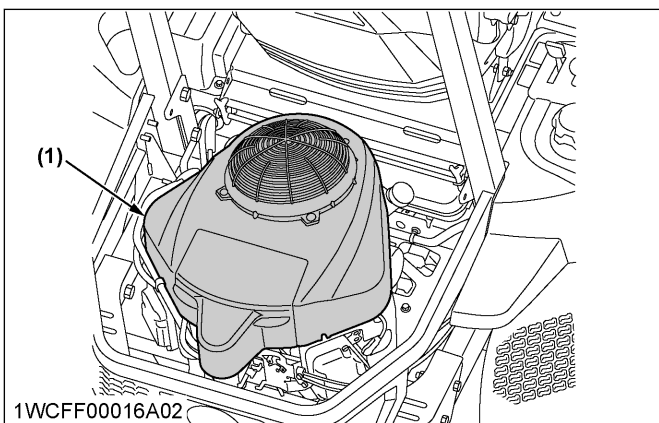

(1) Shroud

4. Checking the spark plug

Check the spark plug condition and gap every 100 hours of operation.

1. Remove the spark plug wire from the spark plug.
2. Use a spark plug wrench to remove the plug.

NOTE :

- This engine is equipped with a resistor-type spark plug.

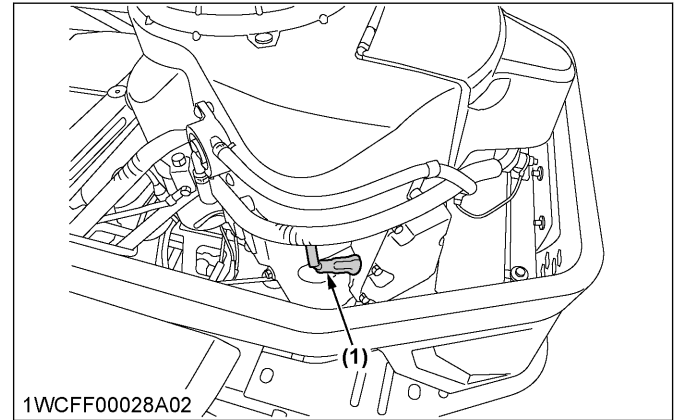

(1) Spark plug (both sides)

3. Clean the electrodes by scraping with a wire brush to remove carbon deposits.
4. Inspect the spark plug for cracked porcelain, pitted electrodes, or other wear and damage. Replace the spark plug if necessary.
5. Check the spark plug gap with a gap gauge.

Recommended spark plug	NGK BPR4ES
------------------------	------------

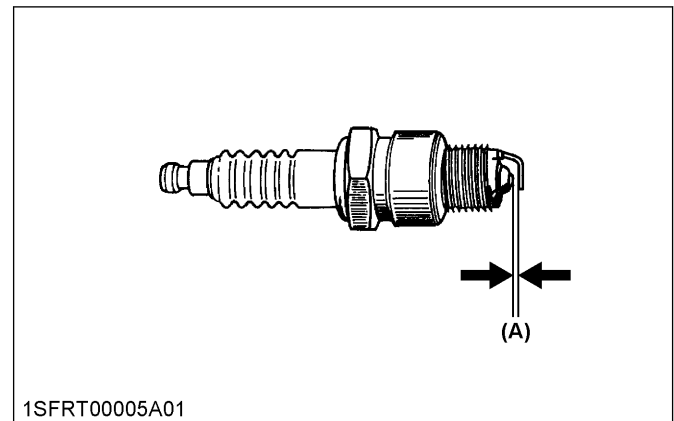

(A) 0.75 mm (0.03 in.)

Tightening torque	22 N·m (2.2 kgf·m, 16 lbf·ft)
-------------------	----------------------------------

5. Checking the fuel filter

Consult your local Kubota Dealer for this service.

6. Checking the battery condition

DANGER

To avoid the possibility of battery explosion:
For the refillable type battery, follow these instructions:

- Do not use or charge the refillable type battery if the fluid level is below the [LOWER] (lower limit level) mark. Otherwise, the battery component parts may prematurely deteriorate, which may shorten the battery's service life or cause an explosion.
- Check the fluid level regularly and add distilled water as required so that the fluid level is between the [UPPER] and [LOWER] levels.
- When the battery is being activated, hydrogen and oxygen gases in the battery are extremely explosive. Keep open sparks and flames away from the battery at all times, especially when charging the battery.

WARNING

To avoid serious injury or death:

- Batteries, battery posts, terminals and related accessories contain lead, lead compounds and other chemicals known to the State of California to cause cancer and birth defects or other reproductive harm. Wash hands after handling.
- Never remove the battery cap while the engine is running.
- Keep open sparks and flames away from the battery at all times. Hydrogen gas mixed with oxygen becomes very explosive.
- Wear eye protection and rubber gloves when working around the battery.

NOTE :

- The factory-installed battery is a non-refillable type.
If the battery is weak, charge the battery or replace it with a new one.

IMPORTANT :

- Mishandling the battery shortens the service life and adds to maintenance costs.
The original battery is maintenance free, but needs some servicing.
If the battery is weak, the engine will be difficult to start and the lights will be dim. It is important to check the battery periodically.
- When exchanging an old battery with a new one, use a battery of equal specifications (as described in the following table).

Battery type	Volts (V)	Reserve capacity (min)	Cold cranking amps	Normal charging rate (A)
U1-300	12	45	300	6.5

6.1 Non-accessible maintenance-free type batteries

Maintenance-free, non-accessible batteries are designed to eliminate the need to add water. Yet the volume of electrolyte above the plates may eventually become depleted due to abnormal conditions such as high heat or improper regulator settings.

6.2 Checking the battery voltage

Use a voltmeter to check the state of charge.
(See the following reference chart to determine if charging is necessary.)

Battery voltage	Reference state of charge
12.6	100 % (full charge)
12.4	75 %
12.2	50 %
12.0	25 %
11.8	0 %

6.3 Charging the battery

DANGER

To avoid serious injury or death:

- When the battery is being activated, hydrogen and oxygen gases in the battery are extremely explosive. Keep open sparks and flames away from the battery at all times, especially when charging the battery.

WARNING

To avoid serious injury or death:

- When disconnecting the cable from the battery, start with the negative terminal first. When connecting the cable to the battery, start with the positive terminal first.
- Never check the battery charge by placing a metal object across the posts.
Use a voltmeter or hydrometer.

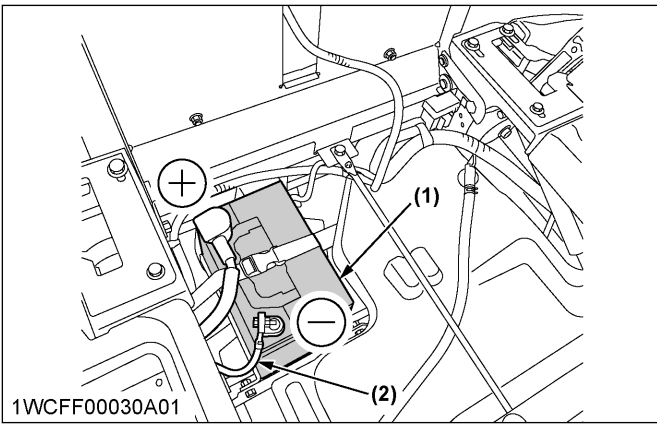

(1) Battery (+) Positive terminal
 (2) Ground cable (-) Negative terminal

1. To slow charge the battery, connect the battery positive terminal to the charger positive terminal and the negative to the negative. Then, charge for at least 1 hour at 6.5 amperes.
2. A boost charge is only for emergencies. It will partially charge the battery at a high rate and in a short time. When using a boost-charged battery, it is necessary to recharge the battery as early as possible. Failure to do this will shorten the battery's service life.

6.4 Storing the battery

1. When storing the machine for a long period, remove the battery from the machine and store in a dry place out of direct sunlight.

IMPORTANT :

- When removing the machine from the storage, reconnect the battery positive cable first, and then the negative cable.

Tightening torque	3 to 5 N·m (2.2 to 3.7 lbf·ft, 0.3 to 0.5 kgf·m)
-------------------	---

2. The battery self-discharges while it is stored. Recharge it once every 3 months in hot seasons and once every 6 months in cold seasons.

7. Adjusting the throttle cable

Consult your local Kubota Dealer for this service.

8. Adjusting the choke cable

Consult your local Kubota Dealer for this service.

EVERY 200 HOURS

1. Replacing the engine oil filter

! WARNING

To avoid serious injury or death:

- Engine oil is a toxic substance. Dispose of used oil properly. Contact your local authorities for approved disposal methods or possible recycling.
- Stop the engine and remove the key before changing the oil and the oil filter.
- Allow the engine to cool down sufficiently. Oil can be hot and may cause burns.

The oil filter must be changed every 200 service hours. Always use a genuine oil filter.

1. The drain plug is located on the starter side of the oil pan. Clean the area around the oil drain plug and the oil fill cap/dipstick.
2. Remove the drain plug and the oil fill cap/dipstick.
3. Allow the oil to drain and then reinstall the drain plug.
4. Remove the old filter and wipe off the filter adapter with a clean cloth.
5. Place a new replacement filter in a shallow pan with the open end up. Pour new oil, of the proper type, in the threaded center hole. Stop pouring when the oil reaches the bottom of the threads. Allow a few minutes for the oil to be absorbed by the filter material.
6. Apply a thin film of clean oil to the rubber gasket on the new oil filter.
7. Install the new oil filter to the filter adapter. Hand tighten the filter clockwise until the rubber gasket contacts the adapter, then tighten the filter an additional 3/4 to 1 turn.
8. Fill the engine with the proper oil to the **[FULL]** or **[F]** mark on the dipstick. Always check the oil level with the dipstick before adding more oil.
9. Reinstall the oil fill cap/dipstick and tighten securely.

10. Start the engine and check for oil leaks. Recheck the oil level before placing the engine into service. Stop the engine, correct any leaks, and allow a minute for the oil to drain down, then recheck the level on the dipstick.

NOTE :

- To prevent extensive engine wear or damage, always maintain the proper oil level in the crankcase. Never operate the engine with the oil level below the [ADD] or [L] mark or above the [FULL] or [F] mark on the dipstick.

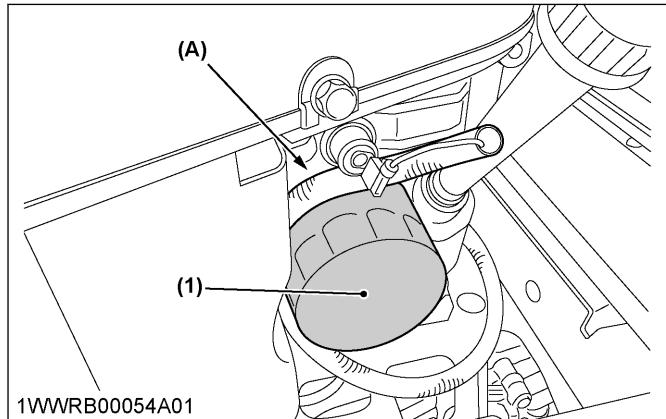

(1) Engine oil filter (A) "MOUNTING SURFACE"

2. Replacing the air cleaner paper element

Every 200 hours of operation replace the paper element.

1. Lift up the tabs to open the air cleaner cover.

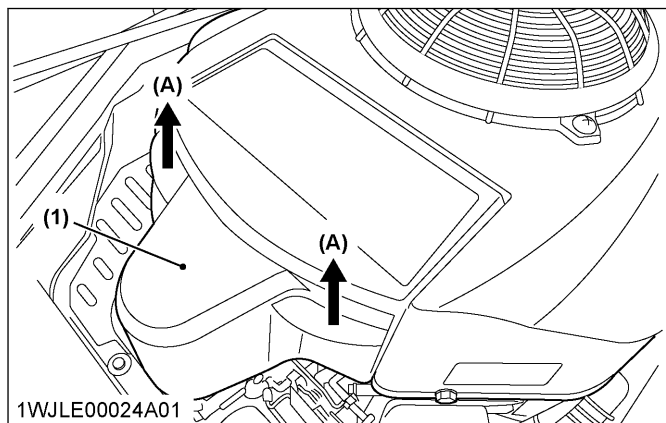

(1) Air cleaner cover (A) "LIFT UP"

2. Remove the air cleaner paper element and the air intake hose.

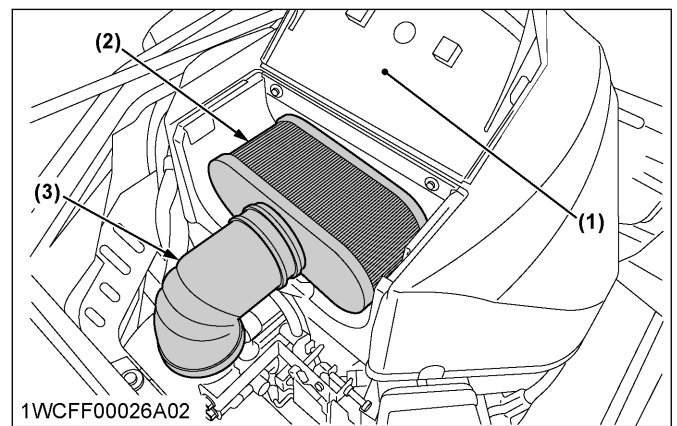

(1) Air cleaner cover
(2) Air cleaner paper element
(3) Air intake hose

3. Replace a dirty, bent, or damaged element with a genuine part. Handle the new element carefully; do not use if the sealing surfaces are bent or damaged.

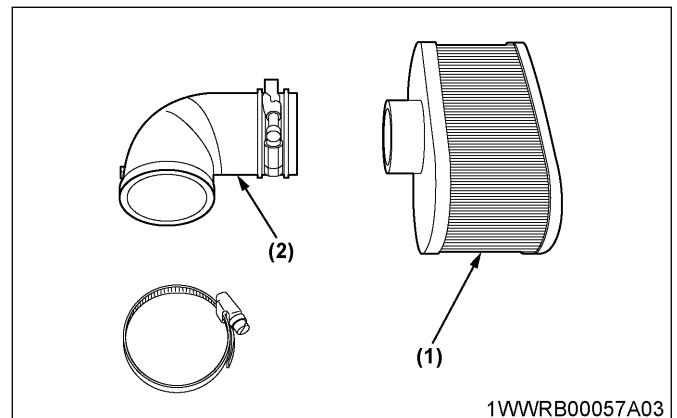

(1) Air cleaner paper element
(2) Air intake hose

4. Clean the air cleaner base as required and check condition.

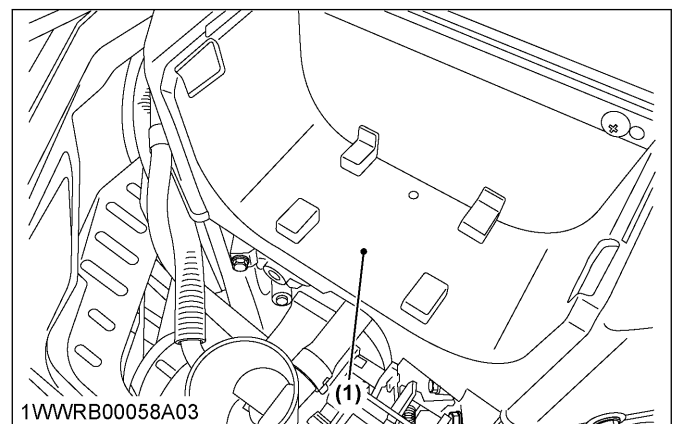

(1) Air cleaner base

5. Install the air cleaner paper element into the air intake hose, and reinstall them in place.

6. Close the air cleaner cover.

NOTE :

- Operating the engine with loose or damaged air cleaner components could allow debris into the engine causing premature wear and failure.

EVERY 300 HOURS

1. Cleaning the combustion chamber

Consult your local Kubota Dealer for this service.

2. Checking the valve seats and clearance

Consult your local Kubota Dealer for this service.

EVERY 1 YEAR

1. Checking the battery condition

(See Checking the battery condition on page 51.)

2. Checking fuel lines

⚠ WARNING

To avoid serious injury or death:

- Stop the engine and remove the key when attempting to make the following checks and changes.
- Fully raise the operator's seat to the resting position. Do not keep the seat halfway.
- Never fail to check the fuel lines periodically. The fuel lines are subject to wear and aging. Fuel may leak out onto the running engine, causing a fire.

The fuel line is made of rubber and ages regardless of service period.

1. If the fuel line, clamps and fuel filter are found damaged or deteriorated, consult your local Kubota Dealer.

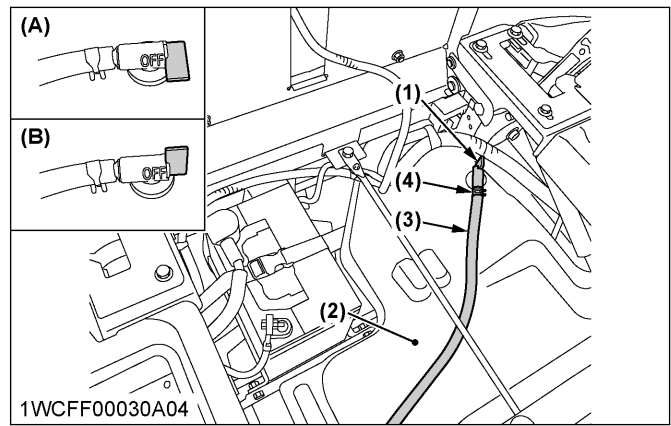

(1) Fuel valve
 (2) Fuel tank
 (3) Fuel line
 (4) Pipe clamp
 (A) "CLOSE" (OFF)
 (B) "OPEN"

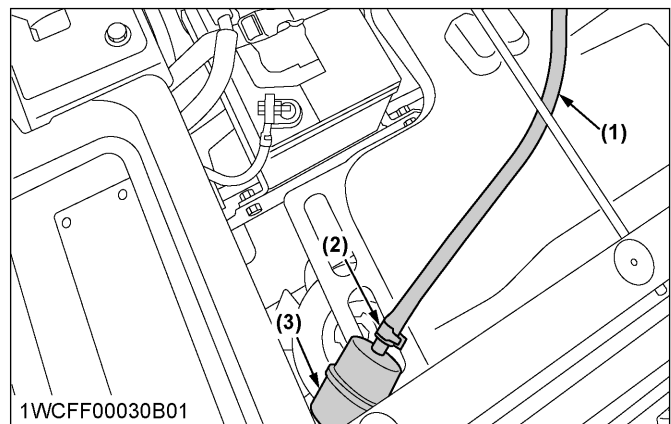

(1) Fuel line
 (2) Pipe clamp
 (3) Fuel filter

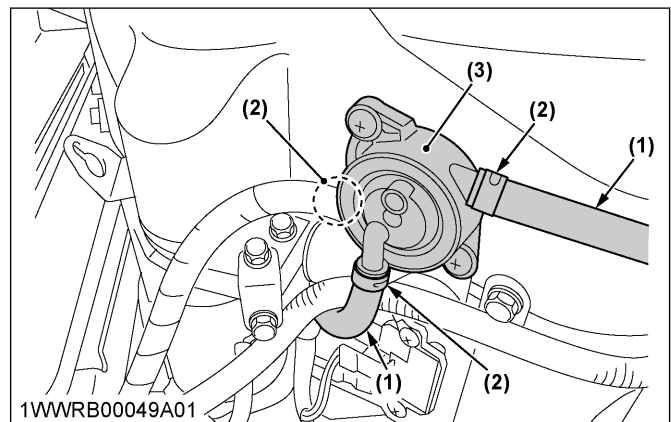

(1) Fuel line
 (2) Pipe clamp
 (3) Fuel pump

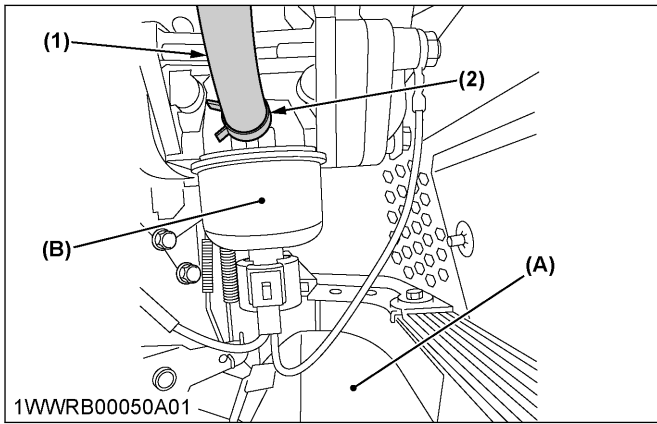

(1) Fuel line
(2) Pipe clamp
(A) Muffler
(B) Carburetor

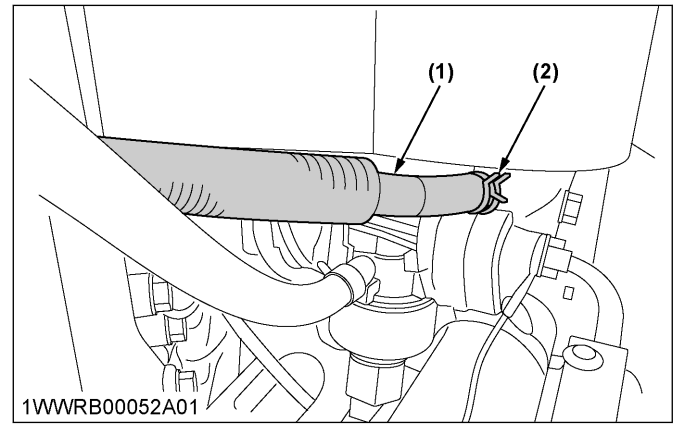

(1) Fuel line
(2) Pipe clamp

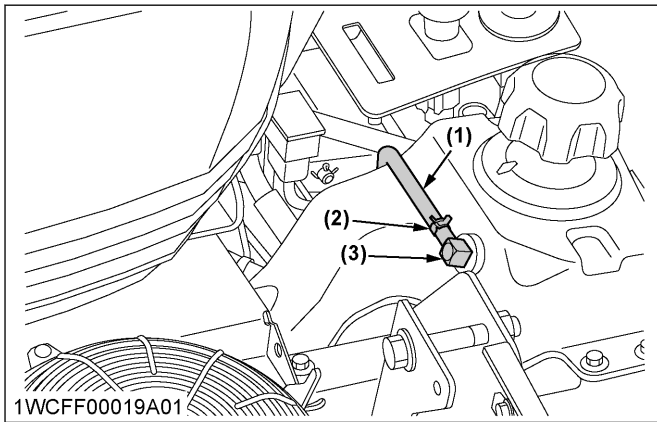

(1) Fuel line
(2) Pipe clamp
(3) 2 way valve (assembled in the fuel tank)

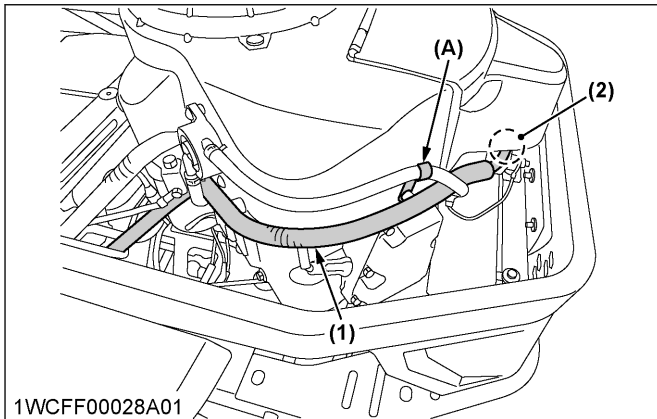

(1) Fuel line
(A) Clamp
(2) Pipe clamp

3. Checking the muffler and spark arrester (if equipped)

(See Checking the muffler and spark arrester (if equipped) on page 47.)

4. Changing the engine oil

(See Changing the engine oil on page 48.)

EVERY 4 YEARS

1. Replacing the fuel lines

Consult your local Kubota Dealer for this service.

SERVICE AS REQUIRED

1. Replacing fuses

1. Raise the operator's seat.
2. Remove the blown fuse.
3. Place a new fuse of the same capacity in position.

IMPORTANT :

- If the new fuse happens to blow out within a short time, contact your dealer for inspection and repair. Never “jump” the fuse with wire or foil, or install a larger capacity fuse than is recommended.

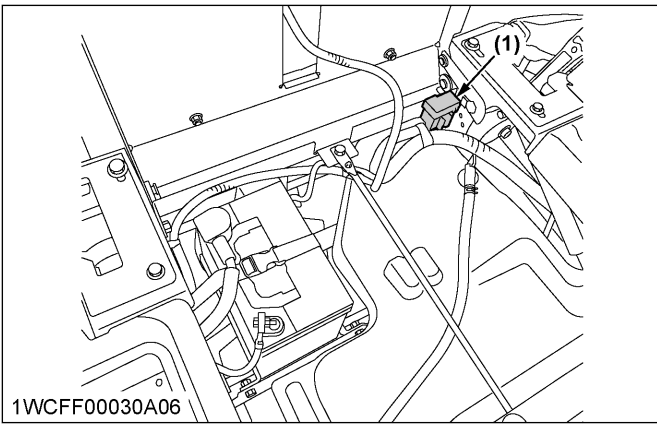

(1) Fuse location

Protected circuit

Fuse box

Capacity	Protected circuit
25 A	Charge
25 A	Main power
10 A	Start
15 A	ACC
10 A	PTO
5 A	OPC (Operator's presence control)

2. Checking and replacing blades

WARNING

To avoid serious injury or death:

- Stop the engine and remove the key.
- Blades may be sharp. When you handle blades, wear heavy gloves or wrap the end of the blades with a rag.
- If you feel you are unable to make the following adjustments correctly and safely, contact your local Kubota Dealer.

Mower deck cleaning

- Before checking or replacing the blades, wipe grass and mud off the top and inside of the mower. Especially, clean inside the belt cover, otherwise the belt life will be reduced.

Checking the blade

The blade cutting edges should be kept sharp at all times.

1. Sharpen the cutting edges if they look like the blade (B).
2. Replace the blades if they look like the blade (C).

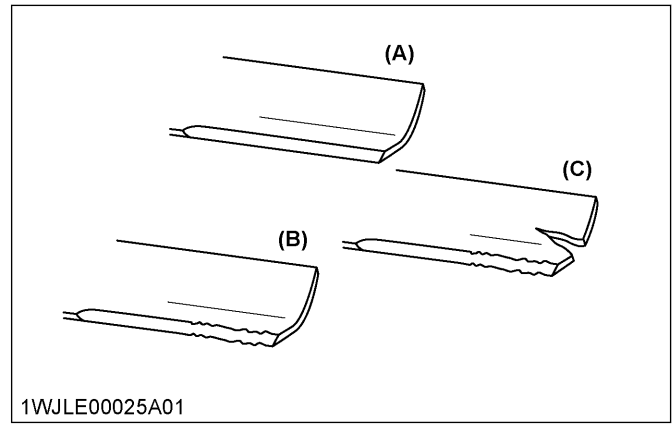

1WJLE00025A01

- (A) New blade
- (B) Worn blade
- (C) Cracked blade

Replacing

1. To prevent the spindle from rotating while removing the blade bolts, perform one of the next methods:
 - Wedge a block of wood between the blade and mower housing.
 - Use a box wrench over the pulley nut. Then, loosen the blade bolt as illustrated.

IMPORTANT :

- Use the proper metric size box or socket wrench to tighten or loosen the blade mounting bolt.

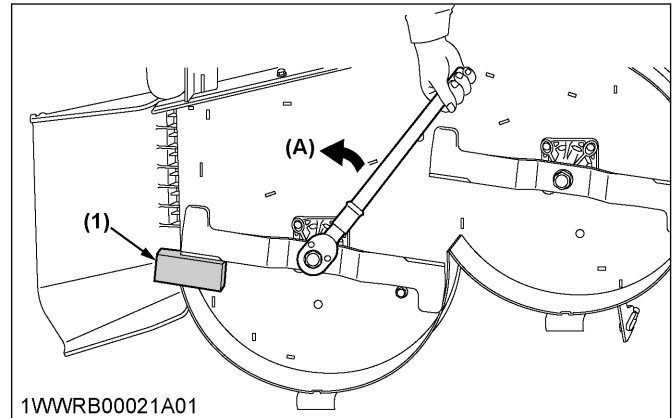

1VWWRB00021A01

(1) Block

(A) "LOOSEN"

2. To sharpen the blades yourself, clamp the blade securely in a vise. Use a large mill file and file along the original bevel until sharp.
3. To check the blade for balance, place a small rod through the center hole. If the blade is not balanced, file the heavy side of the blade until balance is achieved.

IMPORTANT :

- Not balancing the blades could cause abnormal vibration and/or damage to the mower spindle bearings and mower belt system.

4. Before installing blades, clean any debris and grass from inside the cover. If the cover is damaged, replace with a new one.
Install the cover between the spindle holder and blade.
To attach blades, install the cup washers between the blade and bolt head.
Then tighten the bolt securely.

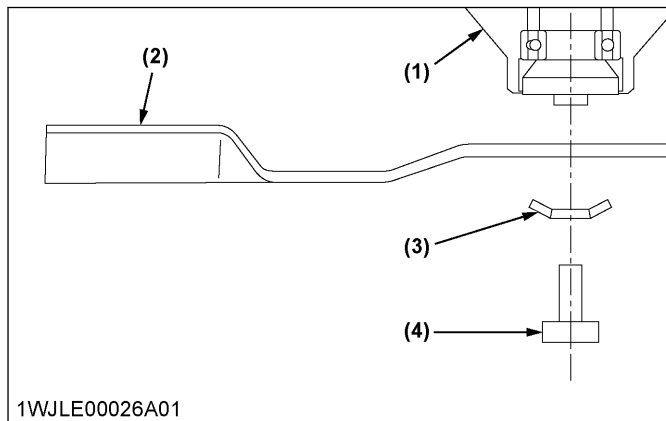

1WJLE00026A01

- (1) Spindle holder
- (2) Blade
- (3) Cup washer
- (4) Bolt

IMPORTANT :

- Tighten the blade bolts from 103 to 118 N·m (76 to 87 lbf·ft) of torque.
- The blade bolts have right hand threads. Turn them counterclockwise to loosen.
- To prolong the service life of the blades, reposition them as shown in the following figure periodically.

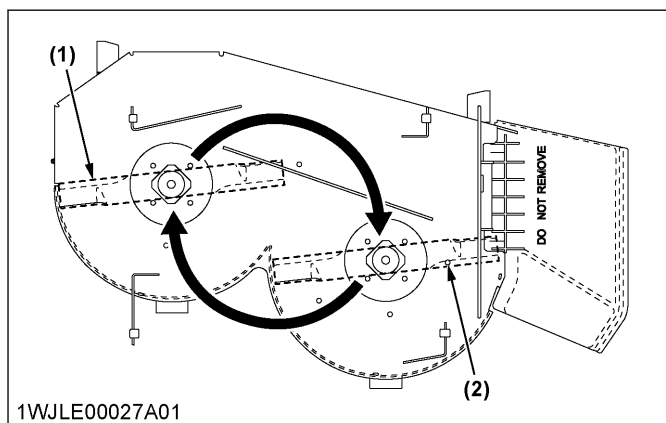

1WJLE00027A01

- (1) LH blade
- (2) RH blade

3. Replacing the mower belt

1. Remove the mower deck from the machine.
(See DISMOUNTING THE MOWER DECK on page 23.)

2. Remove the left and right hand mower belt covers from the mower deck.
3. Remove the tension pulley, and remove the belt.
4. Attach the new belt and attach the tension pulley.

NOTE :

- Tighten the tension pulley bolt securely from 77.6 to 90.2 N·m (8.0 to 9.2 kgf·m).

5. Install the left and right hand mower belt covers to the mower deck.
6. Attach the mower deck to the machine.
(See MOUNTING THE MOWER DECK on page 22.)

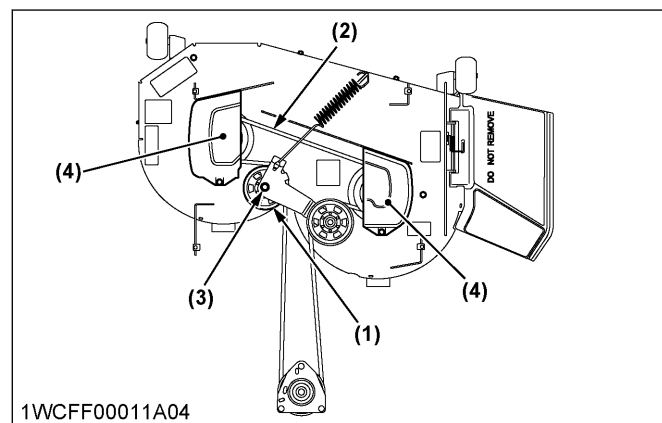

1WCFF00011A04

- (1) Tension pulley
- (2) Belt
- (3) Bolt
- (4) Mower belt cover

4. Adjusting the electric clutch

Consult your local Kubota Dealer for this service.

ADJUSTMENT

MOTION CONTROL LEVER

WARNING

To avoid serious injury or death:

- Park the machine on a firm and level surface.
- If it is necessary to run the engine indoors, use a gas tight exhaust pipe extension to remove the fumes.
- Always try to work in a well-ventilated area.
- Lift up and secure with jack stands or by blocking the rear of the machine. Do not run the machine while adjusting. Remove the rear wheels.
- Do not make only one of the following adjustments (except "MOTION CONTROL LEVER ALIGNMENT"). They are interlinked.
- If you feel you are unable to make the following adjustments correctly and safely, contact your local Kubota Dealer.

IMPORTANT :

- Right and left motion control levers can be adjusted independently.

1. Adjusting HST neutral position

Consult your local Kubota Dealer for this service.

2. Adjusting maximum speed (forward)

Consult your local Kubota Dealer for this service.

3. Motion control lever alignment

WARNING

To avoid serious injury or death:

- Park the machine on a firm and level surface.
- Stop the engine, remove the key and apply the parking brake.

3.1 Checking the alignment

1. Check the gap and space between the levers at the maximum forward position.

Recommended gap:	0 to 2 mm (0 to 0.08 in.)
------------------	------------------------------

If the positions of the motion control levers are unequal, adjustment is necessary.

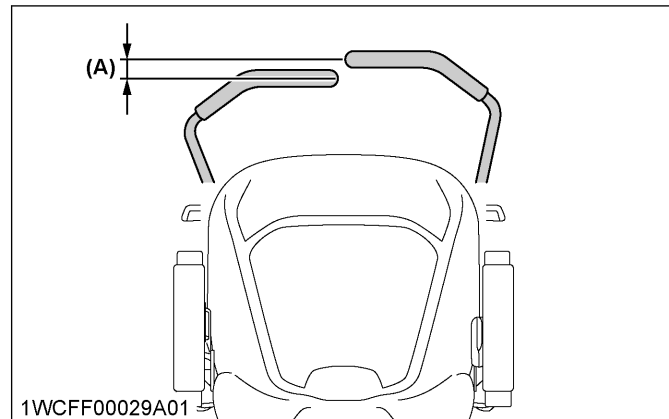

(A) "GAP"

3.2 Aligning the motion control levers

1. Stop the engine and apply the parking brake.

Lever position (high or low)

1. Remove the bolts and select the motion control lever position, high or low.
2. Tighten the bolts.

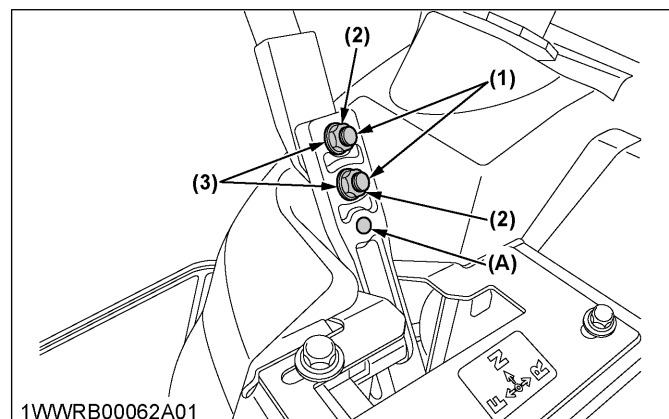

- (1) Bolt
(2) Flange nut
(3) Tab slot

(A) Low position

Lever alignment (right and left)

1. Loosen the bolts.
2. Slide both levers forward or rearward to the desired position within tab slots until the levers are aligned.
3. Tighten the bolts.

MOWER DECK LEVEL

1. Anti-scalp rollers

WARNING

To avoid serious injury or death:

- Park the machine on a firm and level surface.
- Apply the parking brake.
- Stop the engine and remove the key.
- Wait for all moving parts to stop.

NOTE :

- The flattest cut can be achieved by having the anti-scalp rollers adjusted off the ground. Check the anti-scalp roller adjustments each time the mower deck cutting height is changed. It is recommended that all the anti-scalp rollers be kept off the ground to minimize scuffing.
1. Check the machine tire pressure. Inflate tires to the correct pressure. (See TIRES AND WHEELS on page 39.)
 2. Raise up the mower deck to the end of travel (the highest cutting height (4.25 in.)).
 3. Turn the cutting height control dial to adjust the height to the desired level.
 4. Lower the mower deck.
 5. Adjust the height of the front side anti-scalp roller to 1 of the 4 positions, to approximately 19 mm (0.75 in.) between the rollers and the ground. Adjust the other roller to the same height.

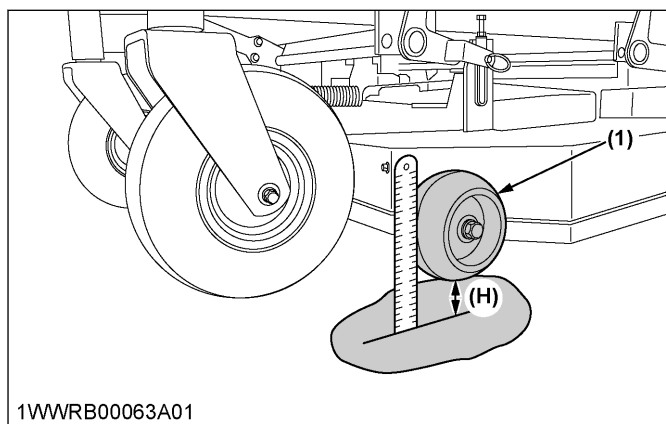

(1) Front side anti-scalp roller (H) 19 mm (0.75 in.)

6. Install the roller with the attaching hardware.

2. Leveling the mower deck (side-to-side)

WARNING

To avoid serious injury or death:

- Park the machine on a firm and level surface.
- Apply the parking brake.
- Disengage the PTO (OFF).

- Stop the engine and remove the key while checking or adjusting the level of the mower deck.

IMPORTANT :

- Check the machine tire pressure. Inflate the tires to the correct pressure. (See TIRES AND WHEELS on page 39.)

2.1 Checking the level (side-to-side)

NOTE :

- The mower deck anti-scalp rollers should not contact the ground.
1. Raise the mower deck to the end of travel (the highest cutting height (4.25 in.)).
 2. Turn the cutting height set dial to the 76 mm (3 in.) cutting height position.
 3. Lower the mower deck.
 4. Position the right mower blade in the side-to-side position.
 5. Measure from outside the blade tip to the level surface with a short ruler or leveling gauge.

Reference

Height of the blade at the flat surface	76 mm (3 in.)
---	---------------

NOTE :

- Take the measurements on a flat surface.
6. Check that the left side blade has the same height. The difference between both measurements is less than 3 mm (0.125 in.).
 7. If the side-to-side adjustment is not within the given tolerance, adjustment is necessary.

Side-to-side adjustment	Less than 3 mm (0.125 in.)
-------------------------	----------------------------

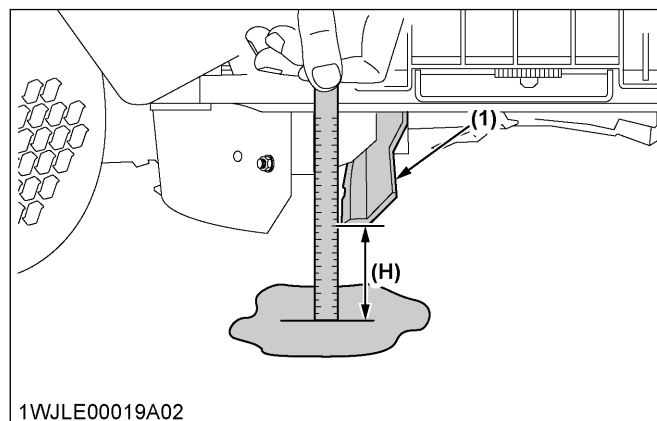

(1) Blade (H) 76 mm (3 in.)

2.2 Adjusting the level (side-to-side)

1. Raise up the mower deck to the end of travel (the highest cutting height (4.25 in.)).
2. Turn the cutting height set dial to the 76 mm (3 in.) cutting height position.
3. Place 51 mm (2 in.) high wood blocks under each side of the mower deck.
Anti-scalp rollers must not rest on the wood block.
4. Lower the mower deck.
5. Position the mower blade in the side-to-side position.
6. Loosen the jam nuts of the right side of the machine.
7. Adjust the cutting height fine tuning bolts to set 76 mm (3 in.) blade height.
Front and rear side bolts must be adjusted.
8. Jam the nuts.
9. Adjust the left side equally.
10. Check the side-to-side level. If it is not level, adjustment is necessary.

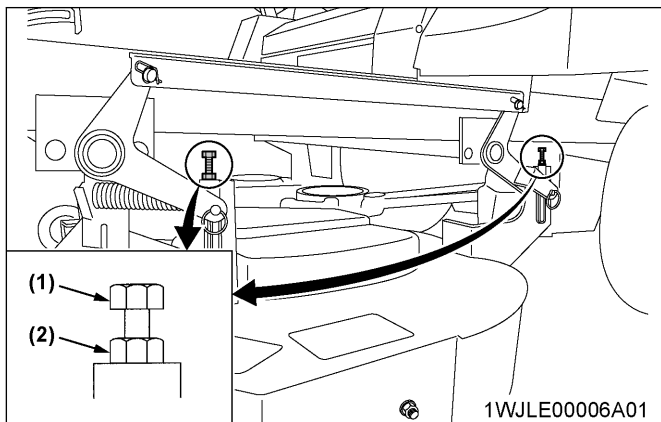

- (1) Cutting height fine tuning bolt
(2) Jam nut

3. Leveling the mower deck (front-to-rear)

WARNING

To avoid serious injury or death:

- Park the machine on a firm and level surface.
- Engage the parking brake.
- Disengage the PTO.
- Stop the engine and remove the key while checking or adjusting the level of the mower deck.

IMPORTANT :

- Check the machine tire pressure.
Inflate the tires to the correct pressure.
(See TIRES AND WHEELS on page 39.)

3.1 Checking the level (front-to-rear)

NOTE :

- The mower deck anti-scalp rollers should not contact the ground.
1. Raise the mower deck to the end of travel (the highest cutting height (4.25 in.)).
 2. Turn the cutting height set dial to the 76 mm (3 in.) cutting height position.
 3. Lower the mower deck.
 4. Position the right mower blade in the front-to-rear position.
 5. Measure from the right front blade tip to the level surface with a short ruler or leveling gauge.
 6. Turn the blade 180° and measure from the right rear blade tip to the level surface.
 7. Check that the left side blade has the same dimensions. The difference between both measurements should be less than 6 mm (0.25 in.). The front side must be lower than the rear side.
 8. If the front-to-rear adjustment is not within the given tolerance, adjustment is necessary.

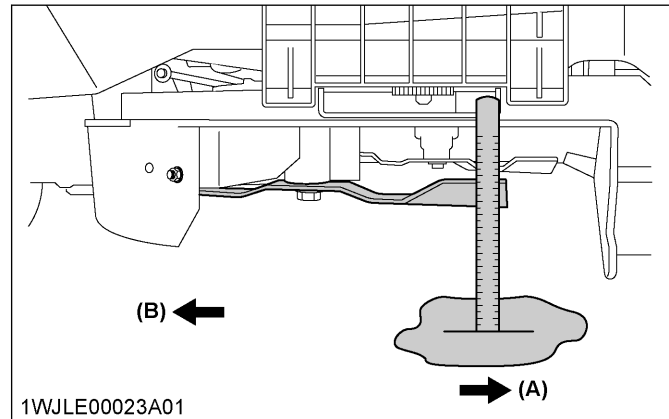

- (A) Front
(B) Rear

Front-to-rear adjustment	Less than 6 mm (0.25 in.) The front side must be lower than the rear side.
--------------------------	---

3.2 Adjusting the level (front-to-rear)

1. Raise up the mower deck to the end of travel (the highest cutting height (4.25 in.)).
2. Turn the cutting height set dial to the 76 mm (3 in.) cutting height position.
3. Place 51 mm (2 in.) high wood blocks under each side of the mower deck.
Anti-scalp rollers must not rest on the wood block.
4. Lower the mower deck.
5. Loosen the jam nuts of the front side of the machine.

6. Adjust the cutting height fine tuning bolts to set 76 mm (3 in.) blade height.
Both front side bolts must be adjusted.
7. Jam the nuts.
8. Adjust the other side equally.

IMPORTANT :



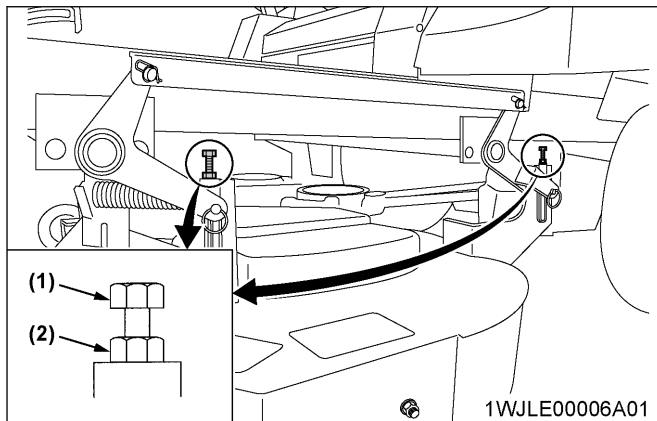

- The front position of the blades should be lower than the rear position of the blades and the difference between front and rear should not exceed 6 mm (0.25 in.).

9. Check the front-to-rear level. If it is not level, adjustment is necessary.



- (1) Cutting height fine tuning bolt
- (2) Jam nut

GENERAL TIGHTENING TORQUE SPECIFICATION

American standard cap screws with UNC or UNF threads				Metric cap screws		
SAE grade no.	GR.5 	GR.8 	Property class	Class 8.8 	Class 10.9 	
1/4	(lbf·ft) 8-9.6 (N·m) 10.7-12.9 (kgf·m) 1.11-1.33	12-14.4 16.1-19.3 1.66-1.99	M6	(lbf·ft) 7.2-8.3 (N·m) 9.81-11.3 (kgf·m) 1.0-1.15		
5/16	(lbf·ft) 17-20.5 (N·m) 23.1-27.8 (kgf·m) 2.35-2.84	24-29 32.5-39.3 3.31-4.01	M8	(lbf·ft) 17.4-20.2 (N·m) 23.6-27.4 (kgf·m) 2.4-2.8	21.7-25.3 29.4-34.3 3.0-3.5	
3/8	(lbf·ft) 35-42 (N·m) 47.5-57.0 (kgf·m) 4.84-5.82	45-54 61.0-73.2 6.22-7.47	M10	(lbf·ft) 35.5-41.2 (N·m) 48.1-55.8 (kgf·m) 4.9-5.7	44.9-52.1 60.8-70.5 6.2-7.2	
1/2	(lbf·ft) 80-96 (N·m) 108.5-130.2 (kgf·m) 11.07-13.29	110-132 149.2-179.0 15.22-18.27	M12	(lbf·ft) 57.2-66.5 (N·m) 77.5-90.1 (kgf·m) 7.9-9.2	76.0-86.8 103-117 10.5-12.0	
9/16	(lbf·ft) 110-132 (N·m) 149.2-179.0 (kgf·m) 15.22-18.27	160-192 217.0-260.4 22.14-26.57	M14	(lbf·ft) 91.2-108 (N·m) 124-147 (kgf·m) 12.6-15.0	123-144 167-196 17.0-20.0	
5/8	(lbf·ft) 150-180 (N·m) 203.4-244.1 (kgf·m) 20.75-24.91	220-264 298.3-358.0 30.44-36.53	M16	(lbf·ft) 145-166 (N·m) 196-225 (kgf·m) 20.0-23.0	192-224 260-303 26.5-31.0	

Thread size d (mm)	Hex. bolt head size B (mm)	No mark			7T		
		lbf·ft	N·m	kgf·m	lbf·ft	N·m	kgf·m
M8	12 or 13	13.0-15.2 (14.1 ± 1.1)	17.8-20.6 (19.2 ± 1.4)	1.9-2.1 (2.0 ± 0.1)	17.5-20.3 (18.9 ± 1.4)	23.5-27.5 (25.5 ± 2.0)	2.4-2.8 (2.6 ± 0.2)
M10	14 or 17	28.9-33.3 (31.1 ± 2.2)	39.3-45.1 (42.2 ± 2.9)	4.0-4.6 (4.3 ± 0.3)	35.4-41.2 (38.3 ± 2.9)	48.1-55.9 (52.0 ± 3.9)	4.9-5.7 (5.3 ± 0.4)
M12	17 or 19	46.3-53.5 (49.9 ± 3.6)	62.8-72.6 (67.7 ± 4.9)	6.4-7.4 (6.9 ± 0.5)	57.1-66.5 (61.8 ± 4.7)	77.6-90.2 (83.9 ± 6.3)	8.0-9.2 (8.6 ± 0.6)
M14	19 or 22	79.6-92.6 (86.1 ± 6.5)	107.9-125.5 (116.7 ± 8.8)	11.0-12.8 (11.9 ± 0.9)	91.1-108.5 (99.8 ± 8.7)	123.6-147.0 (135.3 ± 11.7)	12.6-15.0 (13.8 ± 1.2)

NOTE :

- Figure [7] on the top of the bolt indicates that the bolt is made of special material.
- Before tightening, check the figure on top of the bolt.

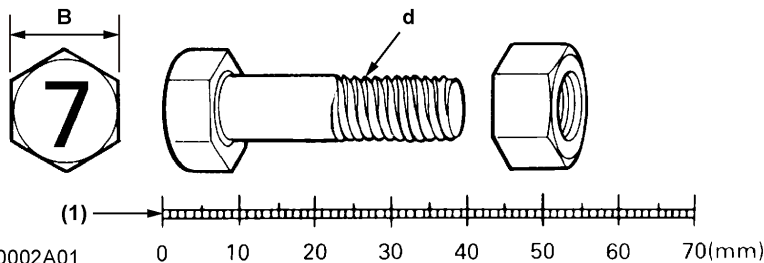

1SFRT00002A01

(1) Scale

STORAGE



WARNING

To avoid serious injury or death:

- To reduce fire hazards, allow the engine and the exhaust system to cool before storing the machine indoors or near combustible materials.
- To avoid the danger of exhaust fume poisoning, do not operate the engine indoors without proper ventilation.
- Do not clean the machine with the engine running.
- To avoid fire hazards, do not leave grass and leaves in the mower and the grass catcher.
- When storing, remove the key from the key switch to avoid operation by unauthorized persons.

STORING THE MACHINE

When the machine will not be operated for over 2 months, clean the machine and perform the following operations before storage:

1. Repair parts as necessary.
2. Check bolts and nuts and tighten as necessary.
3. Apply grease or engine oil to parts most likely to rust.

NOTE :

- **Never apply grease or oil to the muffler or hot parts.**
4. Inflate the tires to a little above the standard pressure levels (approximately 110 %).
 5. Lower the mower to the ground.
 6. Remove the battery from the machine, recharge it and store in a cool dry place.
The battery discharges over time even while in storage. Recharge it once a month in the hot season and once every 2 months in the cold season.
 7. Drain the fuel tank, fuel lines and carburetor or use a fuel stabilizer to prevent deterioration of the gasoline. If you choose to use a fuel stabilizer, follow the manufacturers recommendations and add the correct amount for the capacity of the fuel system. Fill the fuel tank with clean, fresh gasoline. Run the engine for 2 to 3 minutes to get stabilized fuel into the carburetor.
 8. Store the machine in a dry place sheltered from rain. Cover the machine with a vinyl tarp.

9. Moisture content in most grasses can damage the mower and grass catcher if these components are not properly cleaned after use.
Make sure the mower and the grass catcher are clean and completely empty before storage.

REMOVING THE MACHINE FROM STORAGE

1. Check the tire inflation pressure and adjust as required.
2. Install the battery. Before installing the battery, be sure it is fully charged.

Tightening torque	3 to 5 N·m (2.2 to 3.7 lbf·ft, 0.3 to 0.5 kgf·m)
-------------------	---

IMPORTANT :

- **Connect the battery positive cable first, and then the negative cable.**
3. Do the daily check.
(See DAILY CHECK on page 43.)
 4. Check all fluid levels (engine oil).
 5. Start the engine. Shut the engine off, walk around the machine and make a visual inspection looking for leakage of oil or other fluids.
 6. Run the engine a couple of minutes before you put the engine under load.

TROUBLESHOOTING

ENGINE TROUBLESHOOTING

If something is wrong with the engine, refer to the following table for the cause and its corrective measure.

Symptom (if)	Cause	Remedy
The engine is difficult to start or will not start.	• No operator on the seat.	• Sit on the operator's seat.
	• Parking brake lever not in the proper position.	• Apply the parking brake.
	• PTO switch not in the proper position.	• Make sure the PTO switch is in the "DISENGAGED" (OFF) position.
	• The motion control levers not in the proper position.	• Make sure motion control levers are in the "NEUTRAL LOCK" position.
	• The key switch not in the proper position.	• Make sure the key switch is in the "ON" position.
	• No fuel.	• Fill with fuel.
	• Improper or stale fuel (fuel quality is poor).	• Replace fuel and the fuel filter.
	• Water or dirt in the fuel system.	• Replace fuel and see your Kubota Dealer.
	• Fuel hose or fuel filter clogged or damaged.	• Clean or replace fuel lines and see your Kubota Dealer.
	• Air cleaner clogged.	• Clean or replace the air cleaner.
	• Spark plug damaged.	• Adjust the spark plug gap or replace the spark plug.
		• Check the spark plug wire connection.
	• Fuse blown.	• Replace the fuse.
	• The engine oil viscosity is wrong.	• Use oils of different viscosities, depending on the ambient temperature.
	• The battery becomes weak and the engine does not turn over quick enough.	• Clean battery cables and terminals.
		• Charge the battery.
		• In cold weather, always remove the battery from the engine, charge and store it indoors. Install it on the machine only when the machine is going to be used.
• Over choking or choke adjusted incorrectly.	• Check and see your Kubota Dealer.	
• Fuel valve is closed.	• Open fuel valve.	
• Cold weather.	• Follow the cold weather starting procedure.	
	• Charge the battery sufficiently.	
	• Use the proper engine lubricant.	
Insufficient engine power.	• Insufficient or dirty fuel.	• Check the fuel system.
	• Fuel filter clogged.	• Replace the fuel filter.
	• Air cleaner clogged.	• Clean or replace the air cleaner.
	• Spark plug damaged.	• Adjust the spark plug gap or replace it.

(Continued)

Symptom (if)	Cause	Remedy
The engine stops suddenly.	<ul style="list-style-type: none"> • Insufficient fuel. 	<ul style="list-style-type: none"> • Refuel.
		<ul style="list-style-type: none"> • Check the fuel valve position.
		<ul style="list-style-type: none"> • Check the carburetor fuel valve position.
Rough engine running.	<ul style="list-style-type: none"> • Spark plug damaged. 	<ul style="list-style-type: none"> • Adjust the spark plug gap or replace it.
	<ul style="list-style-type: none"> • Spark plug wire damaged. 	<ul style="list-style-type: none"> • See your Kubota Dealer.
	<ul style="list-style-type: none"> • Carburetion problems. 	<ul style="list-style-type: none"> • See your Kubota Dealer.
	<ul style="list-style-type: none"> • Ignition coil damaged. 	<ul style="list-style-type: none"> • See your Kubota Dealer.
	<ul style="list-style-type: none"> • Choke adjusted incorrectly. 	<ul style="list-style-type: none"> • See your Kubota Dealer.
	<ul style="list-style-type: none"> • Fuel hose or fuel filter clogged or damaged. 	<ul style="list-style-type: none"> • Clean or replace fuel lines and see your Kubota Dealer.
	<ul style="list-style-type: none"> • Improper or stale fuel (fuel quality is poor). 	<ul style="list-style-type: none"> • Replace fuel and the fuel filter.
	<ul style="list-style-type: none"> • Air cleaner clogged. 	<ul style="list-style-type: none"> • Clean or replace the air cleaner.
Exhaust fumes are colored (black, dark or gray).	<ul style="list-style-type: none"> • Overload. 	<ul style="list-style-type: none"> • Reduce load.
	<ul style="list-style-type: none"> • Low grade fuel used. 	<ul style="list-style-type: none"> • Use specified fuel.
	<ul style="list-style-type: none"> • Fuel filter clogged. 	<ul style="list-style-type: none"> • Replace the fuel filter.
	<ul style="list-style-type: none"> • Air cleaner clogged. 	<ul style="list-style-type: none"> • Clean or replace the air cleaner paper element.
	<ul style="list-style-type: none"> • Choke not fully opened. 	<ul style="list-style-type: none"> • Check the choke position.
Exhaust fumes are colored (white or blue).	<ul style="list-style-type: none"> • Excessive engine oil. 	<ul style="list-style-type: none"> • Reduce to the specified oil level.
	<ul style="list-style-type: none"> • Piston ring worn or stuck. 	<ul style="list-style-type: none"> • See your Kubota Dealer.
Engine overheats.	<ul style="list-style-type: none"> • Engine overloaded. 	<ul style="list-style-type: none"> • Lower speed or reduce load.
	<ul style="list-style-type: none"> • Engine oil insufficient. 	<ul style="list-style-type: none"> • Fill engine oil.
	<ul style="list-style-type: none"> • The engine air intake screen and cooling fins are dirty. 	<ul style="list-style-type: none"> • Clean the air intake screen and cooling fins.
	<ul style="list-style-type: none"> • Air cleaner paper element plugged. 	<ul style="list-style-type: none"> • Clean or replace the air cleaner paper element.
	<ul style="list-style-type: none"> • Engine speed too low. 	<ul style="list-style-type: none"> • Operate at "FAST" speed.
	<ul style="list-style-type: none"> • Operating ground speed too fast. 	<ul style="list-style-type: none"> • Operate the machine at slower ground speed.
The engine knocks.	<ul style="list-style-type: none"> • Stale or low octane fuel. 	<ul style="list-style-type: none"> • Use specified fuel.
	<ul style="list-style-type: none"> • Engine overloaded. 	<ul style="list-style-type: none"> • Lower ground speed or reduce load.
	<ul style="list-style-type: none"> • Engine speed too low. 	<ul style="list-style-type: none"> • Operate at "FAST" speed.
The engine will not idle.	<ul style="list-style-type: none"> • Spark plug damaged. 	<ul style="list-style-type: none"> • Adjust the spark plug gap or replace it.
	<ul style="list-style-type: none"> • Faulty spark plug. 	<ul style="list-style-type: none"> • Replace the spark plug.
	<ul style="list-style-type: none"> • Carburetion problem. 	<ul style="list-style-type: none"> • See your Kubota Dealer.

If you have any questions, contact your local Kubota Dealer.

BATTERY TROUBLESHOOTING

Symptom (if)	Cause	Remedy	Preventive measure
The starter does not function.	• Battery overuse, dim lights.	• Charge the battery sufficiently.	• Charge the battery properly.
	• The battery has not been recharged.		
	• Poor terminal connection.	• Clean the terminal and tighten securely.	• Keep the terminal clean and tight. Apply grease and treat with anti-corrosives.
	• The battery life has expired.	• Replace the battery.	
The starter does not function from the beginning, and lights soon become dim.	• Insufficient charging.	• Charge the battery sufficiently.	• The battery must be serviced properly before initial use.
When viewed from top, the top of plates look whitish.	• Battery was used too much without recharging.	• Charge battery sufficiently.	• Charge the battery properly.
Recharging is impossible.	• The battery life has expired.	• Replace the battery.	
Terminals are severely corroded and heated up.	• Poor terminal connection.	• Clean the terminal and tighten securely.	• Keep the terminal clean and tight. Apply grease and treat with anti-corrosives.
The battery electrolyte level drops rapidly.	• There is a crack or pin holes in the electrolytic cells.	• Replace the battery.	
	• Charging system trouble.	• Contact your local Kubota Dealer.	

If you have any questions, contact your local Kubota Dealer.

MACHINE TROUBLESHOOTING

Symptom (if)	Cause	Remedy
The machine operation is not smooth.	• The hydrostatic transaxle fluid is insufficient.	• Contact your local Kubota Dealer.
	• The filter is clogged.	• Contact your local Kubota Dealer.
The machine does not move while the engine is running.	• The parking brake is on.	• Release the parking brake.
	• HST bypass engaged.	• Disengage HST bypass.
The machine moves when the motion control levers are in the "NEUTRAL LOCK" position (operating the engine).	• The hydrostatic lever linkage is not correctly adjusted.	• Ask your dealer for hydrostatic lever linkage adjustment.
	• The control linkage pivots are sticking.	• Lubricate linkage.

If you have any questions, contact your local Kubota Dealer.

MOWER TROUBLESHOOTING

Symptom (if)	Cause	Remedy
Blades do not rotate.	• Poor connection of the hour meter connector.	• Check the hour meter connector.
	• Electric clutch clearance too big.	• Consult your local Kubota Dealer for this service. (Reverse the clutch brake plates.)
	• The PTO system is not normal: PTO system malfunctioning.	• Consult your local Kubota Dealer.
	• The PTO system is normal: broken mower belt.	• Replace.
Mower belt slipping.	• Weaken tension spring.	• Replace.
	• Worn mower belt.	• Replace.
	• Mower plugged.	• Unplug and clean the mower deck.
	• Debris in pulleys.	• Clean.
Discharge deflector plugged.	• Grass too wet.	• Wait for grass to dry.
	• Grass too long.	• Raise the cutting height and cut grass twice.
	• Cutting too low.	• Raise the cutting height.
	• Engine rpm too low.	• Mow at full throttle.
	• Ground speed too fast.	• Slow down.
Streaking of grass uncut.	• Ground speed too fast.	• Slow down.
	• Engine rpm too low.	• Mow at full throttle, check and reset the engine rpm.
	• Grass too long.	• Cut grass twice.
	• Blades dull or damaged.	• Replace blades or have blades sharpened.
	• Debris in mower deck.	• Clean the mower deck.
Uneven cut.	• Mower deck not level.	• Level the mower deck.
	• Ground speed too fast.	• Slow down.
	• Blades dull.	• Have blades sharpened.
	• Blades worn or damaged.	• Replace the blades.
	• Low tire inflation.	• Add air to correct pressure.
	• Anti-scalp rollers not adjusted correctly.	• Adjust the anti-scalp rollers.
	• Wheels pressure not adjusted correctly.	• Set both tire pressure to the correct pressure. (See TIRES on page 39.)
Blades scalping grass.	• Cutting height too low.	• Raise the cutting height.
	• Turning speed too fast.	• Reduce speed on turns.
	• Ridges in terrain.	• Change the mowing pattern.
	• Rough or uneven terrain.	• Adjust wheels pressure and anti-scalp rollers.
	• Anti-scalp rollers not adjusted correctly.	• Adjust wheels pressure and anti-scalp rollers.
	• Bent blade(s).	• Replace blade(s).
Excessive vibration.	• Debris on mower deck or in pulleys.	• Clean the mower deck and pulleys.
	• Damaged mower belt.	• Replace the mower belt.
	• Damaged pulleys or bearings.	• Replace pulleys or bearings.
	• Pulleys out of alignment.	• Check pulleys.

(Continued)

TROUBLESHOOTING

Symptom (if)	Cause	Remedy
Excessive vibration.	<ul style="list-style-type: none">• Blades out of balance.	<ul style="list-style-type: none">• Have blades balanced.
Mower loads down machine.	<ul style="list-style-type: none">• Engine rpm too low.	<ul style="list-style-type: none">• Mow at full throttle, check and reset the engine rpm.
	<ul style="list-style-type: none">• Ground speed too fast.	<ul style="list-style-type: none">• Slow down.
	<ul style="list-style-type: none">• Debris wrapped around mower spindles.	<ul style="list-style-type: none">• Clean the mower.
	<ul style="list-style-type: none">• Front of deck too low.	<ul style="list-style-type: none">• Adjust the mower deck. (See MOWER DECK LEVEL on page 59.)

If you have any questions, contact your local Kubota Dealer.

INDEX

A

accessory electrical outlet.....	35
air cleaner paper element	
cleaning.....	49
replacing.....	53
anti-scalp rollers	
adjusting.....	59

B

battery	
charging.....	51
checking condition.....	51
checking the battery condition.....	54
checking voltage.....	51
jump starting.....	27
non-accessible maintenance-free type.....	51
storing.....	52
troubleshooting.....	66
blades	
checking.....	56
replacing.....	56
burnishing PTO clutch.....	30

C

choke cable	
adjusting.....	52
choke knob	
operating.....	25
cold weather	
starting engine.....	27
combustion chamber	
cleaning.....	54
cutting height	
adjusting.....	36

D

daily check	
checking fuel level	44
checking movable parts.....	46
checking the air intake screen.....	45
checking the engine oil level.....	44
checking the tire pressure.....	39,46
checking the tire pressure (warning information)..	45
cleaning the air intake screen.....	45
refueling.....	44
daily check list.....	43
dealer service.....	15

E

electric clutch	
adjusting.....	57

engine	
jump starting.....	27
operating (warning information).....	24
starting.....	24
starting in cold weather.....	27
starting information.....	26
stopping.....	26
stopping immediately.....	26
troubleshooting.....	64
warming up.....	27
engine cooling system	
cleaning.....	49
engine oil	
changing.....	48,55
engine oil filter	
replacing.....	52
engine start system	
checking.....	46

F

front caster wheels	
installing.....	40
removing.....	39
fuel.....	42
fuel filter	
checking.....	50
fuel gauge.....	26
fuel lines	
checking.....	54
replacing.....	55
fuses	
replacing.....	55

H

hand controls.....	20
hour meter.....	27
HST neutral position	
adjustment.....	58
hydrostatic transaxle bypass rods.....	34

I

instrument panel.....	20
-----------------------	----

K

key switch.....	26
-----------------	----

L

lubricants.....	42
-----------------	----

M

machine	
before operating.....	5
getting off.....	24
getting on.....	24
operating on slopes.....	7
parking.....	34
removing from storage.....	63
scrapping.....	16
servicing.....	8
specification table.....	17
starting.....	30,38
starting to operate.....	6
stopping.....	7,33
storing.....	9,63
transporting.....	8,34
troubleshooting.....	66
warranty.....	15
working.....	6

machine (new)	
changing lubricating oil.....	29
operating.....	29
operating warning.....	29

motion control lever.....	31
adjusting (warning information).....	58
adjusting maximum speed (forward).....	58
adjustment.....	33
aligning.....	58
alignment.....	58
checking the alignment.....	58
operating position.....	32
stop position.....	32

mower	
adjusting.....	23
operating.....	37
troubleshooting.....	67
type.....	21

mower belt	
replacing.....	57

mower deck	
adjusting the level (front-to-rear).....	60
adjusting the level (side-to-side).....	60
checking the level (front-to-rear).....	60
checking the level (side-to-side).....	59
cleaning.....	56
dismounting.....	23
front-to-rear leveling.....	60
mounting.....	22
side-to-side leveling.....	59

mower lift pedal.....	31
-----------------------	----

mowing tips.....	36
------------------	----

muffler	
checking.....	47,55

O

OPC system	
checking.....	47

operator's seat.....	30
lowering.....	43
raising.....	43

P

parking brake	
applying.....	24
releasing.....	24
parking brake lever.....	31
PTO switch.....	38

R

rear wheel	
installing.....	39

S

safety	
before operating the machine.....	5
general information.....	5
operating on slopes.....	7
ROPS.....	6
servicing the machine.....	8
starting to operate the machine.....	6
stopping the machine.....	7
storing the machine.....	9
transporting the machine.....	8
working the machine.....	6
safety for children.....	7
safety for operators (age 60 years and older).....	7
safety labels.....	10
care.....	14
seat belt.....	31
service intervals.....	41
spark arrester (if equipped)	
checking.....	47,55
spark plug	
checking.....	50
switches.....	20

T

terms of use.....	19
throttle cable	
adjusting.....	52
throttle lever.....	31
operating.....	25
torque tightening general specification.....	62
transmission oil	
warming up in the low temperature range.....	27

V

valve seats and clearance	
checking.....	54

W

warranty..... 15