



Kubota®

# SCL1000 | STAND-ON COMPACT LOADER AND ATTACHMENTS



# SCL1000: EXCLUSIVE FEATURES

Compact in size, packed with performance and features, Kubota's Stand-on Compact Loader conquers the toughest of tasks yet is nimble enough to get in tight spaces.



## EXCLUSIVE

### 24.8 HP TURBO CHARGED ENGINE

- No DPF
- High altitude performance
- Quiet operation



## EXCLUSIVE

### LCD COLOR DASH MONITORING SYSTEM

- Keyless start with passcode protection
- Easy to read consolidated machine monitoring
- Service interval reminders
- Easy to read in sunlight



## EXCLUSIVE

### NARROW 36" OVERALL WIDTH

- 9.8" wide track standard
- Low 4.0 psi ground pressure
- Outstanding traction force



## EXCLUSIVE

### INTEGRATED TRACK DESIGN

- Robust undercarriage welded to main frame
- Grease track tension design
- Sealed oil bath rollers

# SCL 1000





## KEY FEATURES

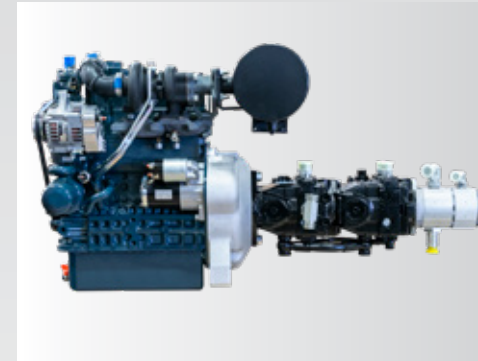

- » 24.8 HP Turbo-charged Kubota engine provides quiet operation, high altitude performance and requires no DPF.
- » Hydraulic pump directly connected to the engine reduces maintenance.



- » Vertical lift loader arms reach higher and further than the competition with a hinge pin height of 84.7" and a reach of 26" (at 45° dump angle).



- » 1000 lbs. ROC combined with 15 gpm auxiliary hydraulic flow make for a powerful and productive compact utility loader.



- » Fits in tight areas while still minimizing damage to grass or landscaping with its low-impact (4.0 psi) wide track design.
- » 4.9 mph Best in class travel speed



## KEY FEATURES



- » The patented T-drive handle provides intuitive and ergonomic steering.
- » Hydraulic pilot-operated loader and drive control valves offer precise and responsive control of the machine.



- » Right hand joystick controls loader arm and bucket movement.
- » Auxiliary hydraulics are easily operated without removing your hand from the loader joystick.
- » Continuous flow in either direction is as simple as pushing a button.



## KEY FEATURES



- » Auxiliary hydraulic lines are routed inside the loader arm for optimal protection. Case drain is standard. Auxiliary hydraulic couplers are pressure release type.
- » Attachment hose guide is standard.



- » Welded track frame has angled top for debris shedding and the dual flange front idler provides better stability and weight distribution.

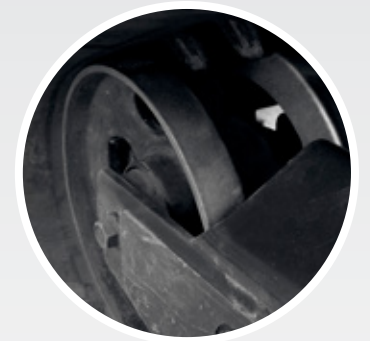

- » Engine RPM has to be at idle to unlock the hydraulics for machine operation.
- » Walk-behind mode for loading onto a trailer allows operation of the travel and loader joysticks only.



- » When operator leaves the platform, the parking brake is automatically engaged.
- » Front LED work light has 30 second courtesy timer to stay on after powering off.





## KEY FEATURES



- >> Cushioned loader boom cylinders and adjustable platform suspension increase operator comfort for maximum productivity.



- >> 4.3" Color LCD monitor
- >> Keyless start with passcode protection
- >> 12 Volt charging port

## KEY FEATURES



- >> Heavy-duty cast CII coupler and protective cover for bucket cylinder fittings.
- >> CII coupler is standard.
- >> Optional welded 2-lever style coupler.



- >> Solid state controller minimizes fuses reducing electrical components, while improving reliability.
- >> The hood is made out of impact resistant material for greater protection.



- >> Easy-to-access centralized filters and everyday maintenance items.
- >> Dash indicator light alerts when the air filter needs cleaned, and service information is readily available at the touch of a button.



- >> Maintenance time is reduced with permanently sealed and lubricated track rollers, and with the grease type track tension system.





## PERFORMANCE MATCHED

Land Pride's relationship with Kubota allows our products to be Performance Matched to your power unit by Kubota and Land Pride Engineering. The process ensures you that the hydraulic requirements, weight, and width of your attachment matches your power unit's exact specifications.

Visit [landpride.com](http://landpride.com)



## GRAPPLES

### CGC10 Compact Series

- 40" Wide
- 5/16" Tine thickness
- AR400 Steel

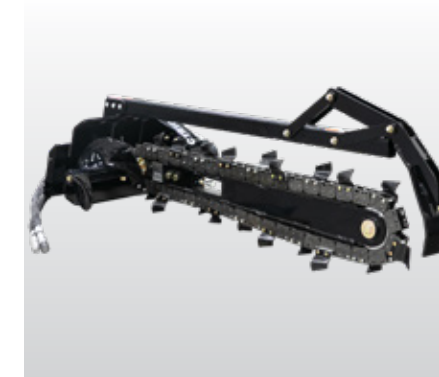

## TRENCHERS

### CTR10 Compact Series

- 30", 36", 48" Trenching depths
- 2 Motors; high speed or high torque
- Positive manual chain tensioner
- Heavy-duty hitch plate
- Chain widths: 30/36: 4", 6", 8" & 10"; 48: 4" & 6"
- 3 Chain styles



## BREAKERS

### Compact Mount for Breakers

- CII hitch
- Compatible with KXB460QA and KXB360QA Breakers
- Fully welded steel construction



## PALLET FORK

### CPF12 Compact Series

- 36" & 42" Fork lengths
- 1,200 lb. Capacity



## SKID AUGERS

### CSA10 Compact Series

- 10-20 gpm; Pendulum mount
- 2" Hex drive
- 6"-24" Dirt augers; 6" - 12" Rock augers



## POWERED RAKE

### CSR10 Compact Series

- 48" Working width; Heavy-duty hitch
- Proven stud pattern
- Manual angling; hydraulic optional
- Center pivot allows narrow width access
- Side plates can angle

## BUCKETS

### CL136L, CL142L, CL236L, CL242L, CL148H & CL248H Buckets

- CL136L Standard 36" Bucket w/ CII hitch
  - Available w/ bare edge, bolt-on edge or bolt-on teeth
- CL142L Standard 42" Bucket w/ CII hitch
  - Available w/ bare edge, bolt-on edge or bolt-on teeth
- CL236L Standard 36" Bucket w/ two lever Quick-Attach
  - Available w/ bare edge, bolt-on edge or bolt-on teeth
- CL242L Standard 42" Bucket w/ two lever Quick-Attach
  - Available w/ bare edge, bolt-on edge or bolt-on teeth
- CL148H High Capacity 48" Bucket w/ CII hitch
  - Available w/ bare edge, bolt-on edge or bolt-on teeth
- CL248H High Capacity 48" Bucket w/ two lever Quick-Attach
  - Available w/ bare edge, bolt-on edge or bolt-on teeth



# SCL1000 STAND-ON COMPACT LOADER

ENGINE	
Engine Type	Water cooled 4 cycle diesel engine with 3 cylinder, turbo, EPA Tier 4
Model Name	KUBOTA D902-T
Total Displacement	54.8 cu.in. (898 cm3)
Engine Power - SAE J1995 Gross	24.8 HP (18.5 kW/rpm)
Rated Speed	2800 rpm
Low Idling Speed	1250 rpm
DIMENSIONS	
Overall Length - Transport (w/Std Bucket Parallel to Ground)	107.7" (2.74 m)
Overall Length (w/o Bucket)	84.9" (2.16 m)
Overall Height	55.7" (1.41 m)
Overall Width w/Std Bucket	36" (91.44 cm)
Operating Weight (w/o Operator) lbs	3,035 (1,376 kg)
Rated Operating Capacity (35%)	1,000 lb (453 kg) ROC
Tipping Load	2,857 lbs (1296 kg)
Wheelbase	40.5" (1.03 m)
Hinge Pin Height at Max. Lift	84.7" (2.15 m)
Reach at Max. Lift and 45° Dump	26" (66 cm)
Track Width	9.8" (24.9 cm)
Ground Clearance	7.4" (18.8 cm)
Angle of Departure	25.2°
PERFORMANCE	
Attachment Mounting System	CII (Common Industry Interface) or 2 Lever Quick-Attach
Travel Speed (Fwd/Rev)	4.9 mph (7.9 km/h)
Ground Pressure (with Operator)	4.0 psi, 28.0 kPa (0.28 kgf/cm2)
Battery Capacity	12V, RC 80, 540 CCA
Auxiliary Hydraulic Flow	15 gal/min (56.7812 L/min)
Auxiliary Hydraulic Pressure	2800 psi (19.3 mPa) (196.8 kgf/cm2)
SERVICE & FILL CAPACITIES	
Fuel Tank Capacity	7.75 gal (29.3 L)
Hydraulic System	6 gal (22.7 L)

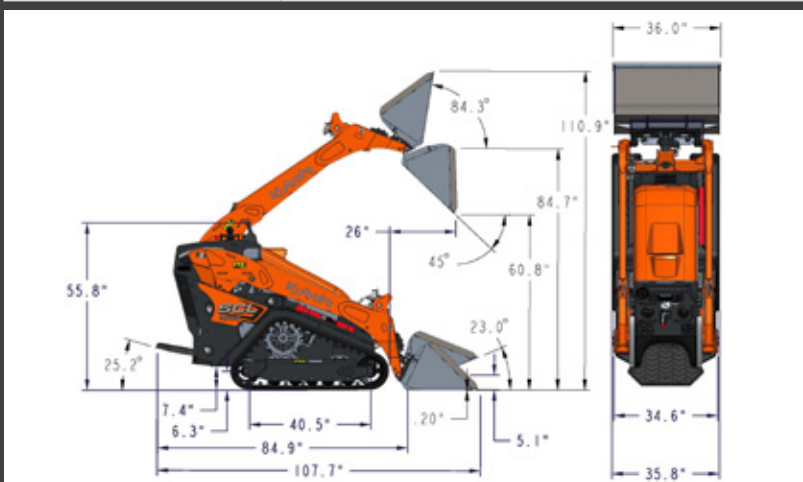

Kubota.ca

© 2024 Kubota Canada LTD

Kubota Canada Ltd reserves the right to change the stated specifications without notice. The comparisons are for descriptive purposes only and does not provide any express or implied warranty of any nature, including any warranty of merchantability or for a particular purpose. For complete operational information, the operator's manual should be consulted. Kubota Canada Ltd supplies products and services to Canadian residents only. For information regarding Kubota products or services outside of Canada, see Kubota Corporation's global website. 6/01/24 Part # SCLATT2024-EN