

Stand-on Compact Loader

SCL1000

72759

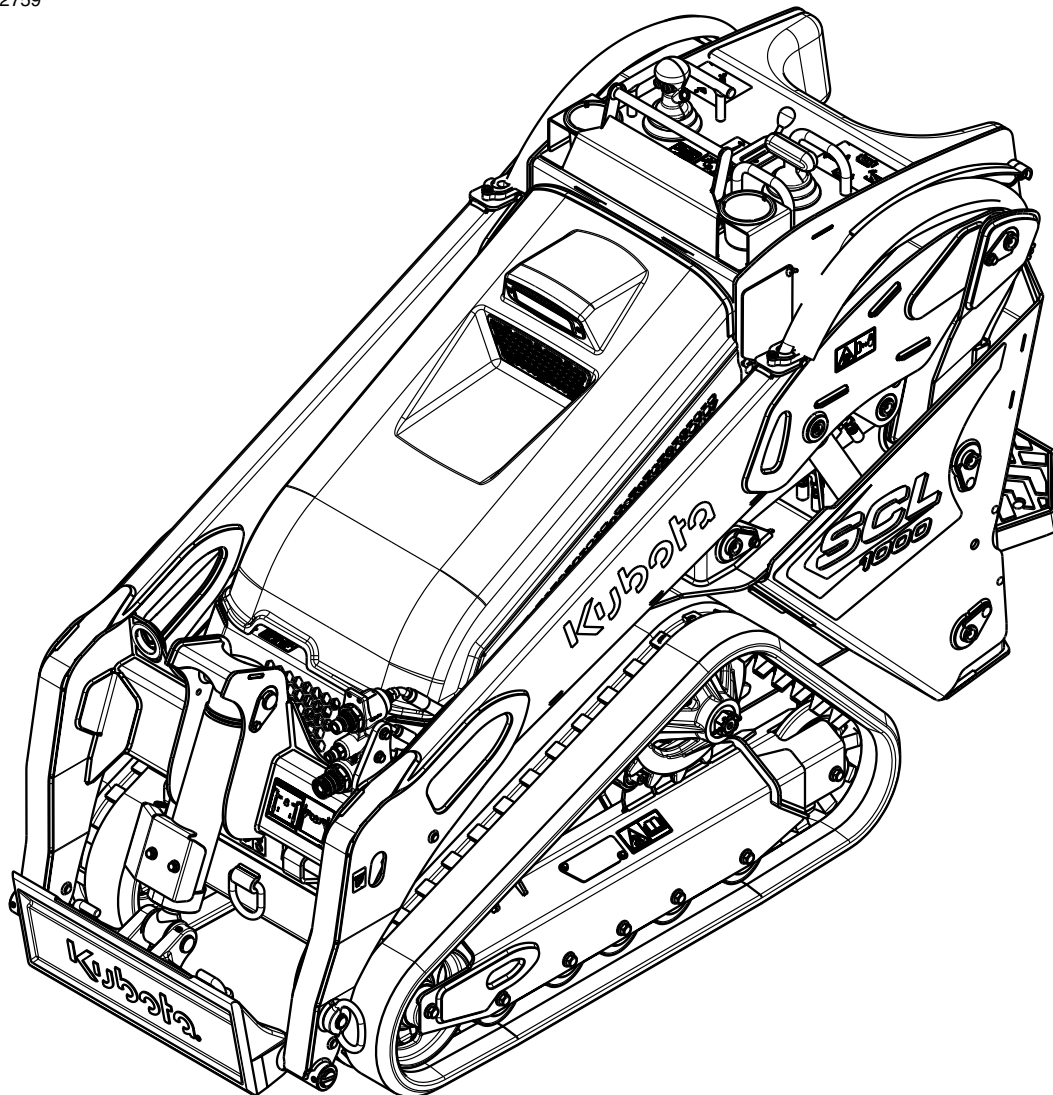

725-137MK Operator's Manual

Kubota®



Read the Operator's Manual entirely. When you see this symbol, the subsequent instructions and warnings are serious - follow without exception. Your life and the lives of others depend on it!

Cover photo may show optional equipment not supplied with standard unit.

For an Operator's Manual and Decal Kit in French Language, please see your Kubota dealer.

Machine Identification

Record your machine details in the log below. If you replace this manual, be sure to transfer this information to the new manual.

If you, or the dealer, have added Options not originally ordered with the machine, or removed Options that were originally ordered, the weights and measurements are no longer accurate for your machine. Update the record by adding the machine weight and measurements provided in the Specifications & Capacities Section of this manual with the Option(s) weight and measurements.

Model Number	
Serial Number	
Machine Height	
Machine Length	
Machine Width	
Machine Weight	
Delivery Date	
First Operation	
Accessories	<hr/> <hr/> <hr/>

Dealer Contact Information

Name: _____

Street: _____

City/State: _____

Telephone: _____

Email: _____

 California Proposition 65 WARNING: Cancer and reproductive harm - www.P65Warnings.ca.gov

Important Safety Information	1	Attachments	34
Safety at All Times	1	Connecting an Attachment	34
Look for the Safety Alert Symbol	1	Connecting to Auxiliary Hydraulics	35
Safety & Instructional Labels	6	Connecting Hydraulics	35
Safety Decals	6	Disconnecting Hydraulics	35
Instructional Decals	10	Safe Operating Practices	36
Introduction	14	Precautions While Traveling	37
Application	14	Precaution When Traveling on Inclines	38
Using This Manual	14	Parking on an Incline	38
Owner Assistance	14	Precautions for Use of Machine Near Water ...	38
Section 2: Product Overview	15	Prohibited Actions	39
Machine Parts	15	Preventing Slippage of Rubber Tracks	39
Control Panel	16	Operation Under Cold Weather	40
Section 3: Operating	17	Preparation for Operation In Cold Weather ...	40
Before You Start	17	Procedure After Completion of Work	40
Operator Presence Control	17	Section 4: Transporting	42
Operator Platform Adjustment	18	Transporting the Machine	42
Starting The Engine	18	Loading and Unloading the Machine	42
Starting With An Auxiliary Battery	18	Loading the Machine	42
Shutting Off The Engine	19	Unloading the Machine	43
SCL Shutdown Procedure	19	Lifting the Machine	44
Control Monitor Function	20	Moving Inoperable Machine	45
Splash Screen	20	Section 5: Maintenance & Lubrication	46
Passcode Screen	21	Maintenance	46
Home Screen	22	Maintenance Safety	46
Home Screen Button Functions	23	Maintenance Intervals	46
Float	24	Pre-maintenance Procedures	48
Menu Screen	25	Opening & Closing the Waist Cushion	48
Auxiliary Flow Screen	26	Opening & Closing the Control Panel	48
Service Reminders Screen	26	Opening & Closing the Hood	48
Settings Screen	27	Apply Cylinder Lock	49
Language	27	Daily Checks/Every 10 Hours	50
Software Information (Update software)	28	Checking & Adding Fuel	50
Real Time Clock (adjustable)	28	Check the Water Separator	51
Passcode Management Screen	29	Check Hydraulic Oil Level	52
Startup Passcode	29	Check Engine Oil Level	52
Change User Passcode	30	Check Coolant Level	53
Change Owner Passcode	30	Check Grease Points	53
Drive Handle Operation	32	Every 50 Hours	54
Driving the Machine	32	Check Air Cleaner Element	54
Forward and Backward	32	Check Track Tension	55
Turning	32	Every 100 Hours	56
Loader Handle Operation	33	Check Fan Belt Tension	56
Float Function	33	Change the Engine Oil	57
Auxiliary Hydraulics	33	Change the Oil Filter	58
Auxiliary Hold Mode	33	Every 200 Hours	59
		Fan Belt Adjustment	59

© Copyright 2021 All rights Reserved

Kubota provides this publication "as is" without warranty of any kind, either expressed or implied. While every precaution has been taken in the preparation of this manual, Kubota assumes no responsibility for errors or omissions. Neither is any liability assumed for damages resulting from the use of the information contained herein. Kubota reserves the right to revise and improve its products as it sees fit. This publication describes the state of this product at the time of its publication, and may not reflect the product in the future.

Kubota is a registered trademark.

All other brands and product names are trademarks or registered trademarks of their respective holders.

Printed in the United States of America.

Every 250 Hours 60
 Change Air Cleaner Element 60
 Change the Fuel Filter 61
 Change Hydraulic Return Filter 62
Every 500 Hours 63
 Change the Hydraulic Oil 63
Every 1 Year 64
 Hydraulic Tank Breather Change 64
Every 2 Years 64
 Change the Coolant 64
Long-Term Storage 66
 Periodic Replacement of Important Parts 66
Lubrication Points 70
Section 6: Specifications & Capacities 72
Section 7: Features & Benefits 74
Section 8: Troubleshooting 75
Section 9: Torque Values Chart 76
Section 10: Legal Disclaimer 77



Dealer QR Locator
The QR code on the left will link you to available dealers for Kubota products. Refer to Parts Manual QR Locator on this page for detailed instructions.

Listed below are common practices that may or may not be applicable to the products described in this manual.

Safety at All Times

Careful operation is your best assurance against an accident.

All operators, no matter how much experience they may have, should carefully read this manual and other related manuals, or have the manuals read to them, before operating the stand-on compact utility loader and attachments.

- ▲ Thoroughly read and understand the “Safety Label” section. Read all instructions noted on them.
- ▲ Do not operate the stand-on compact loader while under the influence of drugs or alcohol as they impair the ability to safely and properly operate the machine.
- ▲ Operator should be familiar with all functions of the stand-on compact loader and attachments and be able to handle emergencies quickly.
- ▲ Make sure all guards and shields appropriate for the operation are in place and secured before operating the stand-on compact loader and attachments.
- ▲ Keep all bystanders away from stand-on compact loader and work area.
- ▲ Start the stand-on compact loader from the operator platform with steering levers and hydraulic controls in neutral.
- ▲ Never dismount from a moving stand-on compact loader or leave it unattended with engine running.
- ▲ Do not allow anyone to stand between an attachment and the stand-on compact loader while hooking-up.
- ▲ Keep hands, feet, and clothing away from power-driven parts.
- ▲ While transporting and operating equipment, watch out for objects overhead and along side such as fences, trees, buildings, wires, etc.
- ▲ Store the stand-on compact loader in a safe and secure area where children normally do not play. When needed, secure attachment from falling with solid, non concrete support blocks.



Look for the Safety Alert Symbol

The SAFETY ALERT SYMBOL indicates there is a potential hazard to personal safety and extra precaution must be taken. When you see this symbol, be alert and carefully read the message that follows it. Hazard control, and accident prevention are dependent upon the awareness, concern, prudence, and proper training of personnel involved in the operation, transport, maintenance, and storage of equipment.

Be Aware of Signal Words

A signal word designates a degree or level of hazard seriousness. They are:

- ▲ **DANGER:** Indicates a hazardous situation that, if not avoided, will result in death or serious injury.
- ▲ **WARNING:** Indicates a hazardous situation that, if not avoided, could result in death or serious injury.
- ▲ **CAUTION:** Indicates a hazardous situation that, if not avoided, may result in minor or moderate injury.

Be Aware of Special Notices

Special notices are intended to point out important and helpful information that should be followed. They are usually placed inside a box. They are:

- ▲ **IMPORTANT:** Indicates that equipment or property damage could result if instructions are not followed.
- ▲ **NOTE:** Indicates supplementary explanations that will be helpful when using the equipment.

Safety Precautions for Children

Tragedy can occur if the operator is not alert to the presence of children. Children generally are attracted to stand-on compact loaders and their work.

- ▲ Never assume children will remain where you last saw them.
- ▲ Keep children out of the work area and under the watchful eye of a responsible adult.
- ▲ Be alert and shut the attachment and machine down if children enter the work area.
- ▲ Never carry children on the machine or attachment. There is not a safe place for them to ride. They may fall off and be run over or interfere with the control of the machine.
- ▲ Never allow children to operate the power machine, even under adult supervision.
- ▲ Never allow children to play on the machine or attachment.
- ▲ Use extra caution when backing up. Before the machine starts to move, look down and behind to make sure the area is clear.

Stand-on Compact Loader Shutdown And Storage

- ▲ Reduce engine speed, park on solid, level ground, disengage auxiliary hydraulics and lower attachment until it is flat on the ground or solid non concrete support blocks.
- ▲ Turn off engine and turn off the power switch to prevent unauthorized starting.
- ▲ Relieve all hydraulic pressures.
- ▲ Wait for all components to stop before leaving operator platform.
- ▲ Carefully step down from the operator platform.

Listed below are common practices that may or may not be applicable to the products described in this manual.

Dig Safe - Avoid Underground Utilities

- ▲ **USA: Call 811**
CAN: digsafecanada.ca
Always contact your local utility companies (electrical, telephone, gas, water, sewer, and others) before digging so that they may mark the location of any underground services in the area.
- ▲ Be sure to ask how close you can work to the marks they positioned.

Transport Safely

- ▲ Comply with federal, state, and local laws.
- ▲ Use towing vehicle and trailer of adequate size and capacity. Secure the stand-on compact loader to the trailer with chocks, tie downs, and chains.
- ▲ Sudden braking can cause a towed trailer to swerve unexpectedly. Reduce speed if towed trailer is not equipped with brakes.
- ▲ Avoid contact with any overhead utility lines or electrically charged conductors.
- ▲ **IMPORTANT:** Do not tow a load that is more than double the weight of the vehicle towing the load.

Operate Safely

- ▲ Always drive with load on end of loader arms low to the ground.
- ▲ Always drive straight up and down slopes with heavy end of the stand-on compact loader on the "uphill" side.
- ▲ Engage park brake when stopped on an incline.

Keep Riders Off Machinery

- ▲ Never carry riders on the stand-on compact loader or attachment.
- ▲ Riders obstruct operator's view and interfere with the control of the machine.
- ▲ Riders can be struck by objects or thrown from the machine.
- ▲ Never use stand-on compact loader or attachment to lift or transport riders.

Practice Safe Maintenance

- ▲ Understand procedure before doing work. Refer to the Operator's Manual for additional information.
- ▲ Work on a level surface in a clean dry area that is well-lit.
- ▲ Lower attachment to the ground and follow all shutdown procedures before leaving the operator platform to perform maintenance.
- ▲ Do not work under any hydraulically supported equipment. It can settle, suddenly leak down, or be lowered accidentally. If it is necessary to work under the equipment, securely support it with stands or suitable blocking beforehand.
- ▲ Use properly grounded electrical outlets and tools.
- ▲ Use correct tools and equipment for the job that are in good condition.
- ▲ Allow the machine to cool before working on it.
- ▲ Disconnect battery ground cable (-) before servicing or adjusting electrical systems or before welding on the machine.
- ▲ Inspect all parts. Make certain that parts are in good condition & installed properly.
- ▲ Replace parts on the stand-on compact loader with genuine Kubota parts only. Do not alter this machine in a way which will adversely affect its performance.
- ▲ Do not grease or oil while the machine is in operation.
- ▲ Remove buildup of grease, oil, or debris.
- ▲ Always make sure any material and waste products from the repair and maintenance of the machine are properly collected and disposed.
- ▲ Remove all tools and unused parts from the machine before operation.

These are common practices that may or may not be applicable to the products described in this manual.

Prepare for Emergencies

- ▲ Be prepared if a fire starts.
- ▲ Keep a first aid kit and fire extinguisher handy.
- ▲ Keep emergency numbers for doctor, ambulance, hospital, and fire department near phone.

Wear Personal Protective Equipment (PPE)

- ▲ Wear protective clothing and equipment appropriate for the job such as safety shoes, safety glasses, hard hat, dust mask, and ear plugs.
- ▲ Clothing should fit snug without fringes and pull strings to avoid entanglement with moving parts.
- ▲ Prolonged exposure to loud noise can cause hearing impairment or hearing loss. Wear suitable hearing protection such as earmuffs or earplugs.
- ▲ Operating a machine safely requires the operator's full attention. Avoid wearing headphones while operating equipment.

Avoid High Pressure Fluids

- ▲ Escaping fluid under pressure will penetrate the skin or eyes causing serious injury.
- ▲ Relieve all residual pressure before disconnecting hydraulic lines or performing work on the hydraulic system.
- ▲ Make sure all hydraulic fluid connections are properly tightened/torqued and all hydraulic hoses and lines are in good condition before applying pressure to the system.
- ▲ Use a piece of paper or cardboard, NOT BODY PARTS, to check for suspected leaks.
- ▲ Wear protective gloves and safety glasses or goggles when working with hydraulic systems.
- ▲ **DO NOT DELAY.** If an accident occurs, seek immediate emergency medical care or gangrene may result.

Listed below are common practices that may or may not be applicable to the products described in this manual.

Avoid crystalline Silica (quartz) Dust

Because crystalline silica is a basic component of sand and granite, many activities at construction sites produce dust containing crystalline silica. Trenching, sawing, and boring of material containing crystalline silica can produce dust containing crystalline silica particles. This dust can cause serious injury to the lungs (silicosis).

There are guidelines which should be followed if crystalline silica (quartz) is present in the dust.



- ▲ Be aware of and follow OSHA (or other local, State, or Federal) guidelines for exposure to airborne crystalline silica.
- ▲ Know the work operations where exposure to crystalline silica may occur.
- ▲ Participate in air monitoring or training programs offered by the employer.
- ▲ Be aware of and use optional equipment controls such as water sprays, local exhaust ventilation, and enclosed cabs with positive pressure air conditioning if the machine has such equipment. Otherwise respirators shall be worn.
- ▲ Where respirators are required, wear a respirator approved for protection against crystalline silica containing dust. Do not alter respirator in any way. Workers who use tight-fitting respirators can not have beards/mustaches which interfere with the respirator seal to the face.
- ▲ If possible, change into disposable or washable work clothes at the work site; shower and change into clean clothing before leaving the work site.
- ▲ Do not eat, drink, use tobacco products, or apply cosmetics in areas where there is dust containing crystalline silica.
- ▲ Store food, drink, and personal belongings away from the work area.
- ▲ Wash hands and face before eating, drinking, smoking, or applying cosmetics after leaving the exposure area.

Handle Chemicals Properly

- ▲ Protective clothing should be worn.
- ▲ Handle all chemicals with care.
- ▲ Follow instructions on container label.
- ▲ Agricultural chemicals can be dangerous. Improper use can seriously injure persons, animals, plants, soil, and property.
- ▲ Inhaling smoke from any type of chemical fire can be a serious health hazard.
- ▲ Store or dispose of unused chemicals as specified by the chemical manufacturer.



This page left blank intentionally.

Safety & Instructional Labels

Your Stand-on Compact Loader comes equipped with all safety labels in place. They are designed to help you safely operate your machine. Read and follow their directions.

1. Keep all safety labels clean and legible.
2. Refer to this section for proper label placement. Replace all damaged or missing labels. Order new labels from your nearest Kubota dealer. To find your nearest dealer, visit our dealer locator at www.kubota.com.
3. Some new equipment installed during repair requires safety labels to be affixed to the replaced component as specified by Kubota. When ordering new components make sure the correct safety labels are included in the request.

4. Refer to this section for proper label placement. To install new labels:
 - a. Clean surface area where label is to be placed.
 - b. Spray soapy water onto the cleaned area.
 - c. Peel backing from label and press label firmly onto the surface.
 - d. Squeeze out air bubbles with edge of a credit card or with a similar type of straight edge.

Safety Decals

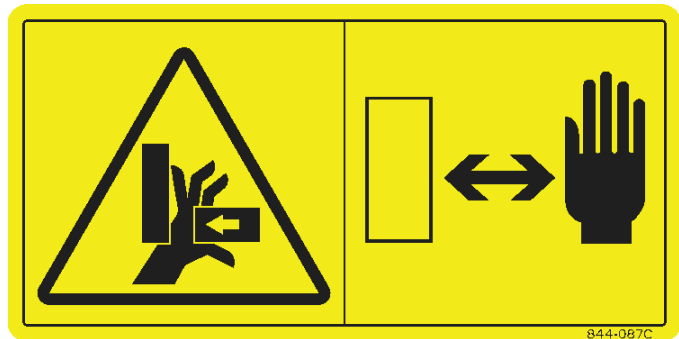
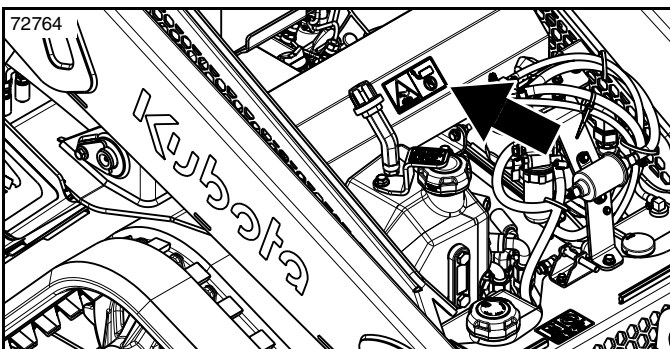
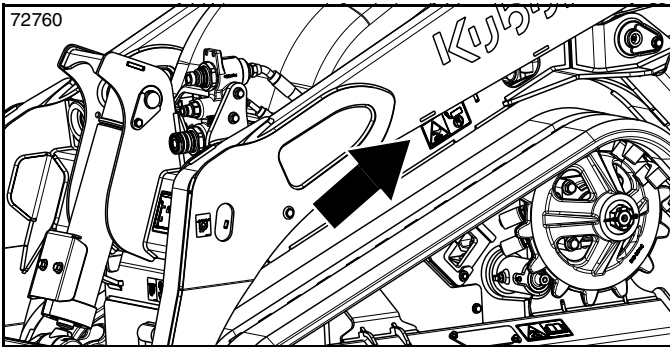
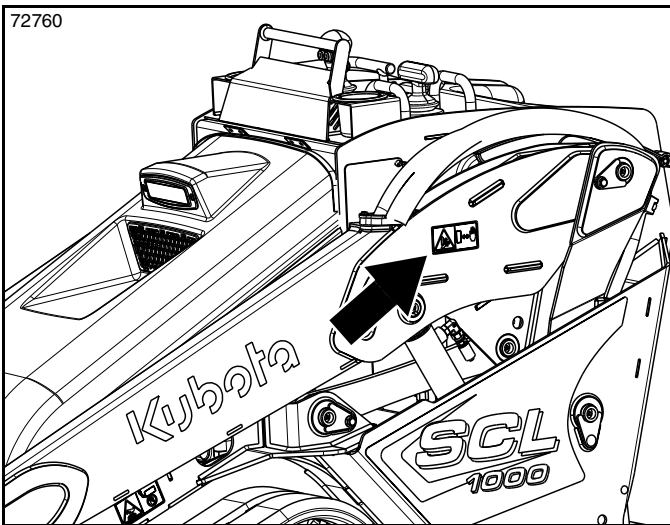

844-087C

Pinch/crush hazard. Do not allow hands within the working range.

2-Places (left and right side of machine)



844-086C

Burn hazard. Do not touch hot parts such as exhaust etc.

2-Places (1 on the left side of the machine next to the muffler pipe and 1 under the hood on the muffler heat deflector)

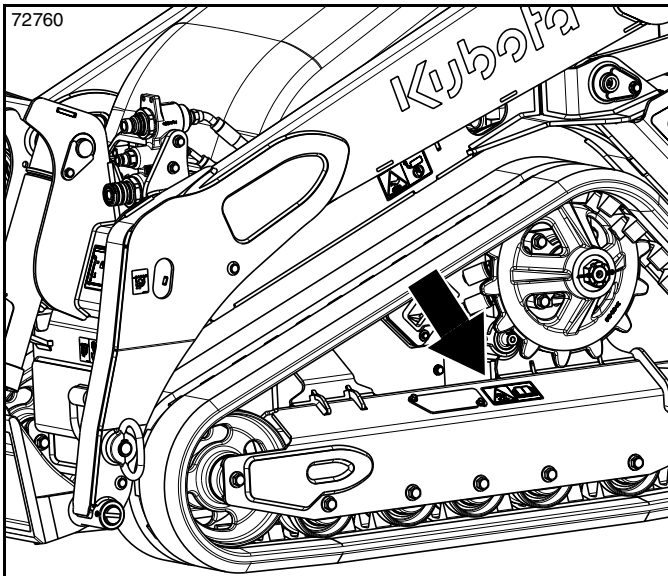

844-095C

Thrown object hazard and high pressure fluid/grease hazard. Do not loosen fittings completely or too quickly.
2-Places (left and right side of machine)

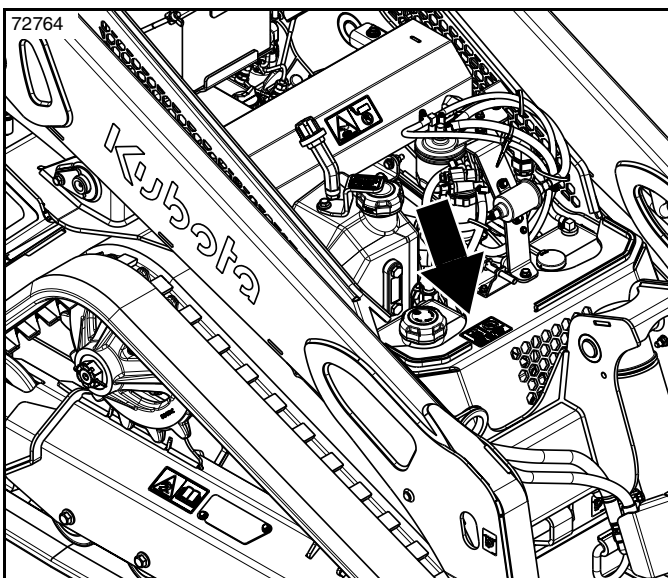

844-085C

Fire hazard. Diesel fuel only. Keep ignition sources away.

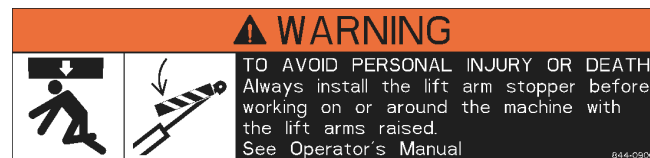
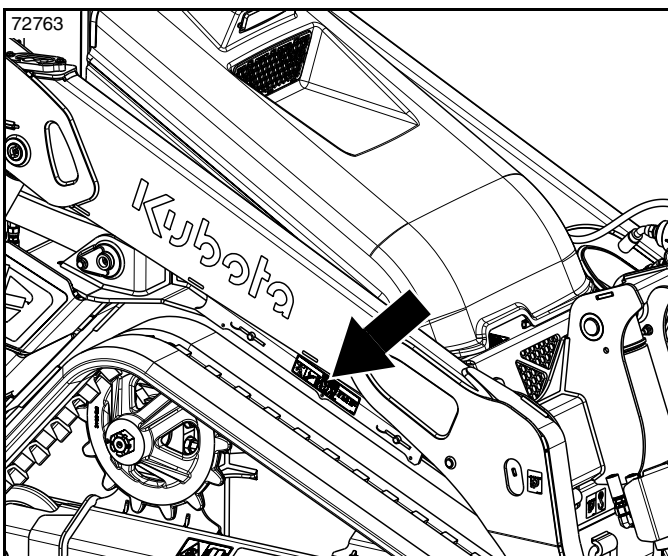

844-090C

Crushing hazard. Always use cylinder lock when working around the machine with raised arms.

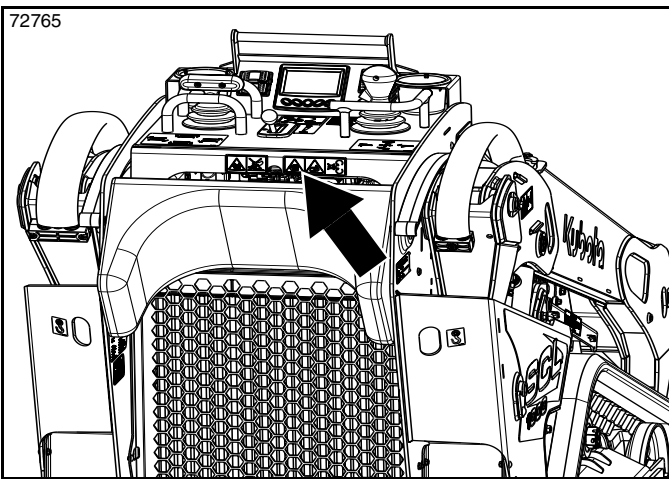
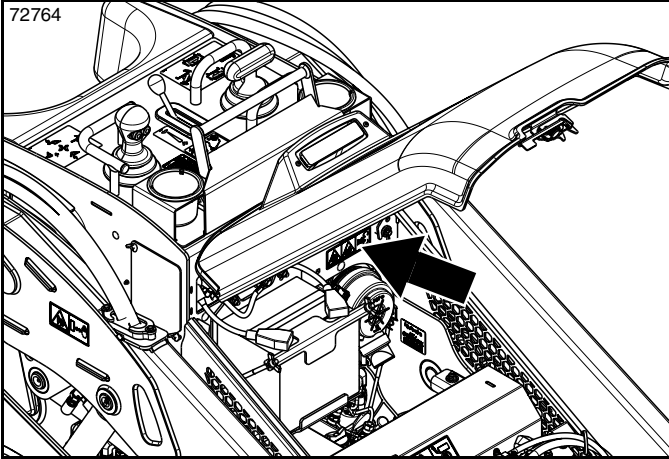

844-091C

Cutting & entanglement hazard. Keep away from fan and fan belt.

2-Places (Under the hood & behind the cushion).

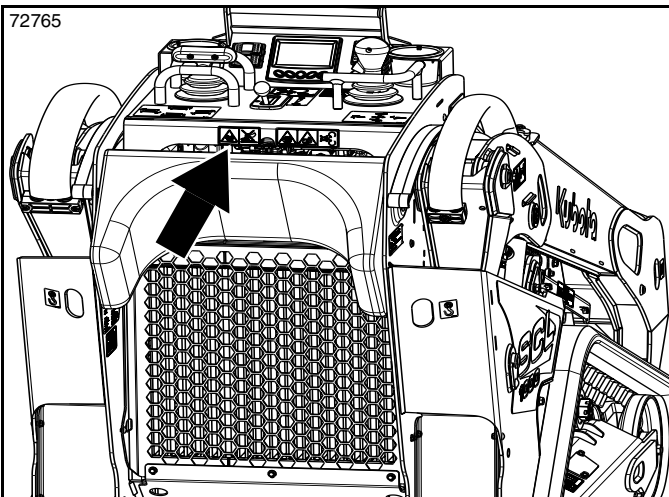

844-088C

Burn hazard. Never remove radiator cap from a hot radiator. Give time for cool down.

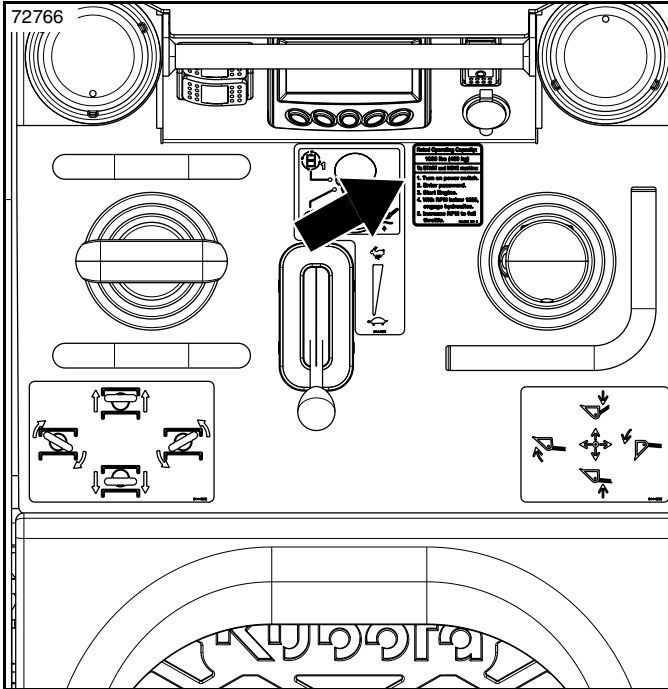

Rated Operating Capacity:
1000 lbs (460 kg)
To START and MOVE machine:
<ol style="list-style-type: none"> 1. Turn on power switch. 2. Enter password. 3. Start Engine. 4. With RPM below 1500, engage hydraulics. 5. Increase RPM to full throttle.
<small>844-192C REV B</small>

844-192C

1000 LBS (460 kg) operating capacity.

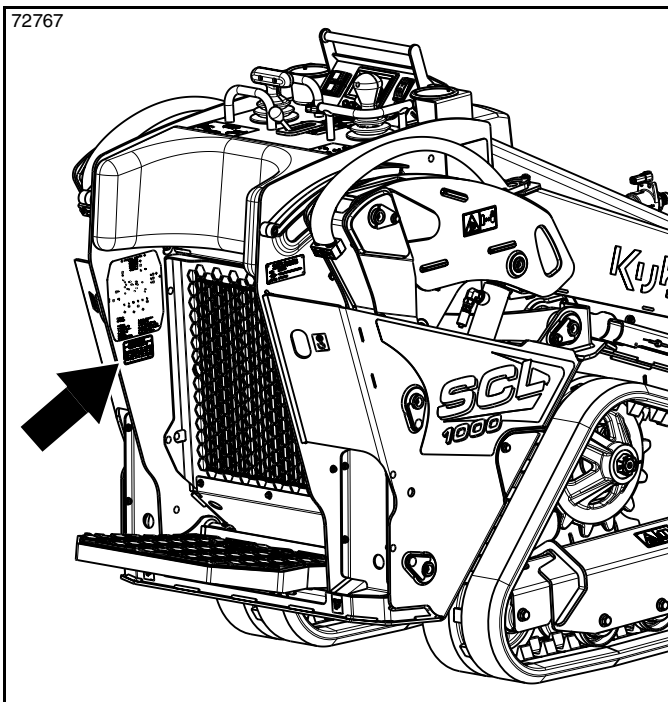

⚠ WARNING
<p>California Proposition 65</p> <p>Engine exhaust, some of its constituents, certain vehicle components and fluids, contain or emit chemicals known to the State of California to cause cancer and birth defects or other reproductive harm.</p> <p style="text-align: right;"><small>844-246C</small></p>

844-246C

California Proposition 65. Dangerous chemical hazard.

Instructional Decals

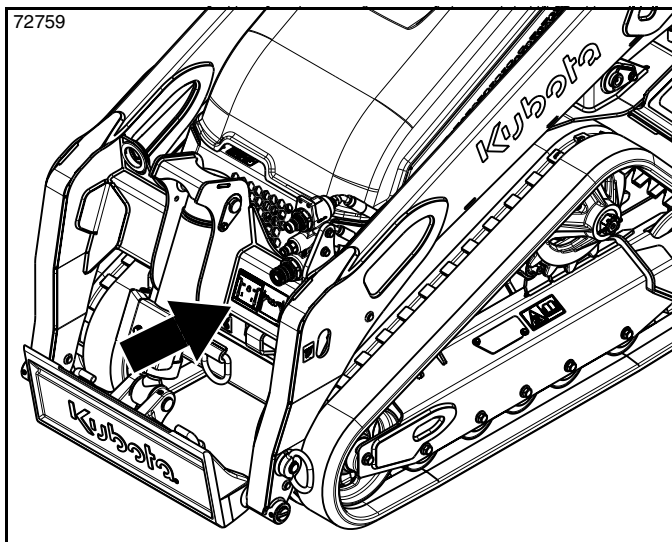
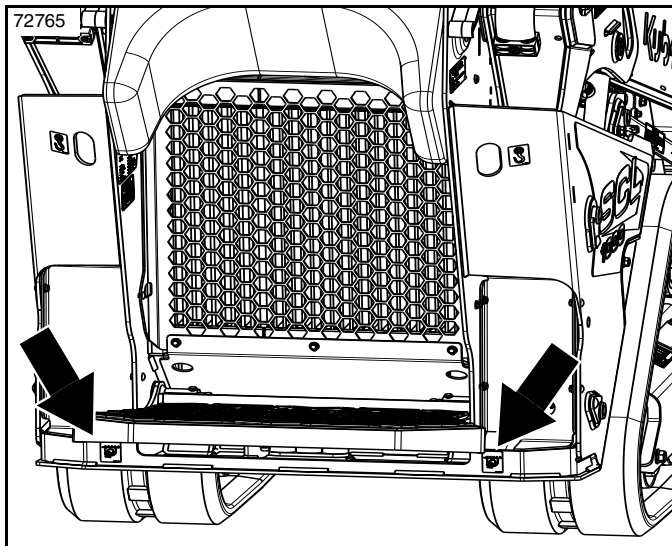
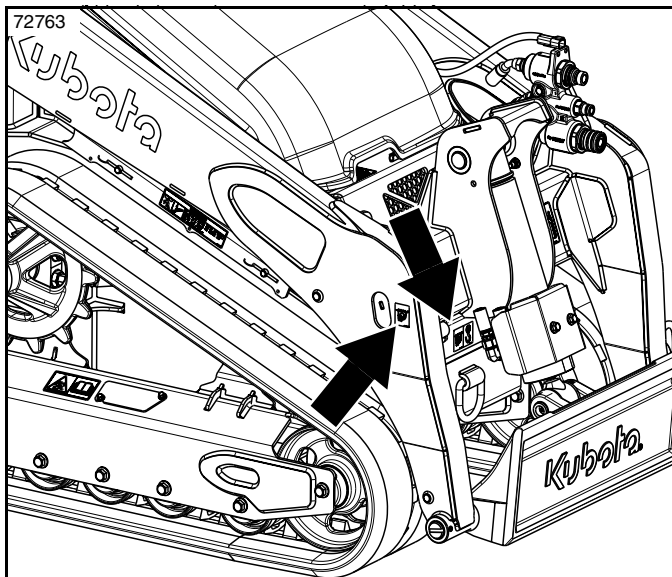

844-089C

844-089C

Tie-down points.

5-Places (1 above D ring, 1 on each side of loader arm and 1 on each side of the operator platform).

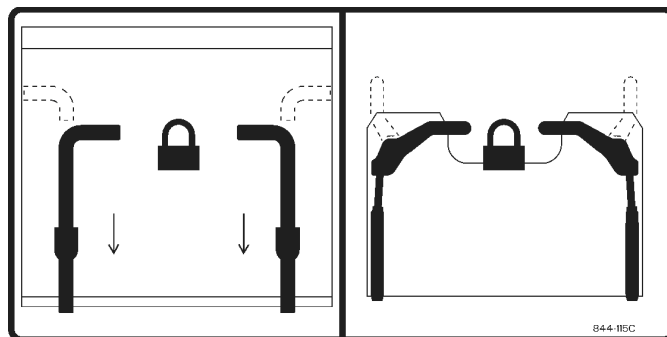

844-115C

Hitch lock instruction.

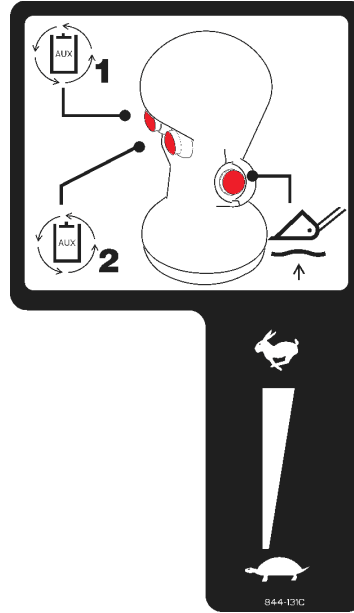
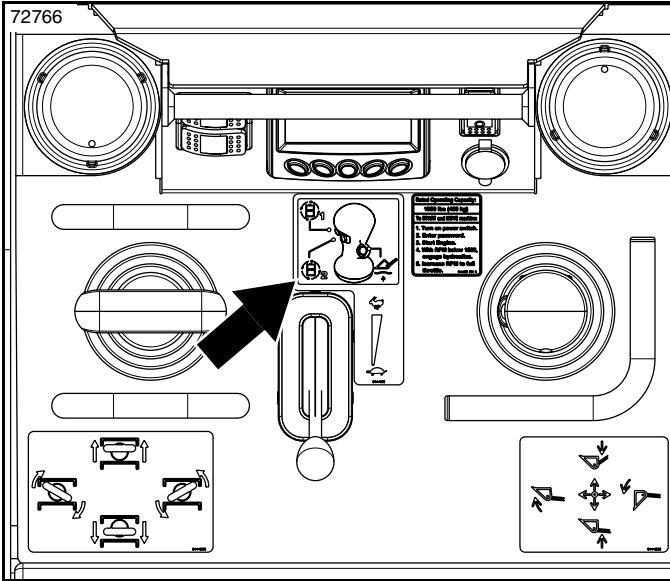

844-131C

Auxiliary hydraulic, float & throttle control instruction.

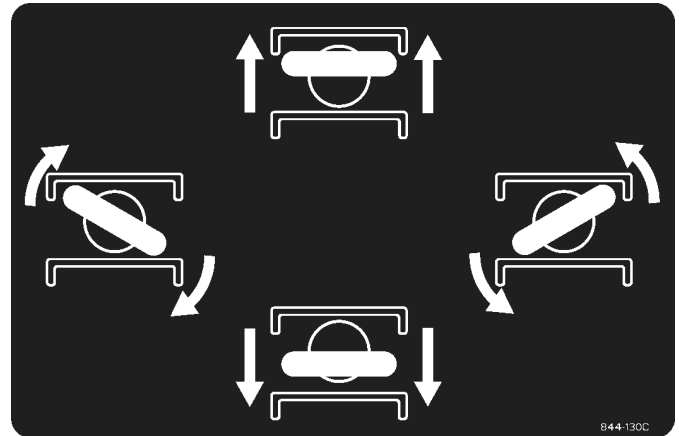
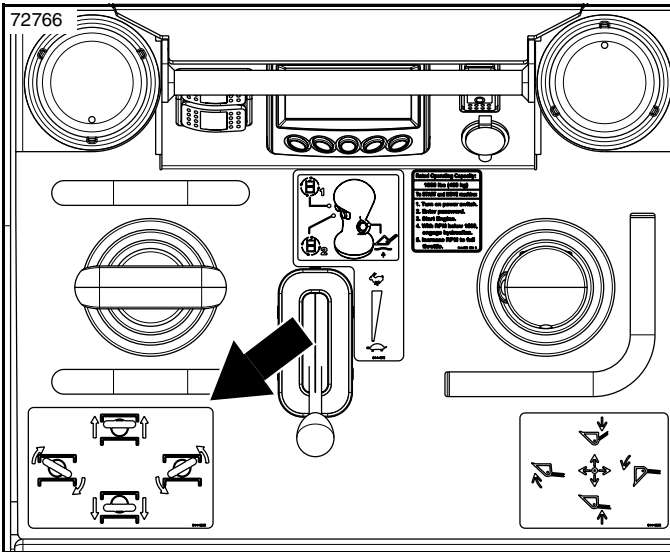

844-130C

Drive control instruction.

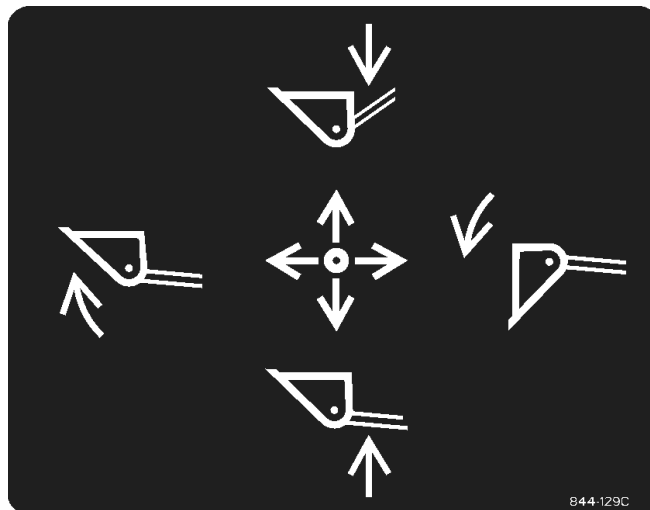
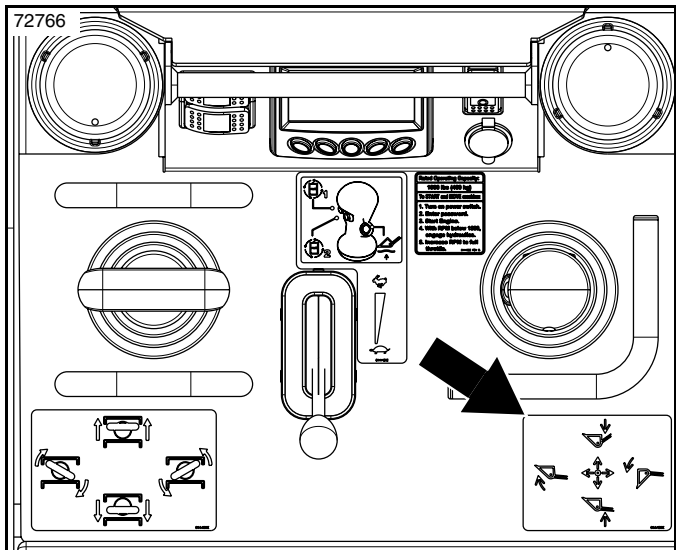

844-129C

Loader control instruction.

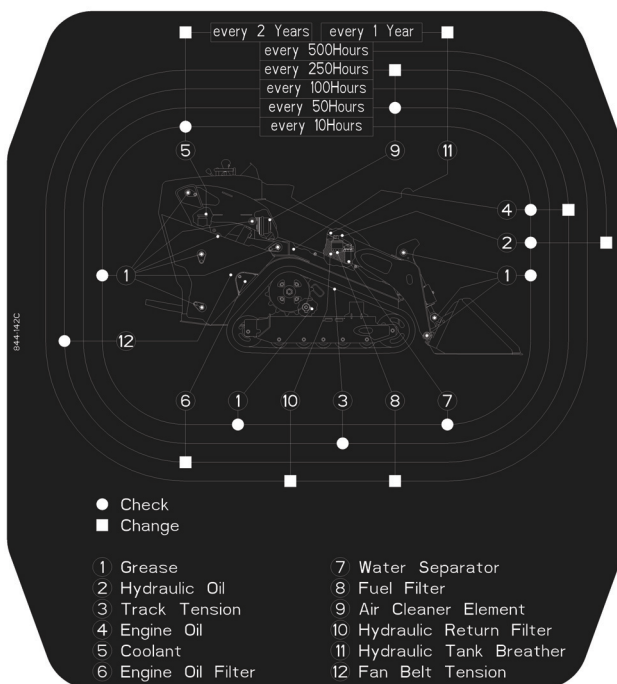
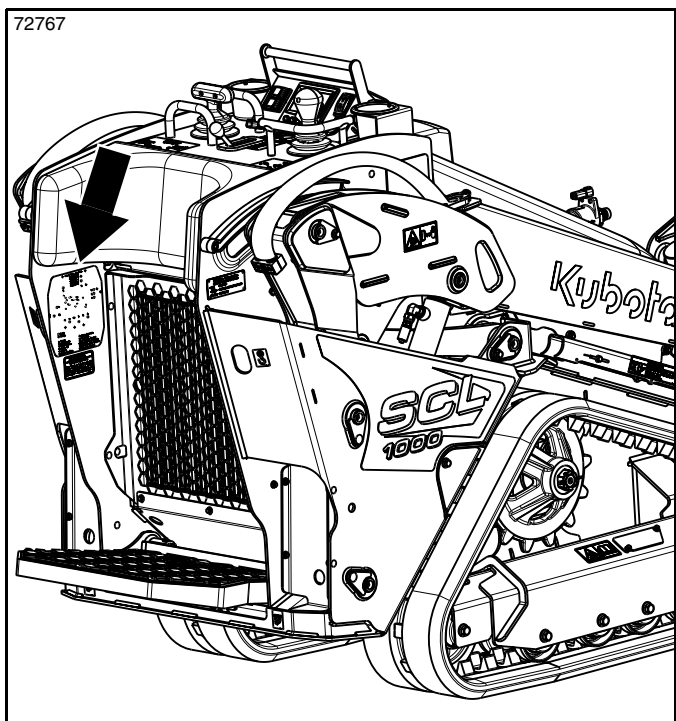

844-142C

Service interval instruction.

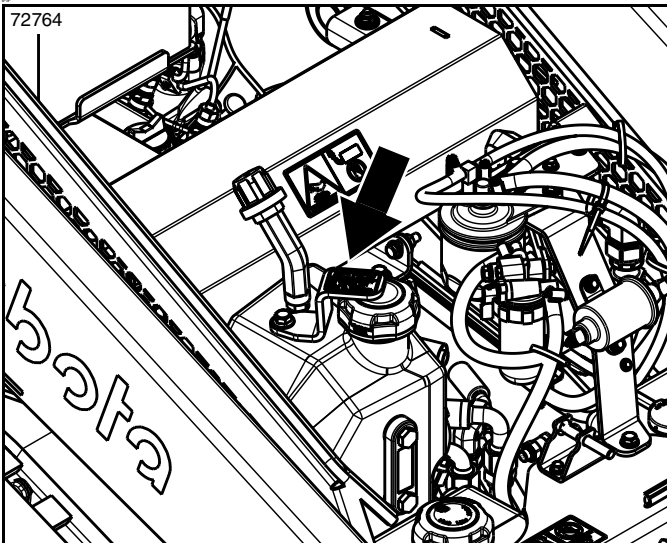
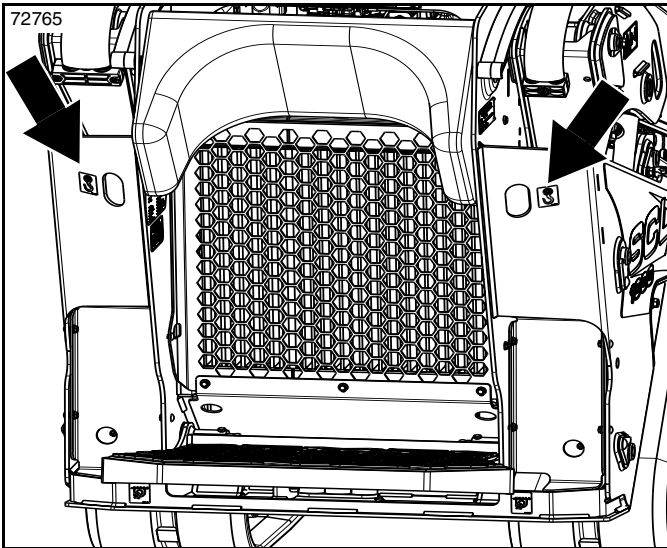
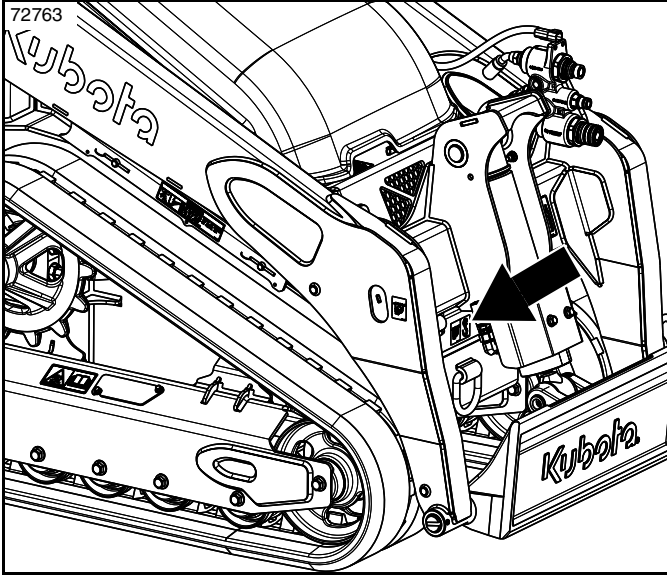

844-235C

844-235C

Lift points.

3-Places (1 above D ring and 1 on each side of the operator platform).

NOTICE

AFTER FILLING TANK
LET MACHINE IDLE
FOR ONE MINUTE
PRIOR TO OPERATION.

844-247C

Machine idle notice.

Introduction

Kubota welcomes you to the growing family of new product Owners. This stand-on compact loader has been designed with care and built by skilled workers using quality materials. Proper maintenance and safe operating practices will help you get years of satisfactory use from this machine.

Application

The Kubota SCL1000 Stand-On Compact Loader is designed for use in commercial or rental applications. The features of the SCL1000, coupled with its many attachments, will help the user quickly and effectively complete landscaping and construction tasks. Its narrow width and compact size allow the SCL1000 to complete jobs in areas that larger power units cannot reach. With the available attachments, tasks such as digging, material handling, trenching, and backfilling will be made easier while using the SCL1000.

The SCL1000 has a rated operating capacity of 1,000 lbs (454 kg), 15 gpm (57 Lpm) hydraulic flow, and less than 4 psi of ground pressure. The machine features a 24.8 hp (18.5 kW) turbo charged diesel engine, class leading speed and reach, as well as a keyless start. These features, plus many others, make this stand-on compact loader ideal for landscapers, contractors, or those who like to “do-it-yourself.”

See “**Specifications & Capacities**” on page 72 and “**Features & Benefits**” on page 74 for additional information.

NOTE: This machine has patents pending.

Using This Manual

- This Operator’s Manual is designed to help familiarize you with safety, operation, adjustments, troubleshooting and maintenance. Read this manual and follow the recommendations to help ensure safe and efficient operation.
- The information contained within this manual was current at the time of printing. Some parts may change slightly to assure you of the best performance.
- To order a new Operator’s Manual contact your authorized dealer.

Terminology

“Right” or “Left” as used in this manual is determined by the direction the operator faces while sitting looking forward in the operator’s seat unless otherwise stated.

Owner Assistance

The Online Warranty Registration should be completed by the dealer at the time of purchase. This information is necessary to provide you with quality customer service.

The parts on your machine have been specially designed by Kubota/Land Pride and should only be replaced with genuine Kubota parts. Contact a Kubota dealer if customer service or repair parts are required. Your Kubota dealer has trained personnel, repair parts, and equipment needed to service this machine.

Serial Number

For quick reference and prompt service, record model and serial number on the inside cover page and again on the warranty page. Always provide model number and serial number when ordering parts and in all correspondences with your Kubota dealer. For location of your serial number plate, see **Figure 1-1**.

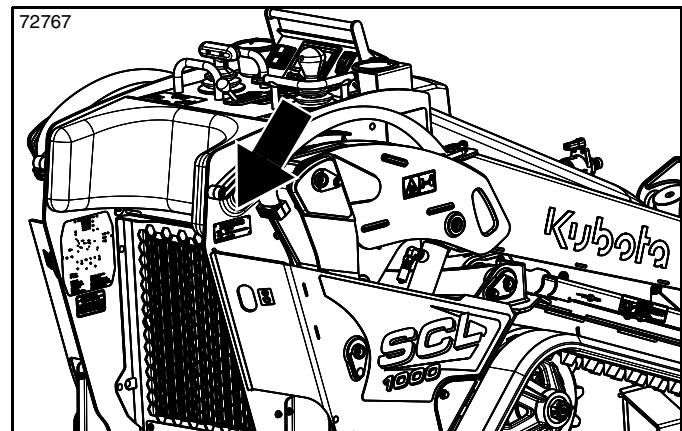

SCL Serial Number Plate
Figure 1-1

Further Assistance

Your dealer wants you to be satisfied with your new stand-on compact loader. If for any reason you do not understand any part of this manual or are not satisfied with the service received, the following actions are suggested:

1. Discuss any problems you have with your machine with your dealership service personnel so they can address the problem.
2. If you are still not satisfied, seek out the Owner or general manager of the dealership, explain the question/problem, and request assistance.

Machine Parts

Refer to Figure 2-1:

Your stand-on compact loader is designed with innovative and state-of-the-art features. Knowing their

location and how these features work will make handling your SCL1000 more comfortable. Familiarize yourself with the list of key features below.

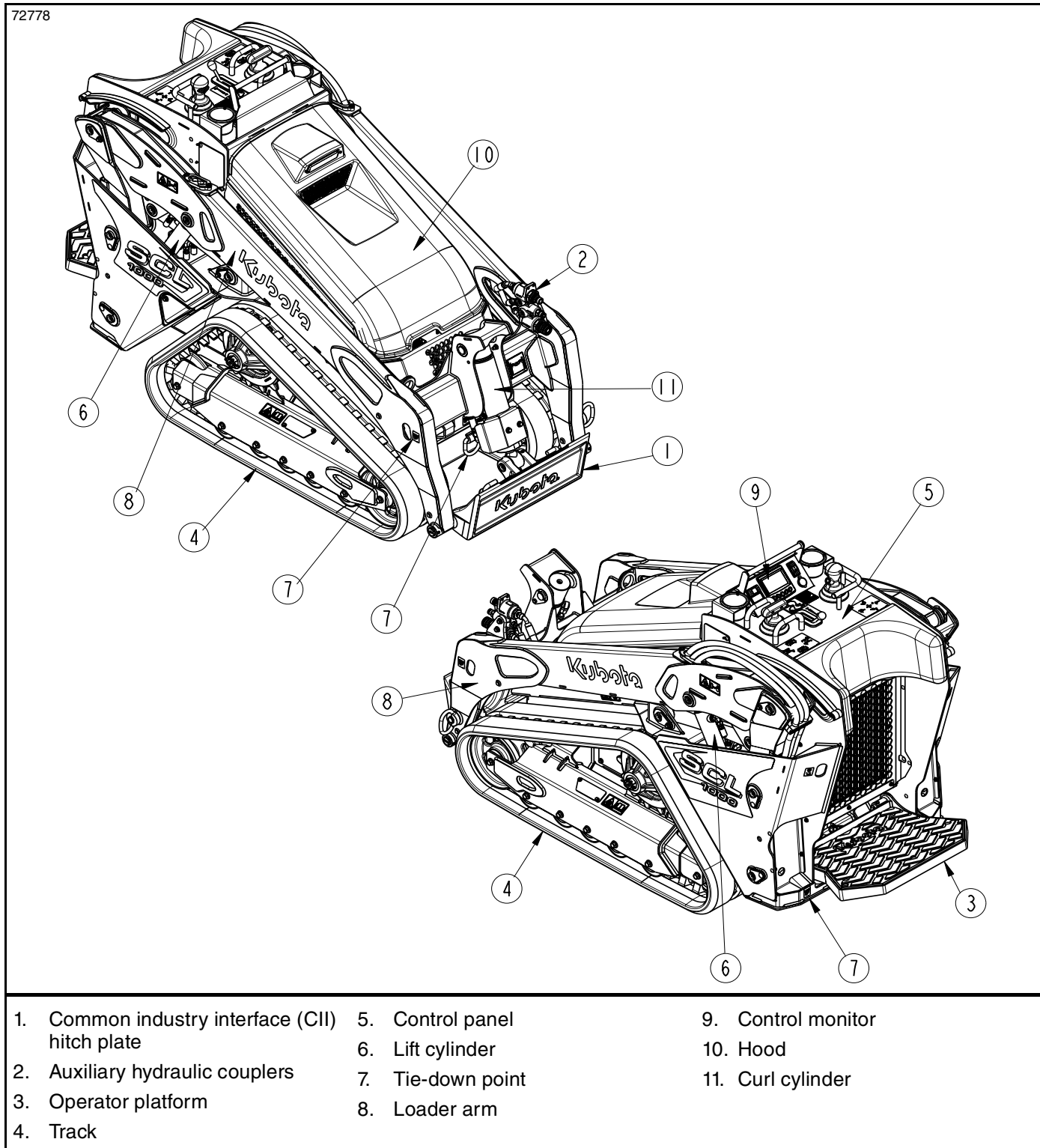

SCL1000 Features
Figure 2-1

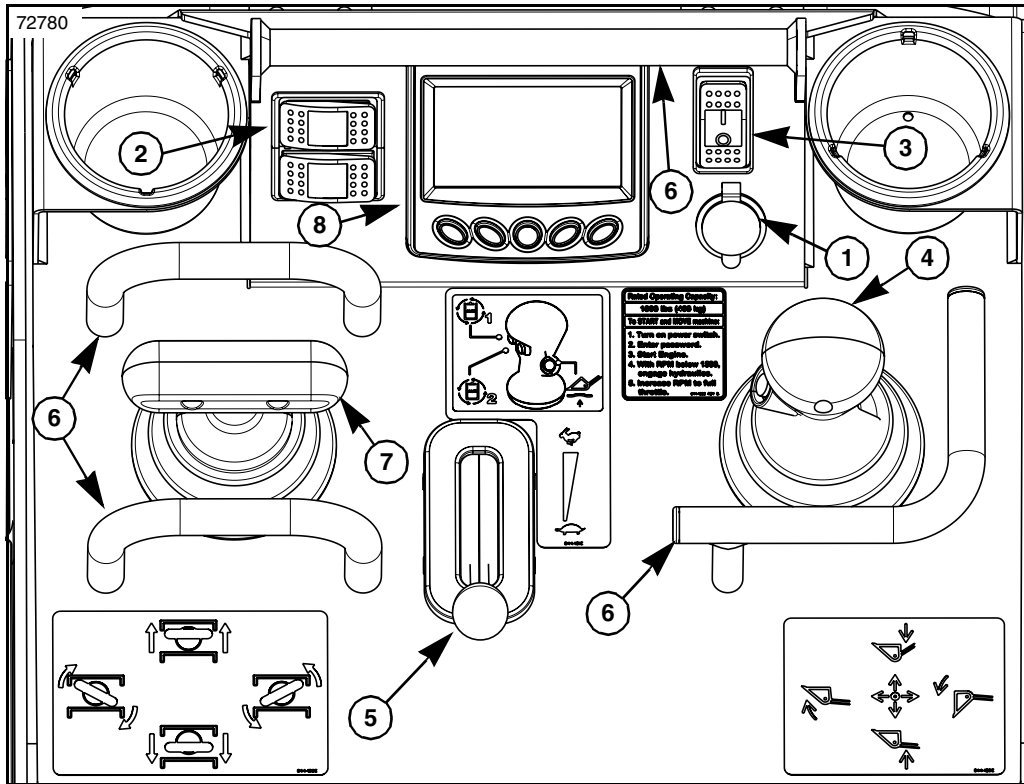

Control Panel
Figure 2-2

Control Panel

Refer to Figure 2-2:

Power plug 12V (#1)

The power plug allows the Operator to power and/or charge various electrical devices.

Emergency boom lower switch (#2)

Flip the emergency boom lower switch and press the float button on the loader control handle at the same time (See “Figure 3-29” on page 33) to slowly lower the loader arms to the ground. This switch can be used to lower the loader arms when the hydraulics are not activated. This switch functions even when the power switch is turned off.

WARNING

To avoid serious injury or death:

The loader arms may lower faster if there is a load in the bucket or if there is an attachment hooked up to the loader arms. Make certain nobody is around the loader arms when they are lowered.

Power switch (#3)

Flip the power switch on to power up the control monitor. The power switch also serves as an emergency kill-switch. When the switch is flipped off, the machine will shut down.

Loader control handle (#4)

The loader control handle operates the machine’s curl cylinder and lift cylinders. The curl cylinder tilts the bucket, or other attachment, forward and backward. The lift cylinders raise and lower the loader arms. The machine’s auxiliary hydraulics and float function are controlled by buttons on the loader control handle. See “Loader Handle Operation” on page 33 for detailed instructions.

Throttle lever (#5)

Engine speed will increase when the throttle lever is pushed forward and decrease when pulled backward.

Grip bars (#6)

Grip bars are in place on the control panel to help the Operator brace themselves in bumpy conditions.

Drive control handle (#7)

The drive control handle controls the machine’s maneuverability. See “Drive Handle Operation” on page 32 for detailed instructions.

Control monitor (#8)

The easy-to-read control monitor is passcode protected. It provides many useful functions and features that will aid in completing jobs, properly maintaining the machine and help in overall safe operation. See “Control Monitor Function” on page 20 for detailed instructions.

Section 3: Operating

Before You Start

! DANGER

To avoid serious injury or death:

- Check clearances when driving under objects such as doorways or large branches. Be aware of all overhead utility and electrical lines as well as having all underground lines marked if digging will take place.
- Make sure all guards and shields are installed and in good working condition when operating the machine.

! WARNING

To avoid serious injury or death:

- Familiarize yourself with the safe operation of the machine.
- Familiarize yourself with the machine's controls.
- Allow only persons to operate this machine who have fully read and comprehended this manual, who have been properly trained in the safe operation of this machine. Serious injury or death can result from the inability to read, understand, and follow instructions provided in this manual.
- Wear all the proper personal protective equipment for head, hands, feet, eyes and ears. This machine can produce noise loud enough to cause hearing damage when ears are exposed for extended periods unprotected.
- Check to see that the operator presence control and all shielding are in working order.
- Familiarize yourself with the job site. Be aware of any obstacles that you might encounter.
- Make sure the working area is clear of people and animals.

Hazard control and accident prevention are dependent upon awareness, concern, prudence and proper training involved in operation, transport, maintenance, and storage of the stand-on compact loader. Therefore, it is absolutely essential that no one operates the stand-on compact loader without first having read, fully understood, and become totally familiar with the Operator's Manual. Make sure the Operator has paid particular attention to:

- **Important Safety Information**, page 6
- **Section 2: Product Overview**, page 15
- **Section 3: Operating**, page 17
- **Section 5: Maintenance & Lubrication**, page 46

Perform the following Operating Checklist before operating your stand-on compact loader.

Operating Checklist

✓	Check	Ref.
	Make sure there are no hydraulic leaks on the unit. Refer to "Avoid High Pressure Fluids".	Page 3
	Check the condition of the safety labels and carefully read and follow all safety rules. Refer to "Safety Decals".	Page 6
	Make sure to get familiar with the stand-on compact loader feature parts and controls. Refer to "Section 2: Product Overview".	Page 15
	Check all control lamps, indicators and hour meter. Refer to "Control Monitor Function".	Page 16
	Read and follow all operating procedures. Refer to "Section 3: Operating".	Page 17
	Check service reminders. Refer to "Service Reminders Screen" on page 26.	Page 26
	Check the machine's fluid levels and perform all daily and scheduled maintenance and lubrications. Refer to "Section 5: Maintenance & Lubrication".	Page 46
	Check for loose hardware initially and periodically. Refer to "Section 9: Torque Values Chart".	Page 75
	Go around the machine and check for visual damage and wear.	

Operator Presence Control

Refer to Figure 3-1:

The operator presence control is in place for the safety of the Operator and anyone in the surrounding area. It should be maintained in good working condition. Do not operate the machine if the operator presence control is not functioning properly.

Located under the operator platform, the operator presence control detects when the Operator is present on the operator platform. The operator presence control must detect an Operator in order to activate the hydraulics, drive the machine or operate the loader. All hydraulically powered functions will stop when the operator presence control does not detect an Operator. The operator presence control can be temporarily overridden. The temporary override procedure can be found on page 24.

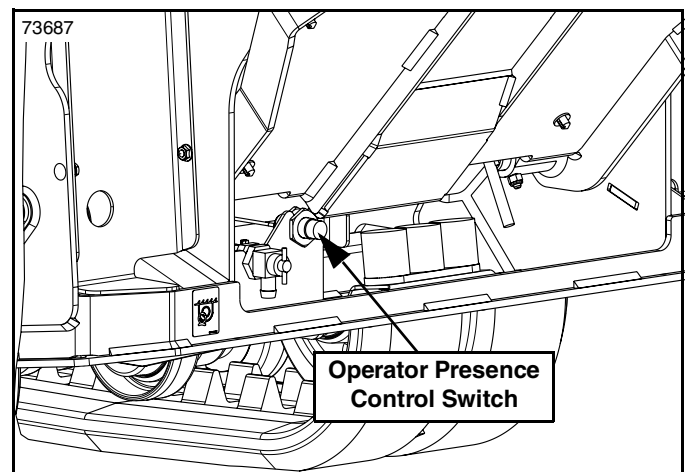

Operator Presence Control Switch Location
Figure 3-1

Section 3: Operating

Operator Platform Adjustment

Refer to Figure 3-2:

The operator platform can be adjusted for heavier or lighter operators to ensure that the operator presence control functions properly.

1. Lift operator platform (#1) to access rubber bumper assembly (#3).
2. Loosen flange nuts (#2) enough to adjust rubber bumper assembly (#3).
3. Adjust rubber bumper assembly to desired location by sliding it forward or back.

NOTE: The rubber bumper assembly adjusts to allow more or less “suspension” on the operating platform. Moving the rubber bumpers towards the front of the machine makes the operator platform more springy, moving them towards the back of the machine makes the operator platform more firm. Typically, for lighter operators, the rubber bumper assembly should be adjusted towards the front of the machine and towards the back for heavier operators.

4. Tighten flange nuts (#2) to correct torque.

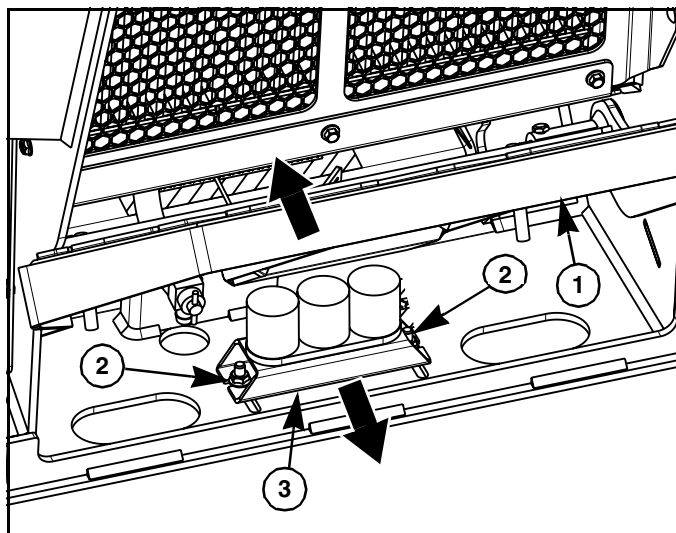

Operator Platform Adjustment
Figure 3-2

Starting The Engine

DANGER

To avoid serious injury or death:

Do not operate the machine in an enclosed area without proper ventilation.

WARNING

To avoid serious injury or death:

- Always start the engine from the operator's platform. Do not start the engine while standing next to the machine.

- Before starting engine, be sure no one is near the machine.
- The Operator should not depend solely on the warning lamps, but should always perform the operating checklist. See “Operating Checklist” on page 17.

IMPORTANT: Do not use starting fluid or ether.

IMPORTANT: In order not to overload the battery and starter, avoid start-ups of more than 10 seconds. When the engine does not start in 10 seconds, wait 20 seconds or more, before trying to start again. If the battery is dead and must be connected to another battery with jumper cable, be sure to use a 12V battery. Never use 24V batteries.

Perform the following steps to start the engine.

1. Set the throttle lever to low throttle.
2. Flip power switch to the on position.
3. A start up screen will appear on the monitor. It will ask for your passcode. Enter your passcode using the buttons on the control monitor.

NOTE: A passcode will be provided by your dealer at the time of purchase. You can then change the passcode whenever desired.

4. When correct passcode has been entered, you will advance to a new screen. Proceed as follows.
 - **Under normal conditions** press the middle button on the monitor to start the engine.
 - **Under cold conditions** press the button under the glow plug lamp. The glow plug lamp will then turn green. Wait for the green glow plug lamp to turn off. Press middle button to start the machine. Let the engine warm up after start-up for approximately 5 minutes under no load conditions. If the hydraulic fluid temperature is too low, the operations or the function of the pilot controls will be affected. Do not operate the machine under full load before the engine has warmed up.

Starting With An Auxiliary Battery

Refer to Figure 3-3:

WARNING

To avoid serious injury or death:

- Do not smoke and keep sparks and flames away. Battery gases can explode.
- Do not start the engine with an auxiliary battery if machine battery is frozen.

Observe the following guidelines when starting with an auxiliary battery.

1. Bring the helping machine with the same battery voltage as near as possible to the machine.

Section 3: Operating

IMPORTANT: The machines must not come in contact with each other.

2. Turn the helping machine off.
3. Wear eye protection and rubber gloves.
4. Ensure vent caps are securely in place (if equipped).
5. Connect red jumper cable to positive (+) terminal of the low battery then connect the other end to the positive (+) terminal of the auxiliary battery.
6. Connect the black jumper cable to the negative (-) terminal of the auxiliary battery then connect the other end to a conductive part of the machine frame (bare metal) as far away as possible from the low battery.

IMPORTANT: Do not connect the black jumper cable to the negative (-) terminal of the machine battery.

7. Start the engine of the helping machine and let it run for a while. Start the machine with the low battery.
8. Disconnect the jumper cables in the reverse sequence.

IMPORTANT: This machine has a negative (-) ground 12 Volt starting system. Only use the same voltage when using an auxiliary battery. Using a higher voltage will cause serious damage to the electrical system. When using an auxiliary battery, only the compatible (same) voltage is permissible.

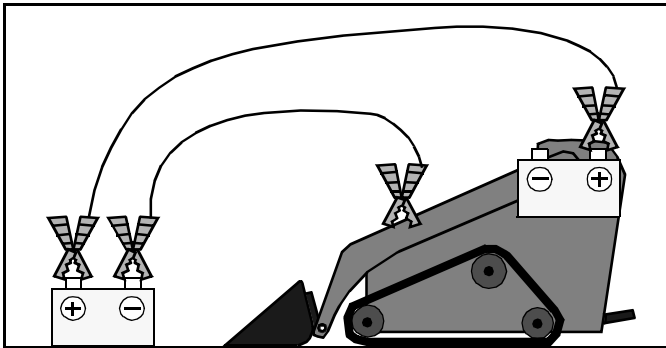

Auxiliary Battery Hook-up
Figure 3-3

Shutting Off The Engine



WARNING

To avoid serious injury or death:

- Before shutting engine off, fully lower loader arms. Do not keep the bucket or attachment in the raised position, the levers could accidentally be activated and cause serious accidents.
- Place the machine on flat level ground.

SCL Shutdown Procedure

The following are basic stand-on compact loader shutdown procedures. Follow these procedures before leaving the operator platform.

1. Park on solid, level ground.
2. Reduce engine speed.
3. Shut-off auxiliary power to attachment (if applicable).
4. Lower the loader arms and attachment (if applicable) until it is flat on the ground or on non-concrete support blocks.
5. Press the middle button on the control monitor to stop the engine, and turn the power switch off.
6. Wait for all components to come to a complete stop before leaving the operator platform.

IMPORTANT: Let the engine idle at low throttle for 1-2 minutes before shutting engine off. This helps cool the engine before shutting off. In the case of an emergency you can shut the engine off immediately by turning off the power switch.



Monitor with Splash Screen Displayed
Figure 3-4

Control Monitor Function

The following is a detailed description of the control monitor's functions and instructions for operating the monitor. Toggle the power switch on to power up the control monitor.

NOTE: The monitor buttons are not numbered on your machine as shown in the following images. They are numbered here for reference only.

Splash Screen

Refer to Figure 3-4:

The first screen displayed on the monitor is the **Splash** screen. This screen will display for a few seconds until it loads up. Full reboot with the **Splash** screen only occurs after the power has been off for more than 30 minutes. A button ribbon at the bottom of the screen will also be displayed. The ribbon will indicate the functions for each button.

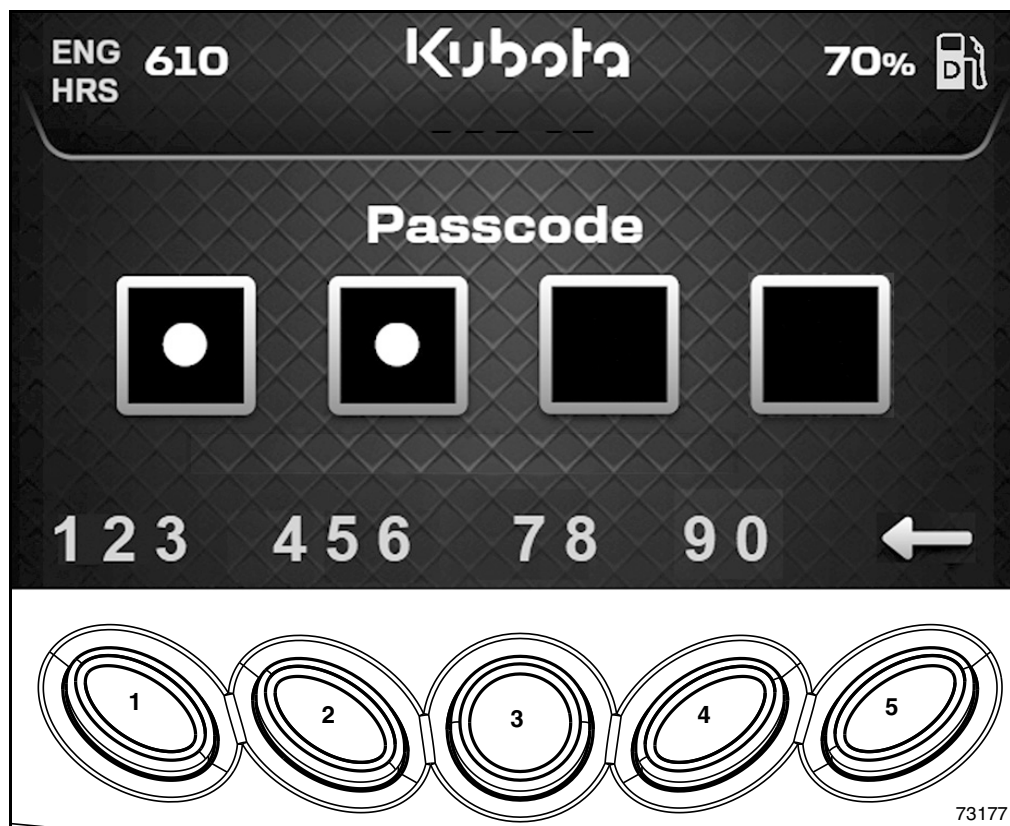

Passcode Screen
Figure 3-5

Passcode Screen

Refer to Figure 3-5:

After the **Splash** screen, if startup passcode is enabled, the **Passcode** screen will display. This screen will show engine hours in the upper left corner, the fuel percentage level in the upper right corner and boxes in the center of the screen for the 4-digit owner or user passcode. The operator must enter the 4-digit passcode to advance to the **Home** screen and begin operation.

The first four buttons on the **Passcode** screen are associated with four groups of numbers and the fifth button is a backspace:

Button (#1) [1,2,3]

Button (#2) [4,5,6]

Button (#3) [7,8]

Button (#4) [9,0]

Button (#5) Backspace:

Press the backspace to move back to the previous digit box

For example, if the user code is 9325, the operator would press buttons 4, 1, 1, 2. When entering the code, the first box is selected by default. Once a value is entered, the selection automatically advances to the next box. When a value is entered in the fourth box, the passcode is automatically checked. If the code is incorrect, the entry

is reset and “Invalid passcode” is displayed. If correct, the **Home** screen appears.

The monitor will remain on as long as the power switch is flipped on. If the power switch is flipped off, the monitor will black out. If the monitor is blacked out for longer than 30 minutes, the Operator will have to re enter the passcode to resume.

NOTE: A 4-digit owner passcode will be provided by your dealer at the time of purchase. You can then add a user passcode and also change the owner passcode as desired. See “**Passcode Management Screen**” on page 29.

Forgotten passcodes can be retrieved. See “**Passcode Management Screen**” on page 29.

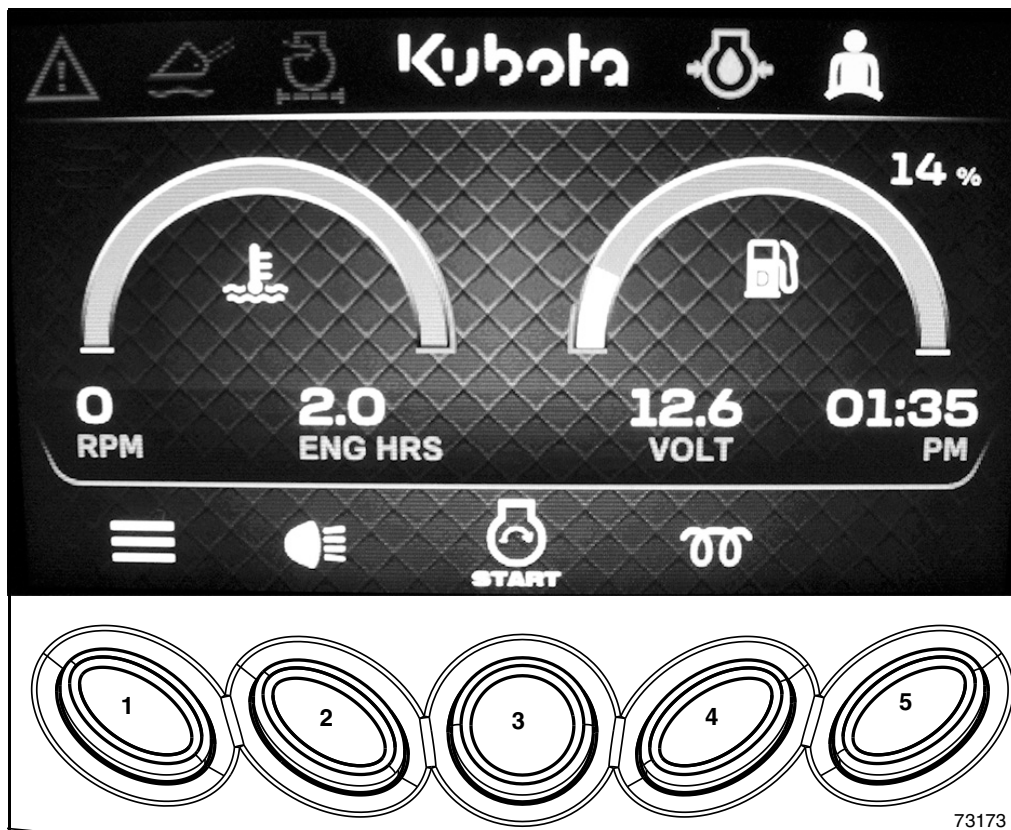

Home Screen
Figure 3-6

Home Screen

Refer to Figure 3-6:

The **Home** screen will display all the following data:

- **Temperature gauge**



The temperature gauge is displayed as a half circle on the left side of the screen. The gauge will turn red when the engine is overheating. When the engine is critically hot, the gauge will flash.

- **Fuel gauge**



The fuel gauge is displayed as a half circle on the right side of the screen. The fuel level percentage is displayed to the upper right of the gauge. The gauge turns red at 10% and flashes at 5%.

- **Operator presence light**



The operator presence light will display green when the Operator is on the operator platform. The light will be red otherwise.

- **Service required light**



The service required light will display red if any service reminder items are overdue. The light will stay on until all overdue items have been reset. See “**Service Reminders Screen**” on page 26.

- **Low oil pressure alert**



The low oil pressure light will display in red when the engine oil pressure is too low. If the

machine is in operation and the low oil pressure sensor is triggered, an alert will appear saying “**WARNING: LOW OIL PRESSURE. When safe, shutdown immediately to avoid engine damage.**” After 6 seconds if the machine is still in operation, the engine will automatically shutdown and the alert changes to “**Engine auto-shutdown due to low oil pressure.**” The Operator must acknowledge by pressing submit button to clear it.

- **Air cleaner full light**



The air cleaner full light will display in red when the air cleaner is clogged and needs cleaned.

- **Float activated light**



The float activated light will display green when the float function is activated. See “**Float Function**” on page 33.

- **RPM**

Engine RPMs (revolutions per minute) are displayed under the temperature gauge.

- **Engine hours**

Engine hours displayed under the temperature gauge.

- **Battery voltage**

Battery voltage is displayed under the fuel gauge. If the engine is off, the battery voltage flashes red if voltage drops below 11.5V. If the engine is on, the battery voltage flashes red if voltage drops below 12.5V.

Section 3: Operating

• Real time clock

The time is displayed under the fuel gauge as a digital clock. The time can be adjusted in the settings menu.

Home Screen Button Functions

Refer to Figure 3-6:

The button functions are represented by corresponding icons at the bottom of the screen.

Before starting the engine, the buttons are:

Button (#1) Menu:

Press button (#1) in the Home screen to go to the Menu screen.

Button (#2) Work light:

Press button (#2) in the Home screen to toggle the machine's work light on and off.

NOTE: The work light will stay on for 30 seconds after the power switch has been switched off.

Button (#3) Start:

Press and hold button (#3) to power on the engine. The start icon will light green while the starter is cranking.

Button (#4) Glow plugs:

Press button (#4) once to activate glow plugs for 5 seconds, or press the button up to 6 times to activate the glow plugs for 30 seconds (5 seconds for each press of the button). This process may be repeated after the 30 seconds is up. A countdown timer will be displayed under the glow plug icon. The glow plug icon will turn green while the glow plugs are activated.

Button (#5) Disabled:

Button (#5) has no function in the Home screen while the engine is off.

With engine running, buttons 1, 2, and 5 retain the same function, buttons 3 and 4 change as follows:

Button (#3) Stop:

Refer to Figure 3-7:

Press button (#3) to turn power off to the engine (do not need to hold the button).

NOTE: Power switch (#3) in Control Panel also acts as an emergency engine kill switch.

Button (#4) Hydraulics:

Refer to Figure 3-7:

With the engine on and the Operator present on the operator platform:

Press button (#4) to toggle hydraulics on and off. The hydraulics unlocked icon displays green when the hydraulics are on.

NOTE: With the hydraulics unlocked, if the Operator leaves the operator platform, the hydraulics lock automatically while away and unlock automatically when the Operator returns to the operator platform.

IMPORTANT: Hydraulics can only be unlocked when engine RPMs are below 1500. If the Operator attempts to unlock the hydraulics while the engine RPMs are above 1500, an alert will pop up saying "Reduce engine speed to less than 1500 RPM." See Figure 3-8.



Home Screen Machine On
Figure 3-7



Reduce RPM
Figure 3-8

Section 3: Operating

With the engine on and the Operator NOT present on the operator platform:

Refer to Figure 3-9 & Figure 3-10:

Press button (#4) to begin operator presence override. A prompt “Temporarily override operator presence control?” appears. Press button (#2) to submit or button (#4) to cancel. “Cancel” returns you to the Home Screen. “Submit” will move you to a second prompt: “Park brake will disengage. Drive and loader controls will be enabled. Operate with extreme caution.” Press button (#2) to submit or button (#4) to cancel. “Cancel” returns you to the Home screen. “Submit” activates the hydraulics and returns you to the Home screen. The hydraulics unlocked icon will display green.

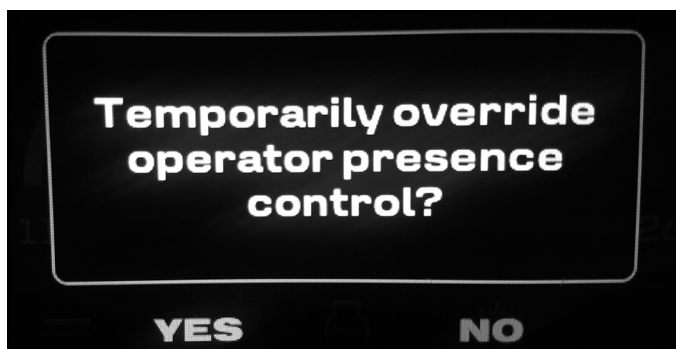

Operator Presence Control Override Prompt 1
Figure 3-9



Operator Presence Control Override Prompt 2
Figure 3-10

NOTE: The override will turn off if the engine shuts down, the hydraulics are turned off, or if the Operator becomes present on the operator platform. In the case of the Operator becoming present, the override will turn off, but the hydraulics will remain unlocked.

NOTE: The auxiliary hydraulics and float functions are not enabled while the machine is in manual override.

With engine on, Operator on operator platform and hydraulics unlocked, float function and AUX controls become available and button 5 changes as follows:

Refer to Figure 3-11:

Button (#5) Auxiliary Hold Mode:



Press button (#5) to toggle the AUX hold on and off. The AUX hold icon will display green when AUX hold is on. With AUX hold on, press the button on the loader handle that operates the hydraulic flow in the direction intended for your application. Press the button part way to soft start or press all the way to hard start. See “Figure 3-29” on page 33. AUX hold will keep the auxiliary running after releasing the button. Press the same button part way to soft stop or press all the way to hard stop. Pressing the opposite auxiliary button or both auxiliary buttons at same time will hard stop as well. Press button (#5) to exit AUX hold mode.

NOTE: Soft start means auxiliary slowly comes up to max speed rather than immediately as in a hard start. Likewise soft stop slowly reduces hydraulic fluid to a stop rather than immediately as in a hard stop.

The max speeds can be adjusted via the max settings in the **auxiliary flow** menu. See “Auxiliary Flow Screen” on page 26.

NOTE: The auxiliary hold mode turns off any time the hydraulics are turned off from the monitor or when the Operator leaves the operator platform.

Float

With loader arms and attachment lowered to the ground, press button (#11) on the loader handle to activate the float function (See “Figure 3-29” on page 33). The float icon will display green when activated. The loader arms and attachment will follow the contours of the ground while in “float”. The float function can only be enabled when the hydraulics are unlocked, however, not when the operator presence is overridden. To deactivate the float function, press button (#11) on the loader handle or pull back on the loader handle as if raising the loader arms.



Float On
Figure 3-11



Menu Screen
Figure 3-12

Menu Screen

Refer to Figure 3-12:

The **Menu** screen provides access to **Auxiliary Flow**, **Service Reminders**, **Settings**, and **Passcode Management** screens. Warning icons are still displayed at the top of the screen as they were in the **Home** screen, with the exception of the operator presence icon and the addition of the engine temperature overheat and low fuel icons.

The button functions are represented by corresponding icons at the bottom of the screen. Button functions are as follows:

Button (#1) Home:



Press the home button to take you back to the **Home Screen**.

Button (#2) Back:



Press the back button to return you to the previous screen.

Button (#3) Submit:



Press the submit button to accept an option and move to the next screen.

Button (#4) Down:



Press the down button to scroll down through the list of options.

Button (#5) Up:



Press the up button to scroll up through the list of options.

Auxiliary Flow Screen

From the **Menu** screen, select **Auxiliary Flow** to adjust the auxiliary controls response.

Refer to Figure 3-13:

In the “Auxiliary Flow” screen, buttons 3, 4 and 5 change as follows:

Button (#3):

 Button (#3) as well as button (#2) will move you forward or backwards to select from **Left Max**, **Right Max**, **Left Min** and **Right Min**.

Button (#4) Decrease:

 Press button (#4) to decrease the value of the selected option.

Button (#5) Increase:

 Press button (#5) to increase the value of the selected option.

Adjustment may be necessary if weather, temperature or job site conditions change significantly or if changing to a different attachment requiring lower flow (ex. cylinders) or higher flow (ex. motors).

Adjusting the Max sets how fast the auxiliary runs when the button is pushed all the way down. Adjusting the Min sets how far you need to press the auxiliary hydraulic buttons before getting a response from the attachment. Always set Max first because Min is affected by Max but Max is not affected by Min. For best control, set Max as low as possible while maintaining desired full speed of attachment.



AUX Flow Screen
Figure 3-13

Service Reminders Screen

The **Service Reminders** screen displays hours remaining before the next service for the following items:

- Air cleaner filter
- Engine oil & filter
- Fan belt
- Fuel filter
- Hydraulic oil filter
- Hydraulic oil change
- Hydraulic tank breather
- Coolant change

In the **Service Reminders** screen, the Operator also has the ability to view important information regarding each of the service items listed.

Refer to Figure 3-14 & Figure 3-15:

In the “Service Reminders” screen, all buttons except button 3 retain same function. Button 3 changes as follows:

Button (#3) Info:

 Highlight an item in the **Service Reminders** screen then press button (#3) to open another screen which lists the following information for each item:

- service item name
- amount of hours left until next service
- service life
- specs about the service item



Service Reminders Screen
Figure 3-14

Service hours should be reset every time a service is performed to ensure the Operator has an accurate timetable of when the next service should be performed.

Section 3: Operating

Refer to Figure 3-15, Figure 3-16 & Figure 3-17

In the information screen, buttons 1 and 2 retain the same function, buttons 4 and 5 have no function and button 3 changes as follows:

Button (#3) Reset:

 Press button (#3) to begin the reset process of interval selected. Upon pressing button (#3), you will need to enter the owner passcode (user passcode will not grant access). After entering the passcode the following prompt will show. “**Are you sure you want to reset: [item]?**”. Press button (#2) to submit or button (#4) to cancel.

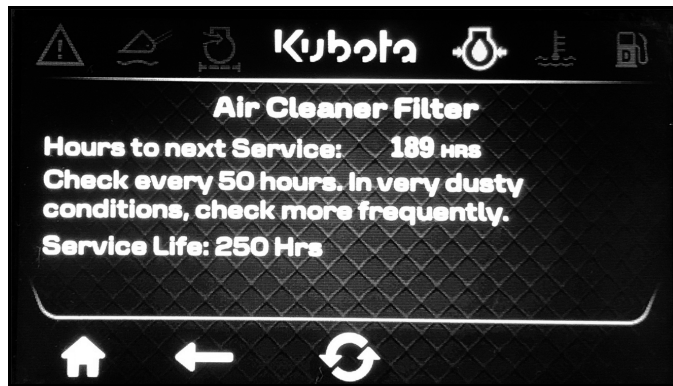

Information Screen
Figure 3-15



Passcode Entry for Service Item Reset Screen
Figure 3-16

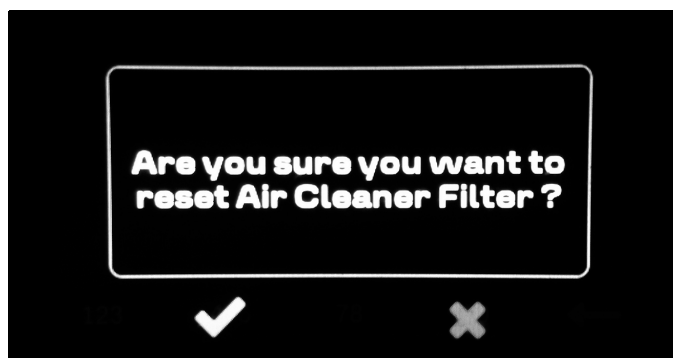

Confirmation Reset for Service Item Screen
Figure 3-17

NOTE: The bars in the bar graphs turn from green to yellow when 24 hours or less are left before the next servicing is due. When servicing is overdue, the service required light comes on, the bars in the bar graph change from yellow to red and the hours next to the service item will start counting negative.

Settings Screen

The following items can be adjusted in the **Settings** screen:

- Language
- Software Info (Software update)
- Real Time Clock (Adjustable time clock)

Language

Refer to Figure 3-18:

With the “Language” setting highlighted, buttons retain the same function as in the Menu Screen except button #3 which changes as follows:

Button (#3) Toggle:

With the “Language” setting highlighted, press button (#3) to select from available languages.



Language Setting
Figure 3-18

Software Information (Update software)

Refer to Figure 3-19:

With the “Software Info” setting highlighted, all buttons retain the same function as in the Menu Screen except button #3 which changes as follows:

Button (#3) Software Update:

NOTE: Contact your dealer about software updates.



Software Setting
Figure 3-19



Time Clock Setting
Figure 3-20

Real Time Clock (adjustable)

Refer to Figure 3-20, Figure 3-21 & Figure 3-22:

With the “Real Time Clock (RTC)” setting highlighted, all buttons retain the same function as in the Menu Screen.

Button (#3):

With the “Real Time Clock (RTC)” setting highlighted, press button (#3) to open the time clock setting screen.

See Figure 3-21. In the time clock setting screen the button functions change as follows:

Button (#1) Toggle:

Toggles between the hours box and minutes box.

Button (#2) Back:

Takes you back to the Settings screen.

Button (#3) Set:

Begins the process of setting the changes made to the clock. A prompt will pop up saying “Power cycle is required to set the clock. Press YES to set the clock or press NO”

NOTE: Pressing “YES” will shut down the entire machine and reboot

Button (#4) Down:

Lowers the hour or minute number value.

Button (#5) Up:

Raises the hour or minute number value.



Time Clock Set Screen
Figure 3-21

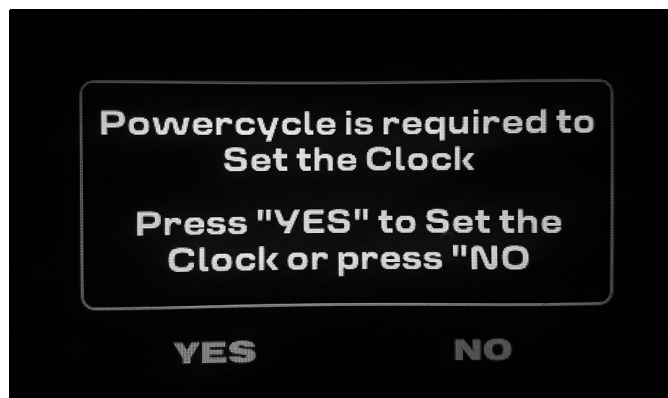

Powercycle Prompt
Figure 3-22

Section 3: Operating

Passcode Management Screen

To access the **Passcode Management** screen, the Operator must enter the owner passcode (user passcode will not grant access).

NOTE: If the owner passcode has been forgotten, it may be retrieved. See “**Master Passcode (6-digit)**” below.

In this screen, the Operator can enable or disable the requirement of a passcode to startup the machine. The Operator can also change the owner passcode and user passcode in this screen. The current user passcode is shown next to the “Change User Passcode” option when it is highlighted. Likewise, the current owner passcode is shown next to the “Change Owner Passcode” option when it is highlighted.

There are three levels of passcodes:

- **Master passcode (6-digit)**

The master passcode can be entered during any prompt for a passcode by pressing and holding any button for 2 seconds. If the master passcode entered is valid, the owner passcode will be shown. After noting the code, click button (#3) to exit and retry using the owner passcode.

NOTE: The master passcode is intended for when the owner passcode is forgotten. This is a randomly-generated, hard-coded, unchangeable passcode unique to each machine. Dealers will have access to the master passcode in the event that the Owner forgets the master passcode.

- **Owner passcode (4-digit)**

The owner passcode grants access to protected settings and also passes as a user passcode.

NOTE: The machine will be pre-programmed with an owner passcode. This passcode can be changed as desired.

- **User passcode (4-digit)**

The user passcode grants access to basic machine operations. The machine will not come with a pre-programmed user passcode. Initially, the owner passcode will be used to unlock the machine. The Owner can then set-up a user passcode if desired through the “Change user Passcode” screen.

Startup Passcode

Refer to Figure 3-23:

With “Startup Passcode” highlighted, buttons 1,2,4 and 5 retain the same function as in the Menu Screen. Button 3 changes as follows:

Button (#3) Toggle:

Press button (#3) on “Startup Passcode” to enable or disable a startup passcode.

- **Enabled:** If “Startup Passcode” is enabled, after the Operator has flipped the power switch on and the **Splash** screen is done loading, the machine will ask for a passcode (user or owner passcode) to advance to the **Home** screen.
- **Disabled:** If “Startup Passcode” is disabled, after the Operator has flipped the power switch on and the **Splash** screen is done loading, the machine will bypass the **Passcode** screen and advance straight to the **Home** screen.



Passcode Management Screen
Figure 3-23

Change User Passcode

Refer to Figure 3-24 & Figure 3-25:

When changing the user passcode, button functions are as follows:

Button (#1) Home:

Home button takes you back to the **Passcode Management** screen.

Button (#2) Left:

Cursor left button will move you back to the previous digit box.

Button (#3) Right:

Submit button will move you forward to the next digit box. If the submit button is pressed when on the last digit box, the code will be submitted.

Button (#4) Down:

Down button decreases the number value in the digit box.

Button (#5) Up:

Up button increases the number value in the digit box.

After submitting the new user passcode, a prompt will pop up. The prompt will say “**Setting user code to [number entered]. Is this correct?**”. Press button (#2) to submit and complete the passcode change, or press button (#4) to cancel and return to the Passcode Management screen.

Change Owner Passcode

Refer to Figure 3-26 & Figure 3-27:

When changing the owner passcode, button functions are as follows:

Button (#1) Home:

Home button takes you back to the **Passcode Management** screen.

Button (#2) Left:

Cursor left button will move you back to the previous digit box.

Button (#3) Right:

Submit button will move you forward to the next digit box. If the submit button is pressed when on the last digit box, the code will be submitted.

Button (#4) Down:

Down button decreases the number value in the digit box.

Button (#5) Up:

Up button increases the number value in the digit box.

After submitting the new owner passcode, a prompt will pop up. The prompt will say “**Setting owner code to [number entered]. Is this correct?**”. Press button (#2) to submit and complete the passcode change, or press button (#4) to cancel and return to the Passcode Management screen.

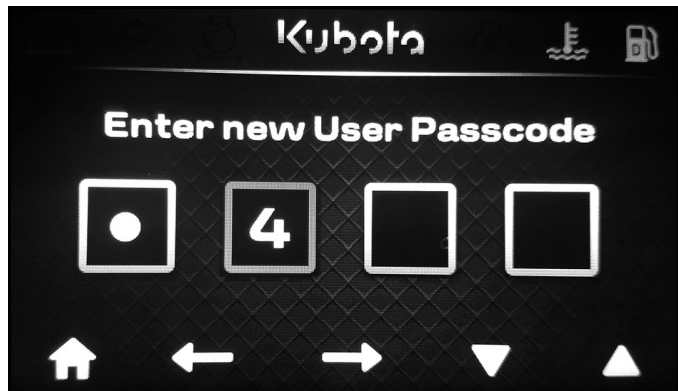

New User Passcode Screen
Figure 3-24

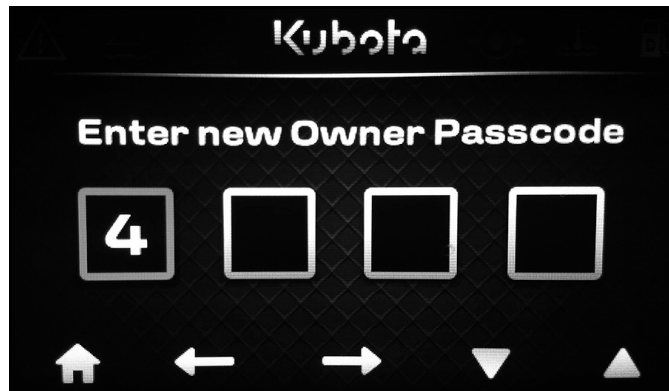

New Owner Passcode Screen
Figure 3-26

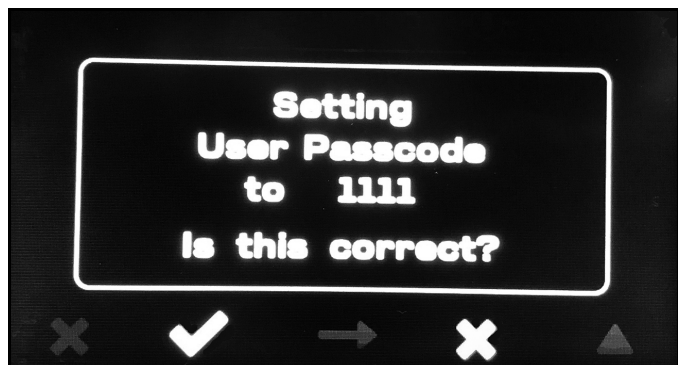

User Passcode Change Prompt
Figure 3-25

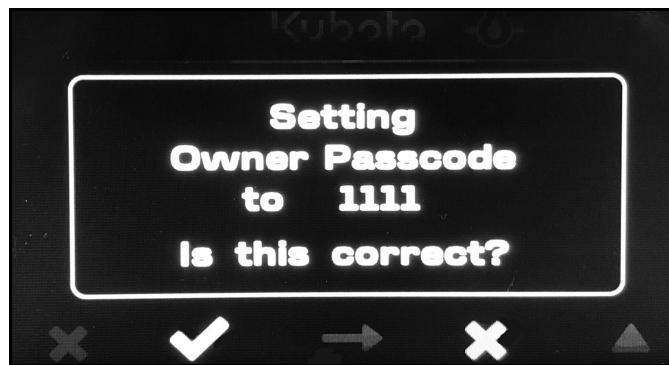

Owner Passcode Change Prompt
Figure 3-27

This page intentionally left blank.

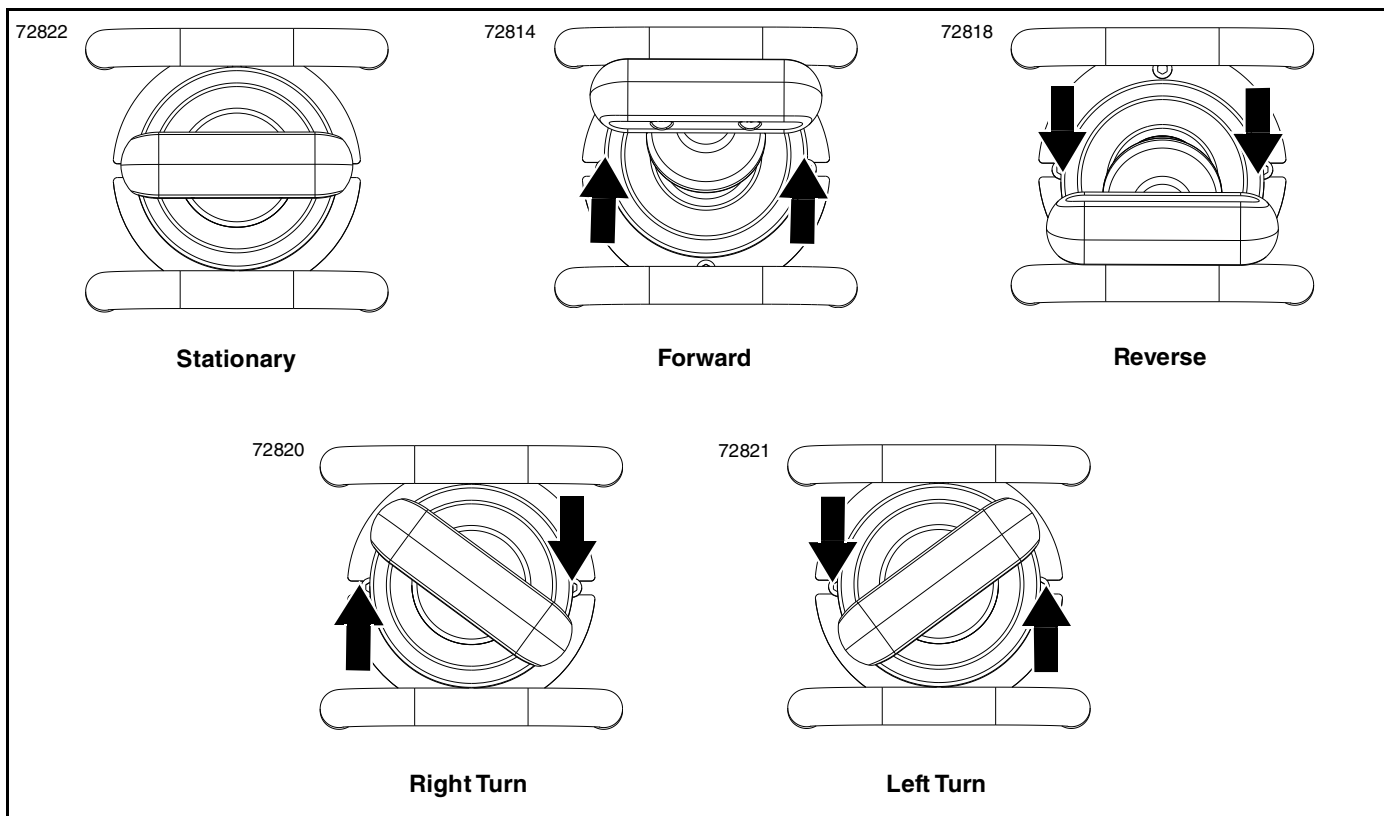

Drive Handle Functions
Figure 3-28

Drive Handle Operation

Refer to Figure 3-28:

Use the drive handle to maneuver the machine. The further you push or pull on the drive handle in any direction, the faster the machine will move in that direction. For best performance, operate the machine at full throttle.

IMPORTANT: It is best to ease off the drive handle when wanting to come to a stop. If you abruptly release the drive handle while in motion, it can create a jerking motion.

Driving the Machine

WARNING

To avoid serious injury or death:

- Never make sudden stops or sudden reversing of travel direction, especially when going down a slope. The steering is designed for sensitive response. Rapid movement of the drive handle could result in a reaction that can cause serious injury.
- Never make sudden speed changes. Always push drive handle gently to avoid sudden changes in speed.
- When operating the machine, always be aware of surroundings. The Operator must constantly be aware of any obstructions, obstacles, bystanders and animals.

- Never drive recklessly. Terrain condition can affect the machine's traction and Operator control. Reduce speed if surface conditions are uneven, rough, wet, slick, or when traveling over holes, loose soil, sand, gravel, or other unstable surfaces.
- When reversing, look behind you for obstructions, obstacles, bystanders and animals.
- Do not drive the machine down roadways, it is not equipped for safe road travel.
- When changing direction be aware of people and animals in the work area.
- Make sure the bucket or attachment is lowered to the ground as much as possible without it catching on the ground.

Forward and Backward

To travel in a forward direction, push the drive handle forward as shown in "Figure 3-28".

To travel in a reverse direction, pull the drive handle back as shown in "Figure 3-28".

Turning

To turn right, turn the drive handle clockwise as shown in "Figure 3-28".

To turn left, turn the drive handle counter clockwise as shown in "Figure 3-28".

Section 3: Operating

Loader Handle Operation

Refer to Figure 3-29:

WARNING

To avoid serious injury or death:

- Do not exceed the rated operating capacity of the machine.
- If operating a bucket, or other lifting attachments, be careful not to tilt the bucket/attachment all the way back when the loader arms are raised all the way up. Material could fall back onto the Operator.

Tilt the attachment forward by slowly moving the loader handle to the right.

Tilt the attachment backward by slowly moving the loader handle to the left.

Lower the loader arms by slowly moving the loader handle forward.

Raise the loader arms by slowly moving the loader handle backward.

To operate the loader arms and tilt at the same time, maneuverer the loader handle toward positions 5, 6, 7 or 8. See **Figure 3-29**.

Float Function

Refer to Figure 3-29:

WARNING

To avoid serious injury or death:

Make sure the attachment is lowered to the ground before putting lift arms in "FLOAT" position. Putting the lift arms in "FLOAT" position while they are off the ground will cause the attachment and lift arms to fall.

Grading attachments should be operated in float function. The float function allows the attachment to follow the contours of the ground. Read the following instructions for operating the float function.

1. Lower the attachment to the ground then press float button (#11) to engage float function. Proceed to operate attachment.
2. To exit float function, either press float button (#11) or pull back on the loader handle to raise the loader arms and exit the float function. See **"Float"** on page 24 for additional information on the float function.

Auxiliary Hydraulics

Refer to Figure 3-29:

WARNING

To avoid serious injury or death:

- Wear protective gloves and safety glasses or goggles when working with hydraulic systems. Hydraulic fluid under pressure can penetrate skin. Use a piece of cardboard or wood rather than hands when searching for hydraulic leaks. If hydraulic fluid is injected into the skin, it must be treated by a doctor within a few hours or gangrene may result.

- Stop the engine and relieve hydraulic pressure before connecting or disconnecting hydraulic lines.

Some attachments require auxiliary hydraulic power to operate. Read the following instructions and notes on how to operate the auxiliary hydraulics.

Press and hold button (#9) to operate auxiliary hydraulics in a forward direction or press button (#10) to operate the auxiliary hydraulics in a reverse direction. Release the button to cut off auxiliary hydraulic flow.

Auxiliary hydraulic speed can be controlled by increasing or decreasing engine throttle and also by how deep the buttons are pressed (press button all the way down for full flow. Button response can be adjusted. See **"Auxiliary Flow Screen"** on page 26.

Auxiliary Hold Mode

Maintain auxiliary hydraulic power without holding a button with auxiliary hold mode. This function can be activated from the monitor. See **"Auxiliary Hold Mode"** on page 24.

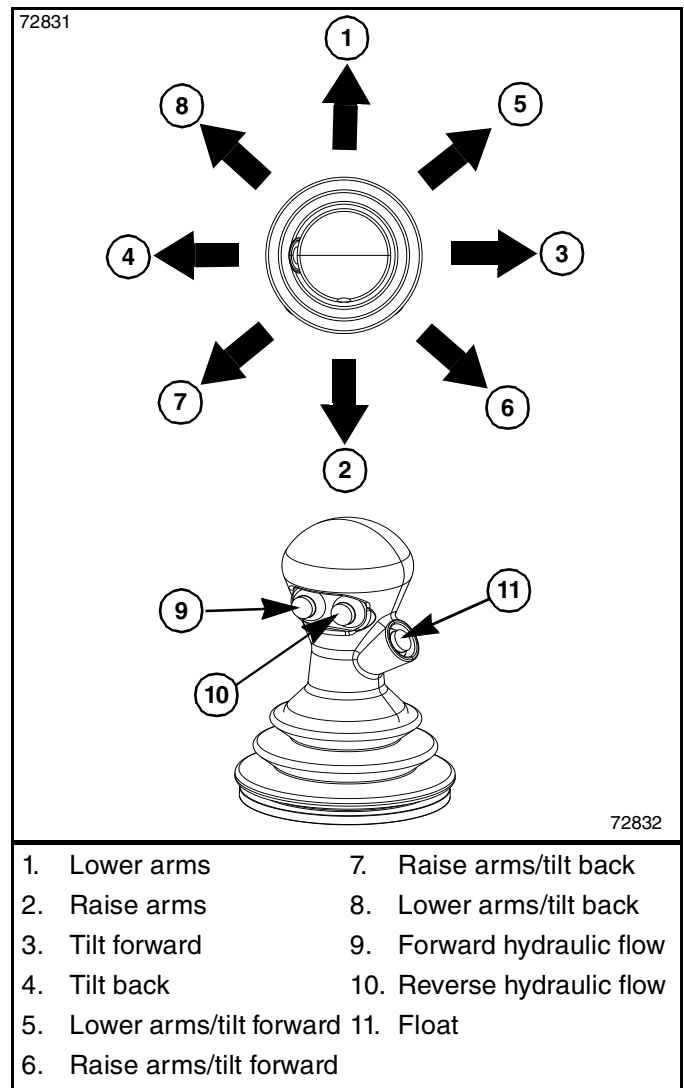

Loader Handle Functions
Figure 3-29

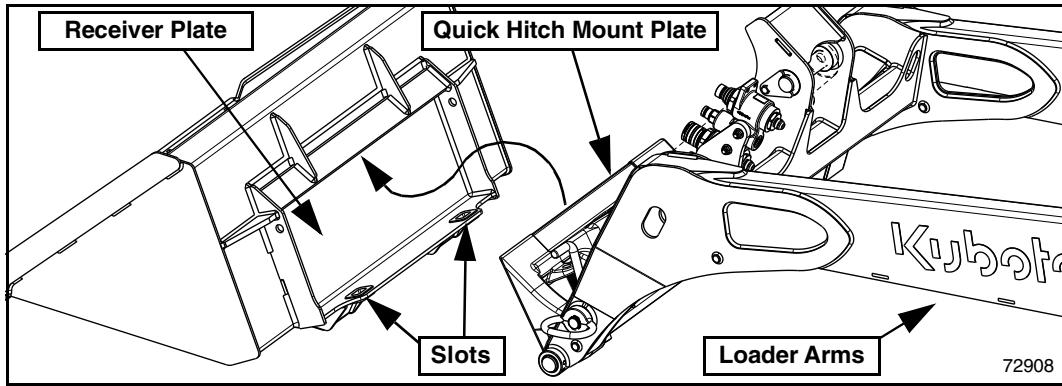

Attachment Hookup
Figure 3-30

Attachments

WARNING

To avoid serious injury or death:

- Use only Kubota approved attachments with this machine. Using other brand attachments may create an unsafe operating environment and/or damage the machine.
- Do not alter attachments or replace parts on the attachment with other brands. Other brands may not fit properly or meet OEM specifications. They can weaken the integrity and impair the safety, function, performance, and life of the attachment. Replace parts only with genuine Kubota parts.

A selection of Kubota approved attachments are available for use with the stand-on compact loader. Kubota attachments will aid in expanding the stand-on compact loader's capabilities. Contact your nearest Kubota dealer for a list of approved attachments.

Connecting an Attachment

Refer to Figure 3-30 & Figure 3-31:

This machine utilizes a CII hitch mounting plate for easy connection and disconnection of various attachments.

DANGER

To avoid serious injury or death:

- A crushing hazard exists when hooking-up and unhooking the attachment. Do not allow anyone to stand between attachment and power machine while approaching or backing away from the attachment. Do not operate hydraulic controls while someone is near the power machine and/or attachment.
- The hitch latch pins on the quick-hitch mount plate must protrude into and through the pin slots of the attachment on both sides. It is critical that the pins are in good condition and without visible signs of wear or damage and that the Operator align the quick-hitch mount plate with the attachment to allow the pins to go through the pin slots. Do not operate the machine or attachment unless all of the above conditions are met.

WARNING

To avoid serious injury or death:

- Check hitch fit-up frequently. An improper fit-up can cause the attachment to come loose from the loader hitch plate and fall.
- Never operate or transport attachments which are not attached completely.
- Always visually inspect for broken or damaged pins. Replace damaged hardware immediately.

NOTE: Attachments should be located on a level, firm surface when attaching and detaching them from the quick-hitch mount plate.

1. To mount an attachment, put the hitch latch pins in the unlocked position by turning them so the handles are pointing toward the outside. Make sure the hitch latch pins are pulled up all the way to ensure a proper hook-up. Refer to **Figure 3-31**.
2. Position the machine squarely in front of the attachment and tilt the quick-hitch mount plate forward with the loader handle.
3. Ease the quick-hitch mounting plate into the lip of the attachment's receiver plate. Refer to **Figure 3-30**.
4. Roll the quick-hitch mount plate back using the loader handle and raise the lift arms slightly. The back of the attachment receiver plate should rest against the front of the quick-hitch mounting plate and the weight of the attachment should be supported by the loader arms.
5. When the attachment is properly seated, turn engine off. See "**SCL Shutdown Procedure**" on page 19. Set the hitch latch pins in locked position by turning the handles so they face inside. Verify that both pins are completely engaged and go through the slots on the attachment base. Refer to **Figure 3-31**.
6. Visually verify when pushing the hitch latch pins into the locked position that the pins protrude through the slots on the attachment.

Section 3: Operating

Connecting to Auxiliary Hydraulics

Refer to Figure 3-32:

If connecting an attachment that operates with auxiliary hydraulics, adhere to the following instructions.

! WARNING

To avoid serious injury or death:

- Stop the engine and relieve pressure before connecting or disconnecting hydraulic lines.
- Hydraulic fluid under high pressure can penetrate the skin and/or eyes causing a serious injury. Wear protective gloves and safety glasses or goggles when working with hydraulic systems. Use a piece of cardboard or wood rather than hands when searching for leaks. A doctor familiar with this type of injury must treat the injury within a few hours or gangrene may result. **DO NOT DELAY.**

! CAUTION

To avoid minor or moderate injury:

Hydraulic couplers, valves, lines and fluid may be hot and can burn you if you come in contact with them. wear gloves when handling hydraulic components.

Connecting Hydraulics

1. Shut engine down (See “SCL Shutdown Procedure” on page 19).
2. Remove dirt and debris from the surface of the male and female couplers, and from the outside diameter of the male couplers on the machine and attachment. Visually check the couplers for corrosion, cracking, damage or excessive wear. If any of these conditions exist, the coupler must be replaced.
3. Route hydraulic hoses through hose loop (#7).
4. Push the auxiliary hydraulic couplers (#1 & #3) in and hold for a few seconds to release hydraulic pressure.
5. Push the attachment’s male connector (#4) into the machine’s female connector (#3).
6. Push the attachment’s female connector (#6) onto the machine’s male connector (#1).
7. Push the attachment’s female case drain connector (#5) onto the machine’s male connector (#2) if applicable.
8. Pull on the hoses to make sure the couplers have connected properly.

Disconnecting Hydraulics

1. Lower attachment to the ground.
2. Shut engine down. (See “SCL Shutdown Procedure” on page 19).
3. Push auxiliary hydraulic couplers (#1 & #3) in and hold for a few seconds to release hydraulic pressure.
4. Pull the collars back on the female couplers to detach the hydraulic hoses from the machine.
5. Detach the couplers.

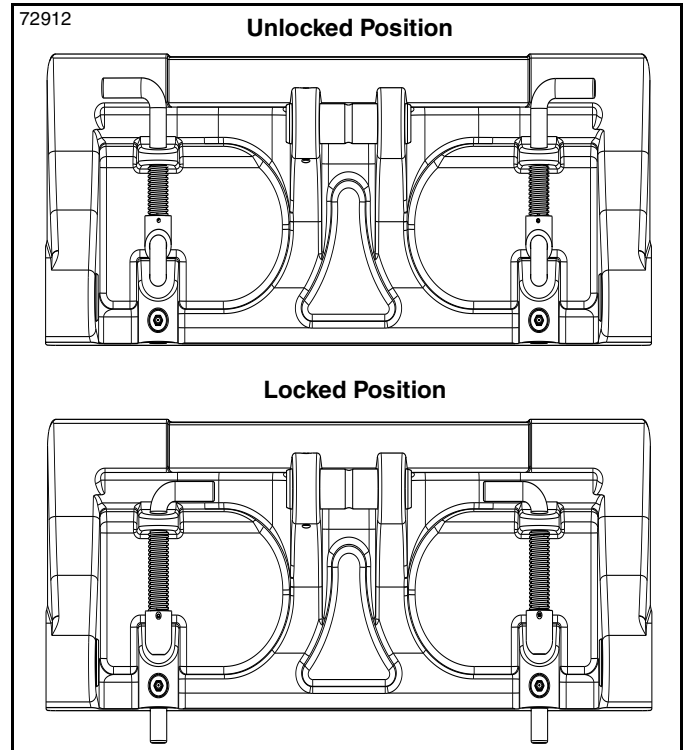

Hitch Latch Pins
Figure 3-31

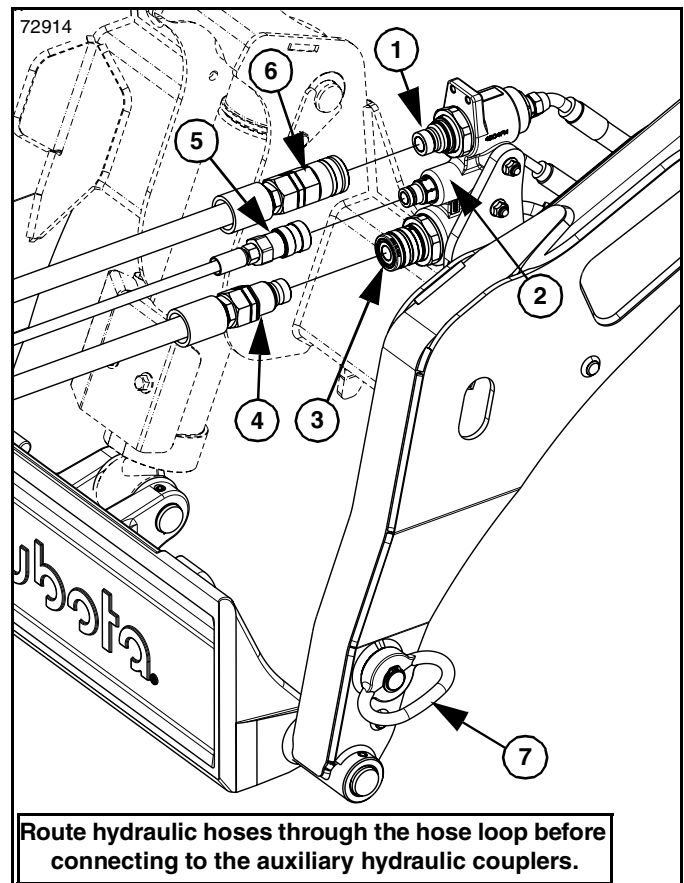

Auxiliary Hydraulics Hook-up
Figure 3-32

Section 3: Operating

Safe Operating Practices

It is absolutely essential that no one operates the machine unless they have read, fully understood, and are totally familiar with the Operator's Manual. It is imperative that the Operator comply with the safety instructions and practices and always pay attention to the danger, warning and caution alerts. Failure to comply with these instructions and practices may result in injury or death.

DANGER

To avoid serious injury or death:

- Do not operate this machine under the influence of alcohol or drugs, or if the Operator is ill or excessively tired.
- Check clearances when driving under objects such as doorways or large branches. Be aware of all overhead utility and electrical lines as well as having all underground lines marked if digging or trenching will take place.
- Never operate the machine in the vicinity of explosive gases. Always keep exhaust from machine away from any combustible material.
- Do not operate the machine in an enclosed area without proper ventilation.
- Always operate the machine in adequate light that will allow the Operator to identify any holes or other hazards.
- Make sure all guards and shields are installed and in good working condition when operating the machine.
- Keep bystanders and animals away while the machine and/or attachment is in use. A person or animal can be crushed, ran-over, entangled or suffer other serious injury. Stop the machine if anyone enters the work area.
- Never exceed the machine's rated lift capacity. Exceeding the rated lift capacity can result in equipment damage, roll over or other hazards.
- Use caution when raising loads and make sure not to overload the bucket/attachment. Maintain level when raising, as materials can fall back onto the Operator.
- Whenever the machine is in motion, keep the bucket/attachment as close to the ground as possible. Never change directions when the bucket/attachment is in the raised position. If you must move the machine with the bucket/attachment raised, take care to travel at low speeds in order to maintain control of the machine at all times.
- Pay attention to weather conditions. Rain or snow can make working conditions difficult and unsafe. Pay particular attention to lightning in your area. Do not operate the machine if lightning is seen, seek shelter.

WARNING

To avoid serious injury or death:

- Only use this machine for its intended purposes.
- Do not operate machine on loose rock or gravel.
- Always avoid working on an incline as the machine can become unstable and rollover.

- Read the attachment Operator's Manual before operating.
- Never use the machine to move material or perform work that exceeds the capacity of the bucket or attachment.
- Transport loads as low to the ground as possible to help prevent losing control of or tipping the machine. Practicing this caution will also prevent loads from shifting and falling.
- Do not alter the engine governor to over-speed machine.
- Never leave the machine running and unattended. Shut the machine down using shut down procedures provided in this manual before leaving the operator platform.
- Do not jerk the drive handle or the loader arm/tilt lever. Use the grip bars for leverage to help in operating in a steady motion.
- Only operate this machine in areas that you can maneuver the machine safely.
- Use only Kubota approved attachments with this machine. Using other brand attachments may create an unsafe operating environment and/or damage the machine.
- Check hitch fit-up frequently. An improper fit-up can cause the attachment to come loose from the loader hitch plate and fall.
- Never carry riders on the machine or its attachments. Riders can obstruct the Operator's view, interfere with control of the machine, be pinched by moving components, become entangled in rotating components, be struck by objects, be thrown or fall from the equipment, etc.

CAUTION

To avoid minor or moderate injury: Keep hands on the machine's control handles or grip bars when in operation. Make sure the pin cover is in place. When the pin cover is in place it will help keep hand from being in an area where it can be pinched while raising loader arms. See Figure 3-33.

IMPORTANT: Never scoop or grade areas while the tilt cylinder is fully extended. Extremely heavy loads apply excessive force to the tilt cylinder and can cause damage.

IMPORTANT: Avoid hitting attachments against rocks or similar solid material, which can damage the attachment or machine.

IMPORTANT: Never fully extend cylinders to perform an operation. Working while cylinders are fully extended can cause damage from excessive force.

IMPORTANT: Never use an attachment in a way it is not intended for. Refer to the attachments Operator's manual.

Section 3: Operating

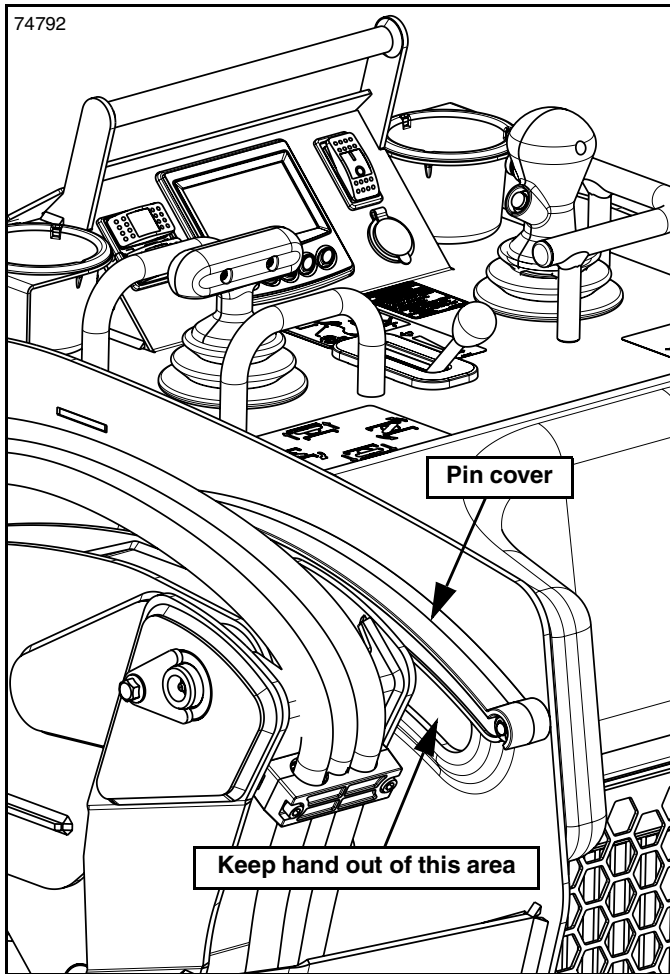

Auxiliary Hydraulics Hook-up
Figure 3-33

- Use caution and check for traffic when approaching and crossing roads and sidewalks.
- Never turn or spin the machine at high speed.
- Always move the machine at speeds that are appropriate to the conditions. Take particular care if you are moving through areas where view may be obstructed by trees, shrubs, etc. or when transporting hazardous material.
- Never back the machine off of obstacles such as curbs or steps, especially with the loader arms raised. Build a ramp with dirt if you will repeatedly encounter these obstacles. See **Figure 3-34**.

IMPORTANT: Running over large debris (rocks, stumps, blocks, etc.) may cause such debris to fly up and damage the machine. Avoid such debris whenever possible.

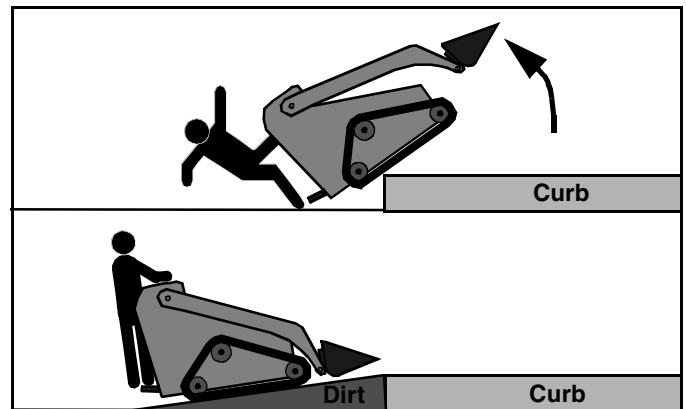

Curb Hazard
Figure 3-34

Precautions While Traveling

! DANGER

To avoid serious injury or death:

Do not drive this machine down public streets or road ways. This machine is not equipped with turn signals, reflective decals or a slow moving vehicle sign. Therefore, this machine is not fit for public streets or road ways.

! WARNING

To avoid serious injury or death:

- If obstacles, such as rocks, stumps and blocks, cannot be avoided, travel slowly over them with the bucket/attachment in the lowered position. Approach the obstacle so it is at the center of the machine to avoid a tipping hazard.
- Whenever traveling over uneven ground surfaces, travel at low speed. Avoid any sudden movements with the machine such as accelerating, stopping, or turning quickly.
- Before backing the machine up, look behind you and look down as well to identify any holes or obstructions. Make sure there are no bystanders around as well. The machine does not make an alert sound when backing-up.

Section 3: Operating

Precaution When Traveling on Inclines

Multiple factors should be considered for safely traveling on inclines. As a rule of thumb, travel with the heavy end up hill. Also consider ground conditions, speed, brake performance, turning, height of load and Operator skill.

DANGER

To avoid serious injury or death:

- Use good judgment when operating on inclines. Various factors and conditions should be considered when determining safe operation on inclines. In general, do not travel on excessively steep slopes under any circumstances.
- Lower the bucket/attachment as low to the ground as possible when traveling on an incline. Lower completely to the ground and stop the machine in case of emergency.
- Always travel at low speed when moving on an incline and avoid turning. Reduce the engine speed (rpm) when moving down an incline. Traveling too fast down an incline can lead to loss of control. Avoid stopping and starting on inclines as it may create a dangerous jerking motion.
- Do not operate near embankments, ditches or drop-offs.
- If the machine begins to tip or lose control, do not try to stabilize the machine by putting your foot on the ground.

WARNING

To avoid serious injury or death:

- Know and understand the machine capabilities and operating conditions, and never exceed any of these conditions. Keep in mind that poor or difficult working conditions may reduce the capability of the machine, requiring a reduction in speed to maintain stability.
- Operate with the heavy end of the machine facing uphill when traveling either direction on a hill. An empty bucket makes the back end of the machine the heavy end, and a full bucket makes the front end the heavy end. See **Figure 3-35**.
- Whenever traveling on an incline, be careful of the possibility of sliding sideways or rolling over.
- Never approach an incline horizontally or diagonally. Always return to a flat surface and redirect the machine.
- Beware of unstable and slippery surfaces such as wet grass, leaves, wet metal or ice. The machine can slide very easily even on low grade inclines.
- Do not hook-up or unhook an attachment on an incline.
- Avoid obstacles such as rocks, tree limbs or ruts when traveling on inclines. Remove obstructions when possible.

Parking on an Incline

NOTE: It is best to park the machine on firm, level ground but if you must park the machine on an incline, adhere to the safety alerts below.

WARNING

To avoid serious injury or death:

- Make sure you chock the machine's tracks to prevent any movement.
- Make sure the machine is highly visible when parking near streets by using barriers, appropriate caution signs, lights, etc. to avoid any accident or collision with other vehicles.
- Never leave the machine running unattended or with the lift arms raised. Whenever the lift arms are raised for maintenance, they **MUST** always be restrained using the lift arm stopper.
- Whenever leaving the machine, perform the proper shut down procedures. Refer to **SCL Shutdown Procedure on page 19**.

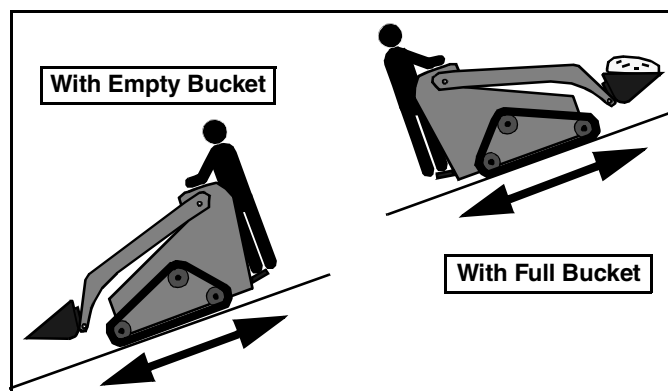

Incline Travel
Figure 3-35

Precautions for Use of Machine Near Water

IMPORTANT: Whenever working near water, pay attention never to allow the machine to become submerged in water above the bottom of the body, especially the rear where the radiator fan could be exposed to water. Always take care to keep working machine parts out of water. See **Figure 3-37**.

IMPORTANT: If parts that require lubrication are exposed to water for long periods of time, make sure they are re-lubricated with grease to remove old grease.

IMPORTANT: Clean the operator platform after working in muddy conditions.

IMPORTANT: Never allow the main body of the machine to become submerged in water or sand. Contact your Kubota dealer if the main body of the machine is exposed to water.

Section 3: Operating

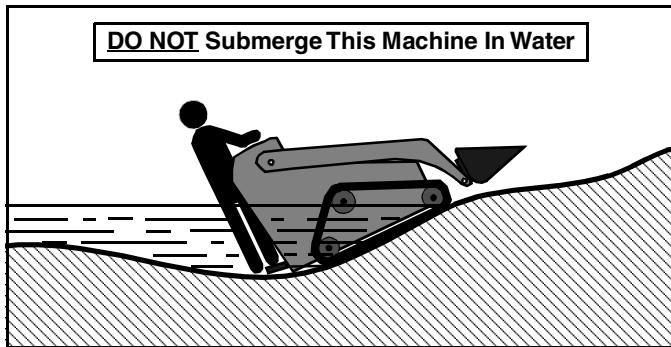

Prohibited Water Depth
Figure 3-37

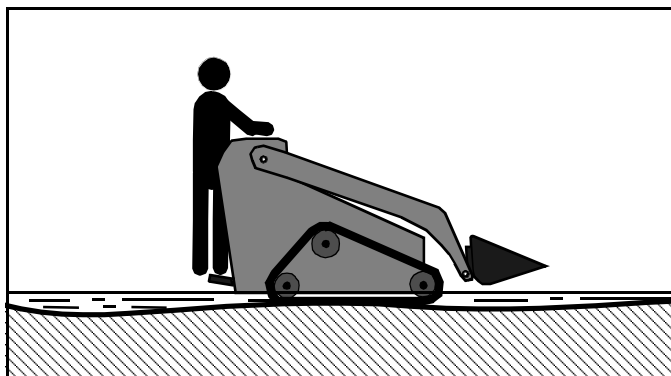

Permissible Water Depth
Figure 3-36

Prohibited Actions



WARNING

To avoid serious injury or death:

- Take care when operating, transporting material or traveling in snowy conditions or on ice as tracks may slip.

IMPORTANT: Always avoid sudden changes in direction, or spinning on concrete surfaces. Excessive friction on the tracks will cause them to wear out or become damaged.

IMPORTANT: Always avoid sudden impact to the tracks such as allowing the machine to drop down or hit objects.

IMPORTANT: Chemicals such as salt, potassium chloride, ammonium sulfate, potassium sulfate, etc., can damage the track belts. If the tracks are exposed to any of these substances, immediately wash thoroughly with water.

IMPORTANT: Avoid scraping the rubber tracks along concrete, and other rough surfaces.

IMPORTANT: Operate machine between -4° F to 113° F (-20° C and +45° C) for proper functioning of rubber track belts.

IMPORTANT: If machine must be stored for 3 months or longer, keep it indoors and out of direct sunlight to prevent UV exposure on rubber or plastic components.

IMPORTANT: Never move, transport material or operate the machine in the following places:
Deep mud, broken stone, jagged or unstable base rock, iron beams, iron scraps, iron sheets, etc. Navigating, turning and moving the machine over sharp material may damage or break the tracks.

IMPORTANT: Do not travel on riverbeds and other areas where loose gravel can get into the tracks, causing them to slip off or become damaged.

IMPORTANT: Do not use near the oceanfront where salt water can corrode the various parts of the machine.

IMPORTANT: Always prevent fuel, oil, salt or other chemical agents from getting on the tracks, which can cause corrosion to the metal track cores. If the track or undercarriage parts are exposed to such material, immediately remove by using water.

IMPORTANT: Always avoid traveling on roads directly after they have been resurfaced or other hot surfaces such as fire or metal surfaces under direct sunlight. Excessive heat can cause irregular wear and damage to tracks.

IMPORTANT: Do not attempt to move material where the surface is unstable and could cause slippage in the tracks. Unnecessary and excessive slipping of tracks will damage and cause abnormal wearing of the tracks.

Preventing Slippage of Rubber Tracks

Always do the following to prevent slippage of rubber tracks:

IMPORTANT: Make sure tracks are kept at the proper tension. Never change directions when there is excessive slack in the track belts.

IMPORTANT: When ascending an incline, never change direction at the base of the incline.

IMPORTANT: Always avoid operating the machine with one track on a different surface than the other track, or with one track partially on an incline. Make sure both tracks are on stable, firm surfaces when in motion.

Operation Under Cold Weather

To get optimal performance out of your machine in cold weather conditions, adhere to the following procedures and notes.

Preparation for Operation In Cold Weather

1. Replace engine oil and hydraulic oil with those of viscosities suitable for cold weather.
2. Drain the fuel tank and use the appropriate fuel for cold weather conditions.
3. In cold weather, battery power drops, and the battery fluid may freeze if the battery is not sufficiently charged. To prevent the battery fluid from freezing, be sure to keep the battery charged at least 80% or more of its capacity after operation. To ease next starting, it is recommended to keep the battery stored in closed or heated room.
4. Add anti-freeze to coolant in the radiator and recovery tank, if the ambient temperature is expected to drop below 32°F (0°C). Mixing ratio of water and anti-freeze depends on the expected ambient temperature. When mixing, stir it up well, and then fill into the radiator.

Mixing ratio between water & anti-freeze								
Ambient temperature								
	°F	+23	+14	+5	-4	-13	-22	-31
	°C	-5	-10	-15	-20	-25	-30	-35
Anti-freeze%		30	30	30	35	40	45	50
Water%		70	70	70	65	60	55	50

- Use permanent anti-freeze or long-life coolant.
- Drain the coolant completely and clean the inside of the radiator, then fill with the water and anti-freeze mixture.
- The anti-freeze acts as an anti-corrosive, it is not necessary to add an additive to the water and antifreeze mixture.
- See “**Fluid Capacities**” on page 68 for radiator fill volumes.
- See “**Starting The Engine**” on page 18.

Procedure After Completion of Work

Clean the machine thoroughly and wipe dry after work has been completed. Mud and dirt on the tracks could freeze if the temperature drops below 32°F (0°C), making it difficult to operate the machine and/or risk costly damage to the machine.

Store the machine in a dry place if possible, otherwise store on wooden planks, mats or on concrete. If the machine is kept on damp or muddy ground, the tracks could freeze overnight, making it difficult to operate the machine and/or risk costly damage to the machine.

Wipe the piston rods, on the hydraulic cylinders, dry. Otherwise severe damage could occur if dirty water seeps through the seals.

This page intentionally left blank.

Transporting the Machine

Transport the machine on a heavy duty truck or trailer that is capable of safely hauling the machine. If transporting the machine on a trailer, make sure the vehicle it is attached to has sufficient power to pull the trailer and machine safely. The truck or trailer should be equipped with a full width ramp that is at least 4 times longer than the height of the truck bed or trailer from the ground (see **Figure 4-1**). Comply with all local ordinances for the trailer and tie-down requirements. Make sure that the truck or trailer has all the required brakes, lights, decals and markings required by local law.

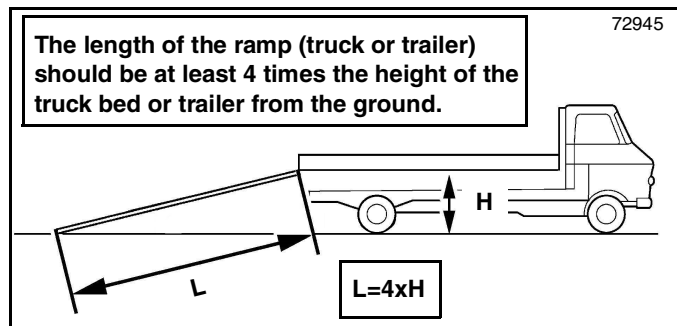

Ramp Specs
Figure 4-1

Loading and Unloading the Machine

DANGER

To avoid serious injury or death:

- Make sure the ramps load capacity is greater than the machine and attachment weight.
- Make sure that the ramp is clean, not damaged and properly attached to the truck or trailer bed.

Loading the Machine

Refer to **Figure 4-2** & **Figure 4-3**:

Use caution when loading the machine onto a truck or trailer as the possibility of losing control or tipping is increased if done carelessly.

DANGER

To avoid serious injury or death:

- Use extreme caution when loading and unloading the machine on a ramp.
- Position the machine so that the heavy end is going up the ramp first.
- Do not accelerate or decelerate suddenly while on the ramp as this will create a jerking motion that increases the possibility of tipping.
- Avoid turning on a ramp. If you must change direction, go back down the ramp and adjust on flat ground.
- When the machine reaches the point between the ramp and the bed, move very slowly until the machine reaches the horizontal position on the bed.

If transporting with a trailer, start with steps 1 & 2. If transporting with a truck, skip to step 3.

1. Hook the trailer up to the vehicle that will haul the machine according to the trailer and vehicle Operator manuals.
2. Connect the trailer's safety chains, lights and the trailer brakes if applicable.
3. Lower the ramp to the ground. Make sure the ramp incline is not greater than 15 degrees from the ground and is at least 4 times longer than the height of the truck bed or trailer from the ground (see **Figure 4-1**).
4. Lower the machine's loader arms down as low as possible without the arms or attachment coming into contact with the ramp.
 - If the machine has no attachment hooked-up to it, the rear end of the machine is the heavy end.
 - If the machine has a material carrying attachment hooked-up to it such as a bucket or pallet fork, but with no load on it, the rear end of the machine is the heavy end.
 - If the machine has a material carrying attachment hooked-up to it such as a bucket or pallet fork, with a full load on it, the front end of the machine is the heavy end.
 - If the machine has an attachment that is not a material carrying attachment such as a powered rake, then the front end is the heavy end.
6. Once the machine is horizontal on the truck or trailer, lower the loader arms all the way down.
7. Shut the machine down. See "**SCL Shutdown Procedure**" on page 19.
8. Secure the machine down to the truck or trailer using chains or straps at the machine's tie-down points. Adhere to all local laws and regulations for tie-down requirements. See **Figure 4-4** & **Figure 4-5**.

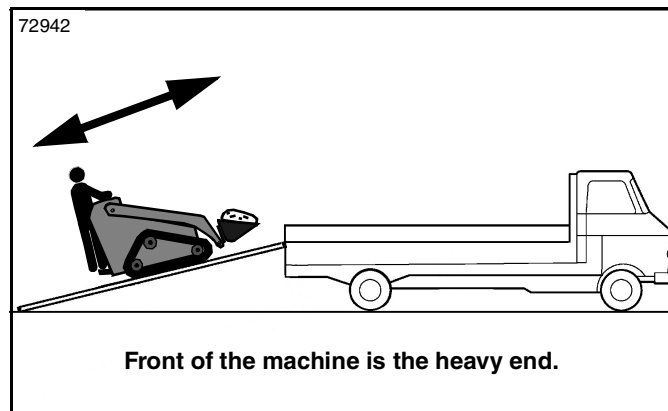

Load & Unload With Heavy Front End
Figure 4-2

Section 4: Transporting

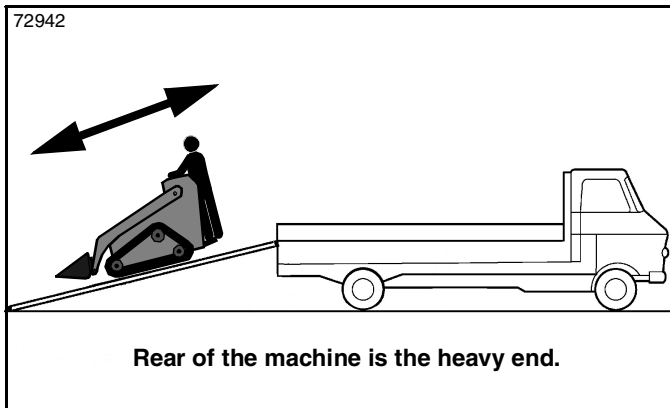

Load & Unload With Heavy Rear End
Figure 4-3

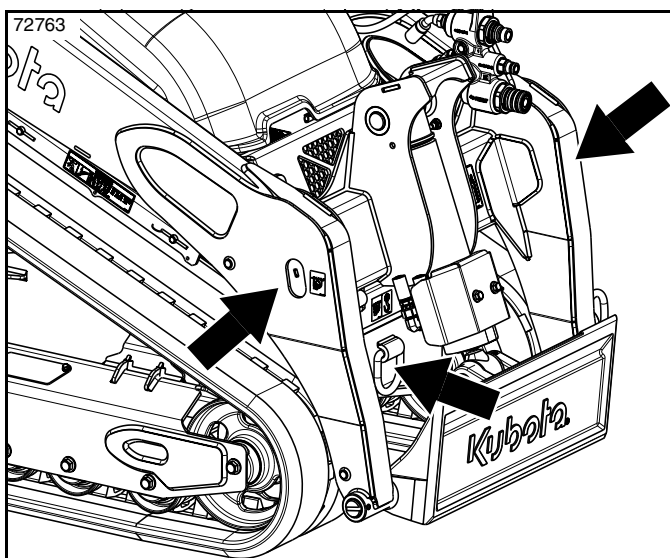

Front Tie-down Points
Figure 4-4

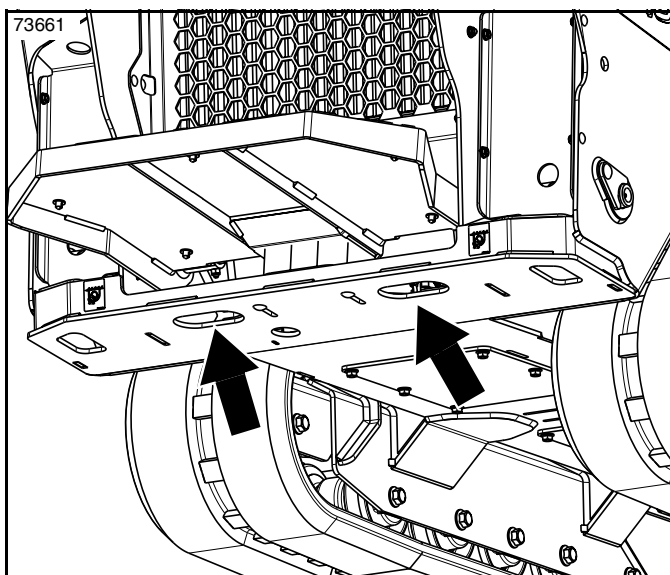

Rear Tie-down Points
Figure 4-5

Unloading the Machine

Refer to Figure 4-2 & Figure 4-3:

Use caution when unloading the machine onto a truck or trailer as the possibility of losing control or tipping is increased if done carelessly.

! DANGER

To avoid serious injury or death:

- Use extreme caution when loading and unloading the machine on a ramp.
 - Do not accelerate or decelerate suddenly while on the ramp as this will create a jerking motion that increases the possibility of tipping.
 - Avoid turning on a ramp. If you must change direction, go back down the ramp and adjust on flat ground.
1. Lower the ramp to the ground. Make sure the ramp incline is not greater than 15 degrees from the ground.
 2. Remove chains or straps used to secure the machine down to the truck or trailer.
 3. Turn the machine on, raise the loader arms and attachment slightly so that they do not come into contact with the ramp.
 4. Unload the machine with the heavy end up the ramp.
 - If the machine has no attachment hooked-up to it, the back end of the machine is the heavy end.
 - If the machine has a material carrying attachment hooked-up to it such as a bucket or pallet fork, but with no load on it, the back end of the machine is the heavy end.
 - If the machine has a material carrying attachment hooked-up to it such as a bucket or pallet fork, with a full load on it, the front end of the machine is the heavy end.
 - If the machine has an attachment that is not a material carrying attachment such as a powered rake, the front end is the heavy end.

Section 4: Transporting

Lifting the Machine

Refer to Figure 4-6 & Figure 4-7:

The machine has lift points that can be used to lift the machine. Read the following safety points and instructions for safely lifting the machine.

DANGER

To avoid serious injury or death:

- Do not lift the machine if it exceeds the maximum rated capacity of the hoist and attaching hardware.
- See specifications for attaching hardware and choose hardware suitable for the weight, size and configuration of the machine.
- Assess the center of gravity of the machine. Lift the machine so that it remains horizontal.
- Do not enter and do not allow others to enter the working area under the suspended machine. Do not move the suspended machine over people.
- Always inspect the attaching hardware (chains, hooks, straps and master links) before each use. Do not use any worn or damaged attaching hardware and do not use if the safety latch is missing.
- Do not use attaching hardware, including chains, hooks and master links, in extreme temperature or other environmental conditions that exceed the manufacturer's specifications.
- Machine disengagement can cause severe injury or death. The use of a hook with a safety latch or other master link device does not preclude inadvertent detachment of a slack sling load from the hook or master link. Visual verification of proper hook or shackle engagement is required in all instances.
- Comply with all Federal, State and Local regulations and safety standards before lifting the machine.
- Make sure the lifting chains, lifting straps, hooks and master links are strong enough to withstand the load being lifted.
- Be sure that the hooks used have safety latches.
- Before lifting, make sure attachments are properly attached to the machine's quick hitch mount plate.

1. Secure chains or lifting straps, that are rated for the weight of the machine, to the lift point locations.
2. Attach the chains or straps to an overhead hoist.
3. Slowly lift the machine only as high as required and move the machine slowly to the desired location.

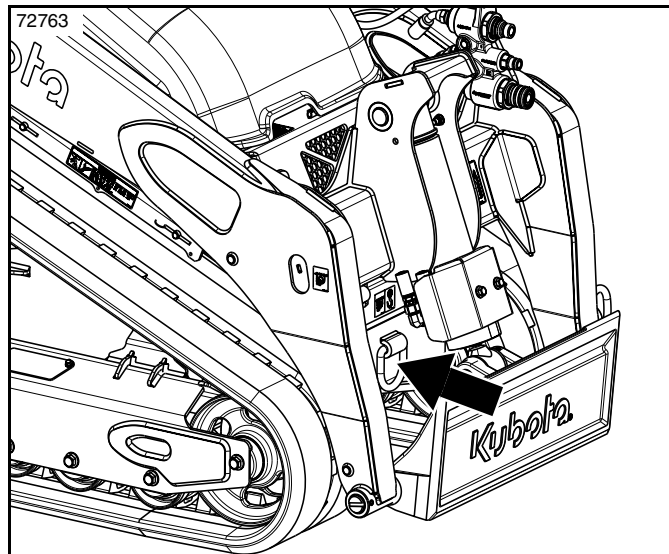

Front Lift Point
Figure 4-6

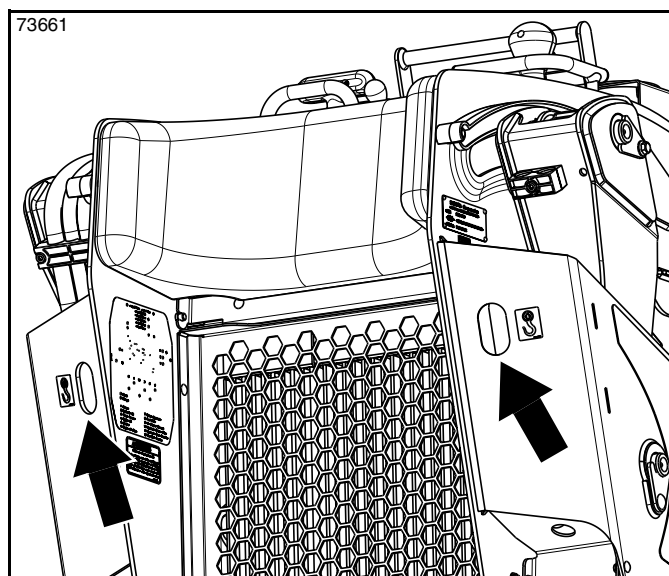

Rear Lift Points
Figure 4-7

Section 4: Transporting

Moving Inoperable Machine

**WARNING**

To avoid serious injury or death:

- Pull the machine only from both rear tie-downs or from front D ring.
- Use a tow chain or tow rope and hardware that is rated at least 1.5 times the machine weight.
- Be aware that when the hydrostats are bypassed, the machine can begin to move if it is not on flat surface.

IMPORTANT: Do not pull the machine without putting the hydrostats into bypass, otherwise damage to the hydraulic drive or track system will occur.

Follow the instructions below for proper procedures for putting the hydrostats into bypass. Contact your Kubota dealer for more information.

IMPORTANT: Do not tow long distances. Tow at a walking speed or at 1-2 mph (1.6-3.2 km/h).

Refer to Figure 4-8:

1. Shut the machine down. See “SCL Shutdown Procedure” on page 19.
2. Open the hood of the machine.
3. Use a wrench or a socket and ratchet to loosen bypass plugs (A & B) on the hydrostat. Do not loosen more than 2 full turns.
4. Disengage the park brake by loosening the retaining bolt and jam nut. Push the park brake in until it clears the drive sprocket.
5. Only use tow chains, ropes or straps that are rated at least 1.5 times the machine weight.

IMPORTANT: The hardware used on the chains, ropes or straps should also be rated at 1.5 times the machines weight.

6. Pull the machine from the rear two tie-down points or from the D-ring located on the front of the machine.
7. Pull the machine at 1-2 mph (1.6-3.2 km/h).
8. Remember to tighten bypass plugs (A & B) when repairs on the machine have been completed.
9. Remember to restore park brake to its original position by pulling it out as far as it can go so that it engages with the sprocket teeth. Tighten the retaining bolt and jam nut.

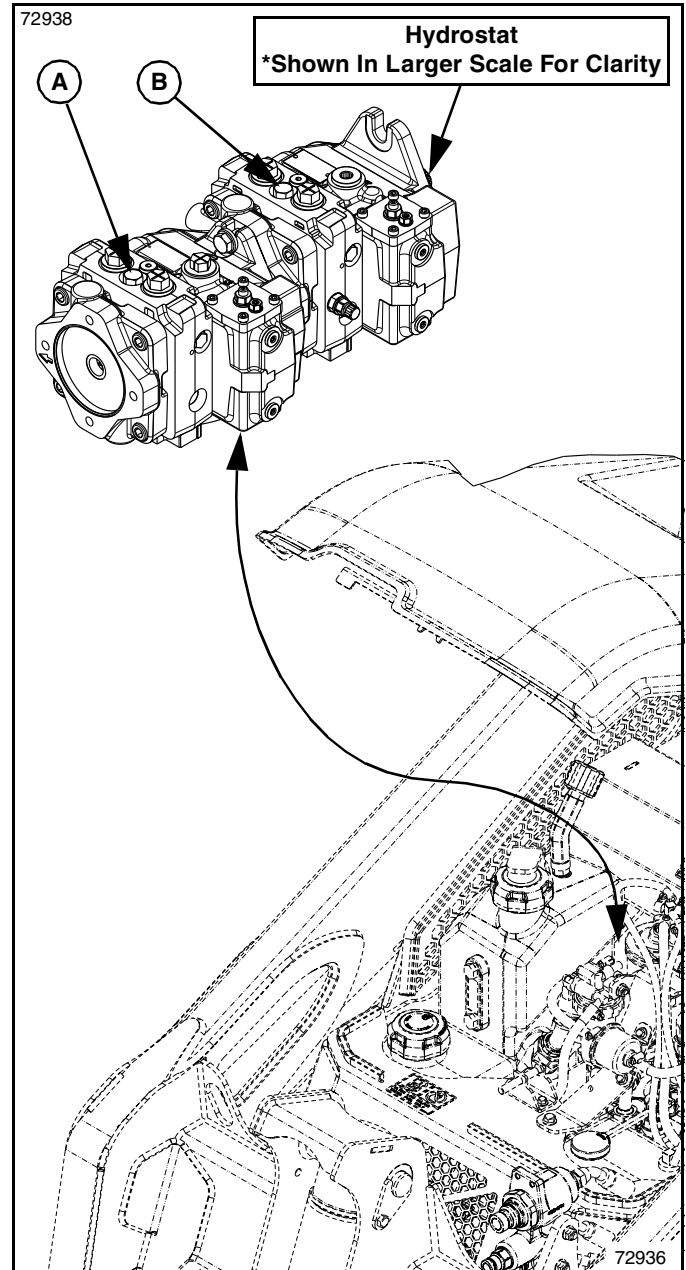

Hydrostat Bypass
Figure 4-8

Maintenance

Regular scheduled maintenance & lubrication is the best prevention for costly downtime and expensive, premature repair. Correct problems as quickly as possible. The following pages contain suggested maintenance information and schedules to follow routinely.

Check initially and periodically for loose bolts and pins. Torque loose bolts per “**Section 9: Torque Values Chart**” on page 76. Visually inspect machine for abnormal wear or damage. Remain alert for unusual noises that could be signaling a problem.

Clear away heavy build-up of grease, oil and dirt, especially around engine and hydraulics. Minute dust particles are especially abrasive to these components.

Some repairs may require the assistance of a trained service mechanic and should not be attempted by unskilled personnel. Consult your Kubota dealer when assistance is needed.

Maintenance Safety



DANGER

To avoid serious injury or death:

- Read and observe all safety warnings in this manual and in all service manuals pertaining to this machine.
- Maintenance procedures should be performed with the machine on a flat, level surface, with the loader arms on the ground and the machine turned off. Use all appropriate personal protective equipment.
- When it is required that the machine be elevated off the ground to perform maintenance, make certain the machine is being hoisted up by a capable hoist and straps. Make sure to use solid, non-concrete blocks or jack stands that are sturdy and are capable of bearing the machine’s weight. Make sure the engine is shut off.
- When maintenance or servicing requires the loader arms to be raised, secure the arms in the raised position with the cylinder lock.
- DO NOT leave engine running when servicing the machine.



WARNING

To avoid serious injury or death:

- Make sure controls are all in neutral position or park before starting the power machine.
- Always keep protective shields on for safety as well as for cleanliness, except when checking or changing components.
- Keep your machine clean. Remove all deposits of grease, oil, dirt, mud and debris, especially from drives, muffler and engine. A dirty machine can cause engine fires and hydraulic overheating.
- Keep the machine properly maintained. Do not make unauthorized modifications. An improperly maintained machine or one that has been improperly modified can be dangerous to operate.

- Keep the machines parts and decals in good condition.
- Do not alter the machine or replace parts on the machine with other brands. Other brands may not fit properly or meet OEM (Original Equipment Manufacturer) specifications. They can weaken the integrity and impair the safety, function, performance, and life of the machine. Replace parts only with genuine OEM parts.
- Keep all hardware tightened. Check for loose hardware periodically.
- When a service or repair requires a technician, never allow untrained and/or unqualified personnel to service or repair the machine.
- Wear protective gloves and safety glasses or goggles when working with hydraulic systems. Hydraulic fluid under pressure can penetrate skin. Use a piece of cardboard or wood rather than hands when searching for hydraulic leaks. If hydraulic fluid is injected into the skin, it must be treated by a doctor within a few hours or gangrene may result.
- Check hydraulic hoses and fittings frequently for leaks or damage. Fluid escaping under pressure can penetrate skin. Large leaks can drop the loader arms. Either situation can cause serious injury or death.
- Allow the machine to cool down before storing it. Do not store the machine near flames.
- When charging the battery, unplug the charger before connecting or disconnecting it from the battery. Charge the battery in open and well ventilated areas.
- Wear all the proper personal protective equipment when handling the battery. Battery acid can cause burns to eyes and exposed skin.
- Keep sparks, flames and cigarettes away from the battery as battery gases can explode.
- Exercise great care and precaution when handling fuel, as it is flammable and its vapors are explosive.
- If an object is struck with the machine, check the machine over and make all necessary repairs before putting the machine back to use.



CAUTION

To avoid minor or moderate injury:

- Do not touch parts that are hot from operation. Allow machine to cool down before attempting to perform maintenance or service.

Maintenance Intervals

Proper lubrication and maintenance directly affects the trouble frequency and service life of the machine. Periodically check and maintain your machine, and you will find that your machine will be in working order and ready to accomplish the tasks at hand in an economic and timely fashion.

Refer to the “**Maintenance Intervals Table**” chart. Adhere to this chart to ensure the longevity of the machine. If the machine is used in harder-than-usual working conditions, it must be checked and maintained at shorter intervals than those listed in the chart.

Maintenance Intervals Table

Check points	Measures	Hours										Intervals	Remarks	Page
		10	50	100	150	200	250	300	350	400	450			
Fuel level	Check	Daily										Daily		50
Water separator	Check	Daily										Daily		51
Hydraulic oil level	Check	o	o	o	o	o	o	o	o	o	o	10 hrs		52
Engine oil level	Check	o	o	o	o	o	o	o	o	o	o	10 hrs		52
Coolant level	Check	o	o	o	o	o	o	o	o	o	o	10 hrs		53
Grease zerks	Grease	o	o	o	o	o	o	o	o	o	o	10 hrs	Every 10 hrs and more frequent as needed	54
Air cleaner element*	Check		o	o	o	o	o	o	o	o	o	50 hrs	Change as needed	54
Track tension	Check		o	o	o	o	o	o	o	o	o	50 hrs	Adjust as needed	55
Fan belt tension	Check		o	o		o		o		o		100 hrs	Check the fan belt EVERY TIME when replacing engine oil/ engine oil filter and adjust if necessary	56
Engine oil	Change		o	o		o		o		o		100 hrs	Change at 50 hrs then every 100 hrs after	56
Engine oil filter	Change		o	o		o		o		o		100 hrs	Change at 50 hrs then every 100 hrs after	58
Fan belt adjustment	Adjust					o				o		200 hrs	Adjust every 200 hrs as needed	59
Air cleaner element*	Change						o				o	250 hrs	Clean as needed	60
Fuel filter	Change						o				o	250 hrs		61
Hydraulic return filter	Change		o				o				o	250 hrs	Change at 50 hrs then every 250 hrs after	62
Hydraulic oil	Change										o	500 hrs		63
Hydraulic tank breather	Change	Every year										1 year		64
Coolant	Change	Every 2 years										2 years		64

*Clean and replace the air cleaner element more frequently if machine is being used in dusty conditions. If the air filter is extremely dirty due to dusty conditions, replace it.

Pre-maintenance Procedures

The following are pre-maintenance procedures that the Operator or technician can refer back to before beginning the maintenance service. These procedures are to be done while the machine is turned off.

Opening & Closing the Waist Cushion

Refer to Figure 5-1 & Figure 5-2:

To Open the Waist Cushion

1. Pull on cable release lever (#1) and pull back on the top of waist cushion (#2) rotating it open.
2. **This step is optional.** With waist cushion (#2) rotated down, lift upward on it to remove it completely.

To Close the Waist Cushion

NOTE: Check to make sure the pull knob is pushed all the way in before closing the waist cushion to ensure proper latching.

1. **This step is only if the cushion was removed.** Re-attach waist cushion (#2) to pivot studs (#3).
2. Rotate waist cushion (#2) up.
3. Press on the upper middle of waist cushion (#2) until you hear it latch.

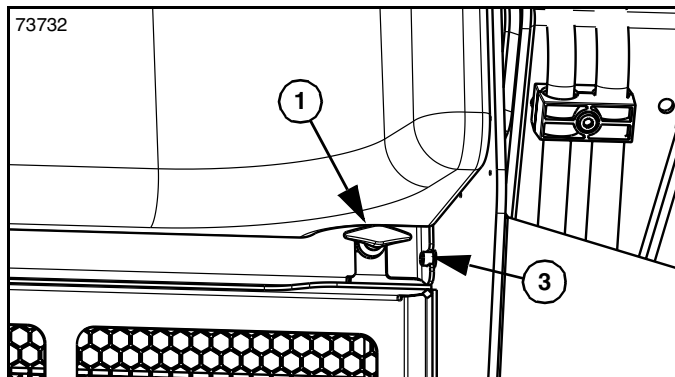

Release Lever
Figure 5-1

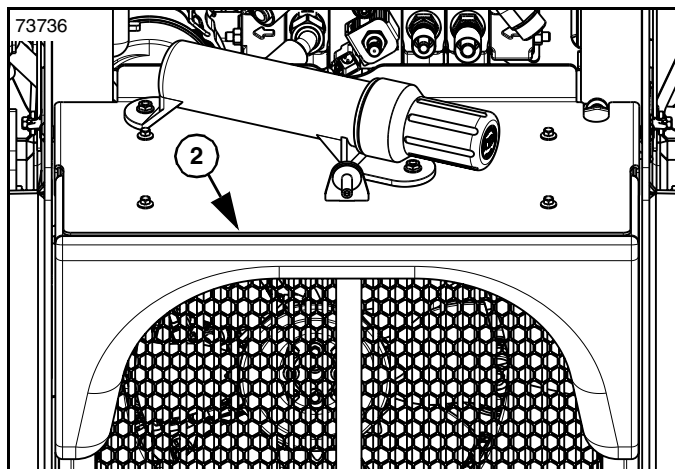

Open Waist Cushion
Figure 5-2

Opening & Closing the Control Panel

Refer to Figure 5-1 & Figure 5-3:

To Open the Control Panel

1. With waist cushion down/removed, press up on release lever (#5) and lift control panel (#4). A gas shock will hold control panel (#4) open when raised all the way up.

To Close the Control Panel

1. Pull down on control panel (#4) and press down on it until it latches.

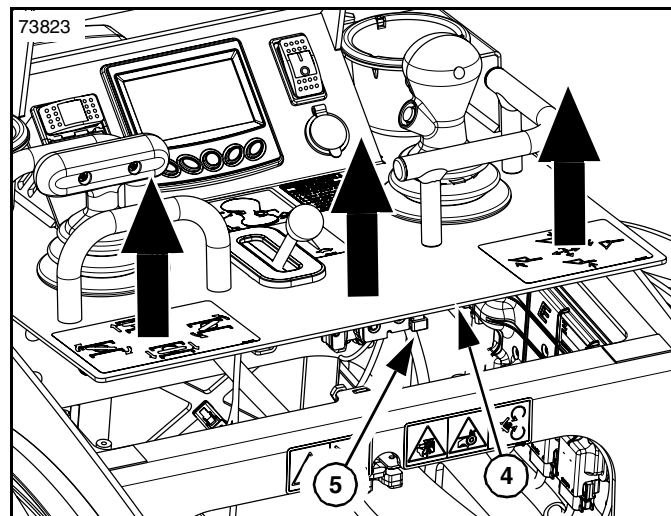

Open Control Panel
Figure 5-3

Opening & Closing the Hood

Refer to Figure 5-4 & Figure 5-5:

To Open the Hood

1. Locate hood latch under hood (#1) and pull forward.
2. Lift upward on hood (#1). Gas shock (#2) will hold hood (#1) open in place.

To Close the Hood

1. Pull down on hood (#1) and press down until you hear it latch.

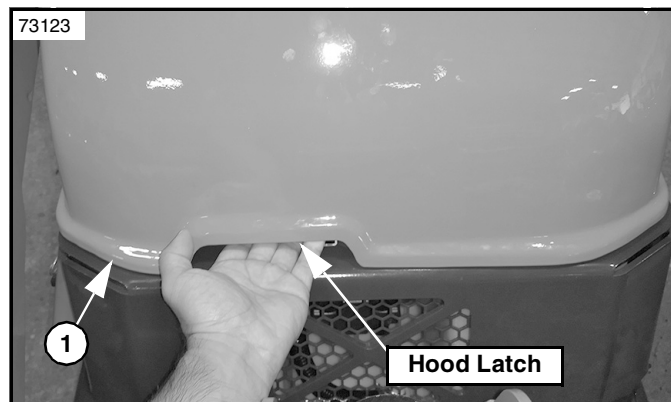

Hood Latch
Figure 5-4

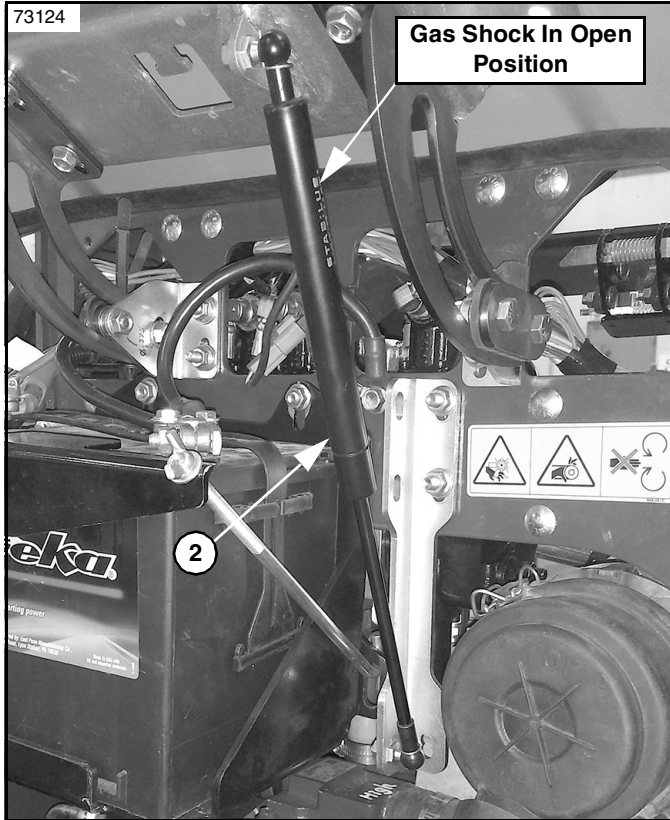

Hood Gas Shock
Figure 5-5

Apply Cylinder Lock

Refer to Figure 5-6 & Figure 5-7:

To Install Cylinder Lock

1. From the operator platform, raise the loader arms all the way up.
2. Turn the machine off. See “SCL Shutdown Procedure” on page 19.
3. Pull detent pins (A & B).
4. Remove cylinder lock (#1) from storage location.
5. Install cylinder lock (#1) onto the fully extended hydraulic cylinder rod with the curved end on the cylinder rod knuckle as shown in **Figure 5-7**. Put detent pins (A & B) through holes in cylinder lock (#1) to secure it as shown in **Figure 5-7**.

To Remove Cylinder Lock

1. From the operator platform, raise the loader arms all the way up to ensure that the loader arms are not resting on cylinder lock (#1).
2. Turn the machine off. See “SCL Shutdown Procedure” on page 19.
3. Pull detent pins (A & B) from cylinder lock (#1).
4. Remove cylinder lock (#1).
5. Re-assemble cylinder lock (#1) to its storage location. Secure with detent pins (A & B) as shown in **Figure 5-6**.

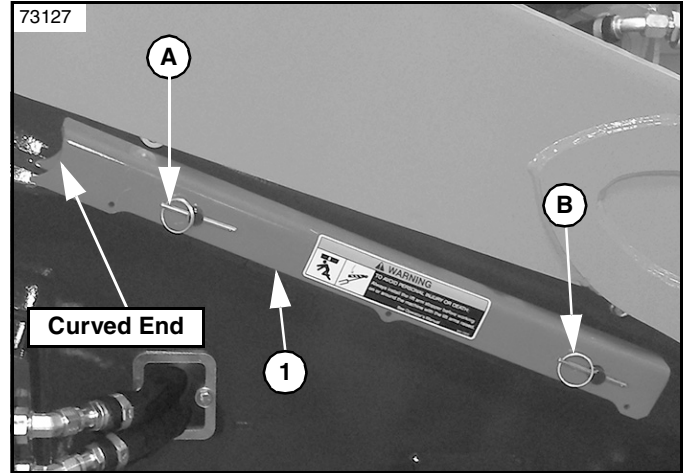

Cylinder Lock Storage Position
Figure 5-6

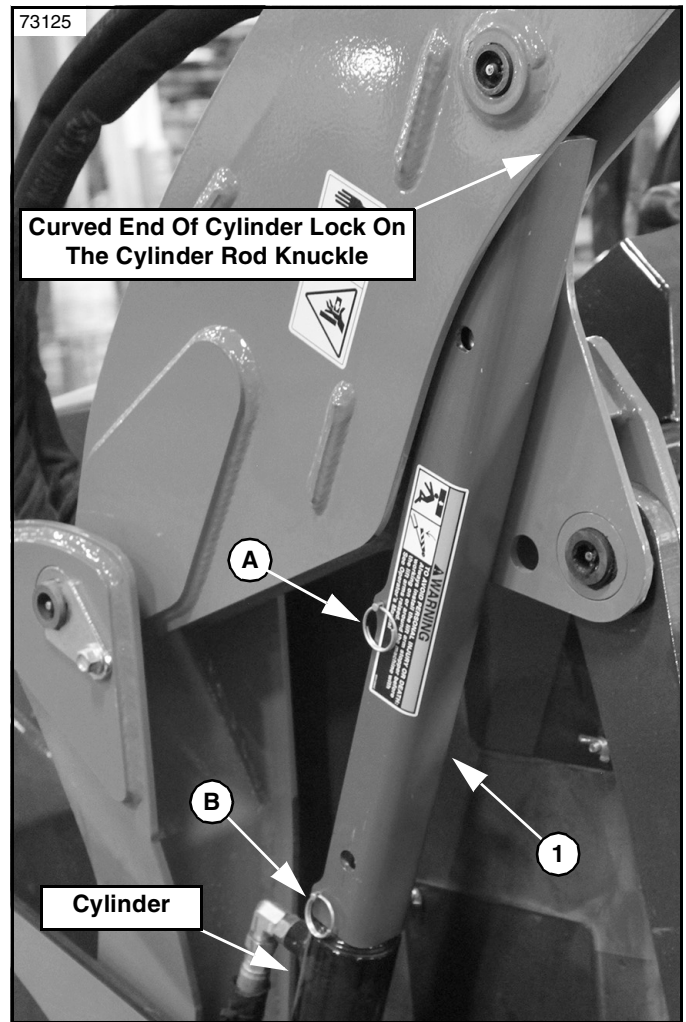

Cylinder Lock On Cylinder Rod
Figure 5-7

Daily Checks/Every 10 Hours

For your own safety and to assure the long life of your machine, the following checks should be performed before each use of the machine and/or every 10 hours.

Checking & Adding Fuel

WARNING

To avoid serious injury or death:

The following procedure should be performed with the machine on a flat, level surface, the loader arms completely lowered and the machine turned off. Use all the appropriate personal protective equipment when performing maintenance.

Use extreme caution when handling fuel as it is flammable and its vapors are explosive. Adhere to the following safety alerts and instructions when adding fuel to the machine.

DANGER

To avoid serious injury or death:

- Replacement of fuel system parts (i.e. gas caps, hoses, fuel tank, fuel filter, etc.) must be the same as original parts. Fire and/or explosion can occur if not followed.
- Observe safe fuel handling precautions. Fuel is flammable and vapors are very explosive. An explosion or fire can burn, destroy and kill property, animals and people.
- Do not fill tank with engine running or while engine is hot. Allow engine to cool before filling. Fuel spilled over engine, muffler, or hot objects may result in a fire or explosion.
- Do not smoke while handling fuel or around the fuel tank.
- Keep fuel away from open flame or spark.
- Store the machine away from open flame and sparks.
- Refuel outdoors preferably, or in well ventilated areas.
- Never attempt to start the engine when there is a strong odor of fuel fumes present. Locate and correct the cause.
- Do not fill fuel containers inside of a vehicle, on a truck, or on a trailer. Interior carpets and plastic truck bed liners insulate the container and slow loss of static charge.
- When practical, unload the machine from the truck or trailer and refuel the machine with its tracks on the ground. If this is not possible, then refuel the machine on the truck or trailer using a portable container and not a fuel dispenser nozzle. If a fuel dispenser nozzle must be used, keep the nozzle in contact with the rim of the fuel tank or container opening at all times until fueling is complete.
- Fuel is a poison that is harmful or fatal if swallowed.

WARNING

To avoid serious injury or death:

- Allow engine to cool before servicing the fuel system.
- Do not fill fuel tank to the top. Fuel will expand in hot weather and seep out through the fuel tank vent system.

- Screw the fuel cap on tight immediately after filling the fuel tank. Never operate the machine without a fuel cap.
- Clean up any fuel spills immediately.
- Avoid prolonged breathing of fuel vapors. Long-term exposure to fuel vapors can cause serious injury and illness.
- Keep face away from nozzle and fuel tank opening.
- Keep fuel away from eyes and skin.

IMPORTANT: Never buy more than a 30 day supply of fuel. Store fuel in an approved container out of children's reach.

IMPORTANT: Use diesel fuel only. Using other fuels such as gasoline will damage the machine's engine.

IMPORTANT: Be aware of the fuel level in the fuel tank so that the machine will not run empty. The machine's fuel system or engine can be damaged.

IMPORTANT: To prevent condensation (water) accumulations in the fuel tank, fill the fuel tank full before parking overnight.

IMPORTANT: For optimal machine performance, when temperatures are above -5 C(+23 F), use No.2- D diesel fuel. When temperatures are under -5 C(+23 F), use No.1-D diesel fuel.

IMPORTANT: The minimum cetane rating for the appropriate diesel fuel should be at least 40.

IMPORTANT: Do not pour fuel into hydraulic tank.

Refer to Figure 5-8:

1. Check the fuel gauge on the monitor and add fuel as needed.
2. Open the machine's hood. See "Opening & Closing the Hood" on page 48.
3. Remove fuel cap (#1) and add fuel. Make sure to keep the fuel dispenser nozzle in constant contact with the rim of the fuel tank while adding fuel.
4. Twist fuel cap (#1) back on until it clicks once.

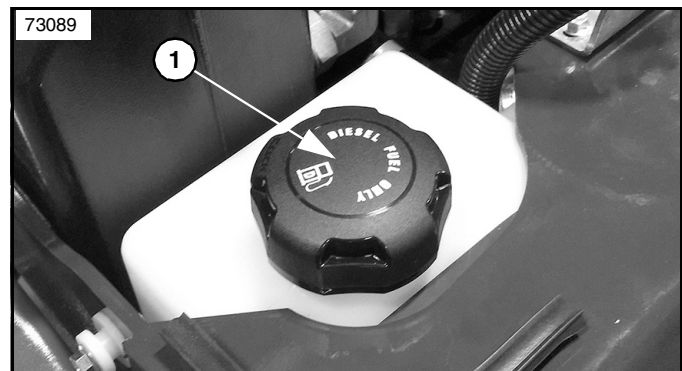

Fuel Cap
Figure 5-8

Check the Water Separator

WARNING

To avoid serious injury or death:

The following procedure should be performed with the machine on a flat, level surface, the loader arms completely lowered and the machine turned off. Use all the appropriate personal protective equipment when performing maintenance.

When the separated water is entering the sediment cup, the red float in the cup moves upward. If the float is at or above the white “drain water” line on the cup, follow the steps below for dumping the water out.

Refer to Figure 5-9 & Figure 5-10:

1. Open the machine’s hood. See “Opening & Closing the Hood” on page 48.
2. Close the shutoff-valve (#1) on the water separator assembly so that no fuel can run out. (Shut off valve shown in the off position in **Figure 5-9**.)
3. Unscrew the sediment cup collar (#2) to remove the cup (#3) from the water separator assembly.
4. Dump the water from the sediment cup (#3).

IMPORTANT: Be careful when dumping the water from the cup, not to lose the float and spring that is inside the cup.

5. Reassemble the sediment cup (#3) to the water separator assembly by screwing the cup back on with the sediment cup collar (#2). Hand tighten.
6. Turn the shutoff-valve (#1) back to its original position.

IMPORTANT: In reattaching the sediment cup, be careful to keep dust and dirt away from the inside of the sediment cup.

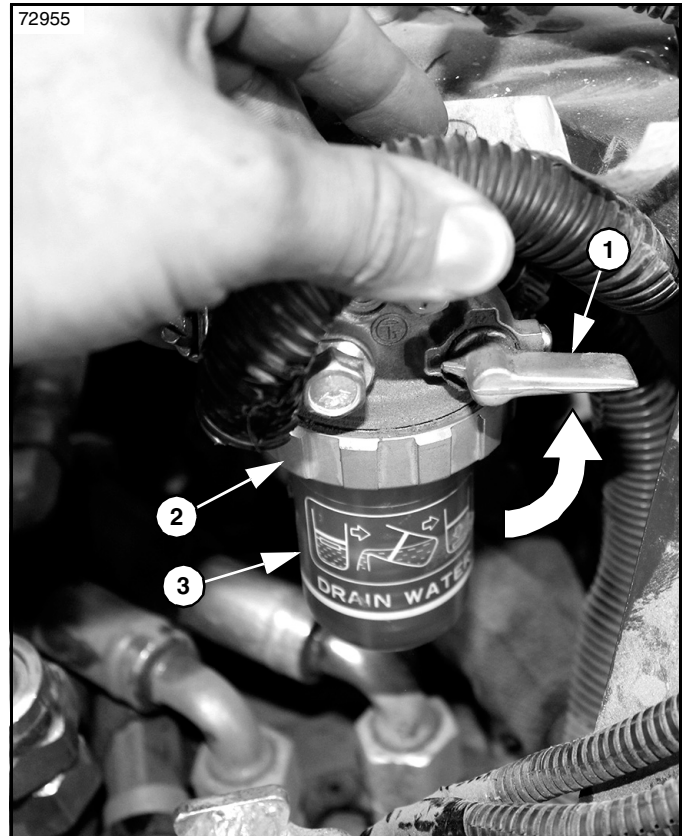

Water Separator Check
Figure 5-9



Sediment Cup Drain Line
Figure 5-10

Check Hydraulic Oil Level

WARNING

To avoid serious injury or death:

The following procedure should be performed with the machine on a flat, level surface, the loader arms completely lowered and the machine turned off. Use all the appropriate personal protective equipment when performing maintenance.

Refer to Figure 5-11:

1. Open the machine's hood. See "Opening & Closing the Hood" on page 48.
2. Check oil level sight (#1) when oil temperatures are between 50°F and 86°F (10°C and 30°C). The loader arms must be down all the way and the curl cylinder fully retracted to determine an accurate hydraulic oil level reading. The oil level should be at or near the middle of oil level sight (#1).
3. If oil level is too low, remove hydraulic cap lock (#5) by removing 3/8-16 X 3/4 GR5 flanged bolt (#6). Remove dust and dirt from hydraulic oil tank (#4) and hydraulic oil tank cap (#3).
4. Remove hydraulic oil tank cap (#3) and add hydraulic oil up to the middle of oil level sight (#1). It is important for the protection of the hydraulic system to only use the recommended hydraulic oil. See "Recommended Fluids" on page 69.
5. Twist oil cap (#3) back on until it clicks once, then replace hydraulic cap lock (#5) with 3/8-16 X 3/4 GR5 flanged bolt (#6).
6. Allow machine to idle for 1 minute before operating any hydraulics to allow the hydraulic oil to be filtered before reaching any contamination-sensitive areas.

IMPORTANT: Always use the correct hydraulic oil. Using the wrong hydraulic oil can result in damage to the hydraulic system.

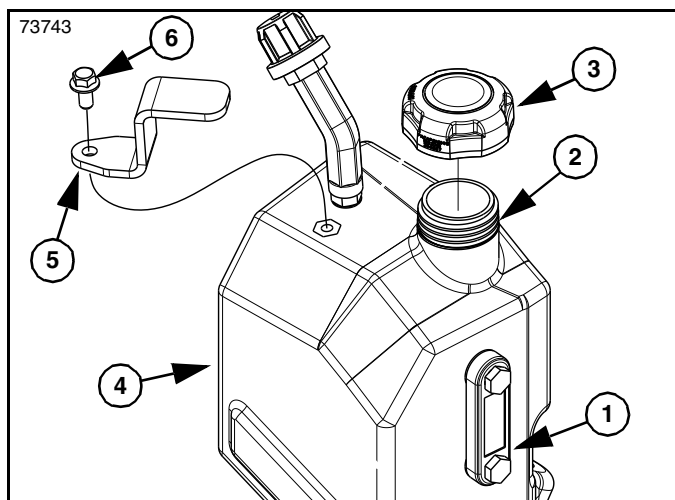

Hydraulic Oil Level Check
Figure 5-11

Check Engine Oil Level

WARNING

To avoid serious injury or death:

The following procedure should be performed with the machine on a flat, level surface, the loader arms completely lowered and the machine turned off. Use all the appropriate personal protective equipment when performing maintenance.

Refer to Figure 5-12 & Figure 5-13

NOTE: For better accuracy, allow for the machine to cool down sufficiently if it has been in operation.

1. Open the machine's hood. See "Opening & Closing the Hood" on page 48.
2. Wipe off dirt and dust from around dipstick (#1).
3. Pull out dipstick (#1), wipe it clean with a clean rag then put it back in and push it all the way in. Pull dipstick (#1) out again and check to see if the oil level lies between holes (A & B). See Figure 5-13.
4. If oil level is below hole (B), add new oil by removing oil cap (#2) and pouring oil into the oil filling port with a clean oil funnel. See "Recommended Fluids" on page 69 for the correct engine oil.
5. Repeat steps 3 & 4 until the oil level is between holes (A & B).
6. Replace oil cap (#2) and dipstick (#1) when finished.

IMPORTANT: Keep oil level between holes (A & B). To avoid damage to the machine, do not over fill or operate with low oil. Use the correct engine oil with the correct viscosity for outside temperatures. See "Recommended Fluids" on page 69.

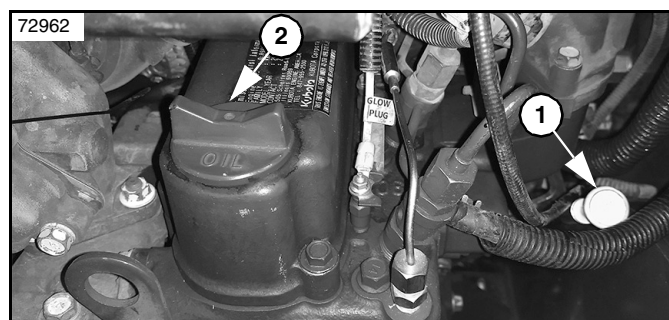

Oil Cap
Figure 5-12

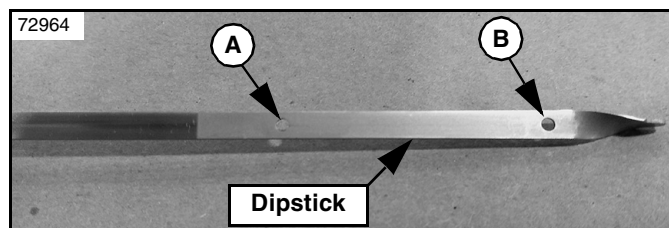

Dipstick
Figure 5-13

Check Coolant Level

WARNING

To avoid serious injury or death:

The following procedure should be performed with the machine on a flat, level surface, the loader arms completely lowered and the machine turned off. Use all the appropriate personal protective equipment when performing maintenance.

Refer to Figure 5-14:

NOTE: For better accuracy, allow for the machine to cool down sufficiently if it has been in operation.

1. Open the waist cushion. See “Opening & Closing the Waist Cushion” on page 48.
2. Check to see that the coolant level is between the “FULL” and “LOW” marks of recovery tank (#1).
3. If coolant needs to be added to recovery tank (#1), open up the control panel. See “Opening & Closing the Control Panel” on page 48. Remove recovery tank lid (#2). Use a clean funnel if necessary.

NOTE: Coolant may evaporate over a long period of time. However, if coolant level goes down significantly in a short period of time, it is likely because of one of the following:

- **Improper refill** in which bubbles that are not bled out initially have worked their way up to the recovery tank and coolant has sufficiently resupplied the radiator to fill the voids.
- **Leaks** should be identified and fixed immediately.
- **Overheating** in which the coolant has expanded enough to fill the recovery tank and even overflow out of the overflow hose. When everything cools down, the coolant level in the recovery tank draws back down, possibly below the “low” line on the recovery tank. In this case the overheating problem needs to be fixed immediately.

- When the coolant level drops due to evaporation, add water only up to the full level.
- In case of leakage, add anti-freeze and water in the specified mixing ratio up to the full level.

IMPORTANT: Do not over fill the recovery tank. Fill only to the “FULL” line on the tank.

IMPORTANT: Do not fill the recovery tank with dirty or salty water.

4. Replace recovery tank lid (#2).

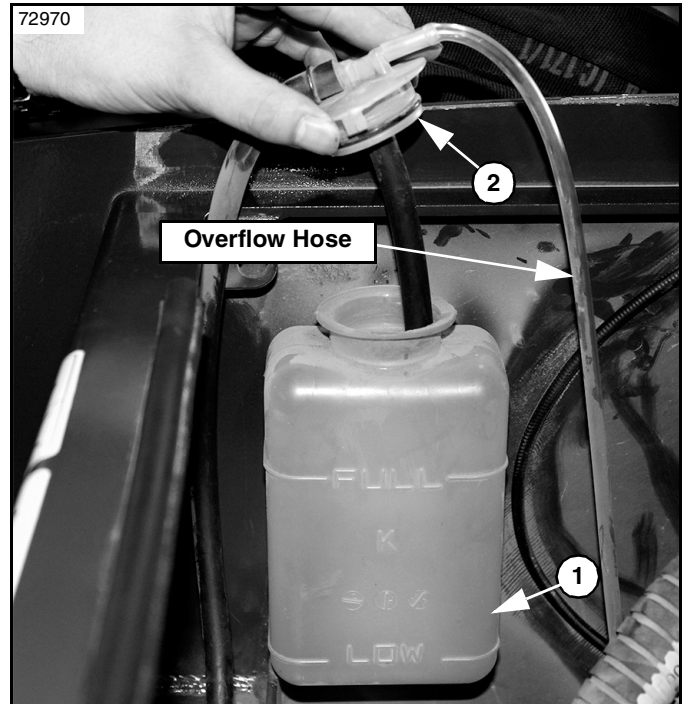

Coolant Level Fill
Figure 5-14

Check Grease Points

WARNING

To avoid serious injury or death:

The following procedure should be performed with the machine on a flat, level surface, the loader arms completely lowered and the machine turned off.

Refer to “Lubrication Points” on page 70

In general, the machine should be greased daily. It is also good practice to grease the machine immediately after it has been washed and at the end of the day if it has been exposed to water while operating.

1. Locate the machine’s grease zerks and wipe them clean with a rag. See “Lubrication Points” on page 70 for grease zerk locations.

IMPORTANT: Replace missing or damaged grease zerks immediately.

2. One by one, with a grease gun, pump grease into the grease zerks until you see excess grease ooze out (Typically 3-4 pumps).
3. Wipe away excess grease with a rag.

Every 50 Hours

For your own safety and to assure the long life of your machine, the following checks should be performed every 50 hours.

Check Air Cleaner Element

WARNING

To avoid serious injury or death:

The following procedure should be performed with the machine on a flat, level surface, the loader arms completely lowered and the machine turned off. Use all the appropriate personal protective equipment when performing maintenance.

IMPORTANT: If the machine is used in dusty conditions for several hours, checking the air cleaner element should be done more frequently.

Refer to Figure 5-15 & Figure 5-16:

1. Open the machine's hood. See "Opening & Closing the Hood" on page 48.
2. Place a container below evacuator valve (#2) then pinch evacuator valve (#2) so that the slit opens up to empty any dust into the container. Discard the dust.
3. Release latches (A & B) on air cleaner cover (#1) and remove air cleaner cover (#1).
4. Clean the inside of air cleaner cover (#1) with compressed air.
5. Clean the evacuator valve (#2) by pinching it together so that the slit opens up then blow compressed air through it from the back.

IMPORTANT: Do not clean the inside of the air cleaner body with compressed air.

Do not remove the inner element filter to clean the air cleaner body.

6. Remove outer element filter (#3) and clean inside of the air cleaner body with a damp paper towel or rag.
7. Check outer element filter (#3). If it needs cleaned, blow compressed air through it from the inside of the filter as shown in Figure 5-17.
8. Reinstall outer element filter (#3) in the air cleaner body. Press it in firmly.
9. Fasten the air cleaner cover (#1) to the air cleaner body as shown in Figure 5-15 with the evacuator valve (#2) pointing down.
10. Check the air cleaner body and cover (#1) for any damage that may cause air leaks and replace any damaged components immediately.

IMPORTANT: Do not operate the machine with a damaged air cleaner system. If any part of the air cleaner body or cover is cracked or damaged, replace the damaged parts before operating the machine. Never operate machine without its filters.

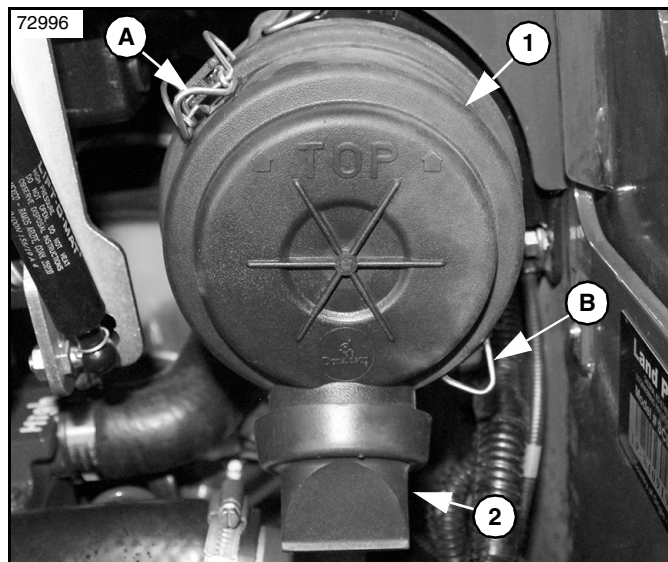

Air Cleaner
Figure 5-15

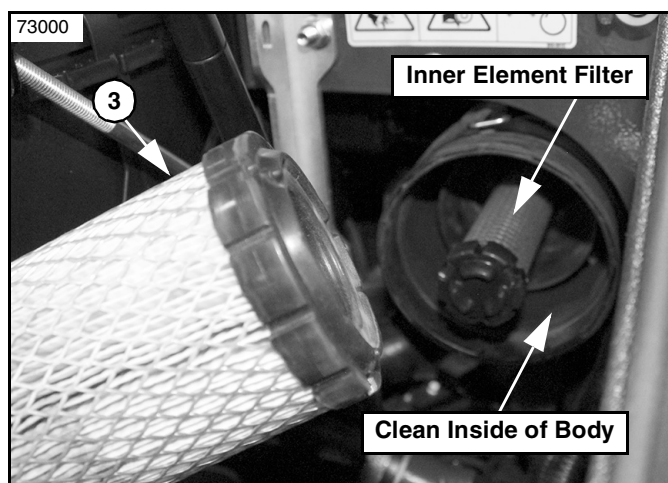

Filter Elements
Figure 5-16

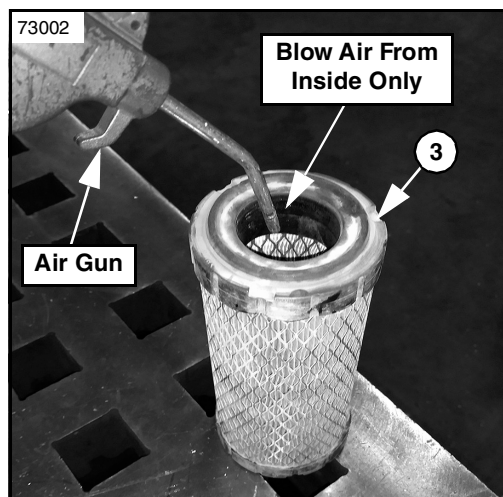

Outer Element Filter Cleaning
Figure 5-17

Check Track Tension

WARNING

To avoid serious injury or death:

The following procedure should be performed with the machine on a flat, level surface, the loader arms completely lowered and the machine turned off. Use all the appropriate personal protective equipment when performing maintenance.

To check the track tension you will need a flat bar or a level and a tape measure. The proper sag in the track should measure 1/4" from the top of the track to the bottom of the flat bar or level.

Refer to Figure 5-18:

1. Lay a flat bar or a level on the track.
2. Measure the of sag in the middle of the track with a tape measure.

If the sag is more than 1/4" then the track needs to be adjusted tighter.

Refer to Figure 5-19:

- a. Loosen bolts (A & B) and rotate grease cylinder cover plate (#1) open.
- b. Wipe grease zerk (#2) clean with a rag.
- c. Use a grease gun to pump grease into grease zerk (#2) until the sag in the track measures 1/4".
- d. Rotate cover plate (#1) back into its original position and tighten bolts (A & B).

If the sag is less than 1/4" then the track needs to be adjusted looser.

Refer to Figure 5-19:

- a. Loosen bolts (A & B) and rotate grease cylinder cover plate (#1) open.
- b. Wipe grease zerk (#3) clean with a rag.
- c. To release pressure on the track, use a 7/16" wrench to turn grease zerk (#3) counterclockwise a quarter turn.

NOTE: A straw or small hose can be placed over the grease zerk to redirect grease and limit the mess.

WARNING

To avoid serious injury or death:

Track adjuster grease is under high pressure. Be cautious not to remove the grease zerk completely, as the pressure could shoot the zerk out at a high velocity.

- d. Re-tighten grease zerk (#3) a quarter turn when a 1/4" sag in the track is achieved.
 - e. Rotate cover plate (#1) back into its original position and tighten bolts (A & B).
3. Repeat as needed for the other track.

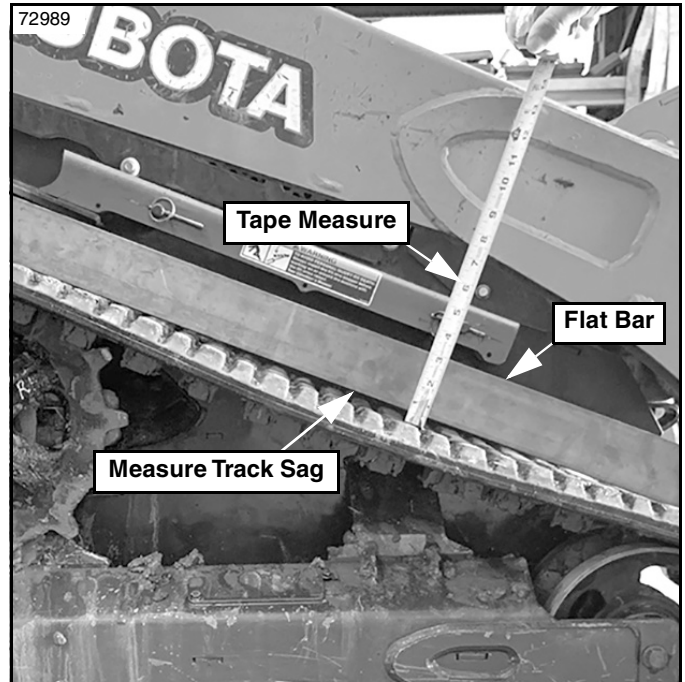

Track Sag Measurement
Figure 5-18

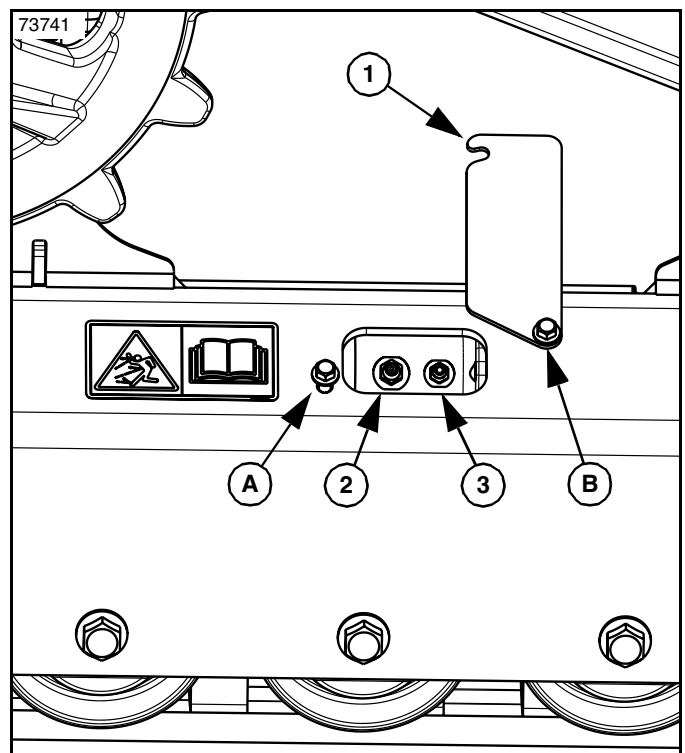

Track Tension Adjustment
Figure 5-19

Every 100 Hours

For your own safety and to assure the long life of your machine, the following maintenance should be performed every 100 hours.

Check Fan Belt Tension

WARNING

To avoid serious injury or death:

The following procedure should be performed with the machine on a flat, level surface, the loader arms completely lowered and the machine turned off. Use all the appropriate personal protective equipment when performing maintenance.

NOTE: Fan belt tension should be checked and tightened, if needed, when changing the oil filter as it will be easier while the filter access cover is off.

Refer to Figure 5-20:

1. Remove oil filter access cover (#1) by removing bolt (#2) with a ratchet and a 9/16" socket. Set cover (#1) off to the side.

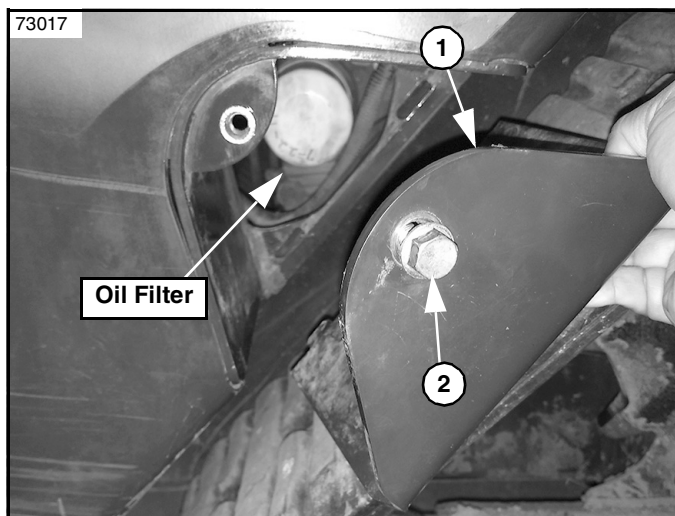

Oil Filter Cover Removal
Figure 5-20

Refer to Figure 5-21:

2. With a tension checker, apply force to the fan belt between the fan drive pulley and the alternator pulley.
3. Measure the deflection.

Refer to Figure 5-22:

4. If the measurement is out of the service specifications, loosen the top alternator mounting bolt (#3) and adjust the fan belt tension.

NOTE:

- Pivoting the alternator closer to engine will loosen the fan belt tension.
- Pivoting the alternator away from the engine will tighten the fan belt tension.

5. Tighten the top alternator mounting bolt (#3) to the alternator after adjusting the fan belt tension.

Service Specification	
Deflection	7.0 to 9.0 mm 0.28 to 0.35 in. (Under load of 98 N-m or 22 lbf)

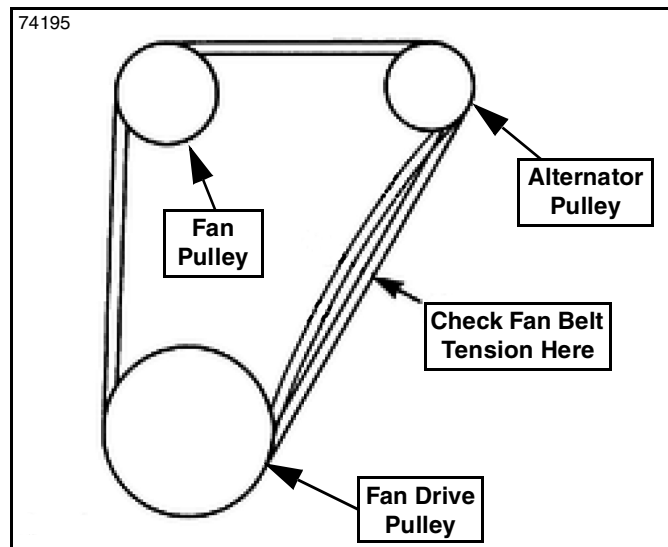

Fan Belt & Pulleys
Figure 5-21

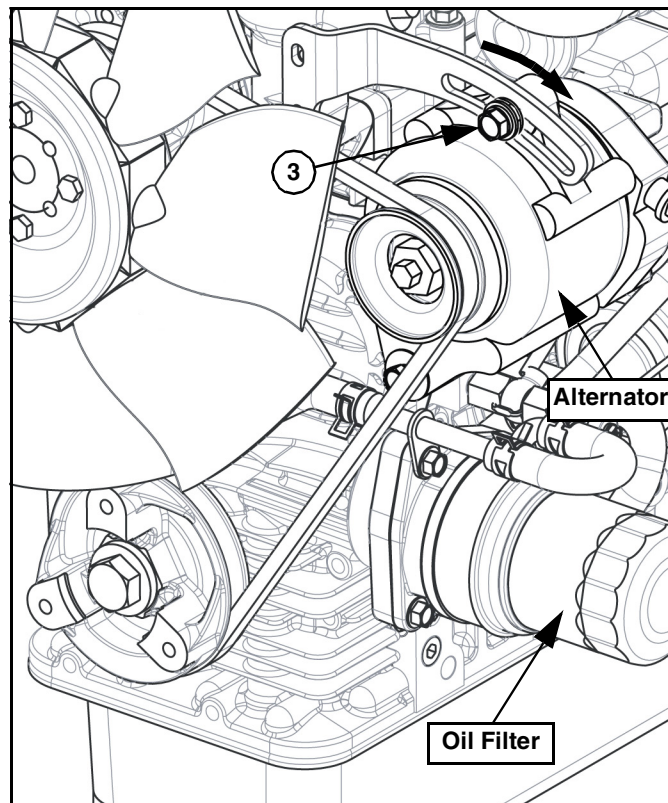

Fan Belt Tensioning
Figure 5-22

Change the Engine Oil

WARNING

To avoid serious injury or death:

The following procedure should be performed with the machine on a flat, level surface, the loader arms completely lowered and the machine turned off. Use all the appropriate personal protective equipment when performing maintenance.

Refer to **Figure 5-24** & **Figure 5-25**:

1. Lift up operator platform (#1).
2. Place an oil pan, or something similar, underneath the machine to catch the oil that will be drained.
3. Open oil drain valve (#2) to drain the oil by turning the handle counter clockwise.
4. Once the oil is fully drained, close oil drain valve (#2).
5. Replace the oil filter before proceeding. See “**Change the Oil Filter**” on page 58.

IMPORTANT: Change oil filter with each oil change.

6. Open the machine’s hood. See “**Opening & Closing the Hood**” on page 48.
7. Wipe away dirt and dust from around oil fill cap (#3).
8. Remove the oil fill cap (#3).
9. With a clean funnel, pour new oil, approximately 3/4 of the specified capacity, into the oil reservoir. See “**Fluid Capacities**” on page 68.

IMPORTANT: Use recommended oil only. See “**Recommended Fluids**” on page 69.

10. Check the oil level with dipstick (#4).
11. Replace dipstick (#4) and continue to add oil slowly until the oil level is to upper hole (A) in the dipstick. See **Figure 5-23**. Replace oil cap (#3).

IMPORTANT: Do not overfill with oil over the engine’s capacity of 4 QT (3.8L).

12. Turn the machine on for a few minutes to allow the oil to flow through the system and into the new oil filter.
13. Check the oil level again and add oil as needed.
14. Properly dispose of used waste.

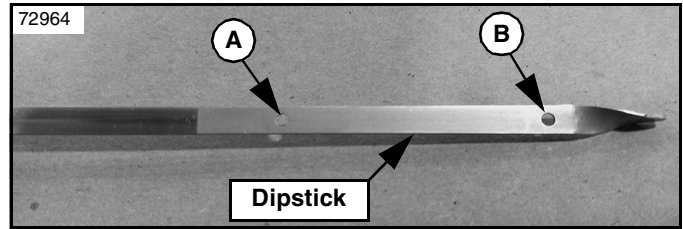

Engine Oil Level Check
Figure 5-23

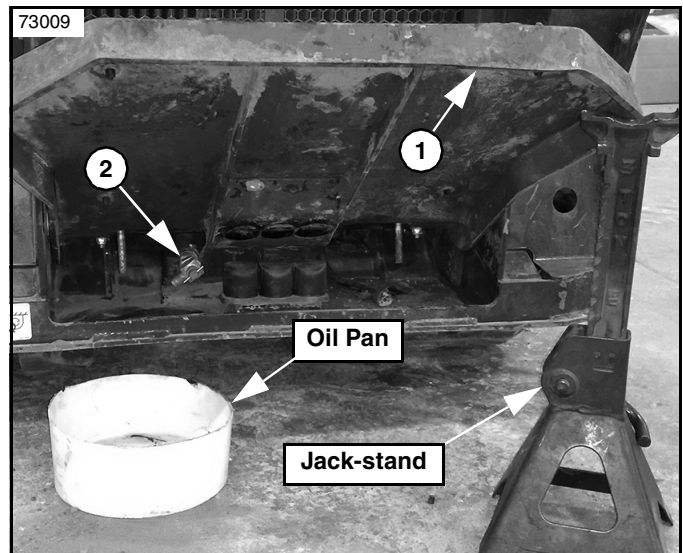

Oil Drain Valve
Figure 5-24

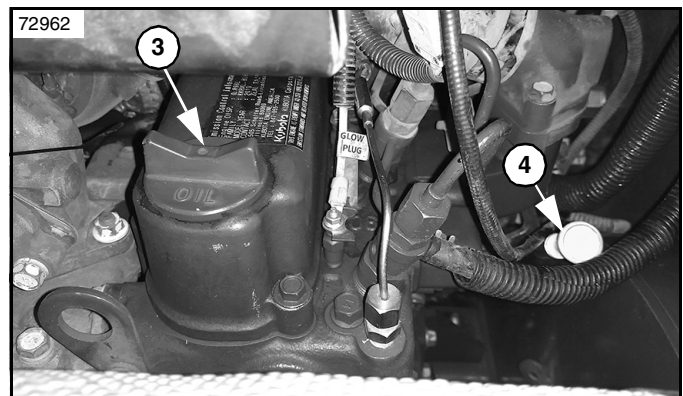

Oil Cap
Figure 5-25

Change the Oil Filter

WARNING

To avoid serious injury or death:

The following procedure should be performed with the machine on a flat, level surface, the loader arms completely lowered and the machine turned off. Use all the appropriate personal protective equipment when performing maintenance.

With the oil drained from the engine, following the “Change the Engine Oil” procedure on page 57, proceed with the following steps to change the oil filter.

Refer to Figure 5-26 & Figure 5-27:

1. Remove oil filter access cover (#1) by removing bolt (#3) with a ratchet and a 9/16” socket. Set cover (#1) off to the side.
2. Attach an oil filter wrench to a 1/2” drive ratchet and extension as shown in Figure 5-27.
3. Remove oil filter (#2) with the oil filter wrench and make sure that its O-ring comes off with it.

IMPORTANT: Failure to remove the old O-ring can result in an improper seal with the new oil filter.

NOTE: With the oil filter removed, it is a good time to check the fan belt tension. See “Check Fan Belt Tension” on page 56.

4. Add a little oil to the O-ring on new oil filter (#4) for lubrication when tightening. See Figure 5-28.
5. Fasten new oil filter (#4) by hand or by using the oil filter wrench.

IMPORTANT: To avoid stripping threads, do not over tighten the oil filter. It is best to hand tighten.

6. Replace oil filter access cover (#1) and tighten bolt (#3) to the correct torque.
7. Proceed with step 6 of the “Change the Engine Oil” procedure on page 57.

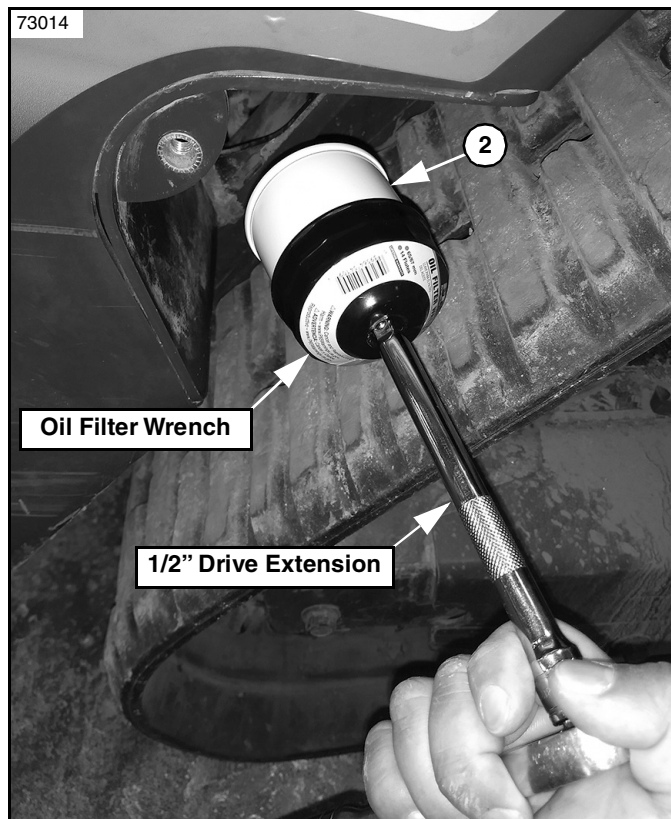

Oil Filter Removal
Figure 5-27

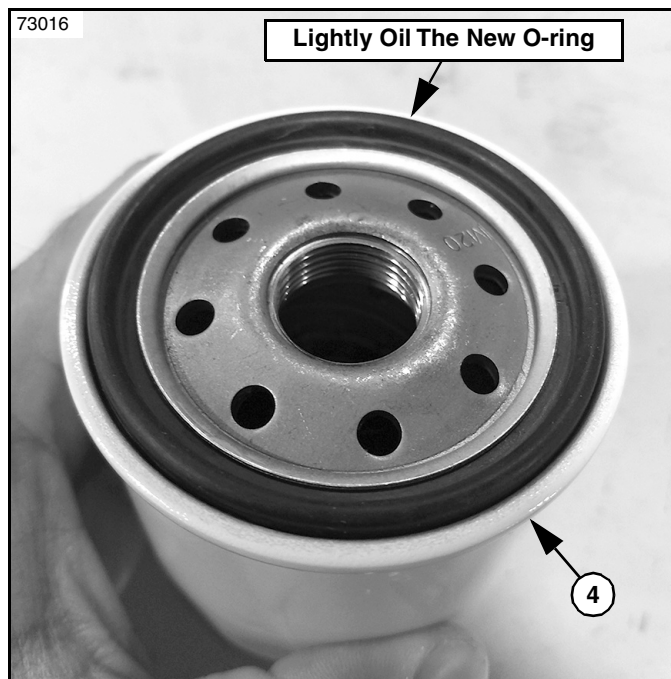

Oil Filter
Figure 5-28

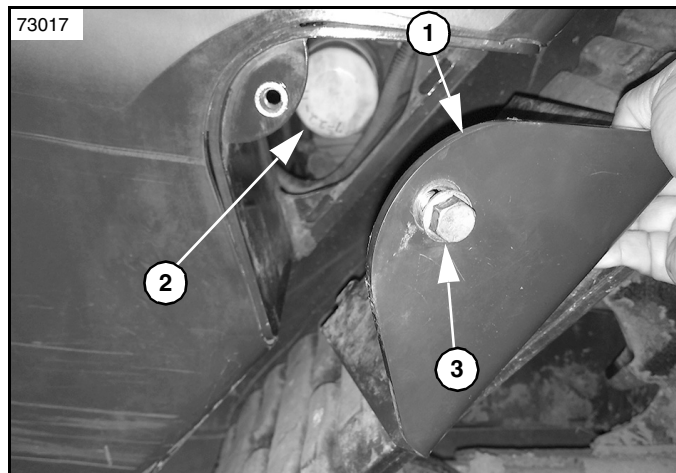

Cover Removal
Figure 5-26

Section 5: Maintenance & Lubrication

Every 200 Hours

For your own safety and to assure the long life of your machine, the following maintenance should be performed every 200 hours.

Fan Belt Adjustment

WARNING

To avoid serious injury or death:

The following procedure should be performed with the machine on a flat, level surface, the loader arms completely lowered and the machine turned off. Use all the appropriate personal protective equipment when performing maintenance.

NOTE: Fan belt tension should be checked and tightened, if needed, when changing the oil filter as it will be easier while the filter access cover is off.

Refer to Figure 5-20:

1. Remove oil filter access cover (#1) by removing bolt (#2) with a ratchet and a 9/16" socket. Set cover (#1) off to the side.

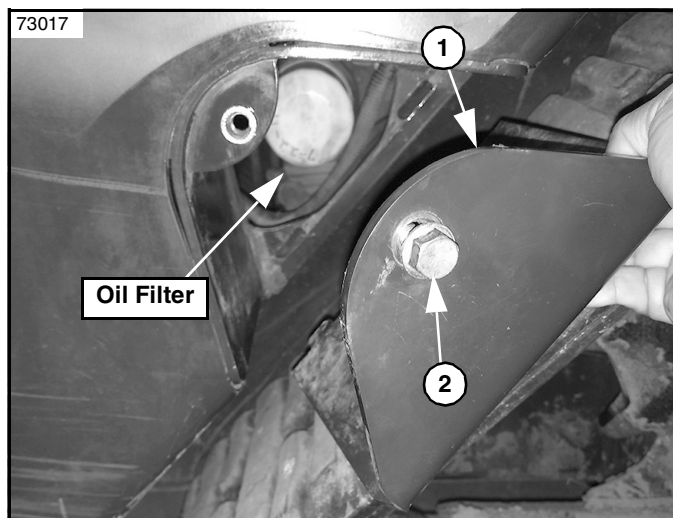

Oil Filter Cover Removal
Figure 5-29

Refer to Figure 5-21:

2. With a tension checker, apply force to the fan belt between the fan drive pulley and the alternator pulley.
3. Measure the deflection.

Refer to Figure 5-22:

4. If the measurement is out of the service specifications, loosen the top alternator mounting bolt (#3) and adjust the fan belt tension.

NOTE:

- Pivoting the alternator closer to engine will loosen the fan belt tension.
- Pivoting the alternator away from the engine will tighten the fan belt tension.

5. Tighten the top alternator mounting bolt (#3) to the alternator after adjusting the fan belt tension.

Service Specification	
Deflection	7.0 to 9.0 mm
	0.28 to 0.35 in. (Under load of 98 N-m or 22 lbf)

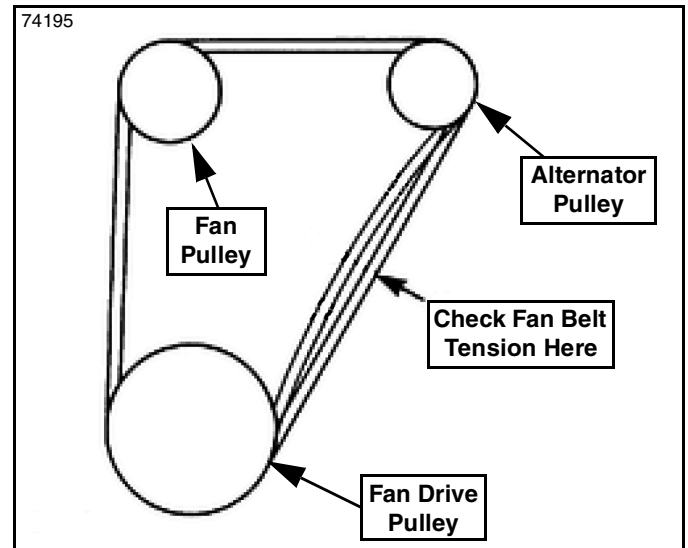

Fan Belt & Pulleys
Figure 5-30

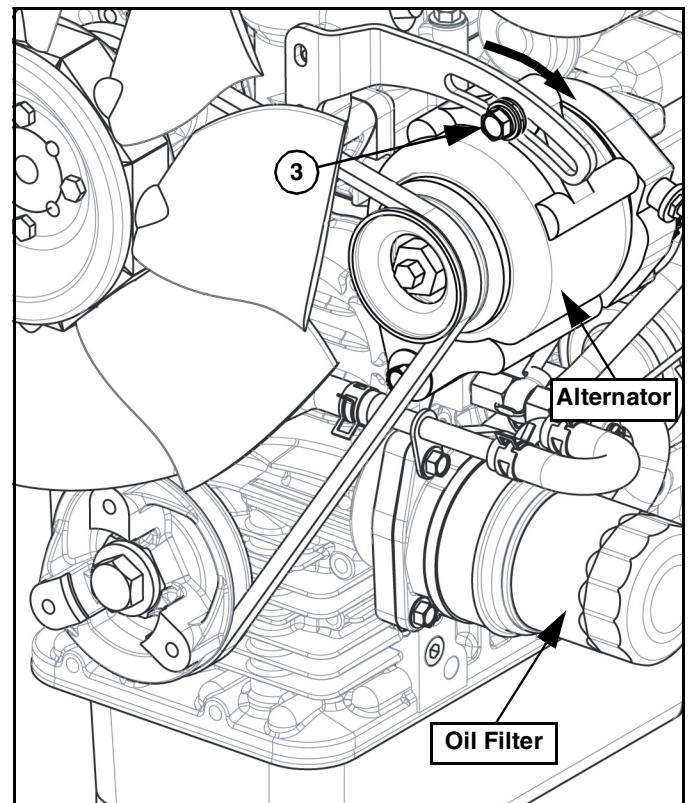

Fan Belt Tensioning
Figure 5-31

Every 250 Hours

For your own safety and to assure the long life of your machine, the following maintenance should be performed every 250 hours.

Change Air Cleaner Element

WARNING

To avoid serious injury or death:

The following procedure should be performed with the machine on a flat, level surface, the loader arms completely lowered and the machine turned off. Use all the appropriate personal protective equipment when performing maintenance.

IMPORTANT: If the machine is used in dusty conditions for several hours, Changing the air cleaner element should be done more frequently.

Refer to Figure 5-32 & Figure 5-33:

1. Open the machine's hood. See "Opening & Closing the Hood" on page 48.
2. Release latches (A & B) on air cleaner cover (#1).
3. Remove the air cleaner cover (#1).
4. Remove outer element filter (#3).
5. Clean the inside of air cleaner cover (#1) with compressed air.
6. Clean the inside of air cleaner body (#5) with a damp paper towel or rag.

IMPORTANT: Do not clean the inside of the air cleaner body with compressed air.

IMPORTANT: If the inner element filter does not need cleaned or replaced, do not remove it.

7. Check inner element filter (#4). If it needs cleaned or replaced, gently pull it out of air cleaner body (#5). If inner element filter (#4) only needs cleaned, blow compressed air through it from the inside of the filter as shown in Figure 5-34.

IMPORTANT: If the inner element needs cleaned, this indicates that the outer element has failed and needs replaced.

8. Re-install or replace inner element filter (#4) in air cleaner body (#5).

IMPORTANT: Make sure that the open end of the inner element filter is inserted into the back of the air cleaner. If the inner element filter is installed backwards, it will cause poor performance and engine damage.

9. Replace outer element filter (#3) in air cleaner body (#5).

10. Fasten the air cleaner cover (#1) to air cleaner body (#5) with evacuator valve (#2) pointing down as shown in Figure 5-32.

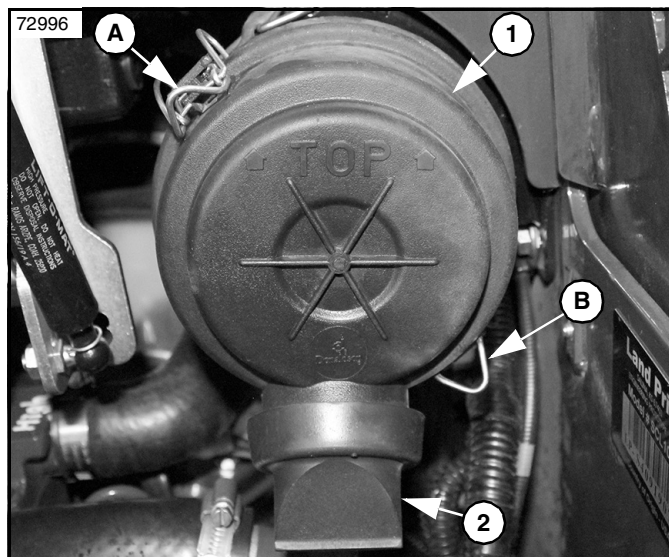

Cover Removal
Figure 5-32

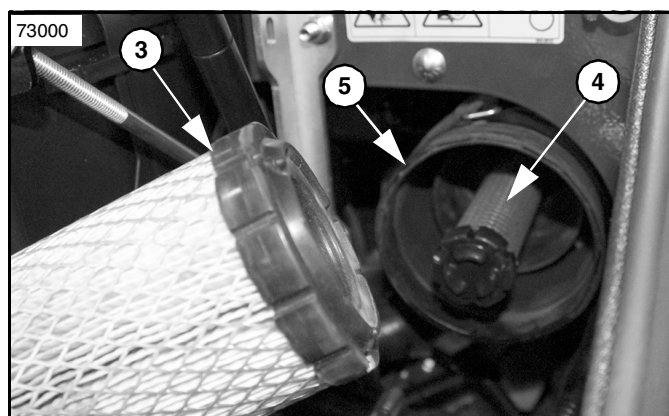

Filter Elements
Figure 5-33

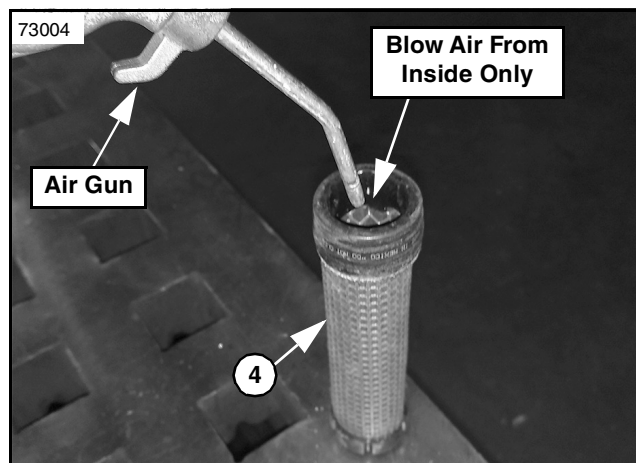

Inner Element Filter Cleaning
Figure 5-34

Change the Fuel Filter

! WARNING

To avoid serious injury or death:

The following procedure should be performed with the machine on a flat, level surface, the loader arms completely lowered and the machine turned off. Use all the appropriate personal protective equipment when performing maintenance.

Refer to Figure 5-35 & Figure 5-36:

1. Open the machine's hood. See "Opening & Closing the Hood" on page 48.
2. Remove fuel filter (#1) by hand or with a filter wrench.
3. Fill new fuel filter (#2) with clean fuel and apply some fuel to the gasket for lubrication.
4. Attach new fuel filter (#2) and hand tighten it.
5. Purge the fuel system with the following steps:

Refer to Figure 5-37:

- a. Loosen the fuel bleed screw on the engine with a 10mm wrench or 10mm socket and ratchet wrench.
- b. Flip the power switch to turn on the display. Enter passcode to run the fuel pump for 30 seconds.
- c. When fuel reaches the bleed screw and no bubbles form, tighten the bleed screw. If the fuel pump turns off and fuel has not reached the bleed screw, push the start button, but do not hold to restart the fuel pump.
- d. Start the engine and let it run until it sounds like it is running smoothly.

IMPORTANT: Do not loosen the bleed screw on the water separator as this will introduce air into the fuel lines. This can damage the fuel pump if it is running.

IMPORTANT: Failing to purge the fuel system can leave air in the fuel lines and cause damage to the machine.

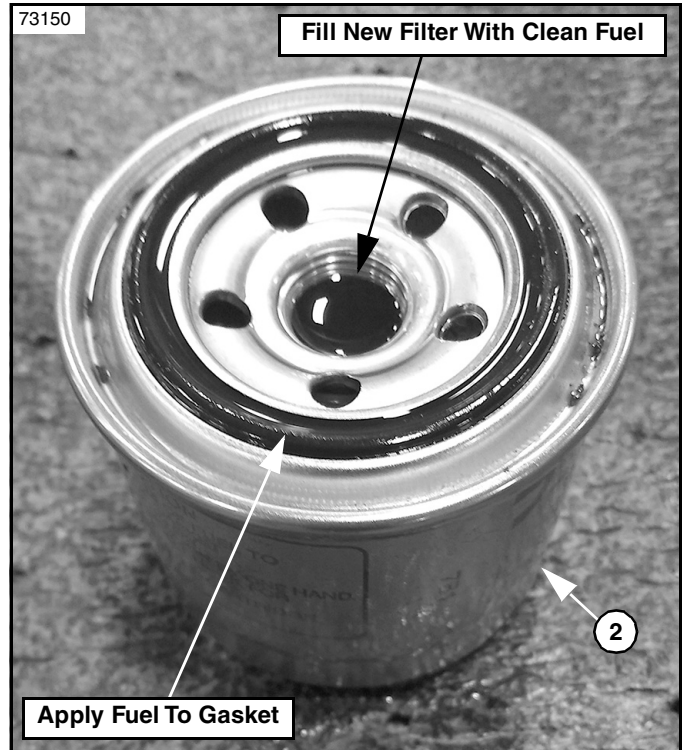

New Fuel Filter Installation
Figure 5-36

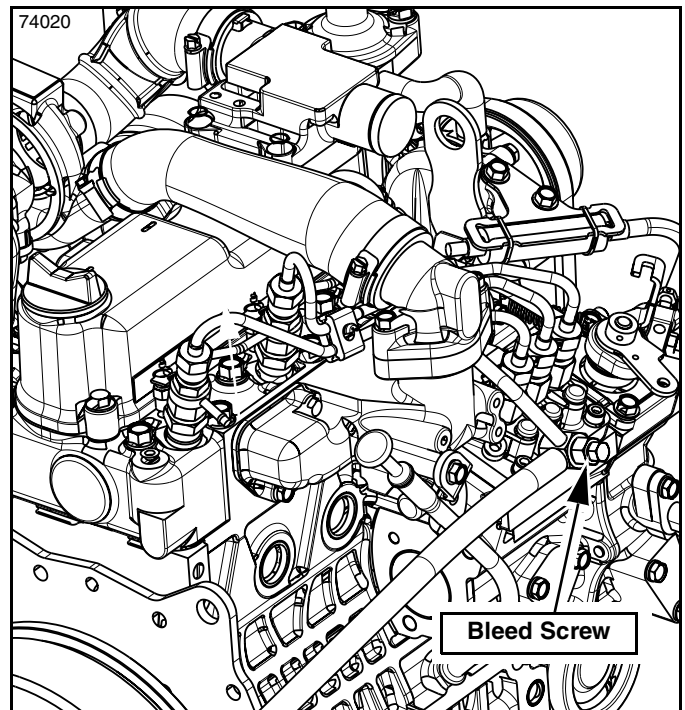

Bleed Screw
Figure 5-37



Fuel Filter Location
Figure 5-35

Change Hydraulic Return Filter

WARNING

To avoid serious injury or death:

The following procedure should be performed with the machine on a flat, level surface, the loader arms completely lowered and the machine turned off. Use all the appropriate personal protective equipment when performing maintenance.

Refer to Figure 5-38 & Figure 5-39:

1. Open the machine's hood. See "Opening & Closing the Hood" on page 48.
2. Remove hydraulic oil filter (#1) by hand or with a filter wrench.
3. Fill new hydraulic oil filter (#2) with clean hydraulic oil and apply some oil to the gasket for lubrication.
4. Attach new hydraulic oil filter (#2) and hand tighten it.
5. Turn machine on and let it idle for a few minutes, then shut the machine back down.

Refer to Figure 5-40:

6. Check oil level sight (#3) to see if enough oil is present. Oil level should be at or near the middle of oil level sight (#3).
7. Add hydraulic oil to hydraulic oil tank (#4) as needed. See "Check Hydraulic Oil Level" on page 52 for further detailed instructions on adding hydraulic oil.

IMPORTANT: Always refill with the correct hydraulic oil. See "Recommended Fluids" on page 69. Using the wrong hydraulic oil can result in damage to the hydraulic system.

IMPORTANT: Wipe away all sand, dirt or dust from the oil port before adding hydraulic oil.

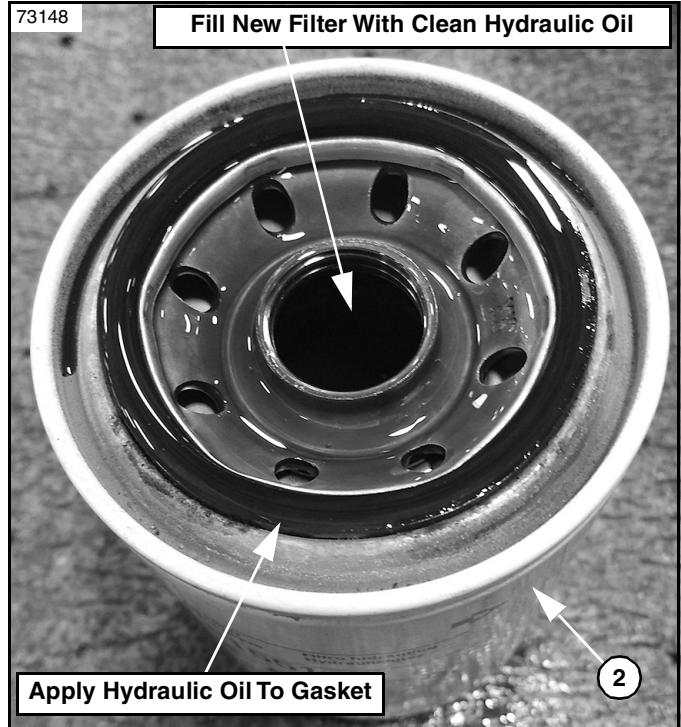

New Hydraulic Oil Filter Installation
Figure 5-39

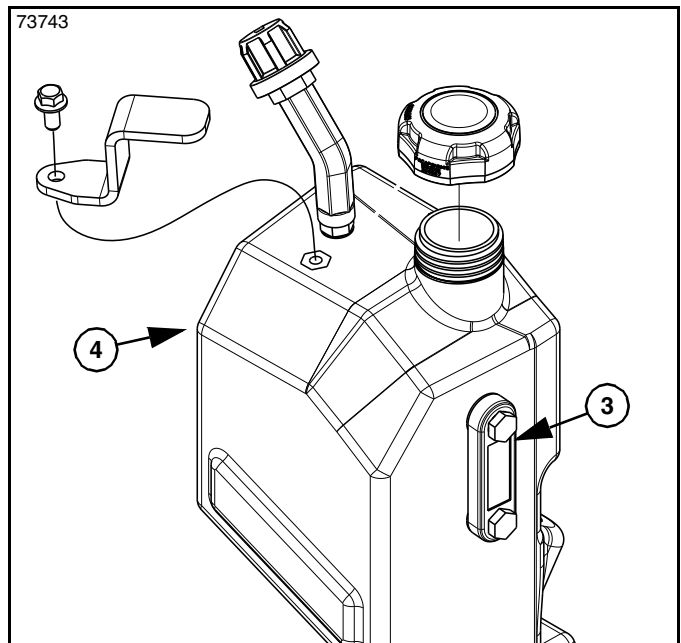

Hydraulic Oil Level Check
Figure 5-40

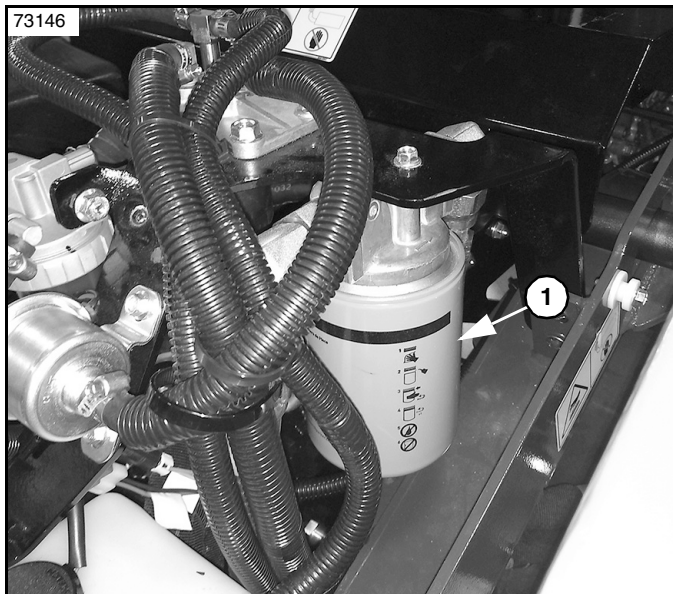

Hydraulic Oil Filter Location
Figure 5-38

Section 5: Maintenance & Lubrication

Every 500 Hours

For your own safety and to assure the long life of your machine, the following maintenance should be performed every 500 hours.

Change the Hydraulic Oil

DANGER

To avoid serious injury or death:

When it is required that the machine be elevated off the ground to perform maintenance, make certain the machine is being hoisted up by a capable hoist and straps. Make sure to use solid, non-concrete blocks or jack stands that are sturdy and are capable of bearing the machine's weight. Make sure the engine is shut off.

Refer to Figure 5-41:

1. Hoist the machine onto solid, non concrete supports.
2. Remove the belly access panel (#1) by removing six 5/16"-18 x 5/8" GR5 flange bolts (#2) with a ratchet and a 1/2" socket.

NOTE: There are 2 belly access panels under the machine. For this procedure, remove the front most access panel.

3. Remove hydraulic oil plug (#3) using a 5/16" allen wrench and drain the oil into a bucket or an oil catch.
4. When all the hydraulic oil has been drained, re-install hydraulic oil plug (#3).
5. Re-attach belly access panel (#1) to the machine's frame with six 5/16"-18 x 5/8" GR5 flange bolts (#2). Tighten to correct torque.

Refer to Figure 5-42:

6. Open the machine's hood. See "Opening & Closing the Hood" on page 48.
7. Remove hydraulic cap lock (#5) by removing 3/8-16 X 3/4 GR5 flanged bolt (#6). Remove dust and dirt from hydraulic oil tank (#4) and hydraulic oil tank cap (#3).
8. Remove hydraulic oil tank cap (#3) and add hydraulic oil up to the middle of oil level sight (#1). It is important for the protection of the hydraulic system to only use the recommended hydraulic oil. See "Recommended Fluids" on page 69.
9. Replace oil tank cap (#3) then replace hydraulic cap lock (#5) with 3/8-16 X 3/4 GR5 flanged bolt (#6).
10. Turn the machine on and allow machine to idle for 1 minute before operating any hydraulics to allow the hydraulic oil to be filtered before reaching any contamination-sensitive areas.
11. Operate the hydraulic controls for five minutes, then shut the machine down again.
12. Check the oil level. Oil level should be at or near the middle of oil sight (#7). Repeat steps 6-10 to add hydraulic oil as needed.
13. Properly dispose of old hydraulic oil.

IMPORTANT: Do not over-fill the hydraulic oil tank over its specified limit. Use only the recommended hydraulic oil. See "Recommended Fluids" on page 69. Using the wrong hydraulic oil can result in damage to the hydraulic system.

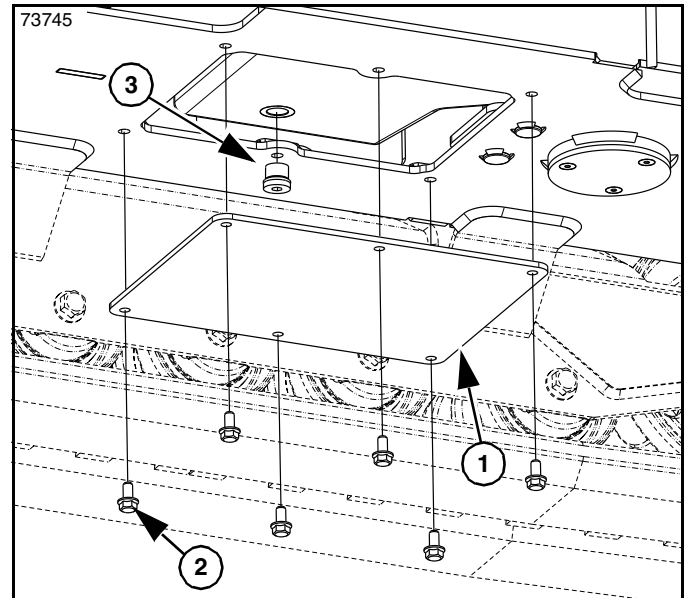

Belly Access Panel & Oil Plug
Figure 5-41

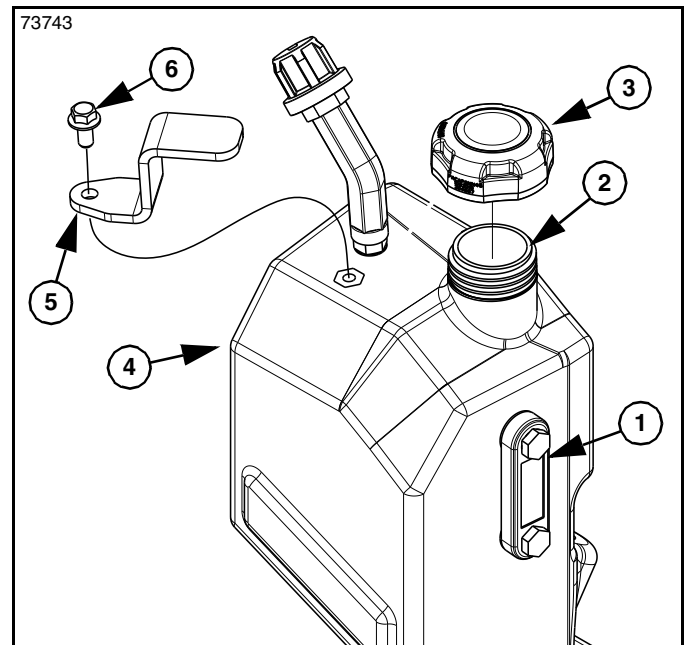

Hydraulic Oil Level Check
Figure 5-42

Every 1 Year

For your own safety and to assure the long life of your machine, the following maintenance should be performed every 1 year.

Hydraulic Tank Breather Change

WARNING

To avoid serious injury or death:

The following procedure should be performed with the machine on a flat, level surface, the loader arms completely lowered and the machine turned off. Use all the appropriate personal protective equipment when performing maintenance.

Refer to Figure 5-43:

1. Open the machine's hood. See "Opening & Closing the Hood" on page 48.
2. Remove tank breather (#1) by hand or by using a 1-1/16" wrench and dispose of it.
3. Properly apply thread seal tape to the threads on new tank breather (#1).
4. Hand tighten tank breather (#1) onto tank breather fitting (#2).

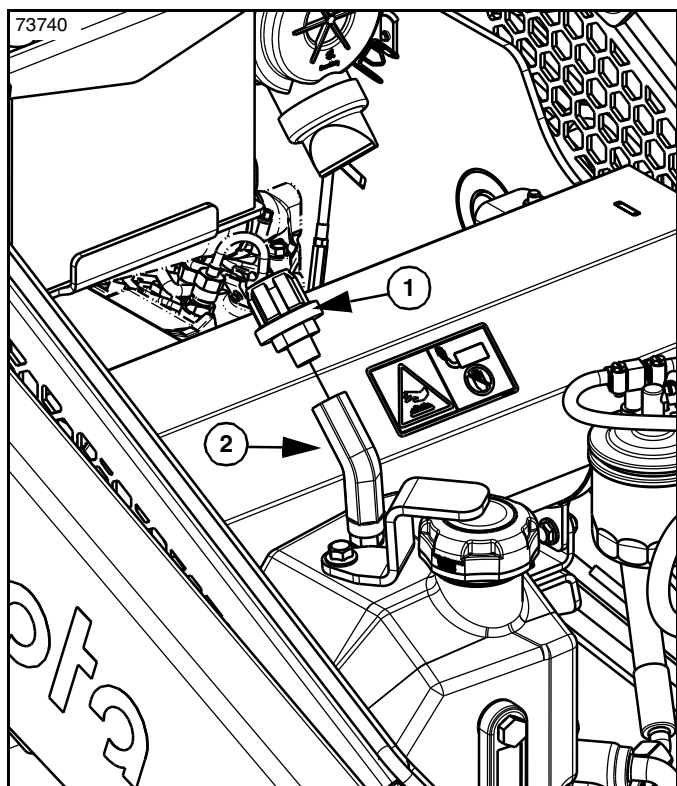

Hydraulic Tank Breather
Figure 5-43

Every 2 Years

For your own safety and to assure the long life of your machine, the following maintenance should be performed every 2 years.

Change the Coolant

WARNING

To avoid serious injury or death:

- The following procedure should be performed with the machine on a flat, level surface, the loader arms completely lowered and the machine turned off. Use all the appropriate personal protective equipment when performing maintenance.
- Allow the radiator to cool down before removing the radiator cap.

Refer to Figure 5-44 & Figure 5-45:

1. Remove lower radiator cover (#1) by removing three 1/4"-20 x 1/2" GR5 flange bolts (#2) with a ratchet wrench and 3/8" socket.
2. Use a 3/8" wrench to remove radiator plug (#3).
3. Drain coolant into a container such as an oil drain pan or a bucket.

NOTE: Have a piece of hose ready to help drain the coolant into a container. See Figure 5-46.

4. Re-attach radiator plug (#3). Use seal tape on the threads and tighten to proper torque.
 5. Re-attach lower radiator cover (#1) with three 1/4"-20 x 1/2" GR5 flange bolts (#2). Tighten to correct torque.
- #### Refer to Figure 5-47 & Figure 5-48:
6. Open the waist cushion. See "Opening & Closing the Waist Cushion" on page 48.
 7. Twist off radiator cap (#4) from radiator (#5).
 8. Open up the control panel. See "Opening & Closing the Control Panel" on page 48.
 9. Pop off recovery tank lid (#6) from recovery tank (#7).
 10. Fill radiator (#5) with coolant then fill recovery tank (#7) to the full mark. Use a clean funnel if needed.

IMPORTANT: Use 50/50 mix coolant only.

11. Twist radiator cap (#4) back on radiator (#5).
12. Pop recovery tank lid (#6) back on to tank (#7).
13. Close the control panel. See "Opening & Closing the Control Panel" on page 48.
14. Turn the machine on and let it run a few minutes at operating temperatures.
15. Check to see if the coolant level is still at the full mark on recovery tank (#7). Add coolant if needed.
16. Close the waist cushion. See "Opening & Closing the Waist Cushion" on page 48.

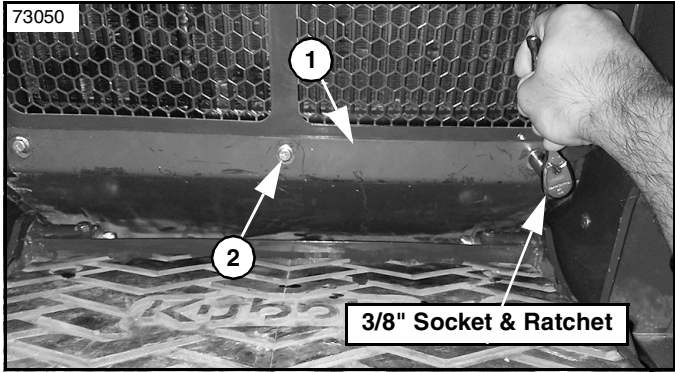

Lower Radiator Cover
Figure 5-44

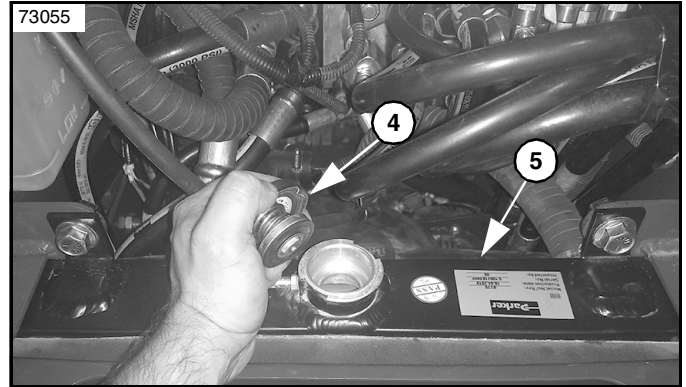

Radiator Cap
Figure 5-47

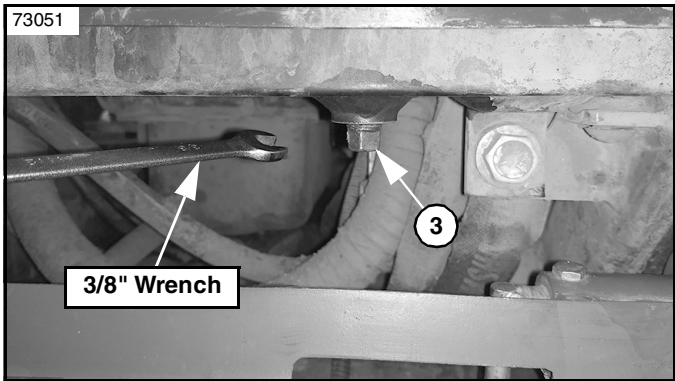

Radiator Plug
Figure 5-45

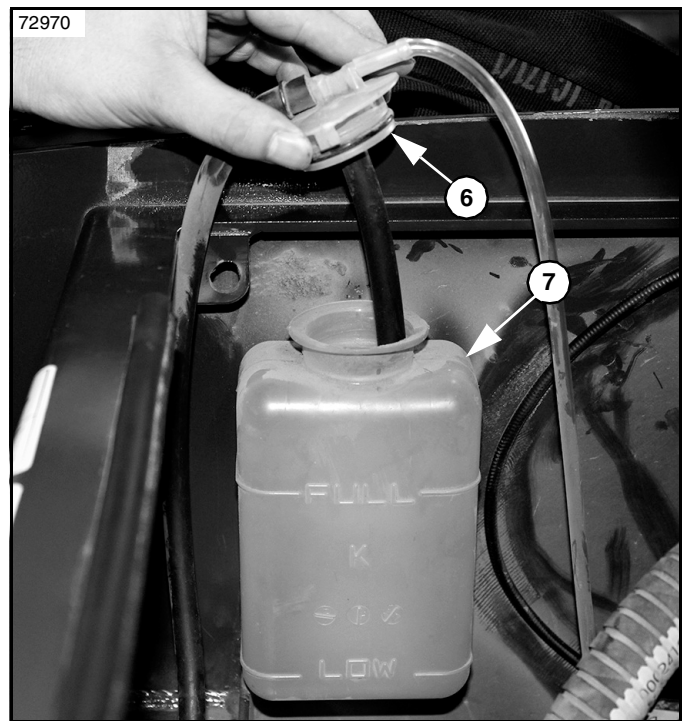

Recovery Tank
Figure 5-48

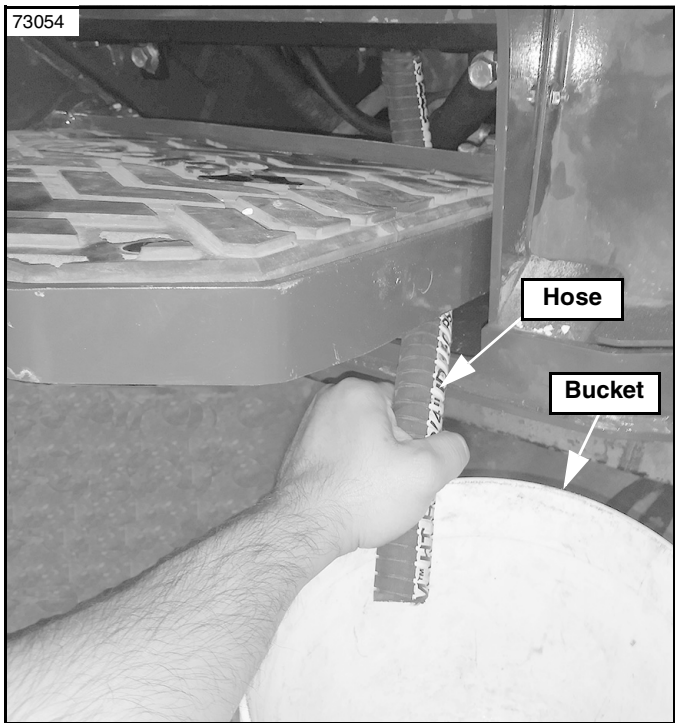

Coolant Draining
Figure 5-46

Long-Term Storage

Clean, inspect, service, and make necessary repairs to the machine when storing it for long periods and when storing it at the end of a working season. This will help ensure that the machine is ready for field use the next time you need it.

WARNING

To avoid serious injury or death:

Do not clean the machine with the engine running as you may accidentally bump the controls.

IMPORTANT: If you wash the machine while the engine is running, water can splash into the air cleaner intake and cause engine damage.

1. Clean the whole machine thoroughly. Remove all built up grease and compacted dirt that may have accumulated on the machine and its moving parts.
2. Inspect the machine for parts that are out of adjustment, loose, damaged or worn.
 - Make required adjustments.
 - Tighten all loose hardware.
 - Replace damaged and worn parts and decals as needed. Contact your Kubota dealer for ordering replacement parts and decals.
3. Repaint parts where paint is worn or scratched to prevent rust. Ask your Kubota dealer for touch-up paint. Paint is available in aerosol can, quarts, and gallon sizes. See chart below.

Touch-Up Paint	
Part No.	Part Description
821-070C	Gloss black enamel spray can
821-070CTU	Gloss black enamel bottle with brush
821-070CQT	Gloss black enamel quart
821-070CGL	Gloss black enamel gallon
821-085C	Gloss gray enamel spray can
821-085CTU	Gloss gray enamel bottle with brush
821-085CGL	Gloss gray enamel gallon
821-066C	Gloss orange enamel spray can
821-066CTU	Gloss orange enamel bottle with brush
821-066CQT	Gloss orange enamel quart
821-066CGL	Gloss orange enamel gallon

4. Replace all damaged or missing decals.
5. Perform an oil change on the machine. See **“Change the Engine Oil”** on page 57.
6. Check the air cleaner element. See **“Check Air Cleaner Element”** on page 54. Change it if necessary.

7. If it is expected that temperatures will fall below freezing, add anti-freeze or drain coolant completely. Refer to **“Change the Coolant”** on page 64 for draining the radiator.
8. Grease and lubricate the machine. See **“Lubrication Points”** on page 70.
9. Heavily grease exposed hydraulic cylinder rods to minimize oxidation.
10. Check track tension and adjust if needed. See **“Check Track Tension”** on page 55.
11. Store the machine on a level surface in a clean, dry place.

IMPORTANT: Storing the machine indoors is ideal as it will reduce maintenance and make for longer life of the machine. If the machine can not be stored indoors, make sure to keep the machine covered with tarps.

12. Remove the battery and store it indoors.

IMPORTANT: When operating the machine after it has been in storage for a long time, wipe off the grease from the hydraulic cylinder rods. Turn on the engine and operate the hydraulics and the drive mechanisms under no load in order to circulate the hydraulic oil.

If the machine is stored for longer than one month, follow these procedures once every month.

Periodic Replacement of Important Parts

To ensure safety in operation, you are strongly requested to inspect and service the machine at regular intervals. For added safety, ask your Kubota dealer to replace the following important component parts.

- Fuel hose
- Hydraulic hose
- Radiator hose

These parts are prone to degradation in material or subject to wear and tear with time. It is difficult to judge how much they have been affected at regular inspection. It is therefore necessary to replace them with new ones, whether wear is visible or not after 2 years or 4000 hours.

If any of the parts listed above are found worn even before the specified use, they must be repaired or replaced with no delay. If any of the hose clamps are found deformed or cracked, the hose clamp must also be replaced.

When replacing the hydraulic hoses, change their O rings and seals with new ones.

At the following periodic inspections, check the fuel hoses and hydraulic hoses.

Fuel & Hydraulic Hose Inspection

Inspection Interval	Check Points
Daily check	Check for leaks at fuel and hydraulic hose connections and points.
Every month	Check for leaks at fuel and hydraulic hose connections and points. Check for damage on the fuel and hydraulic hoses (cracks, chafing).
Every year	Check for leaks at fuel and hydraulic hose connections and points. Check for interference, deformation, degradation, twist and other damage (cracks, chafing) of fuel and hydraulic hoses.

IMPORTANT: To prevent serious damage to the hydraulic system, use only a Kubota genuine hydraulic hose.

For replacement parts, contact your Kubota dealer.

Fluid Capacities

Lubricant/Fuel	Component	Capacity	Remarks
Engine oil	Engine	4QT (3.8L)	
Coolant	Radiator without recovery tank	4.2QT (4.0L)	
	Radiator with recovery tank	5QT (4.7L)	
Hydraulic oil	All hydraulic system	6 gal	
	Hydraulic oil tank	4 gal	
Fuel	Fuel tank	7.75 U.S. gal (29.3 L)	

Recommended Fluids

Lubricant/Fuel	Recommendation			Filled at factory	
	Ambient Temperature conditions	Viscosity	Quality standard	Brand	Type
Engine oil	Above 77 °F (25°C)	SAE 10W-30 SAE 10W-40 SAE 15W-40	API classifications: CF, CF-4,CG-4, CH-4	Rotella	T4 SAE 10W30 API CK-4, CJ-4
	14 to 77°F (-10 to 25°C)	SAE 10W-30 SAE 10W-40 SAE 15W-40			
	Under 14°F (-10°C)	SAE 10W-30 SAE 10W-40			
Grease	-	ISO 200	-	Shell Gadus	S2 V220 00
Hydraulic oil	Kubota Super UDT ²			Kubota	Super UDT2
Coolant	-	-	-	-	Antifreeze 50/50 mix conventional green
Fuel	Above 14°F (-10°C)	-	ASTM D975 No.2-D Alternate: No.2-D S15	-	-
	Under 14°F (-10°C)	-	ASTM D975 No.1-D Alternate: No.1-D S15	-	-

Engine oil and fuel grade

NOTE:

• **Engine oil**

- Oil used in the engine should have an American Petroleum Institute (API) service classification and should be a proper SAE engine oil according to the ambient temperature of the machine's environment.
- Perform the initial engine oil replacement 50 hours after first use of the machine.

• **Grease**





- Perform the initial grease replacement 50 hours after first use of the machine.

• **Fuel**

- A Cetane number of 45 is a minimum standard. A Cetane number of 50 or greater is preferred, especially for temperatures below -20°C (-4°F) or elevations above 1,500 m (5,000 ft).
- Diesel fuels conforming with ASTM D975 is recommended.
- Ultra low sulfur fuel is mandatory, when machine is operated in US EPA regulated areas.
- No. 2-D is a distillate fuel with lower volatility for engines in industrial and heavy mobile service (SAE J313 JUN87).

Lubrication Points

Lubrication Legend

-  Multi-purpose spray lube
-  Multi-purpose grease lube
-  Multi-purpose oil lube
-  **50 Hrs**
Intervals in hours at which lubrication is required

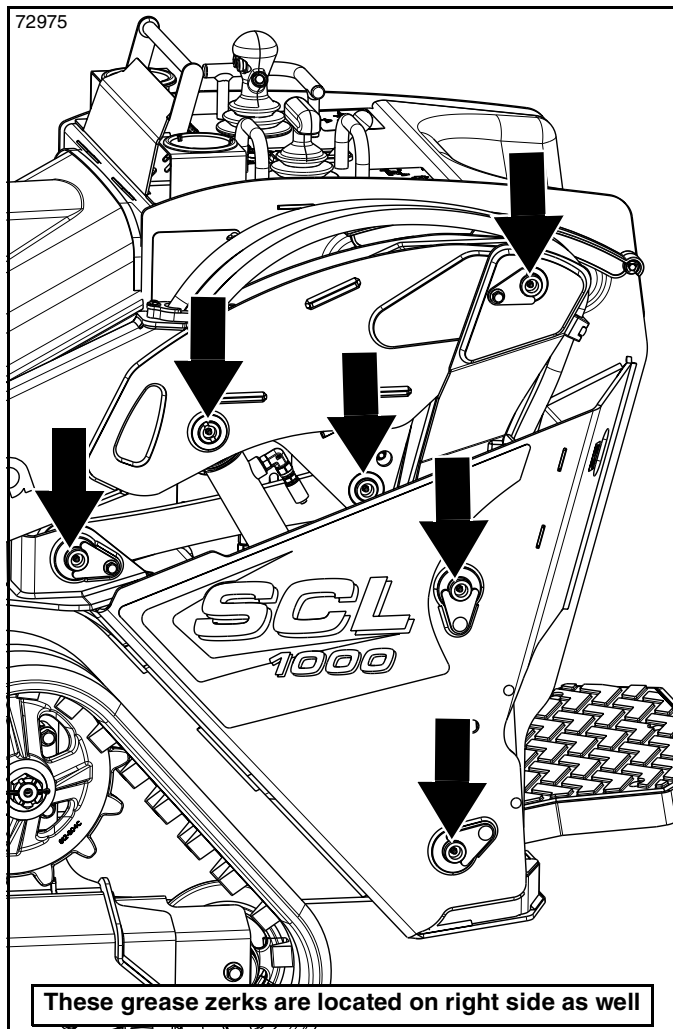



 **10 Hours**

Grease Zerks

12- Zerks (Left and right side of the machine)

Type of Lubrication: Multi-Purpose Grease

Quantity: Add grease until grease begins to emerge.

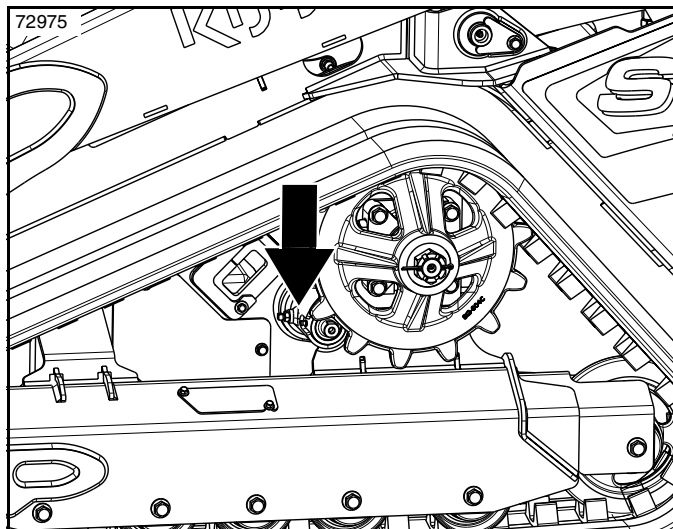



 **10 Hours**

Grease Zerks

1- Zerk

Type of Lubrication: Multi-Purpose Grease

Quantity: Add grease until grease begins to emerge.

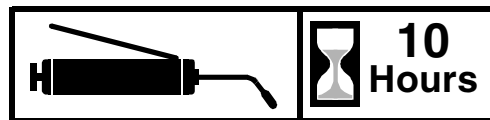
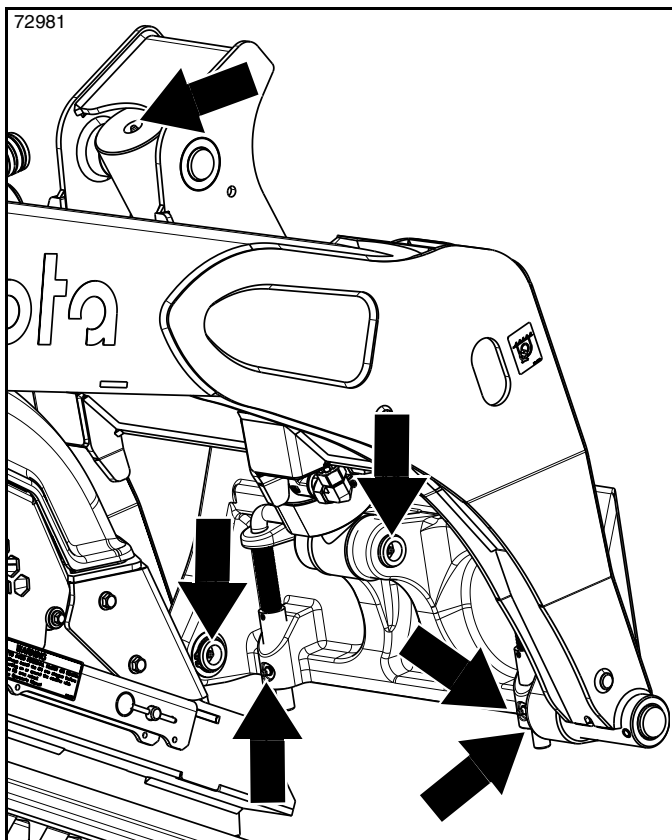

Grease Zerks

6- Zerks

Type of Lubrication: Multi-Purpose Grease

Quantity: Add grease until grease begins to emerge.

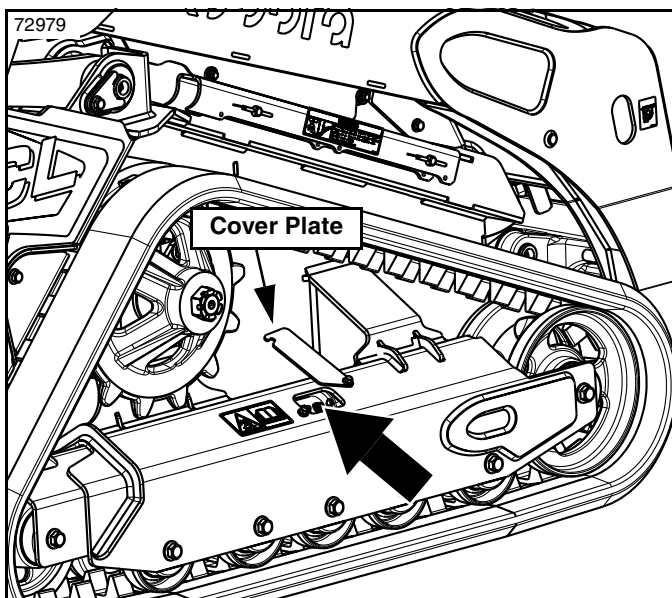

Grease Zerks

2- Zerks (Open cover plate on both sides of machine)

These zerks are for adjusting track tension

Type of Lubrication: Multi-Purpose Grease

Quantity: Add grease until the track is at proper tension.

SCL1000

Specifications & Capacities	
Engine	
Engine Type	Water cooled 4 cycle diesel engine with 3 cylinder, turbo, EPA Tier 4
Model Name	KUBOTA D902-T
Total Displacement	54.8 cu. in. (898 cm ³)
Engine Power - SAE J1995 Gross	24.8 HP (18.5 kW/rpm)
Rated Speed	2800 rpm
Low Idling Speed	1250 rpm
Dimensions	
Overall Length - Transport (w/Std Bucket Parallel to Ground)	107.7" (2.74 m)
Overall Length (w/o Bucket)	84.9" (2.16 m)
Overall Height	55.7" (1.41 m)
Overall Width w/o Std Bucket	35.8" (90.9 cm)
Operating Weight (w/175 lb. Operator)	3,035 lbs (1376 kg)
Rated Operating Capacity (35%)	1000 lbs (460 kg) ROC
Tipping Load	2,857 lbs (1296 kg)
Wheel Base	40.5" (1.03 m)
Hinge Pin Height at Max. Lift	84.7" (2.15 m)
Reach at Max. Lift	22.2" (56.4 cm)
Track Width	9.8" (25.0 cm)
Ground Clearance	7.4" (18.8 cm)
Angle of Departure	25.2°
Performance	
Attachment Mounting System	CII (Common Industry Interface) or 2 Lever Quick-Attach
Travel Speed	4.9 mph (8.2 km/h)
Ground Pressure (with Operator)	4.0 psi (28.0 kPa)
Battery Capacity	12V, RC 80, 540 CCA
Auxiliary Hydraulic Flow	15 gal/min (56.8 L/min)
Auxiliary Hydraulic Pressure	2800 psi (19.3 MPa)
Service & Fill Capacities	
Fuel Tank Capacity	7.75 gal (29.3 L)
Hydraulic Oil Capacity	6 gal (22.7 L)
Engine Oil Capacity	4 QT (3.8 L)
Battery	
Operating Temperature Range	5°F ~ 140°F (-15°C ~ +60°C) (continuous use) -22°F ~ 167°F (-30°C ~ +75°C) (short time use 2 ~ 3hrs)

73068

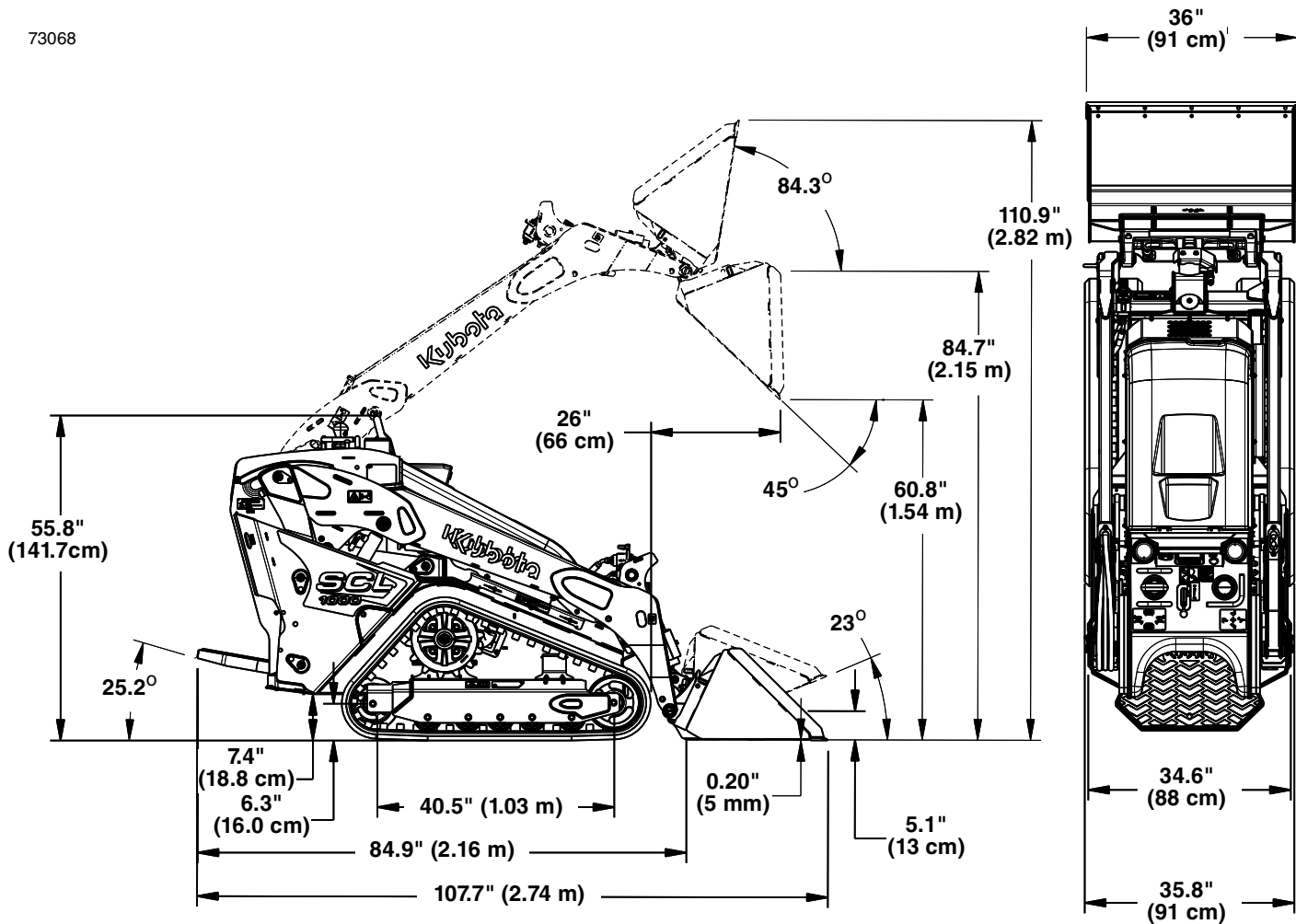

SCL1000

Features	Benefits
Narrow 36" Overall Width	
9.8" wide track standard	The machine's narrow overall width enables it to access areas that a full size machine can not access such as zero clearance yards and inside of commercial buildings. The low impact wide track design (4.0 psi) minimizes damage to lawns and landscaping while maintaining outstanding traction force.
Low 4.0 psi ground pressure	
Outstanding traction force	
Integrated Track Design	
Robust undercarriage welded to main frame	A robust undercarriage and sturdy mainframe make for excellent durability. The welded track frame has an angled top for debris shedding and the dual flange front idler provides better stability and weight distribution. Maintenance time is reduced with permanently sealed and lubricated track rollers. The grease type track tension system makes tensioning the tracks quicker and easier.
Grease track tension design	
Sealed oil bath rollers	
24.8 HP Turbo Charged Engine	
No DPF	The 24.8 HP turbo-charged Kubota engine provides quiet operation, high altitude performance and requires no DPF. The 4.9 mph travel speed is best in class.
High altitude performance	
Quiet operation	
LCD Color Dash Monitoring System	
Keyless start with passcode protection	The machine is equipped with a 4.3" color LCD monitor that provides multiple service indicators and other helpful information pertaining to the machine's health and performance. The monitor also allows for keyless start with passcode protection.
Easy to read consolidated machine monitoring	
Service interval reminders	
Easy to read in sunlight	

Troubleshooting Chart

Problem	Cause	Countermeasure
Engine		
Engine start difficulties	Fuel is too viscous	<ul style="list-style-type: none"> • Check fuel tank & filter. • Remove impurities & water. • If necessary, replace filter.
	Air or water in the fuel system	<ul style="list-style-type: none"> • Remove water from the fuel tank. • Check fuel pipe joint bolts and nuts for looseness. • Purge the fuel system.
	Fuse is blown out	<ul style="list-style-type: none"> • Check the fuse and replace it with a same-capacity one as required.
	Battery dead or almost dead	<ul style="list-style-type: none"> • Recharge or replace battery.
Insufficient engine power	Low fuel level	<ul style="list-style-type: none"> • Check fuel and add if necessary.
	Clogged air cleaner	<ul style="list-style-type: none"> • Clean the air cleaner element.
Engine suddenly stops	Low fuel level	<ul style="list-style-type: none"> • Check fuel and add if necessary. • Purge the fuel system.
Abnormal exhaust smoke color	Poor fuel	<ul style="list-style-type: none"> • Use high quality fuel.
	Too much engine oil	<ul style="list-style-type: none"> • Drain engine oil to specified oil level.
Water temp. in red zone (overheating)	Loose or worn fan belt	<ul style="list-style-type: none"> • Adjust or replace the belt.
	Thermostat defective	<ul style="list-style-type: none"> • Replace the thermostat.
	Coolant level too low	<ul style="list-style-type: none"> • Fill to specified level.
	Radiator grill or fins are clogged	<ul style="list-style-type: none"> • Clean the radiator grill and fins.
	Coolant is contaminated	<ul style="list-style-type: none"> • Replace coolant fluid and add anti-rust.
	Defective radiator cap (evaporation)	<ul style="list-style-type: none"> • Replace the radiator cap.
	Continuous operation under full load	<ul style="list-style-type: none"> • Reduce load.
	Engine oil level too low	<ul style="list-style-type: none"> • Fill to specified level.
Use of poor fuel	<ul style="list-style-type: none"> • Use specified fuel. 	
Hydraulic system		
Low or no power in lift arms, attachment and/or drive unit.	Hydraulic oil level too low	<ul style="list-style-type: none"> • Add oil.
	Hydraulic oil leak in hoses and/or joints	<ul style="list-style-type: none"> • Replace hose or joint. • Tighten connection to correct torque.
	Operator is off of the operator platform	<ul style="list-style-type: none"> • Operate from the operator platform.
Drive system		
Deviation of drive direction	Blocked with debris	<ul style="list-style-type: none"> • Remove debris.
	Track too loose or too tight	<ul style="list-style-type: none"> • Adjust track tension accordingly.

Torque Values Chart for Common Bolt Sizes													
Bolt Size (inches)	Bolt Head Identification						Bolt Size (Metric)	Bolt Head Identification					
	Grade 2		Grade 5		Grade 8			Class 5.8		Class 8.8		Class 10.9	
in-tpi ¹	N · m ²	ft-lb ³	N · m	ft-lb	N · m	ft-lb	mm x pitch ⁴	N · m	ft-lb	N · m	ft-lb	N · m	ft-lb
1/4" - 20	7.4	5.6	11	8	16	12	M 5 X 0.8	4	3	6	5	9	7
1/4" - 28	8.5	6	13	10	18	14	M 6 X 1	7	5	11	8	15	11
5/16" - 18	15	11	24	17	33	25	M 8 X 1.25	17	12	26	19	36	27
5/16" - 24	17	13	26	19	37	27	M 8 X 1	18	13	28	21	39	29
3/8" - 16	27	20	42	31	59	44	M10 X 1.5	33	24	52	39	72	53
3/8" - 24	31	22	47	35	67	49	M10 X 0.75	39	29	61	45	85	62
7/16" - 14	43	32	67	49	95	70	M12 X 1.75	58	42	91	67	125	93
7/16" - 20	49	36	75	55	105	78	M12 X 1.5	60	44	95	70	130	97
1/2" - 13	66	49	105	76	145	105	M12 X 1	90	66	105	77	145	105
1/2" - 20	75	55	115	85	165	120	M14 X 2	92	68	145	105	200	150
9/16" - 12	95	70	150	110	210	155	M14 X 1.5	99	73	155	115	215	160
9/16" - 18	105	79	165	120	235	170	M16 X 2	145	105	225	165	315	230
5/8" - 11	130	97	205	150	285	210	M16 X 1.5	155	115	240	180	335	245
5/8" - 18	150	110	230	170	325	240	M18 X 2.5	195	145	310	230	405	300
3/4" - 10	235	170	360	265	510	375	M18 X 1.5	220	165	350	260	485	355
3/4" - 16	260	190	405	295	570	420	M20 X 2.5	280	205	440	325	610	450
7/8" - 9	225	165	585	430	820	605	M20 X 1.5	310	230	650	480	900	665
7/8" - 14	250	185	640	475	905	670	M24 X 3	480	355	760	560	1050	780
1" - 8	340	250	875	645	1230	910	M24 X 2	525	390	830	610	1150	845
1" - 12	370	275	955	705	1350	995	M30 X 3.5	960	705	1510	1120	2100	1550
1-1/8" - 7	480	355	1080	795	1750	1290	M30 X 2	1060	785	1680	1240	2320	1710
1-1/8" - 12	540	395	1210	890	1960	1440	M36 X 3.5	1730	1270	2650	1950	3660	2700
1-1/4" - 7	680	500	1520	1120	2460	1820	M36 X 2	1880	1380	2960	2190	4100	3220
1-1/4" - 12	750	555	1680	1240	2730	2010	¹ in-tpi = nominal thread diameter in inches-threads per inch ² N · m = newton-meters ³ ft-lb= foot pounds ⁴ mm x pitch = nominal thread diameter in millimeters x thread pitch						
1-3/8" - 6	890	655	1990	1470	3230	2380							
1-3/8" - 12	1010	745	2270	1670	3680	2710							
1-1/2" - 6	1180	870	2640	1950	4290	3160							
1-1/2" - 12	1330	980	2970	2190	4820	3560							

Torque tolerance + 0%, -15% of torquing values. Unless otherwise specified use torque values listed above.

All locknuts or lubricated fasteners: Use 75% of torque value. (i.e. 1/2"-13 GR5 = 76 ft-lb; 75% of 76 or .75 x 76 = 57 ft-lb)

Legal Disclaimer

Kubota Corporation notes that specifications and technical information are subject to change without notice and Kubota does not represent or warrant that the information in this publication is completely accurate or current; however, Kubota used reasonable efforts to set forth and include accurate and up to date information in this publication. Kubota disclaims all representations and warranties, whether express or implied, including, but not limited to, warranties of merchantability and fitness for a particular purpose and Kubota shall not be liable for any damages, whether compensatory, direct, indirect, incidental, special, or consequential, arising out of or in connection with the use of this publication, or in the information therein.

The Product(s) described in this Publication are designed and manufactured only for the country in which they are initially wholesaled by Kubota. Kubota does not provide parts, warranty or service for any Product which is re-sold or retailed in any country other than the country for which the Product(s) were designed or manufactured.



KUBOTA TRACTOR CORPORATION

1000 Kubota Drive, Grapevine, TX 76051
Telephone: (817) 756-1171

Western Division: 1175 S. Guild Ave., Lodi, CA 95240
Telephone: (209) 334-9910

Midwest Division: 31700 W. 207th ST., Edgerton, KS 66021
Telephone: (913) 215-5915

Central Division: 14855 FAA Blvd., Fort Worth, TX 76155
Telephone: (817) 571-0900

Northern Division: 6300 at One Kubota Way, Groveport, OH 43125
Telephone: (614) 835-1100

Southeast Division: 1025 Northbrook Parkway, Suwanee, GA 30024
Telephone: (770) 995-8855

English (U.S.A)

Code No. 725-137MK
