



**KUBOTA TRACTOR CORPORATION**  
1000 Kubota Drive, Grapevine, TX 76051 | [www.kubotausa.com](http://www.kubotausa.com)

**KUBOTA CANADA LTD.**  
1155 Kubota Drive, Pickering, Ontario L1X 0H4 | 905.294.7477 | [www.kubota.ca](http://www.kubota.ca)



© 2021 Kubota Corporation | Part #: M8-21-EN

**For Earth, For Life**  
**Kubota**

**M8**

**BUILT RIGHT. BUILT READY.**





ALWAYS READY FOR  
**BUSINESS**

---

**ENTER THE NEW  
KUBOTA M8 SERIES:  
YOUR TOUGH 200-HORSEPOWER  
YEAR-ROUND WORKHORSE.**

Our business is always open for business. That's why you need a tractor built ready to get the job done right day after day. Enter the NEW Kubota M8 Series: your tough 200-horsepower year-round workhorse. It's engineered to give you adaptability, performance, and comfort to get jobs done— season after season, year after year.

The Kubota M8 Series leads the way forward with innovative features and is designed to deliver superb flexibility to tackle any challenge.





---

## POWER THROUGH YOUR TASKS

The challenges of today could be different tomorrow. It only makes sense to have a tractor that can adapt to your toughest tasks.

The M8 Series is a 200-horsepower workhorse engineered to power through a wide range of jobs. From cutting, tedding, raking and baling hay to material handling, tillage, planting and more— this durable tractor is built right, built ready for business all year round.





YOUR OFFICE WITH A **VIEW**

---

## SEE IT ALL

Enjoy panoramic 360° views along with a high-visibility roof panel from its robust 4-post cabin. To help with visibility no matter the conditions, front and rear wipers, window defoggers, and rear window defrost are all standard equipment—with optional heated and power-adjustable mirrors. For optimal visibility and operator comfort, the M8 Series is equipped with a standard sun visor and an optional rear visor is available.

---

## CONVENIENT MULTIFUNCTIONAL CONTROL

Take full command of the M8 Series with the intuitive multi-function lever and other controls conveniently mounted on the right-hand armrest.

---

## EZ COMMAND CENTRE

The M8 Series' major functions are logically laid out on a spacious console, all the while keeping every button, switch, and lever within easy reach. Your right hand stays on the multi-function lever, while your left hand is free for steering.





---

## A CABIN WORTHY OF THE LARGEST KUBOTA TRACTOR.

Wide steps and a generous cab entrance welcome you into the M8 Series' spacious interior. With an impressive 148 cubic feet of cabin space, every inch of the M8 Series is crafted to deliver an optimal operational experience.

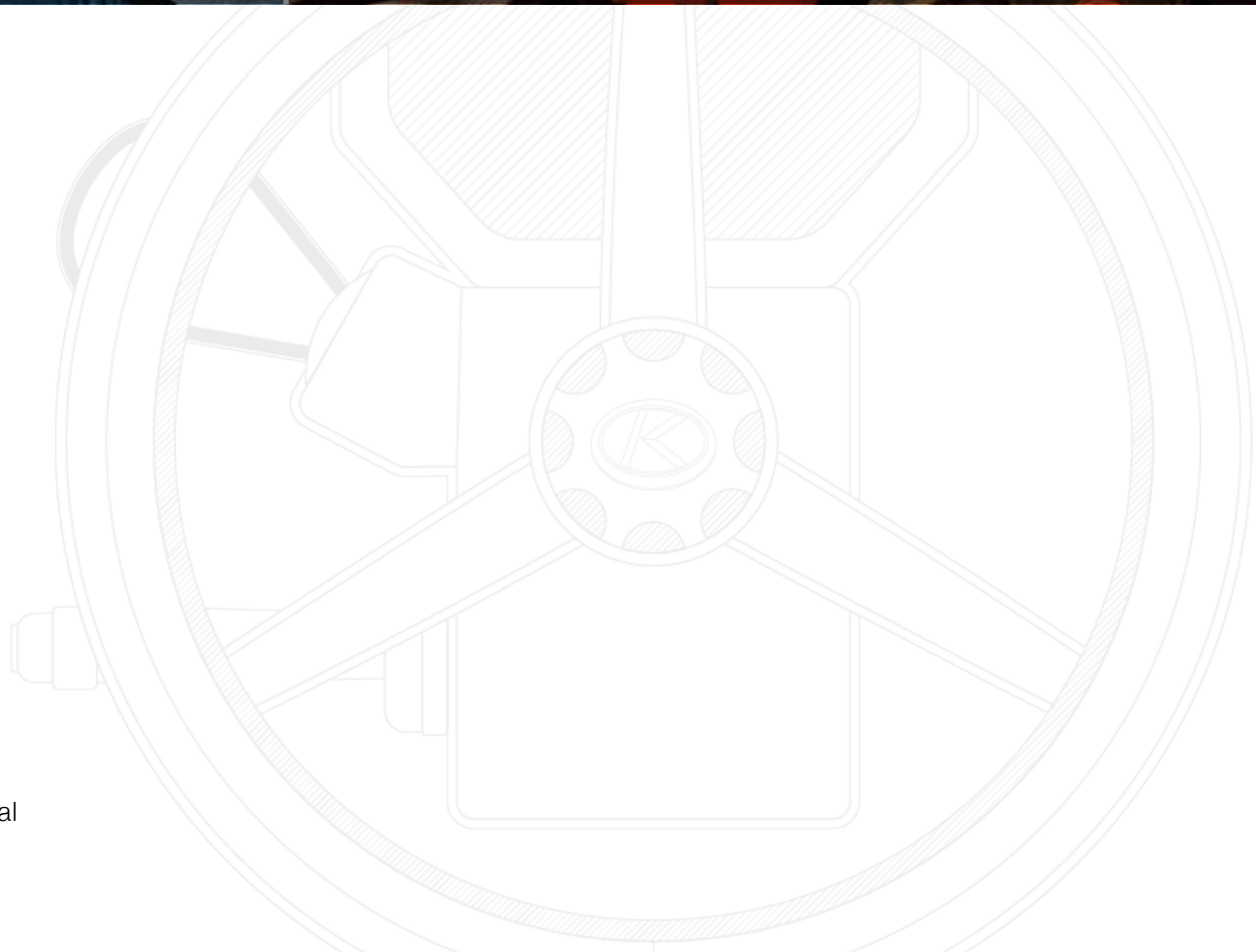

---

### ALL-AROUND ACCESSIBILITY

Enjoy entertainment options, along with easily accessible A/C, radio & light controls. There's even a power-ready USB port, with multiple 12V power outlets available for an extra monitor or other devices and an optional 110V socket.

---

### PLUG THE POWER

The highly requested 12-volt power station is here—and it comes standard in every M8 Series tractor. Now you can charge devices or plugin a laptop at your convenience. For easy access, the plug is strategically placed on the rear left post of the cab.

---

### ALL-WEATHER CLIMATE CONTROL

Keep the cabin comfortable with a manual climate control system or choose to upgrade to the Automatic Temperature Control System.

---

### BEST SEATS IN THE OFFICE

Experience plush seating with standard air suspension for a smooth ride. Upgrade to semi-active suspension, or to the robust package with leather covers, semi-active suspension plus heating/cooling. Enjoy a storage compartment, cup holders, and a cubby to stow away a cellphone within reach of the operator's seat. Additionally, there is a foldable instructor seat that can double as an added workstation.





# POWER MEETS EFFICIENCY

---

## POWER MADE FOR HIGH PERFORMANCE

The M8 series is paired with the formidable and efficient Cummins B6.7 Performance Series engine, one of the most dependable in the market. Available in 180 horsepower\* and 200 horsepower\* models, the B6.7 features an EGR-free design that enables greater fuel efficiency and lower emissions.

This six-cylinder, 6.7L workhorse enhances your productivity using proven single Holset VGT™ variable-geometry turbocharger technology. Overall, this achieves exceptional power density and responsiveness with fuel-efficient performance while delivering outstanding reliability and durability.

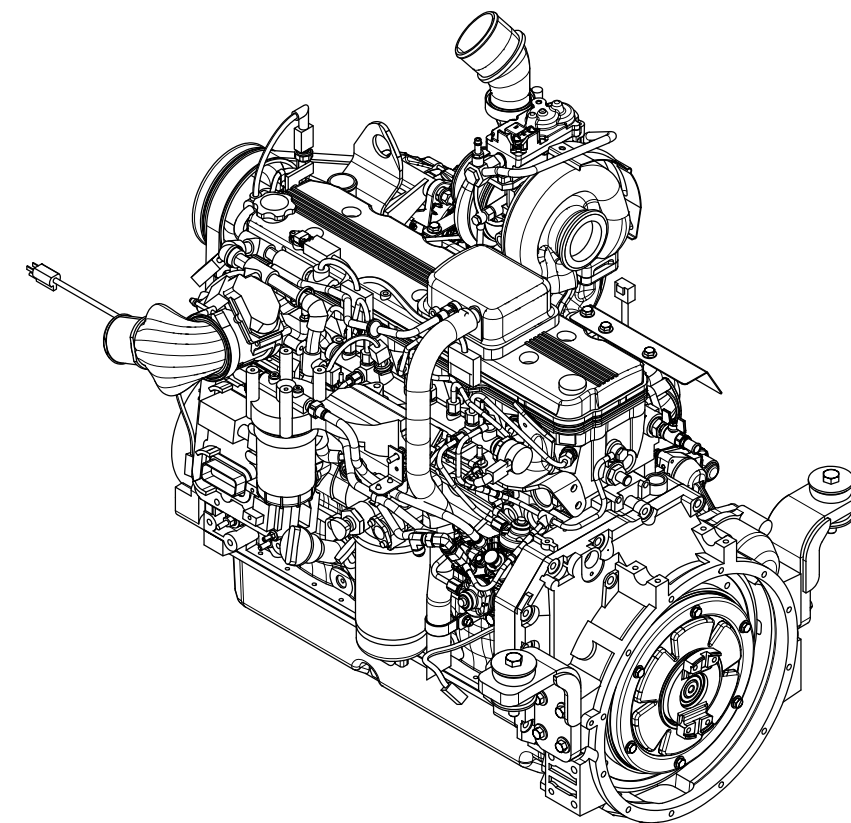

---

## CUMMINS B6.7 TIER 4 FINAL / STAGE V ENGINE

The integrated Single Module™ after treatment system combines the Diesel Oxidation Catalyst (DOC), Diesel Particulate Filter (DPF) and Selective Catalyst Reduction (SCR) in one unit provides clean emissions to meet EPA Tier 4 Final / Stage V standards and deliver great efficiency.

\*Factory estimated rating.

---

**AMPED FOR POWER.  
MAXED FOR EFFICIENCY.**



# UTILITY



## TRANSMISSIONS BUILT FOR A MULTITUDE OF WORK

Power needs the proper transmission to maximize its full potential. The Kubota M8 Series features a fully electronic controlled Semi-Powershift transmission system or the optional KVT transmission. This means the Kubota M8 Series can effectively work at the speed you need.

### SEMI-POWERSHIFT

Quickly reach the right speed for the job thanks to the speed matching feature. The fully electronic controlled Semi-Powershift transmission comes with 30 forward and 15 reverse gears with speeds up to 40 km/h. There are 6 powershift gears per range, with two gear overlaps, reducing the need to make range changes in working conditions. Upgrade to increase travel speed to 50 km/h with a suspended front axle.

### KUBOTA VARIABLE TRANSMISSION (KVT)

Take advantage of a transmission system that provides infinite forward and reverse speeds. Programmed for seamless speed setting to perfectly match the ideal working range for the job.

### ALL PURPOSE 4-SPEED PTO

Select 1 of 4 PTO speeds using the ECO/Standard mode lever and 540/1000 lever that are strategically positioned on the right rear section of the cabin for convenience. Utilizing economy mode will allow the PTO to operate at the required RPM with the tractor set at a lower engine RPM. This improves fuel economy while reducing noise and vibration. Customize PTO modulation to match the load on your implement. Faster modulation for lighter rotational loads or slower modulation for smoother PTO engagement on heavier loads.

### SHUTTLE SHIFT

Enjoy smooth engagement when you change directions when moving forward or in reverse. The M8 comes standard with both a left-hand lever and right-hand multi-function handle control, for more shuttling flexibility.

### RESPONSIVE POWER DELIVERY

The New M8 is tuned with Responsive Power Delivery technology, capable of efficiently giving you the power you need, when you need it. It provides an additional boost of up to 25 horsepower for all-around performance improvements for more applications and jobs — loader work in the yard, pulling loads on the road, and working in the field. Also, this feature independently activates, regardless of whether the PTO is engaged or disengaged.





## OPERATE WITH PRECISION AND CONFIDENCE.

Kubota engineers all our tractors to be easy and simple to use. The M8 Series' intuitive controls and convenient features are designed to streamline and enhance operations. Built with the understanding that your tractor is your office—it must be as comfortable as it is efficient in every way possible.

Likewise, the M8 Series' command centre is crafted with the operator in mind: from a user-friendly interface design and ergonomically arranged controls to a configuration that minimizes hand and foot movement for efficient control of the tractor. The result is an operator experience that delivers confident workability.

### PRECISION FARMING

The M8 is compatible with all industry-leading precision farming solutions. Whether engaging auto steering\* to simplify your tasks on the go or utilizing your prescription mapping to maximize your yields.

\*Third Party Auto Steer Functionality

### K-MONITOR

Easily view the M8 Series' functions through the standard 7" K-Monitor or optional 12" K-Monitor Pro LCD touch screen display. It's simple to use and gives you access to a host of features that help you get the job done. It includes: Tractor Systems Control, ISOBUS compatible implement control, with connectivity for cameras to the monitor.

### ISOBUS STANDARD

The M8 Series is ISOBUS compatible. Simply attach the implement harness to the ISOBUS connector and information will be displayed on the K-Monitor for adjustment and control.

### KUBOTA HEADLAND CONTROL

A smarter way to take control. The Kubota Headland Control allows the creation of customizable programs for fully automated operations of the tractor and ISOBUS compatible implements. The Headland Control System frees the operator to concentrate on maneuvering the tractor, and helps to ensure more efficient turns.





## HYDRAULICS

Built for the tasks of today and tomorrow, the M8 Series is highly customizable to your requirements. Combining precision and speed, the M8 comes with reliable hydraulics and a 3-point hitch that offers maximum flexibility and strength. The M8 Series' hydraulic system delivers superior multitasking and efficiency. Its 3-point hitch can lift mounted equipment easily as well as handle a wide range of implements.

## PRECISION

### FRONT 3-POINT HITCH & PTO OPTION

Experience the flexibility to use a wide range of attachments with the optional Category III 3-point front hitch and front PTO. The operations are made easy with controls located on the armrest.

### REAR 3-POINT HITCH

Engineered to provide easy hook up with cab controls easily accessed from the M8's armrest controls. Take advantage of the standard lift capacity of 5080 kg (11200 lbs.) or upgrade to 6170 kg (13600 lbs.).

### CLOSED CENTRE LOAD SENSING

Enjoy smarter, more efficient control of your hydraulic power to get the job done.

Standard Implement Pump Flow 31.7 gpm (120 l/min)

Optional Implement Pump Flow 42.2 gpm (160 l/min)

3 Valves (Optional 5 Valves)

### LOWER LINKS BALL STANDARD WITH HOOKS OPTION

Comes with reliable standard links or spring for the hook option.

### POWER BEYOND SYSTEM

When applications require high flow with an implement that controls its own hydraulic functions, the M8 has an available Power Beyond System to fill those needs.

1/2" Power Beyond Supply Coupler

3/4" Low Pressure Return Kit Case Drain

3/8" Flat Face Case Drain

3/8" Load Sensing Coupler

### STANDARD LINKS (FLEX ENDS) WITH SWAY BLOCK

### HOOK ENDS LINKS WITH STABILIZER

### CATEGORY III/IIIN

Compatible with Category III and Category IIIN attachments and implements.

### HYDRAULIC TRAILER BRAKES

The M8 offers optional hydraulic trailer brakes to help with implement braking control.





# LOADER

To improve ease and efficiency in a big way, Kubota integrates innovative loader functions into the M8 Series. This includes a mechanical self-leveling system, loader suspension, and impressive lifting capacity throughout the full range of lift height. Plus, these functions are easily executed via the tractor’s excellent visibility and intuitive armrest controls— further enabling smooth, quick, and convenient operations for any job. Best of all, the M8 Series’ boasts a maximum lift height and reach of 4600 mm (181.2”).

### LOADER JOYSTICK

Simplify front loader operations with the easily accessible Kubota engineered control joystick.

### KUBOTA SHOCKLESS RIDE (KSR)

A smooth ride helps minimize fatigue. With the standard KSR, jobs that require lifting and dumping of heavy loads are a lot easier on the operator.

### LIVE 3RD FUNCTION STANDARD WITH OPTIONAL 4TH FUNCTION

Conveniently located on the joystick grip, this function lets you work with a grapple bucket and other hydraulically controlled attachments with ease. Upgrade to add a 4th function for more flexibility.

### MECHANICAL SELF LEVELING

The mechanical self-leveling system easily keeps your attachment level when raising or lowering the boom.

### SINGLE COUPLER LEVEL HYDRAULIC VALVES

Quickly and simultaneously attach or detach all four hoses, with the standard quick-attach system. Ideal for fast, mess-free removal and installation of the loader.

### OPTIONAL HYDRAULIC IMPLEMENT LOCK

Equipped to easily attach and detach attachments such as buckets, bale spears and forks from the operator’s seat.

## TREMENDOUS PERFORMANCE FRONT AND CENTRE

<b>MODEL</b>	M77		
<b>Leveling System</b>	Mechanical self-leveling (MSL)		
<b>Control Type</b>	Electrical joystick		
<b>Standard Equipment</b>	Third function valve, Hydraulic valve quick couplers, Accumulator (KSR: Kubota Shockless Ride)		
<b>Max Lift Height</b>	To Pivot Pin	in. (mm)	181.2 (4600)
	Under Level Bucket	in. (mm)	169.4 (4300)
<b>Clearance with Bucket Dumped</b>	<b>in. (mm)</b>	143.1 (3630)	
<b>Max. Dump Angle</b>	54°		
<b>Bucket Roll-Back Angle</b>	49°		
<b>Lift Capacity*</b>	(Pivot Pin, Max. Height)	lbs. (kg)	5200 (2360)
	(800mm Forward, Max. Height)	lbs. (kg)	5490 (2490)
	(Pivot Pin, Ground Level)	lbs. (kg)	6940 (3150)
	(800mm Forward, Ground Level)	lbs. (kg)	6590 (2990)
<b>Breakforce Force</b>	(800mm Forward, Ground Level)	lbs. (kg)	10140 (4600)

\*Loader lift capacity is limited by GVW and proper ballasting.





WE'RE ON YOUR  
**TEAM**

---

## A PROUD TRADITION OF EXEMPLARY SERVICE.

Kubota is in the business of keeping you in business all year round. And with decades of experience serving North America—we know what it takes to get tough jobs done.

Need to replace a part? We can get it to you thanks to our network of distribution centres. Plus, our highly trained staff and network of independent dealerships have the resources available to keep your M8 operating at peak condition.

We've established this proud tradition of service since the early 1970s — and carried it forward by providing nationwide support paired with a dedication to local communities. Every independent Kubota dealership makes it a point to know and understand the people and industry they serve.

---

### **FINANCING AND WARRANTY THAT WORKS.**

We offer a range of financing options to help you. Enjoy low financing rates on the M8 Series or the option to lease. Plus we offer a limited warranty for two years, with extended warranties available.

Visit us online or visit your local Kubota dealership to get started.





# SPECIFICATIONS

TRACTOR		M8-181	M8-201	
<b>ENGINE</b>	Engine	B6.7 Tier 4 Final / Stage V		
	Manufacturer	Cummins		
	Displacement	ℓ 6.7		
	No. of Cylinders	6		
	Aftertreatment	DOC+SCR+DPF		
	Fuel Tank Capacity	gal. (ℓ)	99 (375)	
	Def Tank Capacity	gal. (ℓ)	9 (35)	
<b>PERFORMANCE</b>	Rated Engine Horsepower* @ 2100 Engine RPM	HP 180	200	
	Responsive Power Delivery	Additional 25 HP		
	Rated PTO Horsepower* @ 2000 Engine RPM	HP 145	159	
<b>PTO</b>	Type	Electro-Hydraulically Operated		
	Rear PTO Types	540 - 6 Spline & 1000 - 21 Spline (Optional 1000 - 20 Spline)		
	Rear PTO Speeds	540/540E/1000/1000E		
	Front PTO Type - Optional	Electro-Hydraulically Operated		
	Front PTO	1000 - 21 Spline, Clockwise		
<b>TRANSMISSION</b>	Semi-Powershift	30F x 15R - 6 Powershifts x 5 Ranges		
	KVT	CVT		
	Max. Traveling Speed	MPH (km/h)	24.8 (40) (Optional 31 (50))	
<b>HYDRAULICS</b>	Hydraulic System	Closed-Centre, Load Sensing (CCLS)		
	Steering/Operating Flow	gpm (ℓ/min)	11.1 (42)	
	Standard Implement Pump Flow	gpm (ℓ/min)	31.7 (120)	
	Optional Implement Pump Flow	gpm (ℓ/min)	42.2 (160)	
	Max Flow at One EHR Remote	gpm (ℓ/min)	31.7 (120)	
	No. of Rear Remote Valves (Electronic)	3 Valves (Optional 5 Valves)		
	Power Beyond	Optional		
Trailer Brake (Hydraulic)	Optional			

TRACTOR		M8-181	M8-201
<b>Drawbar</b>	Category	CAT III (Optional CAT IIIHD)	
<b>Rear 3-Pt Hitch</b>	Category	CAT III/IIIN	
	Lift Cap, 24" Behind Lift Points (OECD)*	lbs. (kg)	11200 (5080)
	Optional: Lift Capacity (OECD)*	lbs. (kg)	13600 (6170)
	Ball Ends	Standard	
	Hook Ends	Optional	
<b>Front 3-Pt Hitch</b>	Factory Installed	Optional	
	Lift Capacity at Hooks (OECD)*	lbs. (kg)	8818 (4000)
<b>Front Axle</b>	Rigid Limited Slip Differential	Standard	
	Suspended Full Locking Differential	Optional	
	Rigid Full-Locking Differential	Optional	
	Turning Angle	55°	
<b>Rear Axle</b>	Bar Axle 4.13"x 98" (105mm x 2489mm) Overall Length	Standard	
	Bar Axle 4.13" x 118" (105mm x 2997mm) Overall Length	Optional	
<b>Cabin</b>	7" K-Monitor	Standard	
	12" K-Monitor Pro	Optional	
	High Visibility Roof Panel	Standard	
	Seat Fabric - Air Suspension	Standard	
	Seat Fabric - Semi-Active	Optional	
	Seat Leather - Semi-Active Heat and Air Conditioned	Optional	
	Radio Ready	Standard	
	Cab Suspension	Optional Semi-Active Electro - Hydraulic	
	Exterior Lighting	Standard 8 Halogen (Optional 12 Halogen)	
	LED Lighting	Optional 12 LED	
<b>Measurement</b>	Wheel base	in. (mm)	114 (2895)
	Avg Shipping Weight	lbs. (kg)	Semi-Powershift transmission: 17570 (7974); KVT transmission: 18498 (8391)
	Height	in. (mm)	128 (3250)

\*Factory estimated rating. Kubota Tractor Corporation and Kubota Canada Ltd. reserve the right to change the stated specifications without notice. This material is for descriptive purposes only and reasonable efforts were used to set forth the contained information; some items shown may be optional and some products shown may not be available at all dealerships. Kubota disclaims all representations and warranties, express or implied, or any liability from the use of this material. For complete warranty, safety and product information, consult your local Kubota dealer and the operator's manual. Power (HP/KW) and other specifications are based on various standards or recommended practices. For your safety, Kubota strongly recommends the use of a Rollover Protective Structure (ROPS) and seat belt in almost all applications. This material is intended for the United States, US territories, and Canada only. For information regarding Kubota products or services outside these areas, see Kubota Corporation's global web site. Kubota does not provide parts, warranty or service for any Product which is re-sold or retailed in any country other than the country for which the Product(s) were designed or manufactured.