 **WARNING:** Cancer and Reproductive Harm - www.P65warnings.ca.gov

Operating manual

Translated from the original instruction manual

Revision	04
Date printed	02.2021
Language	EN-US
Machine number	KT483189
Document number	A132380040
Index	2019-10

Machine identification

In order for your dealer to assist you as efficiently as possible, you will need to provide some information about your machine. Please enter the details here.

Designation DMC 8028T/R-8032T/R-8532T/R-8036T/R-8536T/R-8540T/R-8547T/R

Operating width 8028: 2.8 m (9') // 80-8532: 3.2 m (10.5')
80-8536: 3.6 m (12') // 8540: 4.0 m (13') // 8547: 4.7 m (15.5')

Weight See section on "Specifications"

Machine number

Accessories

Address of supplier

Address of manufacturer Kverneland Group Kerteminde AS
Taarupstrandvej 25
DK -5300 Kerteminde - Denmark
Tel./fax: +45 65 19 19 00 / +45 65 19 19 99
web: www.kvernelandgroup.com

Table of contents

Preface	5	Transport on public roads	101
Target group for the Instruction Manual	5	Safety	101
The meaning of the symbols	6	Before traveling on public roads	101
Blank page	8	Safety chain	102
Safety	9	Check	103
For your own safety	9	Traveling on public roads	103
Who can operate the machine?	15	Cleaning	104
General safety directions	15	Before cleaning	104
Attachment	17	Cleaning	105
Hydraulics	19	After cleaning	105
Load capacity	21	Parking and Storage	106
Transport on public roads	22	Before storage	106
Use	24	Parking/disconnection	106
Disconnection	27	Storage	108
Maintenance	28	Maintenance	109
Further safety instructions	30	For your own safety	109
The machine	31	General instructions	111
Areas of use	31	Maintenance intervals	112
Characteristics	32	P.T.O. shaft check	113
Synopsis	33	After 50 hours of operation	115
Dimensions	34	Daily	116
Weight	36	Every 200 hours of operation	129
Specifications	37	As required	147
Tractor requirements	41	P.T.O. shaft	163
Preparation	42	Friction clutch	163
Preparing the machine	42	Accumulator	163
Length of P.T.O. shaft	43	Extra equipment	164
User manual for the P.T.O. shaft	43	Bx-equipment	164
Swivel gear	45	Spreading device	164
Attachment	51	Skids	165
Attachment of the tractor	51	Stubble height	165
Safety chain	56	EXPRESS	166
Lighting equipment	57	Throwing wings	166
Hydraulics	59	RPM of rotor	167
Initial start	61	RPM of rollers	169
Transport position	63	Chain	170
Operation	67	P.T.O. shaft	170
Safety	67	Hour counter	170
Working position	68	Troubleshooting	171
Conditioner	69	Hydraulic system	171
Rotor	74	Cutterbar	171
Rollers	77	P.T.O. shaft	173
Deflector plates	87	Warranty	174
Stubble height	88	Guidelines for warranty	174
Balancing	93	Disposal	175
Working in the field	95	Metal parts	175
		Rubber parts	175
		Plastic	175
		Hydraulic Oil	175
		Electronic parts	175

Table of contents

Notes	176
Technical information	177
Conversion table	177
Lubricants	177
Torque moment	178
Index	179

Target group for the Instruction Manual



NOTICE

Simplified illustrations to improve understanding

All of the illustrations of the machine in this instruction manual show it without the guards or with the protective equipment open to improve understanding. Ensure that the safety instructions are complied with and the instructions in the instruction manual are followed. Failure to do so can endanger lives.

This manual is intended for trained farmers and others who are qualified to work in agriculture and who are familiar with assembling equipment.

Minimum age

Children under the age of 16 are not permitted to operate the machine.

For your own safety

Read this instruction manual thoroughly prior to assembly and use of the machine. This will allow you to work under optimal conditions and in safety.

For the employer

Every employee must be trained in how to use this machinery at regular intervals (at least once a year) in accordance with the employer's insurance guidelines. Untrained or unauthorized persons must not use this machine.

Instructions

Your dealer will assist you with the instructions on how to use and maintain this machinery.

Preface

The meaning of the symbols

We have used different symbols to make the text clear. An explanation follows:

- A dot symbol marks a list of instructions or information.
- ▶ A triangle marks an action you must carry out.
- An arrow refers you to other parts of the text.

We have also used pictograms to help you find relevant places in the text.



Denotes tips or instructions on use.



Denotes information that requires particular attention.



A spanner indicates tips for assembling and settings.



This pictogram indicates that the tractor can be started.



This pictogram indicates that the tractor must be stopped, the handbrake applied and the ignition key removed.

California Proposition 65

WARNING

Operation, servicing and maintenance of off-road equipment and off-road vehicles can expose you to inhalation of or contact with chemicals, including engine exhaust, carbon monoxide, phthalates and lead, which is known in the state of California to cause cancer and birth defects and other reproductive injuries. In order to minimize exposure:

- Avoid inhaling exhaust gas
- Always start and operate the engine in a well-ventilated location.
- If you are in an enclosed location, the exhaust gas must be led outside.
- Never modify or rebuild the exhaust system.
- Never let the engine run idle unless it is necessary.
- Service your equipment or vehicle in a well-ventilated location.
- Use protective gloves or wash your hands often when you are servicing your equipment or vehicle.

For more information, refer to: www.P65warnings.ca.gov

SAFETY FIRST

This symbol, the industry's "Safety Alert Symbol", is used throughout this manual and on labels on the machine itself to warn of the possibility of personal injury. Read these instructions carefully. It is essential that you read the instructions and safety regulations before you attempt to assemble or use this unit.

DANGER:

Indicates an imminently hazardous situation which, if not avoided, will result in death or serious injury.

WARNING:

Indicates a potentially hazardous situation which, if not avoided, could result in death or serious injury.

CAUTION:

Indicates a potentially hazardous situation which, if not avoided, could result in minor or moderate injury.



For your own safety

Get to know your equipment and its limitations. Read the entire manual before attempting to start and operate the device.

This chapter includes general safety instructions. In addition, each chapter in the instruction manual includes specific safety instructions not set out here. The safety instructions must be followed

- For your own safety.
- For the safety of others.
- To ensure the safety of the machine.

When working with agricultural machinery, incorrect handling can pose a number of dangers. Therefore, you should always be very careful and never rush your work under pressure.

The operator must be receive regular training

Make sure that persons working with the machine are regularly reminded of these safety instructions. The safety instructions should be followed in accordance with local statutes concerning agricultural machines.

Safety



Safety labels

On the machine, you will find labels relating to your safety. These labels must not be removed. If the labels become illegible or detached, new labels can be ordered and affixed in the appropriate areas.

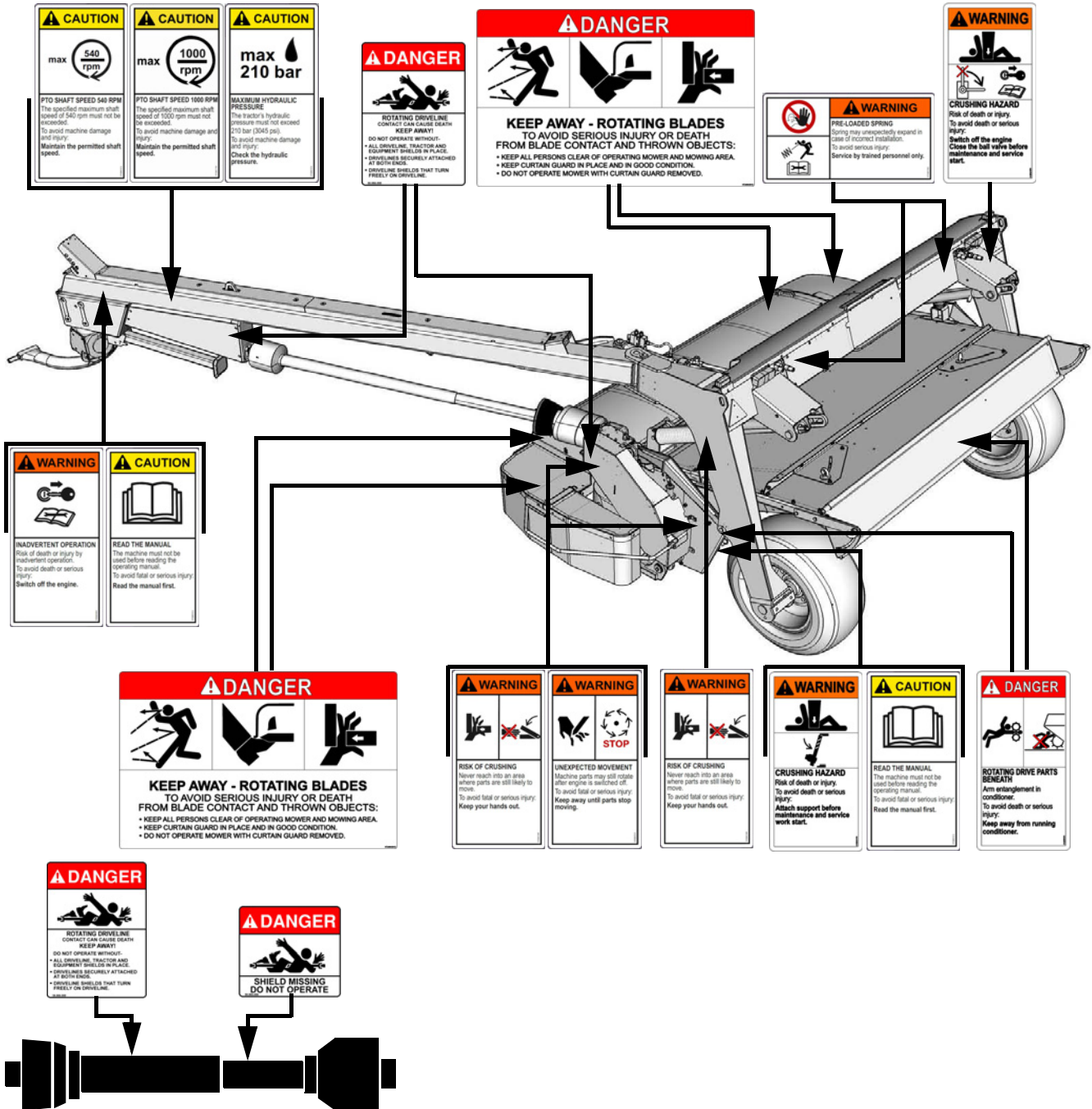



CAUTION	CAUTION	CAUTION
max 540 rpm	max 1000 rpm	max 210 bar
PTO SHAFT SPEED 540 RPM The specified maximum shaft speed of 540 rpm must not be exceeded. To avoid machine damage and injury. Maintain the permitted shaft speed.	PTO SHAFT SPEED 1000 RPM The specified maximum shaft speed of 1000 rpm must not be exceeded. To avoid machine damage and injury. Maintain the permitted shaft speed.	MAXIMUM HYDRAULIC PRESSURE The tractor's hydraulic pressure must not exceed 210 bar (3045 psi). To avoid machine damage and injury. Check the hydraulic pressure.

⚠ DANGER

ROTATING DRIVELINE CONTACT CAN CAUSE DEATH. KEEP AWAY!

DO NOT OPERATE WITHOUT:

- ALL DRIVELINE, TRACTOR AND EQUIPMENT SHIELDS IN PLACE.
- DRIVELINE SECURELY ATTACHED AT BOTH ENDS.
- DRIVELINE SHIELDS THAT TURN FREELY ON DRIVELINE.

⚠ DANGER

KEEP AWAY - ROTATING BLADES
TO AVOID SERIOUS INJURY OR DEATH FROM BLADE CONTACT AND THROWN OBJECTS:

- KEEP ALL PERSONS CLEAR OF OPERATING MOWER AND MOWING AREA.
- KEEP CURTAIN GUARD IN PLACE AND IN GOOD CONDITION.
- DO NOT OPERATE MOWER WITH CURTAIN GUARD REMOVED.

⚠ WARNING

PRE-LOADED SPRING
 Spring may unexpectedly expand in case of incorrect installation.
 To avoid serious injury. Service by trained personnel only.

⚠ WARNING

CRUSHING HAZARD
 Risk of death or injury.
 To avoid death or serious injury. Switch off the engine. Close the bail valve before maintenance and service start.

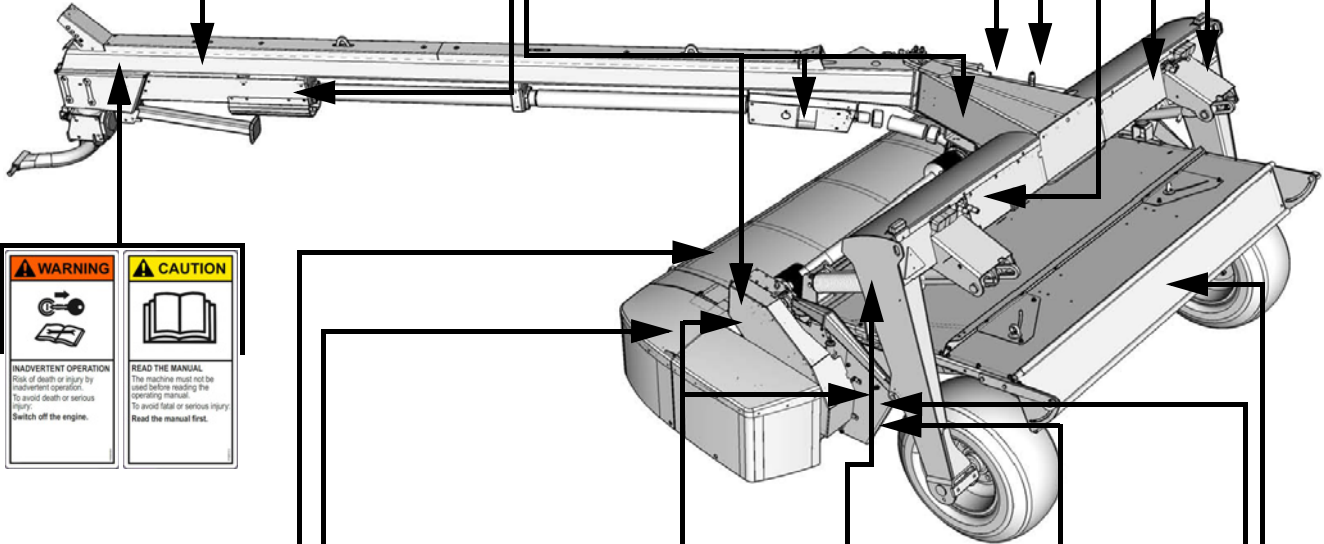

⚠ WARNING	CAUTION
INADVERTENT OPERATION Risk of death or injury by inadvertent operation. To avoid death or serious injury. Switch off the engine.	READ THE MANUAL The machine must not be used before reading the operating manual. To avoid fatal or serious injury. Read the manual first.

⚠ DANGER

KEEP AWAY - ROTATING BLADES
TO AVOID SERIOUS INJURY OR DEATH FROM BLADE CONTACT AND THROWN OBJECTS:

- KEEP ALL PERSONS CLEAR OF OPERATING MOWER AND MOWING AREA.
- KEEP CURTAIN GUARD IN PLACE AND IN GOOD CONDITION.
- DO NOT OPERATE MOWER WITH CURTAIN GUARD REMOVED.

⚠ WARNING

RISK OF CRUSHING
 Never reach into an area where parts are still likely to move.
 To avoid fatal or serious injury. Keep your hands out.

⚠ WARNING

UNEXPECTED MOVEMENT
 Machine parts may still rotate after engine is switched off.
 To avoid fatal or serious injury. Keep away until parts stop moving.

⚠ WARNING

RISK OF CRUSHING
 Never reach into an area where parts are still likely to move.
 To avoid fatal or serious injury. Keep your hands out.

⚠ WARNING

CRUSHING HAZARD
 Risk of death or injury.
 To avoid death or serious injury. Attach support before maintenance and service work start.

CAUTION

READ THE MANUAL
 The machine must not be used before reading the operating manual.
 To avoid fatal or serious injury. Read the manual first.

⚠ DANGER

ROTATING DRIVE PARTS BENEATH
 Arm entanglement in conditioner.
 To avoid death or serious injury. Keep away from running conditioner.

⚠ DANGER

ROTATING DRIVELINE CONTACT CAN CAUSE DEATH. KEEP AWAY!

DO NOT OPERATE WITHOUT:

- ALL DRIVELINE, TRACTOR AND EQUIPMENT SHIELDS IN PLACE.
- DRIVELINE SECURELY ATTACHED AT BOTH ENDS.
- DRIVELINE SHIELDS THAT TURN FREELY ON DRIVELINE.

⚠ DANGER

SHIELD MISSING DO NOT OPERATE





⚠ DANGER

		
---	--	---

KEEP AWAY - ROTATING BLADES
 TO AVOID SERIOUS INJURY OR DEATH
 FROM BLADE CONTACT AND THROWN OBJECTS:

- KEEP ALL PERSONS CLEAR OF OPERATING MOWER AND MOWING AREA.
- KEEP CURTAIN GUARD IN PLACE AND IN GOOD CONDITION.
- DO NOT OPERATE MOWER WITH CURTAIN GUARD REMOVED.

⚠ DANGER



**ROTATING DRIVELINE
 CONTACT CAN CAUSE DEATH
 KEEP AWAY!**

DO NOT OPERATE WITHOUT-

- ALL DRIVELINE, TRACTOR AND EQUIPMENT SHIELDS IN PLACE.
- DRIVELINES SECURELY ATTACHED AT BOTH ENDS.
- DRIVELINE SHIELDS THAT TURN FREELY ON DRIVELINE.

56.966.000



⚠ DANGER



**SHIELD MISSING
 DO NOT OPERATE**

56.969.000

⚠ DANGER

	
---	---

**ROTATING DRIVE PARTS
 BENEATH**
 Arm entanglement in
 conditioner.
 To avoid death or serious
 injury:
**Keep away from running
 conditioner.**



	WARNING
	<p>PRE-LOADED SPRING Spring may unexpectedly expand in case of incorrect installation. To avoid serious injury: Service by trained personnel only.</p>

WARNING
<p>CRUSHING HAZARD Risk of death or injury. To avoid death or serious injury: Attach support before maintenance and service work start.</p>

WARNING
<p>CRUSHING HAZARD Risk of death or injury. To avoid death or serious injury: Switch off the engine Close the ball valve before maintenance and service start.</p>

WARNING
<p>UNEXPECTED MOVEMENT Machine parts may still rotate after engine is switched off. To avoid fatal or serious injury: Keep away until parts stop moving.</p>

WARNING
<p>INADVERTENT OPERATION Risk of death or injury by inadvertent operation. To avoid death or serious injury: Switch off the engine.</p>

WARNING
<p>RISK OF CRUSHING Never reach into an area where parts are still likely to move. To avoid fatal or serious injury: Keep your hands out.</p>

CAUTION
<p>READ THE MANUAL The machine must not be used before reading the operating manual. To avoid fatal or serious injury: Read the manual first.</p>

CAUTION
<p>max 210 bar</p>
<p>MAXIMUM HYDRAULIC PRESSURE The tractor's hydraulic pressure must not exceed 210 bar (3045 psi). To avoid machine damage and injury: Check the hydraulic pressure.</p>

CAUTION
<p>max 1000 rpm</p>
<p>PTO SHAFT SPEED 1000 RPM The specified maximum shaft speed of 1000 rpm must not be exceeded. To avoid machine damage and injury: Maintain the permitted shaft speed.</p>

CAUTION
<p>max 540 rpm</p>
<p>PTO SHAFT SPEED 540 RPM The specified maximum shaft speed of 540 rpm must not be exceeded. To avoid machine damage and injury: Maintain the permitted shaft speed.</p>

Safety



Lighting and reflective equipment

The machine is equipped with lighting and reflective devices as a standard, which serve to ensure safety on the roads. Lighting and reflective equipment shall be in good and sound condition at all times. Lights and labels must not be removed from the machine. Illegible or missing labels must be replaced. You can get new labels as spare parts from your dealer.

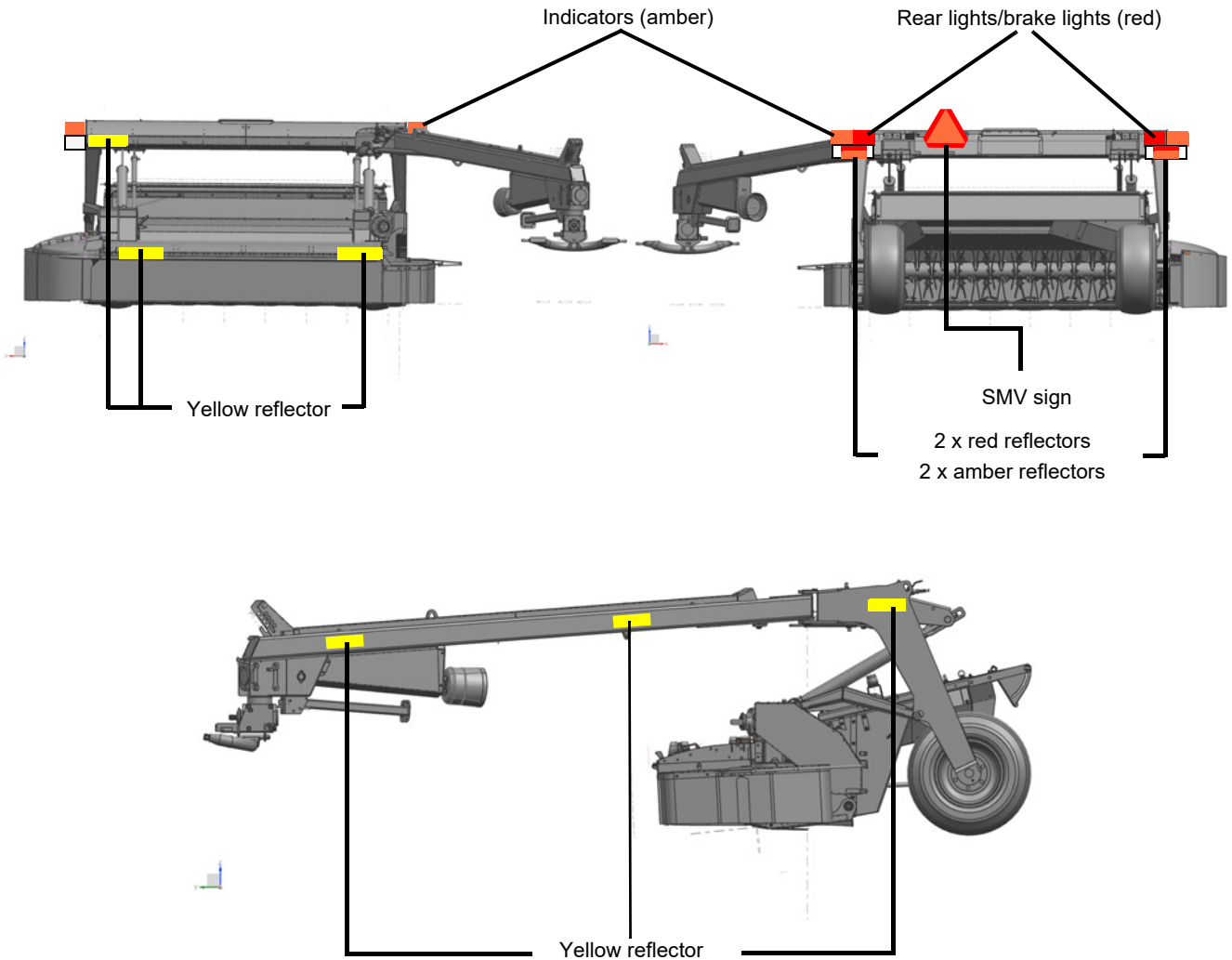

Transport on public roads



This machine must be transported on public roads **at speeds of less than 40 km/h (25 mph) only.**

→ »Speed when driving on public roads« Page 103



Who can operate the machine?

Qualified machine operators

Children under 16 years of age must not operate the machine. The machine may only be operated, maintained and repaired by persons with the required qualifications and who are informed of the risks associated with the handling of the machinery. The necessary knowledge is conveyed within the framework of an agricultural education, a professional education or through intensive instruction.

General safety directions

The operator must be receive regular training

Periodically inform those working with the machine about these safety instructions. The safety instructions should be followed in accordance with local statutes concerning agricultural machines.



Stop the tractor and make sure to secure it

Before you get out:

- Stop the tractor.
- Remove the ignition key.
- Secure the tractor to prevent it from rolling.

If a tractor is not secured, it can roll on top of up or squeeze you. In this case, you may be seriously injured and these injuries can be deadly!

The operator should receive careful instructions before using the machine

The machine should only be used if the operator has been given thorough instructions. Thorough machine instruction allows safe usage.

Insufficient training may lead to incorrect usage of the machine and accidents.

Safety is your responsibility

Observe the safety directives. You must insist that the safety directives be maintained. Complying with the safety directives will help to avoid serious or fatal accidents.

Carrying passengers on the machine is prohibited

It is dangerous and illegal to carry passengers on the machine.

The machine is not approved for personal transportation. Transporting persons on the machine may result in serious injuries and death.

Recommended work clothing

Do not wear loose-fitting clothing. Wide or loose-fitting clothing can get caught by rotating parts. Wear the kind of work and protective clothing that industry and professional organizations recommend.

Otherwise, you may be seriously injured and these injuries can be deadly.



Check and clear the surrounding area before starting to use machine

Before driving and using the machine the surrounding area should be checked and cleared. This prevents persons and animals in the vicinity from being harmed. If the surrounding area is not checked, it may result in serious injuries to persons or animals.

Keep away from the machine

No bystanders should be close to the machine when active. This will ensure that no dangerous situations can arise. Persons close to the machine during operation are at risk of being severely injured.

Never perform service or maintenance work on the machinery while it is running

One must not perform service and maintenance work of any kind to the machinery while it is running. People or objects can be carried away and dragged into the machine, or can get crushed. In this case, you may be seriously injured and these injuries can be deadly.

Safety for children

Never assume that children will remain where you last saw them. Be alert and shut your machine down if children is in the work area. Never allow children to play on or operate the machine.

Comply with the service and maintenance intervals given in the instructions

Comply with the intervals for service and maintenance as given in the instructions. By complying with the maintenance intervals, you ensure that the machine will operate without malfunctions and provide maximum protection for the environment. Poorly maintained machinery poses a danger to the surroundings.



Attachment

Correct attachment of the machine

The machine must be correctly attached according to the instructions. The machine can become detached from the tractor if the attachment is not done properly. Incorrect attachment can lead to accidents.

When attaching the machine to the tractor you must therefore:

- Make sure that the tractor cannot roll.
- Make sure that the tractor and the machine belong to the same category.
- Never stand between the tractor and the machine during attachment.
- Use the hydraulic three point suspension slowly and carefully.

Adherence to the above instructions will ensure your own safety and that of others. Failure to follow the above instructions may result in serious injury.

Make the electrical connection after attachment

When you connect the lighting equipment, the tractor must be stopped, the ignition key removed and all the lights turned off. This will prevent short circuits and damage to the electric circuit. There may be a danger of short circuiting of the electrical circuitry.

P.T.O. shaft check

Refer to the manufacturer's user manual included with the P.T.O. shaft. Here you will find instructions on the correct RPM for the P.T.O. shaft. If you ignore this information, it may result in damage to the P.T.O. shaft and to the machinery.



Be careful when working around the P.T.O shaft

When working on the P.T.O. shaft, the tractor's P.T.O. outlet must be disconnected, the tractor must be stopped and the ignition key removed. This prevents the PTO shaft from suddenly starting to rotate. If the tractor and the P.T.O. shaft have not been connected in accordance with the instructions, serious accidents causing injury to limbs can occur.

Use the recommended P.T.O. shaft

Only use the P.T.O. shaft that the manufacturer has recommended.

- Read the accompanying operating guidelines carefully. Failure to do so may result in damage to the machinery or serious or fatal injuries.
- If necessary, adjust the lengths of the P.T.O. shaft. A wrong length on a P.T.O. shaft can result in damages to the machinery and injuries to persons.
- Other PTO shafts with deactivation couplings can allow higher disconnection torques. Higher disconnection torques can cause damage to the machinery.

Checking and fastening the screens to the P.T.O. shaft

The rotating P.T.O. shaft is protected by the screen. Make sure that the screens are intact. Attach the screens for the P.T.O. shaft to both tractors and equipment with chains. An unprotected P.T.O. shaft can cause life-threatening injuries.



Hydraulics

Only connect the hydraulics when the system is depressurized

You should only connect the hydraulic hoses to the tractor's hydraulics when the hydraulic system on both the tractor and the machine is depressurized. There is a risk that the machine will move accidentally. Unintentional movement of the machine may result in serious injuries.

Hydraulic oil under pressure can cause serious injuries

Before connecting hydraulic connections, all excess pressure must be released. Hydraulic oil under pressure can penetrate the skin and result in serious injuries. Before connecting the hydraulic system, you must ensure that all connections are tight and that all pipes and hoses are not damaged.

Increased pressure in the hydraulic system

The hydraulic system is under high pressure. Regularly check all conduits, hoses and fittings for visible damage. Only use appropriate aids when searching for leaks. Rectify damages with the same. Leaking oil can cause injuries or fire. Immediately contact a physician in case of accidents.

Never use your fingers or hands to check for leaks

Never use your fingers or hands to check the hydraulic system for leaks. Use a piece of paper or cardboard to check the hydraulic system for leaks. Leaking pressurized oil can cause serious injuries to skin and cause gangrene.



Replacing the hydraulic hoses

Replace the hydraulic hoses at least once every 6 years. Hydraulic hoses also wear without any visible damage. Only use hydraulic hoses with the same technical specifications. The necessary data are printed on the hydraulic hose. Defective hydraulic hoses may cause serious injury or death.

Avoid physical contact with hydraulic oil

Hydraulic oil contains additives that under certain circumstances can have serious consequences for your health. Therefore, when handling hydraulic oil be aware of the following:

- Avoid direct contact with hydraulic oil. It can cause injuries to the skin.
- Protect your skin with barrier cream or protective gloves.
- Never use oil or lubricants to clean your hands.
- Clothes contaminated with oil should be changed immediately.
- Oily cloths should not be kept in your pockets.
- Seek medical help for skin injuries or if you come into contact with hydraulic oil under pressure, as such injuries can cause gangrene.

Color markings of the hydraulic connections

The hydraulic connections between the tractor and the machine must be marked in different colors. By color marking the hydraulic connections, you avoid wrong operation of the machine. Incorrect operation or unintentional movement of the machine may result in serious injuries.



Load capacity

Compliance with total weight, axle pressure, carrying capacity of the tires and minimum weight on the tractor

Neither the tractor's total weight, axle pressure or the carrying capacity of the tires may be exceeded on front/mounted and rear-mounted machines. To ensure the maneuverability of the tractor, the load on the front axle must be at least 20% of the tractor's weight. Failure to do so can result in a loss of control and cause accidents.

Weight/power ratio between machine and tractor

The machine may only be connected to a tractor of the correct size and power.

The tractor's size and P.T.O. outlet must correspond to the power consumption of the machine and its weight. Wrong weight/power ratio can result in damage to both machine and tractor.



Transport on public roads

Make sure that the machinery complies with all national and local requirements for transport on public roads

When driving on public roads, the machine must comply with the Road Traffic Act's current requirements. This ensures your safety and that of other road users. Failure to meet the requirements can result in accidents.

Compliance with the Road Traffic Act's current requirements includes, for example:

- Installation of lights, warning and safety equipment.
- Compliance with permitted transport width, weight, axle pressure, tire carrying capacity and total weight.
- Keep to the maximum allowable transport speed.
- Secure the machine.

The tractor's dead weight must be greater than the machine's weight. Violations can result in the driver and the owner of the vehicle being held responsible.

Keep away from high voltage lines

Upon heights exceeding 4 meters, there is a great danger that the machine will come too close to or in direct contact with high-voltage lines. Keep a safe distance away from high-voltage lines! Insufficient distance from high-voltage lines may result in serious injuries and death.

Keep away from thunderstorms and lightning strikes

Avoid driving with the machine or working on the machine in thunderstorms and/or lightning strikes. There is a high risk of being struck by lightning.

Lightning strikes can cause serious injury or death.

Danger of decreased stability when heavy attached tools are used at a high position

Drive carefully with heavy attached tools are used at a high position. There is a high risk of the machine tipping. This may result in serious injury or death.



Carrying passengers on the machine is prohibited

It is dangerous and illegal to carry passengers on the machine. The machine is not approved for personal transportation. Transporting persons on the machine may result in serious injuries and death.

Attached machines change the driving and braking abilities of the tractor

Be aware of the changed driving and braking abilities when driving with machines attached. You should be especially aware of the machine's width and length when driving around bends and turns. Serious accidents and a loss of control may result if this is not taken into account.

Adjust the speed according to the road conditions

Adjust driving speed according to the conditions on the road. Poor road conditions and high speeds can lead to parts of the tractor and machine being overloaded. Driving too fast can lead to accidents and damage both the machine and the tractor.



Use

Keep away from thunderstorms and lightning strikes.

Avoid driving with the machine or working on the machine in thunderstorms and/or lightning strikes. There is a high risk of being struck by lightning.

Lightning strikes can cause serious injury or death.

Danger of decreased stability when heavy attached tools are used at a high position

Drive carefully with heavy attached tools are used at a high position. There is a high risk of the machine tipping. This may result in serious injury or death.

There is a danger of tipping when driving on sloping or uneven terrain

Never drive at high speeds on sloping or uneven terrain. There is a high risk of the machine tipping. This may result in serious injury or death.

Check that the machine has no technical faults

Only use the machine if it has no technical faults. This ensures that the machine is operating correctly and safely. A machine with technical faults and defects can be dangerous and inappropriate to use.

Check the safety devices

Check that all protective devices are in place before use. This ensures that the machine will give maximum protection to the operator. If the safety devices are removed or not used, it may result in serious injuries and accidents.



Carrying passengers on the machine is prohibited

It is dangerous and illegal to carry passengers on the machine. The machine is not approved for personal transportation. Transporting persons on the machine may result in serious injuries and death.

Check and clear the surrounding area before starting to use machine

Before driving and using the machine the surrounding area should be checked and cleared. This prevents persons and animals in the vicinity from being harmed. If the surrounding area is not checked, it may result in serious injuries to persons or animals.

Never perform service or maintenance work on the machinery while it is running

One must not perform service and maintenance work of any kind to the machinery while it is running. People or objects can be carried away and dragged into the machine, or can get crushed. In this case, you may be seriously injured and these injuries can be deadly.

Keep away from the machine

No bystanders should be close to the machine when active. This will ensure that no dangerous situations can arise. Persons close to the machine during operation are at risk of being severely injured.

Safety for children

Never assume that children will remain where you last saw them. Be alert and shut your machine down if children is in the work area. Never allow children to play on or operate the machine.



Checking bolts on moving parts

Check that all bolts on moving parts are correctly tightened. Tightening parts prevents moving parts from jarring. Parts which are not correctly tightened can work themselves loose and damage the machine.

Maintain the correct rotational speed on the P.T.O. outlet

The recommended RPM on the P.T.O. shaft must not be exceeded. It can result in damage to the machine and be dangerous to any persons in the vicinity.

Check the transmission oil level regularly

Check that the transmission is filled with oil and that the oil level is correct. A correct oil level ensures the transmission a long and trouble free service life. An incorrect oil level will damage the transmission.

Stop the machine immediately in case of malfunction

In case of malfunction, the machine should be stopped immediately. A mechanical malfunction can endanger persons and animals in the vicinity. Malfunctioning machines can give rise to dangerous situations.

Make sure that the tractor and the machinery stand on a level surface

Make sure that the machinery stands evenly before switching it from transport to working position (and vice versa). There is a particular risk of the machine falling on slopes. Otherwise, serious damage can occur to the machine and fatal injuries to the operator.

Check the tire pressure regularly

Check the tire pressure on the tractor and machine regularly. This will ensure optimal driving conditions and prevent the accidental lifting of the tractor and the machine. Abnormal and uncontrollable lifting of the tractor and machine can result in accidents.



Disconnection

Increased risk of injury when disconnecting

There is an increased risk of injury when disconnecting the machine from the tractor. Adherence to the above instructions will ensure your own safety and that of others. Failure to follow the above instructions may result in serious injury.

Therefore, when disconnecting:

- Make sure that the tractor cannot roll.
- Never stand between the tractor and the machine during disconnection.
- Use the hydraulic three point suspension slowly and carefully.
- Make sure that the machine is standing on a safe, level surface.
- When depressurizing the hydraulic system for both tractor and machine, first disconnect the hydraulic hoses.

If you do not follow these instructions, it can result in serious injury or death.



Maintenance

Comply with the service and maintenance intervals given in the instructions

Comply with the intervals for service and maintenance as given in the instructions. By complying with the maintenance intervals, you ensure that the machine will operate without malfunctions and provide maximum protection for the environment. Poorly maintained machinery poses a danger to the surroundings.

Maintenance of the P.T.O. shaft

Keep to the recommended intervals for service and maintenance of the P.T.O. shaft. Refer to the manufacturer's user manual included with the P.T.O. shaft. Here you will find instructions on the correct maintenance of the P.T.O. shaft. If you ignore this information, it may result in damage to the P.T.O. shaft and to the machinery.

Always use original spare parts on the machine

Always use original spare parts. Original spare parts should be used for safety reasons. The manufacturer's warranty becomes void if non-original spare parts are used.

Never perform service or maintenance work on the machinery while it is running

One must not perform service and maintenance work of any kind to the machinery while it is running. People or objects can be carried away and dragged into the machine, or can get crushed. In this case, you may be seriously injured and these injuries can be deadly.

High risk when performing service and maintenance work

When performing service or maintenance work, there is a higher risk of injury. Paying full attention to the aforementioned point ensures your safety and that of others. Failure to pay attention to the aforementioned point may result in serious injuries.

Therefore, when you perform maintenance work:

- Disconnect the P.T.O. shaft.
- Depressurize the hydraulic system.
- Stop or disconnect the tractor.
- Check that the machine is parked safely; support it if necessary.
- Do not use parts of the machine to climb onto it; the correct climbing devices must be used.
- Make sure that the machine can not tip over.



Disconnect the power source when working on the electrical systems

Always disconnect the negative terminal to the battery before working with the electrical system. This will prevent short circuits and damage to the electric circuit.

Be careful when cleaning with high pressure cleaning equipment

Only use low-pressure cleaning equipment to clean bearings, hydraulic hoses, plastic components, electrical control boxes and electrical equipment. Using low water pressure to clean will protect the sensitive equipment on the machine. Using high water pressure to clean could damage vital parts of the machine.

No harsh cleaning agents

Do not use harsh cleaning agents when cleaning. Bare metal surfaces may be damaged.

Disconnect the battery, the motor control unit and the generator before doing any welding

The tractor battery and alternator should be disconnected before performing welding work on the machine. This will protect the tractor alternator during welding work. The tractor alternator could be damaged or destroyed if the electric connections are not disconnected before welding.

Tighten all fittings on moving parts

Check that bolts on moving parts are tightened after performing maintenance work. Tightening parts prevents moving parts from jarring. Parts which are not correctly tightened can work loose and damage the machine.

Do not alter the machine construction

The technical construction of the machine should not be altered and machine maintenance should be performed. A well maintained machine will offer maximum protection.

A poorly maintained machine will not offer proper protection and could be dangerous.



Further safety instructions

Follow the instructions when working on the machine

The machine safety instructions should always be complied with. This will protect you and others from injury. Failure to follow the safety instructions may result in serious injuries.

In addition to the safety instructions, the following should be followed:

- Environmental legislation.
- The general technical, medical and road act regulations.
- Instructions in this instruction manual.
- Instructions for use, maintenance and service.

This chapter includes general information about your machine.

Areas of use

8028T/R - 8032T/R - 8532T/R - 8036T/R - 8536T/R - 8540T/R - 8547T/R is a towed harvester designed for the harvesting of commonly occurring grasses and grains. The instructions for use are given in the following chapters.

Correct usage

The machine can be used in fields for mowing the following crops:

- All types of grass
- All types of clover
- Whole seed
- Alfalfa
- Sorghum

Incorrect usage

The machine must not, under any circumstances, be used for the following:

- Cutting grass in park facilities and lawns
- Cutting grass on the boulevard strips of public roads
- Harvesting corn
- Clearing forest floors or other densely wooded areas

Similar use is outside the intended applications of the machine. The manufacturer is not liable for any damages caused by incorrect usage of the machine. The user is wholly liable for the machine.

Characteristics

Description of the machine

8028T/R - 8032T/R - 8532T/R - 8036T/R - 8536T/R - 8540T/R - 8547T/R is a towed harvester, where::

- the 80xxT/R model only operates on the right-hand side of the tractor.
- The 85xxT/R model operates on both sides of the tractor.

The machine is towed behind the tractor via a drawbar which is coupled to the tractor's lift arms. The drawbar is connected to the main frame of the machine which carries the whole machine on two (2) powerful wheels. The machine can be set in either the transport position or the working position using the drawbar which is operated using the tractor's hydraulic system.

The machine's cutting unit is hydraulically connected to the main frame of the machine and can be lowered using the tractor's hydraulic system. The cutting unit is balanced using strong springs which secure the machine's cutterbar, following the ground precisely and cutting the crop uniformly. The machine's cutting discs are equipped with durable, reversible blades, which have a high capacity when used at a high speed of rotation, even for difficult crops. Even at high mowing speeds, the machine is able to mow the crop cleanly and uniformly. For safety reasons, it is recommended that the speed not exceed 9 mph (15 km/h).

The T model is fitted with a powerful rotor that provides effective conditioning of the crop.

The R model is fitted with powerful rollers that provide effective conditioning of the crop.

The cutting unit is fitted with a guard, which protects it against moving objects. The guard, or parts of the guard, must never be removed from the machine and must always be kept in good condition.

Solid construction

Thanks to its solid construction and flexibility, the machine is both strong and reliable.

Synopsis

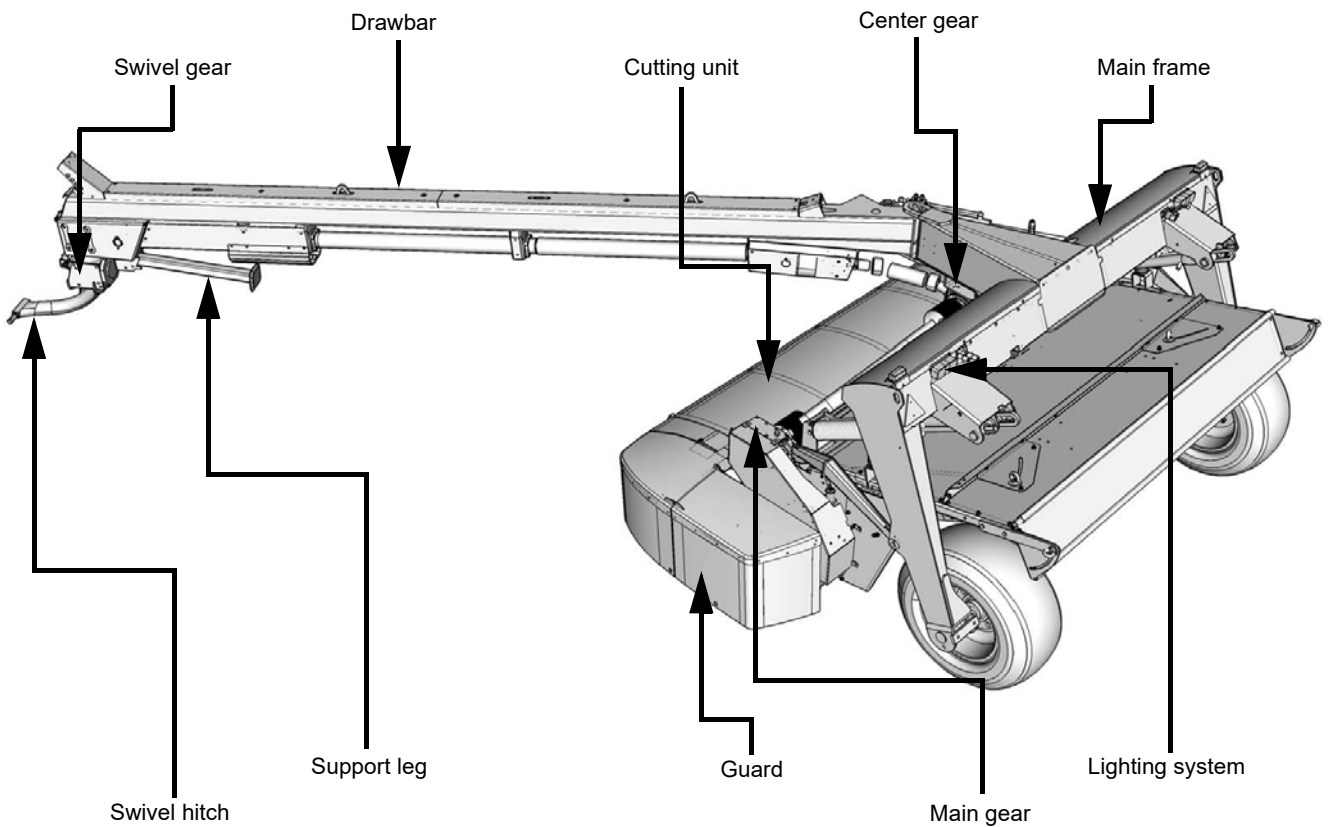
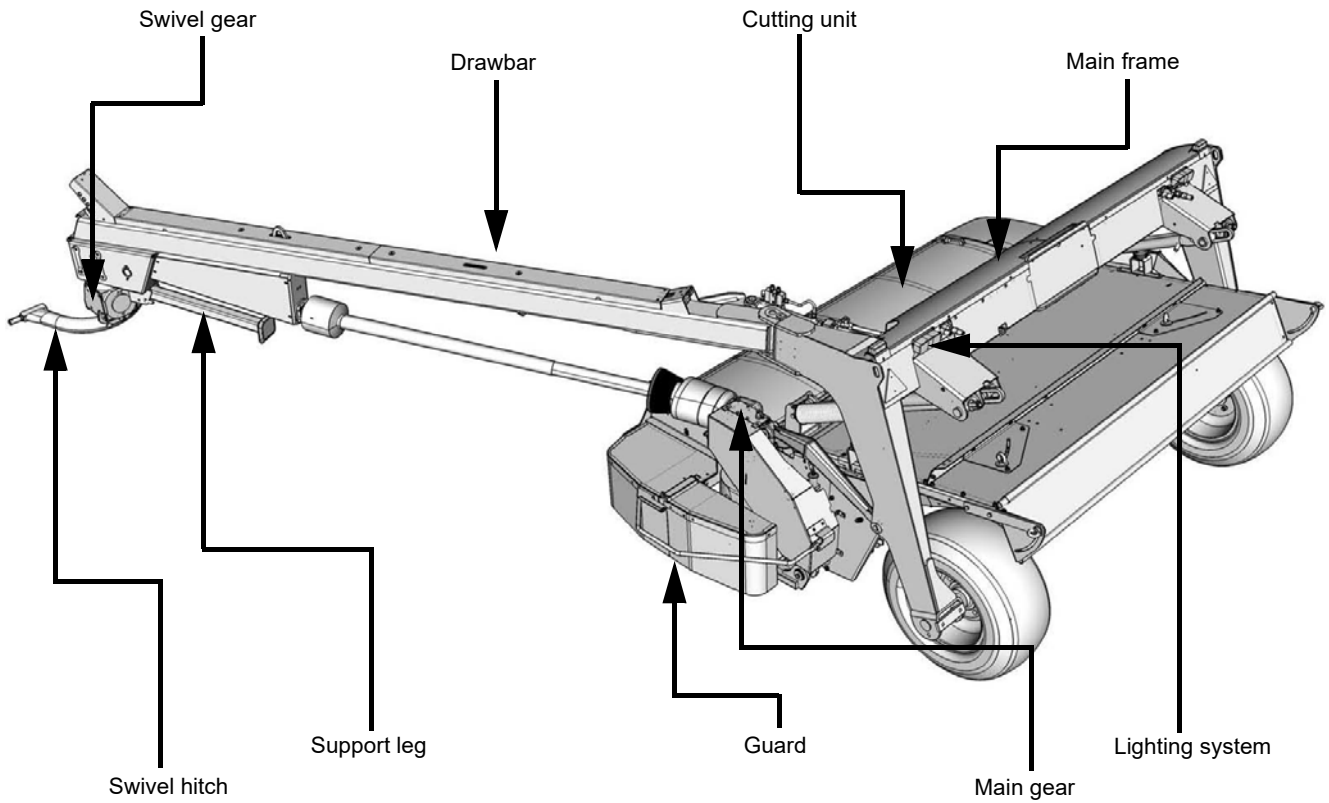

The machine

Dimensions

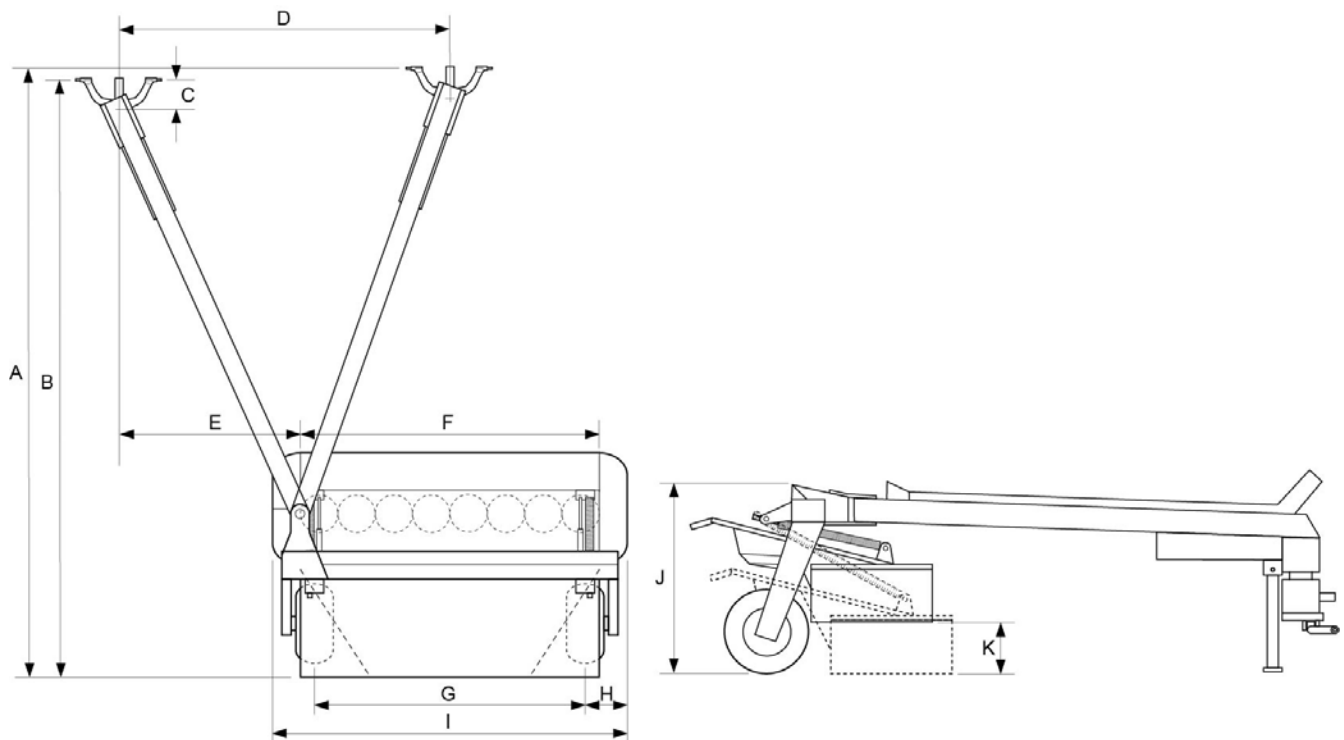

Dim.	Unit	8028T/R	8032T/R	8036T/R
A	mm / "	5360 / 211	5940 / 234	
B	mm / "	5130 / 202	5710 / 225	
C	mm / "	350 / 14		
D	mm / "	2700 / 106	3050 / 120	
E	mm / "	1200 / 47	1400 / 55	
F	mm / "	2800 / 110	3200 / 126	3600 / 142
G	mm / "	2075 / 82	2380 / 94	2780 / 109.5
H	mm / "	675 / 26.5		
I	mm / "	3450 / 136	3750 / 147.5	4150 / 163
J	mm / "	1700 / 67		
K	mm / "	425 / 17		

The machine

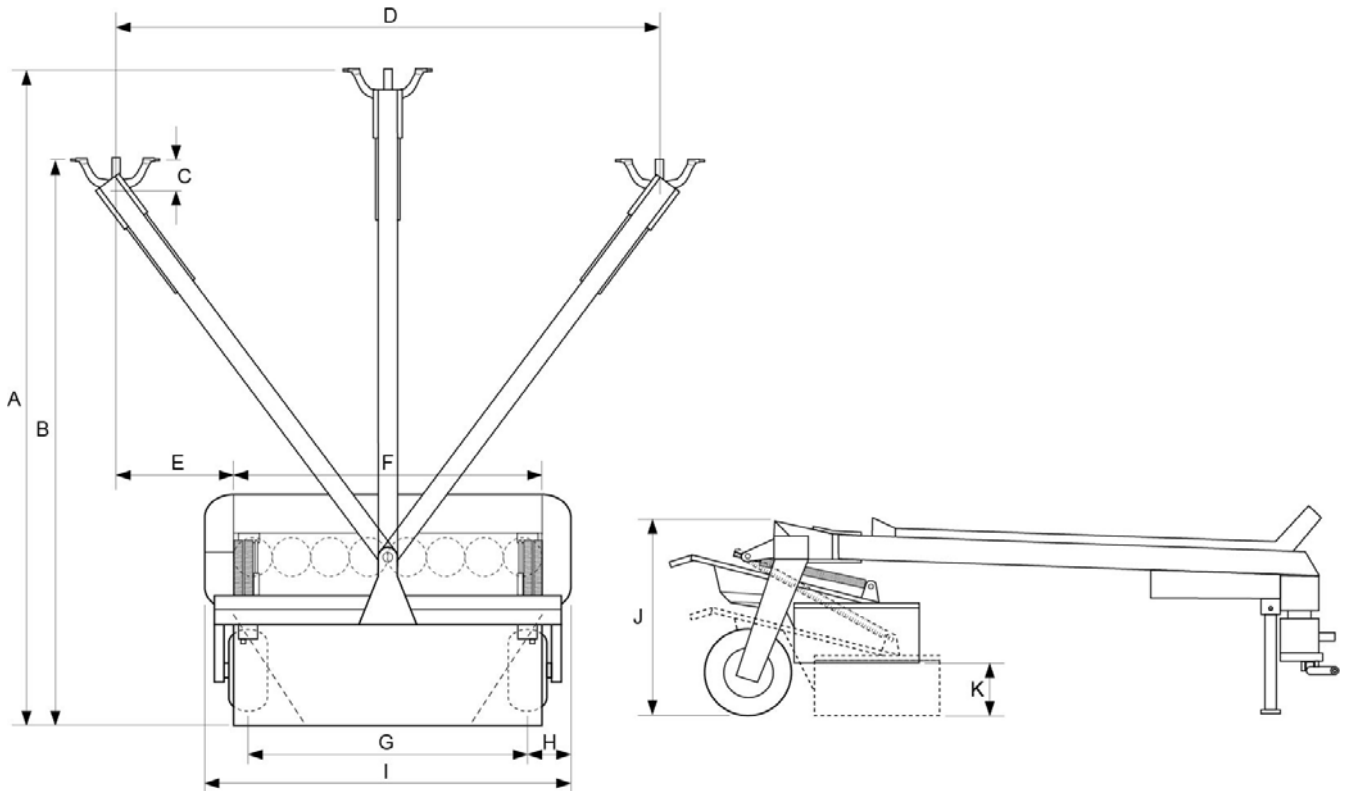

Dim.	Unit	8532T/R	8536T/R	8540T/R	8547 T/R
A	mm / "	7600 / 300		8200 / 323	9200 / 362
B	mm / "	6250 / 246	5900 / 232	6550 / 258	7560 / 297.5
C	mm / "	350 / 14			
D	mm / "	6000 / 236	6875 / 270	7400 / 291	8940 / 352
E	mm / "	1425 / 56	1650 / 65	1750 / 69	2200 / 86.5
F	mm / "	3200 / 126	3600 / 142	4000 / 157.5	4700 / 185
G	mm / "	2380 / 94	2780 / 109.5	3180 / 125	3880 / 153
H	mm / "	675 / 26.5			
I	mm / "	3750 / 147.5	4150 / 163	4650 / 183	5350 / 211
J	mm / "	1700 / 67			
K	mm / "	425 / 17			

The machine

Weight

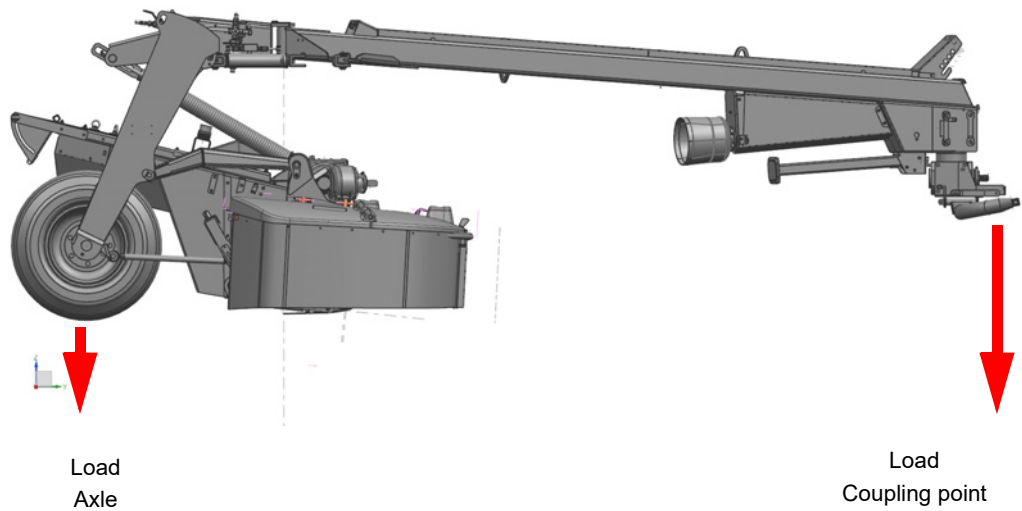

Model	Load Axle kg (lb)	Load Coupling point kg (lb)	Total weight kg (lb)
8028T	1485 (3275)	490 (1080)	1975 (4355)
8028R ³	1575 (3475)	490 (1080)	2065 (4555)
8032T	1605 (3540)	510 (1125)	2115 (4665)
8032R ³	1675 (3695)	510 (1125)	2185 (4820)
8532T	1820 (4015)	550 (1215)	2370 (5225)
8532R ³	1900 (4190)	550 (1215)	2450 (5405)
8532R ⁴	1920 (4235)	550 (1215)	2470 (5450)
8036T	1620 (3570)	530 (1165)	2150 (4735)
8036R ³	1710 (3770)	530 (1165)	2240 (4935)
8536T	1890 (4160)	560 (1235)	2450 (5395)
8536R ³	2005 (4420)	560 (1235)	2565 (5655)
8536R ⁴	2005 (4420)	560 (1235)	2565 (5655)
8540T	2070 (4565)	595 (1315)	2665 (5880)
8540R ³	2200 (4850)	595 (1315)	2795 (6165)
8547T	2640 (5820)	700 (1545)	3340 (7365)
8547R ³	2770 (6110)	700 (1545)	3470 (7655)

- ³ Rubber roller.
- ⁴ Steel roller.

Specifications

80xxT model

	Unit	8028T	8032T	8036T
Unladen weight 80xxT model	kg / lb	1975 (4355)	2115 (4665)	2150 (4735)
P.T.O. (power take off)	RPM	540/1000 ¹		
Power requirement, minimum (P.T.O. outlet)	kW	50	60	65
	HP	70	80	90
Number of cutting discs	parts	8	8	10
Number of blades	parts	24	24	30
RPM, cutting discs	RPM	3000		
RPM, rotors	RPM	500 ² /600/900/1015 ²		
Stubble height	mm / “	20-150 ² (0,8-6”) ²		
Hydraulic pressure	bar / psi	150 / 2175		
Wheel	dim	15.0/55-17		
Tire pressure	bar / psi	2.6 (37)		
Noise level	dB(A)	90		
Cutting width	m / ‘	2.8 / 9’	3.2 / 10.5’	3.6 / 12’
Driving speed	km/h / mph	6-15 (4-9)		
Transport width	m / ‘	2.7 / 9’	3.0 / 10’	3.4 / 11’

- ¹ P.T.O.

→ »Number of revolutions on the P.T.O. outlet« Page 46

- ² Extra equipment.

→ »RPM of rotor« Page 167

→ »Skids« Page 165

The machine

85xxT model

	Unit	8532T	8536T	8540T	8547T
Unladen weight 85xxT model	kg / lb	2370 (5225)	2450 (5395)	2665 (5880)	3340 (7365)
P.T.O. (power take off)	RPM	540/1000 ¹			
Power requirement, minimum (P.T.O. outlet)	kW	60	65	75	88
	HP	80	90	100	120
Number of cutting discs	parts	8	10	10	12
Number of blades	parts	24	30	30	36
RPM, cutting discs	RPM	3000			
RPM, rotors	RPM	500 ² /600/900/1015 ²			
Stubble height	mm / "	20-150 ² (0,8-6") ²			
Hydraulic pressure	bar / psi	150 / 2175			
Wheel	dim	15.0/55-17			
Tire pressure	bar / psi	2.6 (37)			
Noise level	dB(A)	90			
Cutting width	m / '	3.2 / 10.5	3.6 / 12	4.0 / 13	4.7 / 15.5
Driving speed	km/h / mph	6-15 (4-9)			
Transport width	m / '	3.0 / 10	3.4 / 11	3.8 / 12.5	4.5 / 14.7

- ¹ P.T.O.

→ »Number of revolutions on the P.T.O. outlet« Page 46

- ² Extra equipment.

→ »RPM of rotor« Page 167

→ »Skids« Page 165

80xxR model

	Unit	8028R	8032R	8036R
Unladen weight 80xxR model ³	kg / lb	2065 (4555)	2185 (4820)	2240 (4935)
P.T.O. (power take off)	RPM	540/1000 ¹		
Power requirement, minimum (P.T.O. outlet)	kW	50	60	65
	HP	70	80	90
Number of cutting discs	parts	8	8	10
Number of blades	parts	24	24	30
RPM, cutting discs	RPM	3000		
RPM, rollers	RPM	1000/750 ² /1200 ²		
Stubble height	mm / "	20-150 ² (0,8-6") ²		
Hydraulic pressure	bar / psi	150 / 2175		
Wheel	dim	15.0/55-17		
Tire pressure	bar / psi	2.6 (37)		
Noise level	dB(A)	90		
Cutting width	m / '	2.8 / 9'	3.2 / 10.5'	3.6 / 12'
Driving speed	km/h / mph	6-15 (4-9)		
Transport width	m / '	2.7 / 9'	3.0 / 10'	3.4 / 11'

- ¹ P.T.O.

→ »Number of revolutions on the P.T.O. outlet« Page 46

- ² Extra equipment.

→ »RPM of rollers« Page 169

→ »Skids« Page 165

- ³ Rubber roller.

The machine

85xxR model

	Unit	8532R	8536R	8540R	8547R
Unladen weight 85xxR model ³	kg / lb	2450 (5405)	2565 (5655)	2795 (6165)	3470 (7655)
Unladen weight 85xxR model ⁴	kg / lb	2470 (5450)	2565 (5655)	-	-
P.T.O. (power take off)	RPM	540/1000 ¹			
Power requirement, minimum (P.T.O. outlet)	kW	60	65	75	88
	HP	80	90	100	120
Number of cutting discs	parts	8	10	10	12
Number of blades	parts	24	30	30	36
RPM, cutting discs	RPM	3000			
RPM, rollers	RPM	1000/750 ² /1200 ²			
Stubble height	mm / “	20-150 ² (0,8-6”) ²			
Hydraulic pressure	bar / psi	150 / 2175			
Wheel	dim	15.0/55-17			
Tire pressure	bar / psi	2.6 (37)			
Noise level	dB(A)	90			
Cutting width	m / ‘	3.2 / 10.5’	3.6 / 12’	4.0 / 13’	4.7 / 15.5
Driving speed	km/h / mph	6-15 (4-9)			
Transport width	m / ‘	3.0 / 10’	3.4 / 11’	3.8 / 12.5’	4.5 / 14.7

- ¹ P.T.O.

→ »Number of revolutions on the P.T.O. outlet« Page 46

- ² Extra equipment.

→ »RPM of rollers« Page 169

→ »Skids« Page 165

- ³ Rubber roller.

- ⁴ Steel roller.

Tractor requirements



WARNING

Tractor weight and size

The tractor must have a proper weight. Local legislation governing this ratio must be observed. The correct ratio between tractor and machine ensures correct braking functions and maneuverability. An incorrect ratio between tractor and machine can be dangerous.

Preparation

Preparing the machine

The machine is divided into its main components for transport to the user. The machine must be assembled in accordance with the specific assembly instructions delivered with each machine.



CAUTION

Do not attempt to assemble the machine alone

Personnel must be trained before assembling the machine. Do not carry out assembly work alone. The following must be observed to ensure that the machine is in good working order:

- Adhere to the sequence of the work steps.
- Adhere to the tolerances and tightening torques of bolts, screws and component parts of the machine.
- Knowledge of occupational safety when assembling the machine.

Incorrect assembly can cause accidents or damage to the machine.



If any parts are missing or were damaged during transport, kindly contact the distributor, importer or manufacturer without delay.

Parts checklist	Number
P.T.O. shaft	2
Instruction manual	1
Spare parts manual	1
Additional parts	See packing list

Instruction manual

The instruction manual is a part of the machine and must always be kept on or at the machine.

Length of P.T.O. shaft



WARNING

Stop the tractor and secure the tractor from rolling

Before uncoupling:

- ▶ Stop the tractor.
- ▶ Remove the ignition key.
- ▶ Secure the tractor to prevent it from rolling.

Failure to secure the tractor to prevent it from rolling could endanger lives.

Correct length

If the PTO shaft is too long, it must not be used. It will damage the tractor and the machine.



The length of the PTO shaft is factory-set, and is suitable for virtually all types of tractor. The PTO will only need to be corrected in a few exceptional cases, to achieve the correct length for certain tractors. Check the length of the P.T.O. shaft on every tractor before using for the first time.

Check the length of the P.T.O. shaft



- ▶ Connect the machine to the tractor without the P.T.O. shaft.
- ▶ Stop the tractor, remove the ignition key and secure the tractor to prevent it from rolling.

Refer to the manufacturer's user manual included with the P.T.O. shaft.

User manual for the P.T.O. shaft

The P.T.O. shaft comes with a user manual from the manufacturer. The user manual contains detailed information on the version of the P.T.O. shaft in question, maintenance and a description of how the length of the P.T.O. shaft can be adjusted to the tractor.

The description and information in the user handbook must be observed.

Preparation

Shorten the P.T.O. shaft

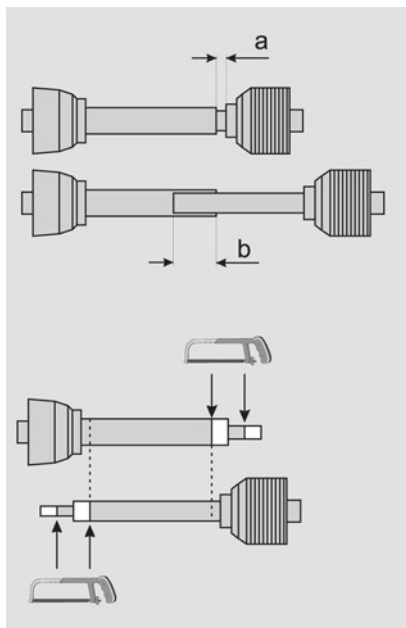

Refer to the manufacturer's user manual included with the P.T.O. shaft.

→ »User manual for the P.T.O. shaft« Page 43

a	Minimum 20 mm (0.8")
b	Minimum 200 mm (8")

Installing the P.T.O. shaft

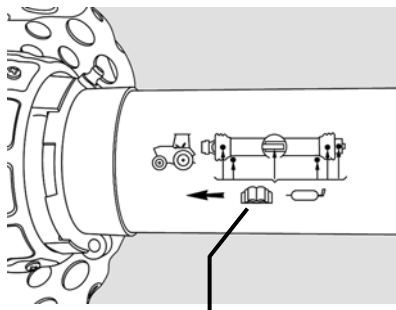

Marking of protective tubes

Make sure that you install the P.T.O. shaft in the correct position. It is shown by a marking on the P.T.O. shaft's protective tube.

- ▶ Install the P.T.O. shaft between the tractor and the machine.
- ▶ Secure the P.T.O. shaft in place with a locking pin and a safety chain.

Swivel gear

Checking the RPM

WARNING

Maintain the correct rotational speed on the P.T.O. outlet

It is dangerous to connect a tractor with a P.T.O. of 1000 RPM to a machine designed for a P.T.O. of 540 PRM. The machine is not designed for this speed. It can result in damage to the machine and be dangerous to any persons in the vicinity.

CAUTION

The swivel gear can be switched to two (2) modes, so that both rotational speeds, 540 RPM or 1000 RPM, can be used. From the factory, the machine is adapted to tractors that run at 540 RPM or 1000 RPM on the P.T.O. outlet (depending on model).

→ »Number of revolutions on the P.T.O. outlet« Page 46



Whenever possible, one should always aim to run the P.T.O. outlet at 1000 RPM. It is particularly recommended that a tractor with a power of more than 70 kW (90 hp) at the P.T.O. socket be run at 1000 RPM as a higher RPM results in less strain on the P.T.O. shaft.

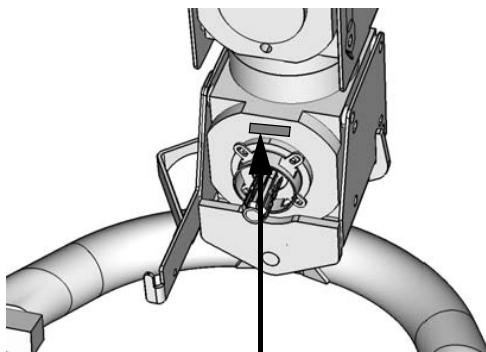

P.T.O. shaft RPM

The swivel gear's RPM can be checked in 2 ways:

The swivel gear is factory-fitted with a sign that gives the tractor's P.T.O. shaft RPM.

- If the sign shows 1000 RPM, the machine must run at a rotational speed of 1000 RPM.
- If the sign shows 540 RPM, the machine must run at a rotational speed of 540 RPM.

Preparation

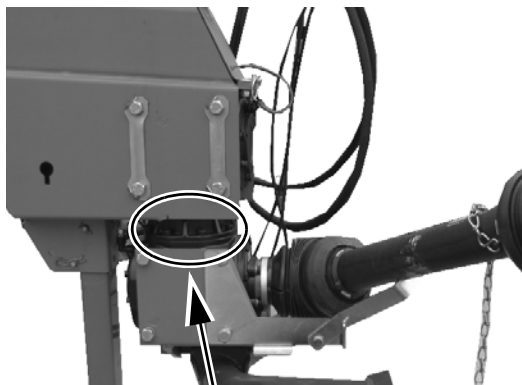

The swivel gear's RPM can also be checked by observing the transmission's pivot joint.

Check the swivel gear in the following way:

- ▶ Observe the transmission profile in the middle of the swivel gear.
- If the swivel gear's profile on the lower part of the swivel gear is wide, the machine should be run at a rotational speed of 1000 RPM.
- If the swivel gear's profile on the lower part of the swivel gear is narrow, the machine should be run at a rotational speed of 540 RPM.

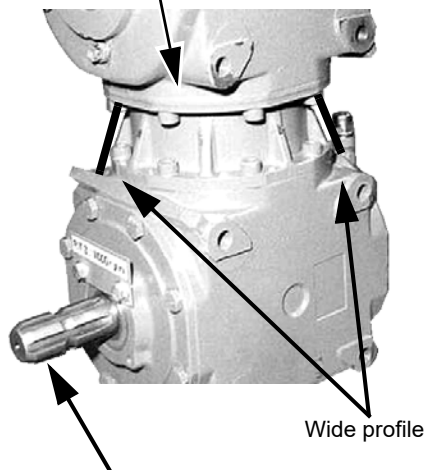

The rotational speed of the tractor's P.T.O. outlet = 1000 RPM.

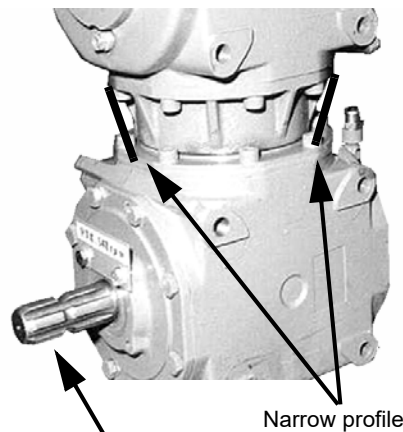

The rotational speed of the tractor's P.T.O. outlet = 540 RPM.

Number of revolutions on the P.T.O. outlet

540 RPM

From the factory, the machine is adapted to tractors that run at 540 RPM or 1000 RPM on the P.T.O. outlet (depending on model)

- DMC 8028 T/R
- DMC 8032 T/R
- DMC 8532 T/R

1000 RPM

- DMC 8036 T/R
- DMC 8536 T/R
- DMC 8540 T/R
- DMC 8547 T/R

540 to 1000 RPM or vice versa

If the machine is adapted to an RPM at the tractor's P.T.O. other than that from the factory, do the following:

- ▶ Remove the P.T.O. shaft.
- ▶ Remove the bolts and Nord-Lock discs on both sides of the transmission.
- ▶ Remove the bracket.

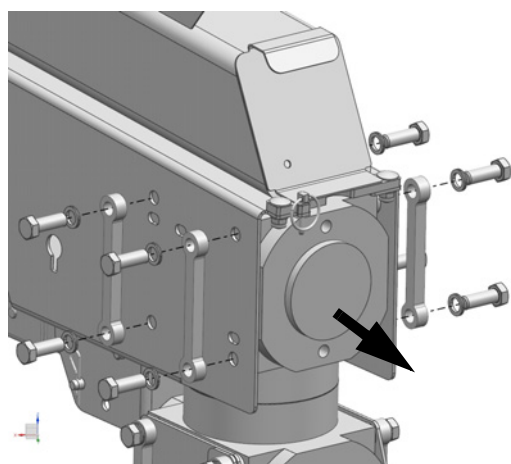
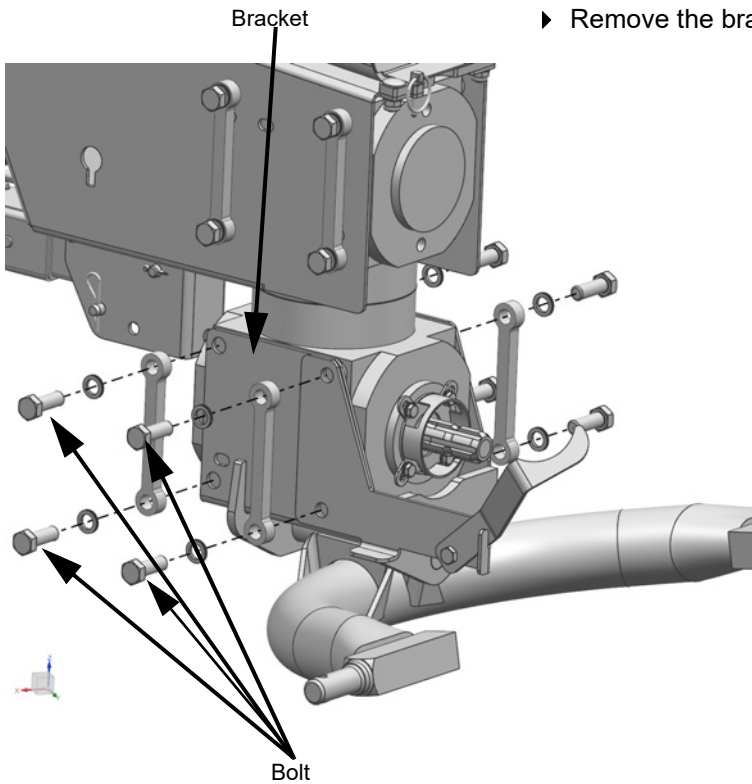

- ▶ Remove the bolts and Nord-Lock discs on both sides of the transmission.
- ▶ Remove the transmission.

Preparation

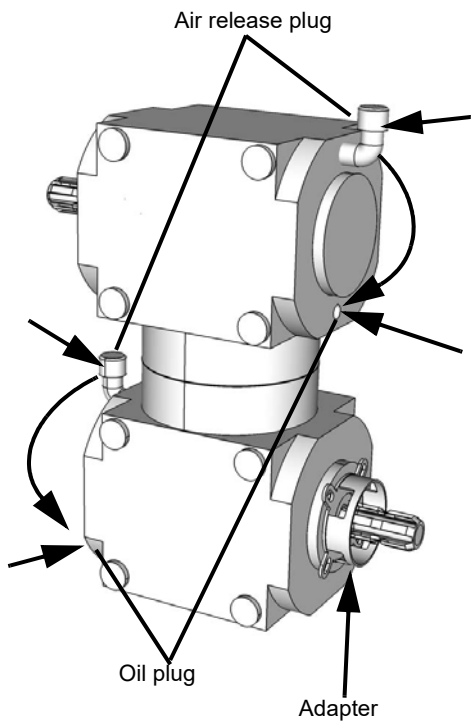

- ▶ Remove the air release plug and the oil plug and switch them over so that they exchange places.
- ▶ Remove the adapter for the P.T.O. shaft.

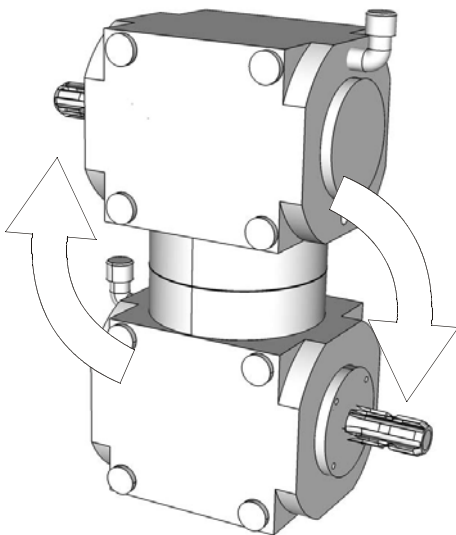

- ▶ Rotate the transmission 180 degrees.

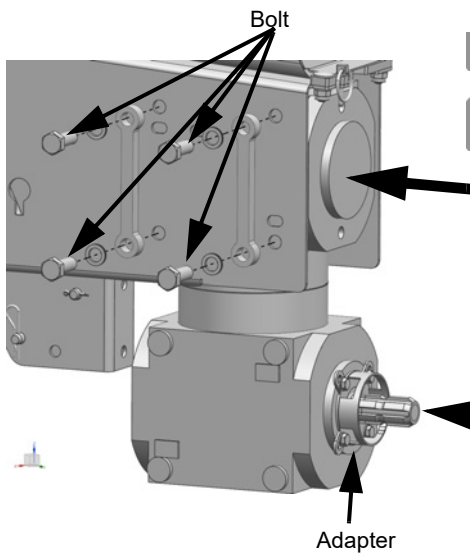

- ▶ Install the transmission.
- ▶ Remember the Nord-Lock washers.
- ▶ Affix the bolts on both sides of the transmission
- ▶ Tighten all bolts to the indicated torque.
- ▶ Install the adapter.

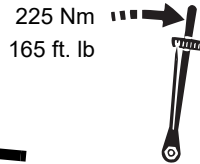

- ▶ Install the bracket.
- ▶ Remember the Nord-Lock washers.
- ▶ Affix the bolts on both sides of the transmission.
- ▶ Tighten all bolts to the indicated torque.
- ▶ Affix the P.T.O. shaft.

i Important!

- ▶ Check the oil level of both the upper and lower swivel gear.
- »Swivel gear« Page 114

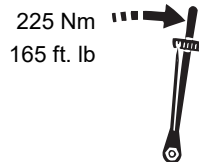
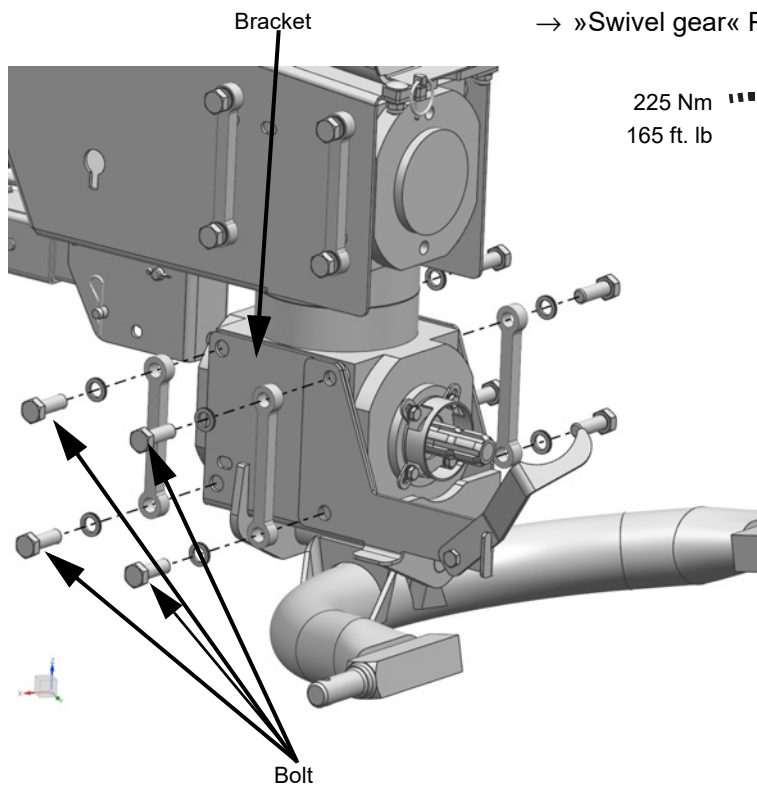

Preparation

Tool box

The machine is equipped with a tool box for storing common hand tools, extra blades etc.

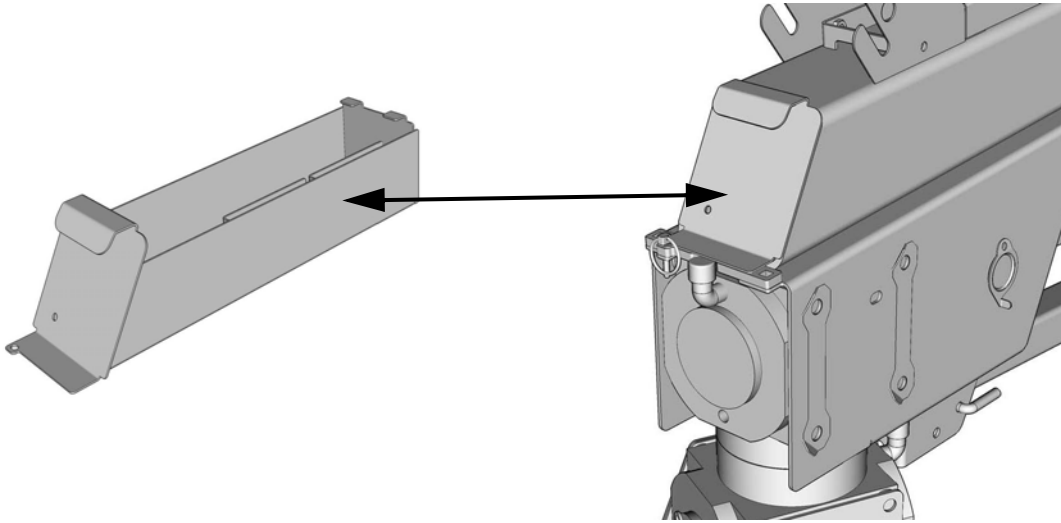

Attachment of the tractor



WARNING

Coupling a tractor and a machine together

When connecting the machine and the tractor there is an increased risk of personal injury. Attention to the task will ensure your safety and that of others. Failure to follow the safety instructions may result in serious injuries.

Therefore, when connecting the machine and the tractor you should:

- Make sure that the tractor cannot roll.
- Make sure that the tractor and the machine belong to the same category.
- Never stand between the tractor and the machine during attachment.
- Use the hydraulic three point suspension slowly and carefully.

Attachment of the machine

When connecting the machine on the tractor there is an increased risk of personal injuries. Attention to the task will ensure your safety and that of others. Failure to follow the safety instructions may result in serious injuries.

When carrying out an attachment you must make sure that:

- The machine is placed on an even surface.
- The machine is secured with a sturdy support.

Lock the tractor's lift arms

Lock the tractor's lift arms at the correct height. If the lift arms are at the correct height, it will prevent damage to the PTO shaft and injury to persons in the vicinity. Lowering or raising the lift arms can lead to injury and can damage the PTO shaft.

Secure the attachment with the locking pin

The attachment must be secured to the machine with the locking pin. The locking pin secures the machine against becoming detached from the tractor. Attachment without the locking pin can result in the machine becoming detached, leading to serious or fatal injury.

Therefore, when connecting the machine you should be sure that:

- The machine cannot become detached from the tractor.
- The coupling is secured with the locking pin.

Attachment

Attachment of the traction boom

- ▶ Check to see that the tire pressure on the tractor's rear wheel is correct.

→ »Check the tire pressure regularly« Page 26

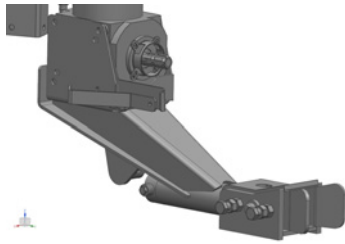

- ▶ Adjust the coupler on the machine to the tractor's traction boom as shown.

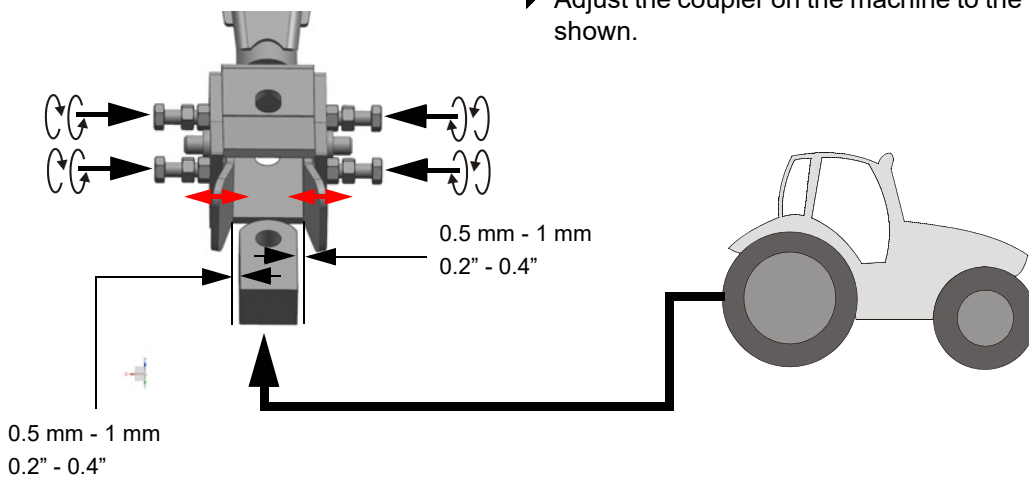

- ▶ Adjust the tractor's traction boom so that the P.T.O. shaft is as horizontal as possible when the machine is connected to the tractor.

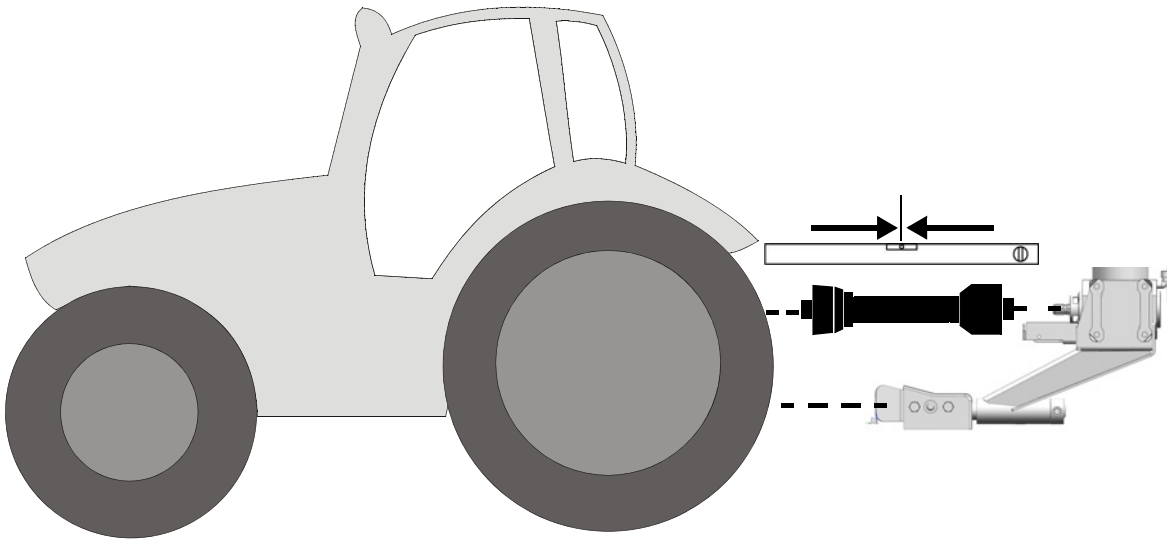

- ▶ Inspect and, if necessary, adjust the length of P.T.O. shaft.
 - »Length of P.T.O. shaft« Page 43
 - »Check the length of the P.T.O. shaft« Page 43
 - »Shorten the P.T.O. shaft« Page 44

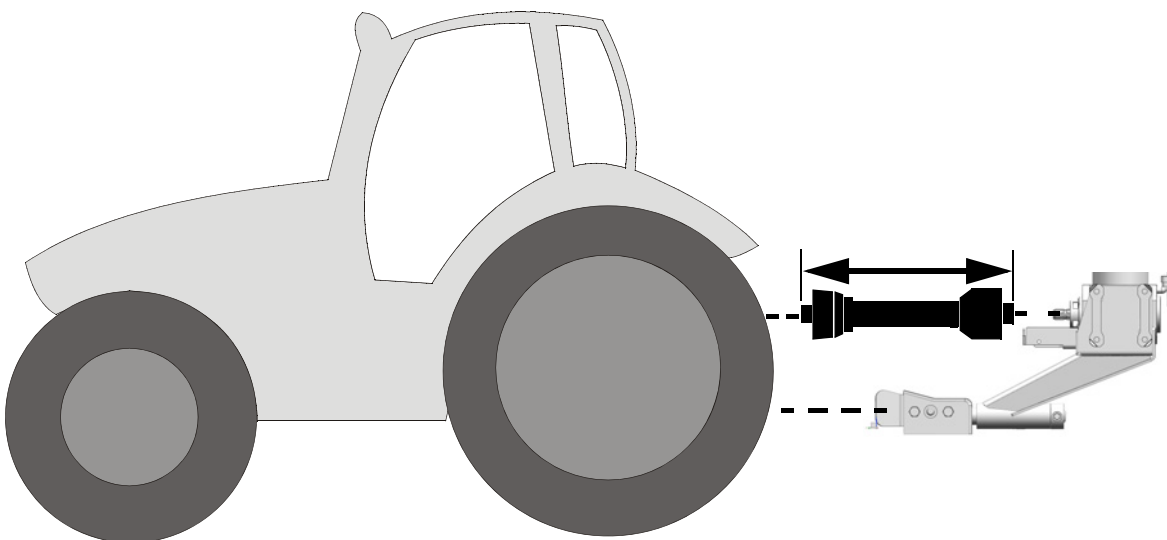

Attachment

Attachment of the lift arm

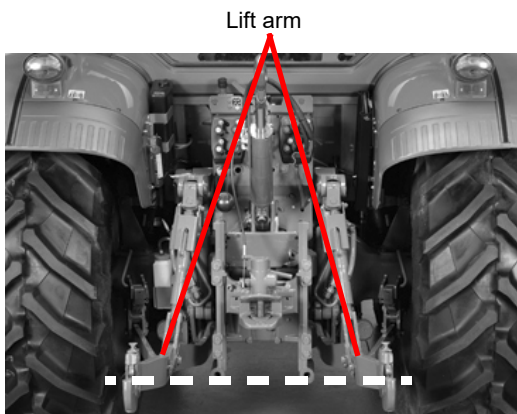
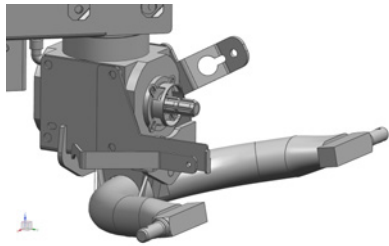

- ▶ Check to see that the tire pressure on the tractor's rear wheel is correct.
- »Check the tire pressure regularly« Page 26
- As a starting point:
 - ▶ Adjust the right and left lift arm so they are at the same height.

If a pivoting drawbar is mounted on the tractor:

- ▶ Swing the lower link crossbar to the side or remove the lower link crossbar.
- ▶ Raise or lower the tractor's lift arms until the machine's lifting pins can be attached to the tractor's lift arms.

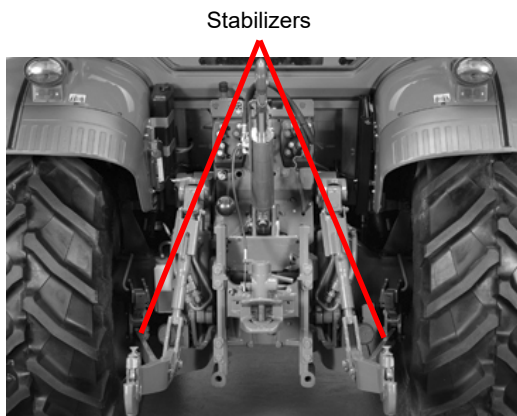

- ▶ Secure the attachment with the locking pin on both lift arms.
- ▶ Tighten the tractor' stabilizers.

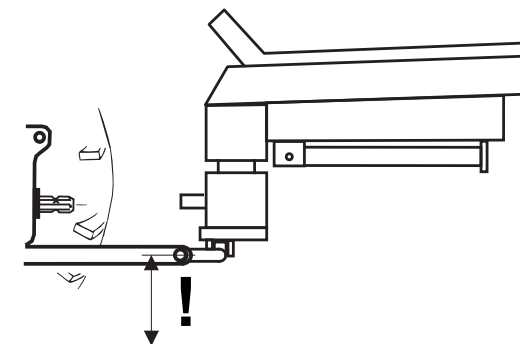

- ▶ Adjust the tractor's lift arms to the height shown:

Model	Dim.
8028 T/R	620 - 630 mm (24.5 - 24.8")
8032 / 8532 T/R	
8036 / 8536 T/R	
8540 T/R	740 - 750 mm (29 - 29.5")
8547 T/R	

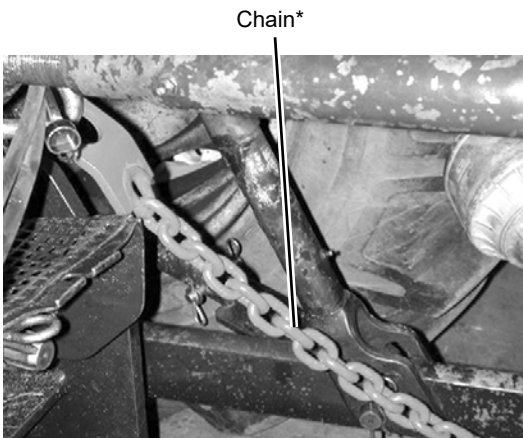

► Lock lift arms with a chain between the lifting arm and the highest point.

* Extra equipment.

→ »Extra equipment« Page 164

► Inspect and, if necessary, adjust the length of P.T.O. shaft.

→ »Length of P.T.O. shaft« Page 43

→ »Check the length of the P.T.O. shaft« Page 43

→ »Shorten the P.T.O. shaft« Page 44

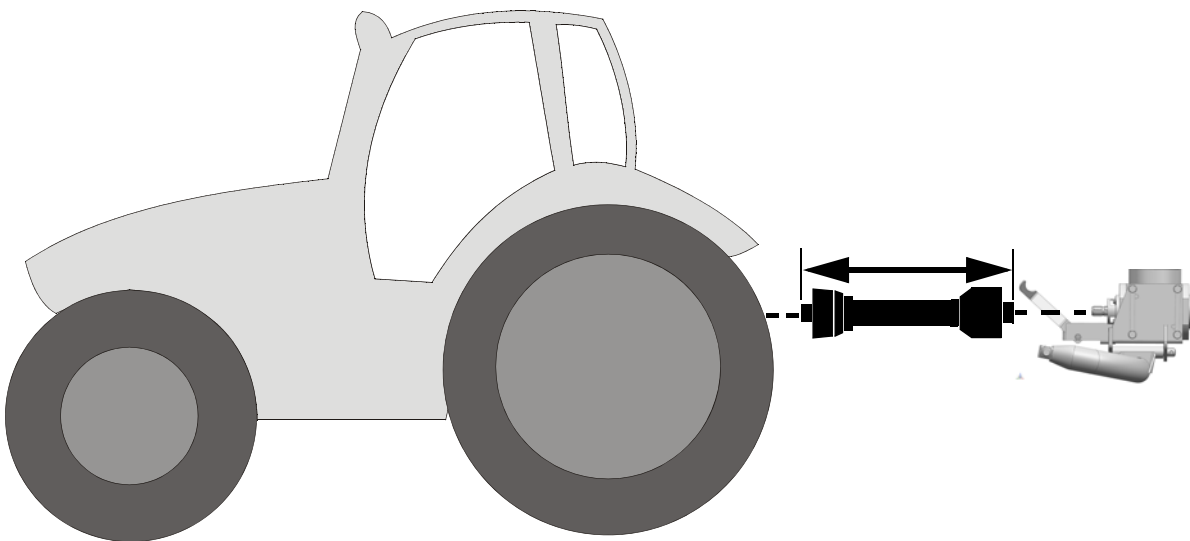

Safety chain

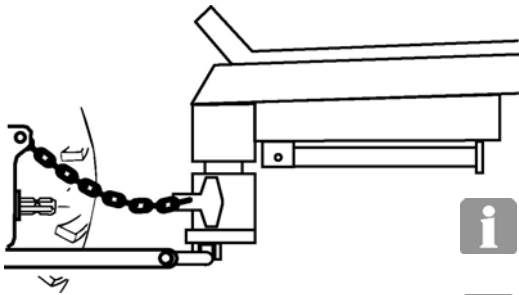



WARNING

Safety chain

When driving on public roads, the machine must always be secured with a safety chain between the tractor and the machine. Use a safety chain with a reinforcement suited to at least the total weight of the machine. If the machine should accidentally become detached, this could cause serious injury or death.

▶ Attach the safety chain between the tractor and the machine.

-  Choose an appropriate length of the chain so that it does not negatively affect the movement of the drawbar and hang too low.
-  Observe the national regulations concerning the length and the attachment of safety chains.

Lighting equipment



Check the electric cable

Check the electric cable. The insulation of the electric leads must not be unduly worn, and the cables must not be hanging loose. Electric cables with cable insulation that is missing or worn through must be replaced. Otherwise, this will damage the machine.

- ▶ Connect the accompanying cable to the tractor.
- ▶ Connect the plug for the 12 V power supply to the 7-pole plug socket on the tractor.



The machine is equipped with a light for road transportation. The lighting equipment is installed on the rear of the machine and is connected to the tractor using a 7-pole plug. The corresponding connection must be on the tractor (SAE J560).



If the tractor does not have the corresponding connection, this must be subsequently installed. Contact your dealer.



This lighting is controlled by the tractor. The lights are only lit if the tractor's parking lights are lit or the tractor's headlights are lit.

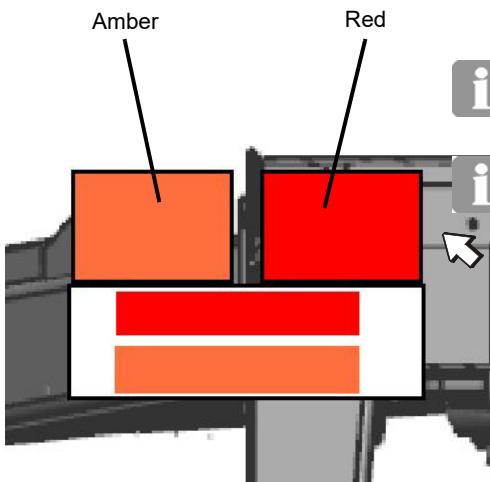

Attachment

SAE J560 plug - overview

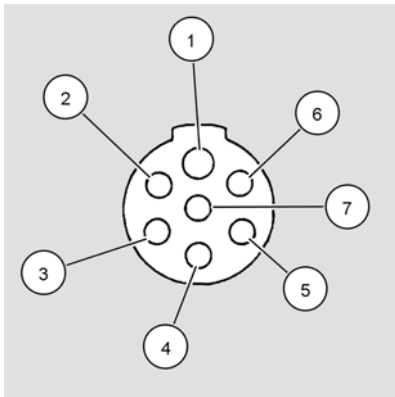

Pin	Cable	Connected to:
1	White	Ground, alt. light
2	Black	Not in use
3	Yellow	Left flasher (amber)
4	Red	Brake light
5	Green	Right flasher (amber)
6	Brown	Tail light (red)
7	Blue	Not in use

- ▶ Connect the plug for the 12 V power supply to the 7-pole plug socket on the tractor.

i Comply with the local regulations for lighting and marking for road use. Contact your dealer if the lighting does not work as specified.

Hydraulics

Safety



WARNING

Only connect the hydraulics when the system is depressurized

You should only connect the hydraulic hoses to the tractor's hydraulics when the hydraulic system on both the tractor and the machine is depressurized. There is a risk that the machine will move accidentally. Unintentional movement of the machine may result in serious injuries.

Avoid mixing oil

Avoid using different tractors for the same machine. It can lead to various oil types being improbable mixed. Improbable mixing of various oil types can damage the hydraulic system of the tractor.

The hydraulic system should be checked regularly

All hoses and fittings should be checked regularly for visible damage. Hydraulic hoses also wear without any visible damage. Defective hydraulic hoses can cause injury or fire.

Color markings of the hydraulic connections

The hydraulic connections between the tractor and the machine must be marked in different colors. By color marking the hydraulic connections, you avoid wrong operation of the machine. Incorrect operation or unintentional movement of the machine may result in serious injuries.

Connecting hydraulics

When connecting the hydraulics there is an increased risk of personal injuries. Paying full attention to the aforementioned point ensures your safety and that of others. Failure to follow the above instructions may result in serious injuries.

Securing the hydraulics in transport position

The tractor hydraulic system must not be activated unintentionally in transport position. Accidental activation of the tractor hydraulic system can result in unexpected movement. Unexpected movement can result in injuries.

Attachment

Hydraulic connection

WARNING

Checking that the hydraulic system is correctly connected
Ensure that the hydraulic system is correctly connected. Otherwise, this can cause injuries, and damage to the machine.



- ▶ Stop the tractor and remove the ignition key.

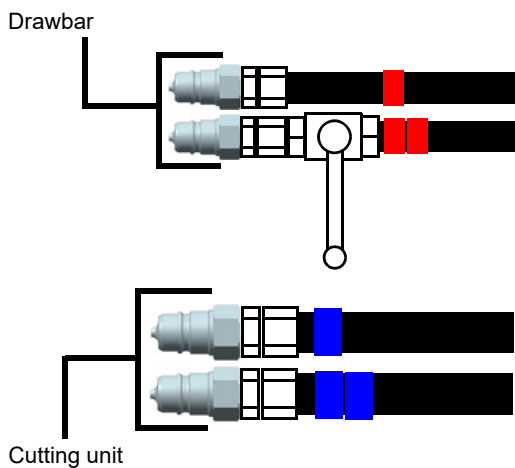

The tractor must be fitted with 2 sets of double acting hydraulic outlets, which are connected as follows:

Hydraulic hose for:	Color marking	Function
Drawbar	Red	right
	Red	left
Cutting unit	Blue	up
	Blue	down

When connecting the hydraulic hoses you should check that:

- The hydraulic hoses are connected in pairs to the tractor's hydraulic pressure and return outlet on the tractor.

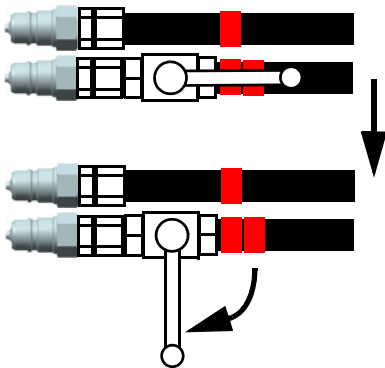

When driving on public roads, the mechanical safety valve must always be closed.

→ »Transport on public roads« Page 101

→ »Transport position« Page 63

Initial start

WARNING

The initial test drive of the machine is important

When the machine is connected to the tractor for the first time it must be test driven. Attention to the task will ensure your safety and that of others. Failure to follow the safety instructions may result in serious injuries.

Do not remove the protective guards

Check that all protective guards are in place before use. This ensures that the machine will offer maximum protection to the operator from the cutting blades. If the safety guards are removed or not used, it may result in serious injuries and accidents.

The guard for the cutting unit must be correctly positioned before start up

The guard for the cutting unit must be folded down and correctly positioned before the machine is started. This ensures that the machine will give maximum protection to the operator from thrown objects. Thrown objects may cause serious injuries and accidents.

- ▶ Check that the machine's guards are in place.
- ▶ Check that the side guard on the cutting unit is folded out and correctly positioned.

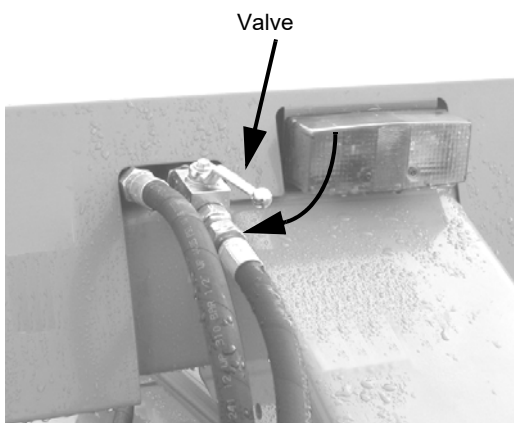
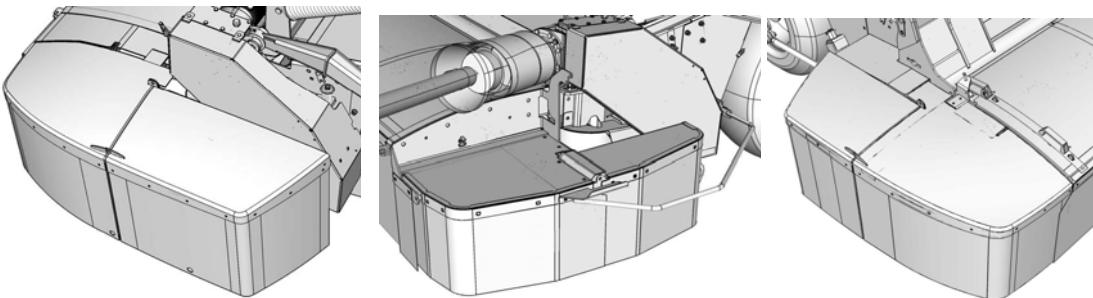

- ▶ Check that the mechanical safety valve is open.
- ▶ Carefully connect the tractor's P.T.O. shaft.
- ▶ Carefully increase the speed on the P.T.O. shaft to 540/1000 RPM.
→ »Number of revolutions on the P.T.O. outlet« Page 46
- ▶ Check that the machine runs smoothly without any vibrations.
- ▶ Reduce the P.T.O. shaft to idle speed.
- ▶ Activate all the hydraulic functions of the machine, one by one.
- ▶ Disconnect the tractor's P.T.O. shaft.

Attachment

Checking the cutting unit

Equalizing the hydraulic system

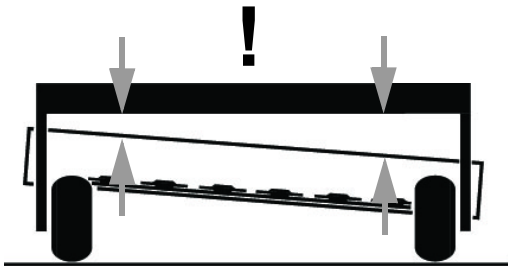

After a prolonged period without use with the cutting unit raised, there is a risk that the machine's cutting unit may sink unevenly in the machine's hydraulic cylinder. This means that the cutting unit is not parallel with the machine's main frame. The problem can be solved by equalizing the machine's hydraulic system, which is carried out as follows:



- ▶ Activate the tractor's hydraulics and lower the machine's cutting unit down to the ground.
- ▶ Continue to run the tractor's hydraulic system for approx. 2-5 minutes.

i This ensures the machine's hydraulic cylinders are emptied of any air and excess hydraulic oil.

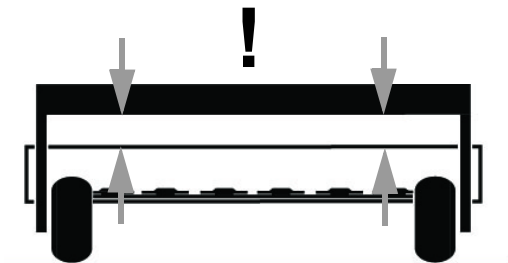

- ▶ Raise the machine's cutting unit and check that the cutting unit is parallel with the main frame of the machine.
- ▶ Repeat the procedure if the cutting unit is not parallel with the main frame of the machine.

Transport position

WARNING

Check and clear the surrounding area before starting to use machine

Before driving and using the machine the surrounding area should be checked and cleared. This prevents persons and animals in the vicinity from being harmed. If the surrounding area is not checked, it may result in serious injuries to persons or animals.

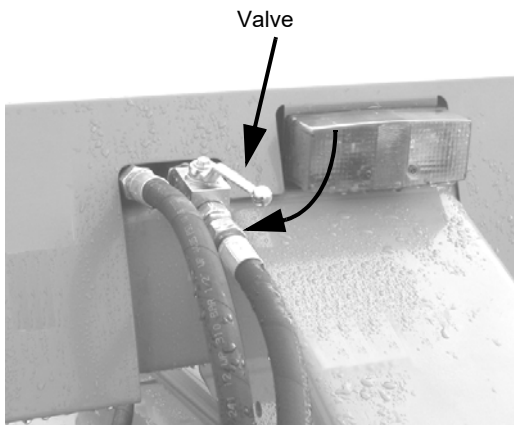

The machine is placed in its transport position in the following way:

- ▶ Check that the mechanical safety valve is open.

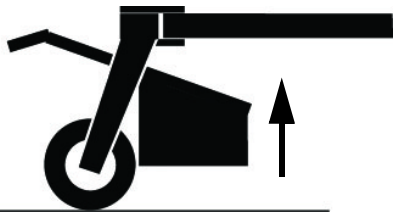

- ▶ Activate the tractor hydraulics and raise the machine's cutting unit.

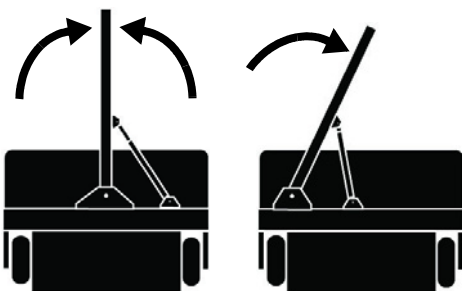

- ▶ Activate the tractor's hydraulics and set the machine's drawbar as shown.

Attachment

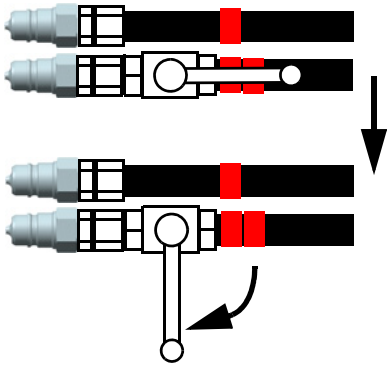

- ▶ Close the mechanical safety valve for the drawbar.
→ »Transport on public roads« Page 101

Guard

Right-hand side 85xxT-R model

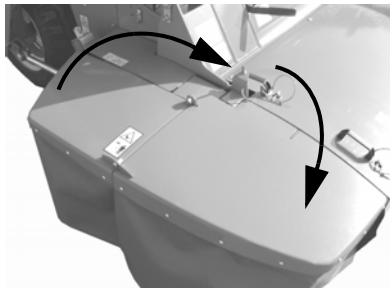

- ▶ Swivel the protection around as shown.

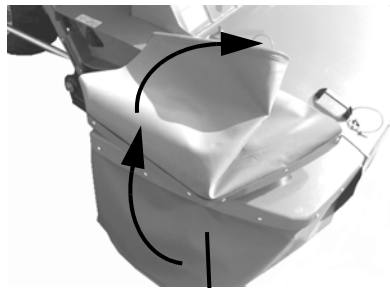

- ▶ Tilt the whole guard up as shown.
- ▶ Fit the linchpin as shown.

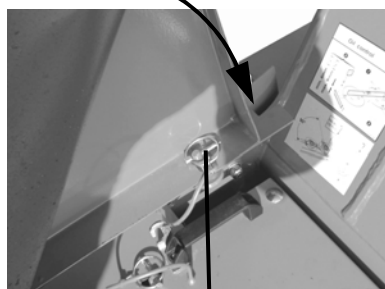
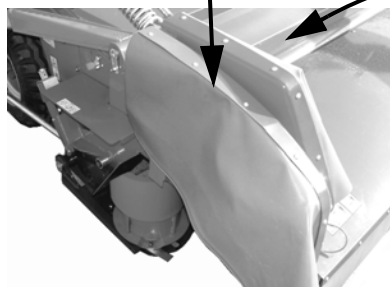

Linchpin

Left-hand side 80xxT-R model

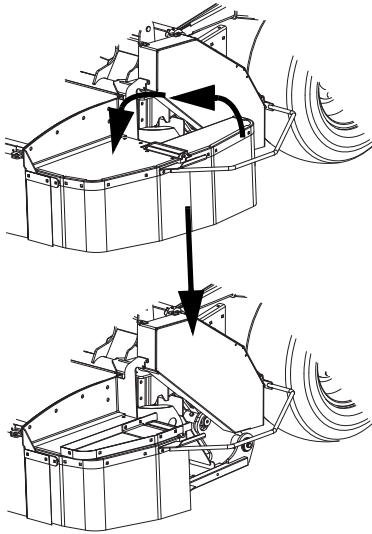

- ▶ Swivel the protection around as shown.

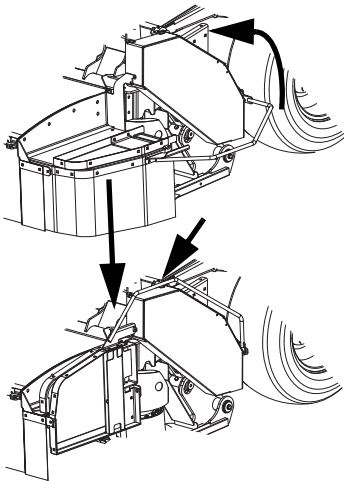

- ▶ Take hold of the bar and lift the guard up as shown.
- ▶ Secure the guard with the lynchpin.



If the side guard is in the transport mode, the machine must not be started.

Attachment

85xxT-R model

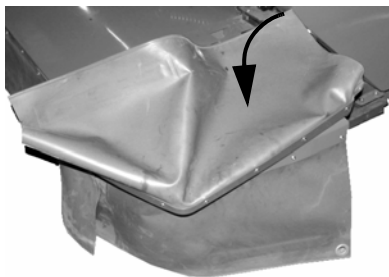

- ▶ Swivel the protection around as shown.

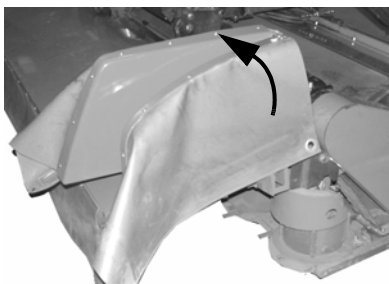

- ▶ Tilt the whole guard up as shown.

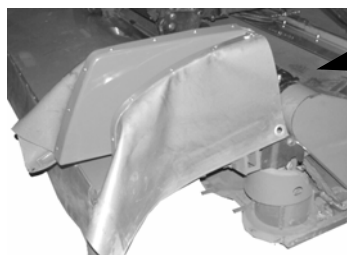

- ▶ Fit the lynchpin as shown.



If the side guard is in the transport mode, the machine must not be started.

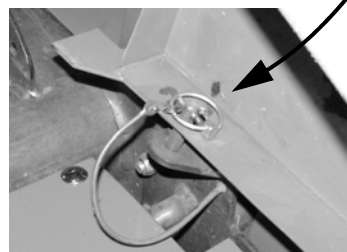

Safety



WARNING

The operator should receive careful instructions before using the machine

The machine should only be used if the operator has been given thorough instructions. Thorough machine instruction allows safe usage. Insufficient training may lead to incorrect usage of the machine and accidents.

Read the safety instructions before using the machine

Before using the machine, the operator should read the safety instructions carefully.

→ »Safety« Page 9

Attention to the task will ensure your safety and that of others. Failure to follow the instructions may result in serious injuries.

The guard for the cutting unit must be correctly positioned before start up

The guard for the cutting unit must be folded down and correctly positioned before the machine is started. This ensures that the machine will give maximum protection to the operator from thrown objects. Thrown objects may cause serious injuries and accidents.

Do not remove the protective guards

Check that all protective guards are in place before use. This ensures that the machine will offer maximum protection to the operator from the cutting blades. If the safety guards are removed or not used, it may result in serious injuries and accidents.

Before operating



WARNING

The following instructions should be complied with:

- Check all points mentioned in the “maintenance” section.
→ »Specific safety information« Page 109
→ »Lubrication safety and use of oil« Page 110
- Check blades are not worn down. The blades can be turned so as to gain the opposite rotational direction.
→ »Blades« Page 117

Operation

Working position

The machine is operated in the following way:

- ▶ Make sure that there are no persons in the surrounding area.
- ▶ Fasten all the guards on the machine.
- ▶ Check that the side guard on the cutting unit is folded out and correctly positioned.
- ▶ Position the tractor and the machine in a straight line.

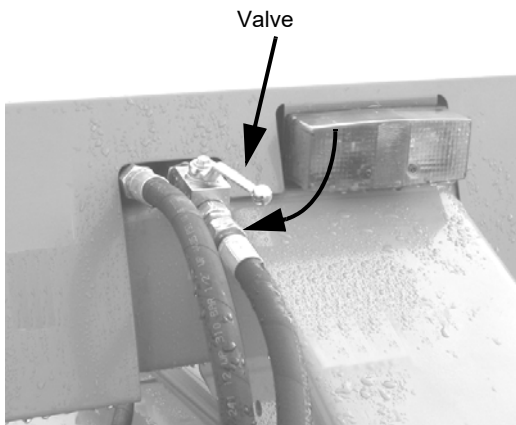
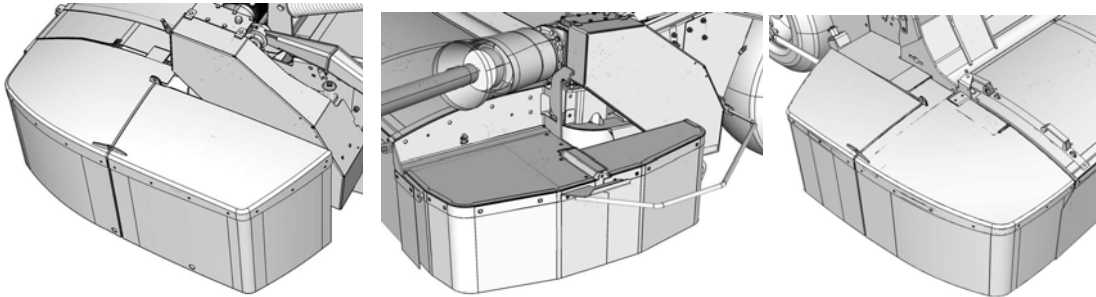

- ▶ Check that the mechanical safety valve is open.

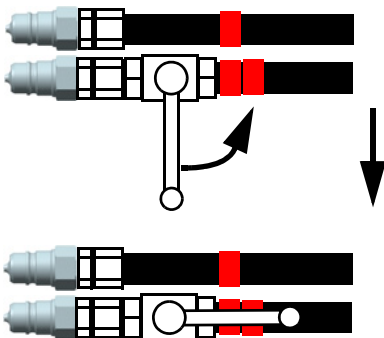

- ▶ Check that the mechanical safety valve for the drawbar is open.
- ▶ Carefully connect the tractor's P.T.O. shaft.
- ▶ Carefully increase the speed of the P.T.O. shaft to 540/1000 rpm.
→ »Number of revolutions on the P.T.O. outlet« Page 46
- ▶ Use the tractor's machine handle to operate the hydraulic functions.



If none of the machine's functions are working:

- ▶ Stop the tractor's forward motion.
- ▶ Stop the tractor.
- ▶ Disconnect the tractor's P.T.O. shaft.



If the machine is too noisy or vibrates too much, stop the machine immediately.

→ »Troubleshooting« Page 171.

Conditioner

Only T model

Basic setting of the conditioner plate

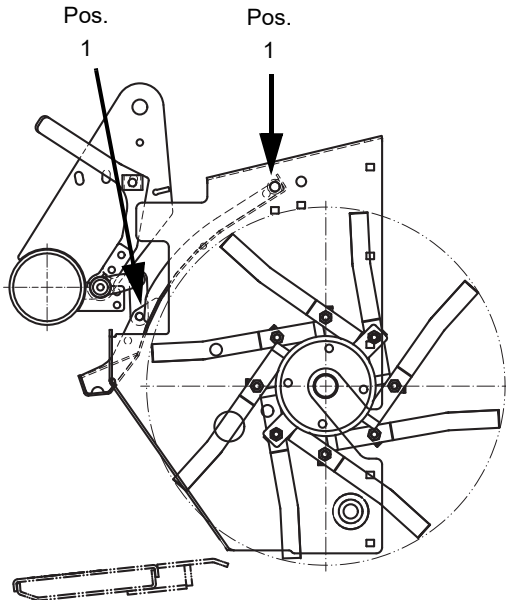

The conditioner plate has two basic settings:

Pos. 1:

This setting is recommended for light crops, e.g. from normal, clean grass crops to grass crops with moderate amounts of leaves. In this position, the intake is made with the first part of the conditioner plate and the rotor slightly open and gives optimal conditioning of light crops.

This setting should be used for light crops, e.g. from clean grass crops to grass crops with moderate amounts of leaves.

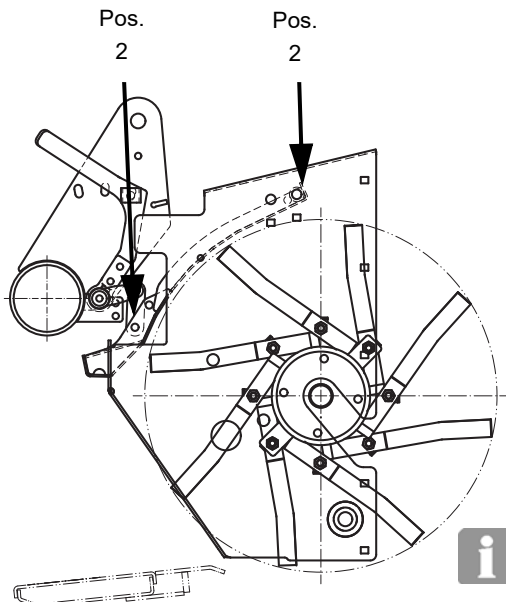

Pos. 2:

This setting is recommended if problems occur relating to the blocking of the rotor and the flow of heavy crops through the machine. In this position, the intake is made with the first part of the conditioner plate and the rotor more open and gives better and smoother passage of heavy crop through the machine.

This setting should be used for heavy crops, e.g. from grass crops with moderate amounts of leaves to lush and leafy spring crops.



The conditioner plate is factory-fitted in position 2.

To move the conditioner plate to pos. 1, carry out the following steps:

- ▶ Activate the tractor hydraulics and raise the machine's cutterbar fully.



Operation

- ▶ Close the mechanical safety valve.

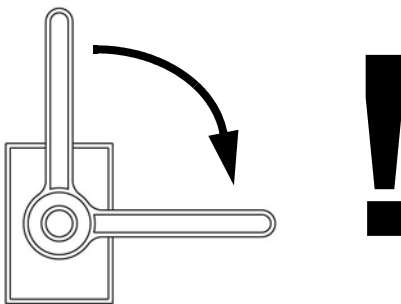
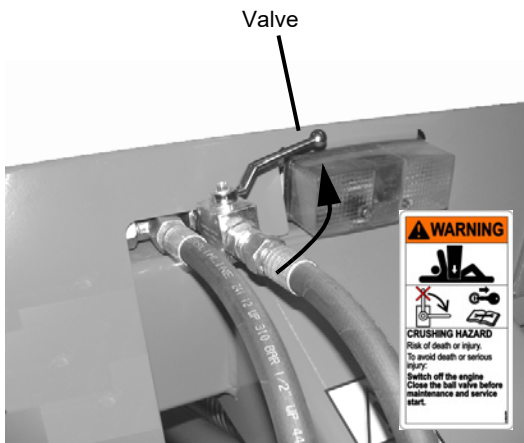

- ▶ Remove the pin bolts on both sides of the machine.

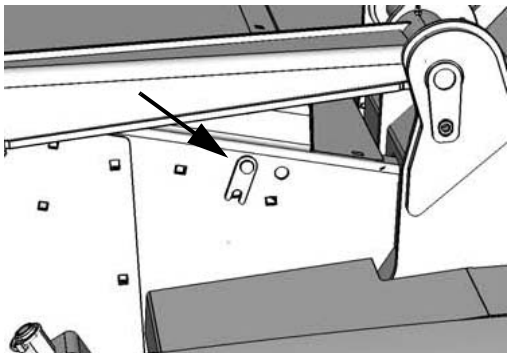
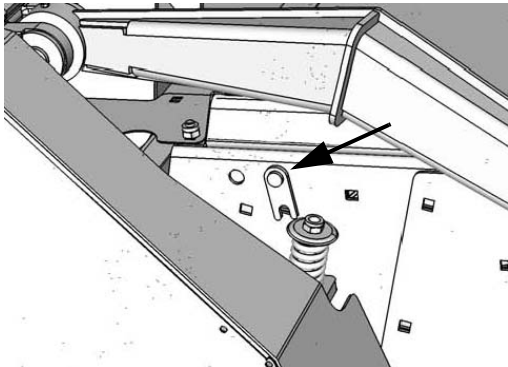

- ▶ Allow the conditioner plate to drop down onto the rotor so there is access between the conditioner plate and the upper plate on the machine.

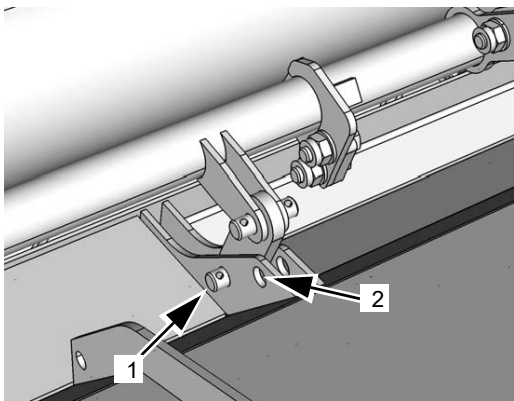
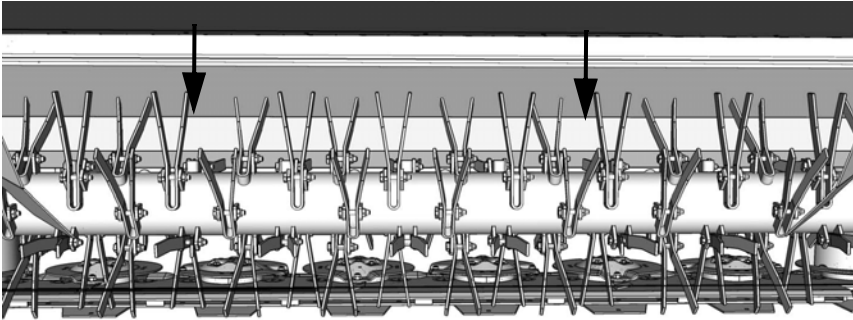

- ▶ Remove the pin bolt shown on both sides of the conditioner plate.
- ▶ Move the linkage back on the conditioner plate [1→2] as shown and fit the pin bolt to both sides of the conditioner plate.

- ▶ Lift the conditioner plate up from the rotor.

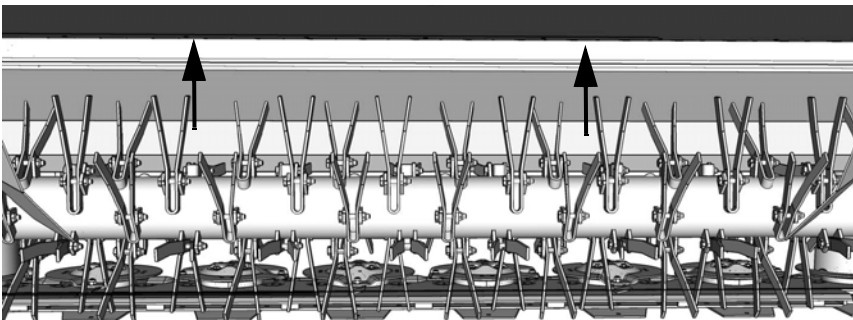

Operation

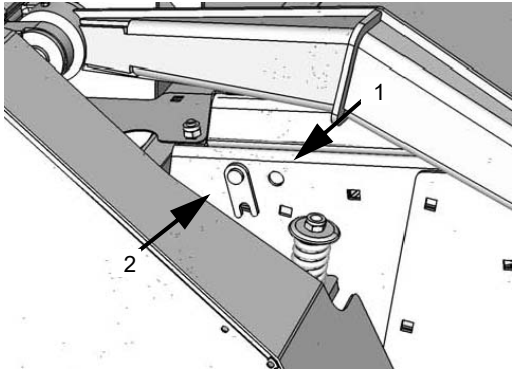

- ▶ Move the pin bolts to the front position [1→2].
- ▶ Fit the conditioner plate on both sides of the machine.

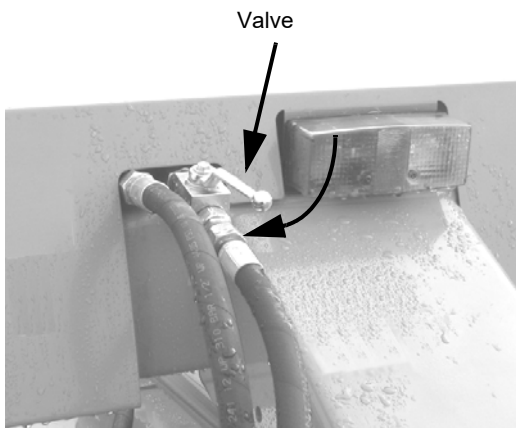
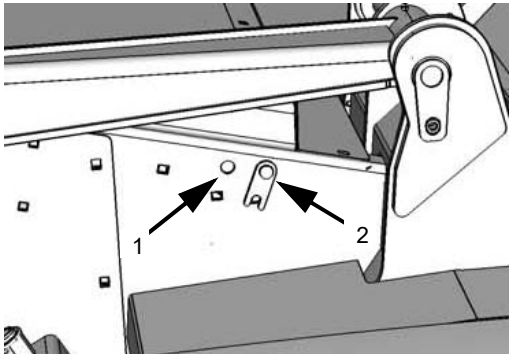

- ▶ Open the mechanical safety valve.

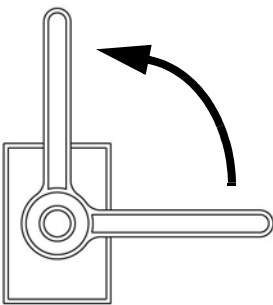

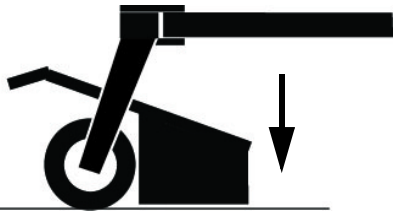

- ▶ Activate the tractor hydraulics and lower the cutting unit of the machine.

Fine adjustment of the conditioner plate

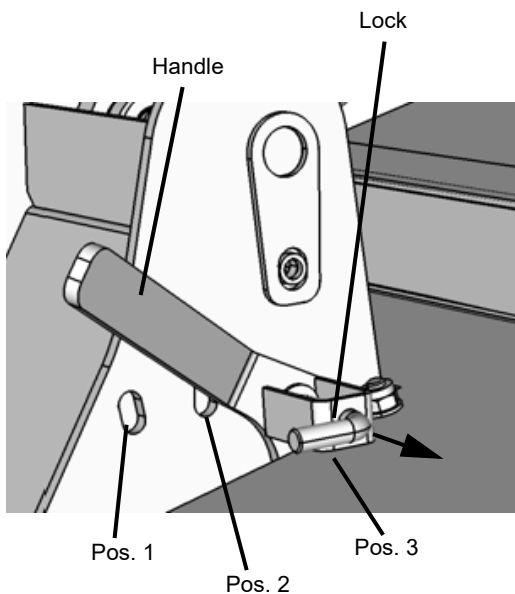

The conditioner plate can also be adjusted to 3 positions with a handle, regardless of its basic setting.
→ »Basic setting of the conditioner plate« Page 69

The conditioner plate is fine-tuned in the following way:

- Pull out the lock.
- Move the handle to the desired position.
- Release the lock.
- Check that the handle is locked in the desired position.

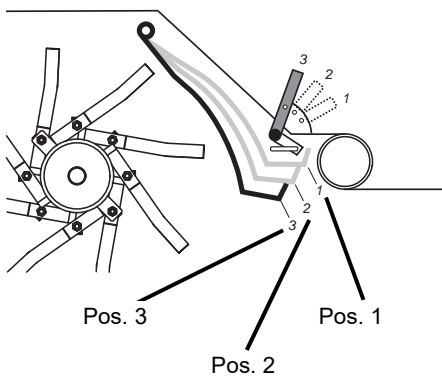

The fine tuning can be adjusted to suit the crop using the following settings:

	Pos. 1	Pos. 2	Pos. 3
Conditioning of crop	Light	Moderate	Heavy
Crop throwing distance	Short	Moderate	Long



The diagram is only given as a guide



The rotor's RPM also has an influence on the condition of the crop, the conditioning, and the crop throwing distance.

→ »RPM of rotor« Page 167

Operation

Rotor

900 RPM is the standard rotation speed of the rollers.
 The rotor can be set to the indicated RPM.
 The recommended RPM for the rotor should be as follows:

Type of crop	Rotor RPM	Diameter Pulley on the transmission	Diameter Pulley on the rotor
Normal, clean grass crops and crops with moderate amounts of leaves	900	φ225 mm (9")	φ190 mm (7.5")
Lush and leafy spring crops as well as alfalfa and clover	600	φ190 mm (7.5")	φ225 mm (9")
Difficult crops and/or installed Bx-equipment*	1015*	φ225 mm (9")	φ161 mm* (6.5"*)
Whole seed*	500*	φ161 mm* (6.5"*)	φ225 mm (9")
Heavy-Duty set*	900*	φ280 mm* (11"*)	φ225 mm (9")

* Extra equipment.
 → »Extra equipment« Page 164

To ensure the correct conditioning and length of the crop, it is recommended you check the conditioner plate's setting.
 → »Basic setting of the conditioner plate« Page 69
 → »Fine adjustment of the conditioner plate« Page 73

The RPM for the rotor can be changed as follows:

- ▶ Activate the tractor hydraulics and lower the cutting unit of the machine.



- ▶ Remove the guard around the transmission.

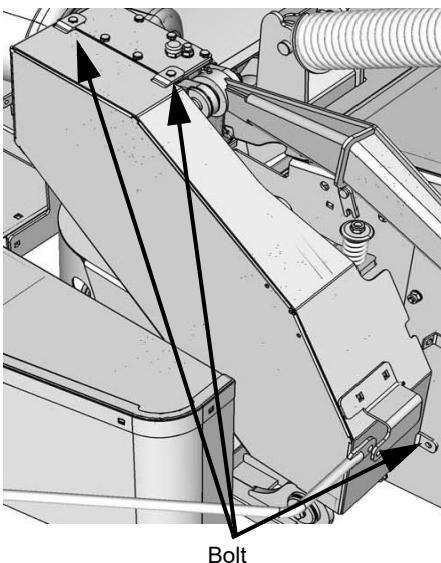

- ▶ Completely loosen the bolt on the spring.
- ▶ Remove the V-belts.

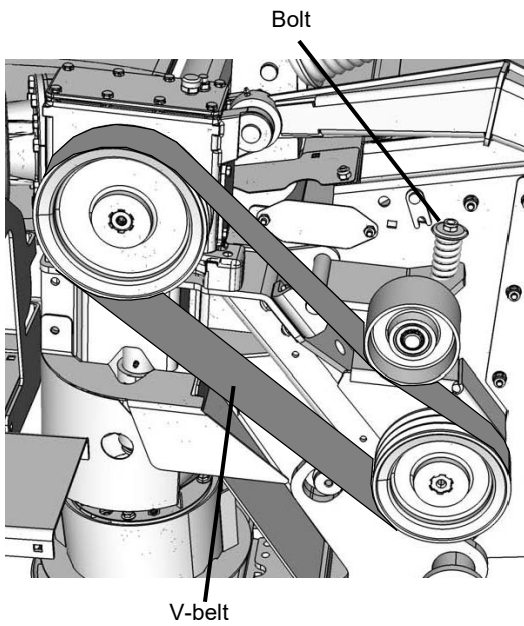

- ▶ Remove the bolt for the pulley.

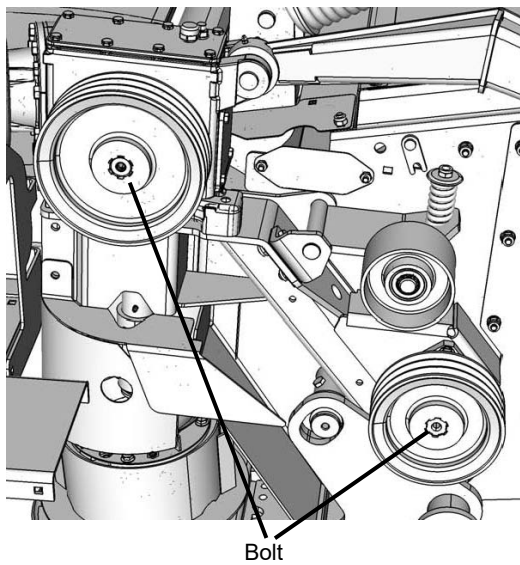

- ▶ Swap the pulleys.

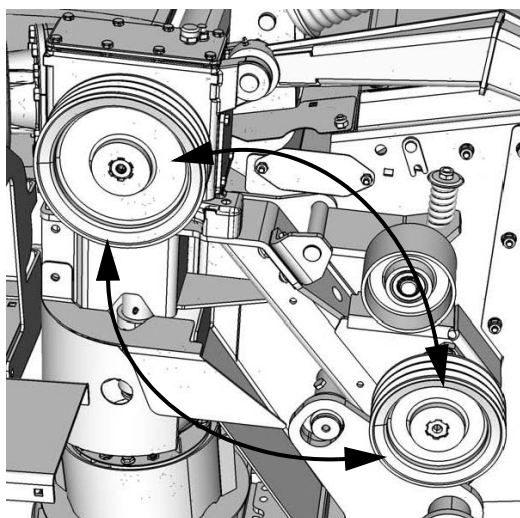

Operation

- ▶ Fit the V-belts.
- ▶ Tighten the springs to the measurement shown.

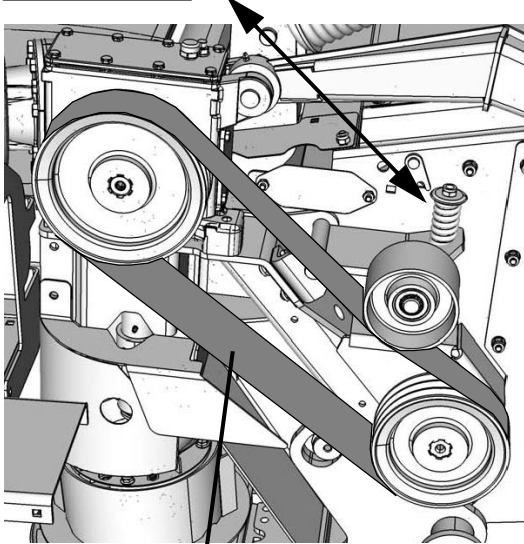
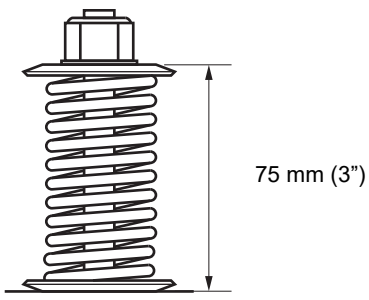

V-belt

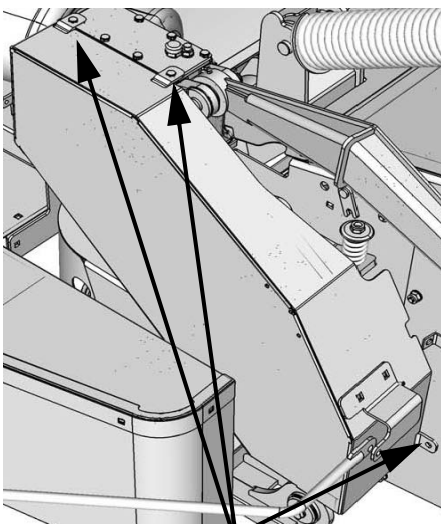

- ▶ Affix the protection.

Bolt

Rollers

Only R model

1000 RPM is the standard rotation speed of the rollers.

As an option, the machine can be equipped with a pulley so that the rotation of the rollers is 1200 RPM

Type of crop	Rollers RPM	Diameter Pulley on the transmission
Normal grass crops, as well as alfalfa without the use of Bx-equipment	1000	φ225 mm (9")
Lush and leafy spring crops as well as alfalfa and clover	750*	φ161 mm* (6.5"*)
Normal grass crops, as well as alfalfa with the use of Bx-equipment	1200*	φ280 mm* (11"*)

* Extra equipment.

→ »Extra equipment« Page 164



The recommended rotation with the use of Bx-equipment is 1200 RPM.

Shift to 750 RPM or 1200 RPM

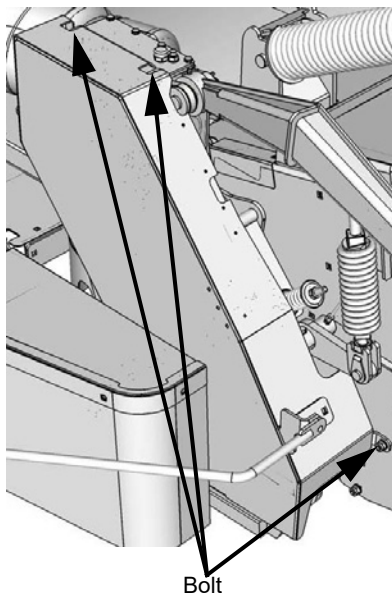

Available only as an option

The RPM for the rotor can be changed as follows:

- ▶ Remove the protection around the transmission.

Operation

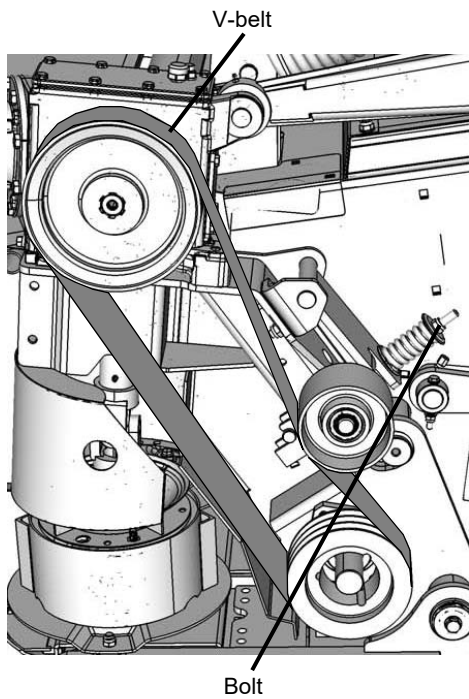

- ▶ Completely loosen the bolts on the spring.
- ▶ Remove the V-belts.

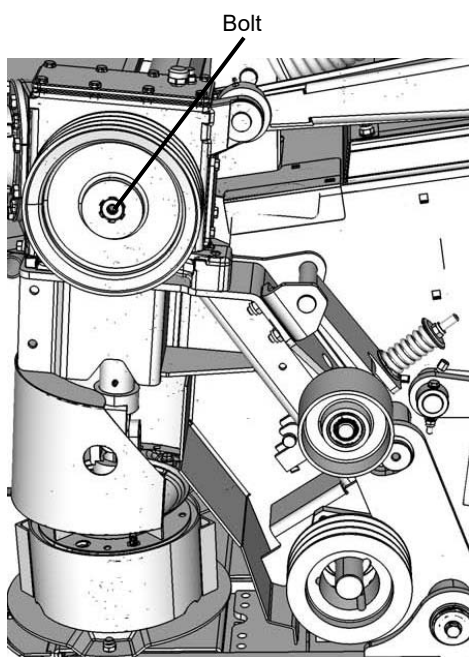

- ▶ Remove the bolt for the pulley.

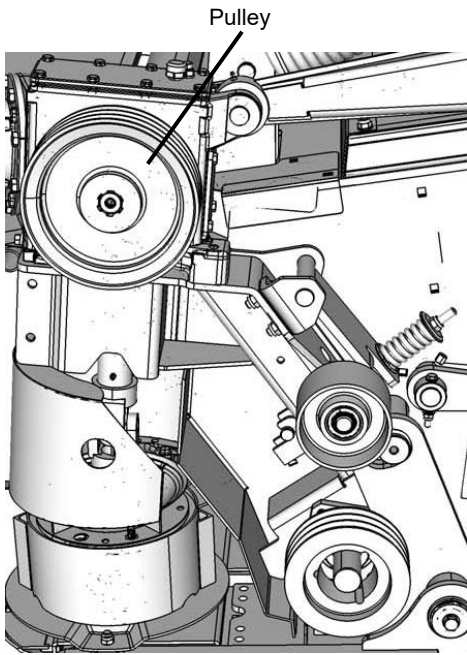

- ▶ Dismantle the pulley.
- ▶ Install the new pulley.

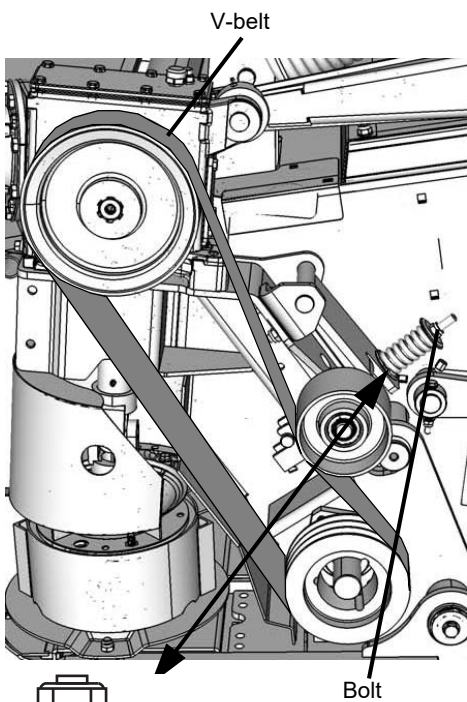

- ▶ Install the V-belt.
- ▶ Tighten the springs to the measurement shown.
- ▶ Attach the protection.

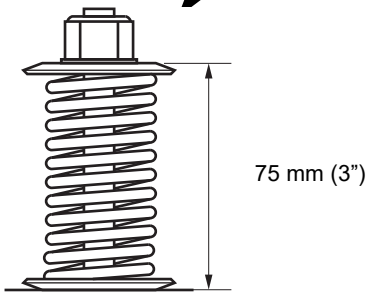

Operation

Roller pressure

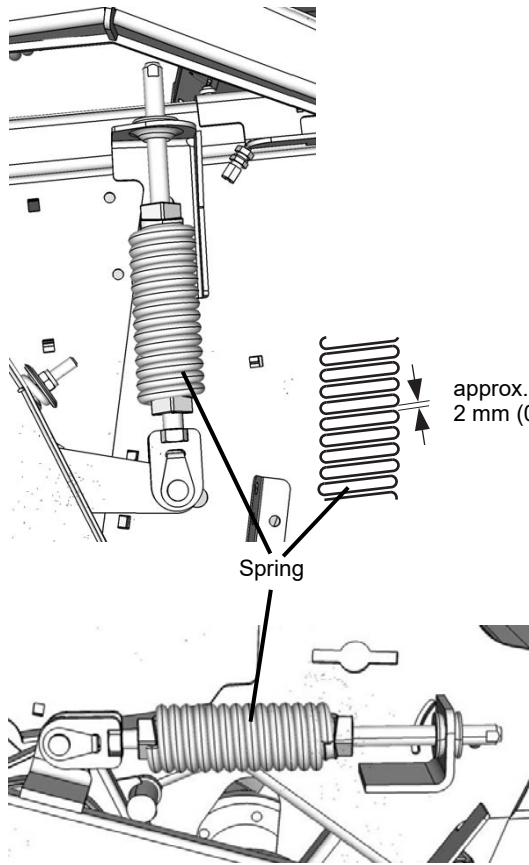

The rollers' pressure against the crop is dependent on the nature and quality of the crop.

- At harvest, the pressure of the rollers should be increased for grassy crops.
- At harvest, the pressure of the rollers should be decreased for clover and other leafy crops.

The pressure of the rollers against the crops is adjusted by means of powerful springs on both sides of the machine.

The springs have a standard factory setting of approximately 2 mm (0.08 ") between the spring's windings as shown.

Changing the roller pressure

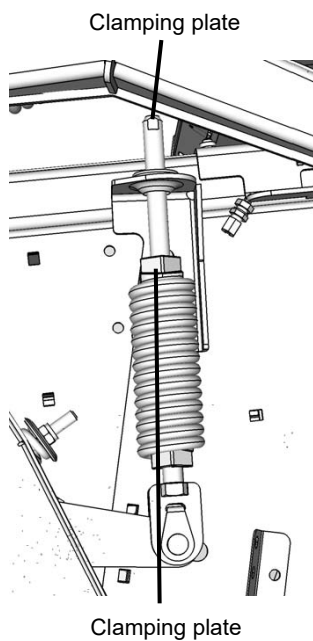
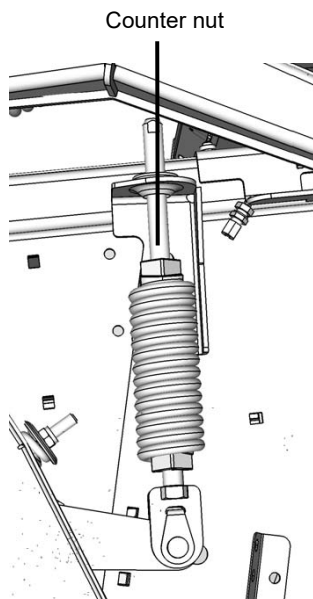

i The springs on both sides of the machine must be set the same.

The roller pressure is adjusted as follows:

Left-hand side

- ▶ Use the appropriate tool and remove the shown counter nut located near the spring.

- ▶ Place a tool in the spring's clamping plate.
- ▶ Place a tool in the spring's clamping plate.
- ▶ Use the tool on the spindle and tighten the spindle.



- Turning the spindle clockwise increases the pressure of the rollers on the crop.
- Turning the spindle counterclockwise decreases the pressure of the rollers on the crop.



We recommend that you adjust the springs approximately 5 mm (0.2") at a time, after which the roller pressure against the crop is checked.

Operation

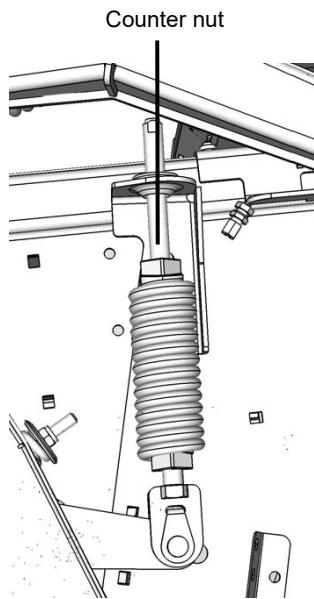

- ▶ Tighten and secure the lock nut on the spring after adjustment.



The springs on both sides of the machine must be set the same.

The roller pressure is adjusted as follows:

Right-hand side

- ▶ Use the appropriate tool and remove the shown counter nut located near the spring.

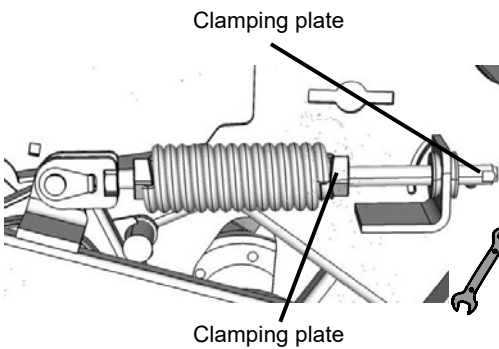
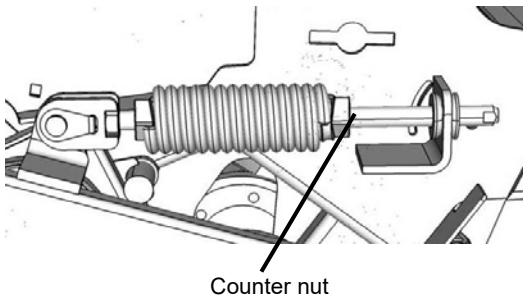

- ▶ Place a tool in the spring's clamping plate.
- ▶ Place a tool in the spring's clamping plate.
- ▶ Use the tool on the spindle and tighten the spindle.
- Turning the spindle clockwise increases the pressure of the rollers on the crop.
- Turning the spindle counterclockwise decreases the pressure of the rollers on the crop.



We recommend that you adjust the springs approximately 5 mm (0.2") at a time, after which the roller pressure against the crop is checked.

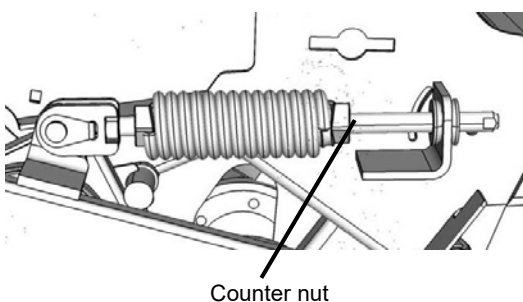

- ▶ Tighten and secure the lock nut on the spring after adjustment.

Distance between rollers

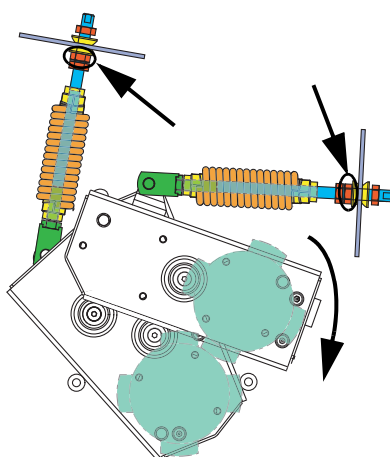
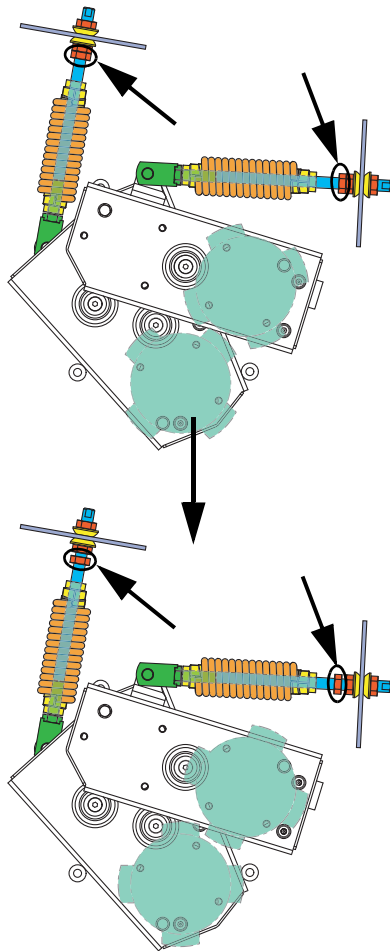

Reduction of distance between rollers

The distance between the rollers is reduced as follows:

- ▶ Remove the counter nut as shown.

- ▶ Reduce the distance between rollers by turning the nuts as shown.

Operation

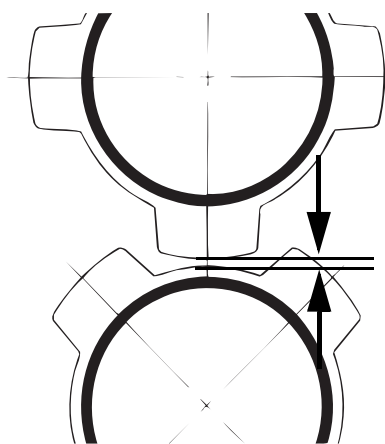

➡ The recommended distance between the rollers must be 5 mm (0.2").

5 mm (0.2")



The distance between rollers is checked as follows:
It is recommended that two people do the check.

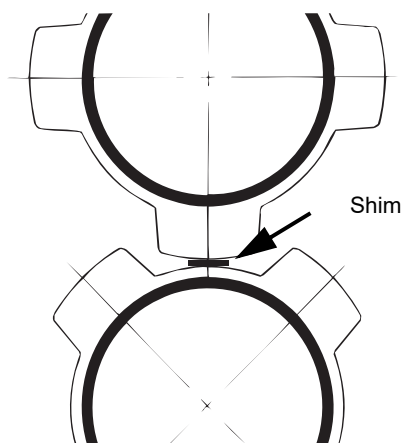

- ▶ Place a shim measuring 5 mm (0.2") between the rollers approximately 50 mm (2") from the outermost end on both the right and left side.
- ▶ Turn the rollers slightly so that the shims are located between them.
- ▶ Check to make sure that the rollers are just barely squeezing on the shims.

- If the distance between the rollers is too great:
→ »Reduction of distance between rollers« Page 83

- If the distance between the rollers is too little:
→ »Reduction of distance between rollers« Page 85

- ▶ Tighten the counter nut.

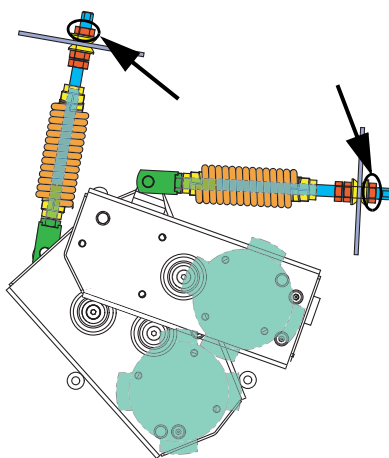

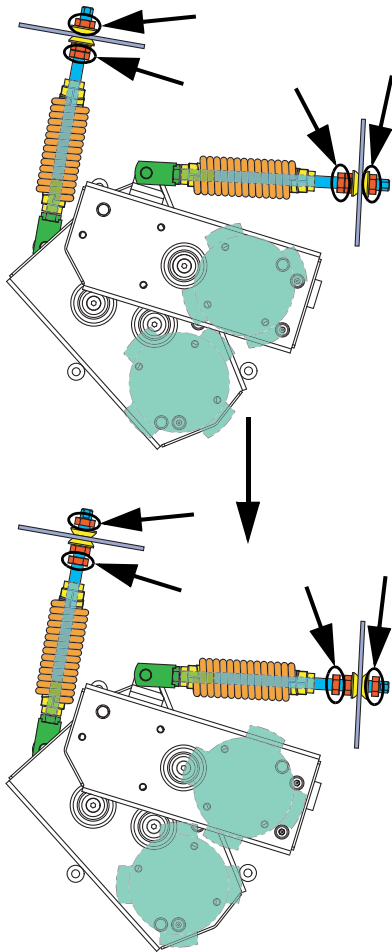

Reduction of distance between rollers

The distance between the rollers is increased as follows:

- ▶ Remove the counter nut as shown.

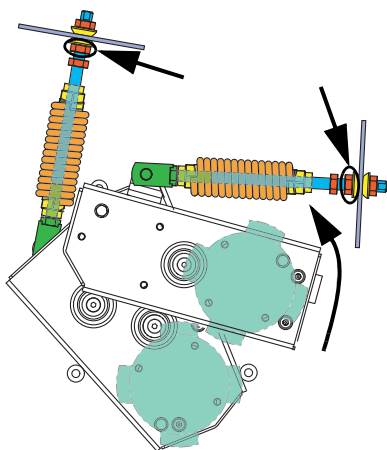

- ▶ Increase the distance between rollers by turning the nuts as shown.

Operation

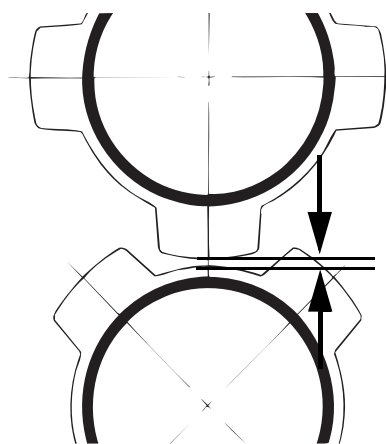

➔ The recommended distance between the rollers must be 5 mm (0.2").

5 mm (0.2")



The distance between rollers is checked as follows:
It is recommended that two people do the check.

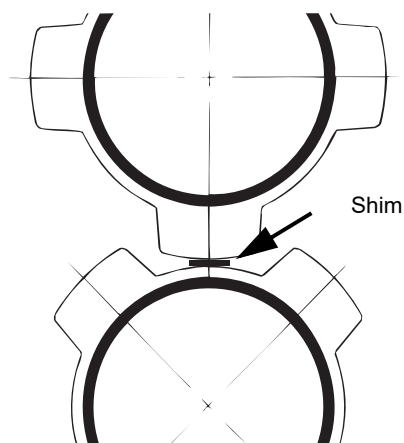

- ▶ Place a shim measuring 5 mm (0.2") between the rollers approximately 50 mm (2") from the outermost end on both the right and left side.
- ▶ Turn the rollers slightly so that the shims are located between them.
- ▶ Check to make sure that the rollers are just barely squeezing on the shims.

- If the distance between the rollers is too great:
→ »Reduction of distance between rollers« Page 83
- If the distance between the rollers is too little:
→ »Reduction of distance between rollers« Page 85

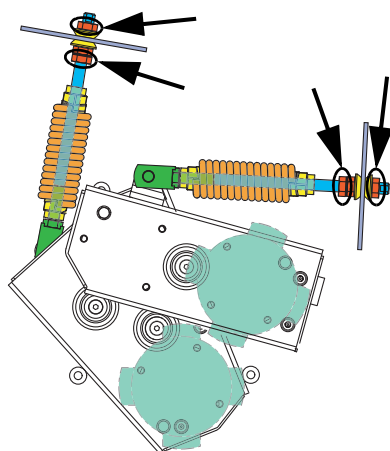

- ▶ Tighten the counter nut.

Deflector plates

The machine is fitted with 2 deflector plates, making it possible to adjust the cutting swath to suit the following chopper. The cutting swath should be as broad and even as possible.

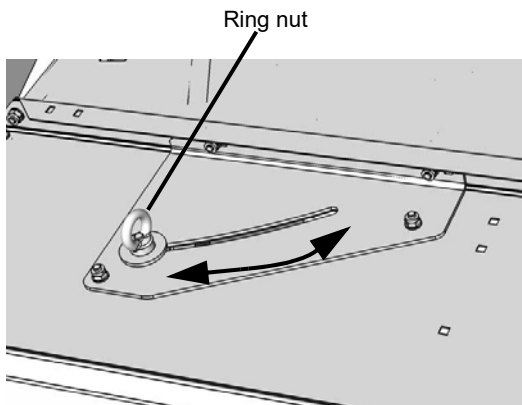

- ▶ Remove the ring nut.
- ▶ Adjust the deflector plates to the desired cutting swath.
- ▶ Tighten the ring nut on the deflector plates.

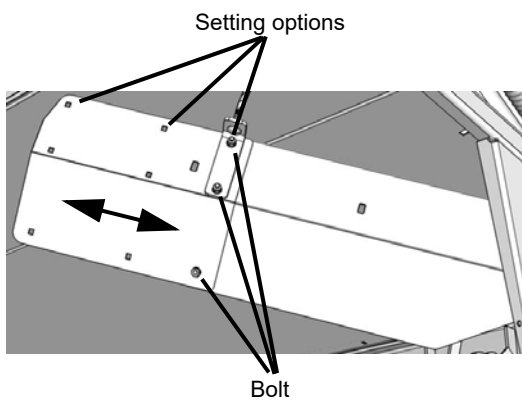

To ensure that the swath is gathered in the best possible way, it is recommended that the deflector plates be extended as close to the end plates as possible.

The deflector plates have 3 setting options.

The length of the deflector plates is set as follows:

- ▶ Remove the bolts shown and move the plates to the required length.
- ▶ Fit the bolts and tighten them.

Operation

Stubble height

The machine has 2 basic settings:

- Short stubble height.
- Long stubble height.

These 2 setting options can be combined with fitting high skids* which can be used to set the stubble height as follows:

Stubble height	Setting - see chapter:	Page
20-45 mm (0.8 - 1.8")	»Short stubble height«	88
30-50 mm (1.2 - 2")	»Long stubble height«	90
35-85 mm (1.4 - 3.3")	»Long stubble height« + 20 mm (0.8") skids fitted	90
45-100 mm (1.8 - 4")	»Long stubble height« + 40 mm (1.6") skids fitted	90
65-125 mm (2.6 - 5")	»Long stubble height« + 60 mm (2.4") skids fitted	90,165
85-150 mm (3.3 - 6")	»Long stubble height« + 80 mm (3.2") skids fitted	90,165

* Extra equipment

→ »Extra equipment« Page 164



When high skids* are fitted, the basic setting of the machine must always be on "Long stubble height".

→ »Long stubble height« Page 90

Short stubble height

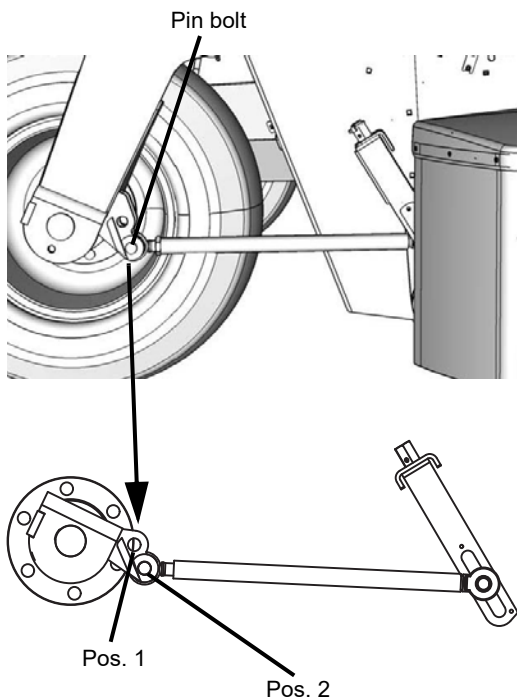

The following must be done if a short stubble height is required:

- ▶ Use a suitable tool to remove the pin from the pin bolt.
- ▶ Remove the pin bolt.

- ▶ Move the connecting link to pos. 1.
- ▶ Put the pin bolt and pin in place.
- ▶ Check the measurement shown on the connecting link.

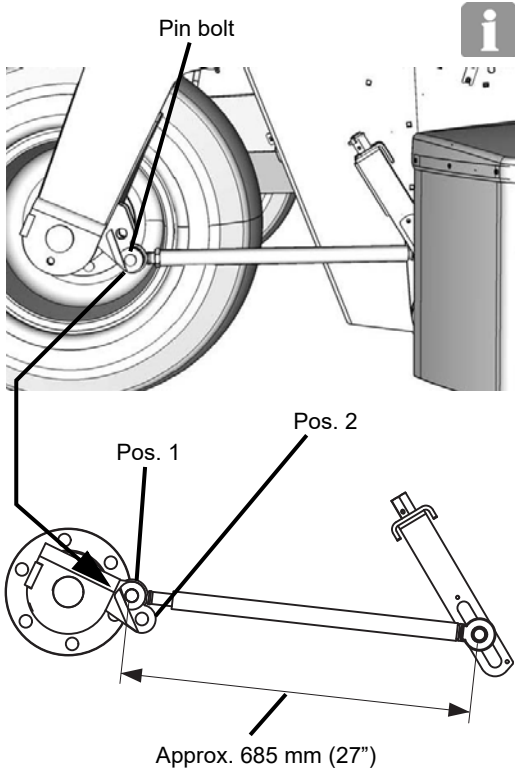

The measurement shown is only a guideline.

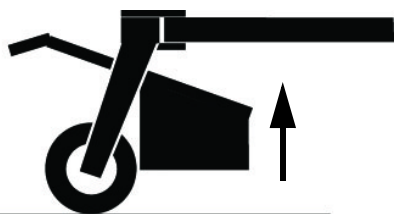

- ▶ Activate the tractor hydraulics and raise the machine's cutterbar fully.

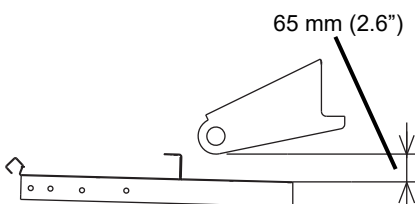

- ▶ Check the distance between the upper plate and the spring bracket on both sides of the machine.
- ▶ Adjust the connecting links, if necessary, until the distance is as shown.

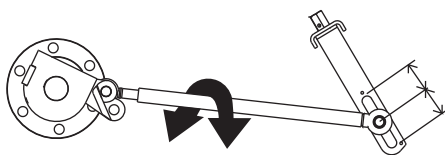

Operation

Long stubble height

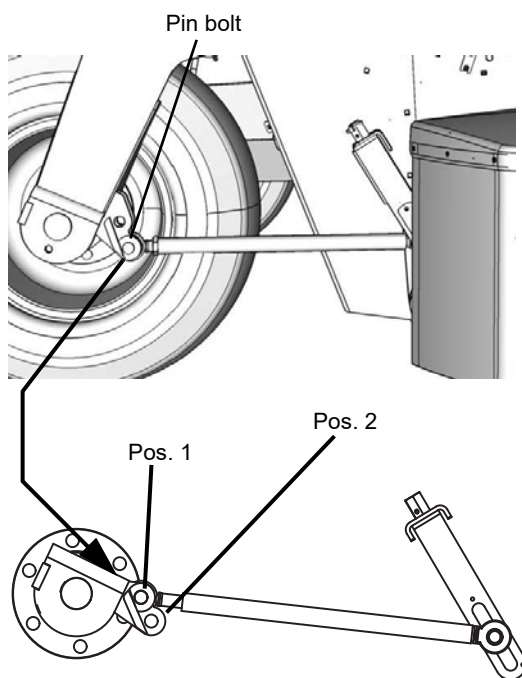

The following must be done if a long stubble height is required:

- ▶ Use a suitable tool to remove the pin from the pin bolt.
- ▶ Remove the pin bolt.

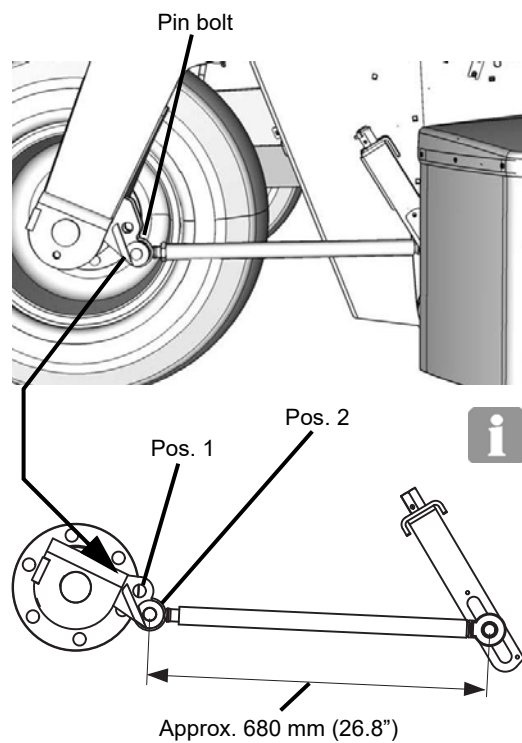

- ▶ Move the connecting link to pos. 2.
- ▶ Put the pin bolt and pin in place.
- ▶ Check the measurement shown on the connecting link.



The measurement shown is only a guideline.

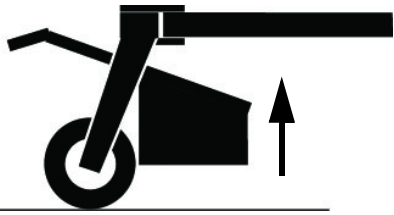

- ▶ Activate the tractor hydraulics and raise the machine's cutterbar fully.

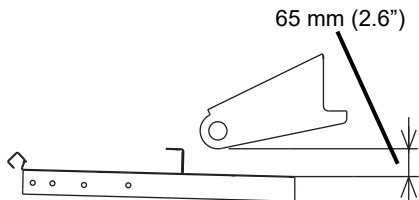

- ▶ Check the distance between the upper plate and the spring bracket on both sides of the machine.
- ▶ Adjust the connecting links, if necessary, until the distance is as shown.

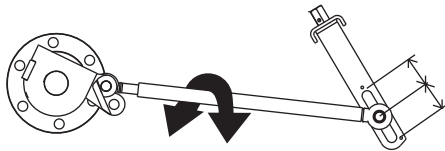

Adjusting the stubble height

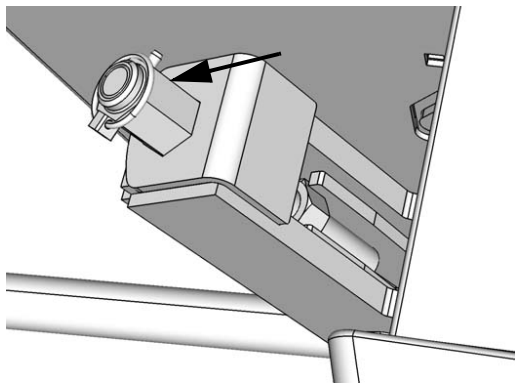

The machine has variable settings for stubble height. Stubble height is adjusted in the following way:

- ▶ Remove the linchpin.

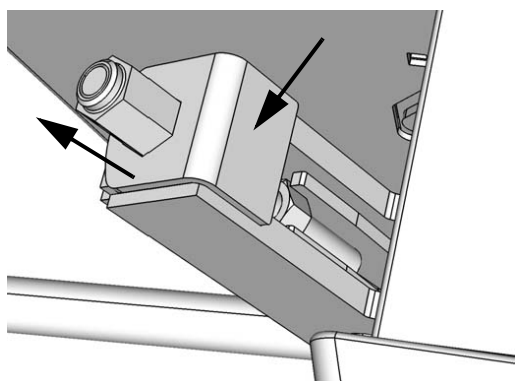

- ▶ Remove the lock plate.

Operation

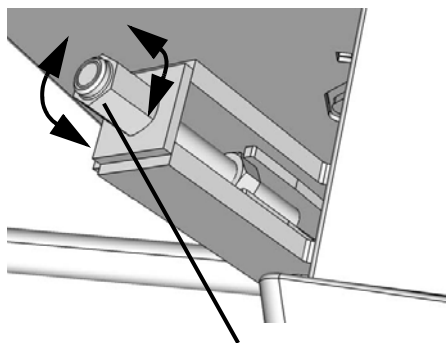

▶ Screw the bolt indicated.



- Turning the bolt clockwise increases the stubble height.
- Turning the bolt counterclockwise reduces the stubble height.

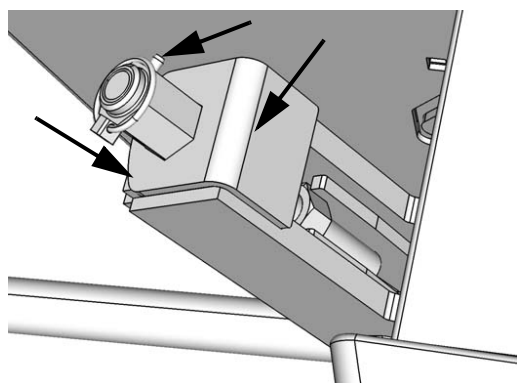
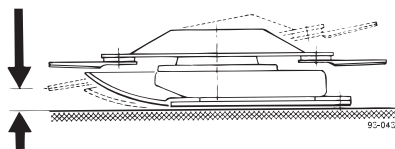

▶ Affix the lock plate.

▶ Put the linchpin in place.

Balancing

The balancing of the machine's cutting unit should be adjusted so that the downward pressure on the machine's cutting unit is about 40-60 kg (90-130 lbs).

The balancing of the cutting unit is adjusted in the following way:

- ▶ Loosen the counter nuts with the springs on both sides of the machine.

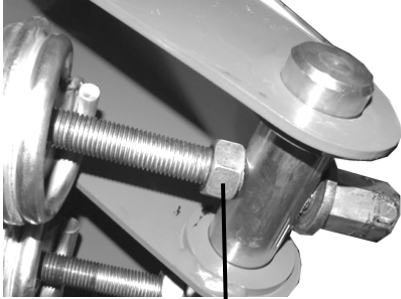

Counter nut

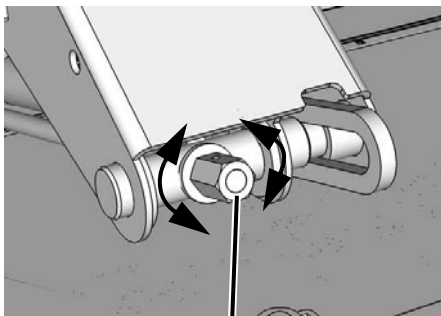

Bolt

- ▶ Screw the bolt indicated.

- When the bolt is turned clockwise the cutting unit's downward pressure decreases.
- If the bolts are screwed counter-clockwise, the cutter pressure against the ground becomes greater.

Operation

- ▶ Adjust the cutting unit's downward pressure for both springs.
- ▶ Secure the counter nuts with the springs on both sides of the machine.
- ▶ Check by lifting the cutting unit by hand, gripping both sides of the cutting unit in the places shown.

➡ When checking the suspension, position yourself in front of the cutting unit and lift the cutting unit up as shown.

➡ The weight on both sides of the cutting unit must be approximately 40-60 kg (90-130 lbs) when lifting by hand.

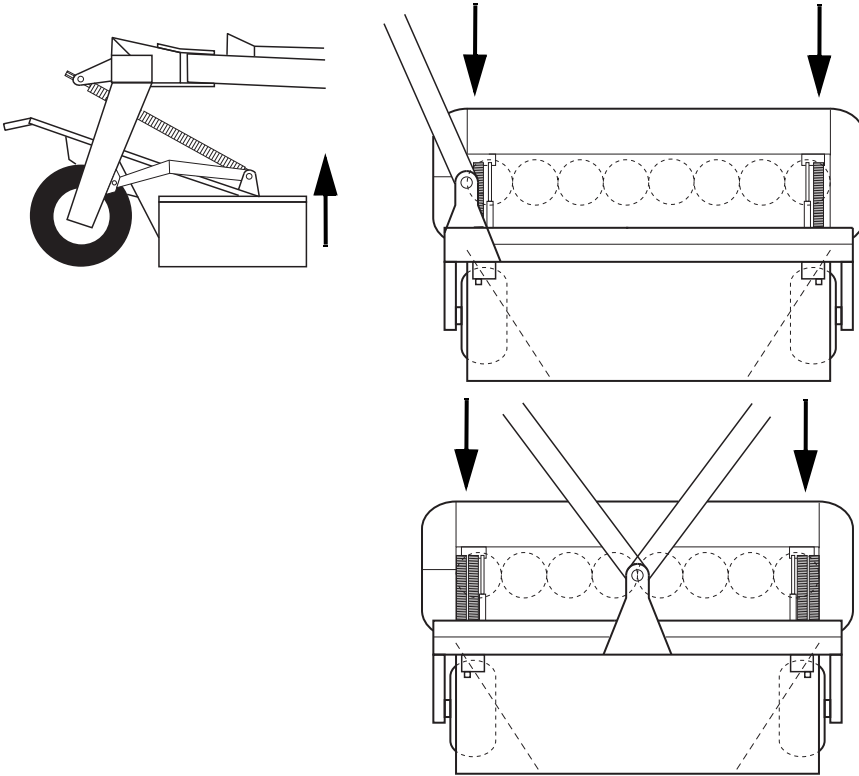

Working in the field

WARNING

Check and clear the surrounding area before starting to use machine

Before driving and using the machine the surrounding area should be checked and cleared. This prevents persons and animals in the vicinity from being harmed. If the surrounding area is not checked, it may result in serious injuries to persons or animals.

Keep away from the machine

No unauthorized persons should be close to the machine when in operation. This will ensure that no dangerous situations can arise. Persons close to the machine during operation are at risk of being severely injured.

Do not remove the protective guards

Check that all protective guards are in place before use. This ensures that the machine will offer maximum protection to the operator from the cutting blades. If the safety guards are removed or not used, it may result in serious injuries and accidents.

The guard for the cutting unit must be correctly positioned before start up

The guard for the cutting unit must be folded down and correctly positioned before the machine is started. This ensures that the machine will give maximum protection to the operator from thrown objects. Thrown objects may cause serious injuries and accidents.

80xxT-R model

Servicing is done as follows:

- ▶ Check that all guards on the machine are folded out and correctly positioned.

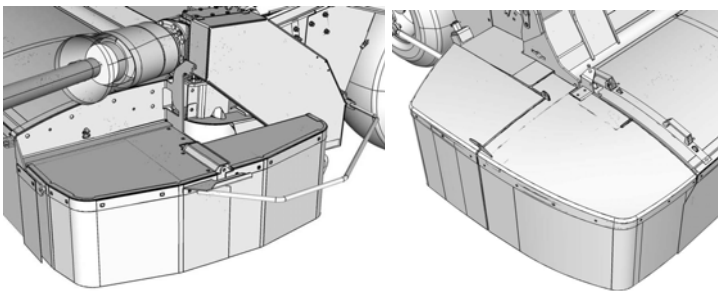

Operation

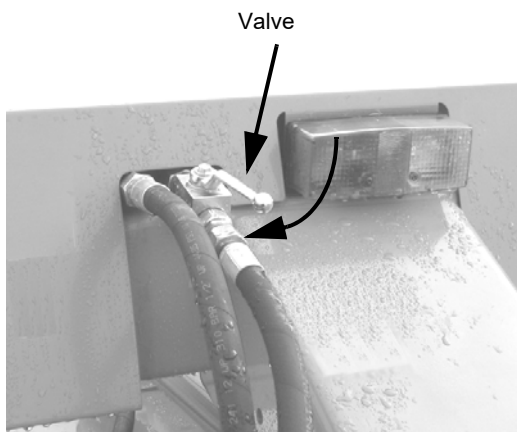

- ▶ Check that the hydraulic mechanical safety valve is open.
- ▶ Connect the tractor's P.T.O. outlet.
- ▶ Carefully increase the speed on the P.T.O. shaft to 540/1000 RPM.
→ »Number of revolutions on the P.T.O. outlet« Page 46
- ▶ Activate the tractor hydraulics and turn the machine's drawbar to the right side of the tractor.

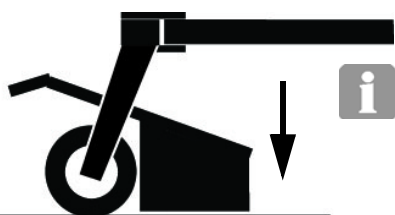
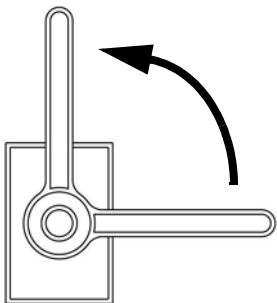

- ▶ Activate the tractor hydraulics and lower the harvester of the machine to its working position.
-  Activate the tractor hydraulics until the hydraulic cylinders on the cutting unit are fully extended to their maximum length.

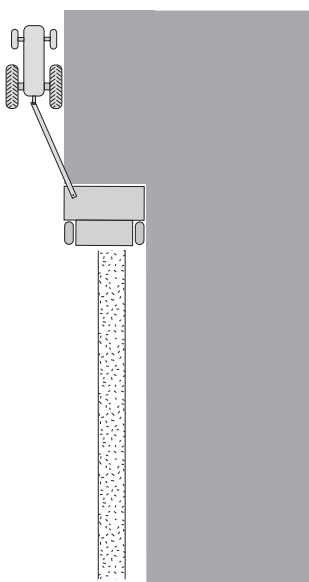

- ▶ Find a suitable driving speed for the tractor and cut the 1st swath.

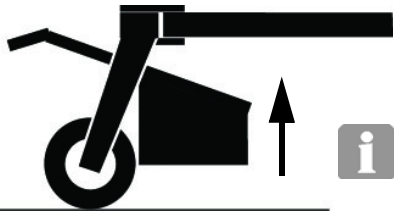

- ▶ Activate the tractor hydraulics and raise the cutting unit when turning at the headland.
- ▶ Activate the tractor hydraulics and lower the harvester of the machine to its working position.



Activate the tractor hydraulics until the hydraulic cylinders on the cutting unit are fully extended to their maximum length.

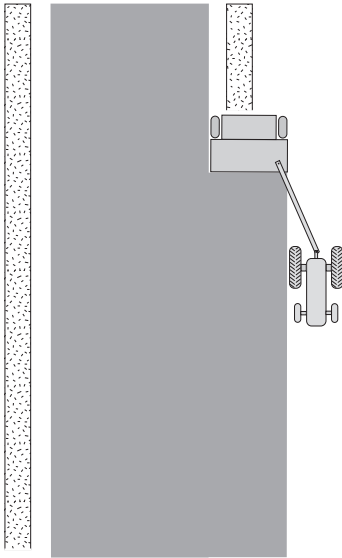

- ▶ Find a suitable driving speed for the tractor and cut the 2nd swath.

Operation

85xxT-R model

Servicing is done as follows:

- ▶ Check that all guards on the machine are folded out and correctly positioned.

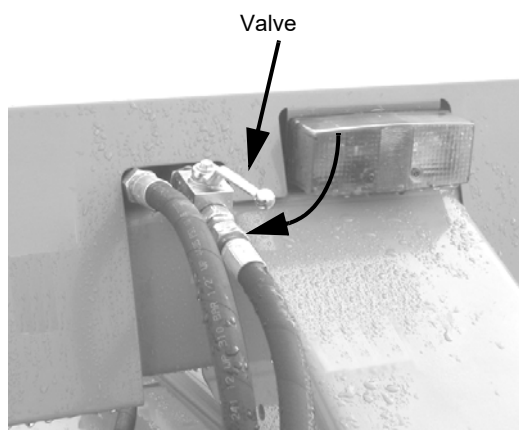
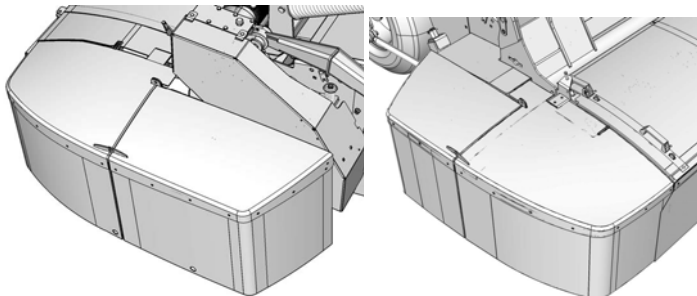

- ▶ Check that the mechanical safety valve is open.
 - ▶ Connect the tractor's P.T.O. outlet.
 - ▶ Carefully increase the speed on the P.T.O. shaft to 540/1000 RPM.
- »Number of revolutions on the P.T.O. outlet« Page 46

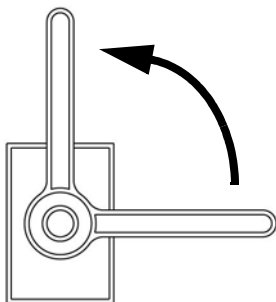

- ▶ Activate the tractor hydraulics and turn the machine tension rod out to the left side of the tractor.

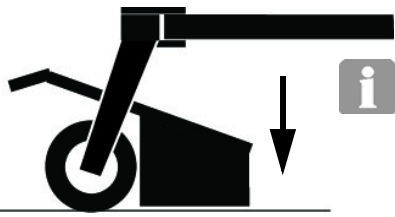

- ▶ Activate the tractor hydraulics and lower the harvester of the machine to its working position.

i Activate the tractor hydraulics until the hydraulic cylinders on the cutting unit are fully extended to their maximum length.

- ▶ Find a suitable driving speed for the tractor and cut the 1st swath.

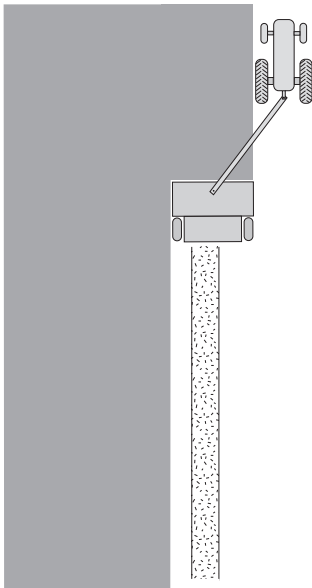

- ▶ Activate the tractor hydraulics and raise the cutting unit when turning at the headland.

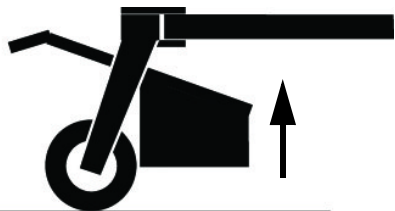

- ▶ Activate the tractor hydraulics and turn the machine's drawbar to the right side of the tractor.

Operation

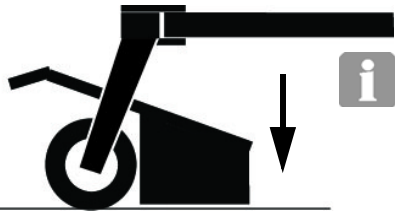

- ▶ Activate the tractor hydraulics and lower the harvester of the machine to its working position.



- ▶ Activate the tractor hydraulics until the hydraulic cylinders on the cutting unit are fully extended to their maximum length.

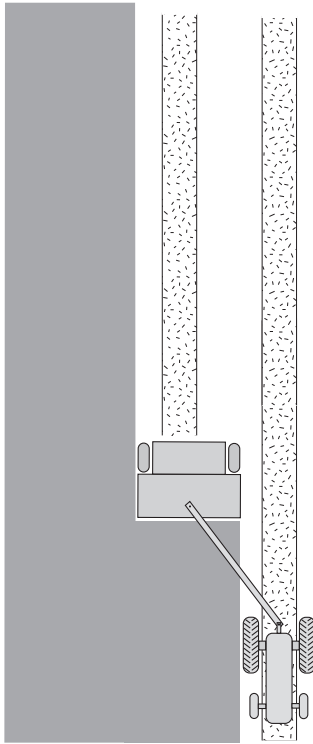

- ▶ Find a suitable driving speed for the tractor and cut the 2nd swath.

Safety

WARNING

Read the safety instructions carefully before driving on public road

Before driving on public roads, you must read the safety instructions carefully.

→ »Transport on public roads« Page 22

This will ensure that dangerous situations and accidents are avoided. Lack of information can cause accidents.

General

WARNING

- Comply with the local laws concerning lights, warning reflective requirements.
- The driver and/or the owner of the machine has the responsibility of complying with local requirements for use on public roads.
- The tractor's maneuverability should not be adversely affected. The tractor's steering shaft should bear at least 20% of the tractor's net weight.
- The tractor's braking distance should not be reduced. At least 50% of the vehicle's total weight must rest on the braked wheel.
- Carrying passengers on the machine is strictly prohibited.

Before traveling on public roads

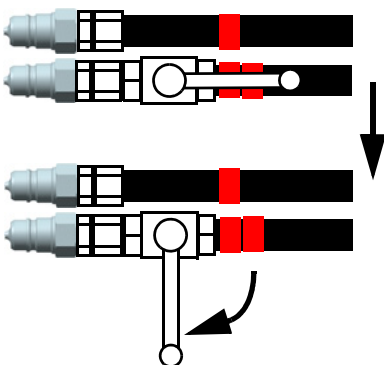

- All of the hydraulic functions of the machine should be placed in neutral and in locked position.
- The tractor hydraulic system must be disconnected.
- The mechanical safety valve for the drawbar shall be closed.
- Be sure there are no children in the machine's hazard area.
- Check the surrounding area before starting the machine.

Safety chain

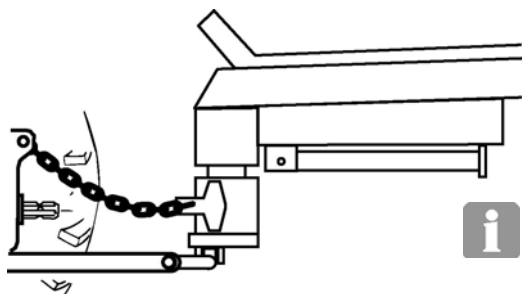

WARNING

Safety chain

When driving on public roads, the machine must always be secured with a safety chain between the tractor and the machine. Use a safety chain with a reinforcement suited to at least the total weight of the machine. If the machine should accidentally become detached, this could cause serious injury or death.

- ▶ Attach the safety chain between the tractor and the machine.



Choose an appropriate length of the chain so that it does not negatively affect the movement of the drawbar and hang too low.



- Observe the national regulations concerning the length and the attachment of safety chains.

→ »Safety chain« Page 56

Check

Before traveling on the road the machine should be checked according to this check list:

- Is the machine in the transport mode?
- Is the mowing device lifted all the way up?
- Are the machine side guards folded in?

→ »Guard« Page 64

- Are all hydraulic functions in neutral?
- Are the machine attachment points secured by a pin?
- Is the safety chain between the tractor and the machine installed?
- Is the tire pressure of the transport wheels correct?
- Does the lighting kit of the machine work correctly?

Traveling on public roads

- Check the area around the machine before you start. Be sure there are no children in the machine's hazard area.
- Do not exceed the maximum permitted speed.
- Adjust the speed according to the road conditions.
- Avoid sudden sideways movement of the machine.
- Make sure that steering and braking ability is sufficient.

Speed when driving on public roads



When driving on public roads with this machine, the speed must be less than 40 km/h (25 mph).

Before cleaning



WARNING

Higher risk when cleaning the equipment

When cleaning, there is an increased risk of injury. Attention when carrying out cleaning work protects your own and others safety. Failure to follow the safety instructions may result in serious injuries.

Therefore, do the following before cleaning:

- Disengage the P.T.O. on the tractor.
- Place the hydraulic controls in neutral.
- Stop the tractor.
- Remove the ignition key.
- Set the parking brake.

Failure to secure the tractor to prevent it from rolling could endanger lives.

Disconnect the power when cleaning the machine

Always disconnect the power before you start cleaning the machine. This will prevent short circuits and damage to the electric circuit. There is a risk of burns and other serious injuries if the electrical systems short circuit.

Protect your body and face when cleaning the machine

Wear the correct protective gear for body and face when cleaning the machine.

This will protect your body and face from dirt and oil splashes. Insufficient protection of body and face can lead to severe skin and eye injuries.

Before starting to clean the machine do the following:

- Open the guard around the cutting unit.
- Remove all loose material from the machine.

Cleaning



Use the correct cleaning agents

Use only PH neutral cleaning agents when cleaning the machine. PH neutral cleaning agents give your machine maximum protection. Cleaning agents with either high or low PH value can corrode plastic, rubber and varnished surfaces.

- High pressure cleaning equipment may be used to clean. However, the area around the bearings should be cleaned using gentle squirts of water.
- Hydraulic components should only be cleaned with gentle squirts of water to protect the gaskets.

After cleaning

- Let the remaining water run off for about 1 hour.
- Remove any water which has collected behind the guards.

Parking and Storage

Before storage

At the end of the season, the machine should be prepared for storage:

- ▶ Check and tighten all bolts.
- »Torque moment« Page 178
- ▶ Repair any damaged components.
- ▶ Replace any defective components.
- ▶ Repair any damage to the paint work.
- ▶ Reduce the air pressure in the tires.
- ▶ Lubricate the machine following the program.
- »Maintenance intervals« Page 112

Parking/ disconnection

WARNING

Disconnection between the machine and the tractor

There is an increased risk of injury from crushing when disconnecting the machine from the tractor. Paying full attention when disconnecting ensures your safety and that of others. Failure to follow the safety instructions may result in serious injuries.

Therefore, when disconnecting make sure that:

- The machine is placed upon a horizontal and level surface.
- The P.T.O. is disengaged.
- The hydraulic controls is in neutral.
- The tractor is stopped.
- The ignition key is removed.
- The parking brake is set.
- The tractor cannot roll after being disconnected.
- Children and unauthorized persons must never be allowed near the machine.

Failure to secure the tractor to prevent it from rolling could endanger lives.



Hydraulics



Only disconnect the hydraulics when system is depressurized

You should only disconnect the hydraulic hoses from the tractor's hydraulics if the hydraulic systems on both tractor and machine are depressurized. There is a risk that the machine will move accidentally. Unintentional movement of the machine may result in serious injuries.

Avoid physical contact with hydraulic oil

Hydraulic oil contains additives that under certain circumstances can have serious consequences for your health. Therefore, when handling hydraulic oil be aware of the following:

- Avoid direct contact with hydraulic oil. It can cause injuries to the skin.
- Protect your skin with barrier cream or protective gloves.
- Never use oil or lubricants to clean your hands.
- Clothes contaminated with oil should be changed immediately.
- Oily cloths should not be kept in your pockets.
- Seek medical help for skin injuries or if you come into contact with hydraulic oil under pressure, as such injuries can cause gangrene.

Parking and Storage

Storage

Once the season has ended, the machine is prepared for long-term storage. Do the following:

- Clean the machine thoroughly.

→ »Cleaning« Page 104

- Change the oil in all the machine's transmissions.

→ »Lubricants« Page 177

- The hydraulic quick coupling should either be covered with a dust cap or placed in a small plastic bag.
- The P.T.O. shaft should be cleaned, oiled and stored somewhere dry so as to avoid damage or corrosion.
- Always check that the machine's safety equipment is not worn or damaged.
- Always park the machine with the cutting unit lowered and its wheels on the ground.



If the machine's cutting unit is parked in the raised position for a prolonged period, there is a risk that the cutting unit may sink unevenly in the machine's hydraulic cylinder. This will cause problems when the machine's hydraulic system is coupled to the tractor.

→ »Checking the cutting unit« Page 62

- Bleed as much excess hydraulic pressure from the cylinders and hoses as possible.
- Place the machine in a ventilated machine room.
- Both of the machine's wheel axles should be supported on blocks so that the wheels are lifted off the ground.

Safety



WARNING

The machine shall be secured when parked

The machine must be correctly secured when parked in storage. A correctly secured machine prevents persons from being run over and other serious accidents. If the machine is not properly secured when parked it can result in serious injuries and death.

Therefore, when disconnecting make sure that:

- the machine is in working position.
- The machine is placed upon a horizontal and level surface.
- The P.T.O. is disengaged.
- Lower the implement to the ground.
- The hydraulic controls is in neutral.
- The tractor is stopped.
- The ignition key is removed.
- The parking brake is set.
- The tractor cannot roll after being disconnected.
- Children and unauthorized persons must never be allowed near the machine.

Failure to secure the tractor to prevent it from rolling could endanger lives.



For your own safety

Specific safety information



Valve

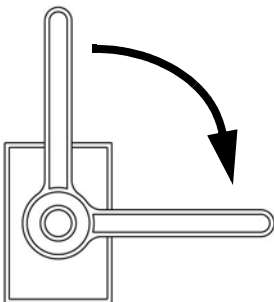
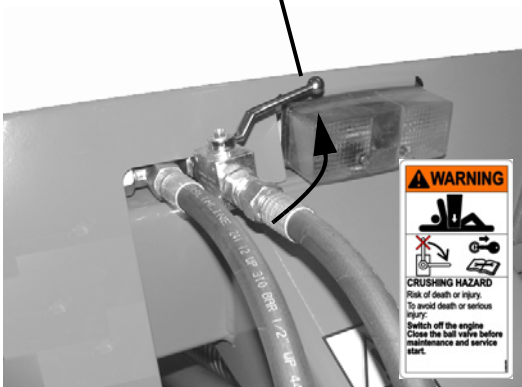

WARNING

Comply with the service and maintenance intervals given in the instructions

Comply with the intervals for service and maintenance as given in the instructions. By complying with the maintenance intervals you assure that the machine will operate without malfunctions and give maximum protection to the surroundings. An incorrectly maintained machine is a danger to personnel and environment.

WARNING

- Repair and maintenance work should only be carried out by persons with the necessary professional knowledge and the correct tools.
- The P.T.O. on the tractor should be disconnected, and the motor should be stopped.
- Make sure that the hand brake is applied and the ignition key has been removed from the tractor.
- Make sure the machine is secured with wedges under the wheels before starting work.
- No one should be in between the tractor and the machine if the machine has not been secured.
- Always use original spare parts on the machine.
- Never use a pressurized grease gun spray to lubricate the machine bearings.
- When carrying out any type of service and maintenance work where the machine's cutting unit is raised up, the mechanical safety valve must always be closed.

Lubrication safety and use of oil



WARNING

Oils and lubricants contain additives that under certain circumstances can have serious consequences for your health. Therefore, when using oil and lubricants be aware of the following:

- Avoid direct contact with these agents. It can cause injuries to the skin.
- Protect your skin with barrier cream or protective gloves.
- Never use oil or lubricants to clean your hands.
- Clothes contaminated with oil should be changed immediately.
- Oily cloths should not be kept in your pockets.
- Used oil must be collected and be delivered to a disposal company, where the oil will be processed according to the governing regulations.
- Seek medical help if skin is injured by oil or lubricants.



General instructions

These instructions concern general maintenance work. Specific maintenance work procedures for each machine will be described later. When performing any maintenance work the machine must be secured in the transport position. If the work position is necessary for performing maintenance work, you will find appropriate instructions to cover this.



Working with the grease gun

One or two pumps of the grease gun is sufficient for lubrication. If you feel resistance after just one pump of the grease gun, do not apply more grease to the bearings. When too much grease is applied, bearings drift apart. This can result in dust and dirt entering the bearings and causing premature wear and tear.

Basic

This table contains explanations of the most important maintenance terms.

Work	Performance
Lubricating with oil can	Apply oil to the moving parts. Use only authentic products. → »Technical information« Page 177
Lubricating with grease gun	Use only authentic products. → »Technical information« Page 177
Oil change	Use only authorized oil products. Using used oil is dangerous for your health and is strictly prohibited. → »Technical information« Page 177
Replace	Replace the part in question according to the instructions.
Check	Check the part in question according to the instructions. The check is sometimes related to the replacement of the part in question
Complying with the maintenance intervals	All specifications are based on an average usage of the machine. If heavily loaded, e.g. machine pools, maintenance should be carried out on a more regular basis. In work conditions producing high levels of dust, maintenance should also be carried out on a more regular basis.

Torque for screw connections

→ »Torque moment« Page 178

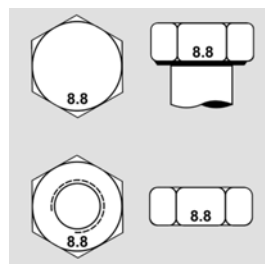

Maintenance

Maintenance intervals

* 85xxT-R mode only.

		Daily	Every 200 hours of operation / once annually	As required	Oil change	Lubrication	Check	Replacement	Page
Hydraulic hoses every 6 years								•	20
Cutting unit	Blades	•					•		117
				•				•	148
	Cutting disc	•					•		120
				•				•	151
	Stone guard and counter blade	•					•		124
				•				•	154
	Tarpaulin	•					•		127
				•			•	162	
Transmission Cutterbar	After 50 working hours				•				115
	Cutterbar		•		•				130
	Swivel gear		•		•				136
	Main gear		•		•				133
	Center gear*		•		•				135
	Roller gear		•		•				137
Lubrication	Drive shaft		•			•			144
	Bearings		•			•			144
	Moving joints		•			•			145
Cone	External	•					•		121
	Internal		•				•		139
Rotor / Roller	Y-fingers	•					•		122
				•				•	156
	Rollers	•					•		123
	V-belt	•					•		126
				•			•	157	
Other	Drive shaft		•				•		140
				•				•	159
	Center gear*		•				•		143
	Wheel	•					•		128
					•			•	162

WARNING

Safety in connection with maintenance work on the machine

When working on the machine the tractor must be stopped and secured. This prevents the PTO shaft from suddenly starting to rotate.

Failure to follow the safety instructions may result in serious injuries.

When working on the machine:

- The P.T.O. is disengaged.
- Lower the implement to the ground.
- The tractor engine must be stopped.
- The ignition key is removed.
- The parking brake is set.
- Secure the tractor to prevent it from rolling.



Failure to secure the tractor to prevent it from rolling could endanger lives.

Always use original spare parts on the machine

Always use original spare parts. Original spare parts should be used for safety reasons. The manufacturer's warranty becomes void if non-original spare parts are used.

Make sure that all safety devices are in place

Check that all safety devices are in place. This ensures that the machine will offer maximum protection to the operator from the cutting blades. If the safety devices are disassembled or not used, it may result in serious injuries and accidents.

P.T.O. shaft check



Refer to the manufacturer's user manual included with the P.T.O. shaft.

→ »User manual for the P.T.O. shaft« Page 43

Swivel gear



Performed only if the swing gear has been dismantled and turned.

→ »Number of revolutions on the P.T.O. outlet« Page 46

The oil level is checked as follows:

The upper part of the swivel hitch

- ▶ Remove oil plug 2.
- ▶ Check that the oil is filled all the way up to the hole.
- ▶ When topping up, remove the oil plug 1.
- ▶ Fill the oil through the hole for oil plug 1.
- The correct oil level is reached when the oil reaches the edge of the hole for oil plug 2.
- ▶ Fit oil plug 1 and 2.

→ »Lubricants« Page 177

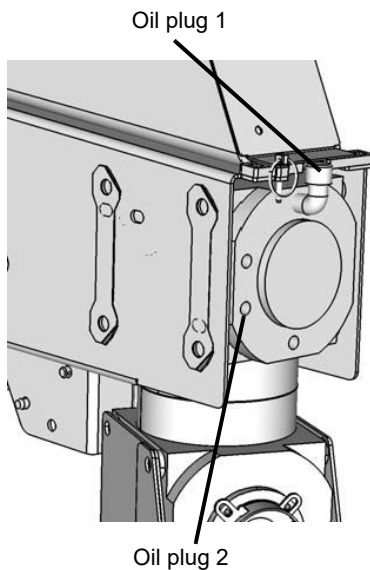

The lower part of the swivel hitch

- ▶ Remove oil plug 5.
- ▶ Check that the oil is filled all the way up to the hole.
- ▶ When topping up, remove the oil plug 4.
- ▶ Fill the oil through the hole for oil plug 4.
- The correct oil level is reached when the oil reaches the edge of the hole for oil plug 5.
- ▶ Fit oil plug 4 and 5.

→ »Lubricants« Page 177

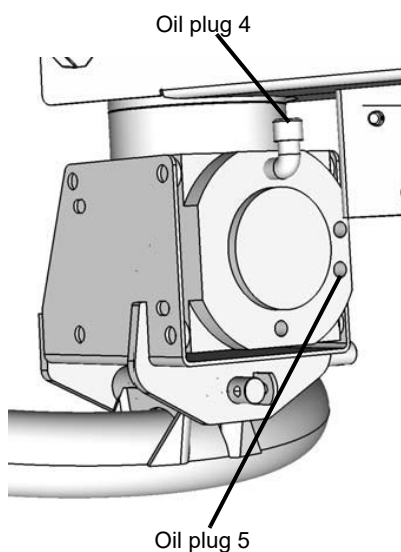

After 50 hours of operation



WARNING

Safety in connection with maintenance work on the machine

When working on the machine the tractor must be stopped and secured. This prevents the PTO shaft from suddenly starting to rotate.

Failure to follow the safety instructions may result in serious injuries.

When working on the machine:

- The P.T.O. is disengaged.
- Lower the implement to the ground.
- The tractor engine must be stopped.
- The ignition key is removed.
- The parking brake is set.
- Secure the tractor to prevent it from rolling.

Failure to secure the tractor to prevent it from rolling could endanger lives.

Be careful when using oil

Use barrier cream or protective gloves when handling oil. It will protect your hands against skin injuries. Direct contact with the oil could lead to serious skin injuries

Use the correct oil type

Always use the correct oil type for the transmission. This will ensure the transmission has a long service life. Using the incorrect oil type may damage the transmission.

Maintain correct oil level

The max. and min. oil level indicators on the transmission must not be exceeded. Correct transmission oil level will ensure a long service life. Incorrect oil levels can cause the transmission to overheat, resulting in serious damage.

After 50 hours of operation, the oil in the machine needs to be changed:

	Page
»Cutterbar«	130
»Swivel gear«	136
»Main gear«	130
»Center gear« (85xxT-R mode only)	135
»Rollers«	137

Daily



WARNING

Safety in connection with maintenance work on the machine

When working on the machine the tractor must be stopped and secured. This prevents the PTO shaft from suddenly starting to rotate. Failure to follow the safety instructions may result in serious injuries.

When working on the machine:

- The P.T.O. is disengaged.
- Lower the harvester to the ground.
- The tractor engine must be stopped.
- The ignition key is removed.
- The parking brake is set.
- Secure the tractor to prevent it from rolling.



Failure to secure the tractor to prevent it from rolling could endanger lives.

Blades

WARNING

Check the machine blades on a regular basis

The machine's blades must be regularly inspected. Worn or damaged blades can unbalance the rotating parts. Vibrations can cause damage to the machine.

→ »Maintenance intervals« Page 112

The blades are checked as follows:

- ▶ Activate the tractor hydraulics and raise the machine's cutterbar fully.



- ▶ Close the mechanical safety valve.

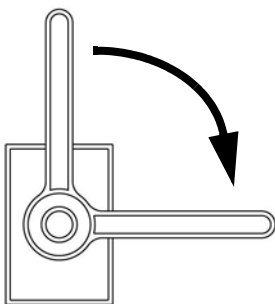
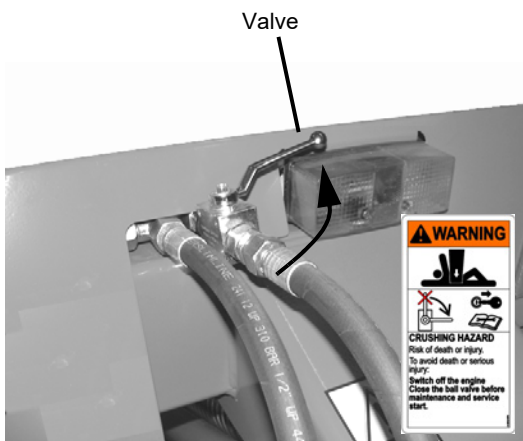

Maintenance

- ▶ Remove the linchpin.
- ▶ Open the front guard.
- ▶ Suspend the guard in the chain as shown.

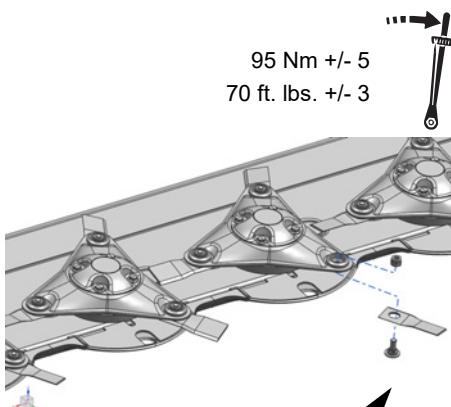
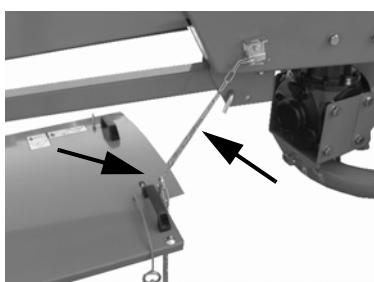
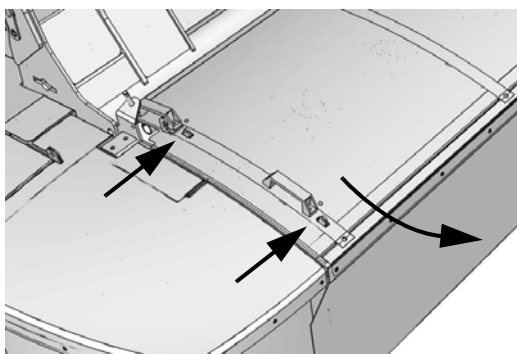

- ▶ Turn the cutting discs by hand until the damaged blade is in the position shown.
- ▶ Inspect the condition of the blades for wear.
- ▶ Inspect the bolt for damage or wear.
 - If the bolt is damaged or worn, it must be changed.



The minimum diameter of the bolt must not be less than $\phi 16$ mm (0.6").

→ »Blades« Page 148

- ▶ Check that the bolt is fully tightened.
- ▶ If not, tighten the bolts to the indicated torque.

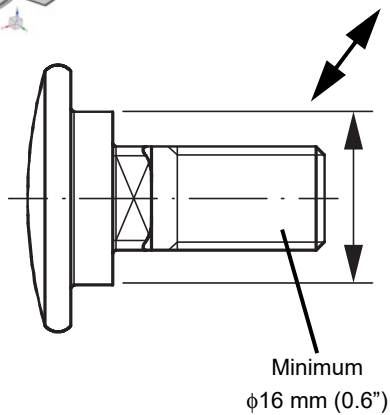

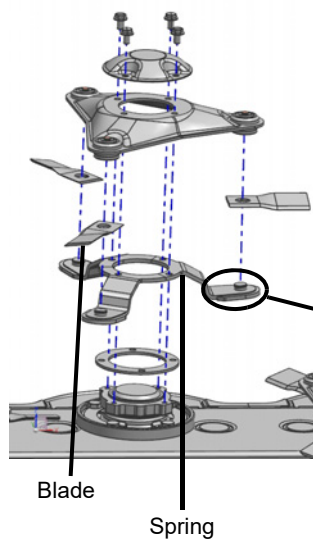

i If the machine is equipped with quick-changing blades*, the same requirements apply as for the wear and tear of bolts.
→ »Blades« Page 148

* Extra equipment
→ »EXPRESS« Page 166

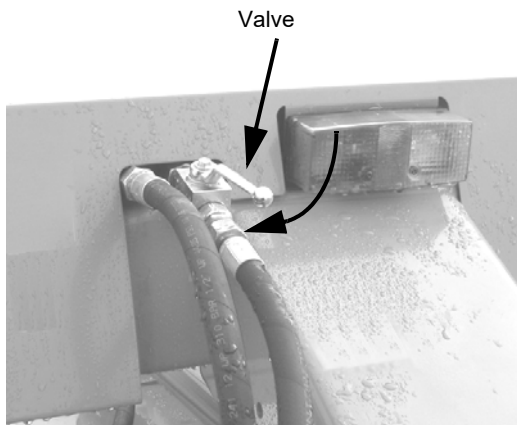
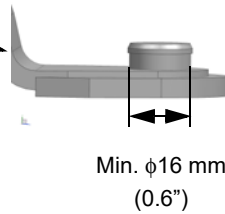

- ▶ Close the front guard.
- ▶ Remove the linchpin.
- ▶ Open the mechanical safety valve.
- ▶ Activate the tractor hydraulics and lower the cutting unit of the machine.

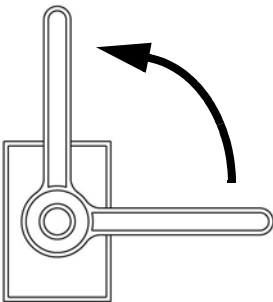

Cutting disc

→ »Maintenance intervals« Page 112
The cutting discs are checked as follows:

- ▶ Inspect the condition of the cutting discs for deformities and cracks.
▶ Damaged and/or deformed cutting discs must be replaced immediately.
- ▶ »Cutting disc« Page 151
- ▶ Tighten the cutting disc to the indicated torque.

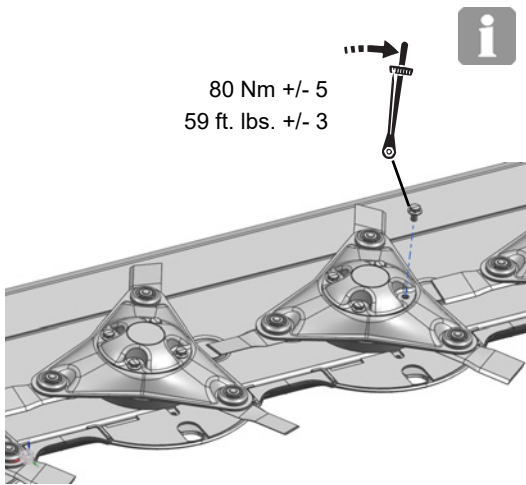

Cone

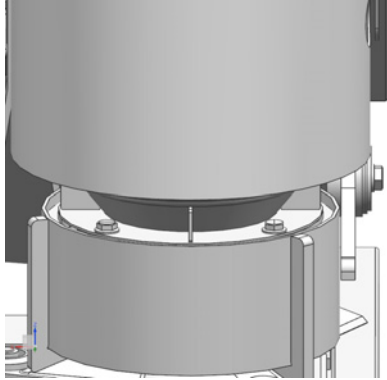

WARNING

Check the machine's cones on a regular basis

The machine's cones must be inspected and cleaned regularly. The accumulation of residual crops can cause an imbalance in the rotating parts. Vibrations can cause damage to the machine.

→ »Maintenance intervals« Page 112

An external check of the cones is carried out in the following way:

- ▶ Remove dirt from the cones on both sides of the machine.

Y-fingers

Only T model

→ »Maintenance intervals« Page 112

The machine's Y-fingers are checked as follows:

- ▶ Activate the tractor hydraulics and raise the machine's cutterbar fully.
- ▶ Check the rotor for loose fingers.
- ▶ Check the lock plate by the bolt.

If the lock plate is damaged or cracked, it must be changed.

→ »Y-fingers« Page 156

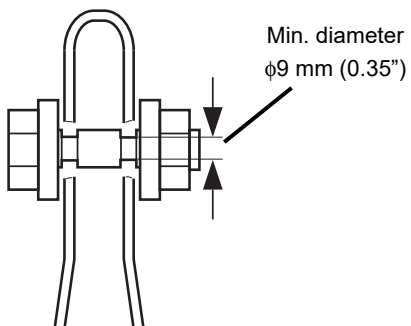
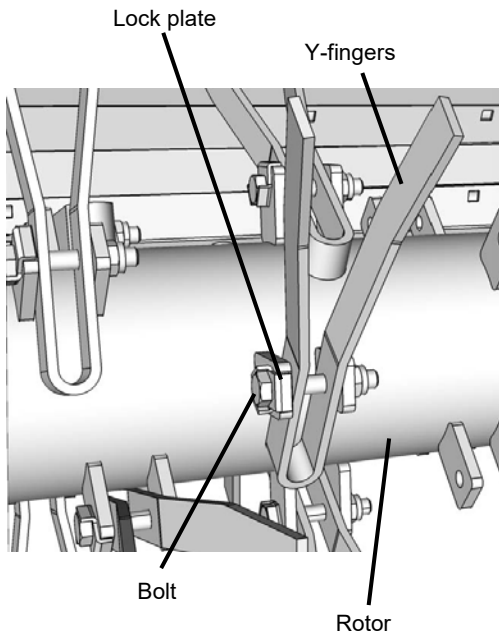

- ▶ Inspect the bolt for damage or wear.
- If the bolt is damaged or worn, it must be changed.

i The minimum diameter of the bolt must not be less than $\phi 9$ mm (0.35").

→ »Y-fingers« Page 156

- ▶ Check that the bolt is fully tightened.
- ▶ If not, tighten the bolt some more.

i The Y-fingers should be able to move freely.

Rollers

Only R model

→ »Maintenance intervals« Page 112

The rollers are checked as follows:

- ▶ Inspect the rollers for jammed foreign objects.

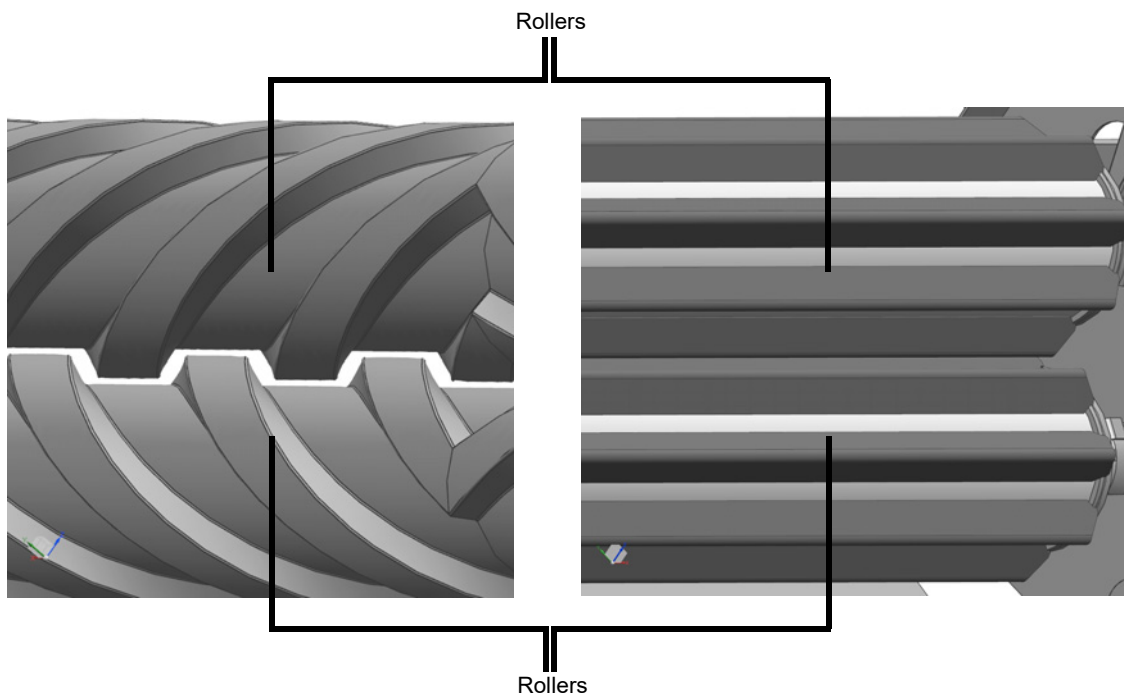

Maintenance

Stone guard and counter blade

WARNING

Proper support for the machine is vitally important

When working under the machine, the machine must be properly supported. If the machine is not properly supported, there is a great danger that the machine will tip over onto people. Insufficient support of the machine may result in serious injuries and death.

→ »Maintenance intervals« Page 112

The stone guard and counter blade are inspected as follows:

- ▶ Activate the tractor hydraulics and raise the machine to its fullest extent.



- ▶ Close the mechanical safety valve.

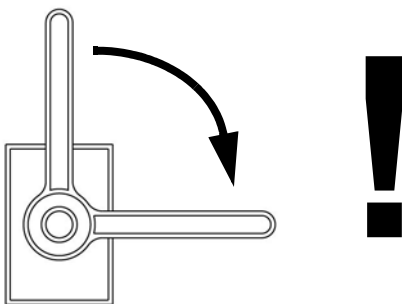
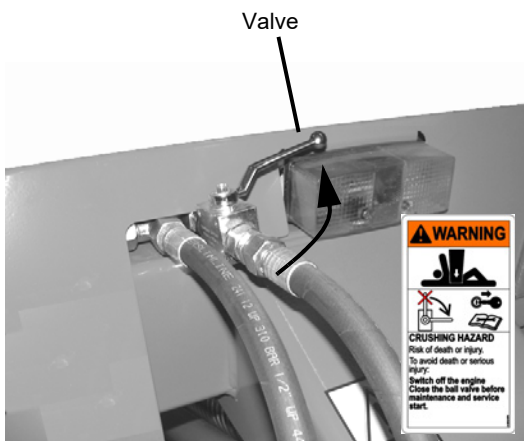

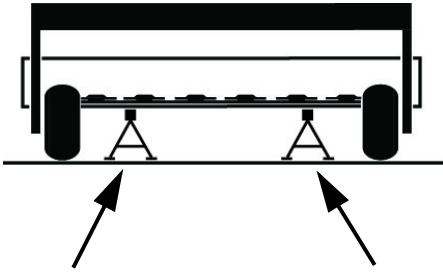

- ▶ Place a suitable support under the machine's cutting unit.



It is important that the machine is correctly secured with a sturdy support before work is started.

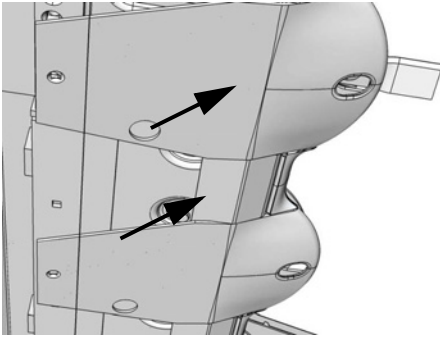

- ▶ Carry out a visual inspection of the machine's stone guard and counter blade for wear.



Stone guards and counter blades with visible holes caused by heavy wear must be replaced immediately.

→ »Stone guard and counter blade« Page 154

- ▶ Remove the support.
- ▶ Open the mechanical safety valve.
- ▶ Activate the tractor hydraulics and lower the cutting unit of the machine.

Maintenance

V-belt

→ »Maintenance intervals« Page 112

The V-belts on the rotor must be regularly checked.
The V-belts for the rotor transmission is checked as follows:

- ▶ Activate the tractor hydraulics and lower the cutting unit of the machine.
- ▶ Remove the guard.

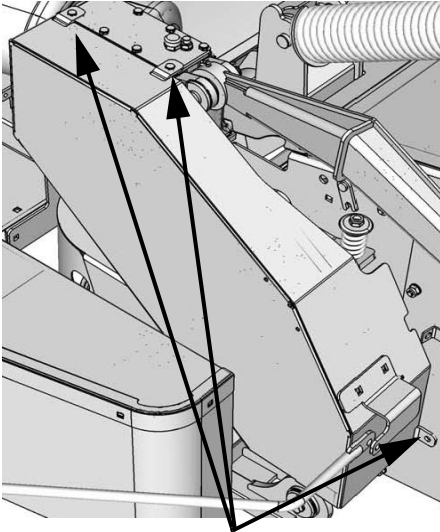

Bolt

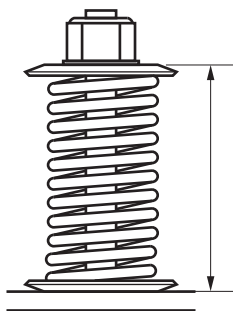

75 mm (3")

- ▶ Use a tape measure or similar to measure the springs as shown.
- ▶ The springs are tightened with a bolt to the measurement shown.
- ▶ Affix the protection.

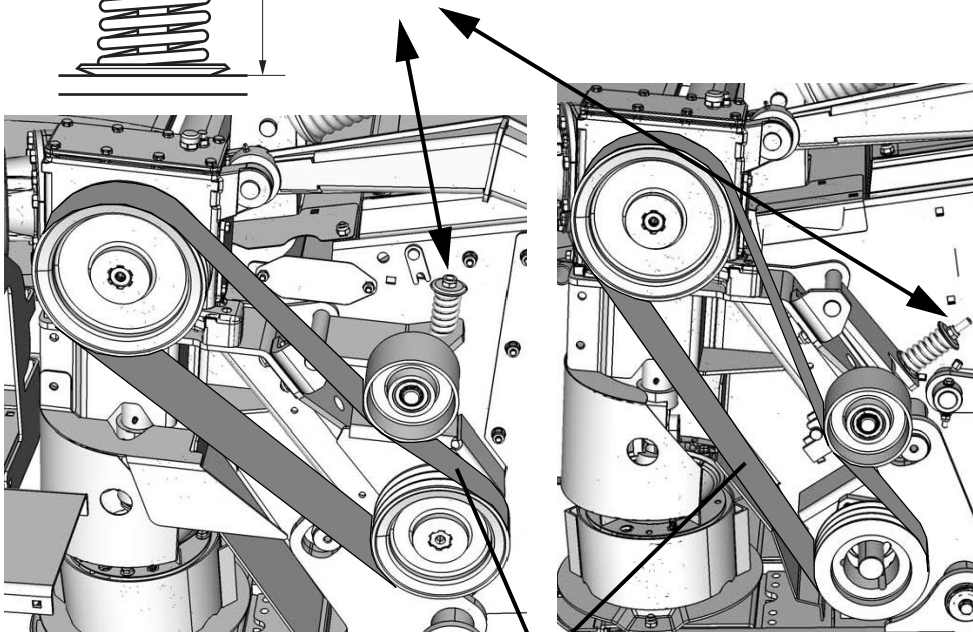

V-belt

Tarpaulin

The tarpaulin and auxiliary protection around the cutterbar must be charged regularly.

The tarpaulin and auxiliary protection are inspected as follows:

- ▶ Do a visual inspection of machine protection for holes and other damage.

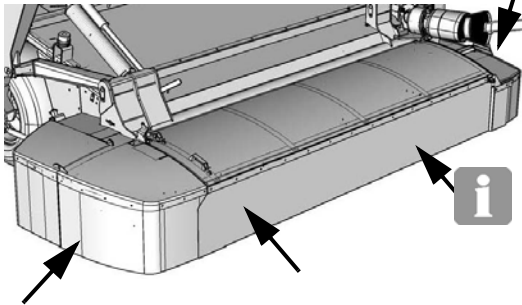

i Protection with visible holes and other damage must be replaced immediately.

→ »Tarpaulin« Page 162

Maintenance

Wheel

WARNING

Do not drive with worn or damaged tires

Do not drive with worn or damaged tires. Replace worn or damaged tires immediately. There is a high risk of accidents when driving on public roads with worn or damaged tires.

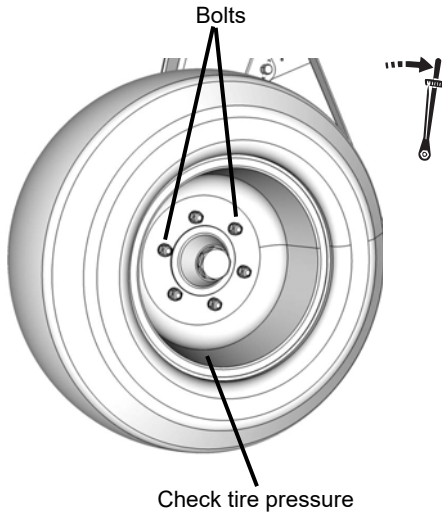

→ »Maintenance intervals« Page 112

- ▶ Use a suitable torque wrench adjusted to the torque shown in the table below.
- ▶ Check all the bolts on the wheels and tighten them to the torque shown.
- ▶ Check the tire pressure and, if necessary, top up the tire to the pressure shown in the table below.

Model	Tire Dimension	Tire pressure bar (psi)	Bolt torque Nm (ft lb)
8028	15.0/55 -17	2.6 (37)	300 (220)
8032-8532			
8036-8536			
8540-8547			

Every 200 hours of operation

or once annually



WARNING

Safety in connection with maintenance work on the machine

When working on the machine the tractor must be stopped and secured. This prevents the PTO shaft from suddenly starting to rotate. Failure to follow the safety instructions may result in serious injuries.

When working on the machine:

- The P.T.O. is disengaged.
- Lower the implement to the ground.
- The tractor engine must be stopped.
- The ignition key is removed.
- The parking brake is set.
- Secure the tractor to prevent it from rolling.

Failure to secure the tractor to prevent it from rolling could endanger lives.

Be careful when using oil

Use barrier cream or protective gloves when handling oil. It will protect your hands against skin injuries.

Direct contact with the oil could lead to serious skin injuries

Use the correct oil type

Always use the correct oil type for the transmission. This will ensure the transmission has a long service life. Using the incorrect oil type may damage the transmission.

Maintain correct oil level

The max. and min. oil level indicators on the transmission must not be exceeded. Correct transmission oil level will ensure a long service life. Incorrect oil levels can cause the transmission to overheat, resulting in serious damage.

WARNING

Proper support for the machine is vitally important

When working under the machine, the machine must be properly supported. If the machine is not properly supported, there is a great danger that the machine will tip over onto people. Insufficient support of the machine may result in serious injuries and death.

Maintenance

Cutterbar

→ »Maintenance intervals« Page 112

The oil in the cutterbar is changed as follows:

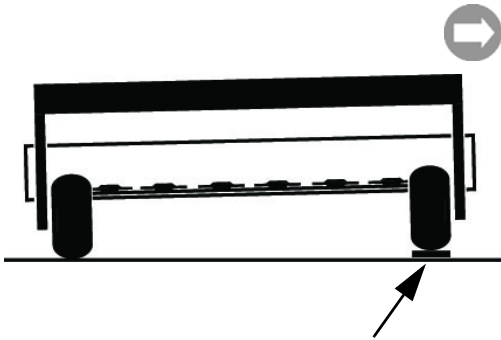

- ▶ Place a wooden block or similar under the right-hand wheel of the machine so that the machine slants slightly to the left.



- ▶ Activate the tractor hydraulics and raise the machine's cutterbar fully.

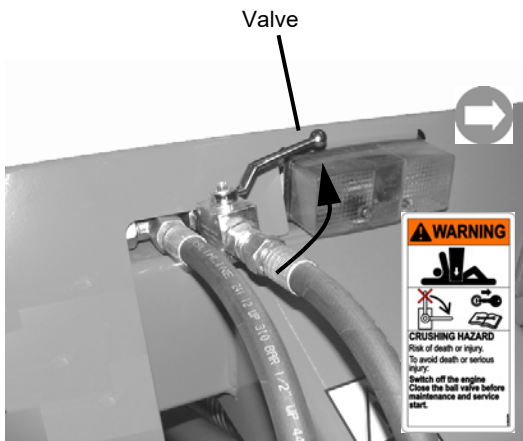

- ▶ Close the mechanical safety valve.
- ▶ Connect the tractor's P.T.O. shaft and allow the machine to run for about 5 minutes.
- ▶ Turn off the tractor's P.T.O. shaft
- ▶ Stop the tractor and remove the ignition key.

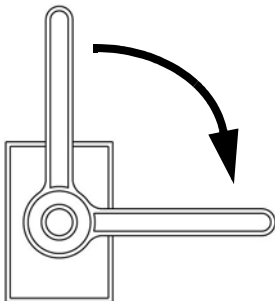

- ▶ Remove the linchpin.
- ▶ Open the front guard.
- ▶ Suspend the guard in the chain as shown.

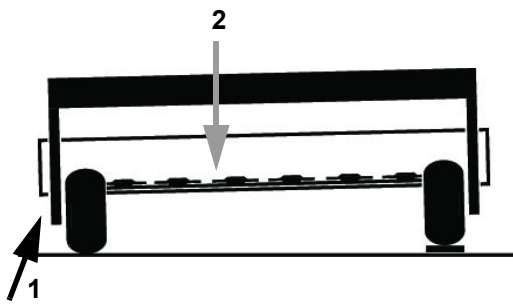
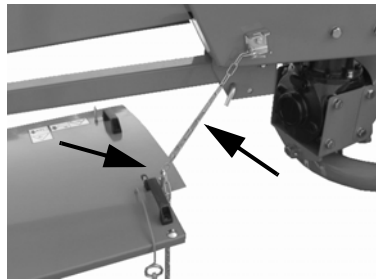
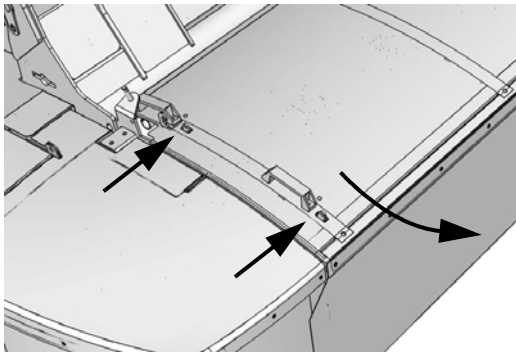

- ▶ Locate oil plugs 1 and 2 on the cutterbar and clean the area.
- ▶ Remove oil plug 1 and 2.
- ▶ Let the oil flow into a suitable container.
- ▶ Allow the last of the oil to drip out of the cutterbar for approx. 10 - 15 minutes.
- ▶ Insert oil plug [1].
- ▶ Fill with new oil.



- ▶ Always fill with the correct amount of oil.

Model	Liters	Pints (US)	Pints (Imp.)
8028	2.8	5.9	4.9
80-8532	3.2	6.8	5.6
80-8536	3.5	7.4	6.2
8540	4.0	8.5	7.0
8547	4.8	10.1	8.4

→ »Lubricants« Page 177

→ »Maintenance intervals« Page 112

- ▶ Insert oil plug [2].
- ▶ Close the front guard.
- ▶ Remove the linchpin.

Maintenance

- ▶ Open the mechanical safety valve.
- ▶ Adjust the tractor's lift arms to the height shown.

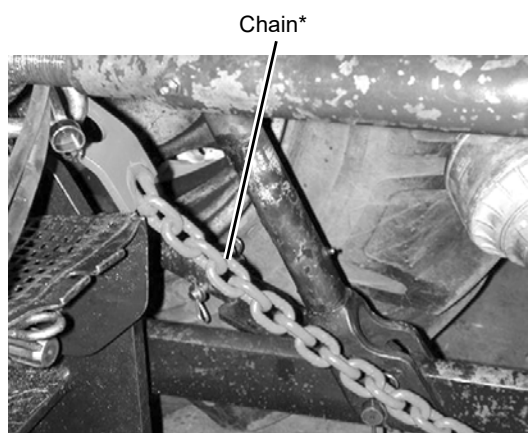
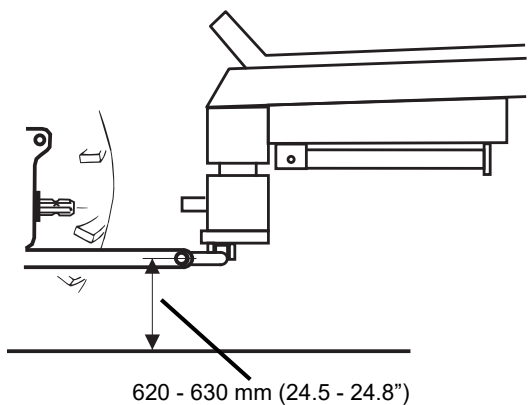

- ▶ Lock lift arms with a chain between the lifting arm and the highest point.

* Extra equipment
→ »Extra equipment« Page 164

Main gear

→ »Maintenance intervals« Page 112

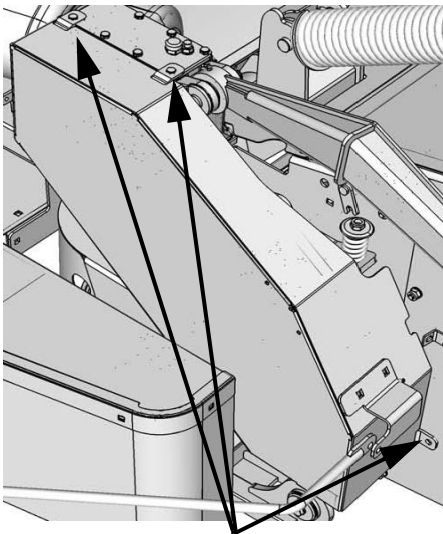

Bolt

All models

The oil is changed as follows:

- ▶ Remove the guard.
- ▶ Remove the oil plug.
- ▶ Let the oil flow into a suitable container.
- ▶ Allow the last of the oil to drip out of the transmission for approx. 10 - 15 minutes.
- ▶ Plug the oil plug back in place.

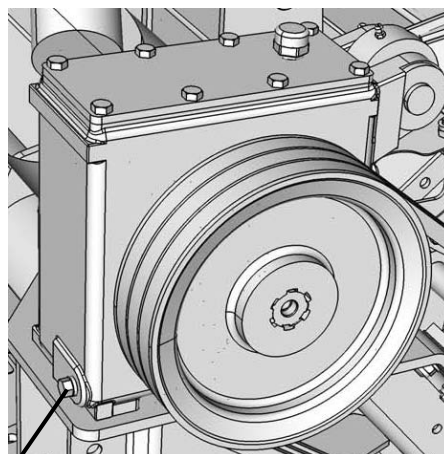
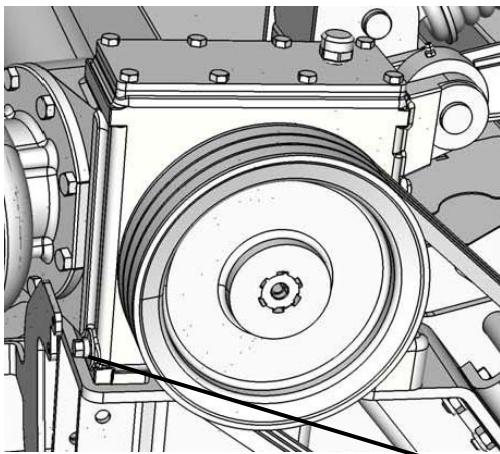

Oil plug

Maintenance

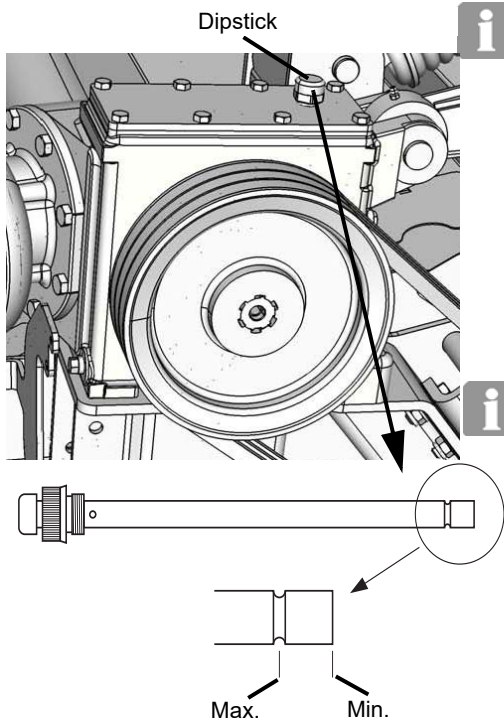

Always fill with the correct amount of oil.

Liters	Pints (US)	Pints (Imp.)
1.5	3.2	2.6



- ▶ Remove the dipstick.
- ▶ Pour the new oil through the hole where the dipstick is fitted.
- ▶ Put the dipstick into the transmission, then remove it again.
- ▶ Check that the oil level is up to the “max” indication on the dipstick.
- ▶ Repeat the procedure until the correct oil level is reached.

The oil level on the main gear must always be between “min.” and “max.” as shown on the dipstick.

→ »Lubricants« Page 177

- ▶ Affix the protection.

Center gear

85xxT-R mode only

→ »Maintenance intervals« Page 112

The oil is changed as follows:

- ▶ Remove oil plug 3.
- ▶ Let the oil flow into a suitable container.
- ▶ Allow the last of the oil to drip out of the transmission for approx. 10 - 15 minutes.
- ▶ Insert oil plug 3.

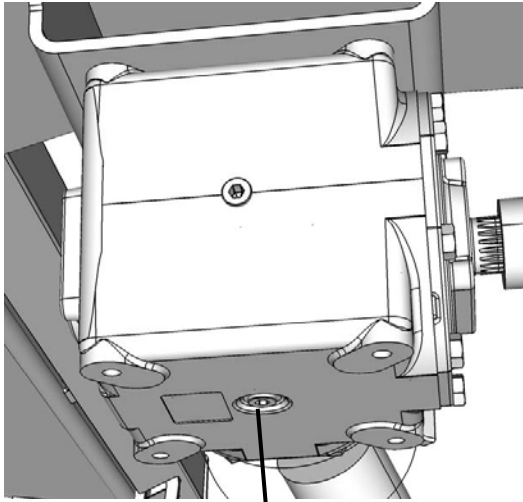

Oil plug 3



Always fill with the correct amount of oil.

Liters	Pints (US)	Pints (Imp.)
2.3	4.9	4.0

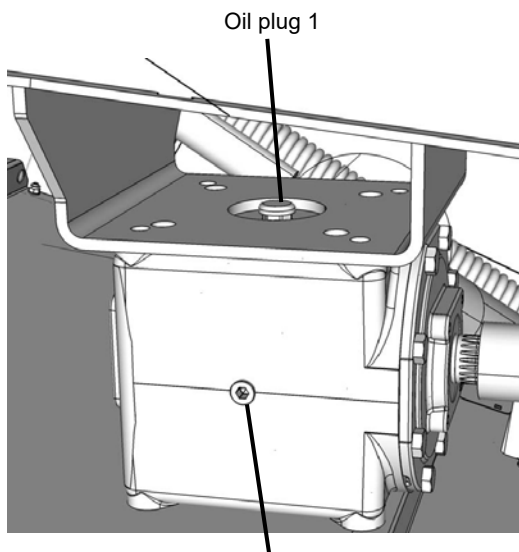

Oil plug 1

Oil plug 2

- ▶ Remove oil plug 1 and 2.
- ▶ Fill the new oil through the hole for oil plug 1.
- The correct oil level is reached when the oil reaches the edge of the hole for oil plug 2.
- ▶ Fit oil plug 1 and 2.

→ »Lubricants« Page 177

Maintenance

Swivel gear

The upper part of the swivel hitch

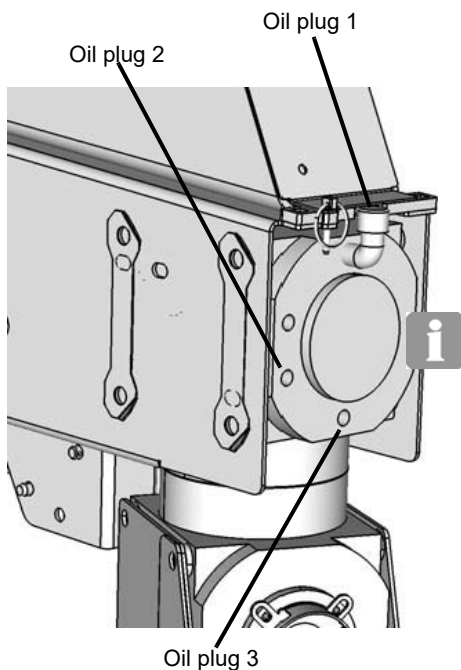

→ »Maintenance intervals« Page 112

The oil is changed as follows:

- ▶ Remove oil plug 3.
- ▶ Let the oil flow into a suitable container.
- ▶ Allow the last of the oil to drip out of the transmission for approx. 10 - 15 minutes.
- ▶ Insert oil plug 3.
- ▶ Remove oil plug 1 and 2.
- ▶ Fill the new oil through the hole for oil plug 1.

Always fill with the correct amount of oil.

Liters	Pints (US)	Pints (Imp.)
1.3	2.7	2.3

- The correct oil level is reached when the oil reaches the edge of the hole for oil plug 2.
- ▶ Fit oil plug 1 and 2.

→ »Lubricants« Page 177

The lower part of the swivel hitch

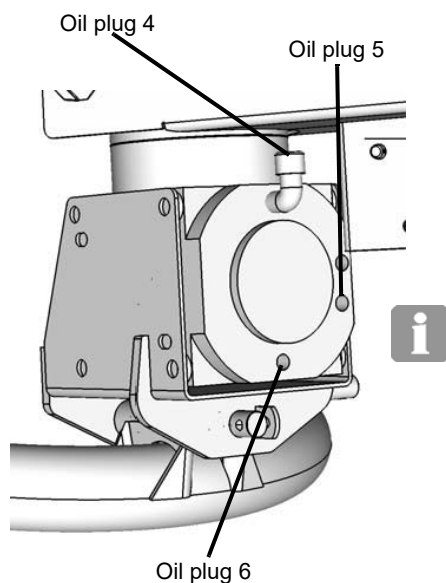

→ »Maintenance intervals« Page 112

The oil is changed as follows:

- ▶ Remove oil plug 6.
- ▶ Let the oil flow into a suitable container.
- ▶ Allow the last of the oil to drip out of the transmission for approx. 10 - 15 minutes.
- ▶ Insert oil plug 6.
- ▶ Remove oil plug 4 and 5.
- ▶ Fill the new oil through the hole for oil plug 5.
- ▶ Always fill with the correct amount of oil.

Liters	Pints (US)	Pints (Imp.)
1.8	3.8	3.2

- The correct oil level is reached when the oil reaches the edge of the hole for oil plug 5.
- ▶ Insert oil plug 4

→ »Lubricants« Page 177

Rollers

Only R model Main gear

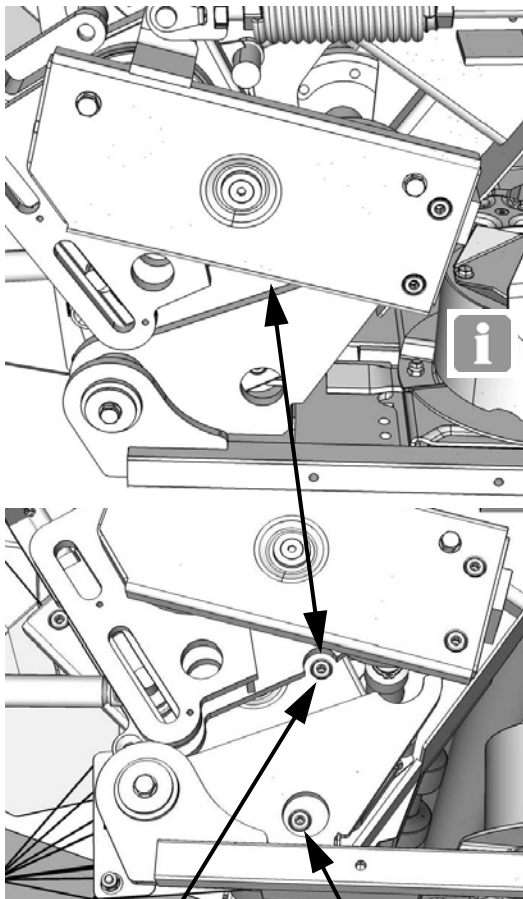

Oil plug 1

Oil plug 2

Oil is changed as follows:

- ▶ Remove oil plug 2.
- ▶ Let the oil flow into a suitable container.
- ▶ Allow the last of the oil to drip out of the cutterbar for approx. 10 - 15 minutes.
- ▶ Fit and tighten the oilplug 2.
- ▶ Remove oil plug 1.
- ▶ Fill the oil through the hole for oil plug 1.

Always fill with the correct amount of oil.

Liters	Pints (US)	Pints (Imp.)
0.8	1.7	1.4

- The correct oil level is reached when the oil reaches the edge of the hole for oil plug 1.
- ▶ Fit and tighten the oilplug 1.
- »Lubricants« Page 177
- »Maintenance intervals« Page 112

Maintenance

Arm

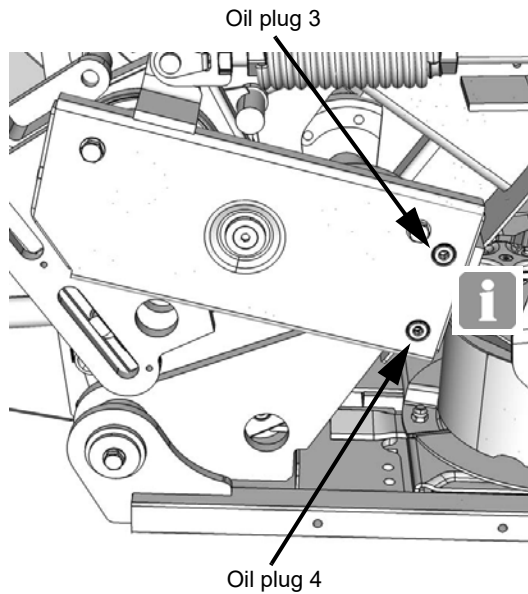

Oil is changed as follows:

- ▶ Remove oil plug 4.
- ▶ Let the oil flow into a suitable container.
- ▶ Allow the last of the oil to drip out of the cutterbar for approx. 10 - 15 minutes.
- ▶ Fit and tighten the oilplug 4.
- ▶ Remove oil plug 3.
- ▶ Fill oil through the hole for oil plug 3.

Always fill with the correct amount of oil.

Liters	Pints (US)	Pints (Imp.)
0.75	1.6	1.3

- The correct oil level is reached when the oil reaches the edge of the hole for oil plug 3.

→ »Lubricants« Page 177

→ »Maintenance intervals« Page 112

Cone

Internal inspection

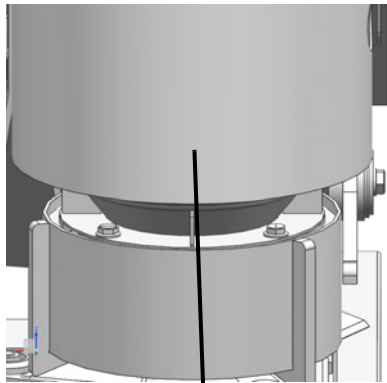

Guard

→ »Maintenance intervals« Page 112

An internal check of the cones is carried out in the following way:

- ▶ Dismantle the protection around the cutterbar's transmission.

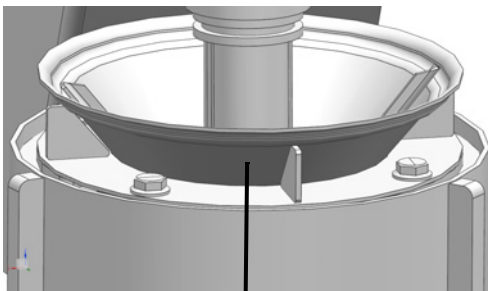

Top cover

- ▶ Remove the top cover from the cone.
- ▶ Clean the inside of the cone.
- ▶ Fit the top cover on the cone.
- ▶ Fit the guard around the cutterbar's transmission.

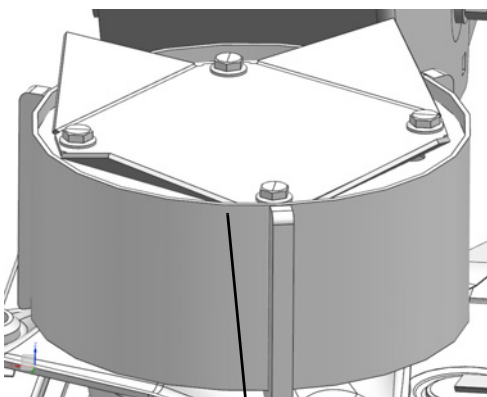

Top cover

- ▶ Remove the top cover on the cones that are found on the opposite side of the transmission.
- ▶ Clean the inside of the cone.
- ▶ Fit the top cover on the cone.

Maintenance

Drive shaft

→ »Maintenance intervals« Page 112

The drive shaft between the transmission and the cutterbar is checked in the following way:

- ▶ Dismount the protection around the P.T.O. shaft between the transmission and the cutterbar.

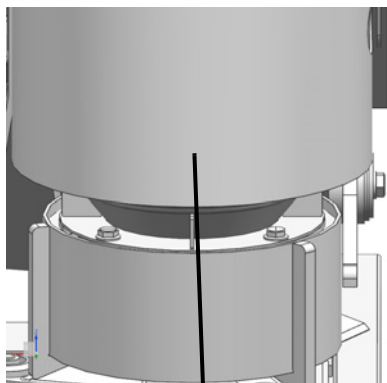

Guard

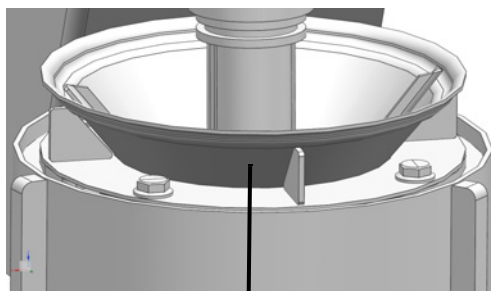

Top cover

- ▶ Remove the top cover from the cone.

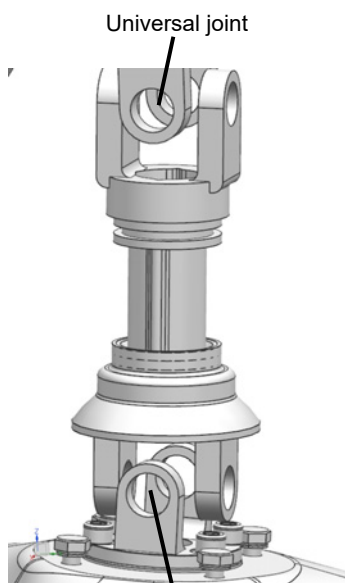

Universal joint

- ▶ Inspect both universal joints for wear.

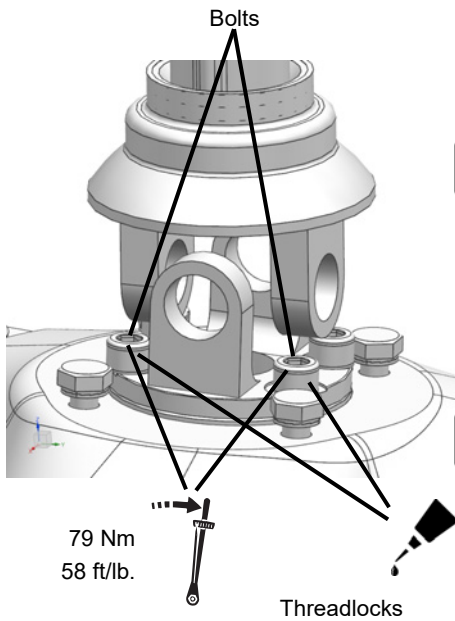

- ▶ Check for broken or loose bolts.
- ▶ Replace the broken bolts.
- ▶ Apply thread locking of a recognized brand on bolts.
 - ▶ Follow the instructions for the application of threadlocks.



Threadlocks shall be of the high strength (high viscosity) type.

- ▶ Affix the bolts and tighten to the indicated torque.

If there are loose bolts, the following procedure should be followed:

- ▶ Remove and clean the bolts.
- ▶ Apply thread locking of a recognized brand on bolts.
 - ▶ Follow the instructions for the application of threadlocks.



Threadlocks shall be of the high strength (high viscosity) type.

- ▶ Affix the bolts and tighten to the indicated torque.

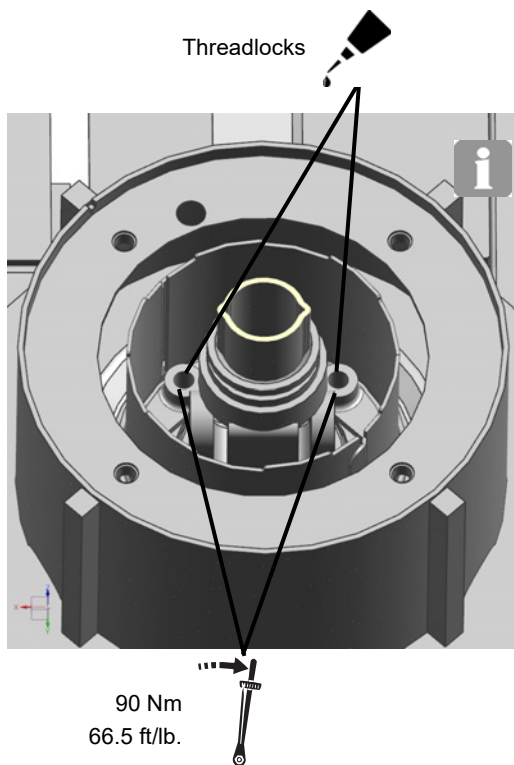

If the cone has been dismantled:

- ▶ Clean all bolts to the cone.
- ▶ Apply thread locking of a recognized brand on bolts.
 - ▶ Follow the instructions for the application of threadlocks.



Threadlocks shall be of the high strength (high viscosity) type.

- ▶ Attach the cone using the indicated tightening torque.

Maintenance

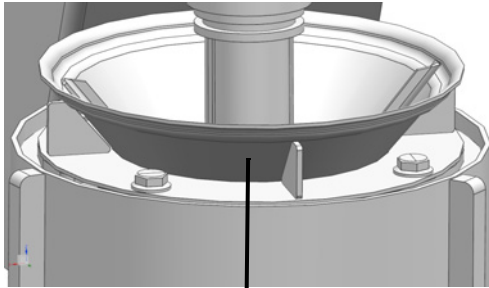

Top cover

- ▶ Fit the top cover on the cone.

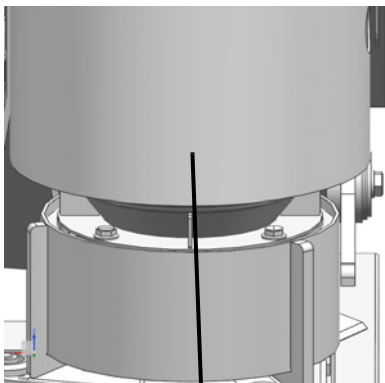

Guard

- ▶ Fit the guard around the cutterbar's transmission.

Bolts on transmission

85xxT-R mode only

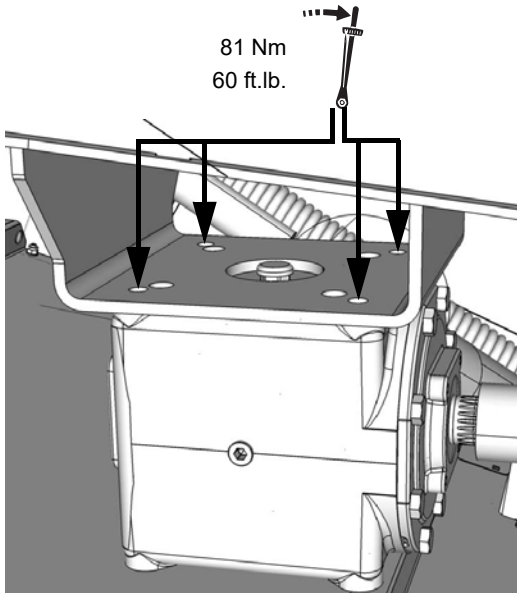

→ »Maintenance intervals« Page 112

- ▶ Use a torque wrench and set it to the indicated torque.
- ▶ Check all the bolts on the transmission.

If bolts are loose:

- ▶ Tighten the bolt to the indicated torque.

Maintenance

Lubrication

Drive shaft

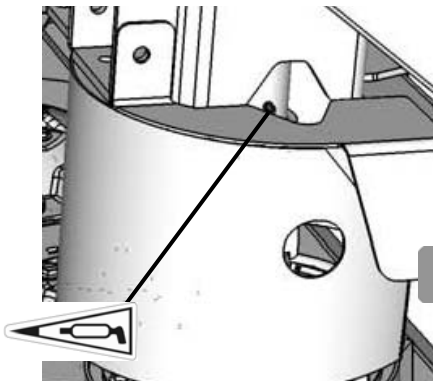

- ▶ Turn the cutting disc until both grease nipples are visible
 - ▶ Press the nozzle of the grease gun over the grease nipples.
 - ▶ Pump the grease gun once (1 x) or twice (2 x) (max.).
- »Maintenance intervals« Page 112
→ »Lubricants« Page 177

i Watch out for blades and sharp edges.

Bearings

- ▶ Locate the grease nipples on both sides of the machine.
 - ▶ Press the nozzle of the grease gun over the grease nipples.
 - ▶ Pump the grease gun once (1 x) or twice (2 x) (max.).
- »Maintenance intervals« Page 112
→ »Lubricants« Page 177

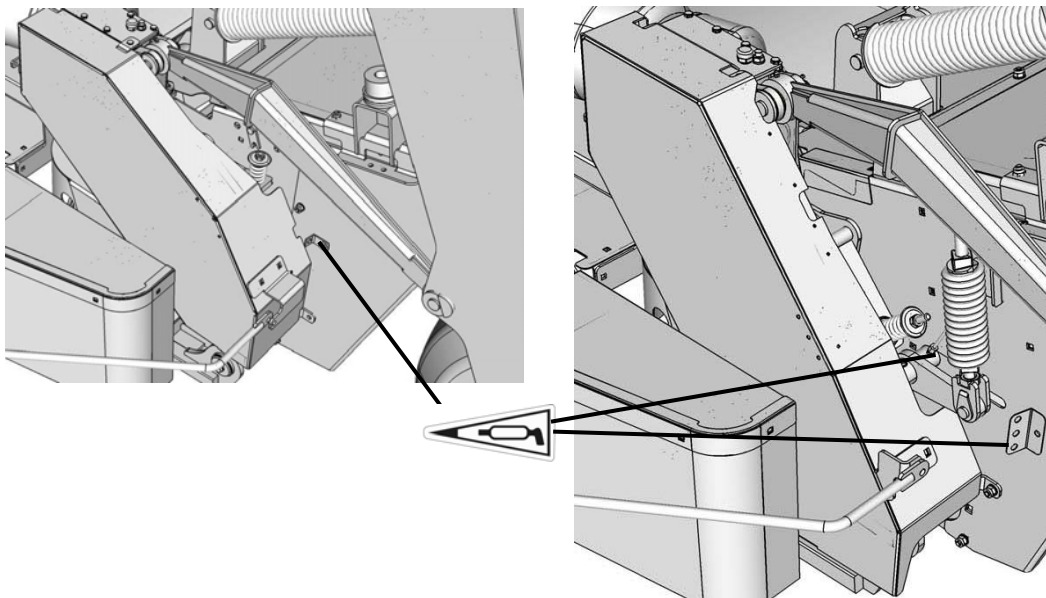

Moving joints

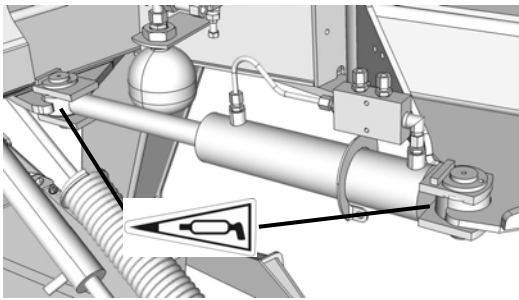

- ▶ Press the nozzle of the grease gun over the grease nipples.
- ▶ Pump the grease gun once (1 x) or twice (2 x) (max.).
- »Maintenance intervals« Page 112
- »Lubricants« Page 177

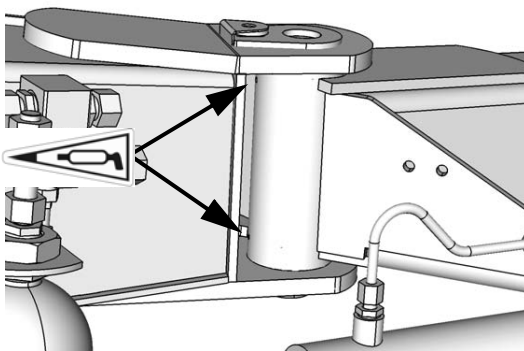

- ▶ Press the nozzle of the grease gun over the grease nipple.
- ▶ Pump the grease gun once (1 x) or twice (2 x) (max.).
- »Maintenance intervals« Page 112
- »Lubricants« Page 177

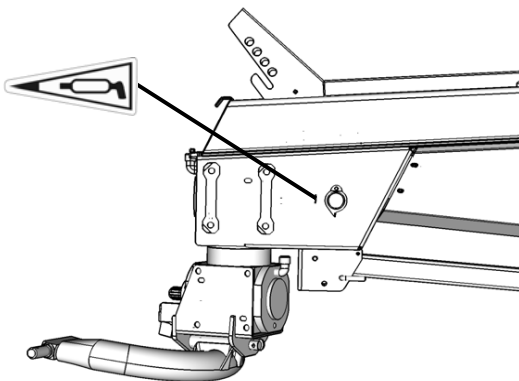

- ▶ Open the cover.
- ▶ Press the nozzle of the grease gun over the grease nipple.
- ▶ Pump the grease gun once (1 x) or twice (2 x) (max.).
- »Maintenance intervals« Page 112
- »Lubricants« Page 177
- ▶ Close the cover.

Maintenance

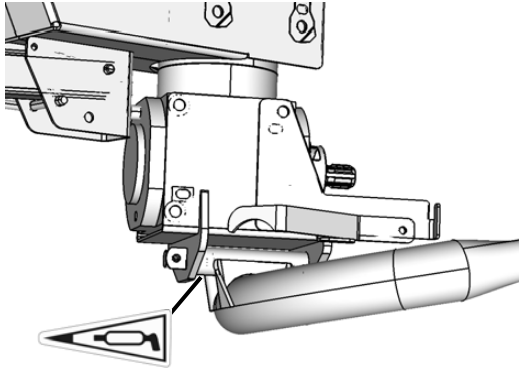

- ▶ Press the nozzle of the grease gun over the grease nipple.
- ▶ Pump the grease gun once (1 x) or twice (2 x) (max.).
- »Maintenance intervals« Page 112
- »Lubricants« Page 177

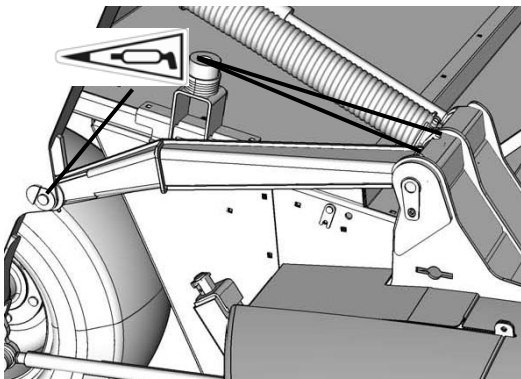

- ▶ Press the nozzle of the grease gun over the grease nipple.
- ▶ Pump the grease gun once (1 x) or twice (2 x) (max.).
- »Maintenance intervals« Page 112
- »Lubricants« Page 177

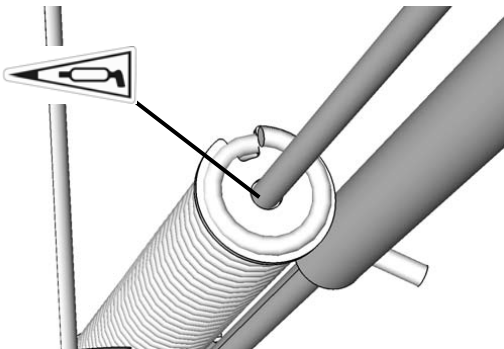

- ▶ Press the nozzle of the grease gun over the grease nipple.
- ▶ Pump the grease gun once (1 x) or twice (2 x) (max.).
- »Maintenance intervals« Page 112
- »Lubricants« Page 177

As required

WARNING

Safety in connection with maintenance work on the machine

When working on the machine the tractor must be stopped and secured. This prevents the PTO shaft from suddenly starting to rotate. Failure to follow the safety instructions may result in serious injuries.

When working on the machine:

- The P.T.O. is disengaged.
- Lower the implement to the ground.
- The tractor engine must be stopped.
- The ignition key is removed.
- The parking brake is set.
- Secure the tractor to prevent it from rolling.



Failure to secure the tractor to prevent it from rolling could endanger lives.

Always use original spare parts on the machine

Always use original spare parts. Original spare parts should be used for safety reasons. The manufacturer's warranty becomes void if non-original spare parts are used.

Make sure that all protective guards are in place

Check that all protection guards are in place. This ensures that the machine will offer maximum protection to the operator from the cutting blades. If the safety guards are removed or not used it may result in serious injuries and accidents.

Maintenance

Blades

WARNING

Check the machine blades on a regular basis

The machine's blades must be regularly inspected. Worn or damaged blades can unbalance the rotating parts. Vibrations can cause damage to the machine.

→ »Maintenance intervals« Page 112

The blades are replaced as follows:

- ▶ Activate the tractor hydraulics and raise the machine's cutterbar fully.



- ▶ Close the mechanical safety valve.

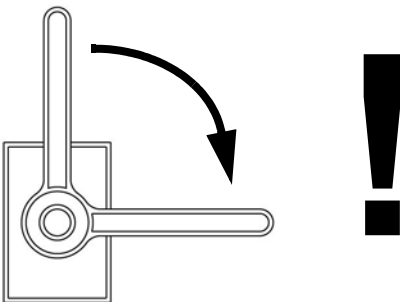
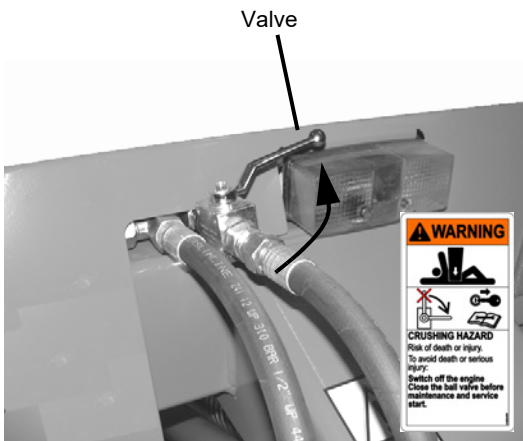

- ▶ Remove the linchpin.
- ▶ Open the front guard.
- ▶ Suspend the guard in the chain as shown.

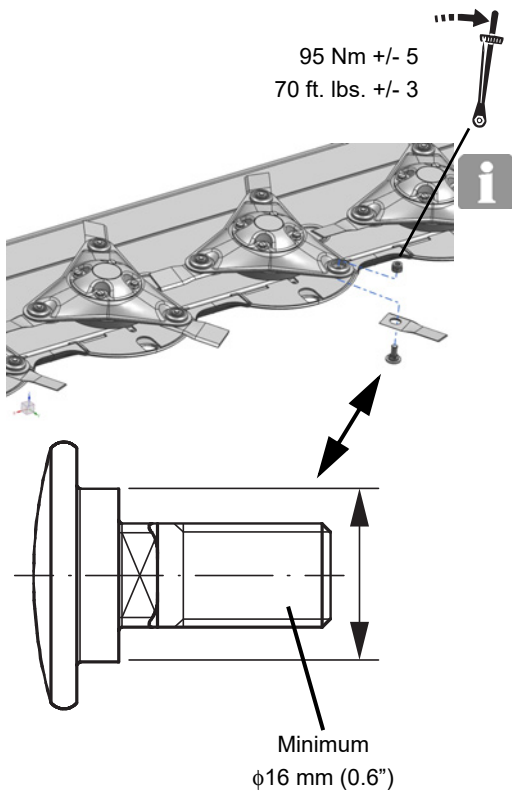
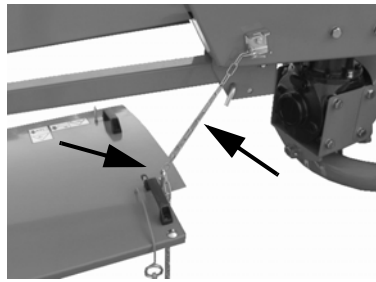
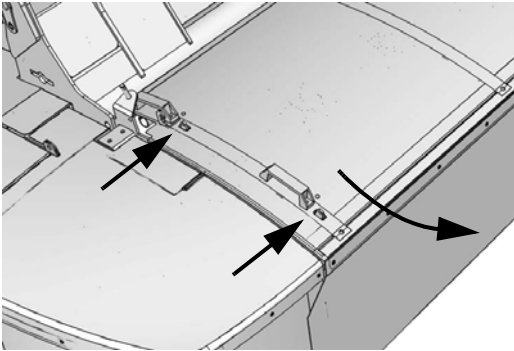

- ▶ Turn the cutting discs by hand until the damaged blade is in the position shown.
- ▶ Remove the bolt.

The minimum diameter of the bolt must not be less than $\phi 16$ mm (0.6").

- ▶ Replace the blade and affix the bolt.
- ▶ Use a torque wrench to tighten the bolt to the torque shown.

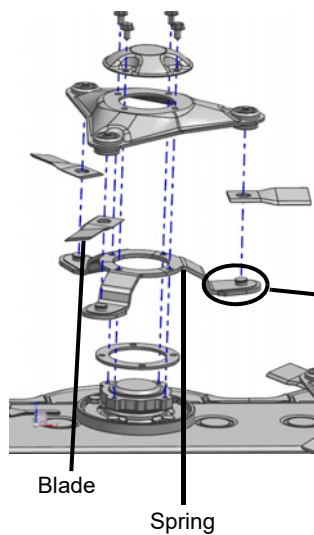

i If the machine is equipped with quick-changing blades*, the same requirements apply as for the wear and tear of bolts.
→ »Blades« Page 117

* Extra equipment
→ »EXPRESS« Page 166

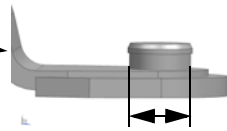

Min. ϕ 16 mm (0.6")

- ▶ Close the front guard.
- ▶ Remove the linchpin.
- ▶ Open the mechanical safety valve.

Cutting disc

→ »Maintenance intervals« Page 112

The cutting discs are replaced as follows:

- ▶ Activate the tractor hydraulics and raise the machine's cutterbar fully.

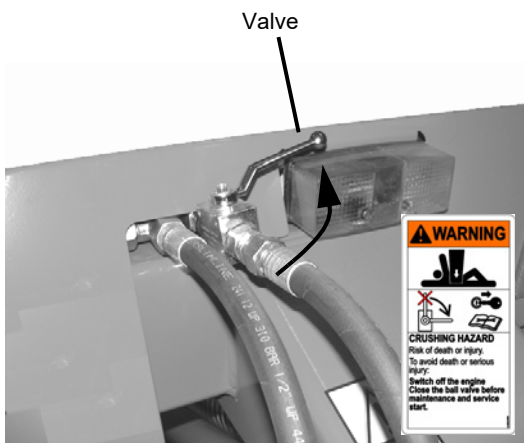

- ▶ Close the mechanical safety valve.

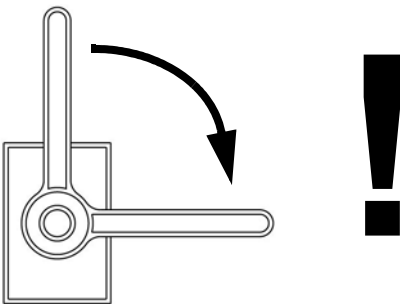

- ▶ Remove the linchpin.
- ▶ Open the front guard.
- ▶ Suspend the guard in the chain as shown.

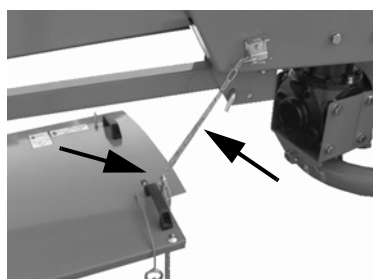
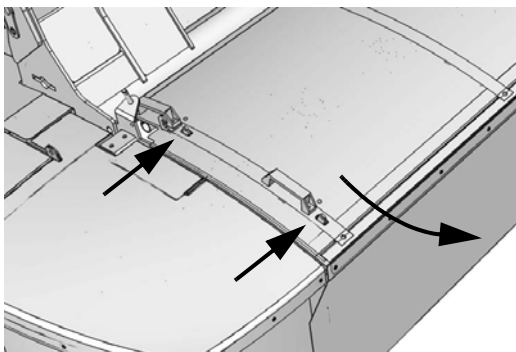

Maintenance

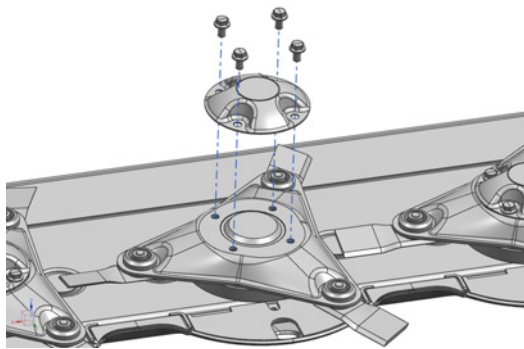

- ▶ Dismantle the cutting disc.

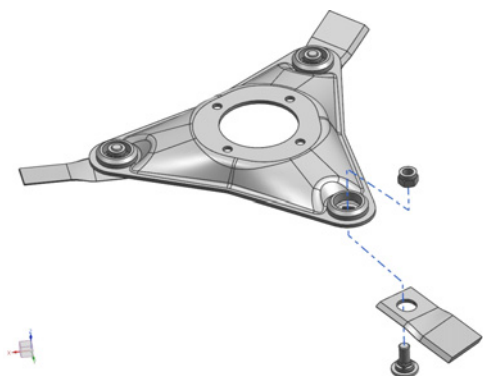

- ▶ Remove the bolt and blade from the cutting disc.

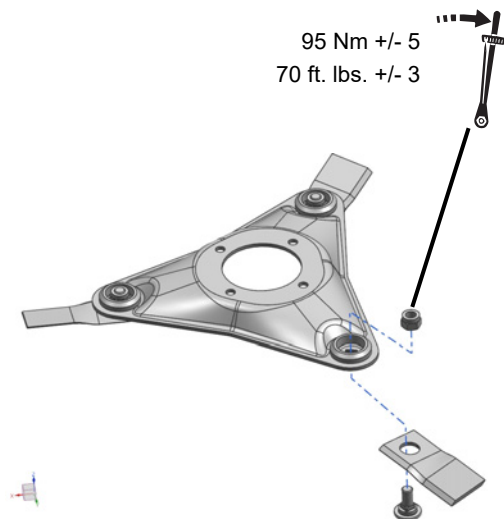

- ▶ Affix the blade and bolt on the new cutting disc.
- ▶ Use a torque wrench to tighten the nut to the torque shown.

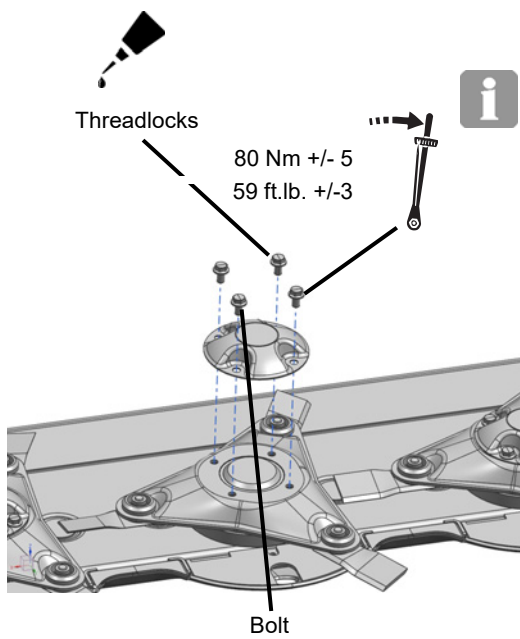

- ▶ Apply thread locking of a recognized brand on all bolts.
 - ▶ Follow the instructions for the application of threadlocks.
- ▶ Threadlocks shall be of the high strength (high viscosity) type.
- ▶ Affix the cutting disc on the cutterbar.
- ▶ Use a torque wrench to tighten the bolt to the torque shown.
- ▶ Close the front guard.
- ▶ Remove the linchpin.
- ▶ Open the mechanical safety valve.
- ▶ Activate the tractor hydraulics and lower the cutting unit of the machine.

Maintenance

Stone guard and counter blade

WARNING

Proper support for the machine is vitally important

When working under the machine, the machine must be properly supported. If the machine is not properly supported, there is a great danger that the machine will tip over onto people. Insufficient support of the machine may result in serious injuries and death.

→ »Maintenance intervals« Page 112

The stone guard and counter blade are changed as follows:

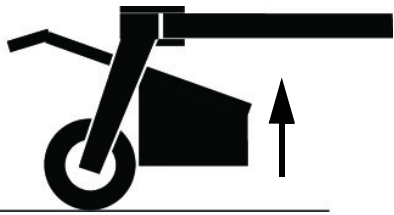

- ▶ Activate the tractor hydraulics and raise the machine to its fullest extent.

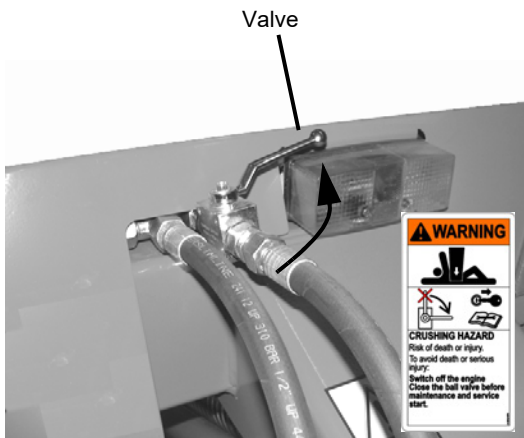

- ▶ Close the mechanical safety valve.

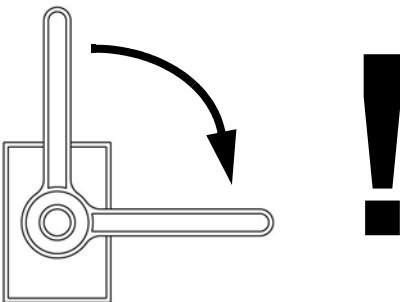

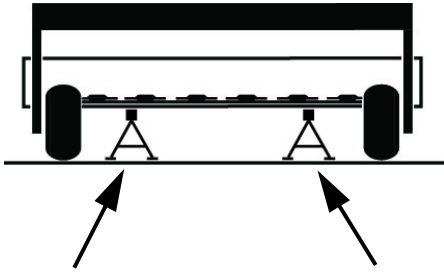

- ▶ Place a suitable support under the machine's cutting unit.
- It is important that the machine is correctly secured with a sturdy support before work is started.

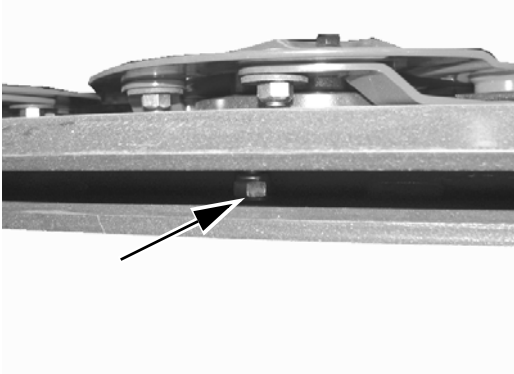

- ▶ Remove the worn stone guard and counter blade.

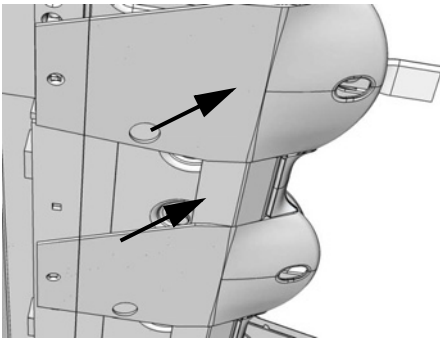

- ▶ Fit the new stone guard and counter blade.
- Stone guards and counter blades with visible holes caused by heavy wear must be replaced immediately.
- ▶ Remove the support.
 - ▶ Open the mechanical safety valve.
 - ▶ Activate the tractor hydraulics and lower the cutting unit of the machine.

Maintenance

Y-fingers

Only T model

→ »Maintenance intervals« Page 112

The machine's Y-fingers are replaced as follows:

- ▶ Remove the nut on the bolt.
- ▶ Remove the bolt and the lock plate and replace the damaged Y-finger.

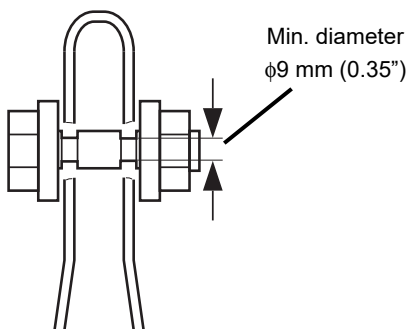
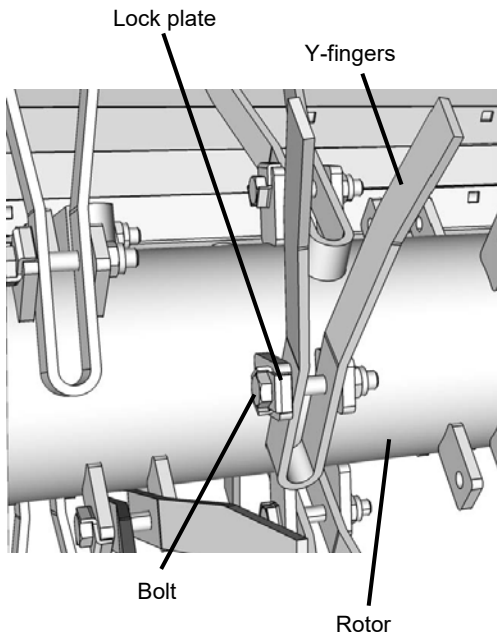

- ▶ Inspect the bolt for wear.

i The minimum diameter of the bolt must not be less than $\phi 9$ mm (0.35"). If the diameter of the bolt is less than $\phi 9$ mm (0.35") in the worn areas, it must be replaced.

- ▶ Fit the bolt with the lock plate and Y-fingers.
- ▶ Tighten the bolt.

i The Y-fingers should be able to move freely.

V-belt

V-belts for the rotor transmission must be replaced when it is shown that they are worn.

→ »Maintenance intervals« Page 112

The V-belts are changed in the following way:

- ▶ Remove the guard.

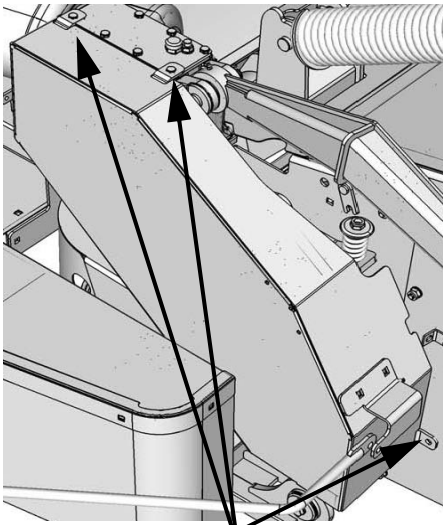

Bolt

- ▶ Remove the nut and the spring completely.
- ▶ Remove the V-belts.
- ▶ Put the new V-belts in place.

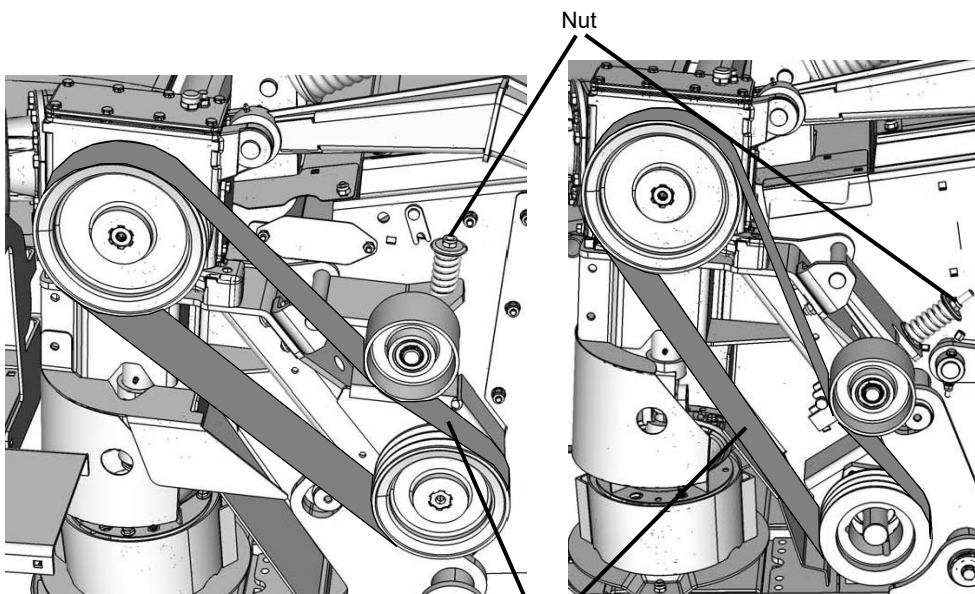

Nut

V-belt

Maintenance

► Tighten the springs to the measurement shown.

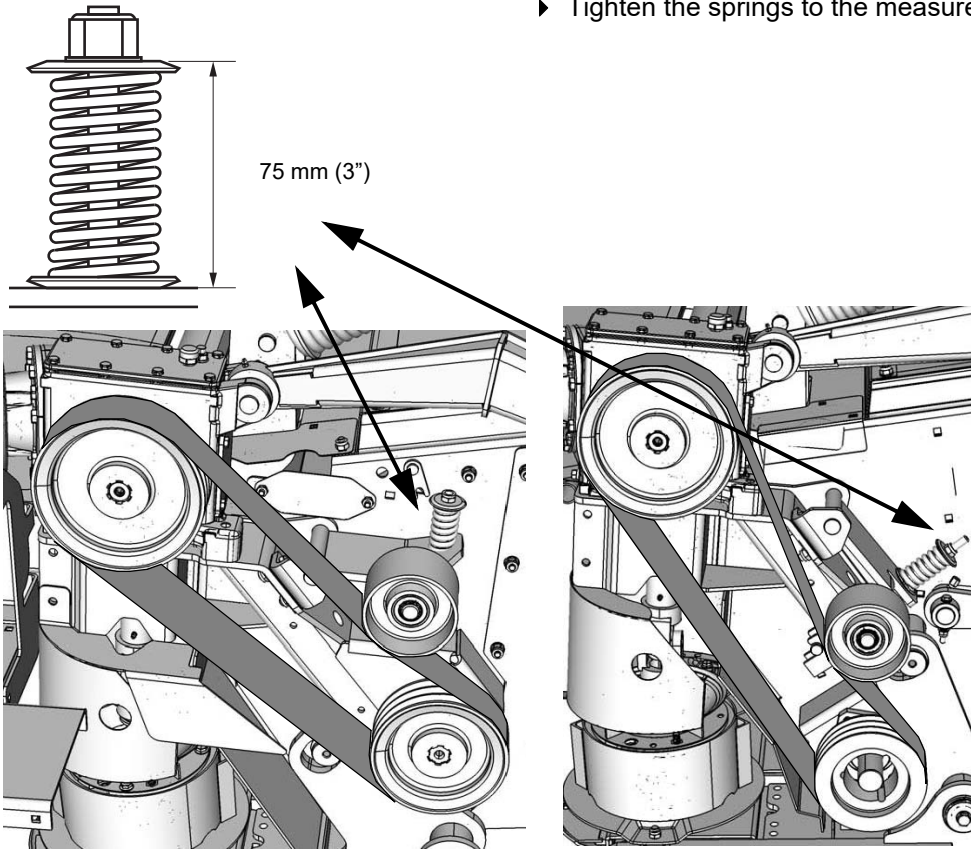

► Affix the protection.

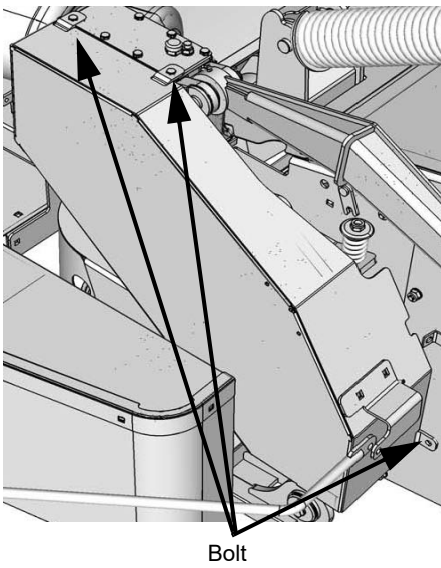

Drive shaft

→ »Maintenance intervals« Page 112

The drive shaft is replaced as follows:

- ▶ Activate the tractor hydraulics and raise the machine's cutterbar fully.

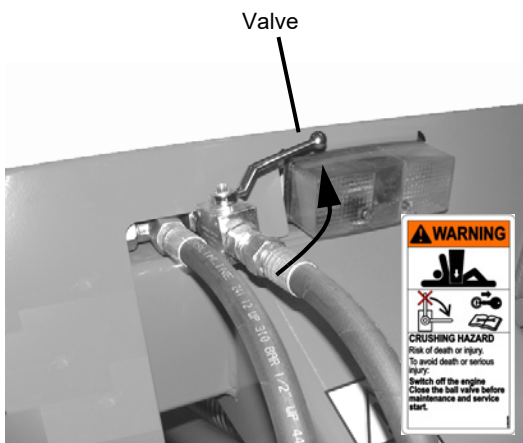

- ▶ Close the mechanical safety valve.

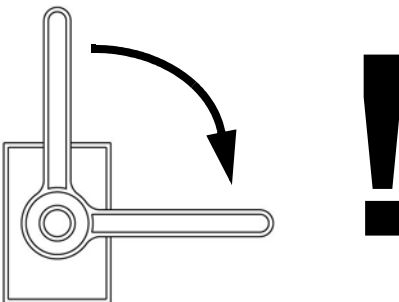

- ▶ Remove the linchpin.
- ▶ Open the front guard.
- ▶ Suspend the guard in the chain as shown.

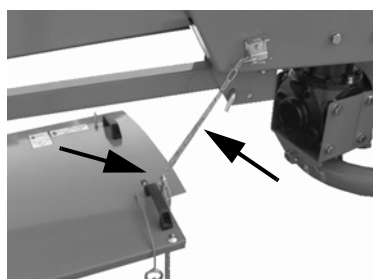
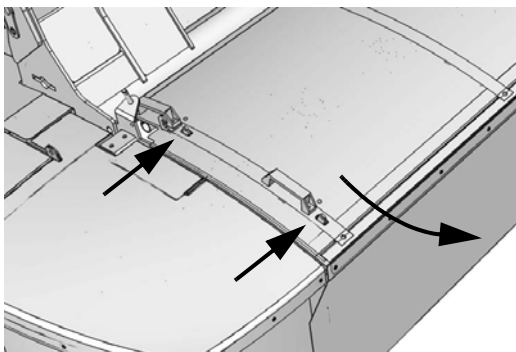

Maintenance

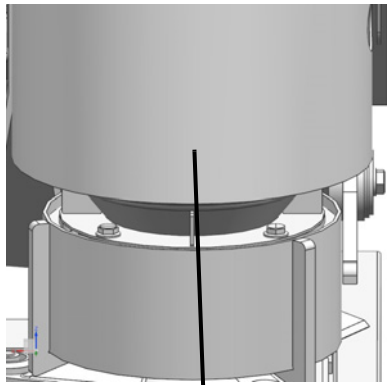

Guard

- ▶ Dismount the protection around the drive shaft between the transmission and the cutterbar.

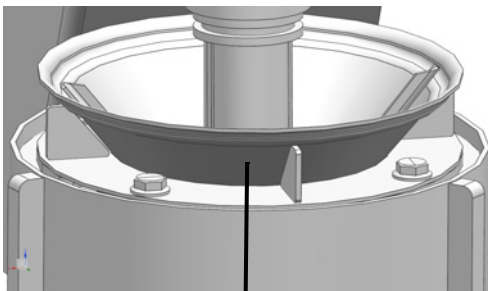

Top cover

- ▶ Remove the top cover from the cone.

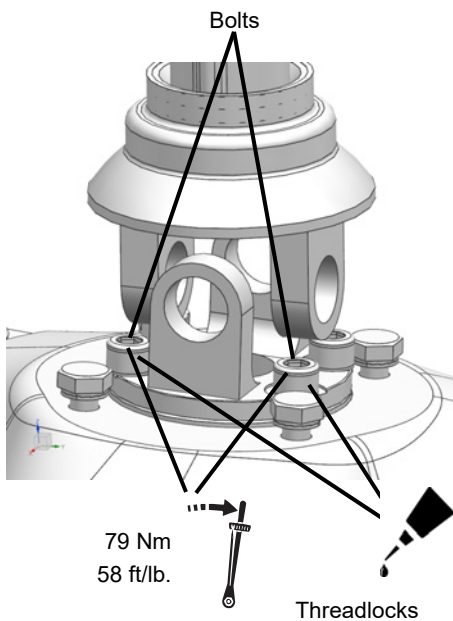

79 Nm
58 ft/lb.

Threadlocks

- ▶ Remove the bolt and replace the drive shaft.
 - ▶ Clean the bolts.
 - ▶ Apply thread locking of a recognized brand on bolts.
 - ▶ Follow the instructions for the application of threadlocks.
- i** Threadlocks shall be of the high strength (high viscosity) type.
- ▶ Affix the bolts and tighten to the indicated torque.

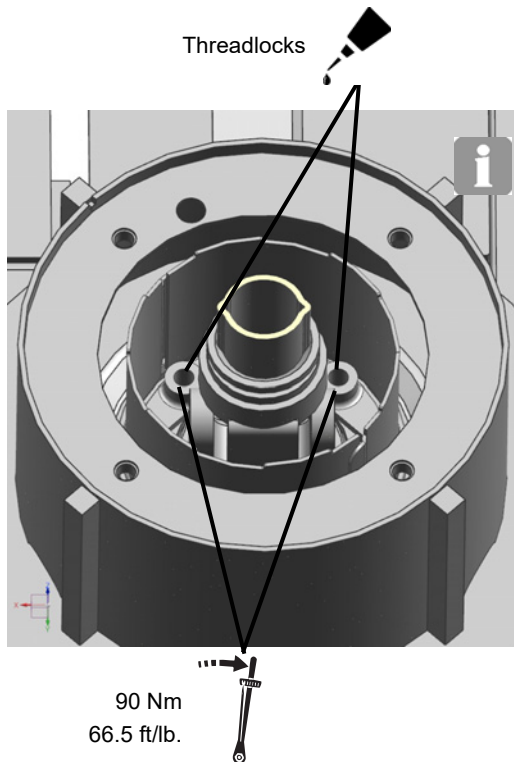

If the cone has been dismantled:

- ▶ Clean all bolts to the cone.
- ▶ Apply thread locking of a recognized brand on bolts.
 - ▶ Follow the instructions for the application of threadlocks.

Threadlocks shall be of the high strength (high viscosity) type.

- ▶ Attach the cone using the indicated tightening torque.

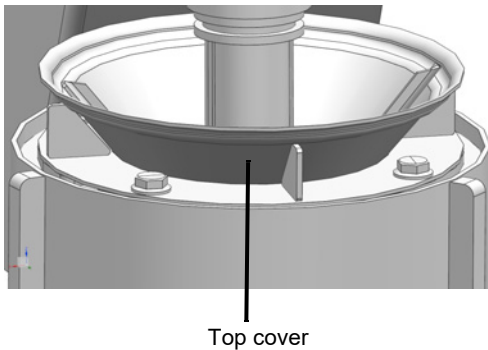

- ▶ Fit the top cover on the cone.

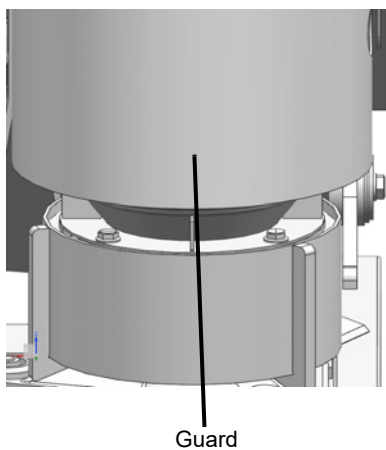

- ▶ Fit the guard around the cutterbar's transmission.
- ▶ Close the front guard.
- ▶ Remove the linchpin.
- ▶ Open the mechanical safety valve.
- ▶ Activate the tractor hydraulics and lower the cutting unit of the machine.

Maintenance

Tarpaulin

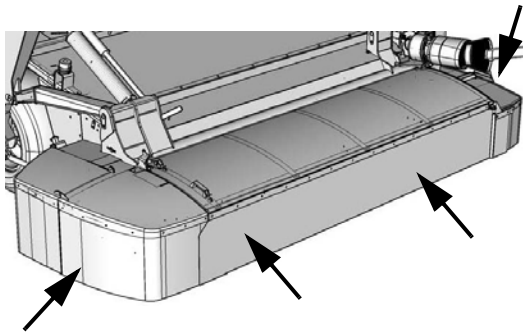

Replacement of a damaged tarpaulin and auxiliary protection is done as follows:

- ▶ Remove the machine's protection.
- ▶ Replace the damages parts.
- ▶ Attach the machine's protection.
- ▶ Make sure that the machine's protection is correctly attached.

Wheel

→ »Maintenance intervals« Page 112

Upon a worn tire or a puncture, the wheel on the machine must be replaced.

A wheel is replaced as follows:

- ▶ Position a jack at the machine's wheel as shown.
- Minimum lifting capacity: 2000 kg (4410 lb).
- ▶ Lift the wheel free from the ground.
- ▶ Remove all bolts from the wheel.
- ▶ Replace the wheel.

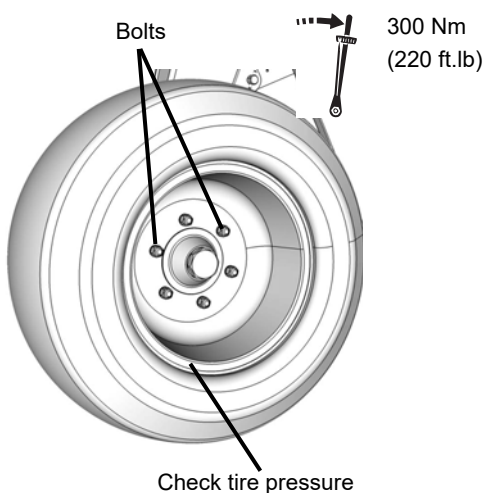
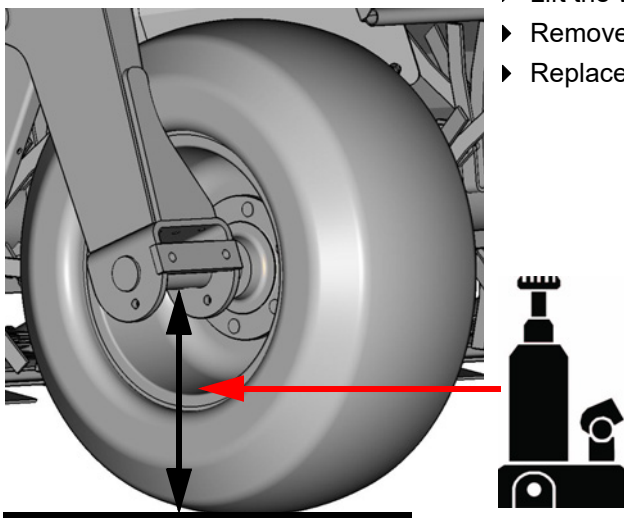

- ▶ Place and tightening all bolts on the wheel to the indicated torque.
- ▶ Check the tire pressure, refill the tire if necessary to the correct tire pressure.

→ »Specifications« Page 37

P.T.O. shaft



Refer to the manufacturer's user manual included with the P.T.O. shaft.

→ »User manual for the P.T.O. shaft« Page 43

→ »Lubricants« Page 177



Friction clutch

With respect to replacing the friction discs on the P.T.O. shaft, refer to the included user's manual.

→ »User manual for the P.T.O. shaft« Page 43

Accumulator



WARNING

Very high amount of accumulated pressure in the accumulator

Do not attempt to replace the accumulator. The accumulator contains a very high level of accumulated pressure and may only be taken apart by authorized persons. Attempting to replace the accumulator can lead to serious or fatal injury.

Accumulator

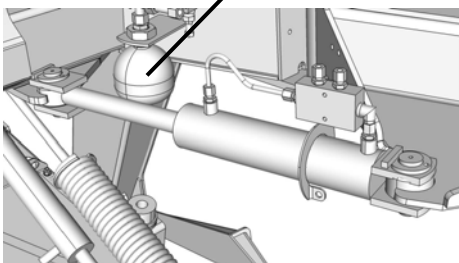

Accumulator pressure: 145 bar (2100 psi).



Inspections and/or repairs must only be done by authorized service staff.

Extra equipment

Bx-equipment

Does not apply to 8547



With this equipment, two swaths can be put combined into one. This saves time and increases the capacity for the subsequent cultivation of crop. The flexibility of this equipment also allows the user to switch between cutting with or without combining swaths during changeover.

Spreading device

Does not apply to 8547

The machine can be fitted with a flip-over spreading device that ensures a perfect spreading of the crop. The spreading device is simple to use and can be swung round when in use.



Skids

The machine can be fitted with high skids if a higher stubble height is required. High skids are recommended for uneven fields with lots of stones or molehills.

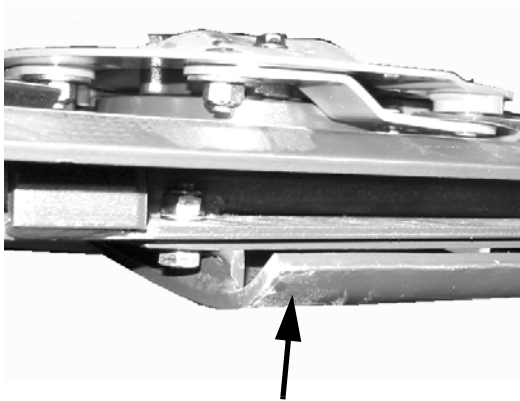

Stubble height	Setting - see chapter:	Page
20-45 mm (0.8 - 1.8")	»Short stubble height«	88
30-50 mm (1.2 - 2")	»Long stubble height«	90
35-85 mm (1.4 - 3.3")	»Long stubble height« + 20 mm (0.8") skids fitted	90
65-125 mm (2.6 - 5")	»Long stubble height« + 60 mm (2.4") skids fitted	90
85-150 mm (3.3 - 6")	»Long stubble height« + 80 mm (3.2") skids fitted	90

Stubble height

The machine can be fitted with a device allowing the stubble height of the machine to be seamlessly adjusted hydraulically from the tractor cab.

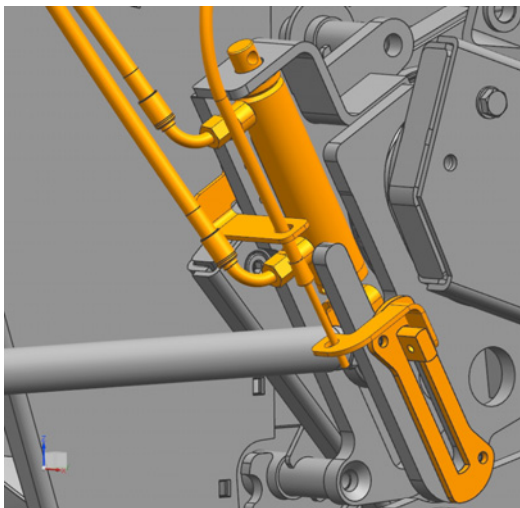

Extra equipment

EXPRESS

The machine can be equipped with a rapid blade changing system [EXPRESS], so that blades can easily be replaced or turned around in the course of a few seconds with the help of a simple tool.

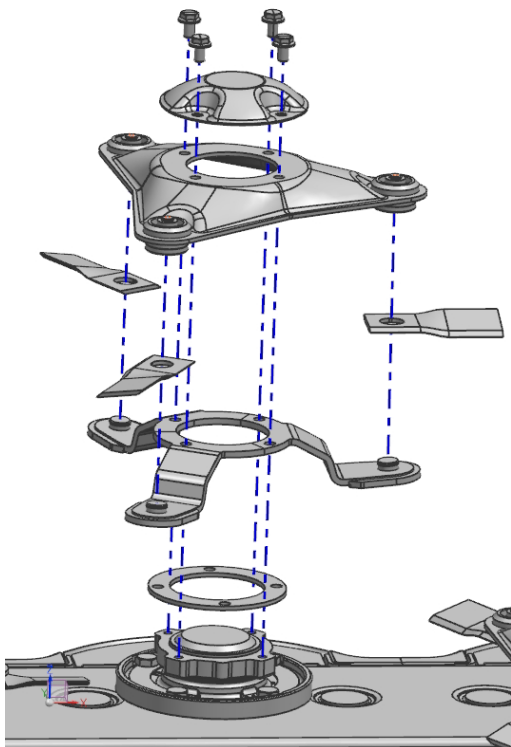

Throwing wings

Only T model

Fitting throwing wings is recommended to rectify any stripe problems with spring crops, caused by grass blocking the cutting discs.



The throwing wings are specifically made for right and left turning cutting discs.

Throwing wings

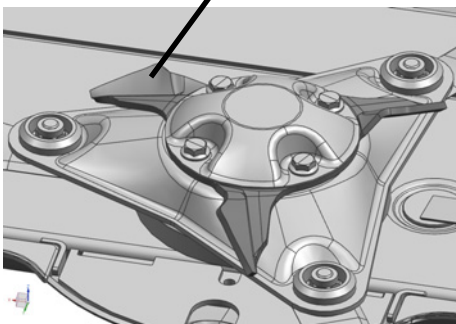

RPM of rotor

Only T model

500 RPM

For mowing whole crop

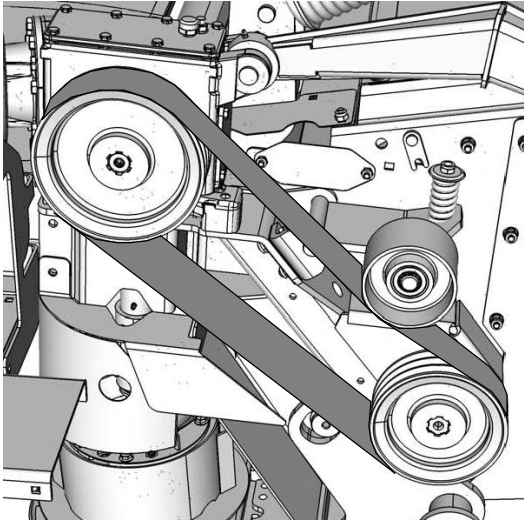

The machine can be fitted with a set consisting of a V-belt pulley and 3 V-belt parts, which reduces the speed of the machine's rotor to 500 RPM. It is recommended that this extra equipment be used for cutting whole crops.

→ »Rotor« Page 74

1015 RPM

for difficult crops and/or installed Bx-equipment*

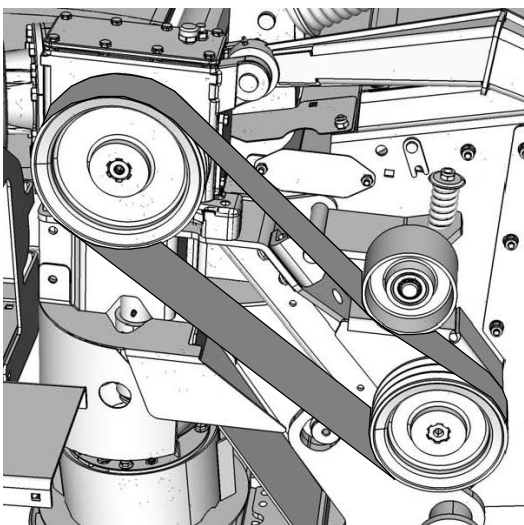

The machine can be fitted with a set consisting of a V-belt pulley and 3 V-belt parts, which changes the RPM of the machine rotor to 1015 RPM. It is recommended that this extra equipment be used when harvesting difficult crops and/or in combination with the attached Bx equipment on the machine.

→ »Rotor« Page 74

Extra equipment

900 RPM

The machine can be equipped with a kit consisting of a V-belt disc and 3 V-belts that maintain the RPM at the machine's rotor at 900 RPM, but can transfer more power to the rotor.



This extra equipment is only available on machines with working widths of 4 meters (13').

→ »Rotor« Page 74

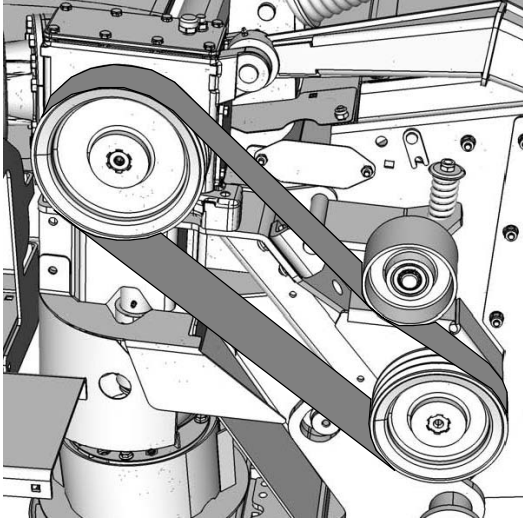

RPM of rollers

Only R model

750 RPM

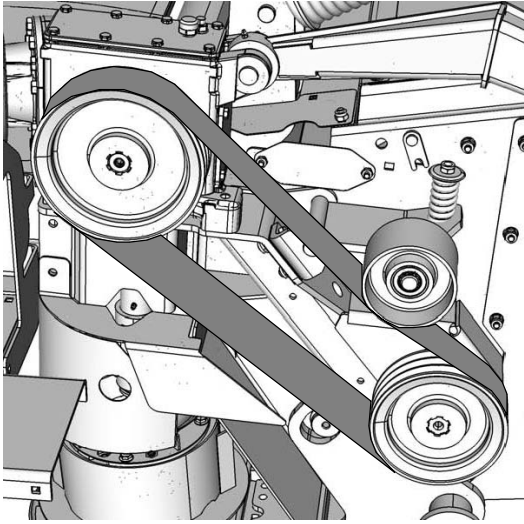

The machine may be equipped with a kit consisting of a V-belt pulley and three (3) V-belts which change the rotation of the machine rotors to 750 RPM.

→ »Rollers« Page 77

1200 RPM

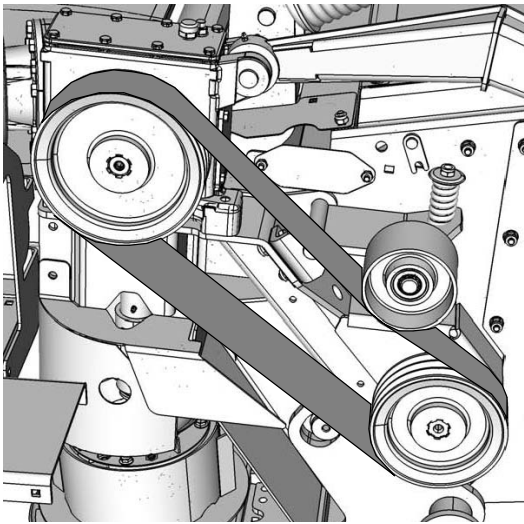

The machine may be equipped with a kit consisting of a V-belt pulley and three (3) V-belts which change the rotation of the machine rotors to 1200 RPM.

→ »Rollers« Page 77

Extra equipment

Chain

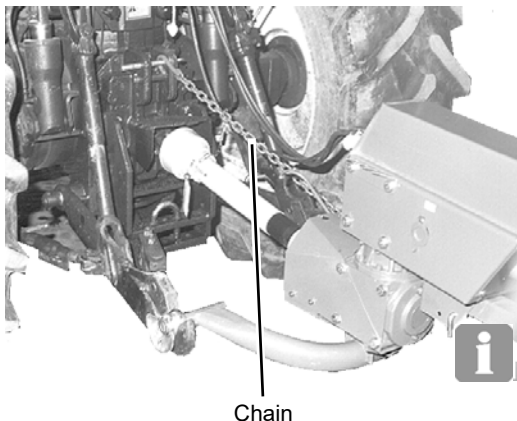

A chain is available as extra equipment to prevent the tractor's lift arms from lowering. The chain is fitted between the highest point on the tractor and one of the lift arms.

→ »Attachment of the tractor« Page 51

→ »Weight« Page 36



This equipment is not a safety chain that secures the connection between the tractor and the machine.

→ »Safety chain« Page 102

P.T.O. shaft

8 or 21 splines

The machine can be fitted with P.T.O. shafts with either 8 or 21 splines.



Hour counter

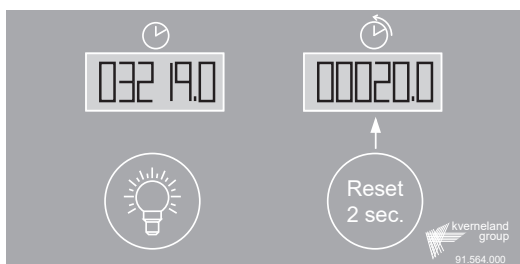

The machine can be fitted with an hour counter which has the following functions:

- Total time, which records the total number of hours the machine has run throughout its service life.
- Trip function, which can be reset to record the individual hours the machine has been running for a particular period.

The hour counter only records time when the P.T.O. shaft is coupled to the machine.

The hour counter also has the following features:

- A light function on both displays so the hour counter can be read in the dark.
- There is need for an external power source as its own power requirements are generated when the P.T.O. shaft is coupled.

Hydraulic system

Fault	Possible cause	Solution	Page
Hydraulic system	The machine's hydraulic functions do not work	Check that the hydraulic hoses are correctly connected to the tractor's hydraulic outlet	60
	The machine's hydraulic functions seem sluggish	Insufficient amount of oil and / or oil pressure from the tractor	
		Check all hydraulic hoses for leaks	

Cutterbar

Fault	Possible cause	Solution	Page
Heavy skid marks on the ground behind the machine	There is too much downward pressure on the cutterbar	Adjust the springs	93
Uneven stubble	Too slow / forward speed	Increase speed / forward speed	37
	The tractor RPM on the P.T.O. is too low	Check RPM	37
	The blades are blunt or individual blades are missing	Turn or replace the blades	148
	The machine is not correctly balanced	Adjust the springs	93
Stripes in the stubble ¹	The cutterbar is not correctly angled for the crop in question	Adjust the angle of the cutterbar	88
	The cutterbar is fitted with high skids ³	Install the skids lower ³	165
		Note! The field must be free of stones	
	Build up of crop on the cutting discs	Increase speed / forward speed	166
		Affix throwing wings ³ on the cutting discs	
		Set the rotor to 900 RPM	74, 167
		Rotation of the rotor adjusted to 500 min ³	
		Rotation of the rotor adjusted to 1015 RPM ³	
Rotation of the rollers adjusted to 750 min ³	77, 169		
Rotation of the rollers adjusted to 1200 RPM ³			

Troubleshooting

Fault	Possible cause	Solution	Page
Uneven swathes	The rotor's RPM is too low	Set the rotor to 900 RPM	74
		Rotation of the rollers adjusted to 1200 RPM ³	77,169
	Adjust the conditioner plate	69, 73	
The cutting unit receives violent shocks during road transport	Incorrect setting of the deflector plate	Adjust the deflector plates	87
	The machine's accumulator has too little pressure or is defective	Check or replace the accumulator ²	163
Conditioning too weak	The safety valve is closed	The safety valve must be open	63
	Too much distance between the conditioner plate and the rotor	Adjust the conditioner plate	69, 73
	The rotor's RPM is too low	Set the rotor to 900 RPM	74
	The rotor V-belts are not tightened sufficiently	Check the V-belts	126
	The rotor V-belts are worn	Replace the V-belts	157
	Too little roller pressure	Adjust the roller pressure	81
	Driving speed is too high	Reduce driving speed	
	The V-belts at the roller are not tightened sufficiently	Check the V-belts	126
Blocking of crops	The roller V-belts are worn	Replace the V-belts	157
	The V-belts at the rotor/roller are not tightened sufficiently	Check the V-belts	126
	V-belts at the rotor/roller are worn	Replace the V-belts	157
Crop spills between the machine and the Bx-equipment ³	The conditioner plate is too close to the rotor	Change the setting of the conditioner plate	69
	The rotor's RPM is too low	Set the rotor to 900 RPM	74
		Rotation of the rotor adjusted to 1015 RPM ³	74,167
The rollers' RPM is too low	Rotation of the rollers adjusted to 1200 RPM ³	77,169	
	Very hot cutterbar	Too much oil in the cutterbar	fill the correct amount of oil at the cutterbar
Wrong oil type		Change to the correct oil type	177
The crop glides underneath the rotor	The throwing wings ³ are not mounted on the cutting discs	Affix throwing wings ³	166
	The throwing wings ³ are worn	Replace the throwing wings ³	166

P.T.O. shaft

Fault	Possible cause	Solution	Page
Very hot friction clutch	The RPM on the P.T.O. shaft is too low	Check RPM	37
	The friction discs in the coupling are worn	Replace the friction discs in the clutch	163
Poor transfer of power/torque to the machine	The friction discs in the coupling are worn	Replace the friction discs in the clutch	163

- ¹ Problems with stripes are more likely to occur when mowing short, strong, spring crops in less than ideal weather conditions. Always begin by checking that the blades on the cutting discs are sharp.
- ² May only be carried out by authorized service personnel.
- ³ Extra equipment - Page 164.

Warranty

Guidelines for warranty

The warranty period for our product is 12 months from the date of purchase. The warranty does not include the parts subject to wear.

Warranty claims can be made with Kverneland warranty application which must be filled out by your local Kverneland dealer where your machine/equipment was purchased.

No liability is accepted for any damage that may arise

We are not liable for compensation for any damage not arising from the machine/equipment itself. This also includes damage arising from incorrect usage of the machine/equipment.

Therefore, read this instruction manual before putting the machine/equipment to use. Furthermore, always check that the machine/equipment works correctly before and during use.

When the machine reaches the end of its service life, it must be disposed of in the correct way. Observe the following:

Metal parts

Take usable parts to an authorized recycling plant. Larger scrap parts must be taken to an authorized wrecker where they can be processed in accordance with applicable regulations.

Rubber parts

Take usable parts to an authorized recycling plant where they can be processed in accordance with applicable regulations.

Plastic

Take usable parts to an authorized recycling plant where they can be processed in accordance with applicable regulations.

Hydraulic Oil

The oil must be emptied from the machine.
Used oil must be taken to a wrecker where it can be processed in accordance with applicable regulations.

Electronic parts

Take usable parts to an authorized recycling plant where they can be processed in accordance with applicable regulations.

Conversion table

Basic unit:	SI - unit	Conversion figures:
Length	1 m	39.4 in = 3.3 ft = 1.1 yd = 0.00062 miles (US)
Area	1 m ²	1.2 yd ² = 10.8 ft ² = 0.00025 acre = 0.0001 ha
Volume	1 dm ³ (1 l)	61 in ³ = 0.035 ft ³ = 0.22 gallon (Imp) = 0.26 gallon (US)
Speed	1 m/sec	3.6 km/h = 2.24 mph = 3.28 ft/sec
Power	1 N	0.10 kp = 0.22 lbf
Effect	1 kW	1.36 hp = 102 kpm/sec
Mass	1 kg	2.2 lbs = 0.0197 cwt = 35 oz
Torque moment	1 Nm	0.102 kpm = 8.8 lb-in = 0.74 ft. lbs.
Pressure	1 bar	0.01 atm. (kp/cm ²) = 0.14 psi
RPM	min ⁻¹ = revolutions / min = RPM	

Lubricants

Only check the oil level when there is a visible loss of oil while the machine is level.

Transmission oil and lubricant must meet the following requirements

Specifications			
Transmission oil		Lubricant	
SAE J-2360	80W-90	NLGI GC/LB	2
API	GL-4		

Technical information

Torque moment

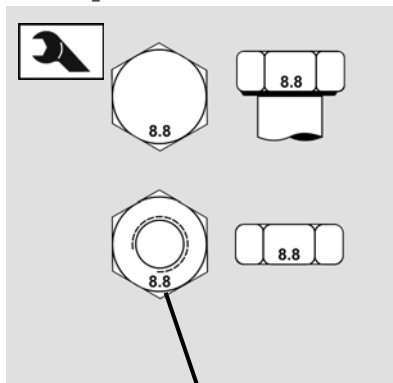

Specification of quality class

WARNING

Use the correct torque

Fasten the screws, nuts and bolts using the indicated torque. Otherwise, this may result in damaging the machine and cause serious injury or death.

Note the quality class for screws, nuts and bolts.

Note the size of screw, nut and bolt and find the corresponding torque in the table.

Tighten screws, nuts and bolts to the indicated values, provided that no other value is indicated.

Tightening torque for grade 8.8 black and/or galvanized and ungreased bolts when tightened on a smooth surface or a plain washer									
Thread dia. mm	5	6	8	10	12	14	16	20	22
Nm	5.5	10	24	47	81	128	197	385	518
ft/lbs	4	7.5	18	35	60	94.5	145.5	284	382.5

The tables above apply unless otherwise indicated in the instruction manual for this machine.

A			
As required			
Blades	148	Spreading device	164
Cutting disc	151	Stubble height	165
Drive shaft	159	Throwing wings	166
Stone guard and counter blade	154		
Tarpaulin	162	F	
V-belt	157	Friction clutch	163
Wheel	162		
Y-fingers	156	H	
		Hydraulic connection	60
		Hydraulics	20
C			
Checking the cutting unit	62	I	
Cleaning	104	Initial start	61
Conversion table	177		
		L	
D		Lubricants	177
Daily inspection			
Blades	117	M	
Cone	121	Maintenance	
Cutting disc	120	Maintenance intervals	112
Rollers	123		
Stone guard and counter blade	124	N	
Tarpaulin	127	Notes	176
V-belt	126		
Wheel	128	P	
Y-fingers	122	P.T.O.	21
Disposal		P.T.O. shaft	163
Electronic parts	175	Parking	
Hydraulic oil	175	Disconnection	106
Metal parts	175	Storage	108
Plastic	175	Preparation	
Rubber parts	175	Attachment of the tractor	51
E		R	
Every 200 hours of use		Rollers	
Center gear	135, 143	Changing the roller pressure	81
Cone	139	Distance between rollers	83
Drive shaft	140	Roller pressure	80
Main gear	133		
Rollers	137	S	
Swivel gear	136	Safety	
Extra equipment		Safety symbols	10
Bx-equipment	164	Spare parts	28
Chain	170	Stubble height	
EXPRESS	166	Long stubble height	90
Hour counter	170	Short stubble height	88
P.T.O shaft	170		
RPM of rollers	169		
RPM of rotor	167		
Skids	165		

Index

Swivel gear	
Checking the RPM	45
Number of revolutions on the P.T.O. outlet	46
Synopsis	33

T

Target group for the Instruction Manual	5
Technical data	
Dimensions	34
Specifications	37
Technical information	177
Torque moment	178
Tractor requirements	41
Transport on public roads	
Check	103
Safety chain	102
Traveling on public roads	103
Troubleshooting	171

W

Warranty	174
----------	-----