

RA1047T

Operator's manual Original operator's manual

Edition	04.2013
Date of print	07.2014
Language	EN-US
Machine number	VF69680101
Model	VF6968
Document number	VF16660621.EN

Machine identification

In order for your dealer to assist you as efficiently as possible, you will need to provide some information about your machine. Please enter the details here.

Designation	RA1047T
Working width	4,70 m (15.4 ft)
Weight	665 kg (1466 lbs)
Machine number	VF6968_ _ _ _
Accessories	
Address of supplier	
Address of manufacturer	Kverneland Group Kerteminde AS Taarpstrandvej 25 DK-5300 Kerteminde Denmark Tel: +45 65 19 19 00

Table of contents

Preface	4	General	59
Target group for this operator's manual	4	Lowering the machine	60
Symbols used	5	Operation	63
Safety	7	Safety	63
For your safety	8	General	64
DANGER, WARNING and CAUTION labels	9	Crop processing	64
Who is allowed to operate the machine?	15	Using the machine	65
General		Working speed	66
safety information	15	Driving on headlands	67
Coupling	18	Cleaning and care	68
Hydraulics	18	Safety	68
Road transport	19	General	69
Operation	20	Cleaning	69
Uncoupling	21	Care	69
Care and maintenance	22	Parking and storage	70
Further regulations	23	Safety	70
Getting to know the machine	25	General	71
Range of application	25	Uncoupling the machine	72
Features	25	After the end of the season	72
Designation of components	26	Maintenance	73
Technical specifications	27	Safety	73
Delivery and assembly	31	General	74
Checking the scope of delivery	31	Screwed connections	77
Check tandem axle	32	Special tightening torques	78
Length of PTO shaft	33	Lubrication points for grease	78
Coupling the machine	35	Lubricating the PTO shafts	80
Safety	35	Filling quantities	81
General	35	Tires	81
Coupling the machine	36	Hydraulics	82
Safety chain	39	Accessories	83
Coupling the PTO shaft	40	Tine saver	83
Connections	41	Contact roller	83
Preparing for use	45	Lift link drawbar	83
Safety	45	Lighting unit USA	84
General	46	Spare wheel	84
Adjusting the machine	46	Fault elimination	85
Rotor pitch	47	Troubleshooting	85
Working depth	49	Circuit diagrams	87
Adjusting the drawbar height	51	Hydraulic circuit diagram	87
Adjusting the support wheel [+]	52	Lighting equipment circuit diagram - USA	88
Road transport	53	Decommissioning	89
Safety	53	Disposal	89
General	53	EC Declaration of Conformity	90
Prior to road transport	54	Conforms to	
Road transport	58	EC Directive	
Preparations on the field	59	2006/42/EC	90
Safety	59	Index	91

Preface

Target group for this operator's manual



WARNING

Simplified illustrations for better understanding

Illustrations of the machine in the operator's manual are shown without protective equipment – or with the protective equipment open – for better understanding. Be sure to observe the safety information and follow the handling instructions in the operator's manual. Otherwise, serious or fatal injury may be caused as a result.

This operator's manual is intended for trained agriculturists and persons who are otherwise qualified for agricultural activities and have received instruction in working with this machine.

Minimum age

Children under the age of 16 are not permitted to operate the machine.

For your safety

You must familiarise yourself with the contents of this operator's manual before assembly or initial operation of the machine. In this way, you will achieve optimum work results and operational safety. The operator's manual forms an integral part of the machine and must always be kept at hand. This will ensure that you:

- avoid accidents.
- comply with warranty conditions.
- have a fully functional machine in good working order at all times.

Demonstration and training

Your dealer will provide instruction on operation and care of the machine.

Information for the employer

All personnel are to be regularly, but at least once a year, instructed on the use of the machine, in accordance with the regulations of the national organisation for Health and Safety at Work. Untrained or unauthorised persons are not permitted to use the machine.

You are responsible for ensuring that the machine is operated and maintained safely. Make sure that you and all other persons that operate, maintain or work in close proximity with the machine are familiar with the operating and maintenance regulations, as well as the corresponding safety instructions in this operator's manual.

Symbols used

In this operator's manual, the following symbols and terms have been used:

- A bullet point accompanies each item in a list.
- ▶ A triangle indicates operating functions which must be performed.

→ An arrow indicates a cross-reference to other sections of this manual.

[+] A plus sign indicates additional equipment which is not included in the standard version.

We have also used pictograms to help you find instructions more quickly:



The "Information" pictogram indicates tips and additional information.



The "Examples" pictogram indicates examples that assist understanding of the instructions.



The spanner indicates tips for assembly or adjustment work.



The brush indicates the points that must be lubricated using the brush.



The grease gun indicates the points that must be lubricated using the grease gun.



▶ Switch on the tractor.



▶ Shut off the engine, set the parking brake, remove the ignition key and secure the tractor against rolling away.

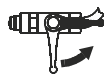

Open the ball valve.



Close the ball valve.



This arrow in the diagram shows the direction of travel.

Preface



California Proposition 65

WARNING

Engine exhaust, some of its constituents, certain machine components and fluids, contain or emit chemicals known to the State of California to cause cancer and birth defects or other reproductive harm.

SAFETY FIRST

This symbol, the industry's "Safety Alert Symbol", is used throughout this manual and on labels on the machine itself to warn of the possibility of personal injury. Read these instructions carefully. It is essential that you read the instructions and safety regulations before you attempt to assemble or use this unit.

DANGER

Indicates an imminently hazardous situation which, if not avoided, will result in death or serious injury.

WARNING

Indicates a potentially hazardous situation which, if not avoided, could result in death or serious injury.

CAUTION

Indicates a potentially hazardous situation which, if not avoided, could result in minor or moderate injury.



For your safety

Know your equipment and its limitations. Read this entire manual before attempting start and operate the units.

This chapter contains general safety instructions. Each chapter of the operator's manual contains additional specific safety information which is not described here. Observe the safety information:

- in the interest of your own safety.
- in the interest of the safety of others.
- to ensure the safety of the machine.

Numerous risks can result from handling agricultural machinery in the wrong way. Therefore, always work with particular care and never under time pressure.

Information for the employer

Inform all persons who work with the machine about this safety information at regular intervals and in accordance with statutory regulations.



DANGER, WARNING and CAUTION labels

Safety-related stickers attached to the machine indicate potential hazards. The stickers must not be removed. Illegible or missing stickers should be replaced. You can obtain new stickers as replacement parts from your dealer.

DANGER, WARNING and CAUTION labels on the machine

WARNING
UNEXPECTED MOVEMENT
• THE ROTOR MAY TURN UNEXPECTEDLY DUE TO CENTRIFUGAL FORCES.
TO AVOID DEATH OR SERIOUS INJURY: SECURE THE ROTOR FOR TRANSPORT.

DANGER
PARTS EJECTED AT SPEED
• PARTS MAY BECOME DETACHED AND EJECTED AT SPEED.
TO AVOID DEATH OR SERIOUS INJURY: KEEP IN A SAFE DISTANCE.

DANGER
ROTATING PARTS
• ACUTE RISK OF INJURY BY ROTATING PARTS.
TO AVOID DEATH OR SERIOUS INJURY: KEEP AWAY FROM RUNNING ROTORS.

DANGER
PARTS EJECTED AT SPEED
• PARTS MAY BECOME DETACHED AND EJECTED AT SPEED.
TO AVOID DEATH OR SERIOUS INJURY: KEEP IN A SAFE DISTANCE.

WARNING
INADVERTENT OPERATION
• RISK OF DEATH OR INJURY BY INADVERTENT OPERATION.
TO AVOID DEATH OR SERIOUS INJURY: SWITCH OFF THE ENGINE.

WARNING
UNEXPECTED MOVEMENT
• THE SNATCH FORMER MAY FOLD DOWN UNEXPECTEDLY IF IT IS NOT SECURED.
TO AVOID FATAL OR SERIOUS INJURY: SECURE THE SNATCH FORMER.

CAUTION
READ THE MANUAL
• THE MACHINE MUST NOT BE USED BEFORE READING THE OPERATING MANUAL.
TO AVOID FATAL OR SERIOUS INJURY: READ THE MANUAL FIRST.

CAUTION
PTO SHAFT SPEED 540 RPM
• THE SPECIFIED MAXIMUM SHAFT SPEED OF 540 RPM MUST NOT BE EXCEEDED.
TO AVOID MACHINE DAMAGE AND INJURY: MAINTAIN THE PERMITTED SHAFT SPEED.

WARNING
AREA OF RISK
• RISK OF DEATH OR INJURY ON COUPLING, UNCOUPLING OR OPERATING.
TO AVOID DEATH OR SERIOUS INJURY: KEEP OUT OF THIS AREA.

CAUTION
MAXIMUM HYDRAULIC PRESSURE
• THE TRACTOR'S HYDRAULIC PRESSURE MUST NOT EXCEED 210 BAR (USE PSI).
TO AVOID MACHINE DAMAGE AND INJURY: CHECK THE HYDRAULIC PRESSURE.

WARNING
RISK OF CRUSHING
• NEVER REACH INTO AN AREA WHERE PARTS ARE STILL LIKELY TO MOVE.
TO AVOID FATAL OR SERIOUS INJURY: KEEP YOUR HANDS OUT.

DANGER
NO OTHER OPERATOR!
CONTACT CAN CAUSE DEATH.
KEEP AWAY!
DO NOT OPERATE WITHOUT THE OPERATOR'S SEAT BELT AND SAFETY SWITCHES.
DO NOT OPERATE WITHOUT THE OPERATOR'S SEAT BELT AND SAFETY SWITCHES.
DO NOT USE PTO ADAPTERS.

DANGER
GUARD MISSING
DO NOT OPERATE!



Meaning of DANGER, WARNING and CAUTION labels

! DANGER		
		<p>PARTS EJECTED AT SPEED</p> <ul style="list-style-type: none"> • PARTS MAY BECOME DETACHED AND EJECTED AT SPEED. <p>TO AVOID DEATH OR SERIOUS INJURY: KEEP IN A SAFE DISTANCE</p>
		VF16661493

! DANGER		
		<p>ROTATING PARTS</p> <ul style="list-style-type: none"> • ACUTE RISK OF INJURY BY ROTATING PARTS. <p>TO AVOID DEATH OR SERIOUS INJURY: KEEP AWAY FROM RUNNING ROTORS</p>
		VF16661491

! DANGER
<p style="text-align: center;">ROTATING DRIVELINE CONTACT CAN CAUSE DEATH KEEP AWAY!</p> <p>DO NOT OPERATE WITHOUT-</p> <ul style="list-style-type: none"> • ALL DRIVELINE, TRACTOR AND EQUIPMENT SHIELDS IN PLACE. • DRIVELINES SECURELY ATTACHED AT BOTH ENDS. • DRIVELINE SHIELDS THAT TURN FREELY ON DRIVELINE.
KT50908000

Outer tube.

! DANGER
<p style="text-align: center;">SHIELD MISSING DO NOT OPERATE</p>
KT50908000

Inner tube.



 WARNING		
		<p>RISK OF CRUSHING</p> <ul style="list-style-type: none">• NEVER REACH INTO AN AREA WHERE PARTS ARE STILL LIKELY TO MOVE. <p>TO AVOID FATAL OR SERIOUS INJURY: KEEP YOUR HANDS OUT</p>

VF16661497

 WARNING		
		<p>AREA OF RISK</p> <ul style="list-style-type: none">• RISK OF DEATH OR INJURY ON COUPLING, UNCOUPLING OR OPERATING. <p>TO AVOID DEATH OR SERIOUS INJURY: KEEP OUT OF THIS AREA</p>

VF16661499

 WARNING		
		<p>INADVERTENT OPERATION</p> <ul style="list-style-type: none">• RISK OF DEATH OR INJURY BY INADVERTENT OPERATION. <p>TO AVOID DEATH OR SERIOUS INJURY: SWITCH OFF THE ENGINE</p>

VF16661501

 WARNING		
		<p>UNEXPECTED MOVEMENT</p> <ul style="list-style-type: none">• THE SWATH FORMER MAY FOLD DOWN UNEXPECTEDLY IF IT IS NOT SECURED. <p>TO AVOID FATAL OR SERIOUS INJURY: SECURE THE SWATH FORMER</p>

VF16661503

 WARNING		
		<p>UNEXPECTED MOVEMENT</p> <ul style="list-style-type: none">• THE ROTOR MAY TURN UNEXPECTEDLY DUE TO CENTRIFUGAL FORCES. <p>TO AVOID DEATH OR SERIOUS INJURY: SECURE THE ROTOR FOR TRANSPORT</p>

VF16661505



CAUTION	
	<p>READ THE MANUAL</p> <ul style="list-style-type: none"> • THE MACHINE MUST NOT BE USED BEFORE READING THE OPERATING MANUAL. <p>TO AVOID FATAL OR SERIOUS INJURY: READ THE MANUAL FIRST</p>
<small>VF16661513</small>	

CAUTION	
<p>max</p>	<p>PTO SHAFT SPEED 540 RPM</p> <ul style="list-style-type: none"> • THE SPECIFIED MAXIMUM SHAFT SPEED OF 540 RPM MUST NOT BE EXCEEDED. <p>TO AVOID MACHINE DAMAGE AND INJURY: MAINTAIN THE PERMITTED SHAFT SPEED</p>
<small>VF16661515</small>	

CAUTION	
<p>max</p> <p>210 bar</p>	<p>MAXIMUM HYDRAULIC PRESSURE</p> <ul style="list-style-type: none"> • THE TRACTOR'S HYDRAULIC PRESSURE MUST NOT EXCEED 210 BAR (3045 PSI). <p>TO AVOID MACHINE DAMAGE AND INJURY: CHECK THE HYDRAULIC PRESSURE</p>
<small>VF16661517</small>	



Lubrication points

Lubrication points are marked with an information label. Lubricate the machine in accordance with the instructions in the "Maintenance" chapter.



Signalling equipment – USA

On the machine there are signalling equipment, signs and stickers that serve to ensure safety in road traffic. The signalling equipment must be in good working order at all times. The signs and stickers must not be removed. Illegible or missing labels should be replaced. You can obtain new labels as spare parts from your dealer.

If the implement, in the transport position, obscures the effective illumination of any flashing, extremity, tail or stop lamp on the tractor, the implement must be fitted with lighting appropriate to take the place of the lamp(s) obscured. See your authorized dealer for an appropriate lighting kit.

Signalling equipment

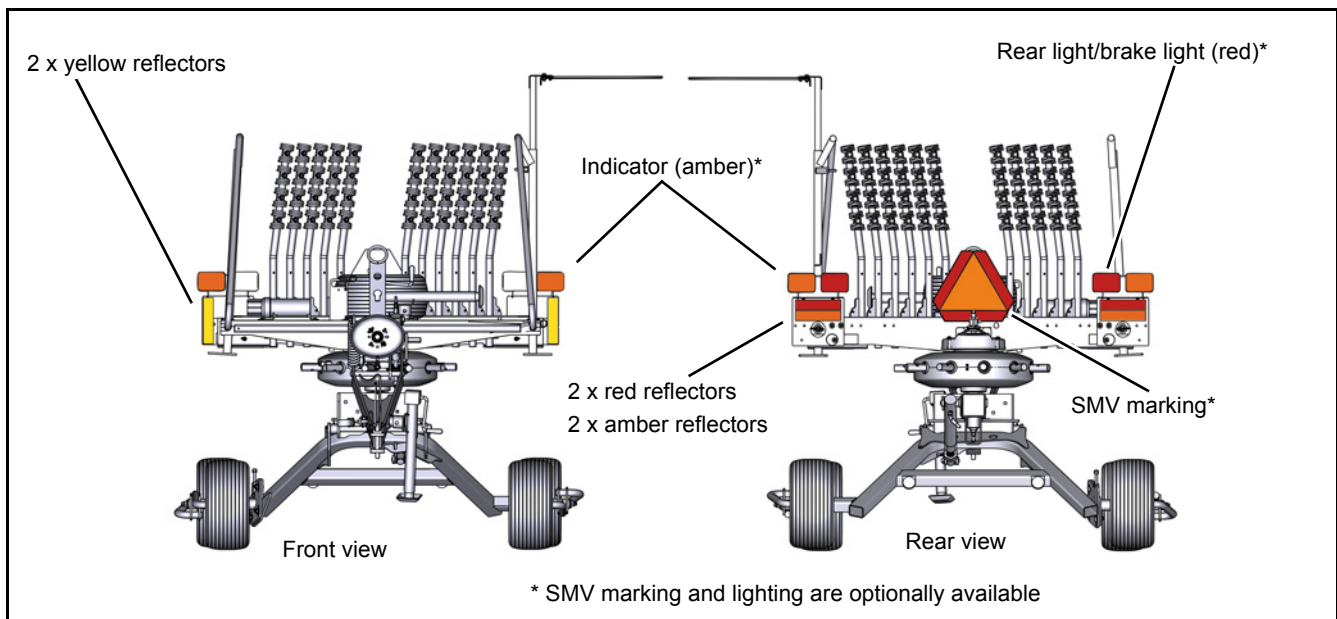



Signs

Additional markings are required for road transport in some U.S. states and some Canadian provinces:



Marking for slow-moving vehicle – SMV

This SMV emblem shall be used on all slow moving machines when operated or traveling on public roads.

- On slow moving machines with design specifications of a maximum speed of 40 km/h (25 mph) or less, the SMV emblem shall be used.
- On slow moving machines with design specifications of speed greater than 40 km/h (25 mph) but not exceeding 65 km/h (40 mph):
 - a SMV emblem shall be used and
 - a Speed Identification Symbol (SIS) shall be used.



Marking for maximum speed (Speed identification symbol – SIS)

The scope of this standard is primarily directed to identifying agricultural equipment that have been designed in their original equipment configuration for specified ground speeds greater than 40 km/h (25 mph) but under 65 km/h (40 mph).



Who is allowed to operate the machine?

General safety information

Only qualified persons may operate the machine

Only qualified persons who have been informed of the dangers associated with handling the machine are permitted to operate, service or repair the machine. The necessary knowledge can be gained in the course of agricultural vocational training, professional training or intensive instruction.

WARNING

The general safety information and warning signs apply to every phase of the life cycle of the machine and to every application.



Switch off the tractor and secure it

Before you dismount:

- ▶ Disengage the PTO
- ▶ Lower all implements to the ground
- ▶ Place all controls in their neutral or park position
- ▶ Set the parking brake
- ▶ Switch off the tractor.
- ▶ Remove the ignition key.
- ▶ Secure the tractor against rolling away.

An unsecured tractor can run you over or trap you. Otherwise, serious or fatal injury may be caused as a result.

Operate for the first time only after proper training

The machine may only be put into operation after proper training has been provided by an authorized dealer. Operation without proper training can lead to damage to the machine due to incorrect operation, or may cause accidents.

Safety is your responsibility

Follow the safety instructions. Ensure that all operators read and understand the manual and comply with the safety instructions. Prevent serious or fatal accidents by following the safety instructions.

Instructions in the event of malfunctions

In the event of a malfunction:

- ▶ shut down,
- ▶ stop and secure the machine immediately.
- ▶ Rectify the malfunction immediately yourself if qualified to do so,
- ▶ or seek the assistance of an authorized dealer.

Operating a faulty machine can cause accidents or damage.



No persons in the working area

Ensure that no persons are present in the slewing and working area of the machine. Persons could be caught by the machine within this area. This could result in fatal injury.

Proper working condition

Ensure that the tractor and the machine are always in proper working condition. Make sure that the tractor brakes work in synchronisation with the machine. Also follow the instructions in your tractor's operator's manual.



Switch off the tractor PTO shaft drive

Switch off the PTO shaft drive on the tractor when changing from work to transport position (and vice versa). Wait for moving parts to come to a stop. If this requirement is ignored, the consequence may be damage to the machine and even life-threatening injuries.



No reversing while the drive is running

Never drive in reverse with the PTO shaft drive switched on and in the work position if people could enter the working area of the machine. Switch off the PTO shaft drive. Rotating, unprotected parts can damage the machine and cause life-threatening injuries.

Specified workwear

Do not wear loose fitting or other inappropriate clothing. Loose fitting items of clothing may become caught in rotating parts. Wear workwear and protective clothing, request for the operating, environment and conditions. Serious or fatal injury may be caused if these guidelines are not followed.

No riding on the machine

Persons or objects must never be transported on the machine. Carrying passengers, especially children, on the machine is life threatening and prohibited. Serious or fatal injury may be caused as a result.

Safety for children

Never assume that children will remain where you last saw them. Be alert and shut your machine down if children into the work area. Never allow children to play on or operate the machine.

**Never work on the machine while it is running**

No operations may be performed on the machine while it is running. Objects or persons can be caught, drawn in or crushed. Serious or fatal injury may be caused as a result.

PTO shaft

Use only the PTO shafts specified by the manufacturer and read the attached operator's manual carefully. Adjust the length of the PTO shaft as required. Incorrect PTO shaft lengths can cause damage to the machine and personal injury.

Check and fasten the PTO shaft guard in position

The rotating PTO shaft is protected by the PTO shaft guard. Ensure that the guard is not damaged. Fasten the PTO shaft guard in position by connecting the chains on the machine and the tractor. Unguarded PTO shafts can cause life-threatening injuries.

Make sure the machine is standing level

Before changing from the transport to the work position (and vice versa), make sure the machine is standing level. Otherwise, damage to the machine and serious or fatal injury may be caused as a result.

Do not make any modifications to the machine

No modifications of any kind may be made to the machine. Unauthorised modifications can adversely affect the correct operation and safety of the machine and shorten its service life. Unauthorised modifications to the machine render the manufacturer's guarantee null and void and free the manufacturer from all liability.

PTO shaft speed 540 rpm

The specified maximum PTO shaft speed of 540 rpm must not be exceeded. A higher PTO shaft speed will damage the machine.

Unrestricted field of vision to the rear

After it has been coupled, ensure that you have an unrestricted view of the machine, in both its work and transport positions. Otherwise, dangerous situations may not be detected in time, resulting in accidents or damage.

Safety distance from raised and unsecured loads

Never work under suspended loads. Maintain a sufficient distance from raised and unsecured loads. Otherwise, serious or fatal injury may be caused as a result.



Coupling

Increased risk of injury

When the machine is being coupled to the tractor, there is an increased risk of injury. Therefore:



- Shut off the engine, set the parking brake, remove the ignition key and secure the tractor against rolling away.
- Never stand between the tractor and machine.
- Lock the PTO shaft securely on the PTO stub shafts of the tractor and the machine.

If this requirement is ignored, the consequence may be life-threatening injuries or damage to the machine.

Attaching electrical connections after assembly

The electrical supply to the tractor must not be connected when the lighting equipment is being fitted. Otherwise, short circuits will occur and the electronic system will be damaged.

Observe the operator's manual of the PTO shaft manufacturer

Observe the operator's manual of the PTO shaft manufacturer. It will provide you with instructions on how to handle the PTO shaft correctly. If these instructions are ignored, damage may be caused to the PTO shaft and machine.

Risk of tipping

When the machine is coupled to tractors with lower link quick-release couplings, the latter must be secured against unintentional opening. If the quick-release couplings open unintentionally, the tractor and machine may tip over. If this requirement is ignored, the consequence may be damage to the machine and even life-threatening injuries. Also follow the instructions in your tractor's operator's manual.

Hydraulics

Hydraulic connection at zero pressure only

Only connect hydraulic hoses to the tractor hydraulic system if the tractor and machine hydraulic system is at zero pressure. A pressurised hydraulic system can trigger unforeseen movements on the machine and can cause serious machine damage and personal injury. Serious or fatal injury may be caused as a result.

High pressures in the hydraulic system

The hydraulic system is under high pressure. Regularly check all lines, hoses, and screwed connections for leaks and externally visible damage. Do not use hands to search for suspected leaks. Only use suitable equipment when looking for leaks. Rectify any damage immediately. Fluid escaping under pressure can penetrate skin may result in injuries and fires. Seek medical attention immediately if injuries occur.

Replace hydraulic hoses every six years or earlier

Hydraulic hoses age without showing externally visible signs. Replace hydraulic hoses every six years, or earlier if aging or degradation is visible. Defective hydraulic lines can cause serious or fatal injuries.



Road transport

Ensuring road safety

The machine must conform to current national traffic regulations if you intend to drive it on public roads. Ensure the following:

- Lighting, warning and protective equipment must be fitted.
- The permissible transport widths and weights, axle loads, tire load-bearing capacities, laden weights and national speed restrictions must be observed.
- The maximum permissible road transport speed must be complied with, but not exceed 40 km/h (25 mph).
- Before driving on public roads, fully fold in all guard bars and secure the machine. All tine supports which have tips that point at right angles to the direction of travel must be removed.
- The machine should only be towed by agricultural or forestry tractors.

The empty weight of the tractor must be greater than the weight of the machine. The driver and keeper of the vehicle are liable should these conditions not be observed.



Close the ball valve

Close the ball valve before driving on the road. If the ball valve is open and there is an operating error, the machine may drop or swing out unexpectedly. This could cause traffic accidents and accidents with fatal consequences.

Check tire pressures

Check tire pressure on a regular basis. Incorrect tire pressures reduce the service life of a tire and cause unstable driving characteristics. Accidents with serious or fatal injuries may be caused as a result.

Altered driving and braking performance

Driving and braking performance are altered when the machine is coupled or hitched to the tractor. When cornering, take the overall width and balancing weight of the machine into consideration. Adjust your driving speed accordingly. A driving style which is not adapted to conditions can cause accidents. Accidents with serious or fatal injuries may be caused as a result.

Safety chain

When travelling on the road, always connect the machine and the tractor using a safety chain. Use a safety chain with a strength that corresponds to at least the total weight of the machine. Otherwise, serious or fatal injuries would be caused as a result.



Speed adjustment

In poor road conditions and at high speeds, significant forces can be generated which subject the tractor and machine material to high or excessive stresses. Adjust your driving speed to the road conditions. A driving style which is not adapted to conditions can cause accidents. Accidents with serious or fatal injuries may be caused as a result.

Check hitch pins

Hitch pins must be in perfect condition. Hitch pins must show no signs of wear and be properly secured. Otherwise, hitched machines may detach themselves of their own accord. Accidents with serious or fatal injuries may be caused as a result.

Operation

Ensure that the machine is in proper working condition

Do not operate the machine unless it is in proper working condition. Check all key components and their correct operation before use. Replace defective components. Defective components can cause material damage and personal injury.

Check the protective equipment

The protective equipment must not be removed or by-passed. Check all protective equipment before using the machine. Unprotected machine parts can cause serious or fatal injury.

Check the immediate vicinity

Check the area immediately surrounding the machine before driving off, and continually during operation. Make sure that you have an adequate view. Only begin work when the immediate vicinity is cleared of any persons or objects. Serious or fatal injury may be caused as a result.

Retighten all nuts, bolts and screws

Regularly check that nuts and bolts are correctly tightened. Retighten bolts if necessary. Nuts and bolts can work loose through machine use. The machine may be damaged or accidents caused as a result.

→ See »Tightening bolts«, page 77 for proper torque values.

The PTO shaft continues turning after it has been switched off

After the PTO shaft drive on the tractor has been switched off, the machine continues to run due to the moment of inertia. Maintain a sufficient safety distance until all moving parts have come to a complete standstill. Otherwise, damage to the machine and serious or fatal injury may be caused as a result.

Cornering and turning manoeuvres

Centrifugal forces are in operation during cornering. The machine's centre of gravity at the rear of the tractor is displaced. Be aware of the turning radius and the moment of inertia. A driving style which is not adapted to conditions can cause accidents. Accidents with serious or fatal injuries may be caused as a result.



Uncoupling

Increased risk of injury

There is an increased risk of injury when uncoupling the machine from the tractor. Therefore:



- Shut off the engine, set the parking brake, remove the ignition key and secure the tractor against rolling away.
- Never stand between the tractor and machine.
- Set the machine down on firm, secure and level ground.
- Ensure that the parking stand is securely locked.
- Place the PTO shaft in the holder provided.
- Secure the machine against rolling away (use wheel chocks).
- Do not disconnect hydraulic hoses until there is no pressure in the tractor and machine hydraulic system.
- Disconnect all electrical connections.

Failure to observe these instructions can result in serious or fatal injury.



Care and maintenance

Observe the care and maintenance intervals

Observe the periods specified in the operator's manual for recurrent checks and inspections. If these periods are not observed, damage to the machine and accidents may be caused as a result.

Use original parts

Many components have special properties that are essential for the stability and correct operation of the machine. Only spare parts and accessories supplied by the manufacturer have been tested and approved. Other products may adversely affect the correct operation of the machine and safety. Using non-OEM replacement parts renders the manufacturer's guarantee null and void and frees the manufacturer from all liability.



When performing care and maintenance work:



- Switch off the PTO shaft drive.
- Depressurise the hydraulic system.
- Whenever possible, uncouple the tractor.
- Place all controls in neutral or park.
- Set tractor parking brake.
- Shut off the engine, set the parking brake, remove the ignition key and secure the tractor against rolling away.
- Ensure the machine is standing on firm, secure and level ground, and provide additional support, if necessary.
- Secure the machine against rolling away (use wheel chocks).

Only if these regulations are observed can safe working be ensured during care and maintenance work.

Turn off the electrical supply

Prior to carrying out work on the electrical system, disconnect the system from the power supply. Systems being supplied with electrical power can cause damage to equipment and injury to persons.

Caution when cleaning with a high-pressure cleaner

Exercise caution when cleaning with a high-pressure cleaner. Bearings, seals and pipe unions are not waterproof. In order to prevent damage to the machine, the bearings, seals and pipe unions must not be exposed to direct contact with the high pressure water jet.

No aggressive washing additives

Do not use any aggressive washing additives for cleaning. Uncoated metal surfaces can be damaged.

Before carrying out welding work

Disconnect all electrical connections from the tractor when carrying out welding on the hitched machine. Damage may otherwise be caused to the electrical system.

Retighten all nuts, bolts and screws

All screwed/bolted connections that are loosened during maintenance and repair operations must be retightened. Serious injury and damage to property can be caused by loose pin and screw connections.

→ See »Tightening bolts«, page 77 for proper torque values.



Further regulations

Observe the regulations

In addition to the safety information listed above, please observe the following:

- Accident prevention regulations in your local area.
- Generally recognised safety regulations, occupational health requirements and road traffic regulations.
- The instructions provided in this operator's manual.
- Standards relating to operation, maintenance and repair.

Warranty

The warranty and manufacturer's liability will no longer be valid if the instructions provided in the chapter on Safety are not observed, if maintenance is inadequate or faulty, if the machine is used for purposes other than those for which it was intended and if it is overstressed, or if impermissible modifications are made to the machine.



Getting to know the machine

Range of application

This product is classified as replaceable equipment in accordance with EC directive 2006/42/EC and agricultural implement in accordance with ASABE S390.

The machine is a single-rotor rake, which is suitable only for the raking together of mown, stalked material (for example, hay or straw).

Proper use

Any use other than the use described above - such as silo spreading, any type of soil preparation, sweeping, or transmitting power to other machines - is not permitted. The manufacturer and dealers are not liable for damage caused by improper use. The risk is borne solely by the user.

Features

Flexible in operation

This single-wheel rake meets all the requirements of modern crop harvesting engineering. Important functions for field use are controlled during active operation.

The rake can be pulled by tractors of 15 kW (20 hp) or more.

Extensive equipment

The machine is equipped with a low-maintenance gear box and 12 tine supports on each rotor. The cranked tines achieve an excellent raking quality.

Easy changeover from work to transport position

The rake is easily changed over from the work to the transport position.

Raise height of 50 centimetres (20 in)

For road transport and on headlands, the machine can be quickly raised by roughly 50 centimetres (20 in). For working, lower the rotary rakes hydraulically from transport position back to work position.

Getting to know the machine

Designation of components

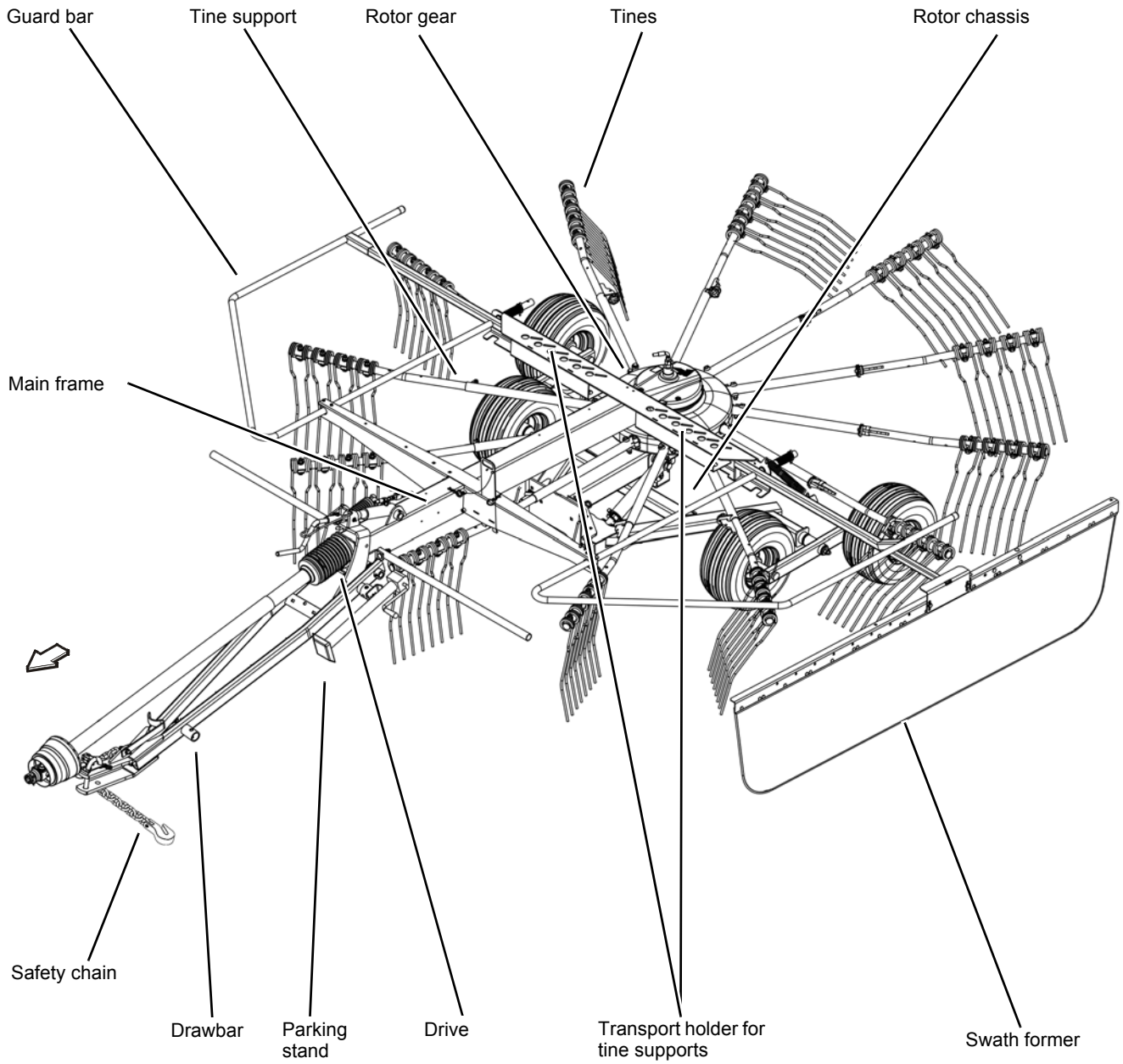

Getting to know the machine

Technical specifications

Dimensions in transport position

Model		VF6968
L _R	Length in transport position for road transport	4.73 m (15.52 ft)
H _R	Height in transport position for road transport	2.64 m (8.66 ft)
W _R	Width in transport position for road transport	2.39 m* / 2.73 m (7.84 ft* / 8.96 ft)
W _T	Width in transport position from tire to tire	2.39 m (7.84 ft)
T	Track width	1.31 m (4.30 ft)
	Height of top reflectors	1.26 m (4.13 ft)
	Distance between top reflectors	1.58 m (5.18 ft)
R	Height of bottom reflectors	0.40 m (1.31 ft)
S	Distance between bottom reflectors	0.65 m (2.13 ft)

* Swath former in transport position

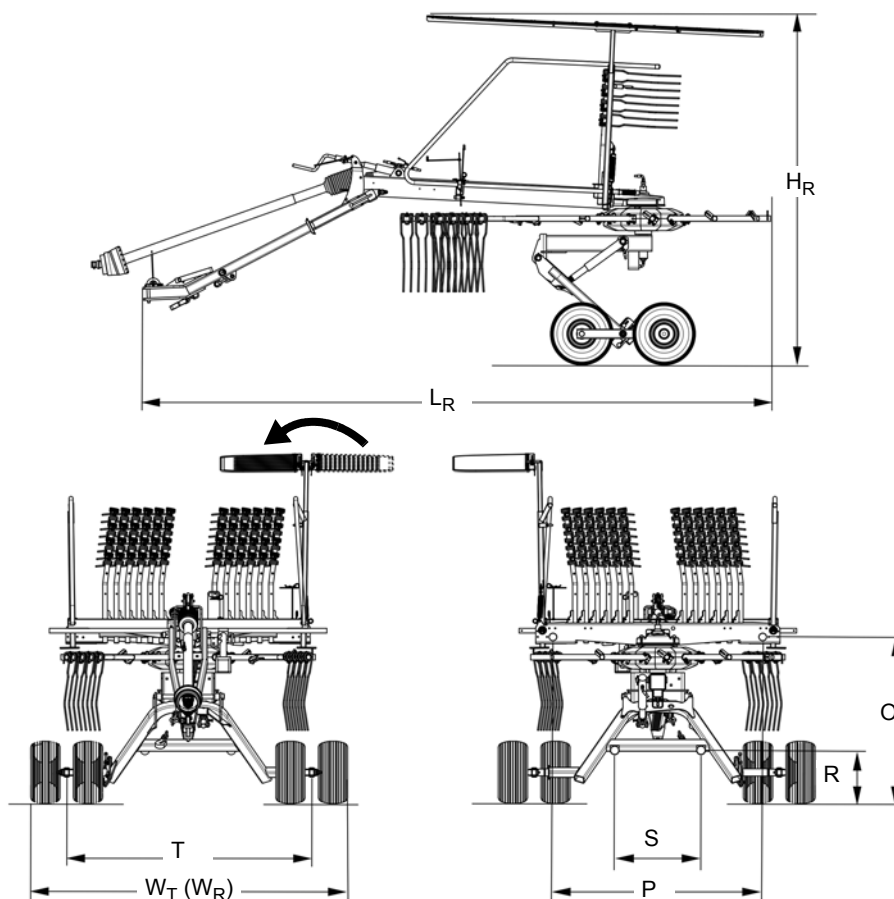

Getting to know the machine

Dimensions in work position

Model		VF6968
L _W	Length in work position	5.72 m (18.77 ft)
H _W	Height in work position	1.15 m (3.77 ft)
RD	Rotor diameter	3.65 m (11.98 ft)
SE	Width with swath former fully extended	4.70 m (15.42 ft)

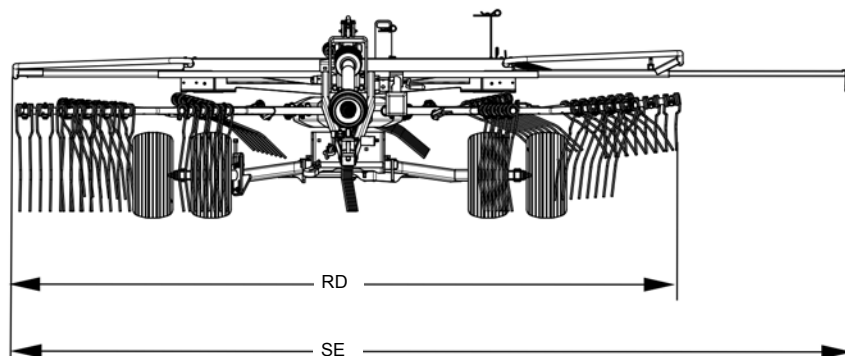
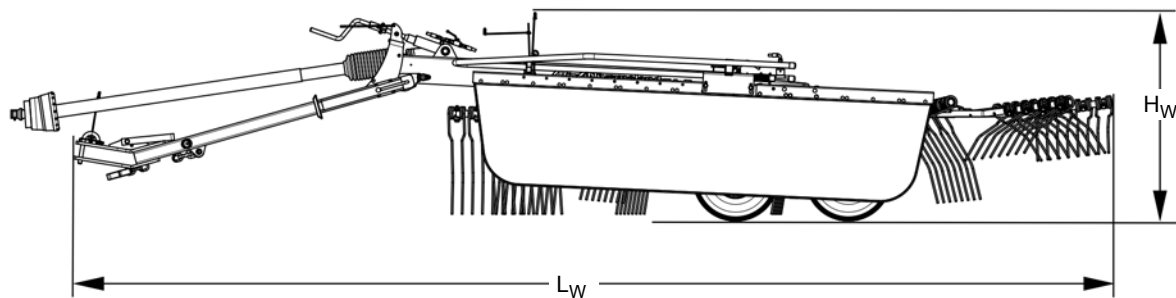

Getting to know the machine

Weights

Total weight	665 kg (1466 lbs)
Load supported on parking stand	120 kg (264.5 lbs)

Tractor equipment required

Output / connections		
	Minimum output of the tractor	15 kW (20 hp)
	Lighting equipment power supply	12 V, 7-pin plug socket SAE J560
	Hydraulic connections	1 x single-acting hydraulic control device
	Hydraulic pressure	150 - 210 bar (2175 - 3046 psi)
	Maximum PTO shaft speed	540 rpm
	Pending attachment	In accordance with ISO 6489-3
	Alternatively: lower link and lift link drawbar	Fixable in height and laterally

Getting to know the machine

Machine equipment

Swath deposit		
	Swath former	Standard
Rotors / tine supports / tines		
	Number of rotors	1
	Number of tine supports per rotor	12
	Number of tines per tine support	4
	Removable tine arms	Standard
	Rotor height adjustment	Hydraulic/mechanical
	Tine saver	[+]
Wheels		
	Rotor chassis	18 x 8.50-8 PR 6
Safety accessories		
	Safety chain	Standard
	Lighting equipment	[+]
	Warning signs	[+]
PTO shaft		
	PTO shaft	Standard

Measurement of airborne sound emissions

The airborne sound emissions from the machine are below the levels stipulated by machinery directive 2006/42/EC.

- A-weighted sound level in the workplace:
< 70 dB(A)
- Currently C-weighted sound level:
< 63 Pa (130 dB based on 20 µPa)
- A-weighted sound level on the machine:
< 80 dB(A)

Checking the scope of delivery

Delivery is in the fully assembled state

The machine is delivered fully assembled. Using the check list, check the loose parts on delivery. If any parts of the machine have not been fitted or are missing, please contact your dealer.

WARNING

Do not assemble the machine yourself

Trained personnel are required to assemble the machine. Do not perform assembly work yourself. The following points are required to be met for the machine to be in proper condition:

- Observance of the sequence of work steps.
- Compliance with tolerances and torques.
- Knowledge of work safety during assembly.

Incorrect assembly can result in damage to the machine or accidents.



If parts are missing or have been damaged during transportation, please inform the dealer, importer or manufacturer immediately.

Check list for parts which were supplied loose	Quantity
PTO shaft for drive	1
Tine support placing swaths on the left	12
Swath former	1
Operator's manual	1
Spare part manual	1
Additional equipment	See delivery note

Operator's manual

The operator's manual and spare part manual can be found in the document box on the machine.

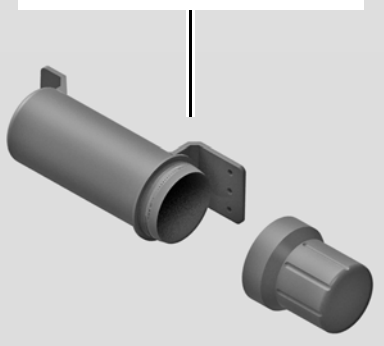

The operator's manual belongs with the machine and must always be kept on board. A document box for the operator's manual and spare part manual is mounted on the main frame.

Delivery and assembly

Check tandem axle



WARNING

Ensure that the tandem axle is positioned correctly

Ensure that the tandem axles are positioned correctly. If they are positioned incorrectly, this will cause damage to the machine.

- ▶ Check that the tandem axles are aligned correctly.
- The narrow track is at the front in relation to the direction of travel.
- The wide track is at the back in relation to the direction of travel.

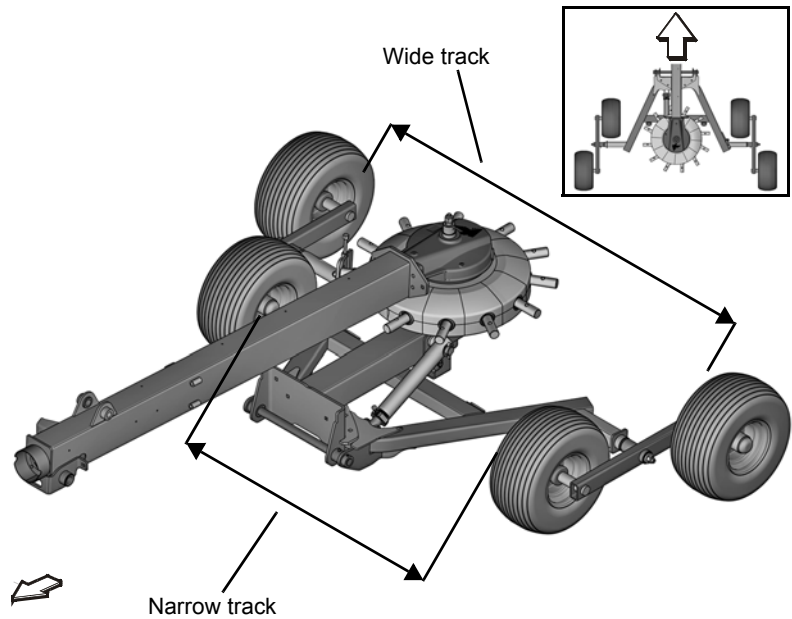

Length of PTO shaft

The length of the PTO shaft was selected at the factory to suit almost all types of tractors. Only in exceptional cases is a correction of the PTO shaft length required on individual tractors. Check the length of the PTO shaft on each tractor prior to first use.

A manufacturer's operator's manual for the PTO shaft is enclosed. This includes detailed information on the relevant version of the PTO shaft and must be observed.

Safety

WARNING

Switch off the tractor and secure it

Before you dismount:

- ▶ Disengage the PTO
- ▶ Lower all implements to the ground
- ▶ Place all controls in their neutral or park position
- ▶ Set the parking brake
- ▶ Switch off the tractor.
- ▶ Remove the ignition key.
- ▶ Secure the tractor against rolling away.

An unsecured tractor can run you over or trap you.

Otherwise, serious or fatal injury may be caused as a result.

Checking the angle of lock

The PTO shaft has a wide hinge joint giving the tractor a steering angle of up to 80°. Make sure that the PTO shaft is not damaged during sharp cornering. This would result in damage to the machine.

Correct length

A PTO shaft that is too long must not be used. This would result in damage to the drive bearings of the tractor and the machine.



Checking the length of the PTO shaft

- ▶ Couple the machine to the tractor without the PTO shaft.
- ▶ Lower the lower link of the tractor.
- ▶ Set the combination (tractor and machine) to the smallest steering angle.
- ▶ Shut off the engine, set the parking brake, remove the ignition key and secure the tractor against rolling away.



Delivery and assembly

Shortening the PTO shaft

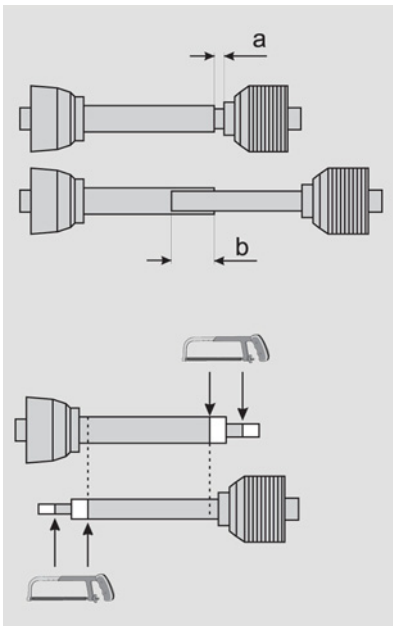

- ▶ Pull the PTO shaft apart and connect one half to the tractor PTO shaft drive and one to the machine and secure them.
- ▶ Place the two shaft halves next to each other and:
 - Check for a minimum of 250 mm (10 in) overlap (b).
 - Check that the PTO shaft is not blocked at each end. Minimum distance (a) = 20 mm (1 in).
- ▶ Shorten both the sliding tube and guard tube to the same size.
- ▶ Deburr the ends of the tubes.
- ▶ Remove the shavings.
- ▶ Grease the sliding surfaces well.

Fitting the PTO shaft

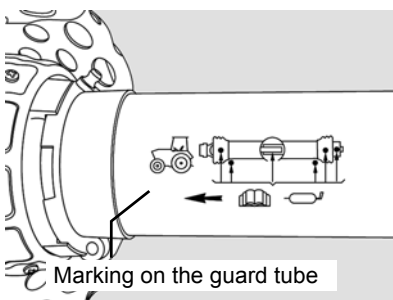

Make sure that you fit the PTO shaft in the correct installation position. There is a marking on the guard tube of the PTO shaft.

- ▶ Check the length of the PTO shaft and shorten it if necessary.
- ▶ Place the PTO shaft onto the PTO stub shaft of the machine.
- ▶ Secure the PTO shaft with a locking pin.

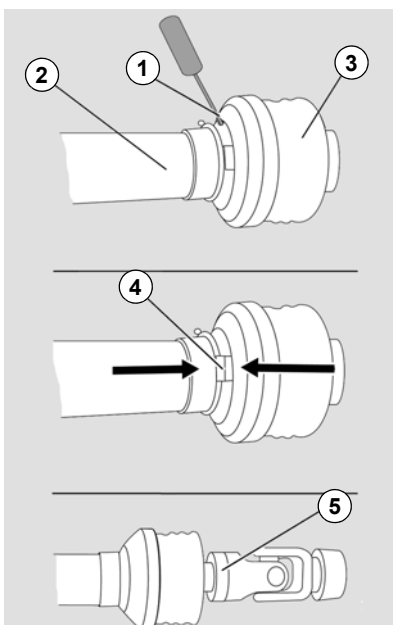

- ▶ Remove the locking screw (1) between the guard tube (2) and the guard cone (3).
- ▶ Twist the guard cone (3) and the guard tube (2) in opposite directions so that the "noses" of the slide ring (4) are positioned directly over the slots on the guard cone (3).
- ▶ Pull the guard cone (3) and guard tube (2) back until the single joint (5) is accessible.
- ▶ Connect the PTO shaft to the machine.
- ▶ Push the guard cone (3) and guard tube (2) back over the single joint (5).
- ▶ Tighten the locking screw (1).
- ▶ Secure the guard cone to the gear box using a jubilee clip.

Safety



! WARNING

Observe the safety information

Disregard for safety information can lead to serious or fatal injury. See chapter »Safety«, page 7.

Increased risk of injury

When the machine is being coupled to the tractor, there is an increased risk of injury. Therefore:

- Never stand between the tractor and machine.
- Secure the tractor against rolling away.

Failure to observe these instructions can result in serious or fatal injury.

General

The machine is equipped at the factory for coupling to the pending attachment or a lift link drawbar.

The following work steps are described in this section:

- »Coupling the machine«
- »Coupling the PTO shaft«
- »Connections«
- »Hydraulic connections«

Coupling the machine

Coupling the machine

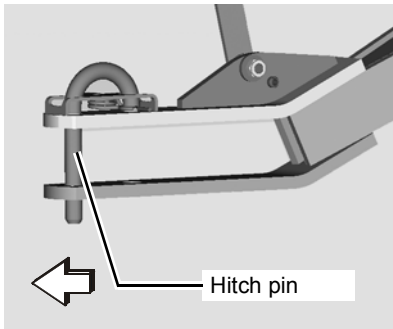

WARNING

Genuine hitch pins from the manufacturer

Use only genuine hitch pins from the manufacturer. These have the required strength. Other pins can break. The machine may be damaged or accidents caused as a result.

Avoid collisions

The PTO shaft and the drawbar must not collide with the lower link or any other part of the tractor when cornering or turning around. Fasten or remove the lower link and other parts outside of the collision range. Otherwise, damage to the machine or accidents may be caused as a result.

The rotary rake is coupled to the pending attachment or a lift link drawbar with a hitch pin and secured with a safety splint.

→ See »Coupling to the pending attachment«, page 37.

– or –

→ See »Coupling to the lift link drawbar«, page 38.



A freely turnable lift link drawbar is available as an optional accessory for coupling to lower links of category I-II.

→ See »Lift link drawbar«, page 83.

Coupling to the pending attachment

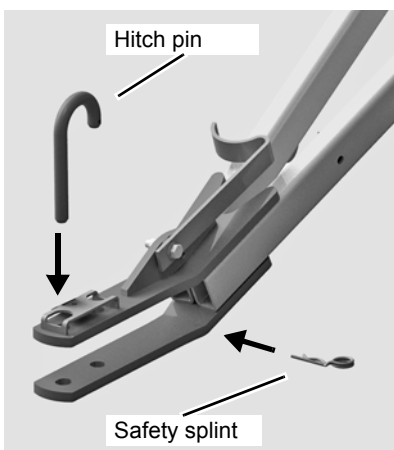
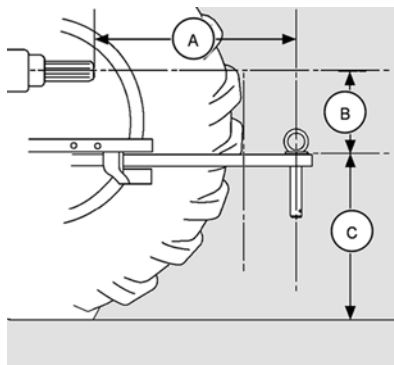
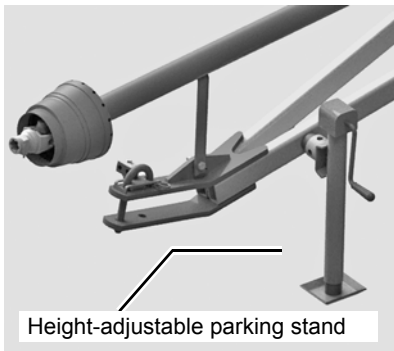

WARNING

Lock the height adjustment of the lower link

Lock the height adjustment of the lower link. Comply with the tractor operator's manual. Unintentionally raising the lower links can irreparably damage the PTO shaft.

Lock the lateral setting of the lower links

Fix the lower links after coupling the implement. Lateral free movement of the lower links causes unstable drive properties during transport journeys and can cause accidents.

For coupling to a pending attachment in accordance with ISO 6489-3, proceed as follows:

- ▶ (A) Distance between the PTO shaft drive and the drawbar hitching point: approximately 356 mm (14 in).
- ▶ (B) Height between the PTO shaft drive and the drawbar hitching point: approximately 203 – 305 mm (8 – 12 in).
- ▶ (C) Fix the lower link height at a distance of approximately 400 mm (15.75 in) from the ground.



- ▶ Shut off the engine, set the parking brake, remove the ignition key and secure the tractor against rolling away.
- ▶ Couple the rotary rake to the pending attachment with a hitch pin.
- ▶ Secure the hitch pin with a safety splint.
- ▶ Take the height-adjustable parking stand out of the transport holder bracket and fit it to the drawbar.
→ See »Coupling to the lift link drawbar«, page 38.



The working depth is adjusted on the chassis.

→ Chapter »Preparing for use«, section »Rotor pitch«, page 47.

Coupling the machine

Coupling to the lift link drawbar

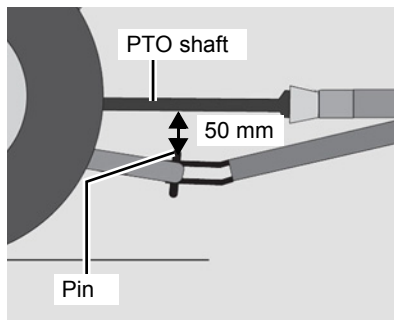

WARNING

Observe the minimum distance

In the work position, the distance between the PTO shaft and the pin must never be less than 50 mm (1.97 in). Otherwise the PTO shaft may be damaged, for example when driving over an undulation in the ground. Damaged PTO shafts can cause injury to persons or damage the machine.

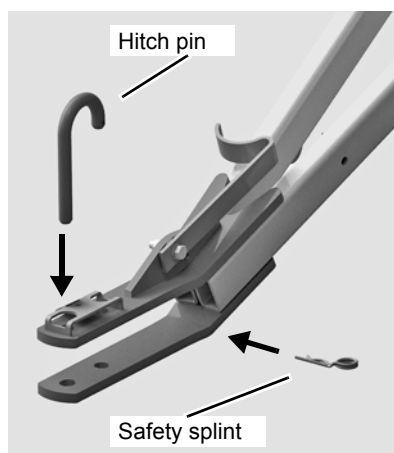

- ▶ Couple the rotary rake to the lift link drawbar with a hitch pin.
- ▶ Secure the hitch pin with a safety splint.
- ▶ Take the height-adjustable parking stand out of the transport holder bracket and fit it to the drawbar.
→ See »Coupling to the lift link drawbar«, page 38.

Stowing the height-adjustable parking stand

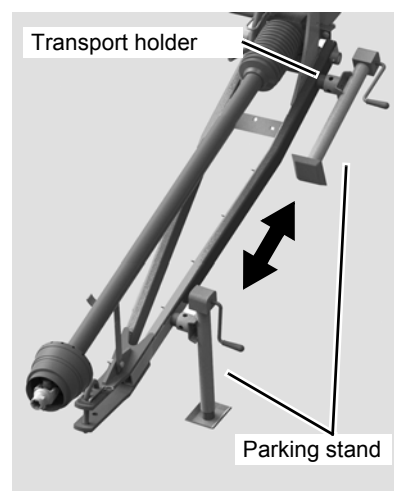

After coupling, remove the parking stand and fit and secure it to the transport holder.



- ▶ Shut off the engine, set the parking brake, remove the ignition key and secure the tractor against rolling away.
- ▶ Pull the pin on the parking stand.
- ▶ Remove the parking stand.
- ▶ Fit the parking stand to the transport holder and secure it with a hitch pin.

Safety chain

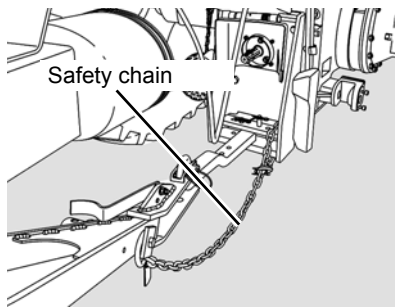

WARNING

Safety chain

When travelling on the road, always connect the machine and the tractor using a safety chain. Use a safety chain with a strength that corresponds to at least the total weight of the machine. Otherwise, serious or fatal injuries would be caused as a result.

- ▶ Fasten the supplied safety chain between the tractor and the machine.



Choose an appropriate length of chain so that the movement of the drawbar is not adversely affected and the chain does not hang down too low.



Also observe the national regulations regarding the length and fitting of safety chains.

Coupling the machine

Coupling the PTO shaft

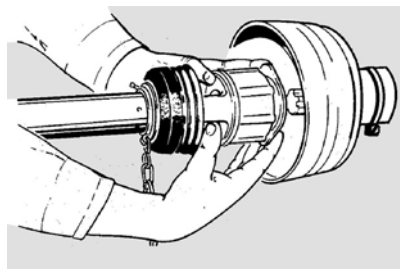
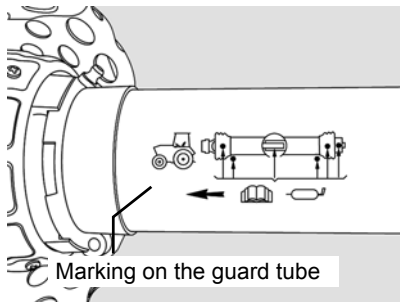
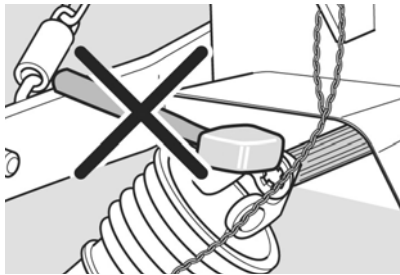

Make sure that you fit the PTO shaft in the correct installation position. There is a marking on the guard tube of the PTO shaft.



WARNING

Do not use force

When coupling the PTO shaft, do not use a hammer or any similar tools. Using these types of tool can severely damage the PTO shaft. A damaged PTO shaft can cause damage to the tractor and the machine.

- ▶ Check whether the PTO shaft must be shortened before coupling.
- ▶ Shorten the PTO shaft if necessary.
 - »Length of PTO shaft«, page 33
- ▶ Check that the tractor's PTO stub shaft is clean and lubricated.
- ▶ Couple the PTO shaft to the tractor and the machine.
 - Fit the wide-angle joint on the tractor side.
- ▶ Ensure that the PTO shaft is engaged on the shaft ends.
- ▶ Secure the guard tubes so that they cannot rotate at the same time.
- ▶ Couple the single joint with slip clutch to the machine's PTO stub shaft.

Connections

Electrical connections [+]

Lighting equipment – USA [+]

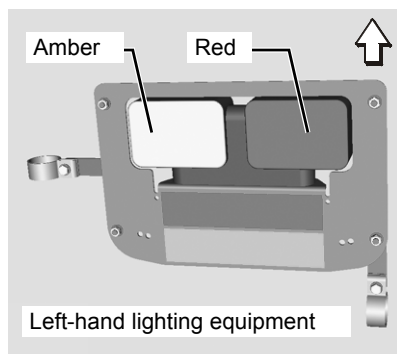

SAE J560 plug arrangement

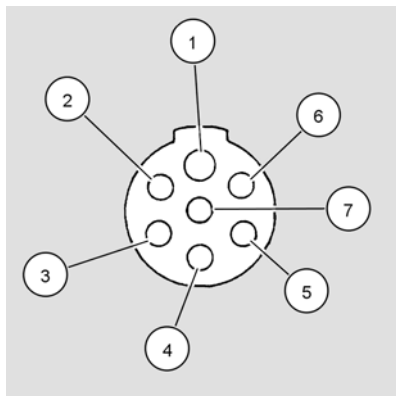

WARNING

Checking the electrical cables

Check the electrical cables. The electrical cables must not chafe or hang loose. Electrical cables that have been torn away or worn through must be replaced. Damage to the machine may be caused as a result.



If your tractor does not have the corresponding connection, this must be retrofitted. Consult your dealer.



The lighting equipment is controlled by the lighting controls in the tractor. The lights are only on if the tractor is in park position or the tractor's headlights are switched on.

PIN	Cable	Connection to
1	White	Grounding; all lights
2	Black	Not used
3	Yellow	Left amber flashing light
4	Red	Brake lights
5	Green	Right amber flashing light
6	Brown	Rear lights (red)
7	Blue	Not used

- ▶ Connect the plug for the 12 V power supply to the 7-pin plug socket on the tractor.

Coupling the machine

Function overview of lighting equipment – USA

- ▶ Check that the lighting equipment is functioning using the following table.

Tractor lights	Device lights			
	Left orange	Left red	Right red	Right orange
Headlight "OFF"	—	Off	Off	—
Headlight "ON"	—	Dimmed	Dimmed	—
Amber indicator light "OFF"	Off	—	—	Off
Amber indicator light "ON"	Flashing (same frequency as right)	—	—	Flashing (same frequency as left)
Brake lights (for tractors with brake lights)	—	Bright	Bright	—
Amber indicator light "ON" No turning indicated (tractor with brake lights)	Flashing (same frequency as right)	Bright	Bright	Flashing (same frequency as left)
Amber indicator light "ON" No turning indicated (no tractor brake lights)	Flashing (same frequency as right)	Off	Off	Flashing (same frequency as left)
Turning left indicated	Higher flashing frequency	Depending on tractor equipment: Off, dimmed or flashing in sync with the left-hand light	Off or dimmed	Illuminated, no flashing
Turning right indicated	Illuminated, no flashing	Off or dimmed	Depending on tractor equipment: Off, dimmed or flashing in sync with the right-hand light	Higher flashing frequency



Observe local regulations governing lighting equipment for travelling on the road. Consult your dealer if the lighting equipment does not function as stated.

Hydraulic connections



WARNING

Check hoses and couplings

Check all hydraulic hoses for damage before connecting them. Check all hydraulic couplings for firm seating after connecting them. Defective hydraulic hoses and poorly fitting hydraulic connections can trigger unanticipated movements in the machine, causing severe damage to the machine as well as personal injury. Serious or fatal injury may be caused as a result.

Secure the tractor's control devices

In the transport position, secure the control devices on the tractor against unintended actuation and lock them if possible. Unintentional activation of a control device can trigger unpredictable movements of the machine and cause serious machine damage and personal injury. Serious or fatal injury may be caused as a result.

Check the routing of the hydraulic hoses

Close or disconnect the quick couplings with great care. Remove any dirt or air which has entered the hydraulic system. The hydraulic system may otherwise be seriously damaged. Material damage or personal injury may be caused as a result.

Hydraulic connection at zero pressure only

Only connect hydraulic hoses to the tractor hydraulic system if the tractor and machine hydraulic system is at zero pressure. A hydraulic system which is under pressure can cause unforeseen movements on the machine.

Avoid mixing oils

If the machine is used on different tractors, an impermissible mixing of oil may occur. Impermissible oil mixtures can destroy tractor components.

High pressures in the hydraulic system

The hydraulic system is under high pressure. Regularly check all lines, hoses, and screwed connections for leaks and externally visible damage. Do not use hands to search for suspected leaks. Only use suitable equipment when looking for leaks. Rectify any damage immediately. Fluid escaping under pressure can penetrate skin may result in injuries and fires. Seek medical attention immediately if injuries occur.

Coupling the machine

Connecting the hydraulic couplings

WARNING

Make sure the connection is correct

Ensure that the hydraulic system is connected correctly, Otherwise, damage to the machine and personal injury may be caused as a result.

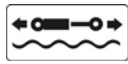

▶ Set the tractor hydraulics to floating position.



▶ Shut off the engine, set the parking brake, remove the ignition key and secure the tractor against rolling away.



▶ Close the ball valve.

▶ Connect the machine's hydraulic coupling to the single-acting hydraulic control device.

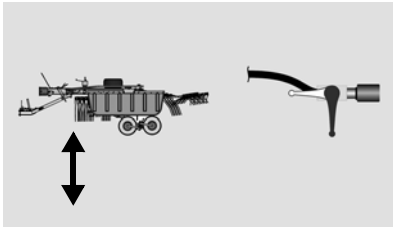

The following functions are carried out by hydraulic pressure on the feed line:



▶ Open the ball valve on the main frame (standard position).

- Transport position adjustable.
- Drawbar height adjustable.



▶ Close the ball valve on the main frame in transport position.

- Transport position fixed.
- Drawbar height adjustable.

Hydraulic line	Marking
Single-acting hydraulic control device pressure line	Black

Safety



WARNING

Observe the safety information

Disregard for safety information can lead to serious or fatal injury. See chapter »Safety«, page 7.

Securing the machine

Secure the machine against unintentional starting and rolling away. Use wheel chocks. The machine must stand on a level, firm and secure surface and be supported during the work, if necessary. Unsecured or non-supported machines can cause accidents. Otherwise, serious or fatal injury may be caused as a result.

No persons in the working area

Ensure that no persons are present in the slewing and working area of the machine. Persons could be caught by the machine within this area. This could result in fatal injury.

Remove tine supports

When carrying out adjustment work on the machine, tine supports which hinder work on the machine must be removed. Tine supports that are not removed can cause serious injuries.

Avoid the hazard area

The rotors are considered a hazard area. Do not stand in the hazard area. The rotors may lower or turn. This could result in fatal injury.

Preparing for use

General

The following applies when performing all adjustment work:

- ▶ Check the tire pressure.
- ▶ Secure the machine.
- ▶ Lower the machine to the work position.
- ▶ Undo the appropriate bolts.
- ▶ Make the required adjustment.
- ▶ Retighten the bolts.
- ▶ Fit and secure the tine supports.

The following work steps are described in this section:

- »Rotor pitch«
- »Working depth«

Adjusting the machine

The machine is preset at the factory. The following illustration shows an overview of the basic settings. Detailed information can be found on the following pages.

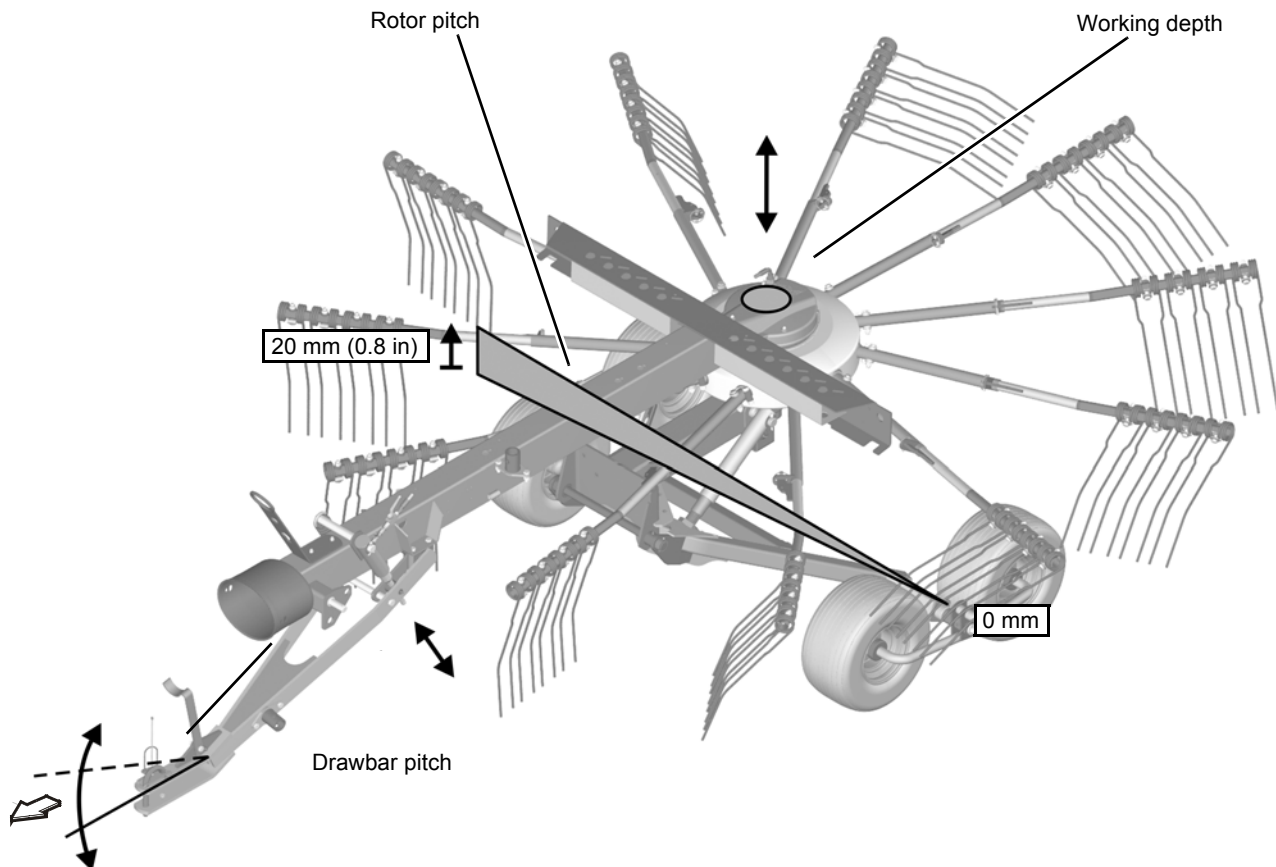

Rotor pitch

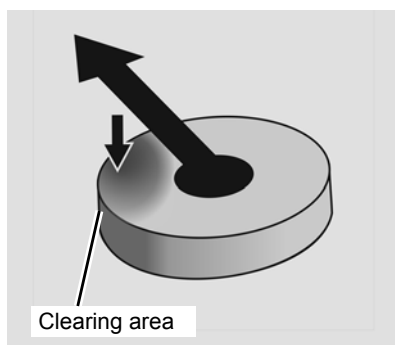

WARNING

Close the ball valve

Close the ball valve before working on the machine or carrying out any adjustment work. If the ball valve is open and there is an operating error, the machine can lower itself and cause serious injuries.

The rotor is inclined at an angle to the chassis so that the crop is picked up in the clearing area. The rotor is already inclined obliquely ex-factory. If the crop is not picked up cleanly, the raking quality can be improved by adjusting the rotor pitch.

The rotor pitch is adjusted as follows:



- ▶ Swing the machine into the headland position using the hydraulic control device in the tractor.
- ▶ Shut off the engine, set the parking brake, remove the ignition key and secure the tractor against rolling away
- ▶ Secure the rotors using supports.
- ▶ Remove the tine supports.



The optimum raking quality is achieved when the tines in the front working area and before the crop is deposited have the lowest possible ground clearance (see adjacent illustration).

Preparing for use

Adjusting the rotor pitch

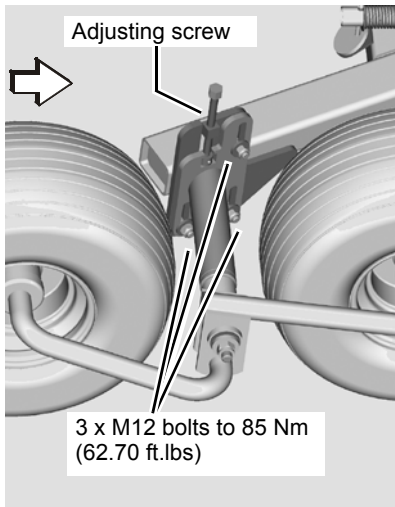

It is possible to adjust the position of the rotors laterally to the direction of travel.

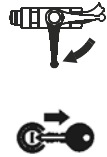

- ▶ Move the machine to the headland position using the tractor's control device.
- ▶ Close the ball valve.
- ▶ Shut off the engine, set the parking brake, remove the ignition key and secure the tractor against rolling away.
- ▶ Remove the tine supports via the wheel carrier.
- ▶ Slightly loosen the three bolts on the wheel carrier.
- ▶ Move the wheel carriers into the required position using the adjusting screw (see illustration below).
- ▶ Retighten the bolts to a tightening torque of 85 Nm (62.70 ft.lbs).
- ▶ Fit and secure the tine supports.

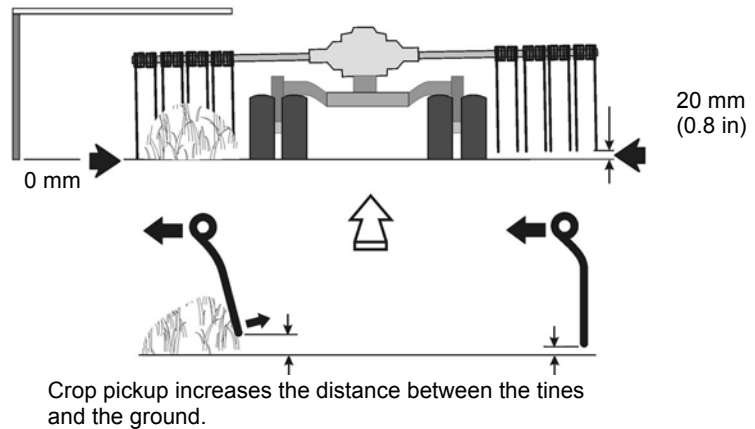

On the side opposite the swath former, the distance between the tines and the ground must be approximately 20 mm (0.8 in) greater than on the swathing side.

Working depth

When working, the machine is raised and lowered hydraulically. The machine is lowered as far as the preadjusted depth. The basic setting for the working depth is adjusted using an adjusting screw on the chassis cylinder.

WARNING

Never set the tines too deep

If the tines are set too deep:

- The tines are overstressed.
- The tines will soil the crop.
- This can result in damage to the machine.

Checking the working depth

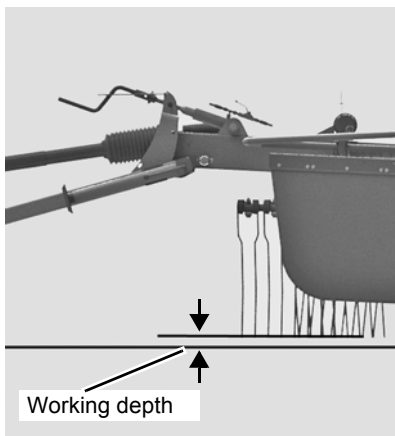

Check the preset working depth as follows:

- ▶ Fully lower the machine using the tractor's hydraulic control device.
- ▶ Shut off the engine, set the parking brake, remove the ignition key and secure the tractor against rolling away.
- ▶ Check the basic working depth setting:
 - The tips of the tines should lightly touch the ground in the clearing area when the height at the hitch is approx. 400 mm (15.8 in).



Tines that are set too low will soil the crop. The load on the rotor tines and the drive is increased.

- If necessary, adjust the working depth to the field again.

Preparing for use

Adjusting the working depth

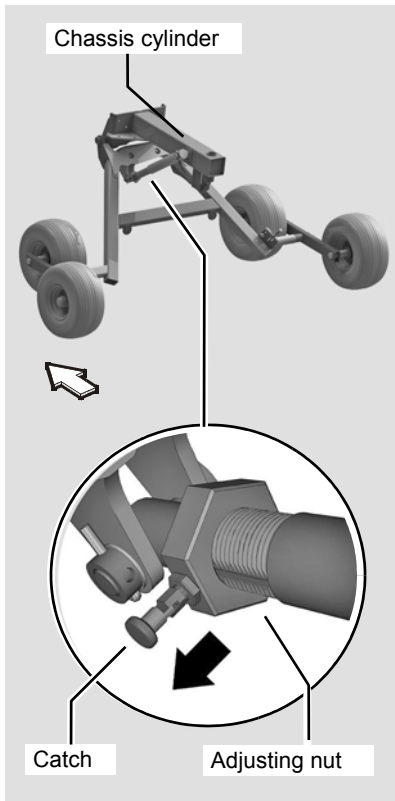

The chassis cylinder is used to adjust the chassis end stop in the work position. Start with a horizontal chassis basic setting at a hitch height of 400 mm (15.8 in). The chassis pitch depends on the ground conditions and the crop. Adjust the working depth as follows:

- ▶ Use the tractor's hydraulic control device to move the machine into the headland position.
- ▶ Shut off the engine, set the parking brake, remove the ignition key and secure the tractor against rolling away.
- ▶ Close the ball valve.
- ▶ Release the adjusting nut below the chassis using the catch and use the adjusting nut to adjust the working depth.
- ▶ Use the catch to prevent the adjusting nut from moving.
- ▶ Switch on the tractor.
- ▶ Lower the machine.
- ▶ Shut off the engine, set the parking brake, remove the ignition key and secure the tractor against rolling away.
- ▶ Check the working depth and readjust it if required.
 - The tips of the tines should lightly touch the ground in the clearing area when the height at the hitch is approx. 400 mm (15.8 in).



Two turns of the adjusting nut change the height by 15 mm on the tines

Adjusting the drawbar height

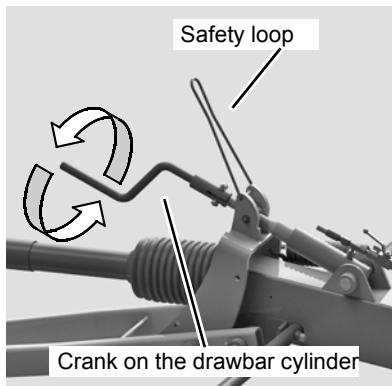

The drawbar cylinder is used to adjust the height of the drawbar and the machine pitch so that the crop can be picked up satisfactorily. Proceed as follows.

- ▶ Fold back the crank safety loop.
- ▶ Using the crank on the drawbar cylinder, adjust the draw shackle to a ground clearance of approximately 400 mm (15.8 in) .
- ▶ Re-secure the crank with the safety loop.



When using the optional support wheel, ensure that a lift of at least 10 mm (0.4 in) is guaranteed for the drawbar cylinder.

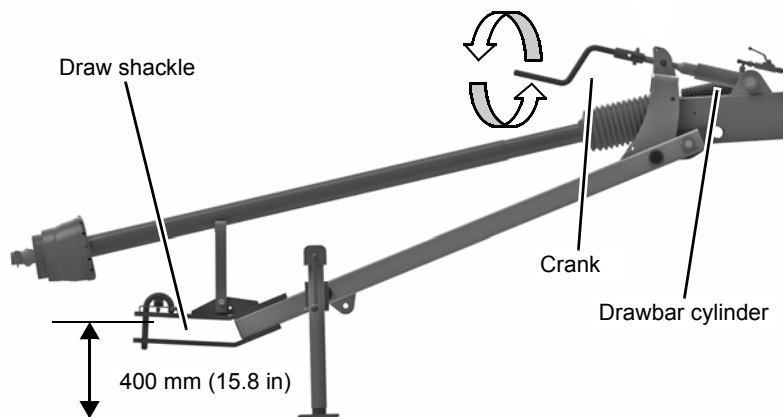

Preparing for use

Adjusting the support wheel [+]

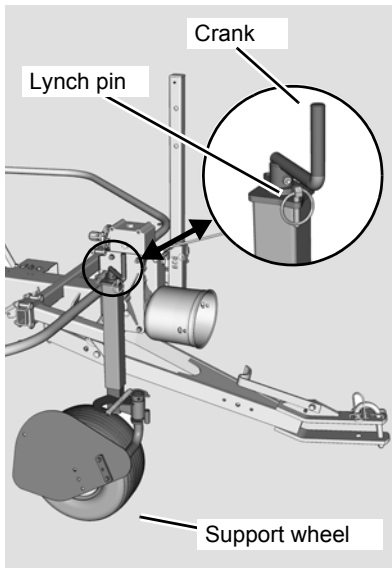

The raking quality is optimised through the interaction of the working depth and the optional support wheel. The machine is tilted forward or backwards using the support wheel. After adjusting the working depth, lower the machine:

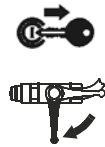

- ▶ Adjust the drawbar cylinder for using the optional support wheel.
→ See »Adjusting the drawbar height«, page 51.
- ▶ Use the tractor's hydraulic control device to lower the machine into the work position.
- ▶ Shut off the engine, set the parking brake, remove the ignition key and secure the tractor against rolling away.
- ▶ Close the ball valve.
- ▶ Release the lynch pin from the crank.
- ▶ Adjust the support wheel using the crank.
- ▶ Secure the crank with the lynch pin.

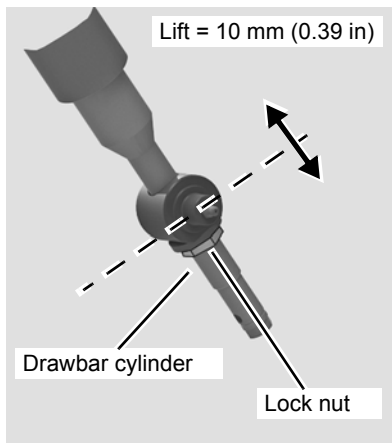

When the optionally available support wheel is used, the spindle on the drawbar cylinder must be adjusted to compensate for the ground undulations. Adjust the drawbar cylinder only when the load on the drawbar is relieved.

Operation with optional support wheel:

- ▶ Relieve the load on the drawbar using the optional support wheel.
- ▶ Undo the lock nut on the drawbar cylinder.
- ▶ Unscrew the spindle on the drawbar cylinder about 10 mm (0.4 in).
- ▶ Tighten the lock nut on the drawbar cylinder.



Spanner size "17" on the spindle



In the case of the optional support wheel, ensure that a lift of at least 10 mm is always guaranteed for the drawbar cylinder.

Safety

Before transporting the machine on public roads, please read the following safety information. Compliance is mandatory and will help you to avoid accidents.



WARNING

Observe the safety information

Disregard for safety information can lead to serious or fatal injury. See chapter »Safety«, page 7.

Ensuring road safety

The machine must conform to current national traffic regulations if you intend to drive it on public roads. Ensure the following:

- Lighting, warning and protective equipment must be fitted.
- The permissible transport widths and weights, axle loads, tire load-bearing capacities, laden weights and national speed restrictions must be observed.
- The maximum permissible road transport speed must be complied with, but not exceed 40 km/h (25 mph).
- The machine should only be towed by agricultural or forestry tractors.
- The empty weight of the tractor must be greater than the weight of the machine.

The driver and keeper of the vehicle are liable should these conditions not be observed.

Observe the contour of the terrain

Move the machine onto ground that is as flat as possible before changing from the working to the transport position. Avoid inclines on which the combination (tractor and machine) could slip or overturn. There is an increased risk of tipping and injury in a position at right angles to the direction of the slope.

Observe transport width

Observe the permissible transport widths. Put the machine in the transport position and attach lights, warning signs and protective equipment. The driver and keeper of the vehicle are liable for any non-compliance with national traffic regulations.

General

The following work steps are described in this section:

- »Prior to road transport«
- »Folding in the guard bar«
- »Folding the machine into the transport position«
- »Checking the machine«

Road transport

Prior to road transport

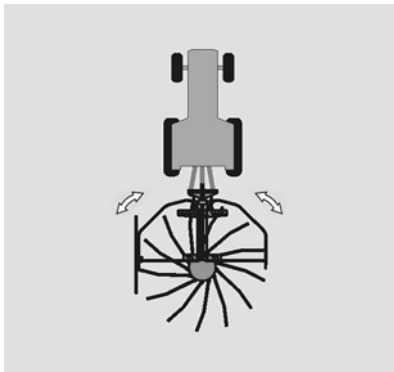

When driving on public roads, the machine must be in the transport position.

WARNING

Clean the machine before travelling on the road

Before any road transport, remove all coarse dirt, crop residues and clods of earth from the machine and clean it. Crops or dirt that drop onto the road can cause slippery road conditions. This could cause traffic accidents and accidents with fatal consequences.

Cleaning lighting equipment before travelling on the road

All lighting equipment must be cleaned before road transport. Crop residue or dirt may cover up the lighting equipment and adversely affect its correct operation. This could cause traffic accidents and other accidents with fatal consequences.

Prior to driving on public roads, the machine must be folded in, secured and moved into the transport position:

- ▶ Remove any crop and coarse dirt.
- ▶ »Moving the swath former to the transport position«
- ▶ »Folding in the guard bar«
- ▶ »Removing the tine supports«
- ▶ »Placing the tine supports in the transport holder«
- ▶ »Folding the machine into the transport position«
- ▶ »Checking the machine«

- ▶ Move the machine onto ground that is as flat as possible before changing from work to transport position.

Moving the swath former to the transport position

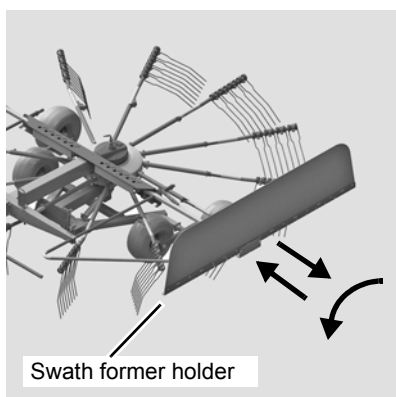

For the transport position with the lowest transport width, pull the swath former out of the holder, turn it 180° and push it fully back in and secure it.

The swath former consists of a board and a holder.

- ▶ In the work position, release the T-bolt from the swath former.
- ▶ Completely pull the swath former out of the holder.
- ▶ Turn the swath former 180° and push it back into the holder the other way round.
- ▶ Secure the swath former with the T-bolt.

Folding in the guard bar

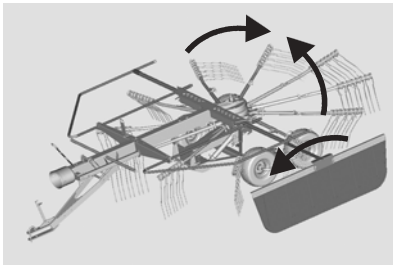

WARNING

No persons within the folding range

No persons may be present within the folding range and working area. Persons can be trapped by the machine. Serious or fatal injury may be caused as a result.

Fold in the guard bar as follows:

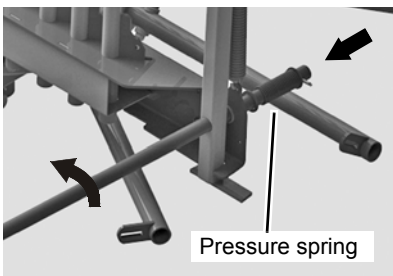

- ▶ Switch off the tractor PTO stub shaft drive.
- ▶ Lower the machine to the work position using the tractor's single-acting hydraulic control device.
- ▶ Shut off the engine, set the parking brake, remove the ignition key and secure the tractor against rolling away.
- ▶ Moving the swath former to the transport position.

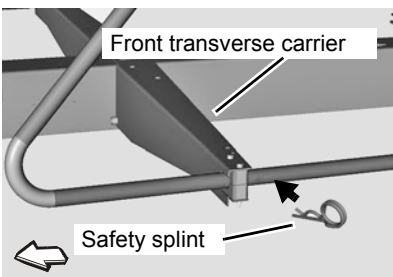

Left guard bar

- ▶ Pull the left guard bar with swath former forwards, against the resistance of the pressure spring, and fold upwards to 90°.
- ▶ Lock the guard bar in the vertical position.
- ▶ Secure the guard bar on the front support using a safety splint.

Right guard bar

- ▶ Pull the right guard bar forwards, against the resistance of the pressure spring, and fold upwards by 90°.
- ▶ Lock the guard bar in the vertical position.
- ▶ Secure the guard bar on the front support using a safety splint.

Road transport

Removing the tine supports

For road transport, all tine supports are removed and stowed in the transport holder. Exception: centre tine support for securing the rotor.

- ▶ Remove any crops and coarse dirt.
- ▶ Do not remove one of the tine supports and secure using a rotor securing device.

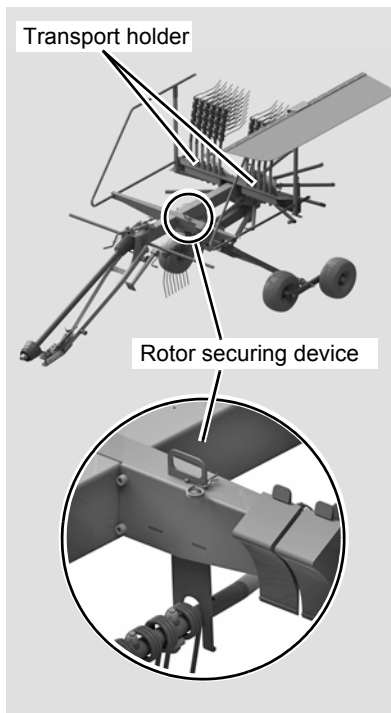

Placing the tine supports in the transport holder

- ▶ Loosen and remove the lynch pin from the tine support.
- ▶ Remove the tine supports from the rotor and secure them in the transport holder.
- ▶ Pull off the tine supports.

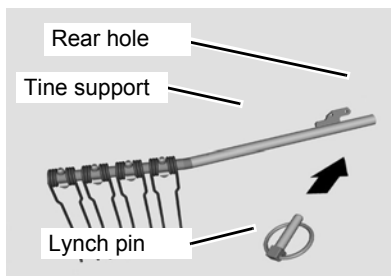

- ▶ Insert the tine support into the transport holder.
- ▶ Secure the tine support with a lynch pin.

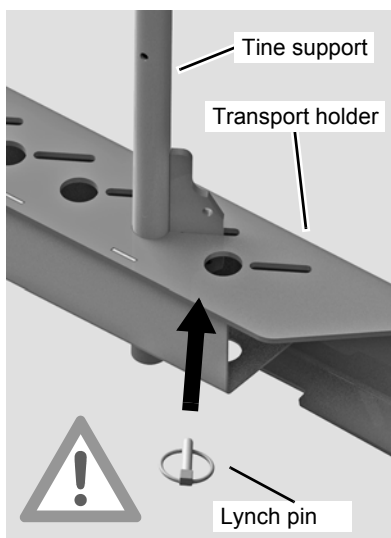

Securing the rotor

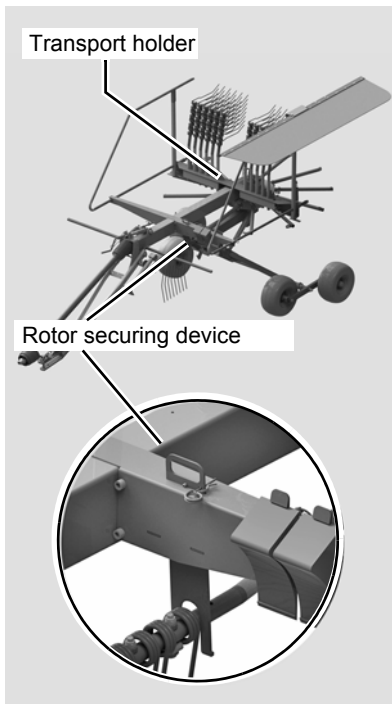

- ▶ Secure the rotor against turning using the rotor securing device.
- ▶ Secure the rotor securing device using a safety splint.

Folding the machine into the transport position

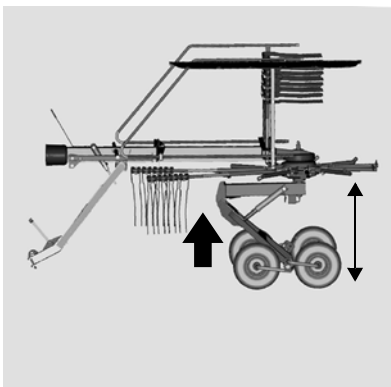

WARNING

Make sure the machine is standing level

Before changing from the transport to the work position (and vice versa), make sure the machine is standing level. The machine could tip over, particularly on hillside locations. Otherwise, damage to the machine and serious or fatal injury may be caused as a result.

No persons within the folding range

No persons may be present within the folding range and working area. Persons can be trapped by the machine. Serious or fatal injury may be caused as a result.

- ▶ Observe the instructions in »Prior to road transport«, page 54.
- ▶ Raise the rotor using the chassis hydraulics until the transport position is reached.



Do not raise the machine beyond the maximum permitted reflector height.

Road transport



WARNING

Follow the instructions below for road transport. This could cause traffic accidents and other accidents with fatal consequences.

- ▶ Before pulling away, check the immediate vicinity. Always make sure that you have a clear field of vision and, in particular, look out for children within the operating area of the machine.
- ▶ Lock the control devices on the tractor before driving on public roads.
- ▶ Do not transport people or objects on the machine.
- ▶ Adjust your speed to road conditions.
- ▶ Do not exceed a maximum speed of 40 km/h (25 mph). Comply with the national speed limits.
- ▶ Ensure sufficient steering and braking capability. Driving characteristics, steering, and braking capability are all influenced if the machine is coupled (increased braking distance as a result of greater inertia).

There is a danger of tipping on slopes and if corners are taken too fast.

Checking the machine

Prior to driving on the road, check the machine against the check list:



- PTO shaft drive off?
- Tire pressures correct?
- Crop residue and dirt removed?
- Guard bar folded?
- Tine supports in the transport holder and secured?
- Machine in transport position?
- Rotor secured?



- Ball valve closed?
- Lighting equipment in good working order?
- Safety chain attached?
- Lighting cables routed so that they are not strained and cannot become caught in the tractor's wheels when cornering?
- Hitch pins secured?
- Parking stand secured in the transport holder?
- Transport locking device for contact roller locked?

Safety

The following applies for all preparations on the field:

WARNING

Observe the safety information

Disregard for safety information can lead to serious or fatal injury. See chapter »Safety«, page 7.



Switch off the tractor and secure it

Before you dismount:

- ▶ Disengage the PTO
- ▶ Lower all implements to the ground
- ▶ Place all controls in their neutral or park position
- ▶ Set the parking brake
- ▶ Switch off the tractor.
- ▶ Remove the ignition key.
- ▶ Secure the tractor against rolling away.

An unsecured tractor can run you over or trap you. Otherwise, serious or fatal injury may be caused as a result.

Avoid the hazard area

The rotors are considered a hazard area. Do not stand in the hazard area. The rotors may lower or turn. Serious or fatal injury may be caused as a result.

Securing the machine

Secure the machine against unintentional starting and rolling away. Use wheel chocks. The machine must stand on a level, firm and secure surface and be supported during the work, if necessary. Unsecured or non-supported machines can cause accidents. Otherwise, serious or fatal injury may be caused as a result.

No persons in the working area

Ensure that no persons are present in the slewing and working area of the machine. Persons could be caught by the machine within this area. This could result in fatal injury.



Close the ball valve

Close the ball valve before adjusting. If the ball valve is open and there is an operating error, the machine may drop or swing out unexpectedly. This may cause damage to the machine or accidents with fatal consequences.

General

The following work steps are described in this section:

- »Fitting the tine supports«
- »Folding out the guard bars«
- »Adjusting the swath former«

Preparations on the field

Lowering the machine

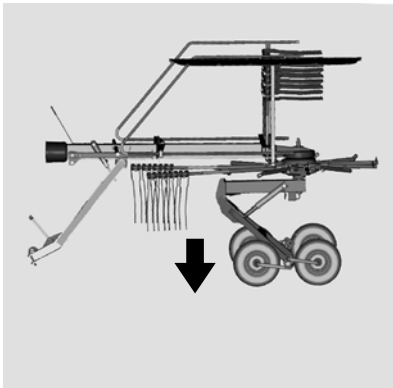

After road transport, the machine is brought into the work position on the field.



- ▶ Switch on the tractor.
- ▶ Lower the machine to the working position using the tractor's single-acting hydraulic control device.
- ▶ Shut off the engine, set the parking brake, remove the ignition key and secure the tractor against rolling away.

Fitting the tine supports

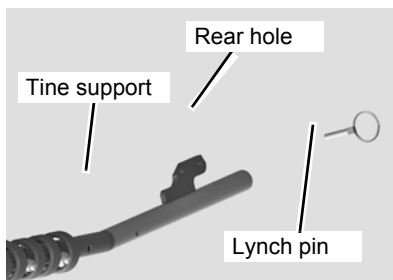

- ▶ Remove the tine supports from the transport holder.
- ▶ Attach the tine supports to the bushed bearing tube and secure with lynch pins.

Folding out the guard bars

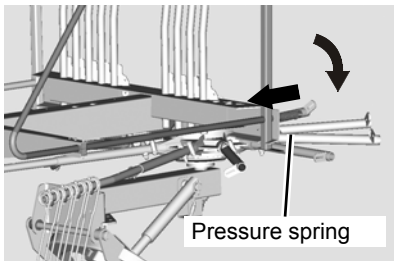
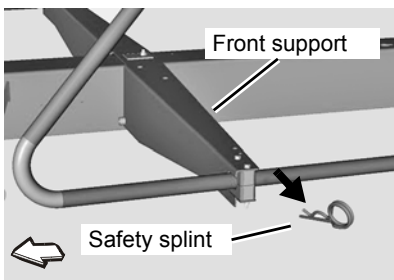
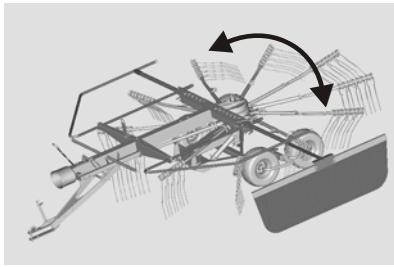

WARNING

No persons within the folding range

No persons may be present within the folding range and working area. There is an acute risk of injury within the folding range from machine parts which are slewing or folding. Serious or fatal injury may be caused as a result.

After the tines have been attached, all protective devices must be moved from transport to work position. Fold out the guard bar as follows:

Left guard bar

- ▶ Remove the safety splint from the front support.
- ▶ Pull the left guard bar with swath former forwards, against the resistance of the pressure spring, and fold downwards by 90°.

Right guard bar

- ▶ Remove the safety splint from the front support.

Pull the right guard bar forwards, against the resistance of the pressure spring, and fold downwards by 90°.

- ▶ Observe the instructions in chapter »Preparing for use«, section »Working depth« on page 49.

Preparations on the field

Adjusting the swath former

The swath former is pulled into the correct position and secured when changing from the transport to the work position.

For the work position, pull the swath former out of the holder, turn it 180° and push it fully back in and secure it.

Adjusting the swath width

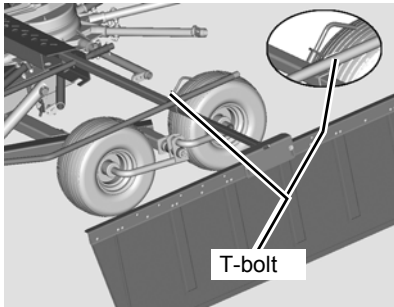

The swath width can be adjusted as follows:

- ▶ Loosen the T-bolt.
- ▶ Pull out the swath former to the desired width.
- ▶ Tighten the T-bolt in the new position and secure.

Adjusting the direction of travel

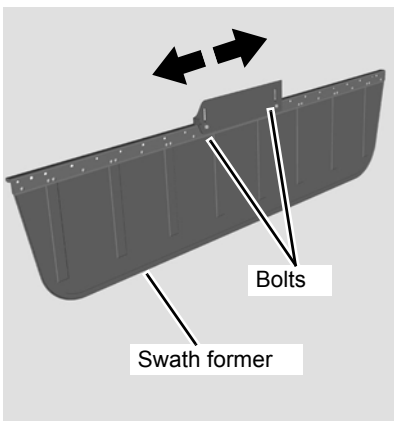

It is possible to adjust the direction of travel of the swath former as follows:

- ▶ Remove the bolts.
- ▶ Move the swath former into the desired position.
- ▶ Fit the bolts and tighten them in the new position.

Adjusting the swath former's height

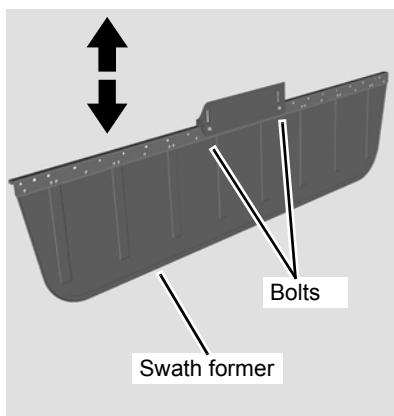

It is possible to adjust the height of the swath former as follows:

- ▶ Loosen the bolts.
- ▶ Adjust the height of the swath former.
- ▶ Tighten the bolts in the new position.

Safety



WARNING

Observe the safety information

Disregard for safety information can lead to serious or fatal injury. See chapter »Safety«, page 7.

No riding on the machine

Persons or objects must never be transported on the machine. Carrying passengers, especially children, on the machine is life threatening and prohibited. Serious or fatal injury may be caused as a result.

No persons in the working area

Ensure that no persons, especially children, are present in the slewing and working area of the machine. Persons could be caught by the machine within this area. This could result in fatal injury.

Maximum PTO speed 540 rpm

The PTO shaft speed must not exceed 540 rpm and must be adapted to the condition of the crop. Higher revolution rates can cause damage to the machine.

Only allow the PTO shaft clutch to respond for a short time

Do not allow the slip clutch to respond for longer than 3 seconds. If the clutch responds for a longer period of time, it will become worn and the disconnect torque will drop.

Do not compress the PTO shaft

The PTO shaft between the tractor and machine must not be compressed when in the work or transport position. If compressed, PTO shafts can cause damage to the machine and tractor.

Observe the contour of the terrain

Pay even more attention when driving on an incline. Avoid inclines on which the combination (tractor and machine) could slip or overturn. There is an increased risk of tipping and injury in a position at right angles to the direction of the slope.

Changes in the centre of gravity

When in work position, the machine's centre of gravity changes. Pay even more attention when driving on an incline. Avoid inclines on which the combination (tractor and machine) could slip or overturn. There is an increased risk of tipping and injury in a position at right angles to the direction of the slope.

Operation

General

The following work steps are described in this section:

- »Using the machine«
- »Driving on headlands«



Swath width

The swath width depends on the working width, working speed, rotor settings as well as crop condition.

Crop processing

The following methods of crop processing are possible with this machine:

- Single swath
- Night swath
- Swath turning
- Double swath
- Multiple swath

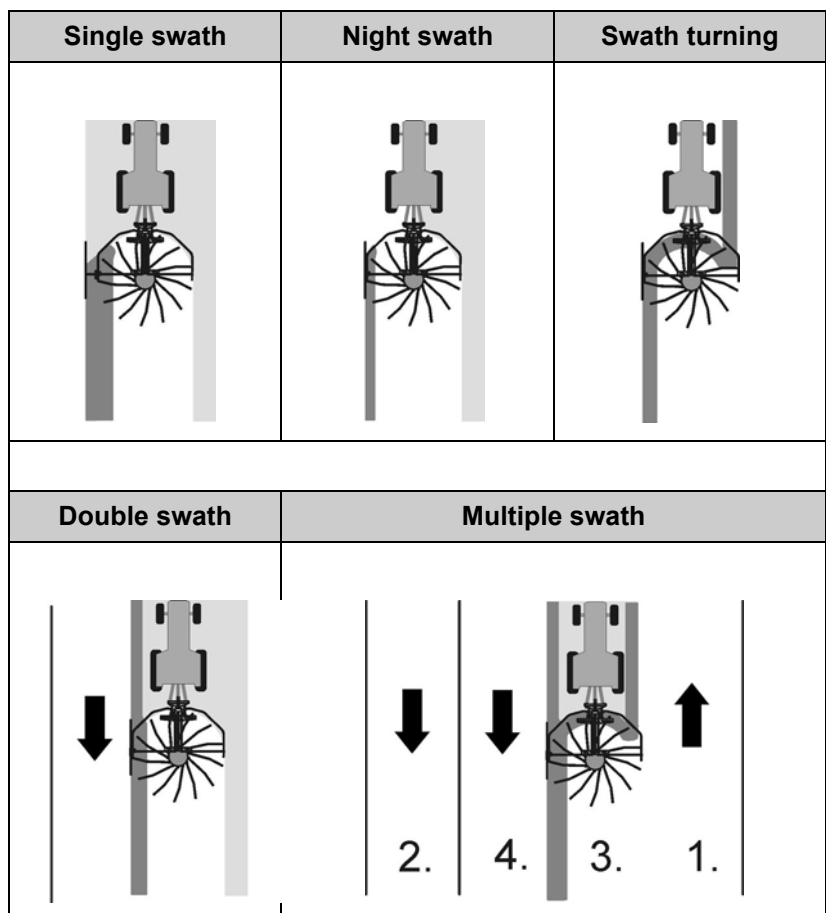

Using the machine

WARNING

No persons in the working area

Ensure that no persons, especially children, are present in the slewing and working area of the machine. Persons could be caught by the machine within this area. This could result in fatal injury.

Requirements

The machine is set correctly as follows:

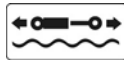

- Swath former adjusted.
- Tine supports are attached and secured.
- Rotor securing device on the rotor released.
- Tractor's lower links are set to the floating position.
- Machine in work position.

Start work as follows:



- ▶ Switch on the tractor.



- ▶ Open the ball valve.

- ▶ Check that there is nobody in the working area of the machine.

Switching on the PTO shaft drive

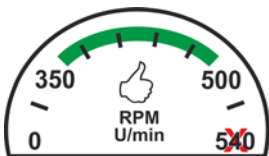

- ▶ Switch on the PTO shaft drive at a low engine speed.
- ▶ Slowly increase the speed. Do not exceed the maximum speed of 540 rpm.
- ▶ Select a driving speed at which the crop is picked up cleanly and distributed evenly.



- Start swathing at the edge of the field and at headlands to avoid subsequently driving over the crop.
- The slip clutch of the machine may also respond at low speed if resistance is increased due to excess crop or obstacles.
- Select PTO shaft speed depending on crop processing requirements.

Working speed



WARNING

Prevent crossing swathes

As a general measure, prevent the crossing of mowing swathes. The crop is distributed unevenly and the machine is subjected to abrupt stresses. Damage to the machine may be caused as a result.

Allow ample space when driving around obstacles

Obstacles must be circumnavigated in good time and at a distance. Due to the large width and length of the machine, it reacts slowly and tends to overrun. Damage to the machine may be caused as a result.

A constant working speed is essential for uniform crop processing. The working speed should be set between 4 and 12 km/h (between 2.5 and 7.5 mph) at which the crop is picked up cleanly and completely. The working speed depends on the machine settings, on ground and crop conditions.

- ▶ Select a working speed at which the crop is picked up cleanly and completely.

Driving on headlands

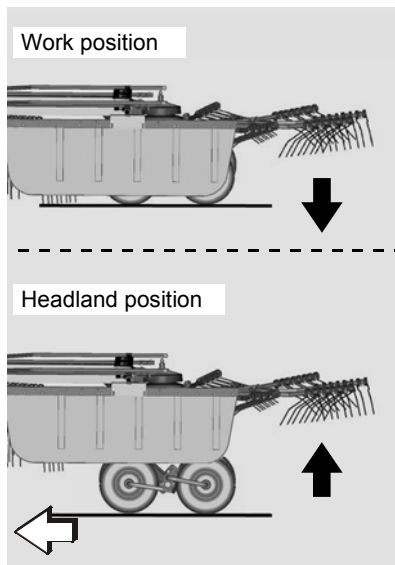

WARNING

Observe the contour of the terrain

Pay even more attention when driving on an incline. Avoid inclines on which the combination (tractor and machine) could slip or overturn. There is an increased risk of tipping and injury in a position at right angles to the direction of the slope.

Before raising, reduce the tractor speed and tine rotational speed

Before raising to the headland position, significantly reduce the speed and PTO stub shaft speed. Only raise the machine to the headland position so that the inner side devices are horizontal. Otherwise, damage to the machine may be caused as a result.

Observe the slewing range

The rear wheels of the tractor must not come into contact with the drawbar or the attachment carrier when cornering. This may happen when turning sharply. Unsuitable driving behaviour can cause serious damage.

Do not fully raise the machine

Do not fully raise the machine while in the headland. Otherwise, the machine may be damaged as a result.

The rotor can be raised for crossing swaths that have already been harvested.

Manoeuvring which involves tight turns on the field must only be performed at walking speed.



- ▶ Before raising, significantly reduce the speed and PTO stub shaft speed (≤ 4 km/h).
- ▶ Switch off the tractor PTO shaft drive.
- ▶ Raise the machine to the headland position using the tractor's single-acting hydraulic control device.
- ▶ Lower the machine again, in order to create a new swath.

Safety

The following applies to all cleaning and care work:



WARNING

Observe the safety information

Disregard for safety information can lead to serious or fatal injury. See chapter »Safety«, page 7.

Securing the machine



- Switch off the PTO shaft drive.
- Depressurise the hydraulic system.
- Whenever possible, uncouple the tractor.
- Place all controls in neutral or park.
- Set tractor parking brake.



- Switch off the tractor and remove the ignition key.
- Ensure the machine is standing on firm, secure and level ground, and provide additional support, if necessary.
- Secure the machine against rolling away (use wheel chocks).

Only if these regulations are observed can safe working be ensured during care and maintenance work. Unsecured or non-supported machines can cause accidents.

No persons in the working area

Ensure that no persons, especially children, are present in the slewing and working area of the machine. Persons could be caught by the machine within this area. This could result in fatal injury.

Do not clean bearings or hydraulic parts with high pressure cleaners

Do not clean bearings or hydraulic parts with high pressure cleaners. The high-pressure cleaner removes the grease film from the bare metal surfaces. Metal surfaces treated in this way can corrode. After each cleaning procedure, lubricate the bearing points and grease uncoated parts.

Clean the bearings and hydraulic parts with care

Exercise caution when cleaning with a high-pressure cleaner. Bearings, seals and pipe unions are not waterproof. In order to prevent damage to the machine, the bearings, seals and pipe unions must not be exposed to direct contact with the high pressure water jet.

General

The following work steps are described in this section:

- »Cleaning«
- »Care«

Cleaning



- ▶ Switch off the tractor PTO shaft drive.
- ▶ Use the tractor's hydraulic control device to fold the machine into its work position.
- ▶ Leave the machine coupled to the tractor.
- ▶ Lock the tractor's hydraulic control device.



- ▶ Shut off the engine, set the parking brake, remove the ignition key and secure the tractor against rolling away.
- ▶ Do not clean the bearings and piston rods of hydraulic cylinders using a high-pressure cleaner.
- ▶ After each use, clean the machine of any coarse dirt and crop residue.



- ▶ Cleaning with solvents may lead to corrosion.

After cleaning

- ▶ Lubricate all bearings after cleaning.
→ See chapter »Maintenance« and the following pages.
- ▶ Replace missing warning signs and DANGER, WARNING and CAUTION labels.

Care

For a long service life, we recommend the following:

- ▶ Apply a protective layer of oil to all uncoated work tools. Only use approved, biodegradable oil, e.g. rapeseed oil.
- ▶ Repair any paint damage.

Parking and storage

Safety

When setting down and parking the machine, special safety precautions have to be observed:



WARNING

Observe the safety information

Disregard for safety information can lead to serious or fatal injury. See chapter »Safety«, page 7.

Keep children away from the machine

Forbid children from playing on or around the machine. Select a parking area to which no unauthorised persons have direct access. Metal edges and machine work tools can cause serious injury.

Make sure the machine is standing level

Before changing from the transport to the work position (and vice versa), make sure the machine is standing level. The machine could roll away, particularly on hillside locations. Damage to the machine and serious or fatal injury may be caused as a result.

On uneven terrain, park in the work position only

Always park the machine in the work position on uneven terrain. Secure the machine against rolling away. Machines that are parked in the park position or transport position on uneven terrain could tip over. Damage to the machine and serious or fatal injury may be caused as a result.

Use wheel chocks

Never remove the wheel chocks before the machine has been coupled to the tractor. Persons could be run over by the machine or the tractor. Serious or fatal injury would be caused as a result.

General

The following work steps are described in this section.

- »Uncoupling the machine«

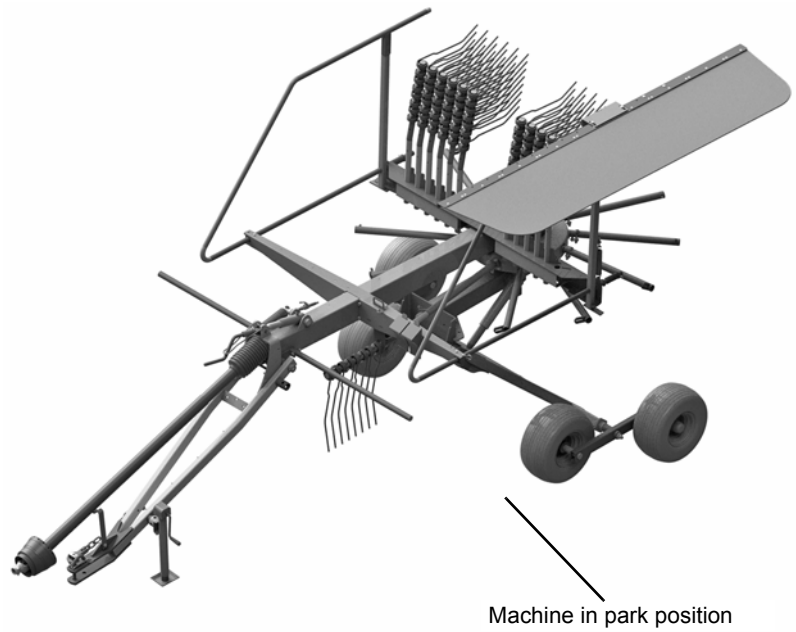

Machine in park position

Parking and storage

Uncoupling the machine

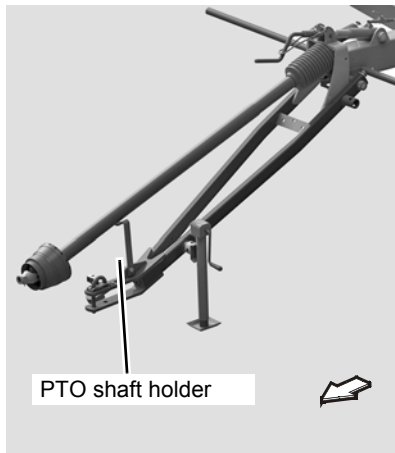

Uncoupling the machine is carried out in the reverse order to coupling the machine to the tractor. Proceed as follows:

→ Chapter »Coupling the machine«, page 35.

- ▶ Set the machine down on a firm, level surface and lower it to the work position.
- ▶ Shut off the engine, set the parking brake, remove the ignition key and secure the tractor against rolling away.
- ▶ Secure the machine against rolling away by using wheel chocks.
- ▶ Detach the PTO shaft, place it in the park position provided and secure it with the chain.
- ▶ Close ball valves.
- ▶ Release the hydraulic connections and insert them into the parking pockets on the machine.
- ▶ Disconnect the lighting plug and place it into the storage pocket on the machine.
- ▶ Wind the electrical cables onto the hook.
- ▶ Fasten the height-adjustable parking stand to the drawbar, secure it, and relieve the drawbar with the parking stand.
- ▶ Unhitch the machine.
- ▶ Switch on the tractor.
- ▶ Release tractor from machine.
- ▶ Drive tractor forward.
- ▶ Shut off the engine, set the parking brake, remove the ignition key and secure the tractor against rolling away.

After the end of the season

After the end of the season and if the machine is to be stored for a long period of time, perform the following work:

- ▶ Clean the machine thoroughly.
- ▶ Check all the screw joints and tighten the screws.
→ See »Tightening bolts«, page 77 for proper torque values.
- ▶ Repair or replace any damaged components.
- ▶ Repair any paint damage.
- ▶ Lubricate the machine in accordance with the lubrication schedule.
- ▶ Preserve the piston rods of the hydraulic cylinder.
- ▶ Check the tire pressure.
- ▶ Replace missing warning signs and DANGER, WARNING and CAUTION labels.

Safety

The following applies to all maintenance work:

WARNING

Observe the safety information

Disregard for safety information can lead to serious or fatal injury. See chapter »Safety«, page 7.

Requirements for maintenance work

Only perform the maintenance work if you have the required expert knowledge and suitable tools. A lack of technical knowledge or suitable tools can cause accidents and injuries.

Protect the machine against unintended starting

The following conditions must be observed for carrying out repairs and maintenance work and rectifying malfunctions on the machine when it is coupled:

- Switch off the PTO shaft drive.
- Place all controls in neutral or park.
- Set tractor parking brake.
- Shut off the engine, set the parking brake, remove the ignition key and secure the tractor against rolling away.
- Ensure the machine is standing on firm, secure and level ground, and provide additional support, if necessary.
- Secure the machine against rolling away (use wheel chocks).

Serious accidents may be caused if the machine starts unintentionally.

Use OEM replacement parts

Many components have special properties that are decisive for the stability and correct operation of the machine. Only spare parts and accessories supplied by the manufacturer have been tested and approved. Other products may adversely affect the correct operation of the machine and safety. The use of non-OEM replacement parts renders the manufacturer's guarantee null and void and frees the manufacturer from all liability.

Securing moving parts

Moving parts must be secured with lifting gear against sliding, folding or swivelling. Otherwise, serious injury to persons or damage to the machine may be caused as a result.

Disconnect electrical connections before performing welding work

Disconnect all electrical connections from the tractor when carrying out welding on the hitched machine. Otherwise, electrical and hydraulic systems will be damaged as a result.



Maintenance

Protective measures when handling oils or lubricants

Additives in oils and lubricants may have adverse effects on health. As marking in accordance with the hazardous goods regulation is not necessary, please always ensure the following:



WARNING

Avoiding skin contact

Avoid skin contact with these materials. Protect your skin by means of protective skin cream or oil-resistant gloves. Contact can result in skin damage.

Do not use oils for cleaning

Do not use oils or lubricants to clean your hands. Swarf and abraded material in these materials can also result in injuries.

Change out of soiled clothing

Change out of clothing that is heavily soiled with oil as soon as possible. Oils can be hazardous to your health.



- Used oil must be collected and disposed of.
- If the skin is damaged by oil or lubricant, seek medical advice immediately.

General

This information relates to general maintenance work. For all maintenance work, the machine must be locked in the work position. If the transport position is required for maintenance work, refer to the relevant instructions for the work.

- ▶ Lower the machine to the work position.
- ▶ Secure the machine against rolling away by using wheel chocks.

Direction information

Direction information (right, left, front, rear) is given in relation to the direction of travel. Rotary direction is defined as follows:

- Rotary direction right = clockwise.
- Rotary direction left = counterclockwise.
- Rotation about a vertical axis, viewed from top to bottom.
- Rotation about a horizontal axis, viewed at right angles to the direction of travel, from left to right.
- The rotation of bolts and nuts, etc. is always viewed from the operating side.

Maintenance terms

Listed in this table are short explanations of the most important maintenance terms.

Task	Explanation
Greasing	Apply grease to the slide surfaces using a brush.
Lubrication	One or two presses of the grease gun, unless specified otherwise.
Oiling	Unless specified otherwise, use only plant-based oils, such as rapeseed oils. The use of used oil will endanger your health and is also strictly prohibited.
Replacement	Replace the appropriate part in accordance with the instruction in the Maintenance chapter.
Inspection	Check the tire pressures, adjustment dimensions and seal tightness as required, and replace any worn parts or seals.
Observe the maintenance intervals	The specifications relate to an average usage of the machine. If subjected to heavier duty (e.g. by contracting companies), select the maintenance intervals to be shorter. Also, for extreme working conditions (for example heavy dust creation), shorter maintenance intervals are possible.

Lubricant

Gear Oil and Grease used on this machine has to meet the following requirements:

Lubricant	Specifications
Gear oil	SAE 90 API-GL-4 or 5
e.g.: KUBOTA HEAVY DUTY 80W-90 GEAR OIL	
Grease	NLGI GC/LB
e.g.: KUBOTA Polyurea Grease	

Maintenance

Maintenance intervals

	After 5 hours of operation	Daily	After 20 hours of operation	After 60 hours of operation	After 250 hours of operation	Once per season	After heavy use	As required	In case of wear	Lubrication	Greasing	Inspection	Replacement	Cleaning	Page
General															
All bolts	●					●		●							77
Visual inspection		●					●					●			
Bearing						●						●			78
Hose connections						●						●			
Air pressure		●				●		●				●			81
Lighting equipment								●				●		●	
Hydraulics															
Hydraulic hoses every 6 years													●		82
Hydraulic cylinders						●						●			
Hydraulic couplings						●						●			
PTO shafts															
Wide-angle joint				●		●				●					78
PTO shaft guard						●				●		●			80
Profile section tube						●					●				80
Gear box															
Rotor gear						●						●			81

Screwed connections

WARNING

Use original parts

Machine components have special properties that are essential for the stability and correct operation of the machine. Only spare parts and accessories supplied by the manufacturer have been tested and approved. Other products may adversely affect the correct operation of the machine and safety. The use of non-OEM replacement parts renders the manufacturer's guarantee null and void and frees the manufacturer from all liability.

On this machine, screws with a minimum quality of "8.8" (can be seen on the screw head) are used.

Tightening bolts

All bolts must be retightened:

- After the first 5 hours of operation.
- According to the frequency of use.
- At least once a season.

Screw and bolt tightening torques

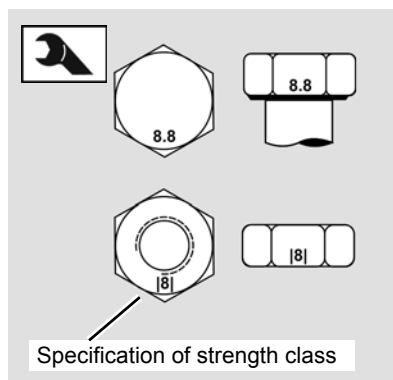

WARNING

Use the correct screw and bolt tightening torque

Securely tighten screws, nuts and bolts to the specified torques. Damage to the machine and serious or fatal injury may be caused as a result.

Note the strength class specification for screws, nuts and bolts. Refer to the table for the corresponding tightening torque. Securely tighten screws, nuts and bolts to the specified values, provided that no other value is specified. The torque specifications refer to a dry coefficient of friction (0.12).

	8.8	10.9	12.9
M 6	9.9 Nm (7.3 ft.lbs)	14 Nm (10.3 ft.lbs)	17 Nm (12.5 ft.lbs)
M 8	24 Nm (17.7 ft.lbs)	34 Nm (25 ft.lbs)	41 Nm (30.3 ft.lbs)
M 10	48 Nm (35.4 ft.lbs)	68 Nm (50.2 ft.lbs)	81 Nm (59.8 ft.lbs)
M 12	85 Nm (62.7 ft.lbs)	120 Nm (88.6 ft.lbs)	145 Nm (104 ft.lbs)
M 14	135 Nm (99.6 ft.lbs)	190 Nm (140 ft.lbs)	230 Nm (166 ft.lbs)
M 16	210 Nm (155 ft.lbs)	290 Nm (214 ft.lbs)	350 Nm (258 ft.lbs)
M 20	410 Nm (302 ft.lbs)	580 Nm (428 ft.lbs)	690 Nm (509 ft.lbs)



Tighten safety bolts and lock nuts to a 10% higher value.

Maintenance

Special tightening torques

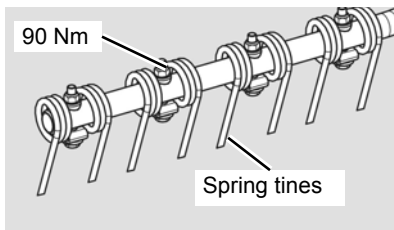

- 90 Nm (66.4 ft.lbs) spring tine.

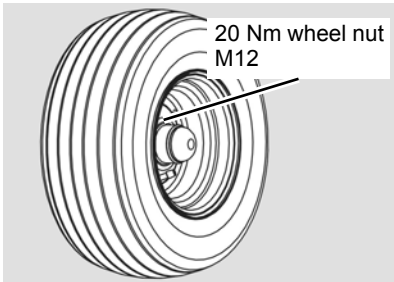

- 20 Nm (14.8 ft.lbs) Rotor chassis wheel nuts.



Tighten safety bolts and lock nuts to a 10% higher value.

Lubrication points for grease

Working with the brush

The points marked with a brush symbol should be regularly checked to ensure they move freely and lightly greased with the brush as required. Re-grease each time after cleaning.

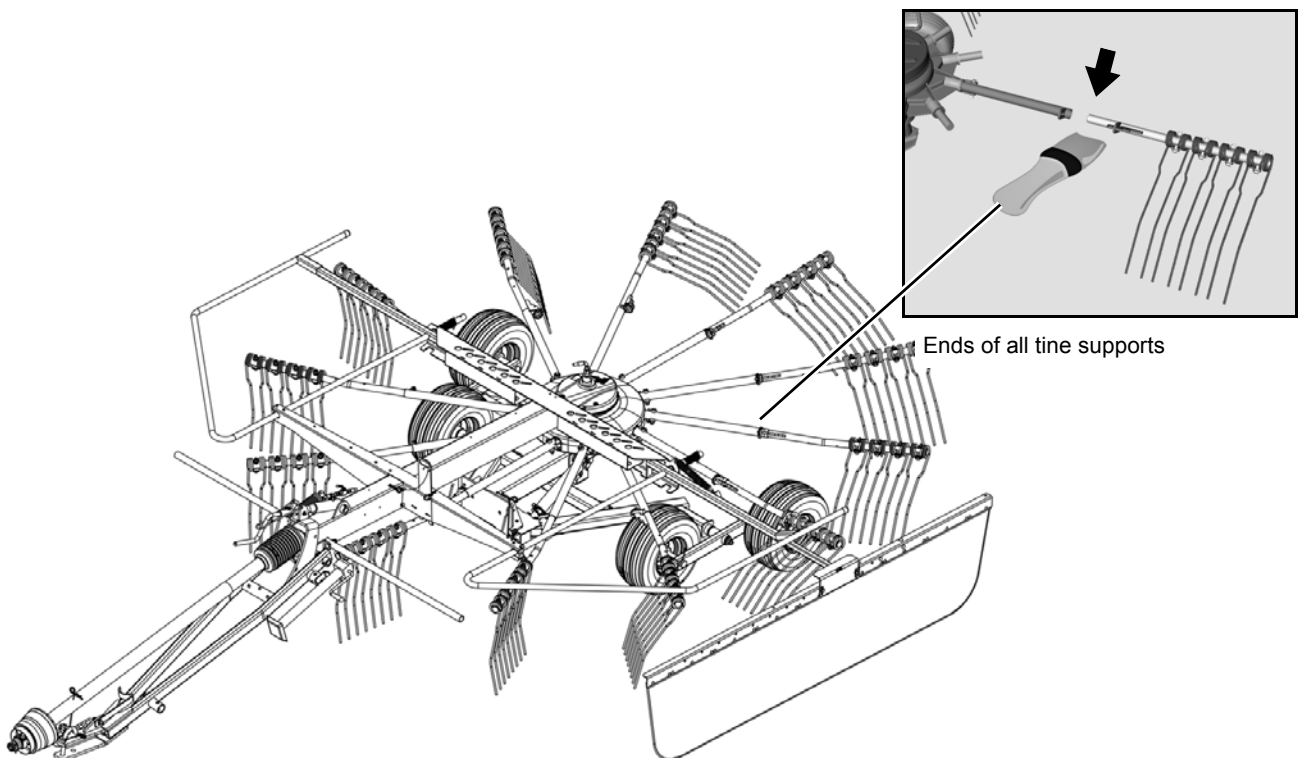

Working with a grease gun

Before applying the grease gun

- Clean grease fittings on the machine and gun fittings on the grease gun.

Lubricate the bearings with one or two presses of the grease gun. If you feel resistance at the second press, do not press a second time. Too much grease will force the bearings apart. This could allow dust and dirt to enter the bearing, resulting in premature wear.



Lubrication points are marked with an information label. If any labels are illegible or have been lost, it is possible to order new labels as replacement parts and affix them to the implement.

Lubricate the places listed in the illustration as follows:

- after 50 hours of operation.
- before and after the season.
- each time after cleaning with a high-pressure cleaner.

PTO shaft coupling

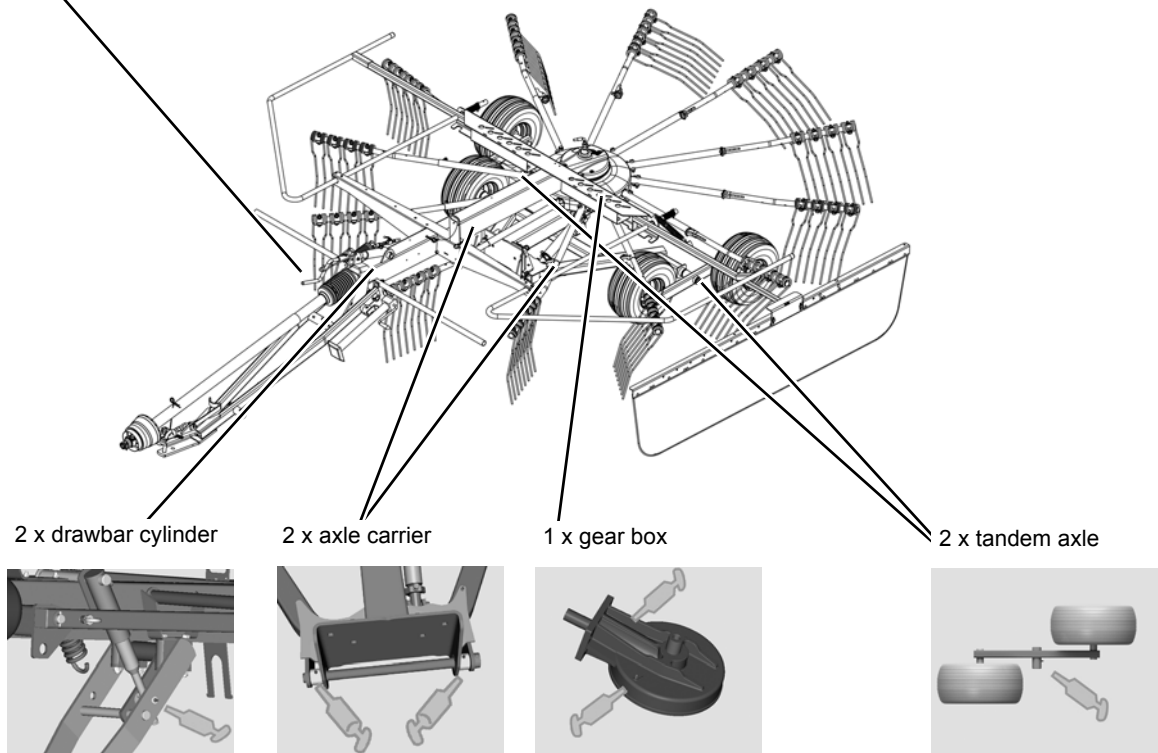

Maintenance

Lubricating the PTO shafts

The PTO shaft manufacturer's own operator's manual is included with each PTO shaft. This includes detailed information on the relevant version of the PTO shaft.

WARNING

Check the guard components

Check all guard components of the PTO shafts for wear or damage (visual inspection). Replace any defective guard components. An unguarded PTO shaft or damaged guard components can cause very serious injuries during operation.

Lubricate the single joints and their couplings as follows:

- after 60 hours of operation.
- before and after the season.
- each time after cleaning with a high-pressure cleaner.

Grease the profile section tubes:

- after 60 hours of operation.
- before and after the season.
- each time after cleaning with a high-pressure cleaner.

Lubricate the guard as follows:

- after 60 hours of operation.
- before and after the season.
- each time after cleaning with a high-pressure cleaner.

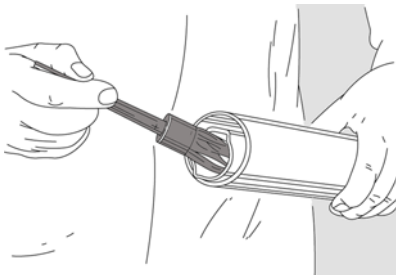

PTO shaft for the main drive

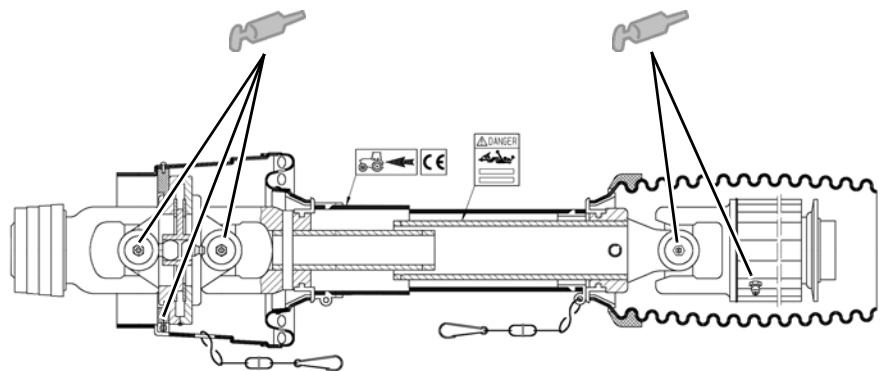

Filling quantities

CAUTION

Observe the correct fill quantities

Observe the correct lubricant fill quantities. Check them regularly. A lubricant level which is too low or too high may result in damage to the machine.

Gear box	Max. fill quantity [litres]
Rotor gear	6.2 l (6.55 US qt)

Checking rotor gear

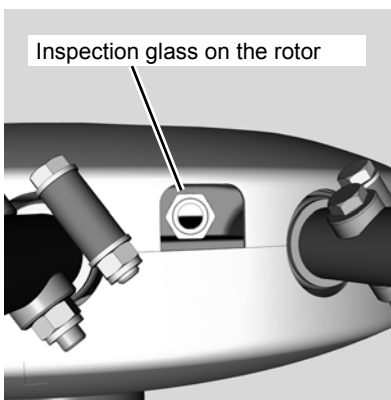

The rotor gear is equipped with a continuous oil lubrication system. Check the lubricants if there is visible loss of lubricant when the machine is in a horizontal position – at least once per season. If there is a visible loss of lubricant, consult your dealer. Otherwise, this will cause damage to the machine. The oil level at the rotor gear is indicated by an inspection glass.

- ▶ Check the oil level at the rotor using the inspection glass.
- ▶ If there is a visible loss of oil, top up to the required volume.

Tires

WARNING

Do not drive with worn or damaged tires

Replace worn or damaged tires immediately. There is a high risk of accident when driving on the road with such tires.

Tire pressure

Check the tire pressures on a regular basis:

- daily.
- before any road transport
- as required (for example before setting the tine height).
- before and after the season.

	Tire pressure
Rotor chassis	1,5 bar (22 PSI)

Hydraulics



WARNING

Hydraulic system at zero pressure

Work must only be performed on the hydraulic system if the tractor and machine hydraulic system is at zero pressure. A pressurised hydraulic system can trigger unforeseen movements on the machine and can cause serious machine damage and personal injury. Serious or fatal injury may be caused as a result.

Exercise caution when welding

Do not perform any welding work in the vicinity of the hydraulic hoses. Hydraulic oil can catch fire very easily.

Clean hydraulic system

Close or disconnect the quick couplings with great care. Remove any dirt or air which has entered the hydraulic system. The hydraulic system may otherwise be seriously damaged. Material damage or personal injury may be caused as a result.

Collect escaping oil

Escaping oil must be collected and disposed of in accordance with national regulations. Otherwise, damage may be caused to the environment.

Hydraulic hoses



WARNING

Replace hydraulic hoses every six years or earlier

Hydraulic hoses age without showing externally visible signs. Replace hydraulic hoses every six years, or earlier if aging or degradation is visible. Defective hydraulic lines can cause serious or fatal injuries.

Hydraulic hoses age without showing externally visible signs. We therefore recommend replacing the hydraulic hoses every six years.



- ▶ Lower the machine to the work position.
- ▶ Depressurise the system.
- ▶ Shut off the engine, set the parking brake, remove the ignition key and secure the tractor against rolling away.
- ▶ Disconnect the hydraulic hoses.
- ▶ Replace hydraulic hoses.

Optional additional equipment does not form part of the standard scope of delivery, and, in this manual, is indicated by a plus symbol [+]. Additional equipment is available to order from your dealer.

Tine saver

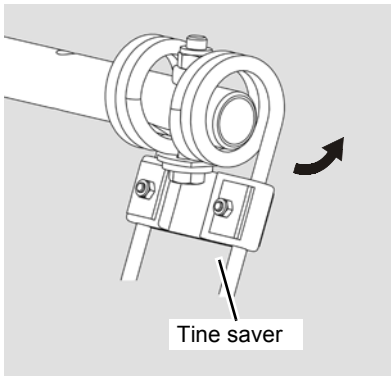

For a good swath deposit, both tine legs must run parallel to one another. This must also be ensured after fitting the tine saver.

Proceed as follows:

- ▶ Fit one tine saver on each tine.
- ▶ Check the direction of rotation of the rotor. The nuts must be attached against the rotor direction.
- ▶ Check the tine position. The tine legs must be parallel.
- ▶ If necessary, loosen the screwed connection until both tine legs run parallel.

Contact roller

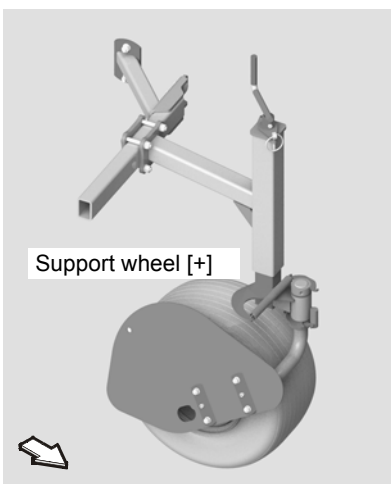

To ensure the machine offers even better contour guidance during operation, the manufacturer can also supply an optional contact roller.

The support wheel is fitted on the right. The option's scope of delivery includes two wheel chocks, which must be used when the machine is set down and parked.



When using the optional support wheel, ensure that a lift of at least 10 mm is guaranteed for the drawbar cylinder.

Lift link drawbar

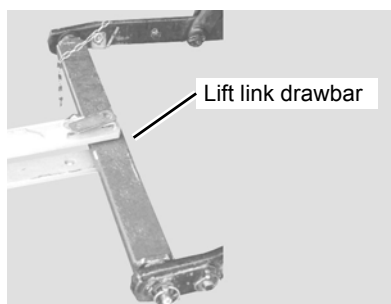

As a special accessory, there is a rotatable lift link drawbar for "category II".

Accessories

Lighting unit USA

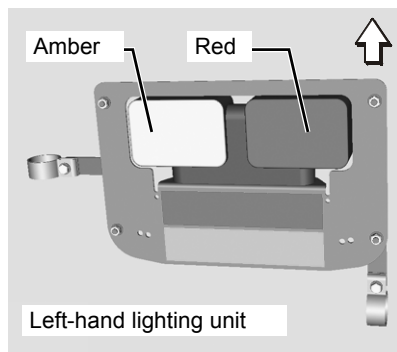

The optional kit increases safety when travelling on the road.

Spare wheel

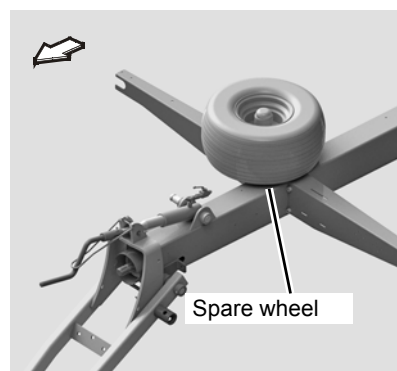

The optional spare wheel is mounted on the frame and can replace any one of the running wheels.

Troubleshooting

Faults can often be eliminated quickly and easily. Before contacting Customer Service, refer to the table to check whether you can remedy the fault yourself.

WARNING

In case of a fault, proceed as follows:

- ▶ Immediately stop operation.
- Switch off the PTO shaft drive.
- Place all controls in neutral or park.
- Set tractor parking brake.
- Shut off the engine, set the parking brake, remove the ignition key and secure the tractor against rolling away.
- Ensure the machine is standing on firm, secure and level ground, and provide additional support, if necessary.
- Secure the machine against rolling away (use wheel chocks).



The fault must be repaired before work can be resumed. Otherwise, damage to the machine and serious or fatal injury may be caused as a result.

Problem	Cause	Solution
Rotor is leaving crop behind on one side and is digging too deeply into the ground on the other side.	Incorrect adjustment of rotor pitch.	→ Chapter »Preparing for use«, section »Rotor pitch«, page 47
Rotor is leaving crop behind across the entire width.	Working depth set too high.	→ Chapter »Preparing for use«, section »Rotor pitch«, page 47
Crop is heavily contaminated.	Rotor tines set too low.	→ Chapter »Preparing for use«, section »Rotor pitch«, page 47
		→ Chapter »Coupling the machine«, section »Coupling the machine«, page 36
Machine not operating cleanly at high speed.	Rotor tines set too high. Uneven terrain.	→ Chapter »Preparing for use«, section »Rotor pitch«, page 47
	Speed too high to process crop mass	Reduce speed.
Rotor dragging crop along – Unclean swath form	Crop mass too large.	Reduce speed.
	Rotary speed too high.	Reduce speed.
PTO shaft coupling responding frequently.	Crop mass too large or uneven.	Reduce speed.
	Rotor tines set too low.	→ Chapter »Preparing for use«, section »Rotor pitch«, page 47
Noise production during work	Loose screwed connections or worn-out tine supports.	Check tine supports and screwed connections on tines.
	Tine support bent	

Fault elimination

Problem	Cause	Solution
Machine rolls offset behind the tractor when driving in a straight line.	Steering/tracking incorrectly adjusted or worn out.	Contact dealer.
Rotor not working cleanly.	Poor adaptation to the contours of the land due to severe rotor load relief	Please consult your dealer. You will find assistance under »Circuit diagrams«, page 87.

Hydraulic circuit diagram

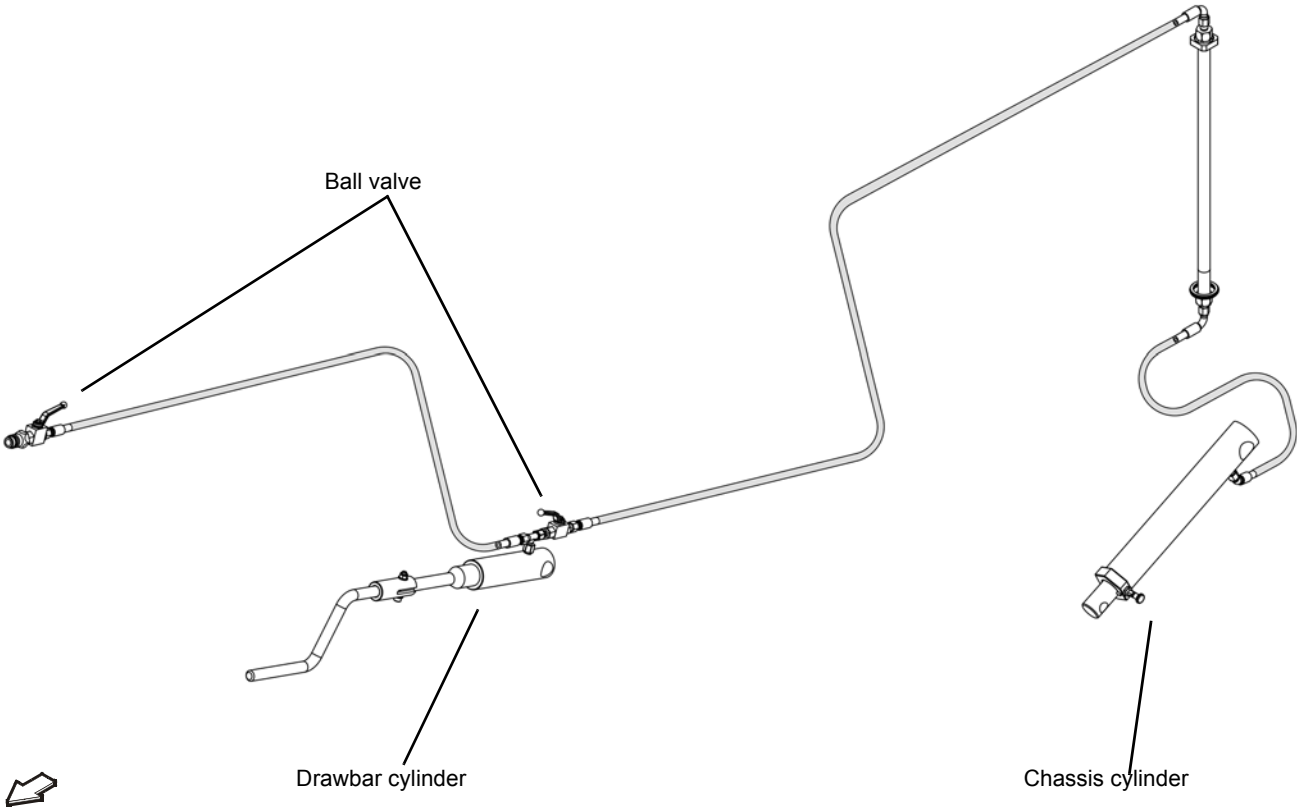

Circuit diagrams

Lighting equipment circuit diagram - USA

Wire Color Codes	
BK	Black
BR	Brown
DG	Dark Green
GR	Green
GR/BK	Green/Black
GY	Gray
OR	Orange
RD	Red
WH	White
YE	Yellow
YE/BK	Yellow/Black

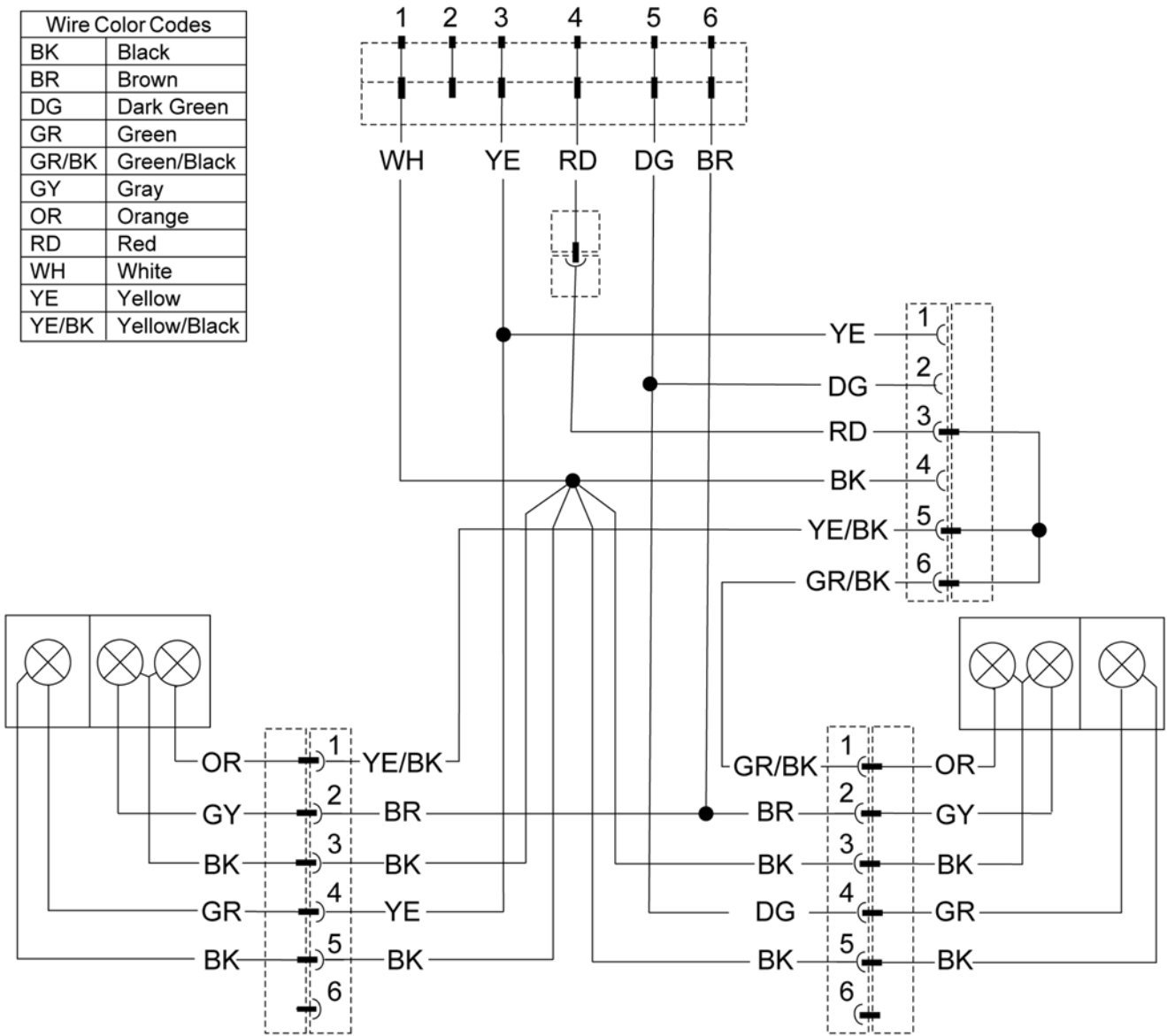

Disposal

During decommissioning, the individual parts must be disposed of properly and in an environmentally friendly manner. Please observe the waste disposal guidelines that are currently in force.

Plastic parts

Plastic parts can be disposed of in normal household waste (residual waste), depending on the laws specific to your country.

Metal parts

All metal parts can be sent for recycling.

Oil

In terms of waste legislation, environmentally-compatible hydraulic oils must be stored, collected and disposed of separately in accordance with regulations.

Rubber

Rubber parts, such as hoses or tires, must be brought to a rubber recycling centre.

EC Declaration of Conformity

**Conforms to
EC Directive
2006/42/EC**

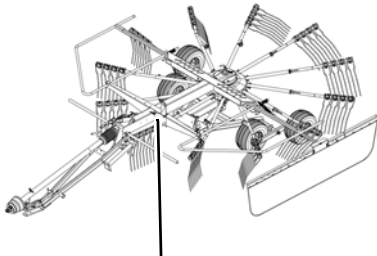

Type plate and CE marking

We

**Kverneland Group Kerteminde AS
Taarpstrandvej 25
DK-5300 Kerteminde
Denmark**

declare with sole responsibility that the product

**RA1047T
Andex 474 T
9447 T
SwatMaster 4732
and its accessories**

Model: VF6968

**Valid from machine number:
VF69680101 –**

to which this declaration relates, comply with the relevant basic health and safety requirements of EC Directive 2006/42/EC.

To demonstrate our compliance with the health and safety requirements quoted in the EC Directive, we make reference to the following standards:

- DIN EN ISO 12 100:2010
- DIN EN ISO 4254-1:2013
- DIN EN ISO 4254-10:2009 + AC:2010

Kverneland Group Kerteminde AS
Kerteminde, 31.03.2014

Uwe Kellermeier

EC authorised representative

A		Machine	78
Adjusting		PTO shafts	80
Chassis	47		
Rotor pitch	47		
Working depth	49		
Adjusting the drawbar cylinder	38		
C		M	
Care	69	Machine	
Check list		Putting away after the season	72
Road transport	58	Uncoupling	71
Checking the scope of delivery	31	Maintenance	73
Circuit diagram		Lubrication points	78
Hydraulics	87	Maintenance intervals	76
Lighting equipment	88	Maintenance terms	75
Cleaning	69	Screwed connections	77
Connecting the electrics	41		
Connecting the hydraulic couplings	44	O	
Connecting the hydraulics	43	Oil	
Coupling		Filling quantities	81
PTO shaft	40	Protective measures	74
Coupling to the lift link drawbar	37, 38	Operation	63
		P	
D		Preparation for road transport	
Declaration of Conformity	90	Transport position	54
Designation of components	26	Preparations on the field	59
Direction information	74	Work position	59
Disposal		Proper use	25
Metal parts	89	PTO shaft	
Plastic parts	89	Adapting the length	81
		Attaching	40
		Lubrication	80
		R	
E		Range of application	25
EC Declaration of Conformity	90	Road transport	53
		Tine supports in transport holder	56
		S	
F		Safety	8
Filling quantities	81	Care and maintenance	22
Fitting the tine supports	59	Pictorial symbols	10
		Road transport	19
		Uncoupling	21
G		Single-wheel rake	25
Guard bar		Speed	58
Folding out	61	Swath deposit	67
		Swath former	
		Adjusting the direction of travel	62
		Adjusting the height	62
H			
Height-adjustable parking stand	38		
L			
Lubrication points	78		

Index

T

Target group	4
Technical specifications	
Dimensions in transport position	27
Dimensions in work position	28
Machine equipment	30
Tractor equipment	29
Weights	29
Tightening torques	
Screwed connections	78
Spring tines	78
Wheel nuts	78
Tires	
Tire pressure	81
Tractors with quick-release couplings	36
Tractors without quick-release coupling	37