



- U.S.A. : **KUBOTA TRACTOR CORPORATION**
3401 Del Amo Blvd., Torrance, CA 90503, U.S.A.
Telephone : (310)370-3370
- Western Division : 1175 S. Guild Ave., Lodi, CA 95240
Telephone : (209)334-9910
- Central Division : 14855 FAA Blvd., Fort Worth, TX 76155
Telephone : (817)571-0900
- Northern Division : 6300 at One Kubota Way, Groveport, OH 43125
Telephone : (614)835-1100
- Southeast Division : 1025 Northbrook Parkway, Suwanee, GA 30024
Telephone : (770)995-8855
- Canada : **KUBOTA CANADA LTD.**
5900 14th Avenue, Markham, Ontario, L3S 4K4, Canada
Telephone : (905)294-7477
- France : **KUBOTA EUROPE S.A.S**
19-25, Rue Jules Verducruysse, Z.I. BP88, 95101 Argenteuil Cedex, France
Telephone : (33)1-3426-3434
- Italy : **KUBOTA EUROPE S.A.S Italy Branch**
Via Grandi, 29 20068 Peschiera Borrome (MI) Italy
Telephone : (39)02-51650377
- Germany : **KUBOTA (DEUTSCHLAND) GmbH**
Senefelder Str. 3-5 63110 Rodgau /Nieder-Roden, Germany
Telephone : (49)6106-873-0
- U.K. : **KUBOTA (U.K.) LTD.**
Dormer Road, Thame, Oxfordshire, OX9 3UN, U.K.
Telephone : (44)1844-214500
- Spain : **KUBOTA ESPAÑA S.A.**
Avenida Recomba No.5, Poligno Industrial la Laguna, Leganes, 28914 (Madrid) Spain
Telephone : (34)91-508-6442
- Australia : **KUBOTA TRACTOR AUSTRALIA PTY LTD.**
25-29 Permas Way, Truganina, VIC 3029, Australia
Telephone : (61)-3-9394-4400
- Malaysia : **SIME KUBOTA SDN. BHD.**
No.3 Jalan Sepadu 25/123 Taman Perindustrian Axis,
Seksyen 25, 40400 Shah Alam, Selangor Darul Ehsan Malaysia
Telephone : (60)3-736-1388
- Philippines : **KUBOTA PHILIPPINES, INC.**
232 Quirino Highway, Baesa, Quezon City 1106, Philippines
Telephone : (63)2-422-3500
- Taiwan : **SHIN TAIWAN AGRICULTURAL MACHINERY CO., LTD.**
16, Fengping 2nd Rd, Taliaw Shiang Kaohsiung 83107, Taiwan R.O.C.
Telephone : (886)7-702-2333
- Indonesia : **PT KUBOTA MACHINERY INDONESIA**
Tower A at EightyEight@Kasablanka Lantai 16
Jalan Raya Casablanka Kav. 88, Jakarta 12870 Indonesia
Telephone : (62)-21-29568-720
- Thailand : **SIAM KUBOTA CORPORATION CO., LTD.**
101/19-24 Moo 20, Navanakorn Industrial Estate, Tambon Khlongnueng, Amphur Khlongluang,
Pathumthani 12120, THAILAND
Telephone : (66)2-909-0300
- Korea : **KUBOTA KOREA CO., LTD.**
41-27, Jayumuyeok-gil, Baeksan-myeon, Gimje-si, Jeollabuk-do, Korea
Telephone : (82)-63-544-5822
- India : **KUBOTA AGRICULTURAL MACHINERY INDIA PVT. LTD.**
No.15, Medavakkam Road, Sholinganallur, Chennai-600119, T.N., India
Telephone : (91)44-6104-1500
- Vietnam : **KUBOTA VIETNAM CO., LTD.**
Lot B-3A2-CN, My Phuoc 3 Industrial Park, Ben Cat District, Binh Duong Province, Vietnam
Telephone : (84)-650-3577-507

KUBOTA Corporation

English (U.S.A.)
Code No. 3B881-9971-2

OPERATOR'S MANUAL

KUBOTA TRACTOR

**MODELS M4N-071
M5N-091
M5N-111**



1AGBDABAP123A



1AGBDABAP070A

M
4
N
·
0
7
1
·
M
5
N
·
0
9
1
·
M
5
N
·
1
1
1

READ AND SAVE THIS MANUAL



ABBREVIATION LIST

Abbreviations	Definitions
2WD	2 Wheel Drive
4WD	4 Wheel Drive
API	American Petroleum Institute
ASABE	American Society of Agricultural and Biological Engineers, USA
ASTM	American Society for Testing and Materials, USA
DIN	Deutsches Institut für Normung, GERMANY
DEF	Diesel Exhaust Fluid
DPF	Diesel Particulate Filter
DT	Dual Traction [4WD]
fpm	Feet Per Minute
GST	Glide Shift Transmission
Hi-Lo	High Speed-Low Speed
HST	Hydrostatic Transmission
m/s	Meters Per Second
PTO	Power Take Off
RH/LH	Right-hand and left-hand sides are determined by facing in the direction of forward travel
ROPS	Roll-Over Protective Structures
rpm	Revolutions Per Minute
r/s	Revolutions Per Second
SAE	Society of Automotive Engineers, USA
SCR	Selective Catalytic Reduction
SMV	Slow Moving Vehicle

KUBOTA Corporation is ...

Since its inception in 1890, KUBOTA Corporation has grown to rank as one of the major firms in Japan.

To achieve this status, the company has through the years diversified the range of its products and services to a remarkable extent. 30 plants and 35,000 employees produce over 1,000 different items, large and small.

All these products and all the services which accompany them, however, are unified by one central commitment. KUBOTA makes products which, taken on a national scale, are basic necessities. Products which are indispensable. Products which are intended to help individuals and nations fulfill the potential inherent in their environment. KUBOTA is the Basic Necessities Giant.

This potential includes water supply, food from the soil and from the sea, industrial development, architecture and construction, and transportation.

Thousands of people depend on KUBOTA's know-how, technology, experience and customer service. You too can depend on KUBOTA.

California Proposition 65









▲ WARNING ▲

Engine exhaust, some of its constituents, certain vehicle components and fluids, contain or emit chemicals known to the State of California to cause cancer and birth defects or other reproductive harm.















UNIVERSAL SYMBOLS

















As a guide to the operation of your tractor, various universal symbols have been utilized on the instruments and controls. The symbols are shown below with an indication of their meaning.

■ General







-  Safety Alert Symbol
-  Master System Warning
-  Fast
-  Slow
-  Creep
-  Lock
-  ON (Engaged)
-  OFF (Disengaged)







■ Engine-related

-  Diesel Fuel
-  Empty
-  Full
-  Hourmeter/Elapsed Operating Hours
-  Engine Coolant-Temperature
-  Low Temperature Regulation
-  Engine Intake/Combustion Air-Filter
-  Engine Oil-Pressure
-  Water Separator
-  Engine-Warning
-  Engine-Rotational Speed
-  Engine-Rev Limiter
-  Engine-Constant RPM management
-  Engine-Over Speed







-  Engine-RPM Increase
-  Engine-Run
-  Engine-Start
-  Engine-Stop
-  Electrical Power-accessories
-  Diesel Preheat/Glow Plugs (Low Temperature Start Aid)
-  Emission Control
-  Regeneration
-  Regeneration inhibit
-  Regeneration (Switch)
-  Parked Regeneration
-  DEF/AdBlue®-Level
-  DEF/AdBlue®-Low Level
-  DEF/AdBlue®-Poor Quality
-  DEF/AdBlue®-Trouble
-  DEF/AdBlue®-Thawing

■ Vehicle body-related

-  4-Wheel Drive-On
-  4-Wheel Drive-Off
-  4-Wheel Drive-On
-  Bi-Speed turn
-  Clutch
-  Brake
-  Parking Brake

-  Differential Lock
-  Steering Wheel-Tilt
-  PTO-Off (Disengaged)
-  PTO-On (Engaged)
-  PTO-540 rpm
-  PTO-540E rpm
-  PTO-1000 rpm

■ Hydraulic-related

-  Draft Control-Shallow Position
-  Draft Control-Deep Position
-  Position Control-Raised Position
-  Position Control-Lowered Position
-  3-Point Lowering Speed Control
-  Remote Cylinder-Retract
-  Remote Cylinder-Extend

■ Electric-related

-  Battery Charging Condition
-  Headlight-Low Beam
-  Headlight-High Beam
-  Turn Signal
-  Hazard Warning Lights
-  Audible Warning Device
-  Windshield Wiper
-  Windshield Wiper-Intermittent
-  Windshield Washer
-  Rear Window Defroster

FOREWORD

You are now the proud owner of a KUBOTA Tractor. This tractor is a product of KUBOTA quality engineering and manufacturing. It is made of fine materials and under a rigid quality control system. It will give you long, satisfactory service. To obtain the best use of your tractor, please read this manual carefully. It will help you become familiar with the operation of the tractor and contains many helpful hints about tractor maintenance. It is KUBOTA's policy to utilize as quickly as possible every advance in our research. The immediate use of new techniques in the manufacture of products may cause some small parts of this manual to be outdated. KUBOTA distributors and dealers will have the most up-to-date information. Please do not hesitate to consult with them.



SAFETY FIRST

This symbol, the industry's "Safety Alert Symbol", is used throughout this manual and on labels on the machine itself to warn of the possibility of personal injury. Read these instructions carefully. It is essential that you read the instructions and safety regulations before you attempt to assemble or use this unit.



DANGER : Indicates an imminently hazardous situation which, if not avoided, will result in death or serious injury.



WARNING : Indicates a potentially hazardous situation which, if not avoided, could result in death or serious injury.



CAUTION : Indicates a potentially hazardous situation which, if not avoided, could result in minor or moderate injury.

IMPORTANT : Indicates that equipment or property damage could result if instructions are not followed.

NOTE : Gives helpful information.

CONTENTS

▲ SAFE OPERATION	▲ -1
SERVICING OF TRACTOR.....	1
SPECIFICATIONS.....	3
SPECIFICATION TABLE	3
TRAVELING SPEEDS	5
IMPLEMENT LIMITATIONS	7
INSTRUMENT PANEL AND CONTROLS.....	9
INSTRUMENT PANEL, SWITCHES AND HAND CONTROLS	9
FOOT AND HAND CONTROLS	11
PRE-OPERATION CHECK	13
DAILY CHECK	13
OPERATING THE ENGINE.....	14
EXHAUST AFTERTREATMENT DEVICES.....	14
Dual Exhaust Aftertreatment Devices.....	14
DIESEL PARTICULATE FILTER (DPF) MUFFLER.....	14
Handling Points.....	15
DPF Regeneration Process	15
Operating Procedure for Auto Regeneration Mode	16
Operating Procedure for Regeneration Inhibit Mode	18
Operating Procedure for Parked Regeneration	20
Tips on Diesel Particulate Filter (DPF) Regeneration.....	21
SELECTIVE CATALYTIC REDUCTION (SCR) MUFFLER	21
Outline of the SCR.....	21
DEF/AdBlue®	22
Warning Indication and its Countermeasure.....	22
Storing and Handling DEF/AdBlue®.....	27
STARTING THE ENGINE	27
COLD WEATHER STARTING	30
Block Heater (if equipped)	30
Engine Low Temperature Regulation	31
DEF/AdBlue® Freeze Warning.....	31
STOPPING THE ENGINE.....	32
WARMING UP	32
Warm-up and Transmission Oil at Low Temperature Range	32
JUMP STARTING	33
OPERATING THE TRACTOR.....	34
OPERATING NEW TRACTOR	34
Do not Operate the Tractor at Full Speed for the First 50 Hours.....	34
Changing Lubricating Oil for New Tractors.....	34
BOARDING AND LEAVING THE TRACTOR	34
STARTING	34
Operator's Seat.....	34
Seat Belt	35

Muffler.....	35
Tilt Steering Adjustment.....	35
Light Switch	36
Turn Signal / Hazard Light Switch	36
Rear Turn Signal / Hazard Light	37
Horn Button.....	37
Brake Pedals (Right and Left).....	37
Parking Brake Lever	39
Clutch Pedal	39
Travel Speed Limiter.....	40
Main Gear Shift Lever.....	41
Range Gear Shift Lever.....	41
Shuttle Shift Lever	41
Dual Speed Shift Switch	41
Clutch Off Switch	42
Creep Speed (if equipped).....	42
4WD / Bi-speed Turn Switch.....	43
Hand Throttle Lever.....	44
Foot Throttle	44
STOPPING.....	44
Stopping.....	44
CHECK DURING DRIVING	44
Engine Over-speed Limiting Indicator.....	44
Immediately Stop the Engine if:.....	44
Easy Checker(TM).....	45
Fuel Gauge	46
DEF / AdBlue® Gauge	47
Coolant Temperature Gauge.....	47
Tachometer.....	47
LCD MONITOR.....	48
Various Setting Mode	49
Performance Monitor	52
ELECTRONIC ENGINE CONTROL.....	53
RPM Dual Memory Setting	53
Constant RPM Management Control.....	55
PARKING.....	55
Parking.....	55
OPERATING TECHNIQUES	56
Differential Lock.....	56
Operating the Tractor on a Road	56
Operating on Slopes and Rough Terrain.....	57
Transport the Tractor Safely.....	57
Directions for Use of Power Steering.....	57
Trailer Electrical Outlet	57
PTO	58
PTO OPERATION.....	58
PTO Clutch Control Switch.....	58
PTO Gear Shift Lever	59
PTO Speed Limiter	59
LCD Monitor Message.....	60
PTO Shaft Cover and Shaft Cap	60

3-POINT HITCH & DRAWBAR	61
3-POINT HITCH	62
Selecting the holes of Lower Links	62
Selecting the Top Link Mounting Holes	62
Drawbar	62
Lifting Rod (Left)	63
Lifting Rod (Right)	63
Top Link	64
Stabilizer	64
DRAWBAR	66
Adjusting Drawbar Length	66
HYDRAULIC UNIT	67
3-POINT HITCH CONTROL SYSTEM	67
Position Control	67
Draft Control	67
Mixed Control	68
Float Control	68
3-point Hitch Lowering Speed	68
REMOTE HYDRAULIC CONTROL SYSTEM	69
Remote Control Valve	69
Remote Control Valve Lever	69
Remote Control Valve Coupler Connecting and Disconnecting	70
Adjusting the flow rate	70
Hydraulic Control Unit Use Reference Chart	72
TIRES, WHEELS AND BALLAST	73
TIRES	73
Inflation Pressure	73
Dual Tires	73
WHEEL ADJUSTMENT	73
Safe Replacement of the Wheel	73
Front Wheels (with 4-wheel drive)	74
Rear Wheels	75
BALLAST	76
Front Ballast	76
Rear Ballast	77
CAB OPERATION	78
DOOR AND WINDOW	78
Locking and Unlocking the Door	78
Opening the Door	78
Rear Window	79
Side Window	79
DOME LIGHT	79
Dome Light	79
WORK LIGHT	80
Work Light Switch	80
Front Work Light	80
Rear Work Light	80
WIPER	81
Front Wiper / Washer Switch	81
Rear Wiper / Washer Switch (if equipped)	81

Using the Wipers in Cold Season	81
AIR CONDITIONER	82
Airflow	82
Air Control Vent	82
Control Panel	84
Operation	84
REAR / SIDE DEFOGGER WITH TIMER (if equipped)	86
INSTALLING THE IMPLEMENT CONTROL BOX	87
ELECTRICAL OUTLET	87
Electrical Outlet	87
MAINTENANCE	88
SERVICE INTERVALS	88
Maintenance Items Chart	90
LUBRICANTS, FUEL AND COOLANT	91
PERIODIC SERVICE	93
HOW TO OPEN THE HOOD	93
Hood	93
Side Cover	94
DAILY CHECK	94
Walk Around Inspection	94
Checking and Refueling	94
Checking the DEF/AdBlue® level and adding the fluid	95
Checking Water Separator	96
Checking Engine Oil Level	96
Checking Transmission Fluid Level	97
Checking Coolant Level	97
Cleaning Evacuator Valve	98
Checking Dust Indicator	98
Cleaning Grill, Radiator and Cooler	98
Checking DPF/SCR Muffler	100
Checking Brake Pedal	100
Checking Gauges, Meter and Easy Checker(TM)	100
Checking Head Light, Turn Signal / Hazard Light etc.	100
Checking Seat Belt	100
Checking Movable Parts	100
INITIAL 50 HOURS	101
Changing Engine Oil	101
Replacing Engine Filter	101
EVERY 50 HOURS	101
Checking Engine Start System	101
Checking Wheel Bolt Torque	102
Checking Tie-rod Dust Cover	102
EVERY 100 HOURS	102
Lubricating Grease Fittings	102
Cleaning Air Cleaner Primary Element	103
Adjusting Fan Belt Tension	104
Adjusting Brake Pedal	105
Checking Gear Locked Parking Brake	106
Checking Battery Condition	106
Adjusting Air-Conditioner Belt Tension	108

EVERY 200 HOURS	109
Adjusting Toe-in.....	109
Draining Fuel Tank Water.....	110
Cleaning Inner Air Filter.....	110
Cleaning Fresh Air Filter	110
EVERY 400 HOURS	111
Cleaning Water Separator	111
Cleaning Fuel Solenoid Pump Element.....	112
EVERY 500 HOURS	112
Changing Engine Oil.....	112
Replacing Engine Oil Filter	113
Replacing Fuel Filter.....	114
Replacing Hydraulic Oil Filter	114
Checking Power Steering Line	115
Checking Radiator Hose and Clamp	116
Checking Fuel Line.....	117
Checking Intake Air Line.....	118
Checking Lift Cylinder Hose	119
Checking Air Conditioner Pipe and Hose	119
Checking Brake Hose.....	119
EVERY 600 HOURS	119
Adjusting Front Axle Pivot.....	119
EVERY 1000 HOURS	120
Changing Transmission Fluid	120
Changing Front Axle Gear Case Oil & Front Differential Case Oil	120
Adjusting Engine Valve Clearance	121
EVERY 1000 HOURS or 1 YEAR.....	121
Replacing Air Cleaner Primary Element and Secondary Element.....	121
Checking Exhaust Manifold	121
EVERY 1500 HOURS.....	121
Cleaning Fuel Injector Nozzle Tip.....	121
Checking DEF/AdBlue® Injector Tip	121
Checking DEF/AdBlue® Line	121
Replacing Oil Separator Element	121
Checking PCV (Positive Crankcase Ventilation) Valve	122
Checking and Cleaning EGR Cooler	122
EVERY 2000 HOURS or 2 YEARS.....	122
Flushing Cooling System and Changing Coolant	122
Anti-Freeze	123
EVERY 3000 HOURS.....	124
Checking Turbocharger	124
Checking Supply Pump	124
Checking Intake Air Heater.....	124
Checking and Cleaning EGR System.....	124
Cleaning DPF Muffler	124
Checking DEF/AdBlue® injector.....	124
Replacing DEF/AdBlue® Pump Filter	125
EVERY 1 YEAR	125
Checking Antifrost Heater for Oil Separator	125
Checking CAB Isolation Cushion.....	125
Checking DPF Differential Pressure Sensor Pipe	125
Checking EGR Pipe.....	125

EVERY 2 YEARS.....	125
Cleaning Master Cylinder Filter	125
Replacing Oil Separator Hose	125
Replacing DPF Differential Pressure Sensor Hose	125
Replacing EGR Cooler Hose	125
Replacing Boost Sensor Hose.....	125
EVERY 3 YEARS.....	125
Replacing Parking Brake Cable.....	125
EVERY 4 YEARS.....	126
Replacing Radiator Hose (Water pipes)	126
Replacing Fuel Hose	126
Replacing Intake Air Line.....	126
Replacing Oil Cooler Line	126
Replacing Power Steering Hose.....	126
Replacing Lift Cylinder Hose	126
Replacing Brake Hose.....	126
Replacing Master Cylinder Kit	126
Replacing Equalizer Kit.....	126
Replacing Brake Seal 1 and 2	126
Replacing Air Conditioner Hose.....	126
SERVICE AS REQUIRED.....	126
Bleeding Fuel System.....	126
Bleeding Brake System	127
Draining Clutch Housing Water	127
Replacing Fuse.....	128
Replacing Slow-Blow Fuses	130
Replacing Light Bulb.....	131
Replacing Head Lamp	131
Lubricating Points	132
Adding Washer Liquid.....	132
Checking the Amount of Refrigerant (gas)	132
STORAGE	134
TRACTOR STORAGE	134
REMOVING THE TRACTOR FROM STORAGE.....	134
TROUBLESHOOTING.....	135
ENGINE TROUBLESHOOTING	135
POWER TRAIN TROUBLE SHOOTING.....	137
OPTIONS.....	138
MOUNTING THE SUPPORT PLATE.....	138
Installation Procedures	138
APPENDICES.....	140
INDEX	140



SAFE OPERATION

Careful operation is your best insurance against an accident.

Read and understand this manual carefully before operating the tractor.

All operators, no matter how much experience they may have, should read this and other related manuals before operating the tractor or any implement attached to it. It is the owner's obligation to instruct all operators in safe operation.

1. BEFORE OPERATING THE TRACTOR

1. Know your equipment and its limitations. Read this entire manual before attempting to start and operate the tractor.
2. Pay special attention to the danger, warning and caution labels on the tractor.
3. Do not operate the tractor or any implement attached to it while under the influence of alcohol, medication, controlled substances or while fatigued.
4. Before allowing other people to use your tractor, explain how to operate and have them read this manual before operation.
5. Never wear loose, torn, or bulky clothing around tractor. It may catch on moving parts or controls, leading to the risk of an accident. Use additional safety items, e.g. hard hat, safety boots or shoes, eye and hearing protection, gloves, etc., as appropriate or required.
6. Do not allow passengers to ride on any part of the tractor at anytime. The operator must remain in the tractor seat during operation.
7. Check brakes, clutch, linkage pins and other mechanical parts for improper adjustment and wear. Replace worn or damaged parts promptly. Check the tightness of all nuts and bolts regularly. (For further details, see "MAINTENANCE" section.)
8. Keep your tractor clean. Dirt, grease, and trash build up may contribute to fires and lead to personal injury.
9. Use only implements meeting the specifications listed under "IMPLEMENT LIMITATIONS" in this manual or implements approved by KUBOTA.
10. Use proper weights on the front or rear of the tractor to reduce the risk of upsets. Follow the safe operating procedures specified in the implement or attachment manual.
11. The narrower the tread, the greater the risk of a tractor upset. For maximum stability, adjust the wheels to the widest practical tread width for your application. (See "TIRES, WHEELS AND BALLAST" section.)
12. Do not modify the tractor. Unauthorized modification may affect the function of the tractor, which may result in personal injury.

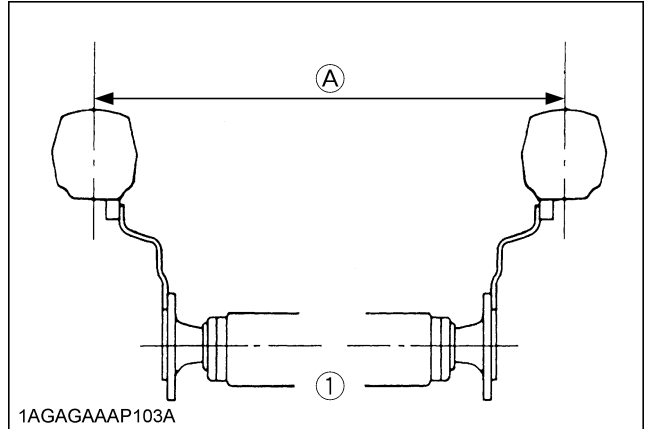

(1) Rear wheels

(A) Tread Width

◆ CAB, ROPS

1. KUBOTA recommends the use of a CAB or Roll Over Protective Structures (ROPS) and seat belt in almost all applications. This combination will reduce the risk of serious injury or death, should the tractor be upset. Check for overhead clearance which may interfere with a CAB or ROPS.
2. If the CAB or ROPS is loosened or removed for any reason, make sure that all parts are reinstalled correctly before operating the tractor.
3. Never modify or repair any structural member of a CAB or ROPS because welding, bending, drilling, grinding, or cutting may weaken the structure.
4. A damaged CAB or ROPS structure must be replaced, not repaired or revised.
5. If any structural member of the CAB or ROPS is damaged, replace the entire structure at your local KUBOTA Dealer.
6. Always use the seat belt if the tractor has a CAB or ROPS. Do not use the seat belt if there is no CAB or ROPS. Check the seat belt regularly and replace if frayed or damaged.

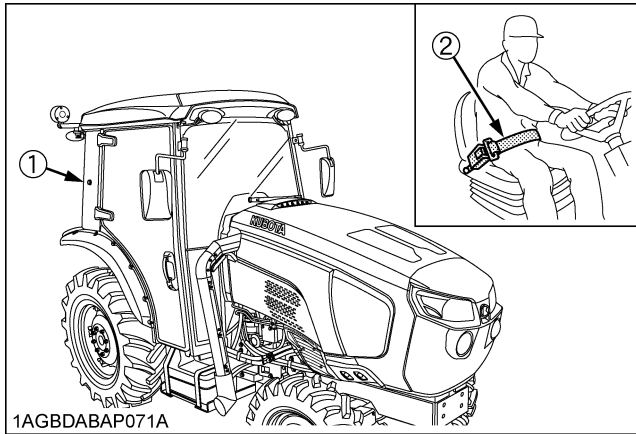

- (1) CAB
(2) Seat belt

7. The CAB is not tested for FOPS (Falling Object Protection Structure).

2. OPERATING THE TRACTOR

Operator safety is a priority. Safe operation, specifically with respect to overturning hazards, entails understanding the equipment and environmental conditions at the time of use. Some prohibited uses which can affect overturning hazards include traveling and turning with implements and loads carried too high etc. This manual sets forth some of the obvious risks, but the list is not, and cannot be, exhaustive. It is the operator's responsibility to be alert for any equipment or environmental condition that could compromise safe operation.

◆ Starting

1. Always sit in the operator's seat when starting engine or operating levers or controls. Adjust seat per instructions in the operating the tractor section. Never start engine while standing on the ground.
2. KUBOTA recommends that you get on and off the tractor from the left side only; however, in the event of an EMERGENCY, you may exit using the right side door. Use caution in using the EMERGENCY right side door, as there are no steps from the CAB to the ground on the right side.
3. Before starting the engine, make sure that all levers (including auxiliary control levers) are in their neutral positions, that the parking brake is engaged, and that both the clutch and the Power Take-Off (PTO) are disengaged or "OFF".
Fasten the seat belt if the tractor has a CAB, a fixed ROPS or a foldable ROPS in the upright and locked position.
4. Do not start engine by shorting across starter terminals or bypassing the safety start switch. Machine may start in gear and move if normal starting circuitry is bypassed.

5. Do not operate or idle engine in a non-ventilated area. Carbon monoxide gas is colorless, odorless, and deadly.
6. Check before each use that operator presence controls are functioning correctly. Test safety systems. (See "Checking Engine Start System" in "EVERY 50 HOURS" in "PERIODIC SERVICE" section.)
Do not operate unless they are functioning correctly.

◆ Working

1. Pull only from the drawbar. Never hitch to axle housing or any other point except drawbar; such arrangements will increase the risk of serious personal injury or death due to a tractor upset.

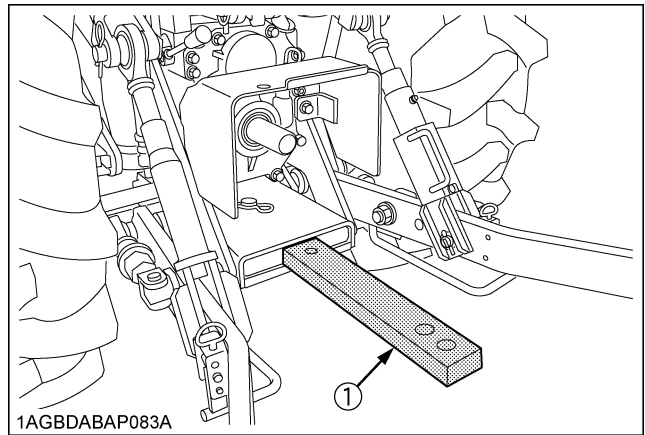

- (1) Drawbar

2. For trailing PTO-driven implements, set the drawbar to the towing position.
3. Attach pulled or towed loads to the drawbar only.
4. Keep all shields and guards in place. Replace any that are missing or damaged.
5. Avoid sudden starts. To avoid upsets, slow down when turning, on uneven ground, and before stopping.
6. The tractor cannot turn with the differential locked and attempting to do so could be dangerous.
7. Do not operate near ditches, holes, embankments, or other ground surface features which may collapse under the tractor's weight. The risk of tractor upset is even higher when the ground is loose or wet. Tall grass can hide obstacles, walk the area first to be sure.
8. Watch where you are going at all times. Watch for and avoid obstacles. Be alert at row ends, near trees, and other obstructions.
9. When working in groups, always let the others know what you are going to do before you do it.
10. Never try to get on or off a moving tractor.
11. Always sit in the operator's seat when operating levers or controls.
12. Do not use "Bi-speed Turn" at high speed.
13. "Bi-Speed Turn" enables short and fast turns, therefore, become familiar with its performance before operating in close or confined areas.

14. Do not stand between tractor and implement or trailed vehicle unless parking brake is applied.

◆ Safety for children

Tragedy can occur if the operator is not alert to the presence of children. Children generally are attracted to machines and the work they do.

1. Never assume that children will remain where you last saw them.
2. Keep children out of the work area and under the watchful eye of another responsible adult.
3. Be alert and shut your machine down if children enter the work area.
4. Never carry children on your machine. There is no safe place for them to ride. They may fall off and be run over or interfere with your control of the machine.
5. Never allow children to operate the machine even under adult supervision.
6. Never allow children to play on the machine or on the implement.
7. Use extra caution when backing up. Look behind and down to make sure area is clear before moving.

◆ Operating on slopes

Slopes are a major factor related to loss-of-control and tip-over accidents, which can result in severe injury or death. All slopes require extra caution.

1. To avoid upsets, always back up steep slopes. If you cannot back up the slope or if you feel uneasy on it, do not operate on it. Stay off slopes too steep for safe operation.
2. Driving forward out of a ditch, mired condition or up a steep slope increases the risk of a tractor to be upset backward. Always back out of these situations. Extra caution is required with 4-wheel drive models because their increased traction can give the operator false confidence in the tractor's ability to climb slopes.
3. Keep all movement on slopes slow and gradual. Do not make sudden changes in speed, direction or apply brake and make sudden motions of the steering wheel.
4. Avoid disengaging the clutch or changing gears speed when climbing or going down a slope. If on a slope disengaging the clutch or changing gears to neutral could cause loss of control.
5. Special attention should be made to the weight and location of implements and loads as such will affect the stability of the tractor.
6. To improve stability on slope, set widest wheel tread as shown in "TIRES, WHEELS AND BALLAST" section.
Follow recommendations for proper ballasting.
7. To avoid free wheeling:
 - Do not shift the shuttle lever while on a slope.
 - Stop completely by using the brake and by depressing the clutch pedal, then shift the shuttle lever.
 - Start off after selecting shuttle direction, by releasing the clutch pedal.

8. When driving down a slope, ensure that 4-wheel drive is engaged to increase traction (if equipped).

◆ Driving the tractor on the road

1. Lock the 2 brake pedals together to help assure straight-line stops. Uneven braking at road speeds could cause the tractor to tip over.

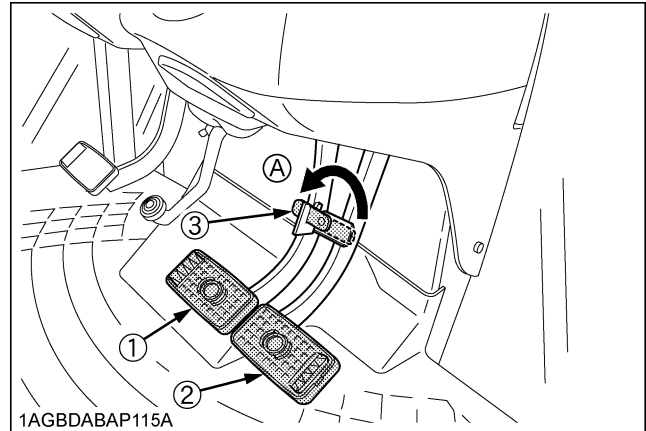

- (1) Brake Pedal (LH) (A) Whenever travelling on the road
(2) Brake Pedal (RH)
(3) Brake Pedal Lock

2. Check the front wheel engagement. The braking characteristics are different between 2 and 4-wheel drive. Be aware of the difference and use carefully.
3. Always slow the tractor down before turning. Turning at high speed may tip the tractor over.
4. Make sure that the Slow Moving Vehicle (SMV) sign is clean and visible. Use hazard lights and turn signals as required.

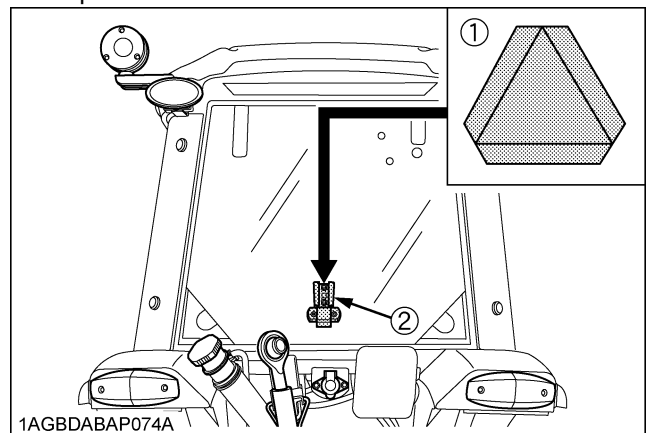

- (1) SMV emblem
(2) Bracket

5. On public roads use the SMV emblem and hazard lights, if required by local traffic and safety regulations.
6. Observe all local traffic and safety regulations.
7. Turn the headlights on. Dim them when meeting another vehicle.
8. Drive at speeds that allow you to maintain control at all times.

▲-4 SAFE OPERATION

9. Do not apply the differential lock while traveling at road speeds. The tractor may run out of control.
10. Avoid sudden motions of the steering wheel as they can lead to a dangerous loss of stability. The risk is especially great when the tractor is traveling at road speeds.
11. Do not operate an implement while the tractor is on the road. Lock the 3-point hitch in the raised position.
12. When towing other equipment, use a safety chain and place an SMV emblem on it as well.

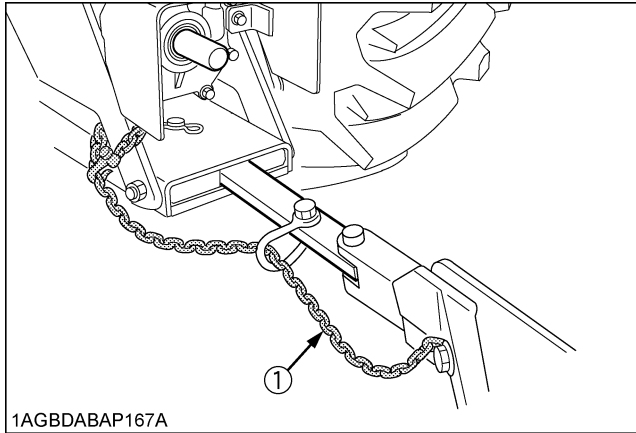

1AGBDABAP167A

(1) Safety chain

13. Set the implement lowering speed knob in the "LOCK" position to hold the implement in the raised position.

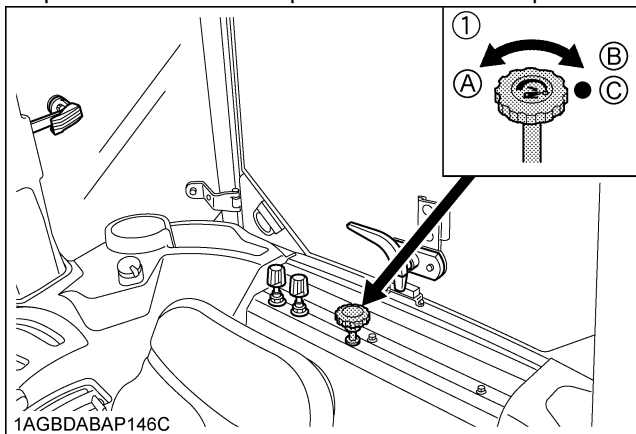

1AGBDABAP146C

(1) 3-point hitch lowering speed knob

(A) "FAST"
(B) "SLOW"
(C) "LOCK"

3. PARKING THE TRACTOR

1. Disengage the PTO, lower all implements to the ground, place all control levers in their neutral positions, set the parking brake, stop the engine, remove the key from the ignition and lock the cab door (if equipped). Leaving transmission in gear with the engine stopped will not prevent tractor from rolling.
2. Make sure that the tractor has come to a complete stop before dismounting.

3. Avoid parking on steep slopes, if at all possible park on a firm and level surface; if not, park across a slope and chock the wheels.

Failure to comply with this warning may allow the tractor to move and could cause injury or death.

4. OPERATING THE PTO

1. Wait until all moving components have completely stopped before getting off the tractor, connecting, disconnecting, adjusting, cleaning, or servicing any PTO driven equipment.
2. Keep the PTO shaft cover in place at all times. Replace the PTO shaft cap when the shaft is not in use.

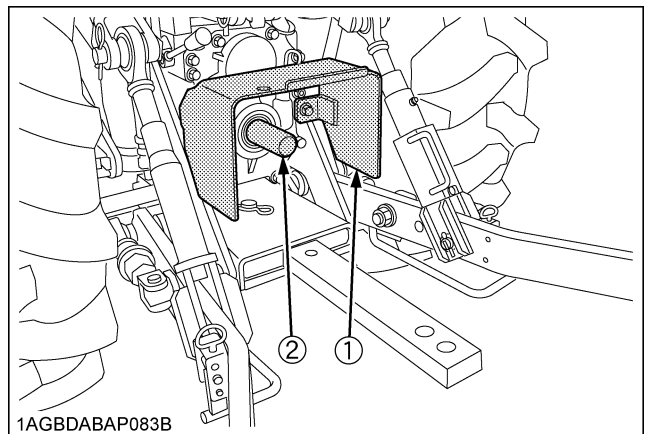

1AGBDABAP083B

(1) PTO Shaft cover
(2) PTO Shaft cap

3. Before installing or using PTO driven equipment, read the manufacturer's manual and review the safety labels attached to the equipment. To prevent PTO driven equipment from improper or unsafe use, select the lower speed (540rpm) unless the higher one is specifically recommended as safe by the equipment manufacturer.
4. When operating stationary PTO driven equipment, always apply the tractor parking brake and place chocks behind and in front of the rear wheels. Stay clear of all rotating parts. Never step over rotating parts.

5. USING 3-POINT HITCH

1. Use the 3-point hitch only with equipment designed for 3-point hitch usage.
2. When using a 3-point hitch mounted implement, be sure to install the proper counterbalance weight on the front of the tractor.
3. To avoid injury from separation:
Do not extend lift rod beyond the groove on the threaded rod.

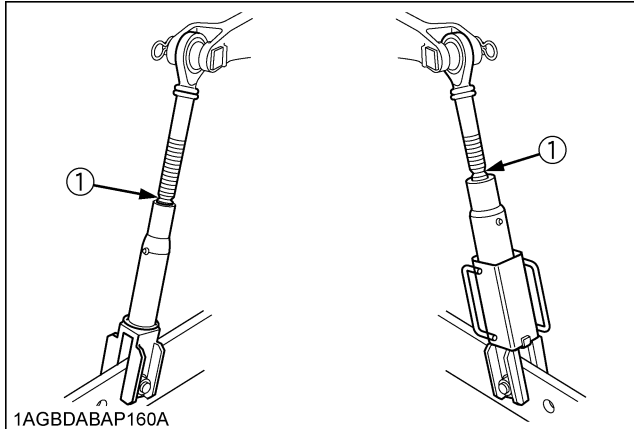

(1) Groove

6. SERVICING THE TRACTOR

Before servicing the tractor, park it on a firm, flat and level surface, set the parking brake, lower all implements to the ground, place the gear shift lever in neutral, stop the engine and remove the key.

1. Allow the tractor time to cool off before working on or near the engine, muffler, radiator, etc.
2. Do not remove radiator cap while coolant is hot. When cool, slowly rotate cap to the first stop and allow sufficient time for excess pressure to escape before removing the cap completely. If the tractor has a coolant recovery tank, add coolant or water to the tank, not the radiator. (See "Checking Coolant Level" in "DAILY CHECK" in "PERIODIC SERVICE" section.)
3. Always stop the engine before refueling. Avoid spills and overfilling.
4. Do not smoke when working around battery or when refueling. Keep all sparks and flames away from battery and fuel tank. The battery presents an explosive hazard, because it gives off hydrogen and oxygen especially when recharging.
5. Before "jump starting" a dead battery, read and follow all of the instructions. (See "JUMP STARTING" in "OPERATING THE ENGINE" section.)
6. Keep first aid kit and fire extinguisher handy at all times.

7. Disconnect the battery's ground cable before working on or near electric components.
8. To avoid the possibility of battery explosion, do not use or charge the refillable type battery if the fluid level is below the LOWER (lower limit level) mark. Check the fluid level regularly and add distilled water as required so that the fluid level is between the UPPER and LOWER levels.
9. To avoid sparks from an accidental short circuit, always disconnect the battery's ground cable (-) first and reconnect it last.

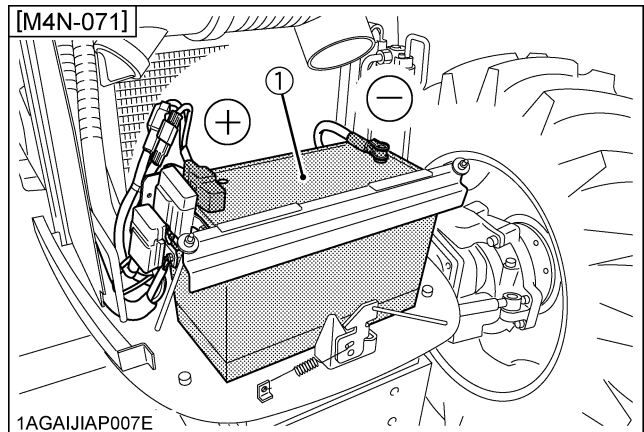

(1) Battery

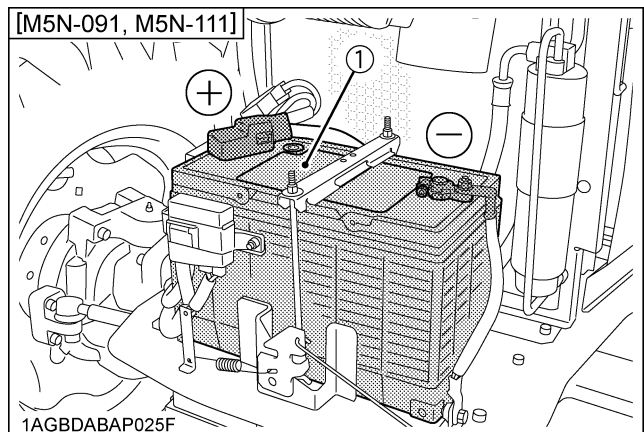

(1) Battery

10. Do not attempt to mount a tire on a rim. This should be done by a qualified person with the proper equipment.

11. Always maintain the correct tire pressure. Do not inflate tires above the recommended pressure shown in the operator's manual.

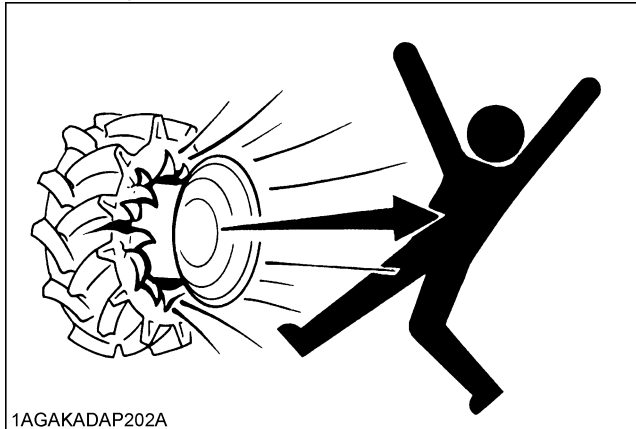

- 12. Securely support the tractor when either changing wheels or adjusting the wheel tread width.
- 13. Make sure that wheel bolts have been tightened to the specified torque.
- 14. Disconnect the battery's ground cable and stop the engine to avoid the possibility of the machine runaway due to 4WD braking system during testing, service or repair with only rear wheels off the ground.
- 15. Do not work under any hydraulically supported devices. They can settle, suddenly leak down, or be accidentally lowered. If it is necessary to work under tractor or any machine elements for servicing or adjustment, securely support them with stands or suitable blocking beforehand.
- 16. Escaping hydraulic fluid under pressure has sufficient force to penetrate skin, causing serious personal injury. Before disconnecting hydraulic lines, be sure to release all residual pressure. Before applying pressure to the hydraulic system, make sure that all connections are tight and that all lines, pipes, and hoses are free of damage.

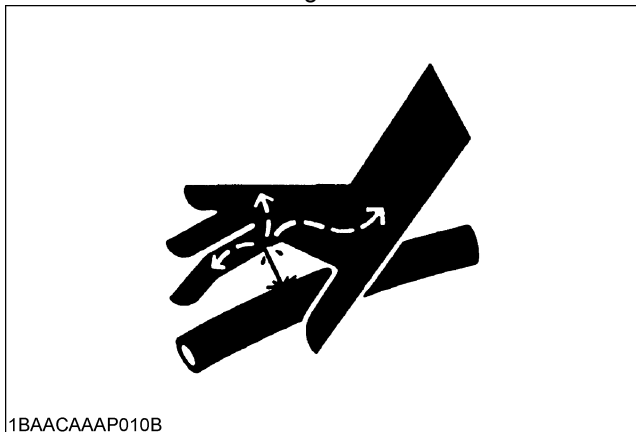

17. Fluid escaping from pinholes may be invisible. Do not use hands to search for suspected leaks; use a piece of cardboard or wood. Use of safety goggles or other eye protection is also highly recommended. If injured by escaping fluid, see a medical doctor at once. This fluid will produce gangrene or severe allergic reaction.

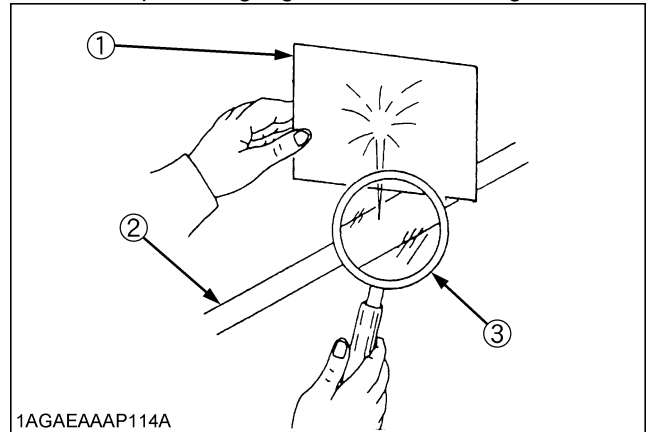

- (1) Cardboard
- (2) Hydraulic line
- (3) Magnifying glass

- 18. Do not open high-pressure fuel system. High-pressure fluid remaining in fuel lines can cause serious injury. Do not disconnect nor attempt to repair fuel lines, sensors, or any other components between the high-pressure fuel pump and injectors on engines with high pressure common rail fuel system.
- 19. To avoid hazardous high voltage, turn the key switch to the OFF position if it is necessary to check to repair the computer, harness or connectors.
- 20. During Diesel Particulate Filter (hereinafter called DPF) regenerating operations, exhaust gases and exhaust filter components reach temperatures hot enough to burn people, or ignite or melt common materials.
- 21. Keep the tractor away from people, animals or structures which may be susceptible to harm or damage from hot exhaust gases.
- 22. To prevent fires, keep the DPF muffler and its surroundings clear of anything flammable and keep clean at all times.
- 23. To prevent fires, keep the DPF/SCR muffler and its surroundings clear of anything flammable and keep clean at all times. [Selective Catalytic Reduction (hereinafter called SCR)]
- 24. During regeneration, white exhaust gas may be visible. Do not allow regeneration in a non-ventilated space.
- 25. During regeneration, do not leave the tractor.

7. DANGER, WARNING AND CAUTION LABELS

(1) Part No. K3512-4719-1

Do not touch hot surface like supply pump, etc.



1BDABANAP080A

(2) Part No. 6C090-4958-2

Do not get your hands close to engine fan and fan belt.

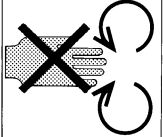

1AGAIAZAP110A

(3) Part No. 3Y205-9892-1

⚠ DANGER/POISON

<p>SHIELD EYES. EXPLOSIVE GASES CAN CAUSE BLINDNESS OR INJURY.</p>	<p>NO SPARKS OR FLAMES. Sulfuric acid can cause blindness or severe burns.</p>	<p>SULFURIC ACID CAN CAUSE BLINDNESS OR SEVERE BURNS.</p>
--	--	---

KEEP OUT OF REACH OF CHILDREN. DO NOT TIP. DO NOT OPEN BATTERY.

FLUSH EYES IMMEDIATELY WITH WATER. GET MEDICAL HELP FAST.

PROPOSITION 65 WARNING
 BATTERY POSTS, TERMINALS, AND RELATED ACCESSORIES CONTAIN LEAD AND LEAD COMPOUNDS, CHEMICALS KNOWN TO THE STATE OF CALIFORNIA TO CAUSE CANCER AND REPRODUCTIVE HARM. WASH HANDS AFTER HANDLING.

OK 95330

105E41R 12V

AMP. HR (5HR)	80
AMP. HR (20HR)	100
RESERVE CAPACITY (MIN)	160
BCI CCA	900
EN CCA	800

S.O.C INDICATOR

OK	CHARGE BATTERY	REPLACE BATTERY
----	----------------	-----------------

Pb

1AGAIJHAP083A

(4) Part No. 3A851-7295-1

⚠ CAUTION REFRIGERANT UNDER HIGH PRESSURE **⚠ ATTENTION REFRIGERANT SOUS HAUTE PRESSION**

Improper service methods may cause injury. Air conditioning system should be serviced by qualified personnel. See Repair Manual.

Un entretien incorrect peut provoquer des blessures. Le système de climatisation doit être entretenu par une personne qualifiée. Voir le manuel de réparation.

<p>Refrigerant HFC134a Max. 0.95kg (2.09lbs.) USE ONLY Min. 0.85kg (1.87lbs.)</p>	<p>Oil ND-OIL 8 SAE OR EQUIVALENT J-639</p>	<p>Refrigerant HFC134a Max. 0.95kg (2.09lbs.) UNIQUEMENT Min. 0.85kg (1.87lbs.)</p>	<p>Huile ND-OIL 8 SAE OU EQUIVALENTE J-639</p>
---	---	---	--

MFD. BY DENSO CORPORATION JAPAN. FABRIQUE PAR DENSO CORPORATION JAPON.

1AGAIDGAP074A

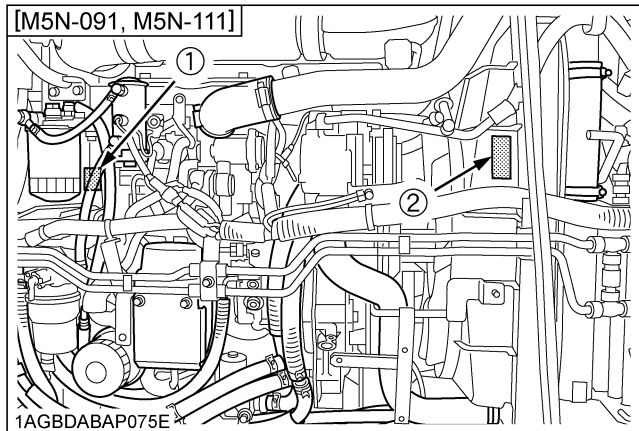

1AGBDABAP075E

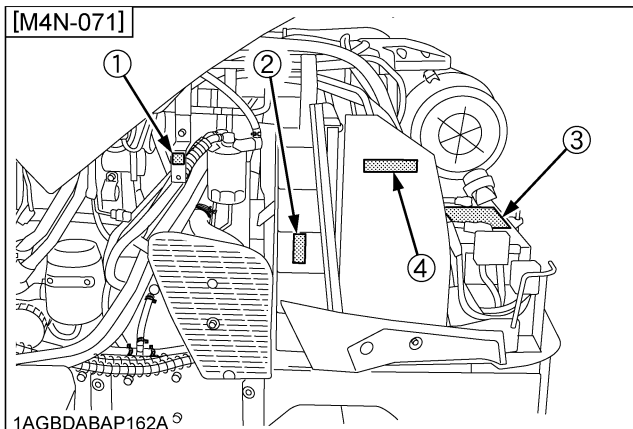

1AGBDABAP162A

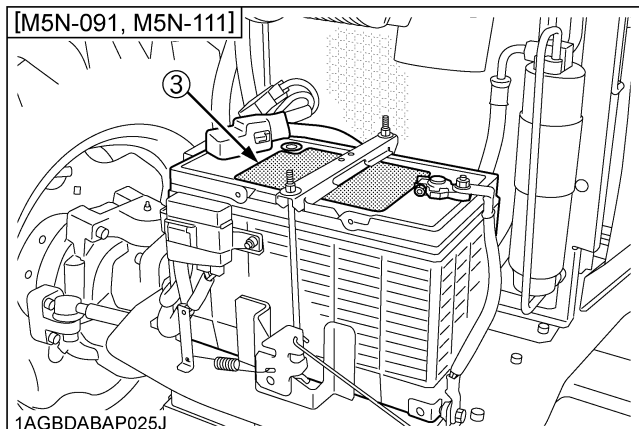

1AGBDABAP025J

1AGBDABAP107A

(1) Part No. 6C090-4958-2
Do not get your hands close to engine fan and fan belt.



1AGAI AZAP110A

(2) Part No. TC660-9861-1

▲ WARNING

TO AVOID PERSONAL INJURY OR DEATH:
When the Diesel Particulate Filter (DPF) is in the regenerating mode, the exhaust gas and the DPF muffler become hot. During regeneration, take into account that the muffler will be very hot and keep the machine away from other people, animals, plants, and flammable material. Also keep the area near the DPF muffler clean and away from flammable material.

1AGAHAKAP051A

(3) Part No. TA040-4958-1
Do not touch hot surface like muffler, etc.



1AGAMAAAP2400

(4) Part No. K3512-4719-1
Do not touch hot surface like supply pump, etc.



1BDABANAP080A

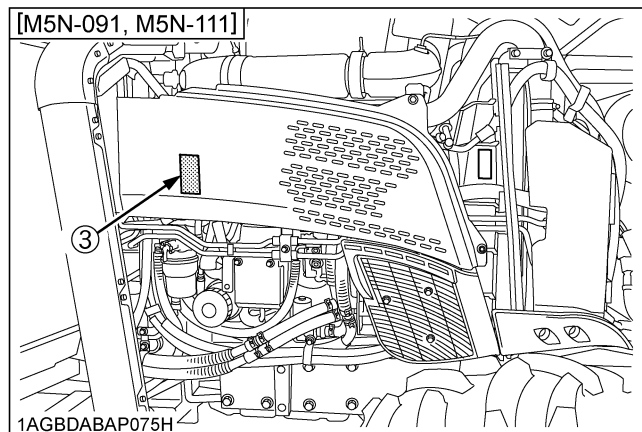
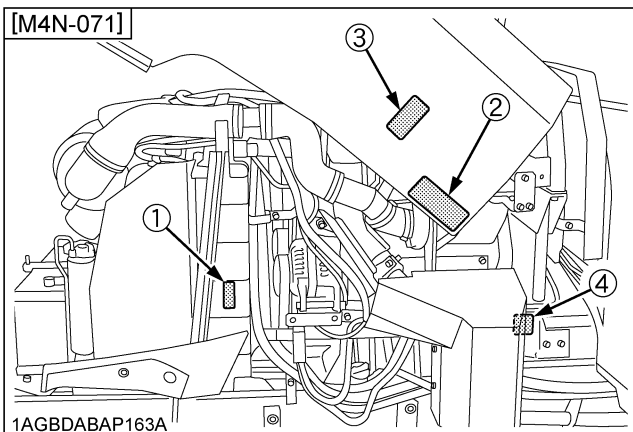
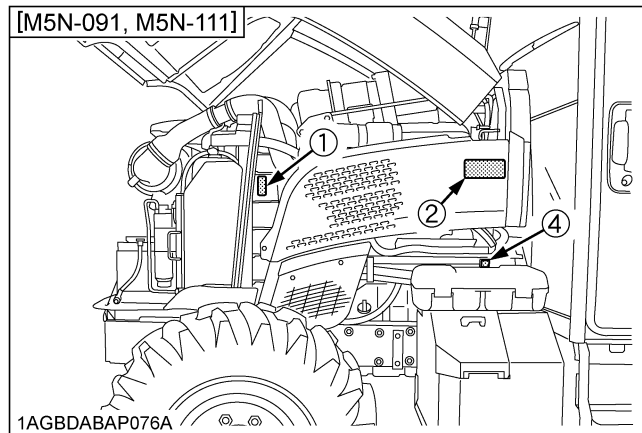

1AGBDABAP108A

(1) Part No. 3C581-9858-1

	<p style="text-align: center;">⚠ DANGER</p> <p>TO AVOID POSSIBLE INJURY OR DEATH FROM A MACHINE RUNAWAY.</p> <ol style="list-style-type: none"> 1. Do not start engine by shorting across starter terminals or bypassing the safety start switch. Machine may start in gear and move if normal starting circuitry is bypassed. 2. Start engine only from operator's seat with transmission and PTO OFF. Never start engine while standing on the ground.
---	--

1AGAIAZAP009A

(2) Part No. 3F240-9857-1

<p style="text-align: center;">⚠ WARNING</p> <p>To avoid free wheeling when shifting the shuttle lever while on a slope : Stop completely by using the brake and by depressing the clutch pedal. Start off after selecting shuttle direction by releasing the clutch pedal.</p>

1AGAIBDAP039A

(3) Part No. 6C150-4743-1

<p style="text-align: center;">⚠ WARNING</p>	<p>BEFORE DISMOUNTING TRACTOR:</p> <ol style="list-style-type: none"> 1. ALWAYS SET PARKING BRAKE. Leaving transmission in gear with the engine stopped will not prevent tractor from rolling. 2. PARK ON LEVEL GROUND WHENEVER POSSIBLE. If parking on a slope, position tractor across the slope. 3. LOWER ALL IMPLEMENTS TO THE GROUND. 4. STOP THE ENGINE.
	

1AGAIBDAP040A

(4) Part No. 3F240-9821-1

<p style="text-align: center;">⚠ WARNING</p> <p>TO AVOID MACHINE RUNAWAY DUE TO 4WD BRAKING SYSTEM:</p> <p>Do not run engine with only rear wheels off ground.</p>
--

1AGAIPIAP1820

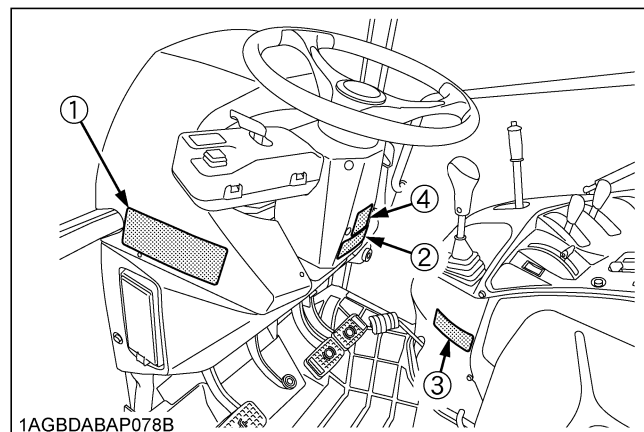

1AGBDABAP078B

1AGBDABAP109A

(1) Part No. 3S205-9836-1

▲ WARNING
TO AVOID PERSONAL INJURY OR DEATH:

1. Read and understand the operator's manual before operation.
2. Before starting the engine, make sure that everyone is at a safe distance from tractor and the PTO is off.
3. Do not allow passengers on the tractor at any time.
4. Before allowing other people to use the tractor, have them read the operator's manual.
5. Check the tightness of nuts and bolts regularly.
6. Keep all shields in place and stay away from all moving parts.
7. Lock the two brake pedals together before driving on the road.
8. Slow down for turns, or rough roads, or when applying individual brakes.
9. On public roads use SMV emblem and hazard lights, if required by local traffic and safety regulations.
10. Pull only from the drawbar.
11. Before dismounting, lower the implement to the ground, set the parking brake, stop the engine and remove the key.
12. Securely support tractor and implements before working underneath.

1AGBEAAP061A

(2) Part No. TA040-4902-1

▲ WARNING



TO AVOID INJURY OR DEATH FROM ROLL-OVER:
 Always use seat belt when driving.

1AGAMAOP078A

(3) Part No. 3F240-4905-2



▲ WARNING
 To avoid personal injury :
 Use "Bi-speed Turn" only in low gears and slow speed. Do not use "Bi-speed Turn" in high gears or road speed.

1AGAIBIAP1780

(4) Part No. 3B794-9839-1

Emergency exit



1AGBDABAP216A

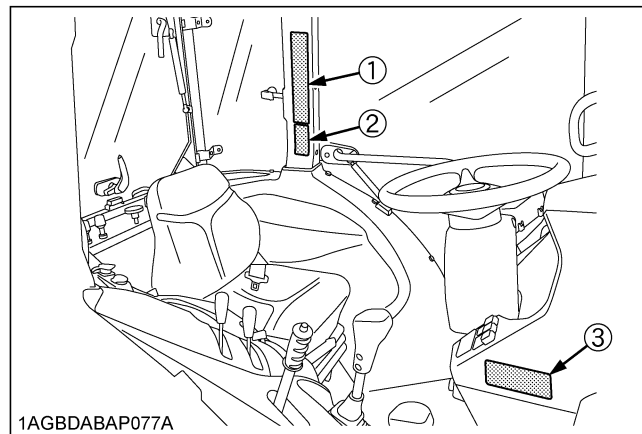

1AGBDABAP077A

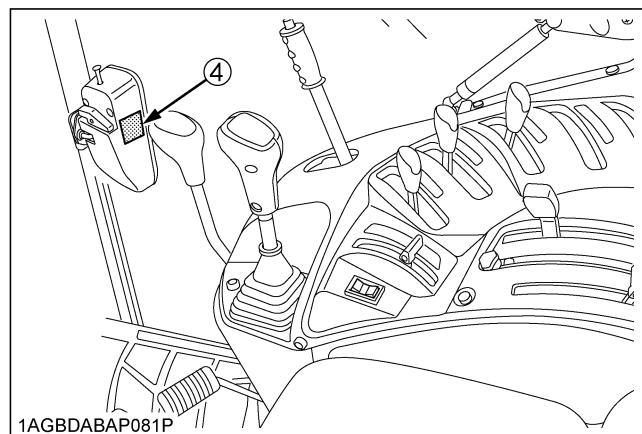

1AGBDABAP081P

1AGBDABAP110A

(1) Part No. TA040-4935-1

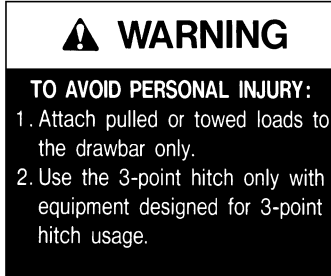

1AGAIAZAP056A

(2) Part No. 3B291-9856-1



1AGBDAAAP053A

(3) Part No. TA040-4959-3

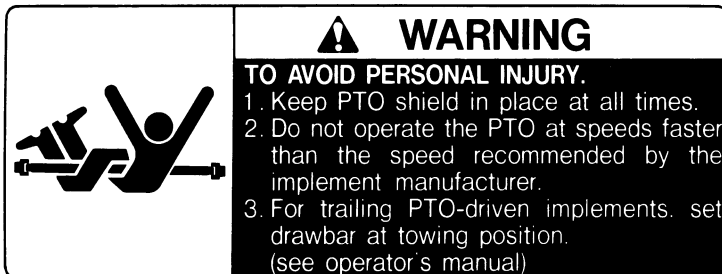

1AGAIAZAP116A

(4) Part No. TC420-4956-1

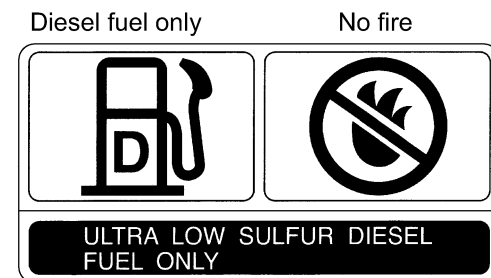

1AGAIDHAP154E

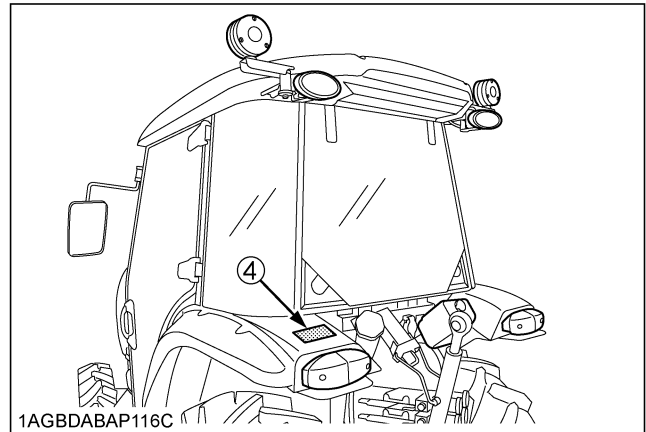
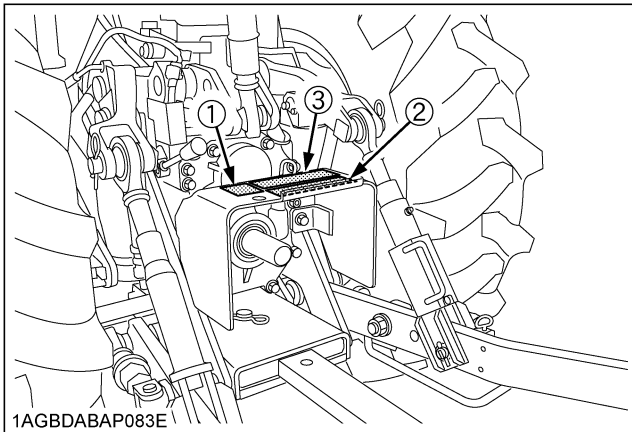

1AGBDABAP111A

8. CARE OF DANGER, WARNING AND CAUTION LABELS

1. Keep danger, warning and caution labels clean and free from obstructing material.
2. Clean danger, warning and caution labels with soap and water, dry with a soft cloth.
3. Replace damaged or missing danger, warning and caution labels with new labels from your local KUBOTA Dealer.
4. If a component with danger, warning and caution label(s) affixed is replaced with new part, make sure new label(s) is (are) attached in the same location(s) as the replaced component.
5. Mount new danger, warning and caution labels by applying on a clean dry surface and pressing any bubbles to outside edge.

SERVICING OF TRACTOR

Your dealer is interested in your new tractor and has the desire to help you get the most value from it. After reading this manual thoroughly, you will find that you can do some of the regular maintenance yourself.

However, when in need of parts or major service, be sure to see your KUBOTA Dealer.

For service, contact the KUBOTA Dealership from which you purchased your tractor or your local KUBOTA Dealer.

When in need of parts, be prepared to give your dealer the tractor, CAB/ROPS and engine serial numbers.

Locate the serial numbers now and record them in the space provided.

	Type	Serial No.
Tractor		
CAB / ROPS		
Engine		
Date of Purchase		
Name of Dealer		
(To be filled in by purchaser)		

◆ **Warranty**

This tractor is warranted under the KUBOTA Limited Express Warranty, a copy of which may be obtained from your selling dealer. No warranty shall, however, apply if the tractor has not been handled according to the instruction given in the Operator's Manual even it is within the warranty period.

◆ **Scrapping the tractor and its procedure**

To put the tractor out of service, correctly follow the local rules and regulations of the country or territory where you scrap it. If you have questions, consult your local KUBOTA Dealer.

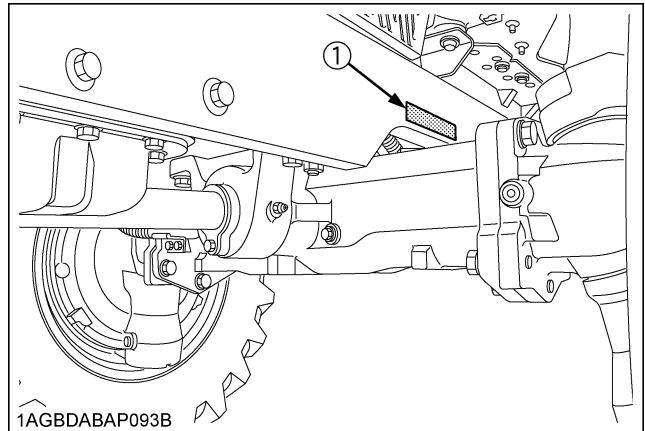

(1) Tractor identification plate

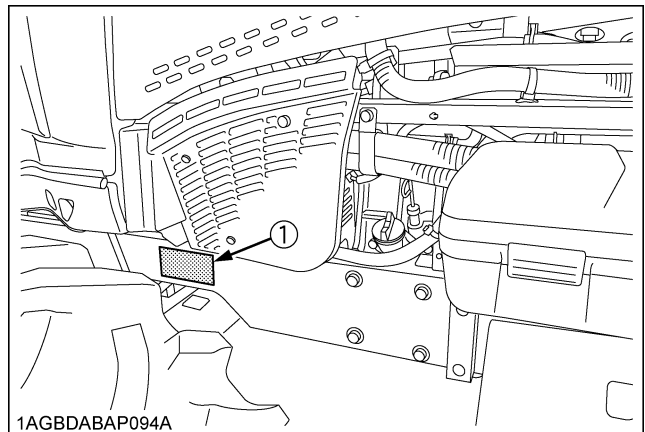

(1) Tractor serial number

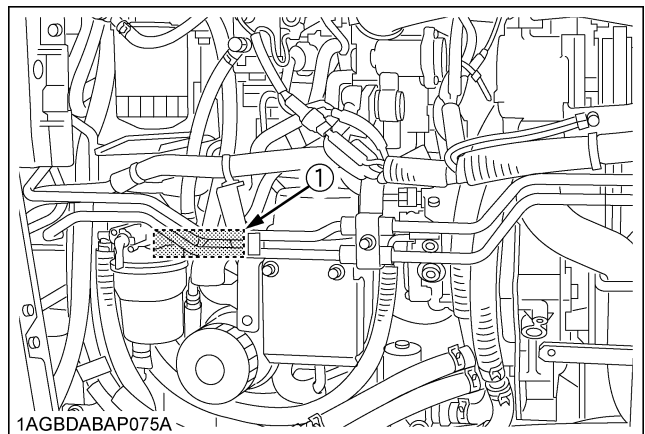

(1) Engine serial number

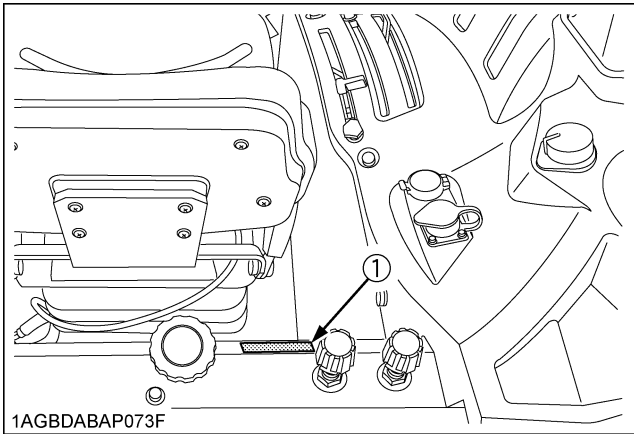

(1) CAB identification plate (CAB Serial No.)

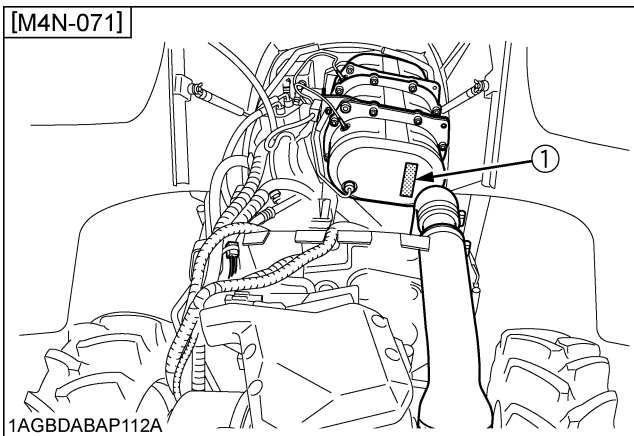

(1) Diesel Particulate Filter (DPF) serial number

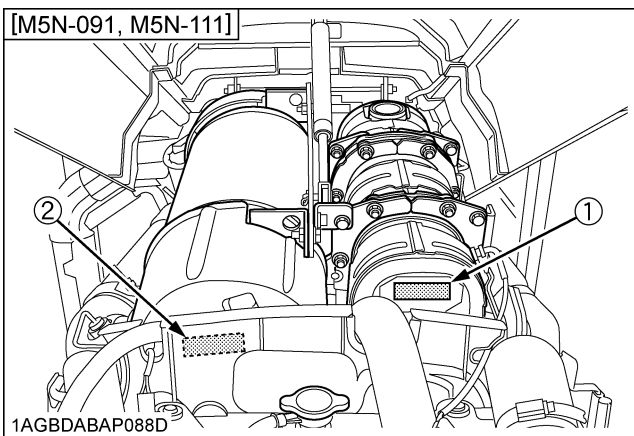

*(1) Diesel Particulate Filter (DPF) serial number
(2) Selective Catalytic Reduction (SCR) muffler serial number*

SPECIFICATIONS

SPECIFICATION TABLE

Model			M4N-071	M5N-091	M5N-111	
			4WD			
Engine	Model		V3800-TE4	V3800-TIEF4		
	Type		Direct Injection, Water-cooled 4 Cycle Diesel, Common Rail System, Turbocharger	Direct Injection, Water-cooled 4 Cycle Diesel, Common Rail System, Turbocharger, Intercooler		
	Number of cylinders		4			
	Total displacement	cm ³ (cu.in.)	3769 (230)			
	Bore and stroke	mm (in.)	100 x 120 (3.9 x 4.7)			
	Rated revolution	rpm	2400	2600		
	Low idling revolution	rpm	800 to 850			
	Rated Engine HP (97/68/EC)	kW (HP)	54.1 (72.6)	70.8 (95.0)	80.7 (108.2)	
	Net power *1	kW (HP)	52.5 (70.4)	65.2 (87.5)	75.1 (100.7)	
	PTO power *1 (factory observed)	kW (HP)	45.5 (61)	[without DS] 58.1 (78) [with DS] 55.9 (75)	[without DS] 67.9 (91) [with DS] 65.6 (88)	
	Maximum torque	N-m (ft-lbs) / rpm	270 (199) / 1500	307 (226) / 1500	345 (254) / 1500	
	Battery capacity		12V, RC: 160min, CCA 900A			
	Fuel tank capacity	L (U.S.gals.)	76 (20.1)			
	Engine oil capacity	L (U.S.qts.)	10.7 (11.3)			
	Coolant capacity	L (U.S.qts.)	10.0 (11)			
	DEF/AdBlue® capacity	L (U.S.gals.)	---	12.3 (3.2)		
Dimensions	Overall length		3790 (149.2)	3950 (155.5)		
	Overall width (minimum tread)		1220 (48)			
	Overall height		2290 (90.2)			
	Wheel base		2130 (83.9)			
	Tread	Front	1050 (41.3)			
		Rear	970 to 1385 (38.2 to 54.5)			
Minimum ground clearance		310 (12.2) (Drawbar bracket)				
Weight		kg (lbs.)	2400 (5291)	2550 (5622)		

4 SPECIFICATIONS

Model			M4N-071	M5N-091	M5N-111
			4WD		
Traveling system	Standard tire size	Front tires	8-16		
		Rear tires *2	12.4-24		
	Clutch		Multiple wet disc, Electronic Hydraulically operated		
	Steering		Hydraulic Power Steering		
	Braking system		Hydraulically operated wet disc		
	Differential		Bevel gears with differential lock (Rear)		
Hydraulic unit	Hydraulic control system		Position, draft (top link sensing) & mix control		
	Pump capacity	L (U.S.gals.) / min	63.3 (16.7)	68.6 (18.1)	
	3-point hitch		Category 2		
	Max. lifting force	At lifting points *3	kg (lbs.)	2300 (5071)	
		24 in. behind lifting point *3	kg (lbs.)	1500 (3307)	
	Remote hydraulic control		2 standard valves		
	System pressure	MPa (kgf/cm ²)	19.1 (195)		
	Traction system		Swinging drawbar, adjustable in direction		
PTO	Live PTO (Independent)	Direction of turning		Clockwise, viewed from tractor rear	
		PTO/ Engine speed	rpm	6 spline: 540 / 2385 6 spline: 540E / 1764	









The company reserves the right to change the specifications without notice.

- NOTE:** *1 Manufacturer's estimate
 *2 Cast iron disks available for wheels.
 *3 At lower link end with links horizontal.

TRAVELING SPEEDS

◆ M4N-071







(At rated engine rpm)

Model			M4N-071	
			F12 / R12 model	
Tire size (Rear)			12.4-24	
Shuttle shift lever	Range gear shift lever	Main gear shift lever	km/h	mph
Forward 	CREEP (option) 	1	0.28	0.17
		2	0.38	0.24
		3	0.46	0.29
		4	0.63	0.39
		5	0.78	0.49
		6	1.11	0.70
		1	1.9	1.2
		2	2.6	1.6
		3	3.1	2.0
		4	4.3	2.7
		5	5.3	3.3
		6	7.6	4.7
		1	9.6	6.0
		2	13.1	8.2
		3	16.0	10.0
		4	21.9	13.7
		5	27.0	16.9
		6	35.5	22.2
Reverse 	CREEP (option) 	1	0.27	0.17
		2	0.38	0.23
		3	0.46	0.29
		4	0.63	0.39
		5	0.77	0.48
		6	1.11	0.69
		1	1.9	1.2
		2	2.6	1.6
		3	3.1	1.9
		4	4.3	2.7
		5	5.3	3.3
		6	7.5	4.7
		1	9.6	6.0
		2	13.1	8.2
		3	15.9	9.9
		4	21.8	13.6
		5	26.9	16.8
		6	35.2	22.0

The company reserves the right to change the specifications without notice

◆ M5N-091, M5N-111

(At rated engine rpm)

Model			M5N-091, M5N-111					
			F12 / R12 model		Dual speed model			
Tire size (Rear)			12.4-24					
Shuttle shift lever	Range gear shift lever	Main gear shift lever	---		Dual speed:H		Dual speed:L	
			km/h	mph	km/h	mph	km/h	mph
Forward 	CREEP (option)	1	0.30	0.19	0.30	0.19	0.25	0.16
		2	0.41	0.26	0.41	0.25	0.34	0.21
		3	0.50	0.31	0.49	0.31	0.41	0.26
		4	0.68	0.43	0.67	0.42	0.57	0.35
		5	0.84	0.53	0.83	0.52	0.70	0.44
		6	1.20	0.75	1.19	0.75	1.00	0.63
		1	2.0	1.3	2.0	1.3	1.7	1.1
		2	2.8	1.7	2.8	1.7	2.3	1.5
		3	3.4	2.1	3.4	2.1	2.8	1.8
		4	4.6	2.9	4.6	2.9	3.9	2.4
		5	5.7	3.6	5.7	3.5	4.8	3.0
		6	8.2	5.1	8.1	5.1	6.8	4.3
		1	10.4	6.5	10.3	6.4	8.7	5.4
		2	14.2	8.9	14.1	8.8	11.9	7.4
		3	17.3	10.8	17.1	10.7	14.4	9.0
		4	23.7	14.8	23.5	14.7	19.8	12.3
		5	29.3	18.3	29.0	18.1	24.4	15.2
		6	35.5	22.2	35.1	21.9	29.5	18.5
Reverse 	CREEP (option)	1	0.30	0.19	0.30	0.19	0.25	0.16
		2	0.41	0.25	0.41	0.26	0.35	0.22
		3	0.49	0.31	0.50	0.31	0.42	0.26
		4	0.68	0.42	0.68	0.43	0.58	0.36
		5	0.84	0.52	0.84	0.53	0.71	0.44
		6	1.20	0.75	1.21	0.75	1.02	0.64
		1	2.0	1.3	2.0	1.3	1.7	1.1
		2	2.8	1.7	2.8	1.7	2.3	1.5
		3	3.4	2.1	3.4	2.1	2.9	1.8
		4	4.6	2.9	4.6	2.9	3.9	2.4
		5	5.7	3.6	5.7	3.6	4.8	3.0
		6	8.1	5.1	8.2	5.1	6.9	4.3
		1	10.4	6.5	10.4	6.5	8.8	5.5
		2	14.2	8.8	14.3	8.9	12.0	7.5
		3	17.2	10.8	17.4	10.8	14.6	9.1
		4	23.6	14.7	23.8	14.9	20.0	12.5
		5	29.1	18.2	29.3	18.3	24.7	15.4
		6	35.2	22.0	35.6	22.2	29.9	18.7

The company reserves the right to change the specifications without notice

IMPLEMENT LIMITATIONS

The KUBOTA Tractor has been thoroughly tested for proper performance with implements sold or approved by KUBOTA. Use with implements which are not sold or approved by KUBOTA and which exceed the maximum specifications listed below, or which are otherwise unfit for use with the KUBOTA Tractor may result in malfunctions or failures of the tractor, damage to other property and injury to the operator or others. [Any malfunctions or failures of the tractor resulting from use with improper implements are not covered by the warranty.]

Tread (max. width) with farm tire		Lower link end max. lifting capacity: W 0
Front	Rear	
1050 mm (41.3 in.)	1385 mm (54.5 in.)	2300 kg (5071 lbs.)

Implement weight: W 1	Max. drawbar Load: W 2	Trailer loading weight: W 3
As in the following list (Shown on the next page)	1000 kg (2200 lbs.)	5000 kg (11000 lbs.)

Lower link end max, hydraulic lifting capacity.....W 0
 Implement weight.....The implement's weight which can be put on the lower link: W 1
 Max. drawbar load.....W 2
 Trailer loading weight.....The max. loading weight for trailer: W 3

1AGAI AZAP121B

- NOTE :**
- Implement size may vary depending on soil operating conditions.
 - Strictly follow the instructions outlined in the operator’s manual of the mounted or trailed machinery or trailer, and do not operate the combination tractor - machine or tractor - trailer unless all instructions have been followed
 - Forestry Application
 Following hazards exist;
 - (a) toppling trees, primarily in case a rear-mounted tree grab-crane is mounted at the rear of the tractor;
 - (b) penetrating objects in the operator’s enclosure, primarily in case a winch is mounted at the rear of the tractor.
 Optional equipments such as OPS (Operator Protective Structure), FOPS (Falling Object Protective Structure), etc. to deal with these hazards and other related hazards are not available for this tractor. Without such optional equipment use is limited to tractor specific applications like transport and stationary work.

8 IMPLEMENT LIMITATIONS

No.	Implement		Remarks		M4N-017	M5N-091	M5N-111
					4WD	4WD	4WD
1	Trailer		Max. Load Capacity	kg (lbs.)	5000 (11000)		
			Max. Drawbar Load	kg (lbs.)	1000 (2200)		
2	Mower	Rotary-Cutter	Max. Cutting Width	mm (in.)	2130 (84)		
			Max. Weight	kg (lbs.)	540 (1200)		
		Flail Mower (Heavy)	Max. Cutting Width	mm (in.)	3050 (120)		
			Max. Weight	kg (lbs.)	800 (1760)		
Sickle Bar	Max. Cutting Width	mm (in.)	2130 (84)				
3	Sprayer		Max. Tank-Capacity	Mid	L (gals.)	680 (180)	
				Rear 3P	L (gals.)	680 (180)	
				Drawbar	L (gals.)	4000 (1030)	
4	Rotary Tiller		Max. Tilling Width	mm (in.)	2130 (84)		
			Max. Weight	kg (lbs.)	800 (1760)		
5	Bottom Plow		Max. Size		14 in. x 3 16 in. x 2 18 in. x 1		
			Max. Weight	kg (lbs.) 3P Type	450 (1000)		
6	Disk harrow	3P Type	Max. Size		18 in. x 24		
			Max. Harrowing Width	mm (in.)	2130 (84)		
			Max. Weight	kg (lbs.)	450 (1000)		
		Drawbar Type	Max. Harrowing Width	mm (in.)	2750 (108)		
7	Disc Plow		Max. Size		24 in. x 3 26 in. x 2		
			Max. Weight	kg (lbs.)	450 (1000)		
8	Sub Soiler		Numbers of Cultivating Tines		2		
			Cultivating Depth	mm (in.)	400 (16)		
9	Cultivator		Max. Width	mm (in.)	3660 (144)		
			Number of Rows		4	66	
			Max. Weight	kg (lbs.)	450 (1000)		

NOTE :

- Implement size may vary depending on soil operating conditions.

INSTRUMENT PANEL AND CONTROLS

INSTRUMENT PANEL, SWITCHES AND HAND CONTROLS

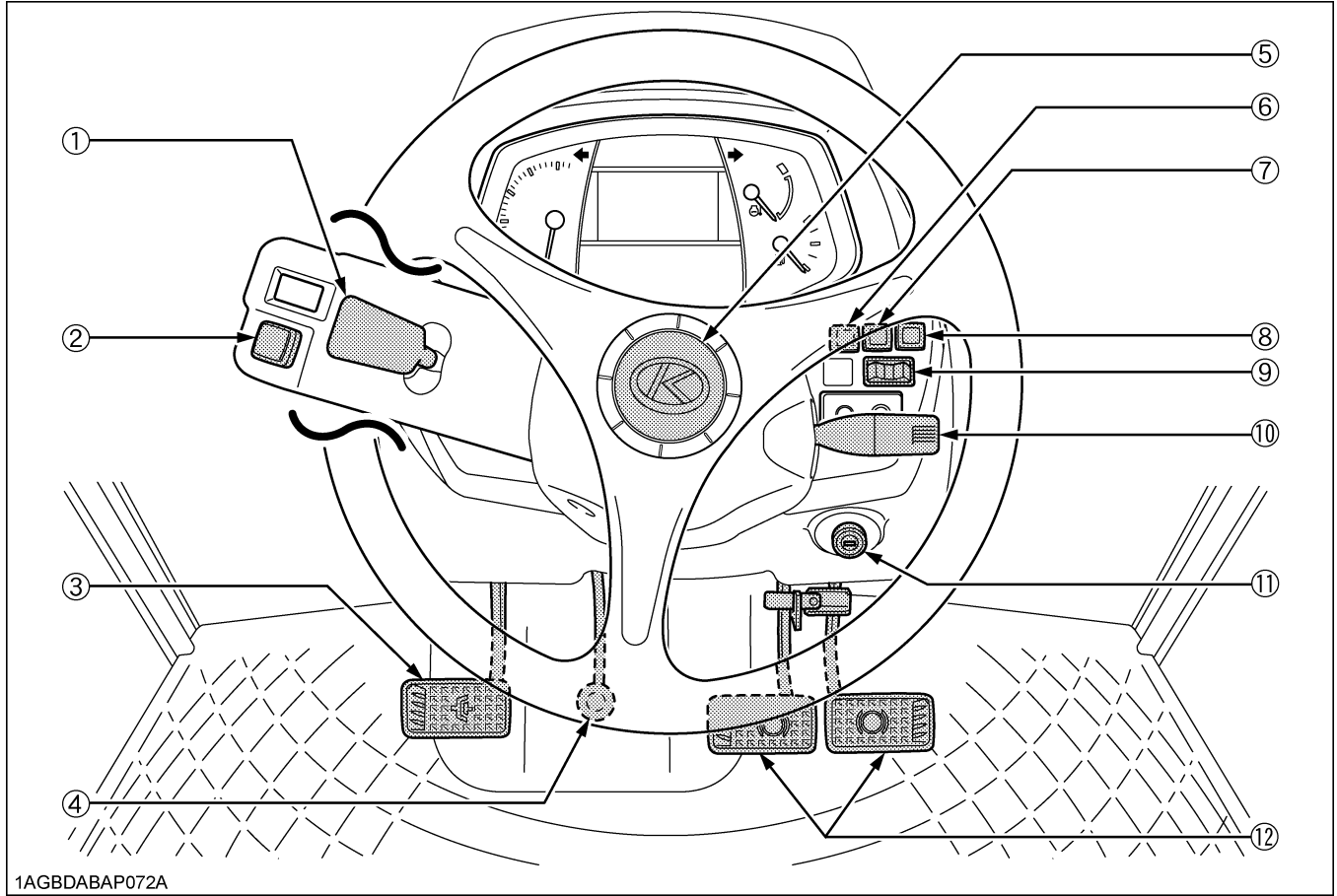

1AGBDABAP072A

ILLUSTRATED CONTENTS

(1) Shuttle shift lever	41
(2) Hazard light switch	36
(3) Clutch pedal	39
(4) Tilt pedal	35
(5) Horn button	37
(6) Constant RPM management switch	55
(7) Parked regeneration switch	20
(8) DPF INHIBIT switch	18
(9) 4WD / Bi-Speed Turn switch	43
(10) Turn signal / Head light switch	36, 36
(11) Key switch	-
(12) Brake pedal	37

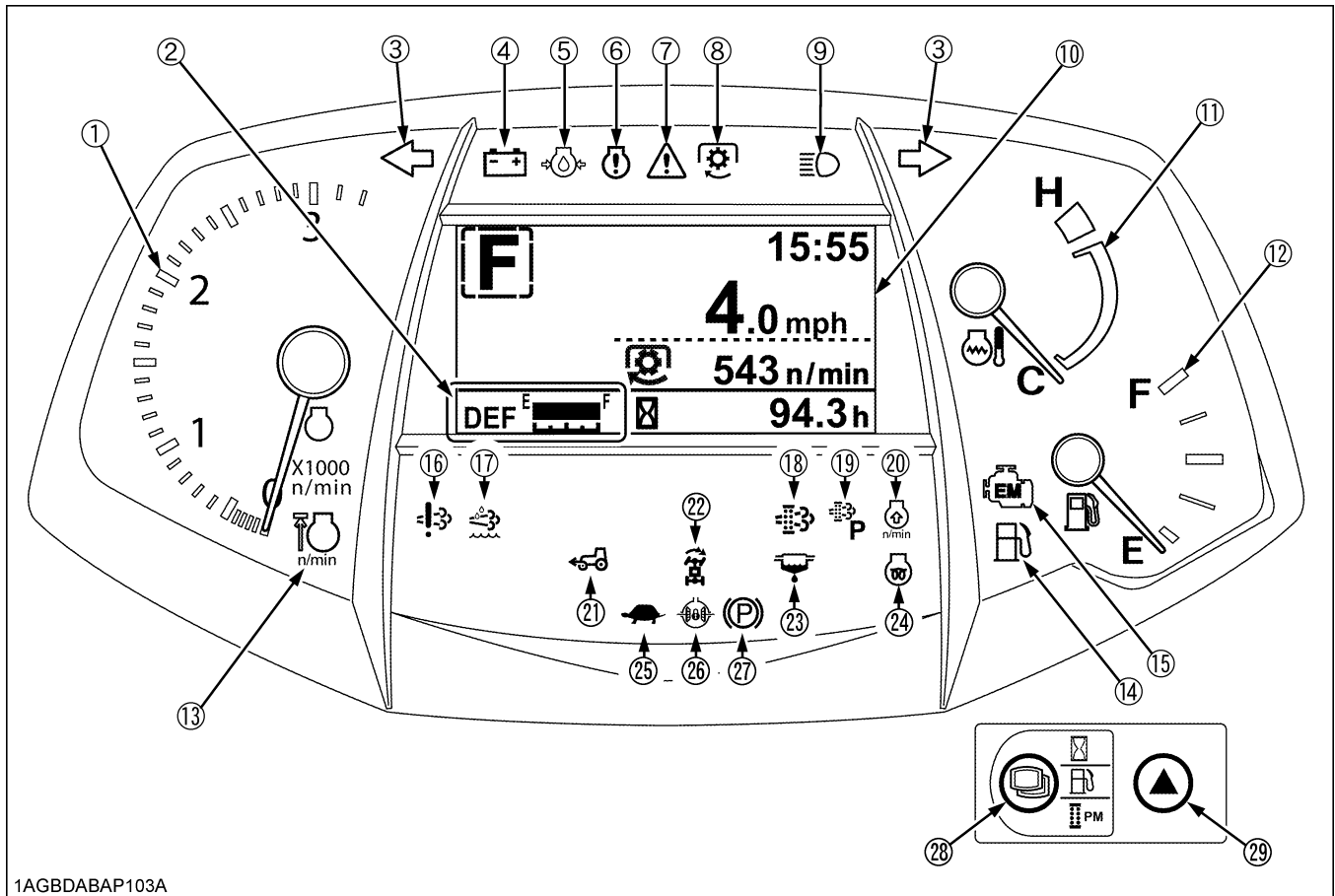

1AGBDABAP103A

ILLUSTRATED CONTENTS

(1) Tachometer	47
(2) DEF/AdBlue® gauge	47
(3) Hazard / Turn signal indicator	36
(4) Electrical charge warning indicator	45
(5) Engine oil pressure warning indicator	45
(6) Engine warning indicator	45
(7) Master system warning indicator	45
(8) PTO clutch indicator	58
(9) High-beam indicator	36
(10) Liquid crystal display	48
(11) Coolant temperature gauge	47
(12) Fuel gauge	46
(13) Rev-limiter indicator	40
(14) Fuel level indicator	45
(15) Emission indicator	45

ILLUSTRATED CONTENTS

(16) DEF/AdBlue® system warning indicator	45
(17) DEF/AdBlue® warning indicator	45
(18) Regeneration indicator	16
(19) Parked regeneration indicator	20
(20) Engine RPM increase indicator	16
(21) 4WD indicator	43
(22) Bi-speed turn indicator	43
(23) Water separator indicator	45
(24) Heater indicator	30
(25) Dual speed shift indicator [Dual speed model].	41
(26) Differential lock indicator.....	56
(27) Parking brake warning indicator	27
(28) Mode selector switch	49
(29) Select switch	49

NOTE :

- Items 2, 16, 17 and 25 correspond only to the M5N-091 and M5N-111 tractor models.

FOOT AND HAND CONTROLS

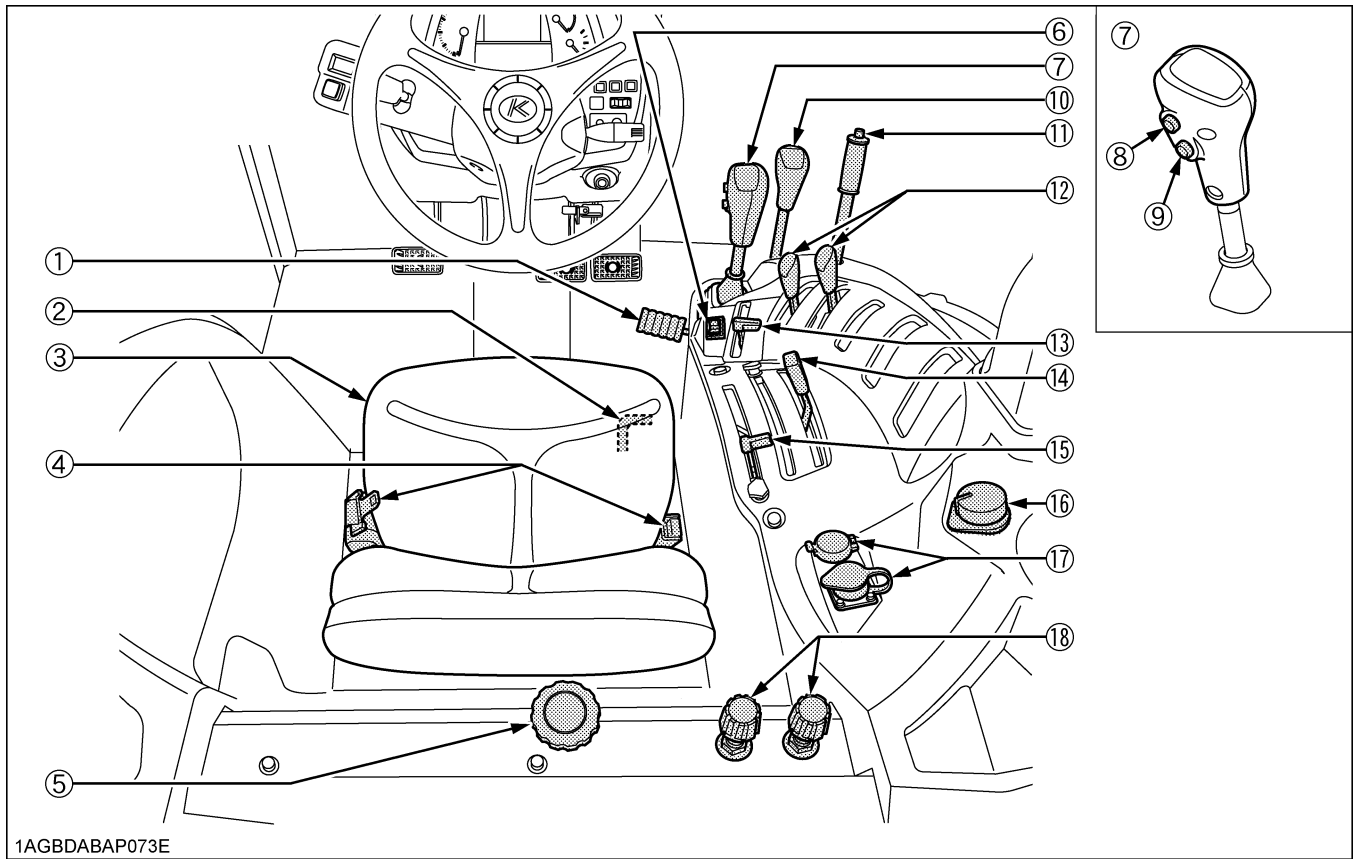

1AGBDABAP073E

ILLUSTRATED CONTENTS

(1) Foot throttle	44
(2) Differential lock pedal	56
(3) Operator's seat	34
(4) Seat belt	35
(5) 3-Point hitch lowering speed knob	68
(6) RPM dual memory switch	53
(7) Main gear shift lever	41
(8) Clutch off switch [Dual speed model]	42
(9) Dual speed shift switch [Dual speed model]	41

ILLUSTRATED CONTENTS

(10) Range gear shift lever	41
(11) Parking brake lever	27, 55
(12) Remote control valve lever	69
(13) Hand throttle lever	44
(14) Position control lever	67
(15) Draft control lever	67
(16) PTO clutch control switch	58
(17) Electrical outlet	87
(18) Flow control knob.....	70

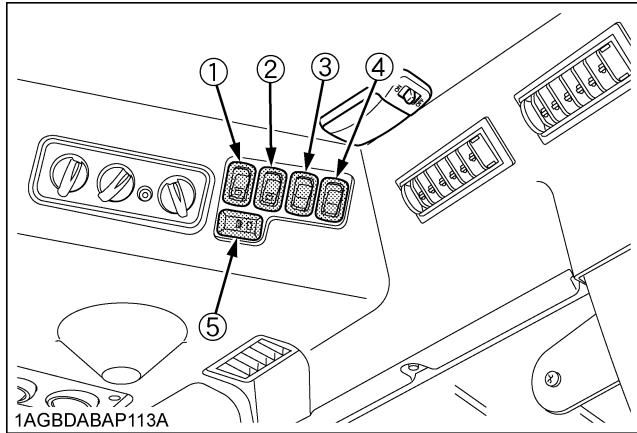

ILLUSTRATED CONTENTS

(1) Rear work light switch.....	80
(2) Front work light switch	80
(3) Rear wiper / Washer switch (if equipped)...	81
(4) Front wiper / Washer switch.....	81
(5) Rear / side defogger switch (if equipped) ...	86
(6) Remote control valve coupler	70
(7) Trailer electrical outlet	57
(8) PTO gear shift lever.....	59

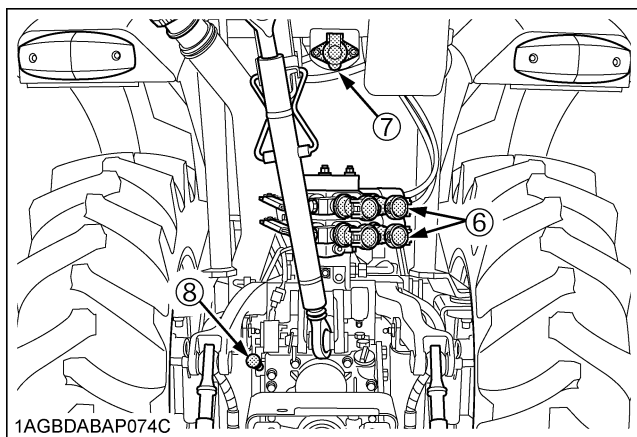

PRE-OPERATION CHECK

DAILY CHECK

To prevent trouble from occurring, it is important to know the condition of the tractor well. Check it before starting.



WARNING

To avoid personal injury or death:

- **Be sure to check and service the tractor on a level surface with the engine shut off and the parking brake "ON" and implement lowered to the ground.**

Check item

- Walk around inspection
- Check engine oil level
- Check transmission oil level
- Check coolant level
- Check washer liquid level
- Check water separator
- Clean grill and radiator screen
- Clean air conditioner condenser screen
- Clean intercooler
- Clean fuel cooler
- Clean oil cooler
- Check DPF/SCR muffler
- Check air cleaner evacuator valve
(When used in a dusty place)
- Check air cleaner dust indicator
(When used in a dusty place)
- Check brake pedal
- Check parking brake lever
- Check indicators, gauges and meter
- Check lights
- Check seat belt
- Check movable parts
- Supply DEF/AdBlue®
- Refuel
(See "DAILY CHECK" in "PERIODIC SERVICE" section.)
- Care of danger, warning and caution labels
(See "DANGER, WARNING AND CAUTION LABELS" in "SAFE OPERATION" section.)

OPERATING THE ENGINE



WARNING

To avoid personal injury or death:

- Read and understand "Safe Operation" in the front of this manual.
- Read and understand the danger, warning and caution labels located on the tractor.
- To avoid the danger of exhaust fume poisoning, do not operate the engine in a closed building without proper ventilation.
- Never start engine while standing on ground. Start engine only from operator's seat.
- Make it a rule to set all shift levers to the "NEUTRAL" positions and to place PTO clutch control switch in "OFF" position before starting the engine.

IMPORTANT :

- Do not use starting fluid or ether.
- To protect the battery and the starter, make sure that the starter is not continuously turned for more than 10 seconds.

EXHAUST AFTERTREATMENT DEVICES



WARNING

To avoid personal injury or death:

- During Diesel Particulate Filter (DPF) regenerating operations, exhaust gases and exhaust filter components reach temperatures hot enough to burn people, or ignite or melt common materials.
- Keep tractor away from people, animals or structures which may be susceptible to harm or damage from hot exhaust gases.
- During regeneration, white exhaust gases may be visible. Do not allow regeneration in a non ventilated garage or confined area.
- During regeneration, do not leave the tractor.

NOTE :

- Exhaust aftertreatment devices vary depending on the model. In accordance with the table below, refer to the appropriate item.

Model	Exhaust aftertreatment device
M4N-071	DPF muffler only
M5N-091 M5N-111	DPF and SCR muffler

■ Dual Exhaust Aftertreatment Devices

Particulate matter (PM) and black smoke contained in exhaust gases are trapped and removed by the DPF (Diesel Particulate Filter) muffler.

The SCR system then decomposes residual nitrogen oxides (NOx) into harmless nitrogen (N₂) and water (H₂O) for purification.

This dual exhaust gas purifying device provides for clean exhaust gas at low fuel consumption.

DIESEL PARTICULATE FILTER (DPF) MUFFLER

This tractor is equipped with an engine with a DPF (Diesel Particulate Filter) muffler which serves to reduce hydrocarbons, carbon monoxide and other gases, all of which are contained in diesel engine emissions, to harmless carbon dioxide and water. The DPF also traps PM (particulate matter).

Please handle exhaust aftertreatment devices correctly and in an environmentally responsible manner.

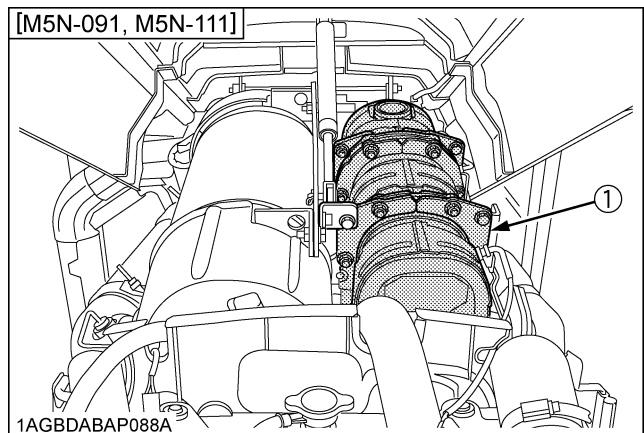
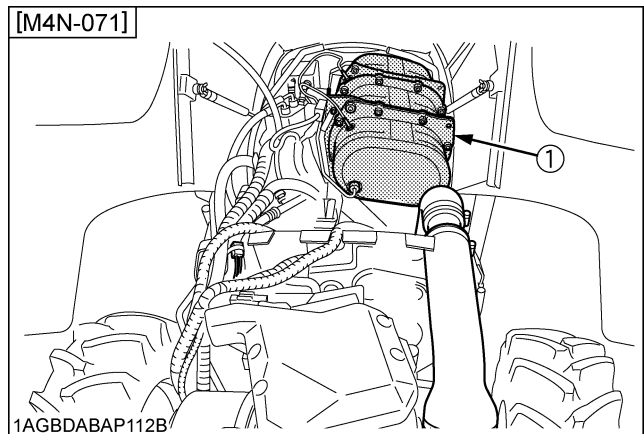

(1) Diesel Particulate Filter (DPF)

■ Handling Points

When a specific amount of PM (particulate matter) has accumulated in the DPF muffler, it is necessary to refresh the DPF muffler by burning the PM inside it. This burning off work is called "Regeneration".

To extend operating time to reach this regeneration, and to avoid DPF muffler trouble, make sure to observe the following handling matters.

◆ Fuel

Be sure to use Ultra Low Sulfur Fuel (S15).

IMPORTANT :

- Use of diesel fuel other than Ultra Low Sulfur Fuel may adversely affect the engine and DPF performance.
Use of fuels other than Ultra Low Sulfur Fuel (S15) may not meet regulations for your region.

◆ Engine oil

Use DPF-compatible oil (CJ-4) for the engine.

IMPORTANT :

- If any engine oil other than CJ-4 is used, the DPF may become clogged earlier than expected and the fuel economy may drop.

◆ Prohibition of unnecessary idling operation

Generally, the lower the engine speed, the lower the exhaust gas temperature is, so the PM contained in exhaust gas will not be burnt, and begins to accumulate. Therefore, don't idle unnecessarily.

◆ Regeneration

When there is "Regeneration" instruction sign by lamp or buzzer, immediately perform the required procedure for regeneration.

IMPORTANT :

- Interrupting the regeneration cycle or continued operation by ignoring the warning signs may cause DPF and engine damage.

■ DPF Regeneration Process

DPF regeneration process can be performed by choosing from "Auto Regeneration" or "Regeneration inhibit" mode according to your job conditions. For jobs not affected by hot gases emitted during regeneration, the "Auto Regeneration" is advisable.

◆ Auto Regeneration Mode;

When starting the engine (switch operation is unnecessary), the "Auto Regeneration" mode is automatically activated.

With the auto regeneration mode on, when a specific amount of PM has accumulated, and the regeneration conditions are satisfied (See the "Tips on Diesel Particulate Filter [DPF] Regeneration"), the DPF will be automatically regenerated whether the tractor is in motion or parked.

By this way, work efficiency is improved. For details of auto regeneration, refer to "Operating Procedure for Auto Regeneration Mode" section.

◆ Regeneration Inhibit Mode;

After starting the engine, if the "DPF INHIBIT switch" is pressed to turn on the switch lamp, the "Regeneration inhibit" mode will be activated.

With "Regeneration Inhibit" mode on, the PM which has accumulated inside the DPF will not be burnt, unless the operator performs the regeneration work manually.

The "Regeneration Inhibit" mode is effective for work in poorly ventilated work spaces.

For details of regeneration prohibition, refer to "Operating Procedure for Regeneration Inhibit Mode" section.

NOTE :

- If stop the engine once, the "Auto Regeneration" mode will be activated.
-

■ Operating Procedure for Auto Regeneration Mode

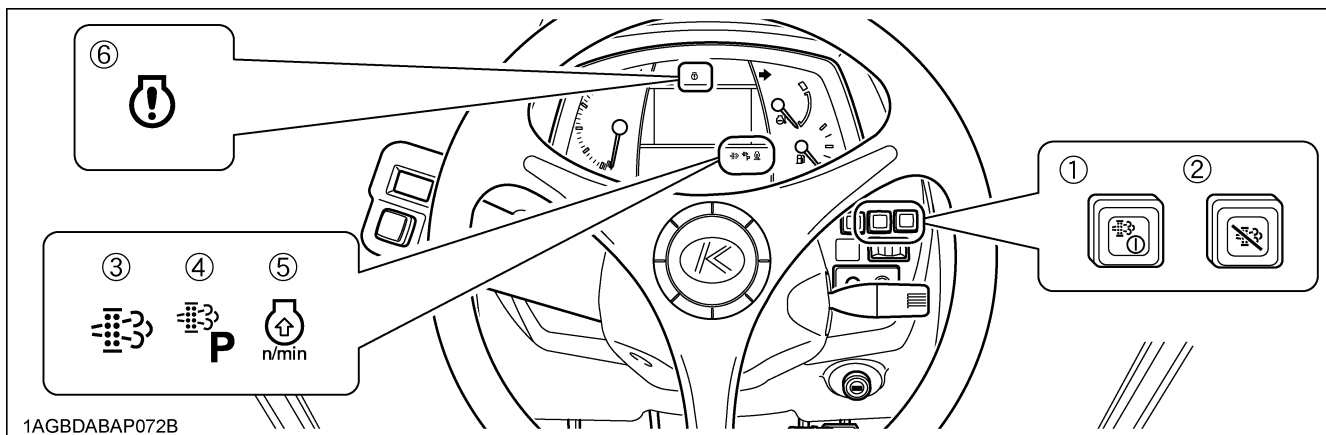

(1) Parked regeneration switch
(2) DPF INHIBIT switch

(3) Regeneration indicator
(4) Parked regeneration indicator

(5) Engine RPM increase indicator
(6) Engine warning indicator

◆ Regeneration Operating Procedure

1. Start the engine.
(Make sure that the DPF INHIBIT switch lamp  is "OFF".)

Switch lamp OFF: Auto Regeneration Mode activated.

Switch lamp ON: Regeneration Inhibit Mode activated.

NOTE :

- When the engine is started, the "Auto Regeneration" mode is automatically activated.
- "Regeneration Inhibit" mode is activated, when the DPF INHIBIT switch is pushed after the engine is started.

2. When the regeneration indicator  starts flashing:

A specific amount of PM has built up in the DPF.

Continue to operate the tractor, and the regeneration process will begin automatically, make sure the working place is in a safe area as DPF and exhaust temperature will rise.

3. When the engine rpm increase indicator  starts flashing:

Keep on working and increase the engine rpm until the indicator turns "OFF".

NOTE :









- Even if the Auto Regeneration Mode is selected, DPF regeneration may not begin because system requirements have not been satisfied.
- The engine rpm increase indicator is used as a guide to satisfy the regeneration conditions. If the engine load is too heavy, the engine rpm increase indicator may continue to flash, even though regeneration system conditions are satisfied and regeneration may begin automatically. (See the "Tips on Diesel Particulate Filter [DPF] Regeneration")

◆ PM Warning Level and Required Procedures

During Auto Regeneration Mode when the PM level has built up in the DPF, the regeneration cycle will begin automatically. If the regeneration cycle is interrupted or the regeneration conditions are not satisfied, the buzzer starts sounding and the indicator display changes in response to the PM level in order to prompt the operator to perform the required procedure listed below.

IMPORTANT :

- Once the regeneration level has been reached, immediately perform the required procedure for regeneration. Interrupting the regeneration cycle or continued operation by ignoring the warning signs may cause DPF and engine damage.

Auto Mode		
	DPF system status	Required procedure
PM warning level: 1 Buzzer: Not sounding	 The regeneration indicator starts flashing.  The RPM increase indicator starts flashing.  The regeneration indicator will stop flashing and remain "ON" constantly.	A specific amount of PM has accumulated in the DPF muffler. Continue to work the tractor to raise the DPF temperature. Continue the work and increase the engine rpm until the indicator turns "OFF". The regeneration cycle begins and continues until cycle is complete then the indicator will turn "OFF".
PM warning level: 2-1 Buzzer: Sounding every 5 seconds	If the regeneration cycle was interrupted or conditions are not satisfied for regeneration then DPF system is now in Level 2.  The regeneration indicator starts flashing.	Start the regeneration, referring to PM warning level: 1 above. Now the parked regeneration indicator starts flashing, and the parked regeneration can also be started. If the regeneration conditions are not met, perform the parked regeneration. ● For the procedure, refer to "Operating Procedure for Parked Regeneration".
PM warning level: 2-2 Buzzer: Sounding every 3 seconds	 The RPM increase indicator starts flashing.  The parked regeneration indicator starts flashing.	
PM warning level: 3 Buzzer: Sounding every 1 second Engine output: 50%	If the regeneration fails in the warning level 2:  The engine warning indicator starts flashing.  The parked regeneration indicator starts flashing.	Immediately discontinue working the tractor and begin the parked regeneration cycle process. ● For the procedure, refer to "Operating Procedure for Parked Regeneration". At this PM warning level, the Auto Regeneration Mode does not function. If the tractor is operated further, the regeneration cycle will be disabled.
PM warning level: 4 Buzzer: Sounding every 1 second Engine output: 50%	If the parked regeneration is interrupted or the tractor is continuously operated in the warning level 3:  The engine warning indicator remains constantly "ON".	Immediately move the tractor to a safe place and park it there and turn the engine "OFF". Contact your local KUBOTA Dealer. ● At this level, never continue to operate the tractor otherwise damage will result to the DPF and engine.

■ Operating Procedure for Regeneration Inhibit Mode

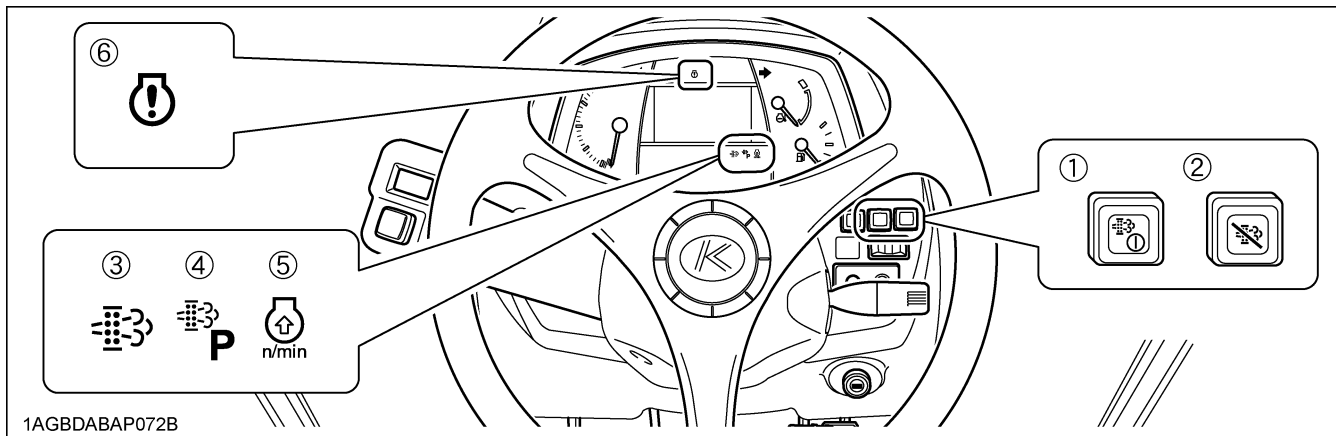

(1) Parked regeneration switch
(2) DPF INHIBIT switch

(3) Regeneration indicator
(4) Parked regeneration indicator

(5) Engine RPM increase indicator
(6) Engine warning indicator

◆ Regeneration Operating Procedure

1. Start the engine.

2. Press the DPF INHIBIT switch , and the switch lamp illuminates.

Switch lamp ON: Regeneration Inhibit Mode selected.
Switch lamp OFF: Auto Regeneration Mode selected.

3. When the parked regeneration indicator  starts flashing:







A specific amount of PM has accumulated in the DPF muffler.
Move the tractor to a safe place and activates the DPF muffler. Follow the "Operating Procedure for Parked Regeneration" procedure.

◆ PM Warning Level and Required Procedures





In the Regeneration Inhibit Mode, the buzzer starts sounding and the indicator display changes in response to the PM level in order to prompt the operator to perform the required procedure listed below.

IMPORTANT :

- Once the regeneration level has been reached, immediately perform the required procedure for regeneration. Interrupting the regeneration cycle or continued operation by ignoring the warning signs may cause DPF and engine damage.

Regeneration Inhibit Mode		
DPF system status		Required procedure
PM warning level: 1 Buzzer: Not sounding	 The regeneration indicator starts flashing.	A specific level of PM has built up in the DPF muffler. Continue with the operation as it is.
	 At PM warning levels range from 1 to 2-2, it is also possible to change DPF INHIBIT switch to auto regeneration mode then perform regeneration.	
PM warning level: 2-1 Buzzer: Sounding every 5 seconds	 The regeneration indicator starts flashing.	Move the tractor to a safe area, then follow the "Operating Procedure for Parked Regeneration".
PM warning level: 2-2 Buzzer: Sounding every 3 seconds	 The Parked regeneration indicator starts flashing.	
PM warning level: 3 Buzzer: Sounding every 1 second Engine output: 50%	If the parked regeneration cycle is interrupted or the tractor is continuously operated in the PM warning level 2:  The engine warning indicator starts flashing.  The parked regeneration indicator starts flashing	Immediately stop working the tractor, move the tractor to a safe area, then follow the "Operating Procedure for Parked Regeneration". If the tractor is operated further and the operator ignores the warning signs, then regeneration will be disabled.
PM warning level: 4 Buzzer: Sounding every 1 second Engine output: 50%	If the regeneration cycle is interrupted or the tractor is continuously operated ignoring the warning signs, in the PM warning level 3:  The engine warning indicator remains constantly "ON".	Immediately move the tractor to a safe place and place in park, turn "OFF" engine. Contact your local KUBOTA Dealer. <ul style="list-style-type: none"> ● At this level never continue to operate the tractor, otherwise damage may result to the DPF and engine.

Operating Procedure for Parked Regeneration

1. Park the tractor in a safe area away from buildings, people, and animals.
2. Apply the parking brake.
3. Set the shuttle shift lever to the neutral position.
4. Turn "OFF" the PTO clutch control switch.
5. Return the engine rpm to the idle speed.
6. Lower the implement to the ground.
7. Press the DPF INHIBIT switch , and the switch lamp turns "OFF".
8. When the regeneration conditions are satisfied (2 to 5 and 7 mentioned above), the parked regeneration switch lamp  start flashing.
9. Press the parked regeneration switch  to start the regeneration cycle.
(The switch lamp will stop flashing and remain "ON" constantly during the cycle.)
10. The engine rpm will automatically rise, and the regeneration process will begin.
11. Both indicators   stay "ON" while regenerating the DPF.
They turn "OFF" when the cycle is complete.
12. After the lamp turns "OFF", normal tractor work may resume.
When driving in "Regeneration Inhibit" mode, press the DPF INHIBIT switch to turn on the switch lamp.

NOTE :

- During the regeneration cycle, do not touch the above levers, and switches (in steps 2, 3, 4), nor change the engine rpm other than an emergency stop. Otherwise, the regeneration will be interrupted.
 - Never leave the tractor when parked regeneration process is activated.
 - If the parked regeneration cycle is interrupted, the engine rpm is fixed at the idling level for about 30 seconds. For this period, keep the hand throttle lever and foot throttle pedal at the idle position. Do not move them. They will function again in 30 seconds.
-

■ Tips on Diesel Particulate Filter (DPF) Regeneration

● Operation

The higher in speed or load the engine operates, the higher the exhaust temperature rises. As a result, particulate matter (PM) inside the DPF is consumed, therefore the regeneration process is required less frequently over time.

The lower in speed or load the engine operates, the lower the exhaust temperature. Accordingly, less particulate matter (PM) inside the DPF is consumed, therefore more accumulation of PM will occur, which requires frequent regeneration, therefore avoid prolonged idling if possible.

● Necessary conditions for "Regeneration"

When conditions below are all satisfied, regeneration will start. However, if even one condition is deviated during the process, the regeneration will be interrupted.

- (1) The engine coolant temperature.
- (2) The DPF temperature.
- (3) The engine speed is 1200 rpm or higher.

- Usually it takes 15-20 minutes to complete the regeneration cycle.

Actual regeneration time may depend on ambient temperature, exhaust temperature and engine speed.

- It is recommended to do the regenerating while the engine is warm.
- Do not unnecessarily start and interrupt the regeneration process. Otherwise, a small amount of fuel becomes mixed with the engine oil, which degrades the oil quality.
- While the DPF is being regenerated, the engine air flow rate is automatically limited to keep up the exhaust temperature. Because of this the engine may sound differently, this is normal for this engine.
- Just after the regeneration has ended, the DPF muffler remains hot. It is advisable to keep the engine running for about 5 minutes to allow cooling of the exhaust components.

SELECTIVE CATALYTIC REDUCTION (SCR) MUFFLER

■ Outline of the SCR

The injector jets urea aqueous solution (DEF/AdBlue®) into the muffler, and the solution is hydrolyzed with the heat of exhaust gas to generate ammonia (NH₃).

The ammonia generated thus is mixed with exhaust gas by the SCR muffler. In this way, nitrogen oxides (NO_x) contained in exhaust gases are reduced by ammonia and decomposed into nitrogen and water vapor.

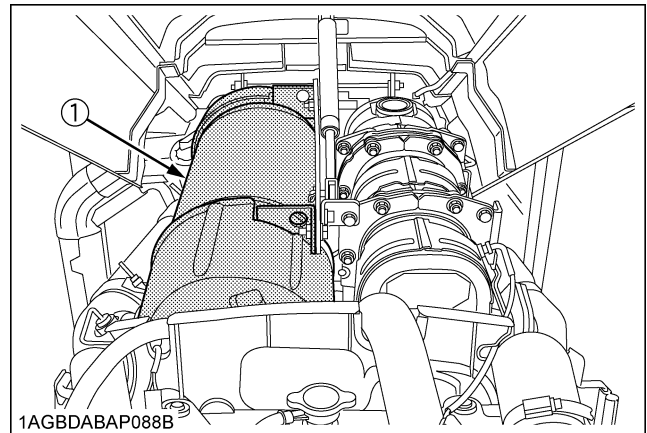

(1) SCR muffler

■DEF/AdBlue®

CAUTION

To avoid personal injury:

- The urea aqueous solution (DEF/AdBlue®) is colorless, odorless and harmless. If the solution gets on your skin, immediately wash it away with water.

The DEF/AdBlue®, used as reducing agent of SCR, is a 32.5% urea aqueous solution.

No qualification for handling the urea aqueous solution is needed. As well, the solution is not designated as a hazardous material.

The product is available at gas stations, truck stops and specialty shops. Be sure to use the genuine product only. Do not use any poor-quality products, or the engine may have trouble and be damaged.

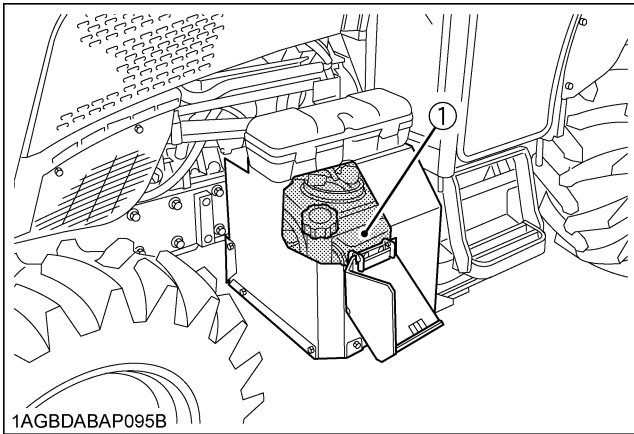

(1) DEF/AdBlue® tank (Blue cap)

NOTE :

- On the North American market, the high-grade NOx reducing agent called urea aqueous solution is sold in the name of DEF (Diesel Exhaust Fluid). On the European and Japanese markets, it is on sale under the trade name of AdBlue®.

■Warning Indication and its Countermeasure

Before starting the day's job, check the fluid level with the DEF/AdBlue® gauge on the instrument panel.

If the fluid runs short during operation, the warning indicator lights up. If you continue running the machine as it is, the engine output will be limited by 50% or so. If running is continued, the engine will be limited to idling. For details, look at the table below.

These limitations are stipulated in conformity with the emission controls of each country and territory.

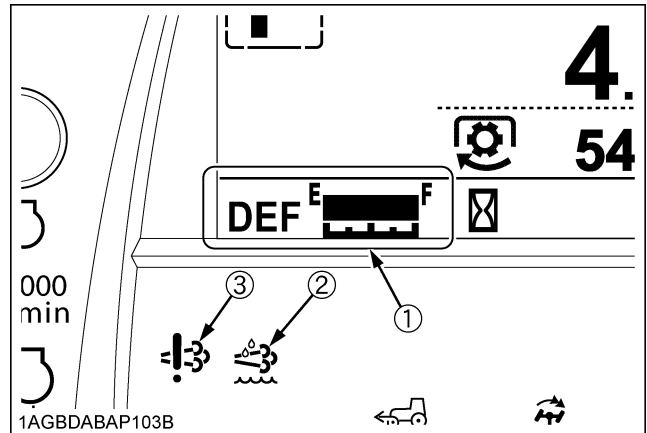

- (1) DEF/AdBlue® gauge
- (2) DEF/AdBlue® warning indicator
- (3) DEF/AdBlue® system warning indicator

◆ SCR system inducement display on the LCD

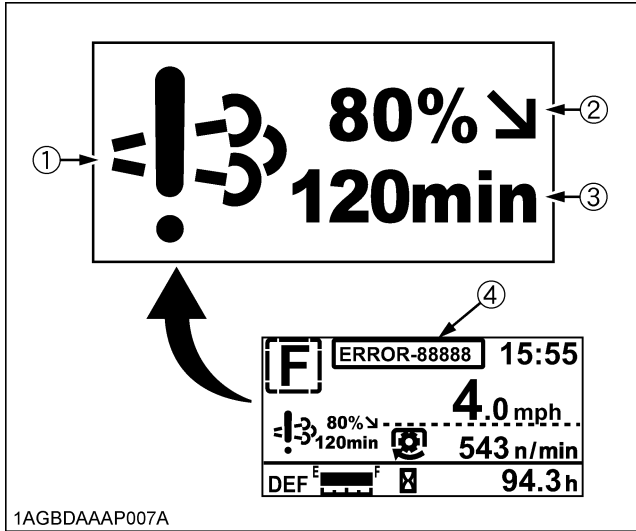

1AGBDAAAP007A

- (1) SCR system icon
- (2) Engine output level
- (3) Time limit to next level or remaining DEF/AdBlue®
- (4) Performance monitor (Error code and DTC)

◆ SCR system icon appearing on inducement display

	Low-level icon of DEF/AdBlue®		Trouble icon of SCR system
	Poor-quality icon of DEF/AdBlue®		Freeze icon of DEF/AdBlue®

◆ DTC (Diagnostic Trouble Code)

DTC can be used to diagnose the problem in engine and SCR muffler.

(e.g P208B: The code beginning with the letter "P" or "U" is the DTC)

If a DTC appears, immediately contact your local KUBOTA Dealer.

NOTE :















- When operating in cold weather, the DEF/AdBlue® is automatically thawed while the engine is running. However, in weather conditions of under -30 °C (-22 °F), the DEF/AdBlue® cannot be completely thawed and thus, a DTC(P208B) appears on the instrument panel's LCD screen.

If the DTC(P208B) appears on the screen, stop the engine and restart it after 10 seconds. After restarting the engine, the DTC(P208B) will disappear and the thawing of the DEF/AdBlue® will resume.











In case the DTC(P208B) remains on the screen even after restarting the engine several times, contact your local KUBOTA Dealer.

◆ For SCR system inducement display appearing on LCD, refer to measures of the table below.

On the SCR system, the remaining amount and quality of DEF/AdBlue® as well as machine troubles are monitored. If anything goes wrong during operation, the following warnings are issued. Follow the warning contents to take proper measures.

Displays	Warning indicator	Status	Measures	DPF Parked Regeneration
 15%		1	The amount of remaining DEF/AdBlue® has decreased up to 15% of the maximum capacity. Refuel the DEF/AdBlue® tank to reset the warning system. If operation is continued without refueling, the engine output will be limited.	permit
 Lv.1		2	The amount of remaining DEF/AdBlue® has decreased up to 5% of the maximum capacity. Refuel the DEF / AdBlue® tank. (*1) The engine output is limited to 50% (Lv.1: Level.1). If operation is continued without refueling, the engine output will be limited to Idle Status (Lv.2:Level.2).	inhibit
 Lv.1 25min		2	The amount of remaining DEF/AdBlue® has decreased up to 5% of the maximum capacity. Refuel the DEF / AdBlue® tank. (*1) The engine output is limited to 50% (Lv.1: Level.1). If operation is continued without refueling, after 25 minutes, the engine output will be limited to Idle Status (Lv.2:Level.2).	inhibit
 Lv.2		3	The amount of remaining DEF/AdBlue® has decreased up to 5% of the maximum capacity. The engine output will remain limited. Refuel the DEF / AdBlue® tank. (*1) The engine output is limited to Idle Status (Lv.2:Level.2).	inhibit
 60min		1	Contains poor quality DEF/AdBlue® or other non-regulated solutions. After draining the tank, refuel with DEF/AdBlue® to reset the warning system. If operation is continued without refueling the DEF/AdBlue® tank, after 60 minutes, the engine output will be limited to 50% (Lv.1:Level.1).	permit
 Lv.1 25min		2	Contains poor quality DEF/AdBlue® or other non-regulated solutions. After draining the tank, refuel with DEF/AdBlue®. (*1) The engine output is limited to 50% (Lv.1: Level.1). If operation is continued without refueling the DEF/AdBlue® tank, after 25 minutes, the engine output will be limited to Idle Status (Lv.2:Level.2).	inhibit
 Lv.2		3	Contains poor quality DEF/AdBlue® or other non-regulated solutions. After draining the tank, refuel with DEF/AdBlue®. (*1) The engine output is limited to Idle Status (Lv.2:Level.2).	inhibit

*1 When DEF/AdBlue® has been added or a poor-quality solution replaced by a genuine product, the low-level warning indicator and icons go off. The engine output limitation will also be cleared.

Displays	Warning indicator	Status	Measures	DPF Parked Regeneration
 120min		1	The SCR system has experienced an abnormality. Verify the DTC displayed on the performance monitor and contact your local KUBOTA dealer. The engine output is unrestricted. After 120 minutes, the engine output will be limited to 50% (Lv.1:Level.1).	inhibit
 80% ↘ 120min		1	The SCR system has experienced an abnormality. Verify the DTC displayed on the performance monitor and contact your local KUBOTA dealer. The engine output is limited to 80%. After 120 minutes, the engine output will be limited to 50% (Lv.1:Level.1).	inhibit
 Lv.1 25min		2	The SCR system has experienced an abnormality. Verify the DTC displayed on the performance monitor and contact your local KUBOTA dealer. The engine output is limited to 50% (Lv.1: Level.1). After 25 minutes, the engine output will be limited to Idle Status (Lv.2:Level.2).	inhibit
 Lv.2		3	The SCR system has experienced an abnormality. Verify the DTC displayed on the performance monitor and contact your local KUBOTA dealer. The engine output is limited to Idle Status (Lv.2:Level.2).	inhibit
	---	---	Due to low temperatures, the DEF/AdBlue® has frozen. Continue the warm-up operation and the DEF/AdBlue® will thaw.	inhibit
 80% ↘	---	---	Due to low temperatures, the DEF/AdBlue® has frozen. The engine output is limited to 80%. Continue the warm-up operation and the DEF/AdBlue® will thaw.	inhibit

NOTE :

- The limited engine output level:
 - Lv.1 (Level 1): Within 50% of max torque and 60% of engine speed.
 - Lv.2 (Level 2): Within engine near idling speed.
 - After an error has occurred, it may be necessary for the engine output to become limited to Lv.2(Level.2). Depending on trouble spots and contents, the indicator-prompted warnings and the engine output limits and timings may vary accordingly.

The SCR warning status (from 1 to 3) represents the severity order of the engine output limitation. If the SCR system experiences abnormalities, an error code will be displayed, and it may be necessary to limit the engine output to Idle Status (Lv.2:Level.2).

(e.g. When a P204F error code is displayed, the engine output changes from unrestricted to Lv.2 limited.)
 - Points after taking measures.

After the engine has stopped and the DEF/AdBlue® has drained, if the amount that was refueled is less than the pre-drain amount, the SCR system may experience a malfunction.(P20F5 error code is displayed)

When the error occurs, turn the key switch to OFF, wait for the SCR system to complete the purge process (this may take several minutes) and then turn the key switch to ON again in order to clear the SCR system malfunction.
 - The 40 hours warning record.
 - (1) Basically Warning and/or inducement reduction cancel when the fault location is repaired.
 - (2) However, if it detects any fault within 40 hours of the restoration, it soon becomes back to the previous failure and the timer restarts counting down.
 - (3) The 40 hours warning record will be reset if any fault has not been detected over 40 hours from the repair.

If a fault would be detected after the 40 hours warning record reset, then the new countdown will be stated.
-

■ Storing and Handling DEF/AdBlue®

1. Because DEF/AdBlue® is a urea aqueous solution, it begins to freeze at ambient temperatures below -11°C (12°F). In winter, handle it with enough care.
2. DEF/AdBlue® may be stored in the tractor's tank for up to 4 months. If the storage area's ambient temperature rises above 30°C (86°F), however, its storage life will be markedly reduced.

◆ Storage method

1. Store the solution in a well-sealed container.
2. Place the container in a location not exposed to direct sunlight.
3. Place the container in a well-ventilated spot.
4. Keep the container in a spot without violent temperature changes.
5. Keep the container away from any containers of gasoline and diesel fuel.

STARTING THE ENGINE

1. Make sure the parking brake is set.

1. To set the parking brake;
 - (1) Depress the brake pedals.
 - (2) Place the shuttle shift lever in neutral position.
 - (3) Pull the parking brake lever to parking position.
2. To release the parking brake;
 - (1) Depress the brake pedals.
 - (2) Push the release button.
 - (3) Shift the lever to transport position.

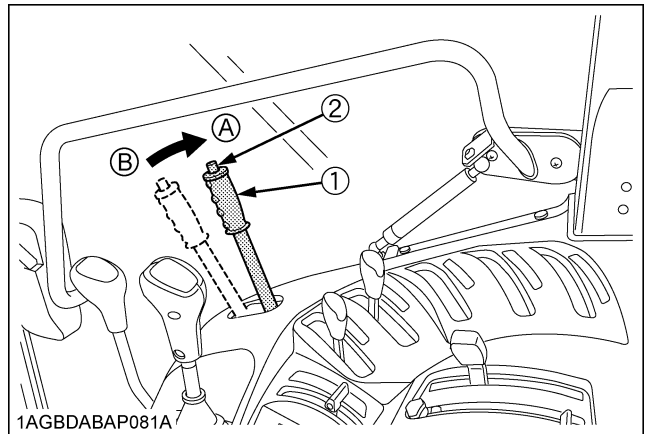

(1) Parking brake lever
(2) Release button

(A) "PARKING POSITION"
(B) "TRANSPORT POSITION"

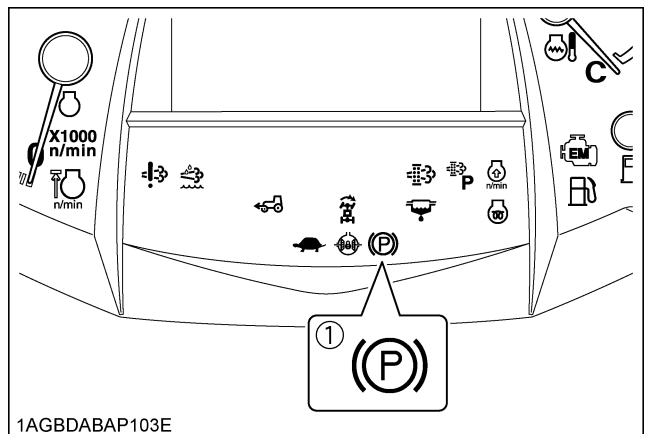

(1) Parking brake warning indicator

IMPORTANT :

- Bring the tractor to a complete stop before applying the parking brake lever.
- If the parking brake lever is moved while the shuttle shift lever is placed in forward or reverse position, an alarm buzzer will sound.

NOTE :

- In moving the parking brake lever, you may feel it heavy some time or light other time. This is not a trouble, however.

2. Make sure the fuel shutoff-valve is in the "OPEN" position.

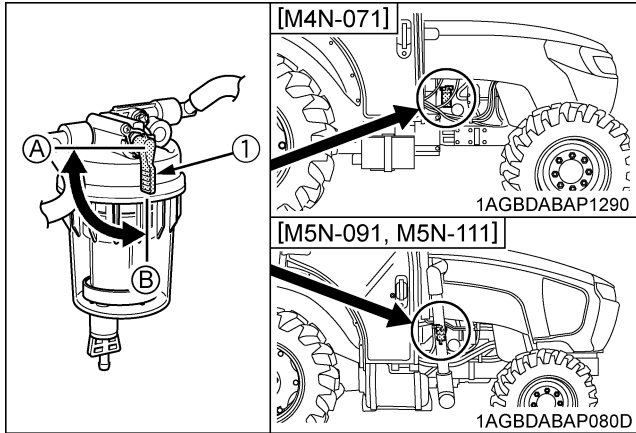

(1) Fuel shutoff-valve
 (A) "CLOSE"
 (B) "OPEN"

3. Place the shift levers in "NEUTRAL" position.

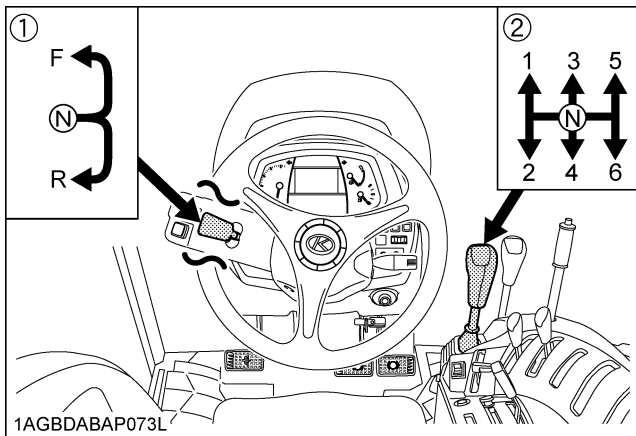

(1) Hydraulic-shuttle shift lever
 (2) Main gear shift lever
 (F) "FORWARD"
 (N) "NEUTRAL POSITION"
 (R) "REVERSE"

4. Place the PTO clutch control switch in "OFF" position and hydraulic control levers in "LOWEST" position.

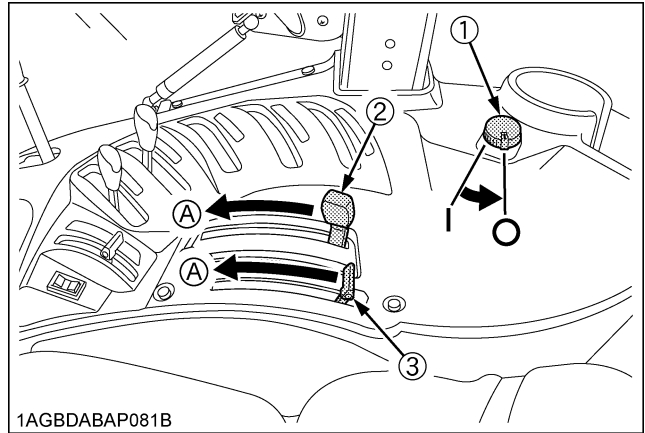

(1) PTO clutch control switch
 (2) Position control lever
 (3) Draft control lever
 | "ON" ○ "OFF"
 (A) "DOWN"

5. Set the throttle lever at the minimum speed position.

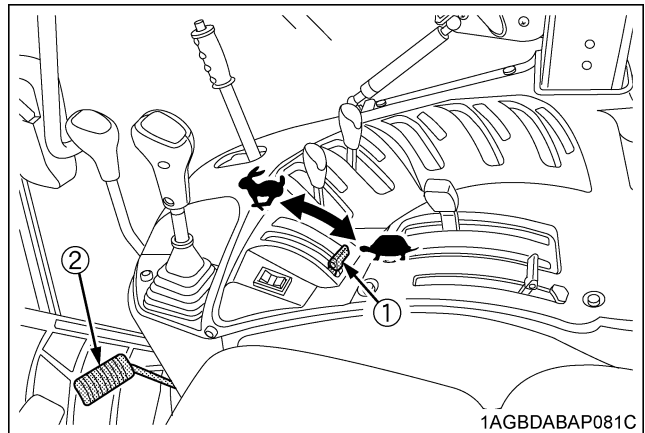

(1) Hand throttle lever
 (2) Foot throttle
 ↑ "INCREASE"
 ↓ "DECREASE"

6. Insert the key into the key switch and turn it "ON".

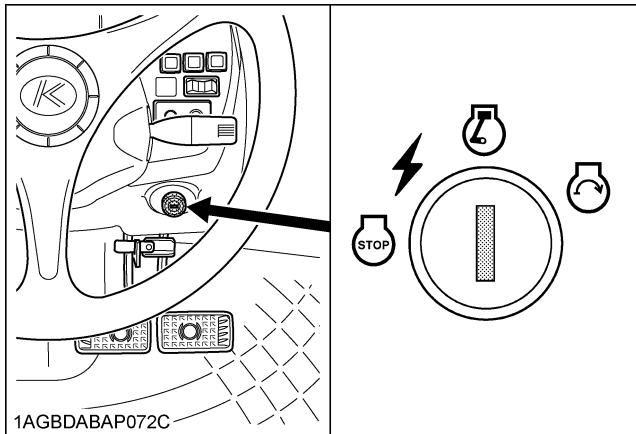

- "OFF" (Engine-Stop)
- "ON" (Engine-Run)
- "ACC" (Electrical Power-accessories)
- "START" (Engine-Start)

NOTE:

- ACC...
- The accessories can be used while the engine is stopped.
 - Do not leave the key at "ACC" position. The battery will be quickly discharged. Turn it back to "OFF" after use.

◆ Check Easy Checker(TM) Indicators:

1. When the key is turned "ON", indicators (1) (2) should come on. If trouble should occur at any location while the engine is running, the indicator corresponding to problem will turn "ON".
2. Suppose that the engine coolant temperature is not high enough yet. The heater indicator (7) also turns "ON" when the key is turned "ON" to preheat the engine and goes off automatically when preheat is completed.
Illumination time of indicator varies according to the temperature of coolant.
3. The PTO clutch indicator (3) comes on while PTO clutch control switch is engaged "ON" and goes off when disengaged.
4. If the fuel level indicator (8) lights up, when fuel level is very low, therefore add fuel and the indicator will turn "OFF".
5. If the DEF/AdBlue® warning indicator (4) lights up, check to see icon on LCD. (See "Warning Indication and its Countermeasure" in "SELECTIVE CATALYTIC REDUCTION (SCR) MUFFLER" in "OPERATING THE ENGINE" section.)

6. If the Water separator indicator (6) lights up, when water in the Water separator is very high, therefore drain the water and the indicator will turn "OFF".
7. If the parking brake warning indicator (5) does not illuminate, set the parking brake.

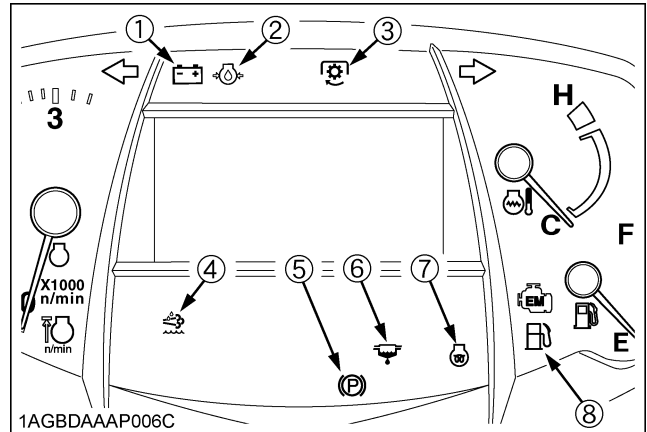

- (1) Electrical charge warning indicator
- (2) Engine oil pressure warning indicator
- (3) PTO clutch indicator
- (4) DEF/AdBlue® warning indicator
- (5) Parking brake warning indicator
- (6) Water separator indicator
- (7) Heater indicator
- (8) Fuel level indicator

NOTE :

- Some of the Easy Checker(TM) indicators may illuminate or start flashing depending on the positions of the levers and switches.
- The DEF/AdBlue® warning indicator corresponds only to the M5N-091 and M5N-111 tractor models.

IMPORTANT :

- Daily checks with the Easy Checker(TM) only, are not sufficient. Never fail to conduct daily checks carefully by referring to Daily Check. (See "DAILY CHECK" in "PERIODIC SERVICE" section.)

7. Fully depress the clutch pedal.

8. Turn the key to "START" position and release when the engine starts.

IMPORTANT :

- Because of the safety devices, the engine will not start except when the PTO clutch control switch is placed in the "OFF" position and shuttle shift lever is placed in the "NEUTRAL" position.

9. Check to see that all the indicators on the Easy Checker(TM) are "OFF".

If an indicator is still on, immediately stop the engine and determine the cause.

10. Release the clutch pedal.

COLD WEATHER STARTING

If the ambient temperature is below 0 °C (32 °F) and the engine is very cold, follow the procedure below after taking the step 1 through 5 in the previous pages.

6. Turn the key to "ON" position and hold it until the heater indicator turns off.

Heater indicator comes on when the key is turned to "ON" position and engine coolant temperature is below 0 °C (32 °F), and goes off automatically when preheat is completed.

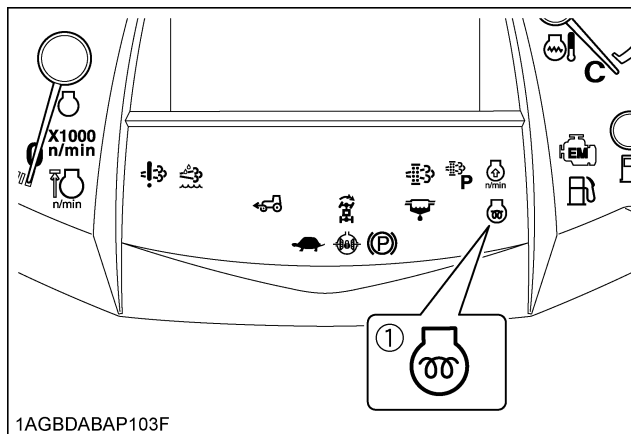

1AGBDABAP103F

(1) Heater indicator

7. Fully depress the clutch pedal.

8. Turn the key to the "START" position and the engine should start.

(If the engine fails to start after 10 seconds, turn off the key for 30 seconds. Then repeat steps 6 through 8. To protect the battery and the starter, make sure that the starter is not continuously turned for more than 10 seconds.)

■ Block Heater (if equipped)

A block heater is available as an option from your dealer. It will assist you in starting your tractor when the ambient temperature is below -20 °C (-4 °F).

■ Engine Low Temperature Regulation

In order to prevent engine damage due to rapid acceleration, if starting the engine when coolant temperature is approximately 0°C (32°F) or below, the engine rpm will be kept at approximately 1400 for up to 3 minutes, and the operator will be informed by indicator and intermittent buzzer. The regulation time varies in response to the coolant temperature.

During regulation, perform warm-up operation without using the accelerator. After regulation, the engine rpm can be gradually increased. When regulation has been completely released, the indicator will go off and the buzzer stop.

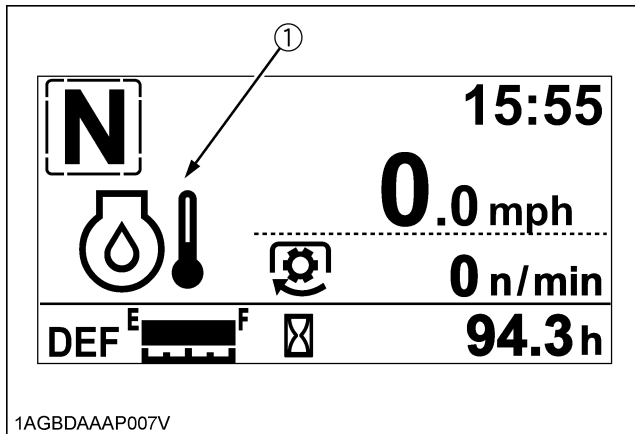

(1) Low temperature regulation indicator

■ DEF/AdBlue® Freeze Warning

[M5N-091, M5N-111]

When operating in cold weather, the DEF/AdBlue® is automatically thawed while the engine is running. However, in weather conditions of under -30°C (-22°F), the DEF/AdBlue® cannot be completely thawed and thus, an error/warning code (P208B) appears on the instrument panel's LCD screen.

If the error/warning code (P208B) appears on the screen, stop the engine and restart it after 10 seconds. After restarting the engine, the error/warning code (P208B) will disappear and the thawing of the DEF/AdBlue® will resume.

In case the error/warning code (P208B) remains on the screen even after restarting the engine several times, contact your local KUBOTA Dealer.

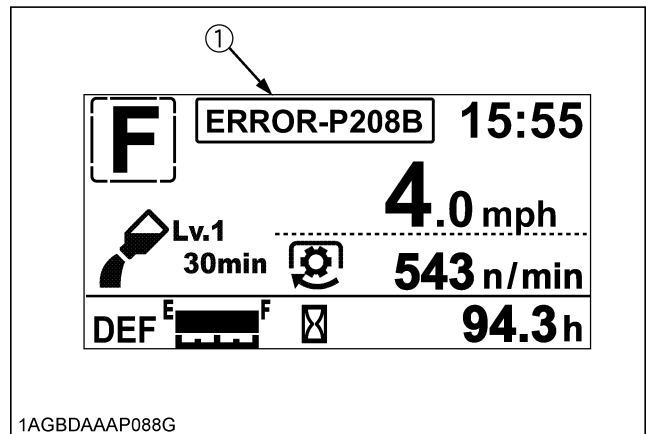

(1) Error/Warning code

STOPPING THE ENGINE

1. After slowing the engine to idle, wait 3 to 5 minutes for turbo to slow down and then turn the key to "OFF".
2. Remove the key.

IMPORTANT [M5N-091, M5N-111]

- When the engine is stopped-shutdown, DEF/AdBlue® flow is reversed in the DEF/AdBlue® lines and related piping and returned back into the DEF/AdBlue® tank after cooling the DEF/AdBlue® injector. The SCR system continues working several minutes after engine shutdown to complete this purge process.
- Do not turn the machine main battery power off to the engine until the DEF/AdBlue® return cycle purge process is completed. Turning off the main battery power to the engine and aftertreatment system prior to completion may damage the system or cause it to malfunction.

NOTE :

- If key does not stop the engine, consult your local KUBOTA Dealer.

WARMING UP



WARNING

To avoid personal injury or death:

- Be sure to set the parking brake during warm-up.
- Be sure to set all shift levers to the "NEUTRAL" positions and to place PTO switch in "OFF" position during warm-up.

For 5 minutes after engine start-up, allow engine to warm up without applying any load, this is to allow oil to reach every engine part. If load should be applied to the engine without this warm-up period, trouble such as seizure, breakage or premature wear may develop.

■ Warm-up and Transmission Oil at Low Temperature Range

Hydraulic oil serves as transmission fluid. In cold weather, the oil may be cold with increased viscosity. This can cause delayed oil circulation or abnormally low hydraulic pressure for some time after engine start-up. This in turn can result in trouble in the hydraulic system.

To prevent the above, observe the following instructions: Warm up the engine at about 50 % of rated rpm according to the table below:

Ambient temperature	Warm-up time requirement
Higher than 0 °C (32 °F)	Approx. 5 minutes
0 to -10 °C (32 to 14 °F)	10 to 20 minutes
-10 to -20 °C (14 to -4 °F)	20 to 30 minutes
Below -20 °C (-4 °F)	More than 30 minutes

IMPORTANT :

- Do not operate the tractor under full load condition until it is sufficiently warmed up.

JUMP STARTING



WARNING

To avoid personal injury or death:

- Battery gases can explode. Keep cigarettes, sparks, and flames away from battery.
- If tractor battery is frozen, do not jump start engine.
- Do not connect the other end of the negative (-) jumper cable to the negative (-) terminal of the tractor battery.

When jump starting the engine, follow the instructions below to safely start the engine.

1. Bring the helper vehicle with a battery of the same voltage as disabled tractor within easy cable reach. "THE VEHICLES MUST NOT TOUCH".
2. Engage the parking brakes of both vehicles and put the shift levers in neutral. Shut both engines off.
3. Wear eye protection and rubber gloves.
4. Attach the red clamp to the positive (red, (+) or pos.) terminal of the dead battery and clamp the other end of the same cable to the positive (red, (+) or pos.) terminal of the helper battery.
5. Clamp the other cable to the negative (black, (-) or neg.) terminal of the helper battery.
6. Clamp the other end to the engine block or frame of the disabled tractor as far from the dead battery as possible.
7. Start the helper vehicle and let its engine run for a few moments. Start the disabled tractor.
8. Disconnect the jumper cables in the exact reverse order of attachment. (Steps 6, 5 and 4)

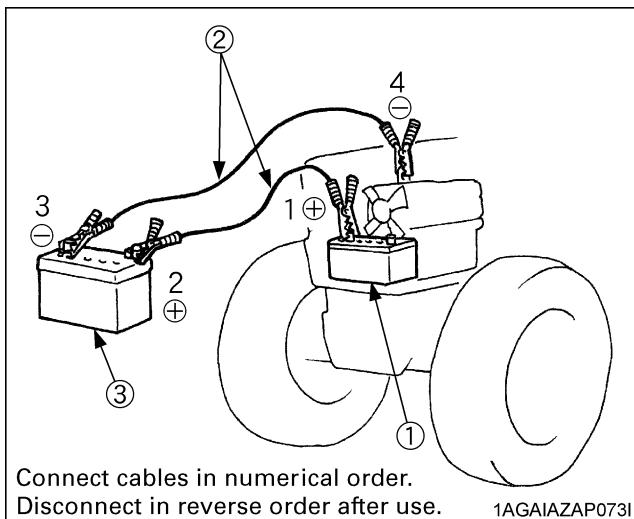

- (1) Dead battery
(2) Jumper cables
(3) Helper battery

IMPORTANT :

- This machine has a 12 volt negative (-) ground starting system.
- Use only same voltage for jump starting.
- Use of a higher voltage source on tractor's electrical system could result in severe damage to tractor's electrical system.
Use only matching voltage source when "Jump starting" a low or dead battery condition.
- Do not operate the tractor with the battery cable disconnected from the battery.
- Do not operate the tractor without the battery mounted.
- Do not operate the tractor with the battery dead. Charge the battery fully enough before operating the tractor.
Otherwise the tractor might malfunction.

OPERATING THE TRACTOR

OPERATING NEW TRACTOR

How a new tractor is handled and maintained determines the life of the tractor.

A new tractor just off the factory production line has been, of course, tested, but the various parts are not accustomed to each other, so care should be taken to operate the tractor for the first 50 hours at a slower speed and avoid excessive work or operation until the various parts become "broken-in". The manner in which the tractor is handled during the "breaking-in" period greatly affects the life of your tractor.

Therefore, to obtain the maximum performance and the longest life of the tractor, it is very important to properly break-in your tractor. In handling a new tractor, the following precautions should be observed.

■ Do not Operate the Tractor at Full Speed for the First 50 Hours.

- Do not start quickly nor apply the brakes suddenly.
- In winter, operate the tractor after fully warming up the engine.
- Do not run the engine at speeds faster than necessary.
- On rough roads, slow down to suitable speeds. Do not operate the tractor at fast speed.

The above precautions are not limited only to new tractors, but to all tractors. But it should be especially observed in the case of new tractors.

■ Changing Lubricating Oil for New Tractors

The lubricating oil is especially important in the case of a new tractor. The various parts are not "broken-in" and are not accustomed to each other; small metal grit may develop during the operation of the tractor; and this may wear out or damage the parts. Therefore, care should be taken to change the lubricating oil a little earlier than would ordinarily be required.

For further details of change interval hours.
(See "MAINTENANCE" section.)

BOARDING AND LEAVING THE TRACTOR

1. Never try to get on or off a moving tractor or jump off the tractor to exit.
2. Face the tractor when getting into or out of the tractor. Do not use the controls as hand holds to prevent inadvertent machine movements.
3. Always keep steps and floor clean to avoid slippery conditions.

STARTING

1. Adjusting the Operator's Position.

NOTE :

- The seat and suspension should be adjusted to ensure that the controls are comfortably at hand for the operator, ensuring that the operator maintains a good posture and minimizes risks from whole body vibration.

■ Operator's Seat



WARNING

To avoid personal injury or death:

- Make adjustments to the seat only while the tractor is stopped.
- Make sure that the seat is completely secured after each adjustment.
- Do not allow any person other than the operator to ride on the tractor.

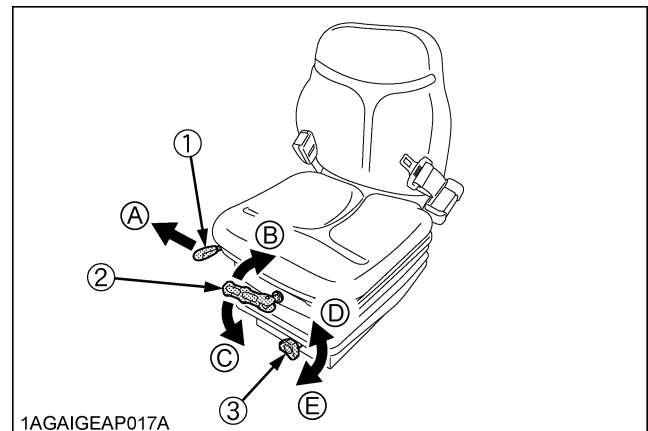

(1) Travel adjust lever

(2) Suspension adjust lever

(3) Height adjust knob

(A) "UNLOCK"

(B) "TO INCREASE TENSION"

(C) "TO DECREASE TENSION"

(D) "HIGH"

(E) "LOW"

◆ Travel adjustment

Unlock the travel adjust lever and slide the seat backward or forward, as required. The seat will lock in position when the lever is released.

◆ Suspension adjustment

Turn the suspension adjust lever to achieve the optimum suspension setting.

◆ **Height adjustment**

Turn the height adjust knob to desired position while sitting in the seat.

IMPORTANT :

- After adjusting the operator's seat, be sure to check to see that the seat is properly locked.

■ **Seat Belt**



WARNING

To avoid personal injury or death:

- Always use the seat belt when any ROPS or CAB are installed.

Adjust the seat belt for proper fit and connect the buckle. This seat belt is auto-locking retractable type.

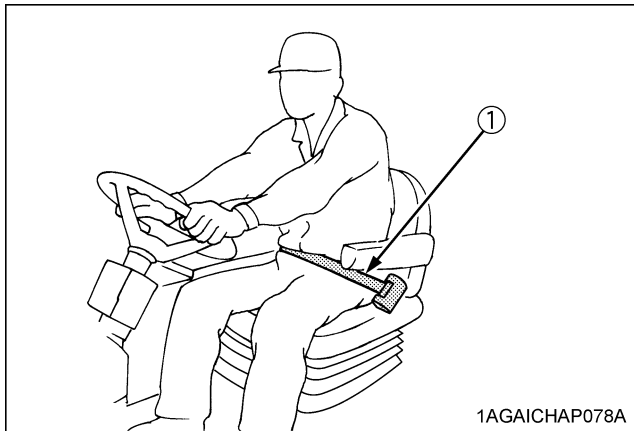

(1) Seat belt

■ **Muffler**

[M5N-091, M5N-111]



WARNING

To avoid personal injury or death:

- Do not touch the muffler pipe or muffler while the engine is running or while muffler pipes are hot.
The high temperature will cause burning.
- Remove all weeds, straw, and combustible material from the muffler pipe, muffler and exhaust manifold to prevent fires.

If necessary, loosen the bolt and adjust the muffler pipe to the proper direction for the work.

Muffler pipe is not directed toward of the front tire or fuel tank.

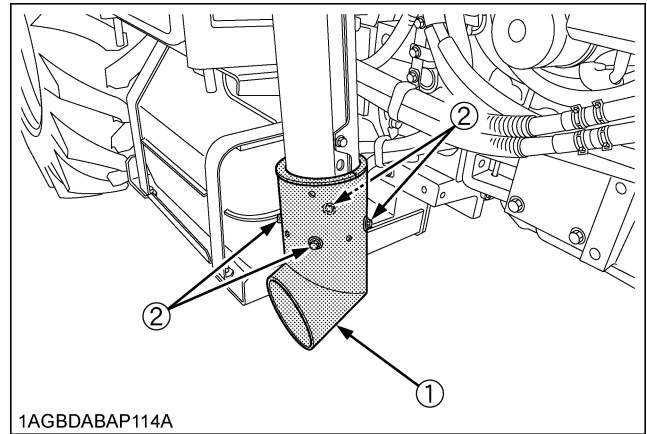

(1) Muffler pipe
(2) Bolt (M6)

■ **Tilt Steering Adjustment**



CAUTION

To avoid personal injury:

- Do not adjust the steering wheel while the tractor is in motion.

Press down the steering wheel tilt pedal, to release the lock so the steering wheel can be adjusted to the best driving positions.

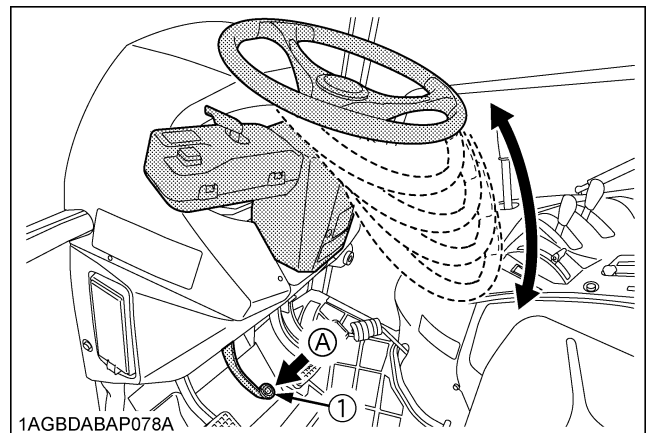

(1) Steering wheel tilt pedal (A) "PRESS DOWN"

2. Selecting Light Switch Position.

■ Light Switch

Turn the light switch clockwise, and the following lights are activated on the switch position.

- Head lights OFF.
- ☉ Head lights dimmed, low beam.
Tail lights ON.
- ☉ Head lights ON, high beam.
Tail light ON

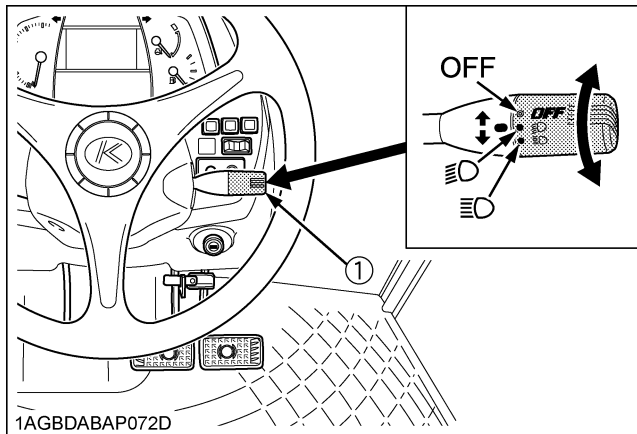

(1) Head light switch

■ Turn Signal / Hazard Light Switch

◆ Hazard Light

1. When the hazard light switch is pushed, the hazard lights flash, along with the L/H and R/H indicators on the instrument panel.
2. Push the hazard light switch again to turn off the hazard lights.

◆ Turn Signal with Hazard Light

1. To indicate a right turn with the hazard lights already flashing, turn the switch clockwise.
2. To indicate a left turn with the hazard lights already flashing, turn the switch counterclockwise.
3. When the left or right turn signal is activated in combination with the hazard lights, the indicated turning light will flash and the other will stay on.

◆ Turn Signal without Hazard Light

1. To indicate a right turn without hazard lights, turn the switch clockwise.
2. To indicate a left turn without hazard lights, turn the switch counterclockwise.
3. When the left or right turn signal is activated without the hazard lights, the indicated turning light will flash and the other will stay on.

NOTE :

- The hazard light switch is operative when the key switch is in either the "ON" or "OFF" position.
- The turn signal light switch is only operative when the key switch is in the "ON" position.
- Be sure to return the turn signal switch to center position after turning.

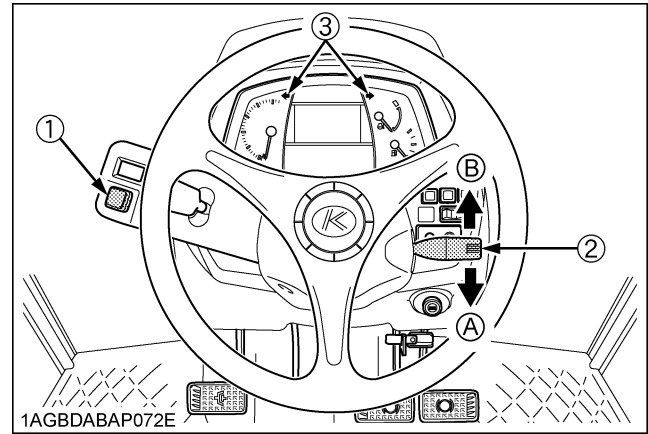

(1) Hazard light switch
(2) Turn signal light switch
(3) Hazard / Turn signal indicator

(A) "RIGHT TURN"
(B) "LEFT TURN"

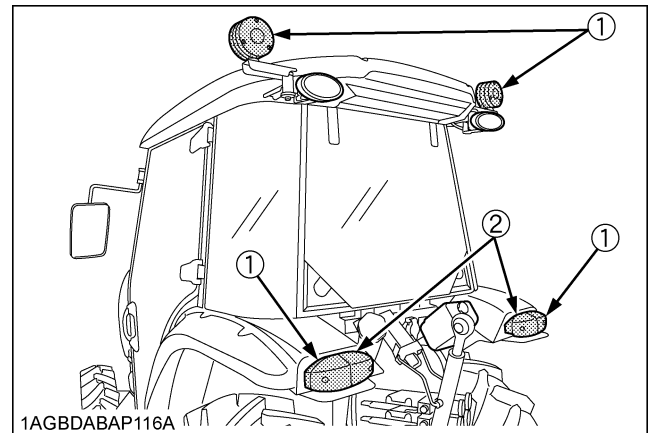

(1) Hazard / Turn signal light
(2) Tail / Turn signal light

■ Rear Turn Signal / Hazard Light

If necessary, raise and turn the light stay to the rearward for the work.

Return the light stay to the original position when traveling on a road.

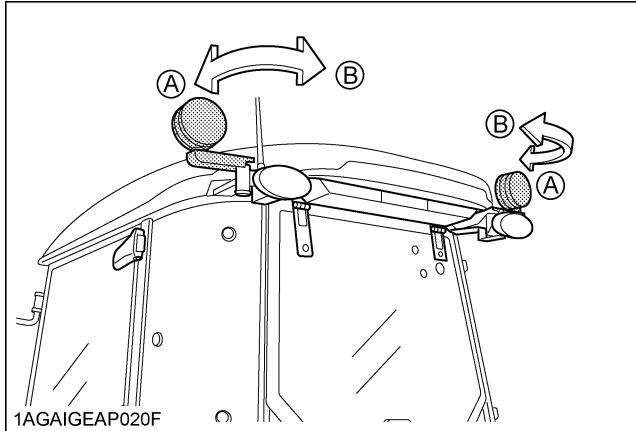

(A) "ORIGINAL POSITION"
(B) "WORK POSITION"

■ Horn Button

The horn will sound when the key switch is "ON" position and horn button is pushed.

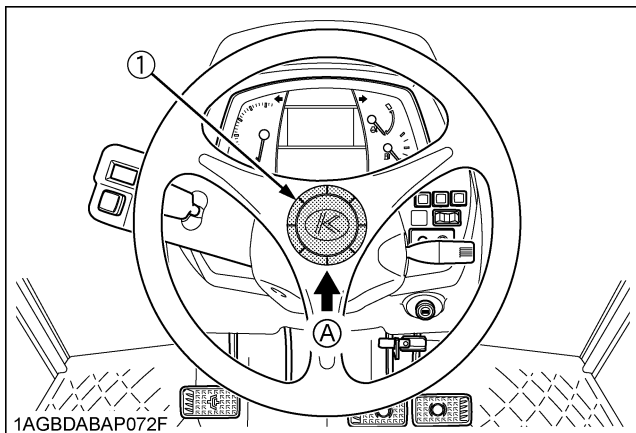

(1) Horn button

(A) "PUSH"

3. Checking the Brake Pedal.

■ Brake Pedals (Right and Left)



WARNING

To avoid personal injury or death:

- Be sure to interlock the right and left pedals. Applying only one rear wheel brake at high speeds could cause the tractor to swerve or roll-over.
- Be sure brake pedals have equal adjustment when using locked together. Incorrect or unequal brake pedal adjustment can cause the tractor to swerve or roll-over.



WARNING

To avoid personal injury or death:

- Be aware of the enhanced braking characteristics of 4 wheel braking system. Appropriate care should be taken during hard braking and/or when pulling towed loads.
- Do not brake suddenly. An accident may occur as a result of a heavy towed load shifting forward or loss of control.
- To avoid skidding and loss of steering control when driving on icy, wet, or loose surfaces, make sure the tractor is correctly ballasted, operated at reduced speed, operated with front wheel drive engaged (If equipped).
- The braking characteristics are different between 2 and 4-wheel drive. Be aware of the difference and use carefully.
- Engage 4-wheel drive for 4-wheel braking when traveling down a slope.

1. Before operating the tractor on the road, be sure to interlock the right and left pedals as illustrated below.
2. Use individual brakes to assist in making sharp turns at slow speeds (Field Operation Only). Disengage the brake pedal lock and depress only one brake pedal.
3. Be sure brake pedals have equal adjustment when being used locked together.

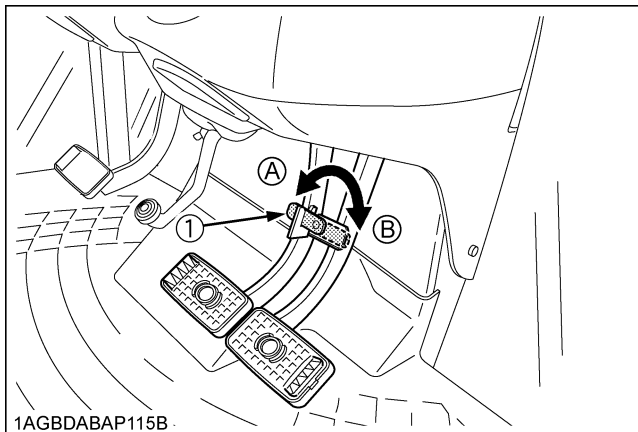

(1) Brake pedal lock

(A) "LOCK"
(B) "RELEASE"

◆ 4WD Braking System [4WD model]

4WD model tractor is equipped with 4WD braking system. When both brake pedals are applied together, the front axle is engaged for 4-wheel braking regardless of the mode selected at the 4WD switch.

When you step on the brake pedal while driving in 2WD mode, the "4WD braking system" gets activated and the 4WD indicator lights up.



WARNING

To avoid the possibility of personal injury, death or property damage from machine runaway during testing, service or repair with the rear wheels off the ground, make sure:

- Battery is disconnected and engine is not started.

If it is necessary to run the engine, make sure:

- Both front and rear wheels are off the ground and secured with stands before starting engine.

4. Raise the Implement. (see "HYDRAULIC UNIT" section.)

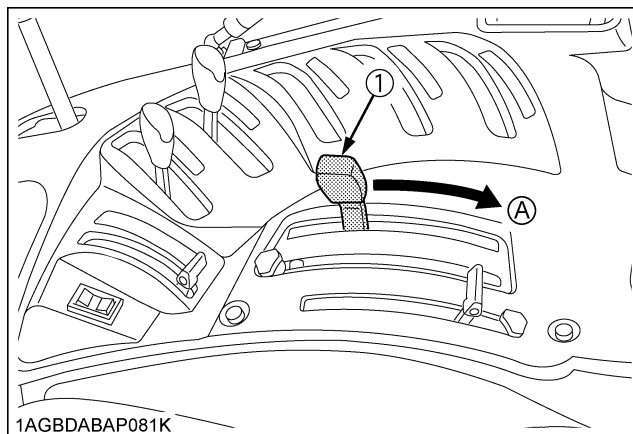

(1) Position control lever (A) "UP"

5. Depress the Brake Pedals and Release the Parking Brake Lever.

■ Parking Brake Lever

To release the parking brake, depress the brake pedal, push the release button and move the lever to transport position.

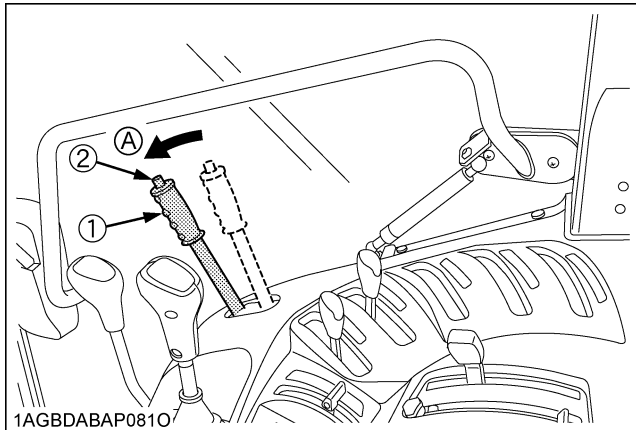

(1) Parking brake lever (A) "TRANSPORT POSITION"
(2) Release button

NOTE :

- The parking brake warning indicator on the Easy Checker(TM) will turn off when the parking brake is unlocked.
- If the shuttle shift lever is moved when the parking brake is applied, an alarm buzzer will sound.

6. Depress the Clutch Pedal.

■ Clutch Pedal



WARNING

To avoid personal injury or death:

- Sudden release of the clutch may cause the tractor to lunge in an unexpected manner.

The clutch is disengaged when the clutch pedal is fully pressed down.

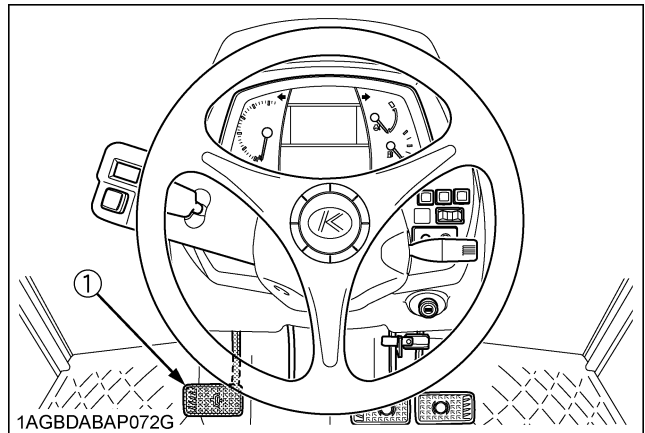

(1) Clutch pedal

IMPORTANT :

To help prevent premature clutch wear:

- The clutch pedal must be quickly disengaged and be slowly engaged.
- Avoid operating the tractor with your foot resting on the clutch pedal.
- Select proper gear and engine speed depending on the type of job.

7. Selecting the Travel Speed.

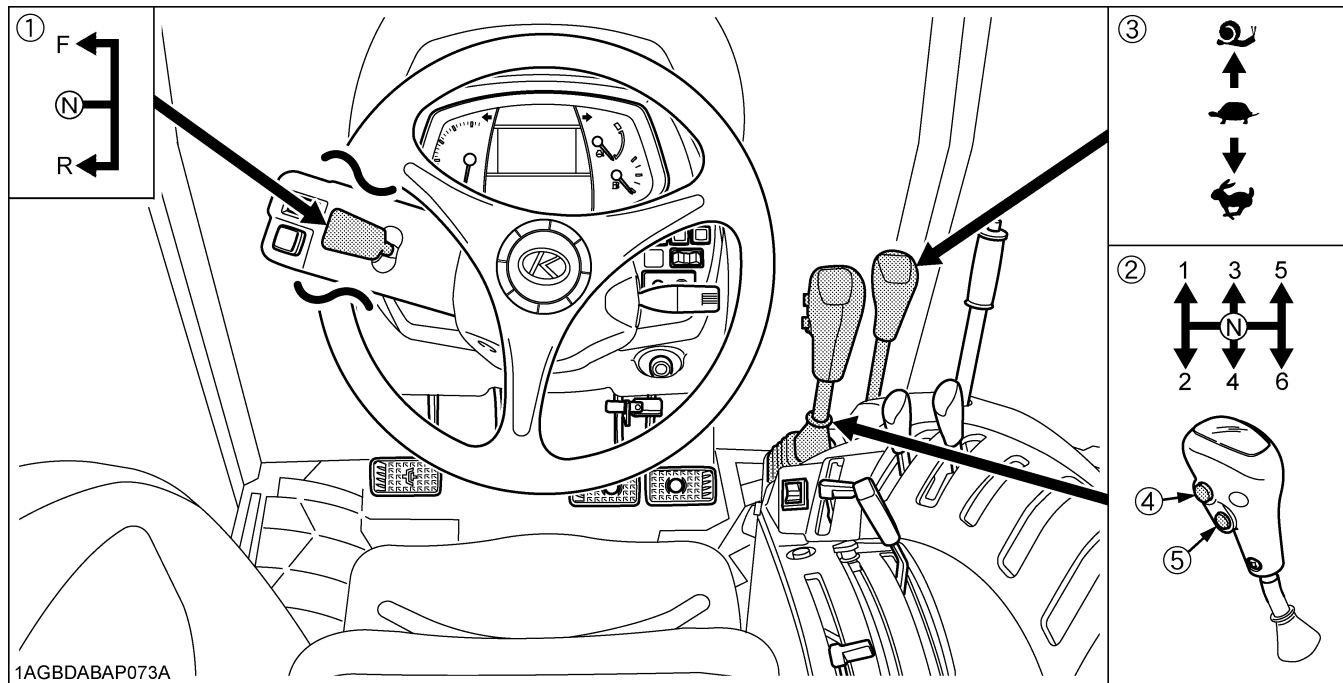

- (1) Shuttle shift lever
- (2) Main gear shift lever
- (3) Range gear shift lever
- (4) Clutch off switch [Dual speed model]
- (5) Dual speed shift switch [Dual speed model]
- (F) "FORWARD"
- (N) "NEUTRAL POSITION"
- (R) "REVERSE"
- "LOW"
- "HIGH"
- "CREEP" (if equipped)

By combination of using the main gear shift lever, dual speed shift switch, range gear shift lever and shuttle shift lever, forward speeds and reverse speeds shown in the table below are obtained.

Standard model (F12 / R12)	Without creep	12 forward speeds 12 reverse speeds
	With creep	18 forward speeds 18 reverse speeds
Dual speed model (F24 / R24)	Without creep	24 forward speeds 24 reverse speeds
	With creep	36 forward speeds 36 reverse speeds

■ Travel Speed Limiter

The highest travel speed is reachable when the engine rpm is at around the middle level with the maximum travel speed range. This provides for a fuel-efficient run while traveling along roads, pulling a trailer, etc. Step on the foot throttle, and the engine rpm rises proportionally and the travel speed goes up accordingly. But the engine speed is limited to 2080 rpm or so, and it does not increase even if the foot throttle is increased.

When the main gear shift lever is set to the H-6 position, the Rev-Limiter indicator illuminates.

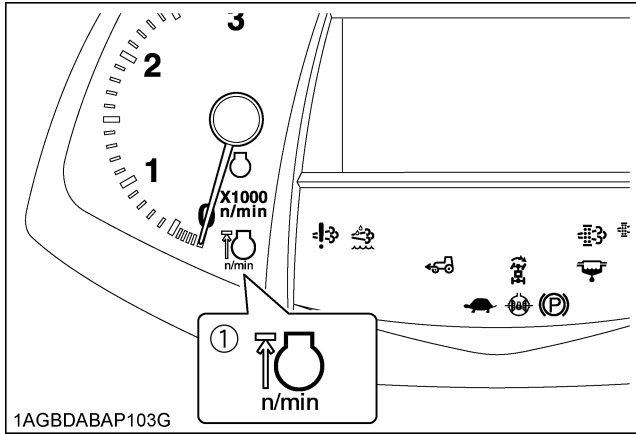

(1) Rev-limiter indicator

■ Main Gear Shift Lever

The main gear shift is fully synchronized to shift without stopping.

IMPORTANT :

- The main gear shift may be shifted between speeds on-the-go, but the clutch must be depressed.

■ Range Gear Shift Lever

The range gear shift can only be shifted when the tractor is completely stopped and the clutch is depressed.

IMPORTANT :

- To avoid transmission damage, depress clutch pedal and stop the tractor before shifting between ranges.

■ Shuttle Shift Lever

⚠ WARNING

To avoid personal injury or death:

- If the shuttle shift lever is moved in forward or reverse position while the parking brake is applied, an alarm buzzer will sound. If the buzzer sounds, return the shuttle shift lever to neutral position.
- If the parking brake lever is released while the buzzer is sounding, the tractor will lunge unexpectedly.

Raise up and shift the shuttle shift lever forward to obtain forward speeds and shift back to obtain reverse speeds. This shifting does not require clutch operation.

IMPORTANT :

- The shuttle shift lever may be shifted while the tractor is moving slowly.

NOTE :

- While the shuttle shift lever is at the "NEUTRAL" position, the "N" character appears on the LCD monitor.

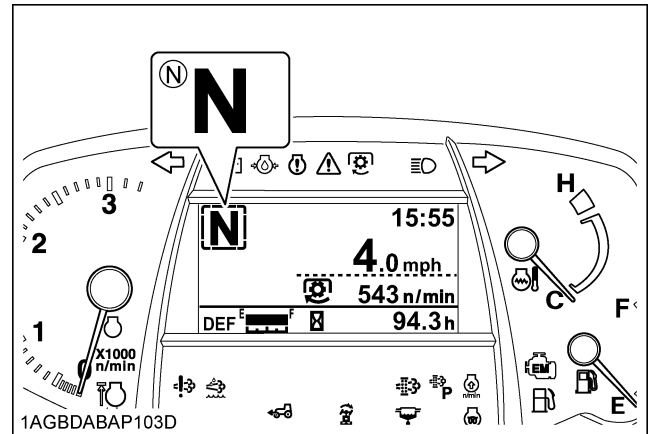

(N) "NEUTRAL"

■ Dual Speed Shift Switch

[Dual speed model]

The dual speed shift switch can be operated when the tractor is traveling without using the clutch.

(This switch effects tractor travel speed change by about 19%). "LO" speed and "HI" speed change at each time this switch is pushed.

◆ Dual Speed Indicator

The indicator comes on when the dual speed switch is set to "LO".

The indicator goes off when the dual speed switch is set to "HI".

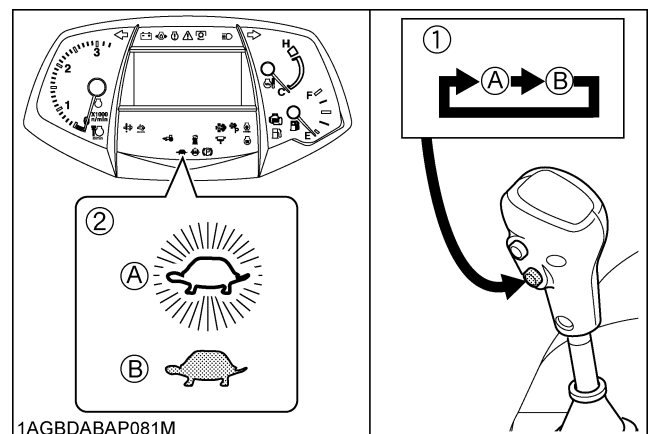

(1) Dual speed shift switch
(2) Dual speed indicator

(A) "LO"
(B) "HI"

■ Clutch Off Switch

[Dual speed model]



WARNING

To avoid personal injury or death:

- If you release the clutch off switch when the travel speed is selected, the clutch becomes engaged and the tractor will begin to move.
- Always use the clutch pedal to start the tractor.

The clutch off switch can be shifted a gear without using the clutch pedal.

While pressing the clutch off switch, the clutch is disengaged.

When releasing the clutch off switch, the clutch is engaged.

(As if to shift the shuttle shift lever from N to F (or R), clutch is engaged by modulate.)

NOTE :

- While pressing the clutch off switch, position display of the shuttle shift lever on the LCD monitor is flashed.

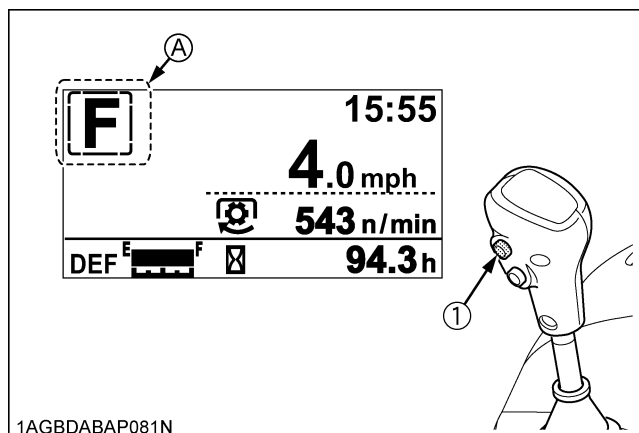

1AGBDABAP081N

(1) Clutch off switch

(A) "FLASH"

■ Creep Speed (if equipped)

Shift the range gear shift lever to to obtain low speeds.

This shifting requires clutch operation.

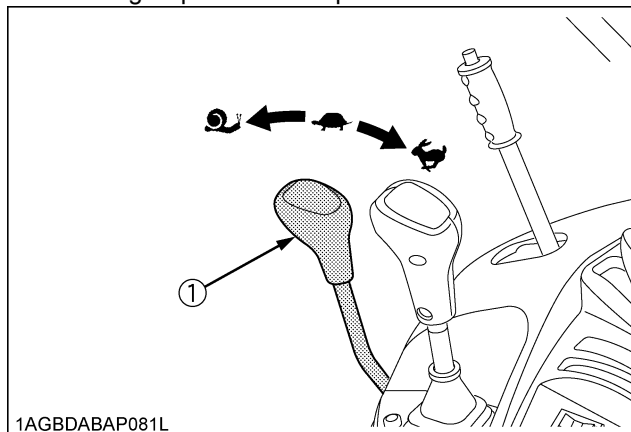

1AGBDABAP081L

(1) Range gear shift lever ...Creep ON

◆ Creep speed should be used only when doing one of the following jobs:

1. Deep rotary-tilling and harrowing
2. Planting
3. Turf application

◆ Creep speed can not be used for any of the followings:

1. Pulling a trailer
2. Front-loader operation
3. Front-blade operation
4. Earth-moving
5. Entering and leaving a field
6. Loading onto and unloading from a truck



WARNING

To avoid personal injury or death:

- When you leave the tractor, be sure to apply the parking brake and stop the engine.
- IN APPLYING THE BRAKES:
 - The torque of the wheel axle is extremely high while creep speed is being used. Be sure to step down on the clutch pedal completely before applying the brakes, or they will not work
 - When starting to operate the tractor, be sure to release the parking brakes. Misuse of the brakes may cause damage to the transmission and is therefore not acceptable to KUBOTA for coverage under the warranty.

IMPORTANT :

- Press the clutch pedal completely down and stop the tractor's motion before shifting the range gear shift lever.

4WD / Bi-speed Turn Switch

WARNING

To avoid personal injury or death:

- Do not engage the front wheel drive when traveling at road speed.
- When driving on icy, wet, or loose surfaces, make sure the tractor is correctly ballasted to avoid skidding and loss of steering control. Operate at reduced speed and engage front wheel drive.
- 4WD model tractor is equipped with 4 wheel braking and appropriate care should be taken during hard braking.
- An accident may occur if the tractor is suddenly braked, such as by heavy towed loads shifting forward or loss of control.
- The braking characteristics are different between 2 and 4 wheel drive tractor models. Be aware of the difference and use carefully.
- Do not use "Bi-speed Turn" at high speed.
- "Bi-speed Turn" enables short and fast turns, therefore, become familiar with its performance before operating in close or confined areas.

Press the right half of this switch;

The front wheel drive (4WD) is engaged.
The 4WD indicator comes on when the system is in 4WD mode.

Press the left half;

The Bi-speed turn system activates.
The 4WD indicator and Bi-speed turn indicator come on when the system is in Bi-speed turn mode.

It returns to a central position;

The drive system returns to 2WD mode
The all indicators goes off when the system is in 2WD mode.

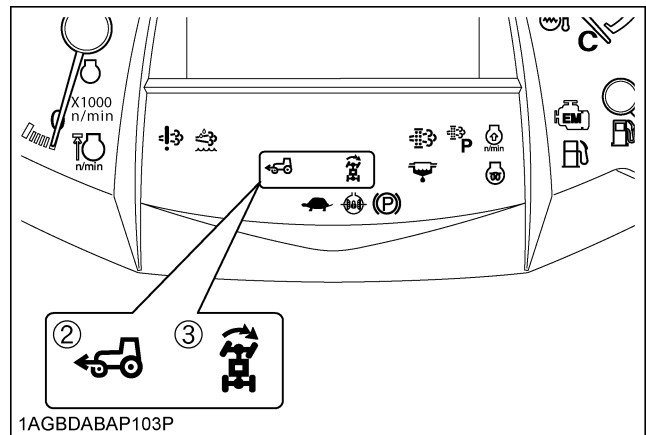
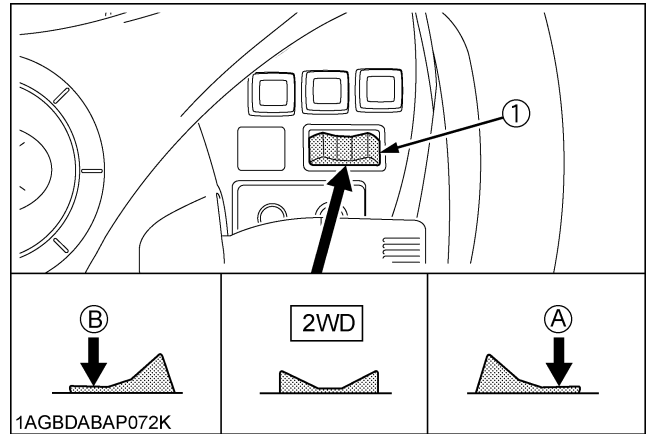

- (1) 4WD/Bi-speed Turn switch
- (A) 4WD "ON"
- (2) 4WD indicator
- (B) Bi-speed turn "ON"
- (3) Bi-speed turn indicator

NOTE :

- This switch can be operated when the tractor is on the go or at rest without depressing the clutch.
- Bi-speed turn system works when you press the "4WD/Bi-speed turn switch" and the front tire (inside of the turn) exceeds 35 degrees.
Bi-speed turn makes the front tire speed 1.6 times faster than the standard 4WD front tire speed.
- "Bi-speed Turn" operates only when the tractor travel speed is 10 km/h (6.2 mph) or less at the start of the turn.

◆ Front wheel drive is effective for the following jobs:

1. When greater pulling force is needed, such as working in a wet field, when pulling a trailer, disking or harrowing.
2. When working in sandy soil.
3. When working on a hard soil where a rotary tiller might push the tractor forward.
4. For increased braking at reduced speed.

◆ **Bi-speed turn use is effective for the following jobs:**

1. Turning at the end of rows. (planting, cultivating, harrowing.)
2. Increasing maneuverability when working in tight spaces.

IMPORTANT :

- Tires will wear quickly if the front wheel drive is engaged on paved roads.

8. Accelerate the Engine.

■ **Hand Throttle Lever**

Pulling the throttle lever back decreases engine speed, and pushing it forward increases engine speed.

■ **Foot Throttle**

Use the foot throttle when traveling on the road. Press down on it for higher speed. The foot throttle is interlocked with the hand throttle lever; when using the foot throttle, keep the hand throttle lever in low idling position.

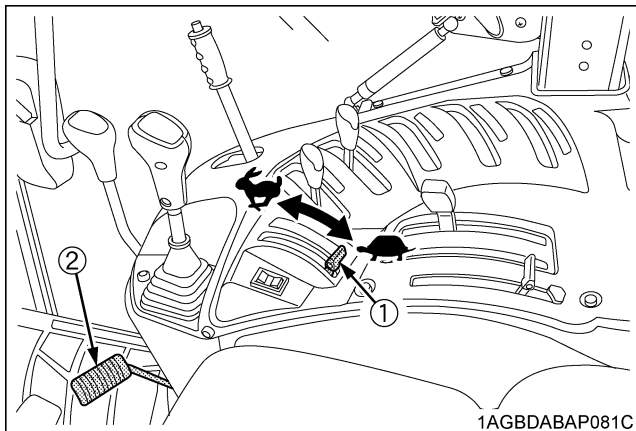

- (1) Hand throttle lever ↖ "INCREASE"
 (2) Foot throttle ↘ "DECREASE"

9. Unlock the Brake Pedals and Slowly Release the Clutch.

STOPPING

■ **Stopping**

1. Slow down the engine.
2. Step on the clutch and brake pedal.
3. After the tractor has stopped, disengage the PTO, lower the implement to the ground, shift the transmission to neutral, release the clutch pedal, and set the parking brake.

CHECK DURING DRIVING

■ **Engine Over-speed Limiting Indicator**

The Engine Overspeed Limiting Indicator informs the operator of engine overspeed by indicator and warning buzzer.

If the warning sounds, immediately lower engine rpm with brakes, etc. When the engine rpm decreases, the warning will stop.

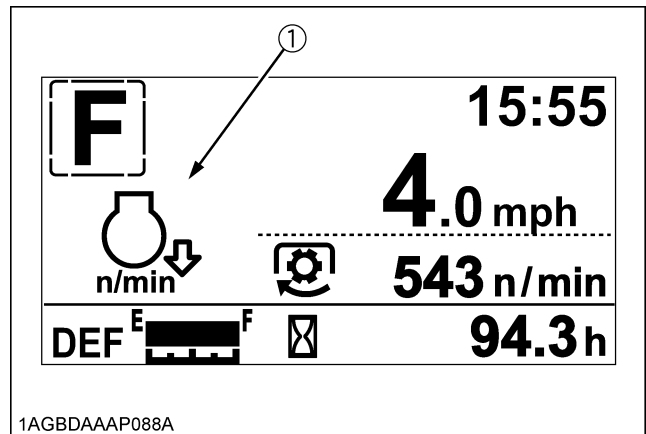

(1) Engine over-speed limiting indicator

NOTE :

- Normal operation will not lead to overspeed, but, for instance, if suddenly shifting down when running with a trailer at full speed, the tractor will be pushed by the trailer and may go into overspeed.

■ **Immediately Stop the Engine if:**

- The engine suddenly slows down or accelerates,
- Unusual noises are suddenly heard,
- Exhaust fumes suddenly become very dark,

■ Easy Checker(TM)

If the warning indicators in the Easy Checker(TM) come on during operation, immediately stop the engine, and find the cause as shown below.

Never operate the tractor while Easy Checker(TM) indicator is on.

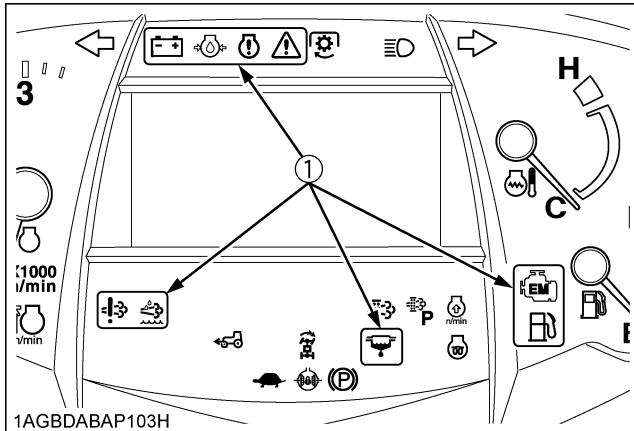

(1) Easy Checker(TM)



Engine warning

This indicator serves the following two functions. If the warning indicator lights up, pinpoint the cause and take a proper measure.

1. Error with the engine control system

If during operation the water temperature gauge reads an acceptable level but the warning indicator in the Easy Checker(TM) comes on, stop the engine and get it restarted. If the error happens again, consult your local KUBOTA Dealer.

IMPORTANT :

- If the warning indicator lights up, the following phenomena may appear depending on the engine's trouble spot.
 - The engine stops unexpectedly.
 - The engine fails to start or gets interrupted just after start.
 - The engine output is not enough.
 - The engine output is enough, but the warning indicator stays on.

If the engine output is not enough, immediately interrupt the operation and move the tractor to a safe place and stop the engine.

2. Engine overheat

If the water temperature gauge reads an unusual level and the warning indicator in the Easy Checker(TM) comes on, the engine may have got overheated. Check the tractor by referring to "TROUBLESHOOTING" section.



Engine oil pressure

If the oil pressure in the engine goes below the prescribed level, the warning indicator in the Easy Checker(TM) will light up.

If this should happen during operation, and it does not go off when the engine is accelerated to more than 1000 rpm, check level of engine oil.

(See "Checking Engine Oil Level" in "DAILY CHECK" in "PERIODIC SERVICE" section.)



DEF/AdBlue® system warning

If trouble should occur at the DEF/AdBlue® system, the warning indicator in the Easy Checker(TM) will light up.

If this should happen during operation, check the DEF/AdBlue® system or consult your local KUBOTA Dealer.



Fuel level

If the fuel in the tank goes below the prescribed level, the indicator in the Easy Checker(TM) will come on. (less than 17 L (4.9 gals.))

If this should happen during operation, refuel as soon as possible.

(See "Checking and Refueling" in "DAILY CHECK" in "PERIODIC SERVICE" section.)

IMPORTANT :

- When the fuel indicator lights up, refuel the tank as soon as possible. If the tractor runs out of fuel and stalls, the engine and its components may be damaged.



Water separator

If water or impurities collect in the water separator, the indicator in the Easy Checker(TM) will light up.

If this should happen during operation, drain the water from the water separator as soon as possible.

(See "Checking Water Separator" in "DAILY CHECK" in "PERIODIC SERVICE" section.)



DEF/AdBlue® level

If the DEF/AdBlue® in the tank goes below the prescribed level, or if a poor-quality product is added, the indicator in the Easy Checker(TM) will light up.

If this should happen during operation, refill or replace with DEF/AdBlue® as soon as possible.

(See "Selective Catalytic Reduction (SCR) MUFFLER" in "OPERATING THE ENGINE" section.)



Emission indicator

If this indicator lights up, take the steps to lower the water temperature. This helps keep the emission clean.



Electrical charge

If the alternator is not charging the battery, the warning indicator in the Easy Checker(TM) will light up.

If this should happen during operation, check the electrical charging system or consult your local KUBOTA Dealer.



Master system warning

If trouble should occur at the engine, transmission or other control parts, the indicator flashes as a warning.

If the trouble is not corrected by restarting the tractor, consult your local KUBOTA Dealer.

NOTE :

- For checking and servicing of your tractor, consult your local KUBOTA Dealer for instructions
- The DEF/AdBlue® system warning indicator and the DEF/AdBlue® level indicator correspond only to the M5N-091 and M5N-111 tractor models.

Fuel Gauge

When the key switch is on, the fuel gauge indicates the fuel level.

Be careful not to empty the fuel tank. Otherwise air may enter the fuel system.

Should this happen, the system should be bled (See "Bleeding Fuel System" in "SERVICE AS REQUIRED" in "PERIODIC SERVICE" section.)

If the engine stall in out of fuel, master system warning indicator lights up. When the indicator appears, turn the key switch to OFF and then to ON again in order to turn off the indicator.

If the indicator does not turn off by restarting the tractor, consult your local KUBOTA Dealer.

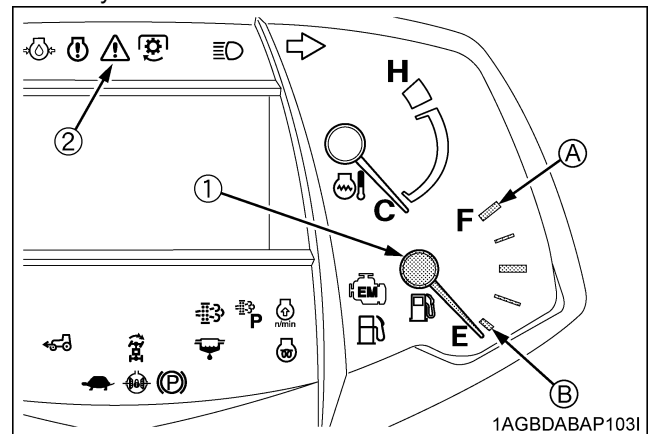

- (1) Fuel gauge
- (2) Master system warning indicator

- (A) "FULL"
- (B) "EMPTY"

1AGBDABAP103I

■ DEF / AdBlue® Gauge

[M5N-091, M5N-111]

The DEF/AdBlue® level in the DEF/AdBlue® tank is indicated with LCD blocks.

If DEF/AdBlue® level drops too low, the engine output is restricted. With this in mind, be careful not to empty the tank.

When the fluid level in the tank has dropped below 15%, the DEF/AdBlue® warning indicator on the instrument panel lights up and stays on.

Immediately add DEF/AdBlue® to the specified level.

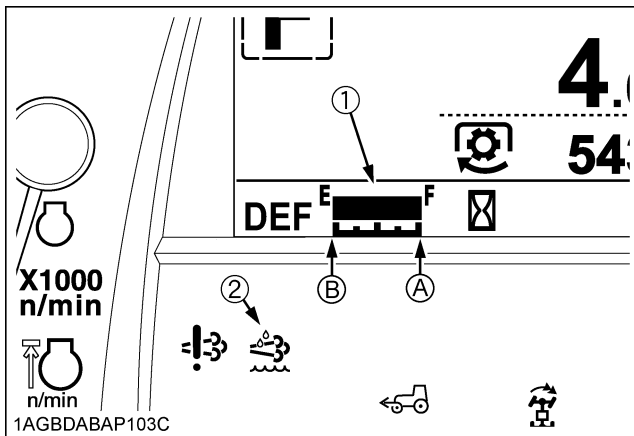

(1) DEF/AdBlue® gauge
(2) DEF/AdBlue® warning indicator

(A) "FULL"
(B) "EMPTY"

■ Coolant Temperature Gauge

⚠ WARNING

To avoid personal injury or death:

- Do not remove radiator cap until coolant temperature is well below its boiling point. Then loosen cap slightly to the stop to relieve any pressure before removing cap completely.

1. With the key switch at "ON", this gauge indicates the temperature of the coolant. "C" for "cold" and "H" for "hot."
2. If the indicator reaches the red zone position, engine coolant is overheated. Check the tractor by referring to "TROUBLESHOOTING" section.

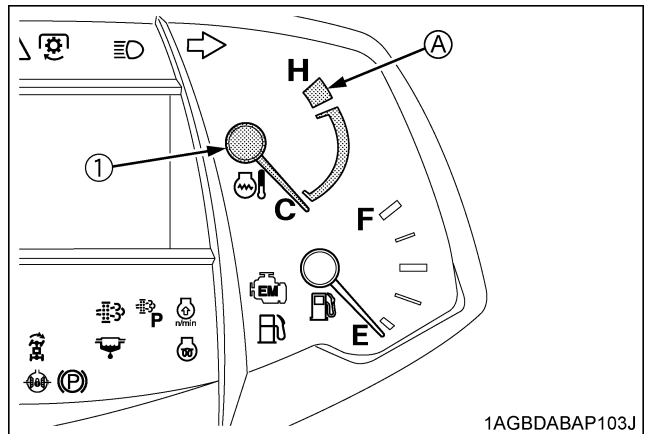

(1) Coolant temperature gauge

(A) "RED ZONE"

■ Tachometer

The tachometer indicates the engine speed on the dial.

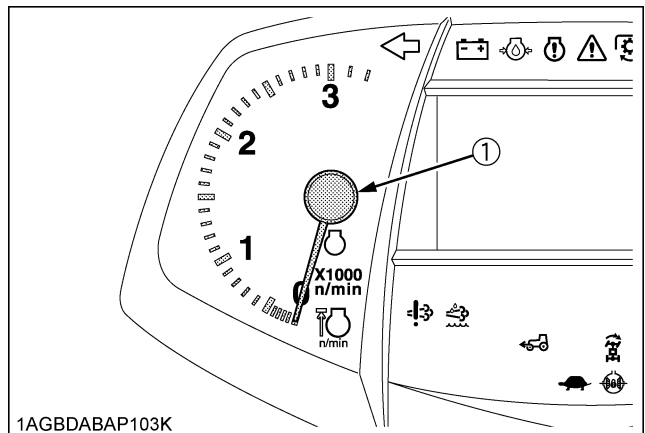

(1) Engine revolution

LCD MONITOR

This display provides the operator with a variety of information necessary to operate the tractor. Further, part of the display can be modified by the operator as required.

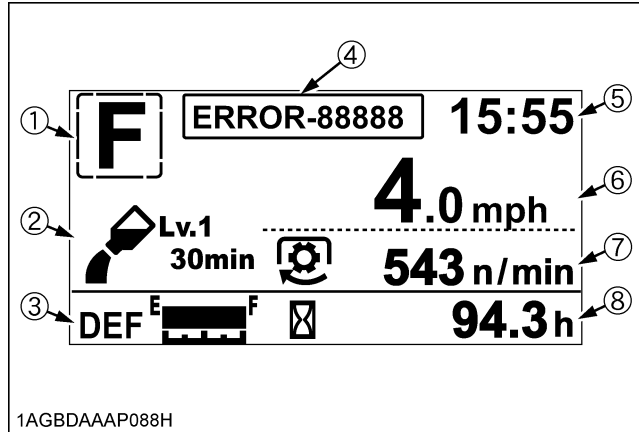

1AGBDAAAP088H

No.	Description	Ref. page	
(1)		Forward operation is selected with the shuttle lever.	---
		Reverse operation is selected with the shuttle lever.	---
		The shuttle lever is at neutral position.	---
		The parking brake lever is at parking position.	---
		The parking brake is applied and F or R is selected with the shuttle lever .	---
	Blinking	Clutch off switch is pushed. (Clutch is disengaged) [Dual speed model]	---
	No display	Shuttle lever system trouble.	---

No.	Description	Ref. page	
(2)		DEF/AdBlue® low level icon indicator [M5N-091, M5N-111]	22
		DEF/AdBlue® poor quality icon indicator [M5N-091, M5N-111]	
		DEF/AdBlue® freeze icon indicator [M5N-091, M5N-111]	
		SCR system trouble [M5N-091, M5N-111]	31
		Low temperature regulation indicator	
		Engine over-speed limiting indicator	
(3)	AdBlue® (DEF) gauge [M5N-091, M5N-111] Displays the fluid level in the DEF/AdBlue®	22	
(4)	Trouble display A trouble-spot-pinpointing error code is displayed.	137	
(5)	Clock	49	
(6)	Travel speed	49	
(7)	PTO speed	49	
(8)	Performance monitor Various information can be selected by the operator.	52	

NOTE :

- Errors may occur in the fuel consumption display depending on the conditions of use. Use the displayed data only as an approximate guide. In particular, do not use the total fuel consumption display mode in place of the fuel gauge.
- The travel speed displayed when the wheels slip under traction is different from the actual one.
- In cold weather the LCD monitor response will normally be slower and the visibility be less, than in warmer weather.

■ Various Setting Mode

While pressing the mode selector switch, turn the key switch to ON position.

Various setting mode screen appears in LCD monitor.

The various setting mode can set 5 items.

Turn the key switch to OFF position, setting is finished.

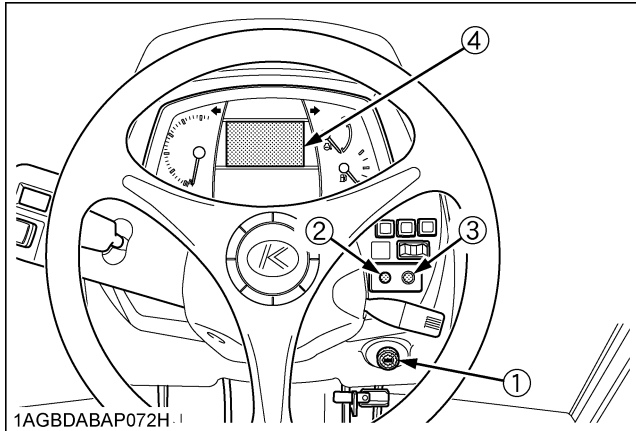

- (1) Key switch
- (2) Mode selector switch
- (3) Select switch
- (4) LCD monitor

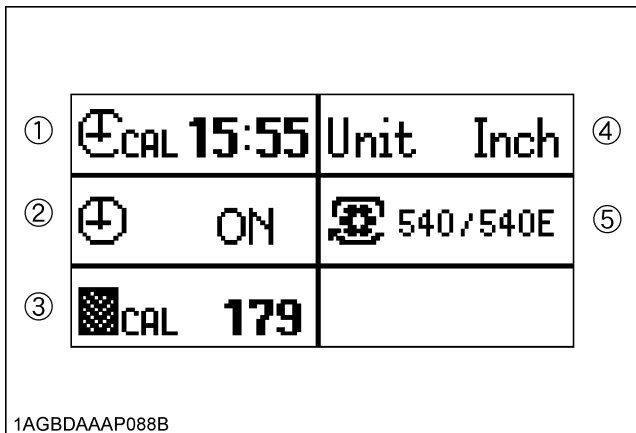

- (1) Clock setting
- (2) Clock ON/OFF setting
- (3) Tire circumference setting
- (4) Unit setting
- (5) PTO speed display setting

◆ Clock setting

1. Press the mode selector switch to choose "Clock setting".
Then press the "Select" switch, and the clock setting screen appears.

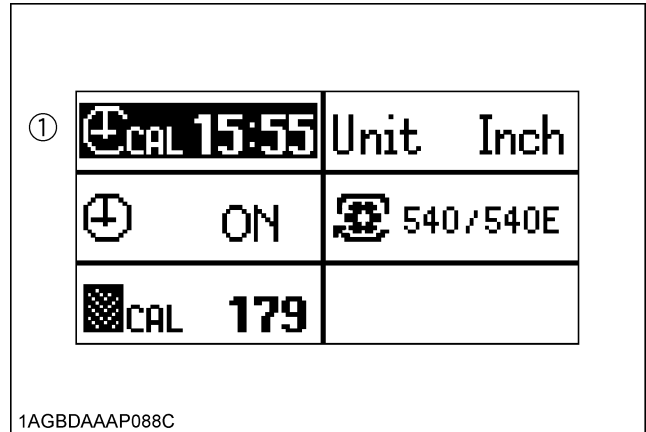

(1) Clock setting

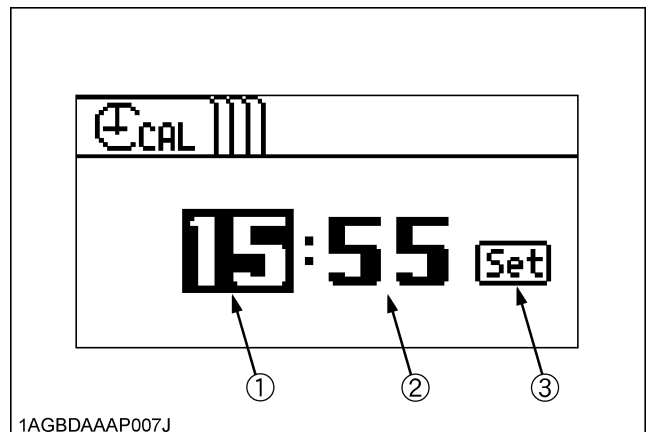

- (1) Hour
- (2) Minute
- (3) Set switch

2. Setting the "Hour" of the clock:
 - (1) Press the mode selector switch to choose the "Hour" (highlighted).
 - (2) To put the clock forward, press the "Select" switch.
3. Setting the "Minute" of the clock:
 - (1) Press the mode selector switch to choose the "Minute" (highlighted).
 - (2) Carry out the "Minute" setting in the same way as the "Hour" setting.
4. Press the mode selector switch.
5. To complete the setting, select "Set" with the "Select" switch.
The various setting mode screen appears again.

◆ **Setting the clock display ON/OFF**

1. Press the mode selector switch to choose "Clock ON/OFF setting".
Then press the "Select" switch, and the clock ON/OFF setting screen appears.

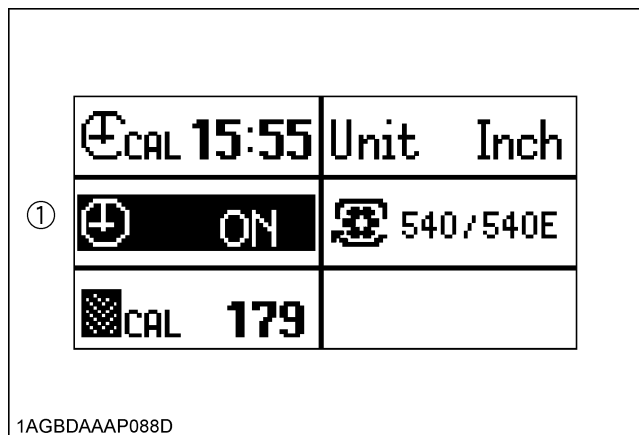

(1) Clock ON/OFF setting

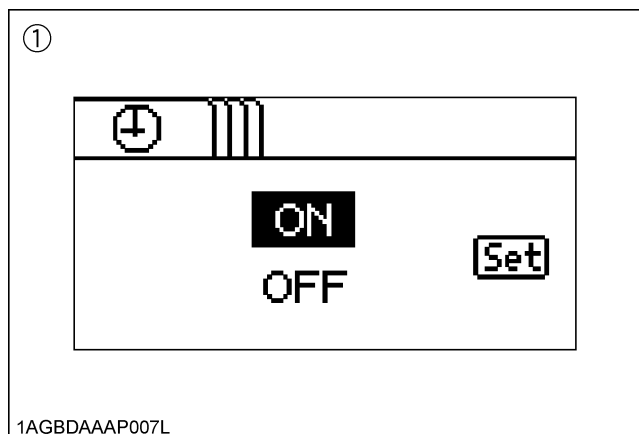

(1) Clock ON/OFF setting screen

2. Press the "Select" switch and select "ON" or "OFF".
3. Press the mode selector switch.
4. To complete the setting, select "Set" with the "Select" switch.
The various setting mode screen appears again.

◆ **Setting the tire circumference**

When optional different-diameter tires are fitted on the machine, the travel speed display mode must be changed. Otherwise the travel speed will not get correctly displayed. Such mode switching is also needed when the original tires are back on the machine.

1. Press the mode selector switch to choose "Tire circumference".
Then press the "Select" switch, and the tire circumference setting screen appears.

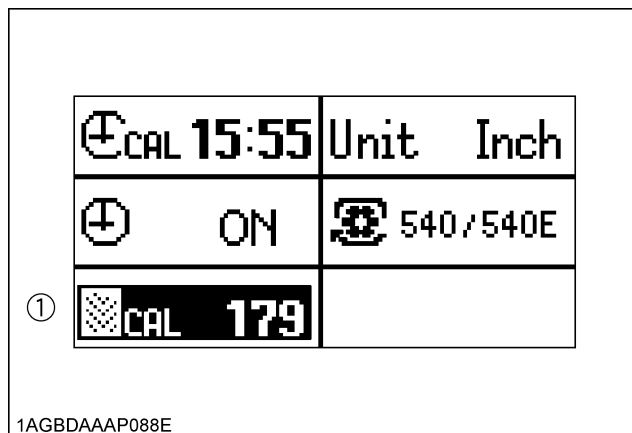

(1) Tire circumference



(1) Tire circumference screen

2. According to the following table, enter the tire circumference value.

- (1) Press the mode selector switch to select a digit.
- (2) To put the number forward, press the "Select" switch. (The numeral changes from 0 to 9 at each push of the switch.)

Tire circumference table (reference)

Rear tire size	Entry (in.)	Entry (cm)
12.4-24 R1	136	345
380/85 R24	146	371
18.4-16.1 R1	133	338
320/85 R20	123	312
480/65 R24	148	376

- 3. Press the mode selector switch.
- 4. To complete the setting, select "Set" with the "Select" switch.
The various setting mode screen appears again.

◆ **Setting the unit**

- 1. Press the mode selector switch to choose "Unit setting". Then press the "Select" switch, and the unit setting screen appears.

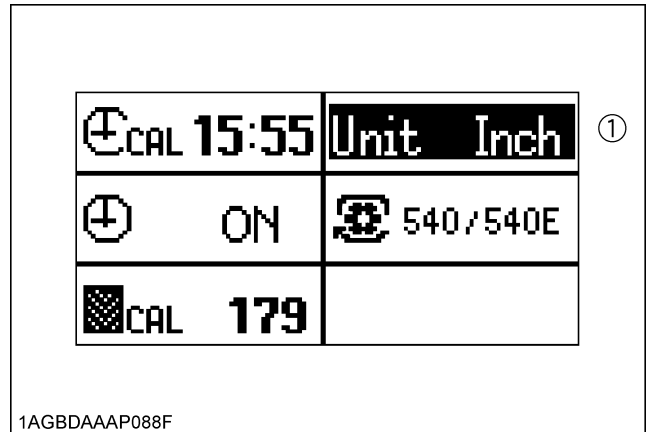

(1) Unit setting

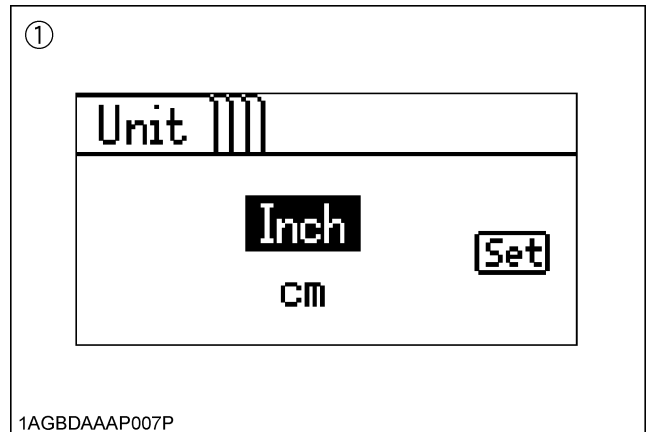

(1) Unit setting screen

- 2. Press the "Select" switch and select "Inch" or "cm".
- 3. Press the mode selector switch.
- 4. To complete the setting, select "Set" with the "Select" switch.
The various setting mode screen appears again.

◆ **Setting the PTO speed display**

The PTO rpm is set automatically and does not require adjusting.

■ Performance Monitor

◆ Display change

Use the mode selector switch and "Select" switch to choose one of the items shown in the table below to be displayed on screen.

◆ Priority display

- When the RPM dual memory setting is "ON", the engine rpm A/B is displayed on the screen. When selecting any other information such as "Hour meter" or "PM buildup", the item will be displayed for approx. 5 seconds before resuming the engine rpm A/B display.
- Turn "OFF" the RPM dual memory setting to display any other information continuously.
(See "RPM Dual Memory Setting" in "ELECTRONIC ENGINE CONTROL" in "OPERATING THE TRACTOR" section.)

◆ List of types of information displayed on the performance monitor

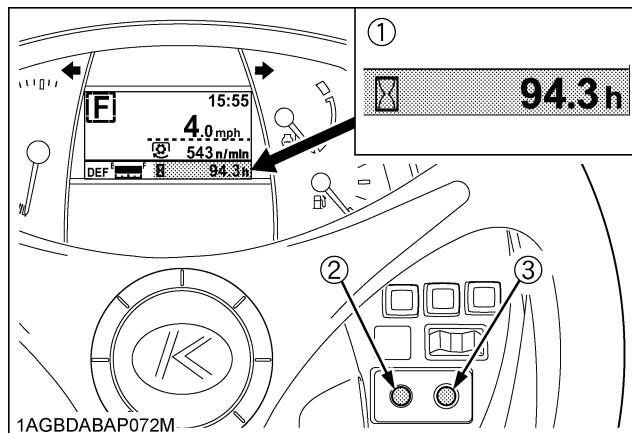

- (1) Performance monitor
(2) Mode selector switch
(3) Select switch

Selected screen (mode)	Display	Remarks		Reference page
1/4		Elapsed time (Hour meter)	<ul style="list-style-type: none"> The hour meter indicates in 6 digits the hours the tractor has been used; the last digit indicates 1/10 of an hour. 	---
		Trip meter	<ul style="list-style-type: none"> The total operating hours, counted from the previous resetting, is displayed. 	---
2/4		Instantaneous fuel consumption	<ul style="list-style-type: none"> The "Instantaneous fuel consumption" is measured per hour. 	---
		Average fuel consumption	<ul style="list-style-type: none"> The "Average fuel consumption" is measured per hour from the previous resetting. 	---
		Total fuel consumption	<ul style="list-style-type: none"> Displays the total fuel consumption measured from the previous resetting. 	---
3/4		PM buildup (percentage)	<ul style="list-style-type: none"> Displays the PM buildup inside the DPF muffler. Regeneration is needed when the 100% level has been reached. 	---
		PM buildup (graph)	<ul style="list-style-type: none"> The more the bar is extended to the right, the more PM builds up. 	
4/4		Memory A rpm	<ul style="list-style-type: none"> Engine RPM dual memory A rpm is displayed. 	53
		Memory B rpm	<ul style="list-style-type: none"> Engine RPM dual memory B rpm is displayed. 	53

NOTE :

- Hold down the mode selector switch for 2 seconds or longer to reset the "Trip meter", "Average fuel consumption" and "Total fuel consumption" displays to [0.0]

ELECTRONIC ENGINE CONTROL

The electronically controlled engine which is installed in this tractor performs the following 2 types of control.

1. RPM dual memory setting
2. Constant RPM management control

■ RPM Dual Memory Setting

Two different engine speeds can each be set with a single touch by pressing the RPM dual memory switch to the (A) or (B) side. This can be used to eliminate troublesome acceleration operations.

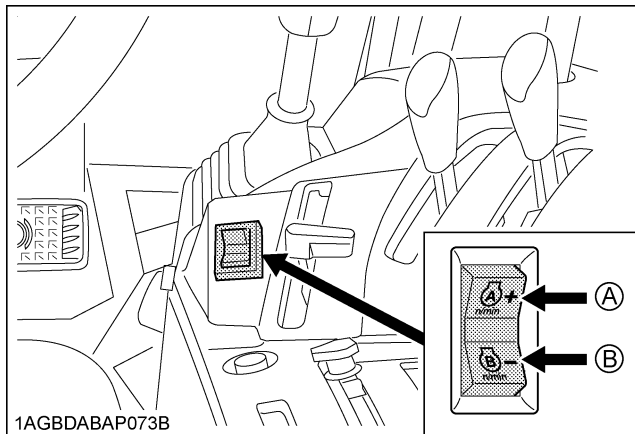

(1) RPM dual memory switch (A) Switch A (B) Switch B

◆ Example of use

Consider an example in which an engine speed of 2000 rpm is set for the switch (A) side and a speed of 1000 rpm is set for the switch (B) side.

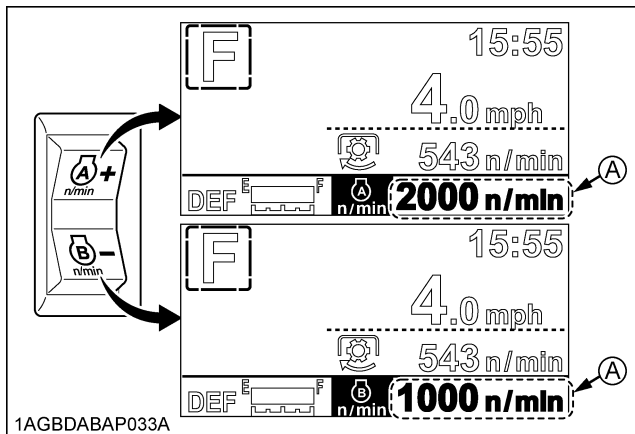

(A) Light up... Engine revolution is operating in the rpm memory setting value.
Flashing... Engine revolution is less than the rpm memory setting value.

Work ↓	 1AGBDABAP033B	During work, simply press the switch to the (A) side to automatically set an engine speed of 2000 rpm.
Turning ↓	 1AGBDABAP033C	When turning, press the switch to the (B) side to lower the speed to 1000 rpm, allowing turning at low speed.
Work	 1AGBDABAP033B	After turning, press the switch again to the (A) side to resume a speed of 2000 rpm.

- Keep the hand throttle lever above the minimum speed. At the minimum speed, a memory setup can not be performed.
- You can also depress the foot throttle to increase the engine speed above the set speed.

◆ Setting the speeds (or changing the speed settings)



Setting RPM dual memory switch (A)

1. Turn the key switch to "ON". (The speed setting can be made both when the engine is running or stopped.)

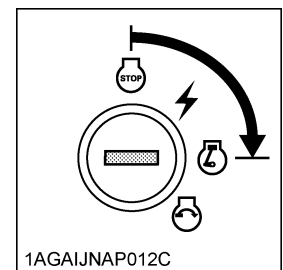

2. Set the hand throttle lever slightly toward the higher-speed side.

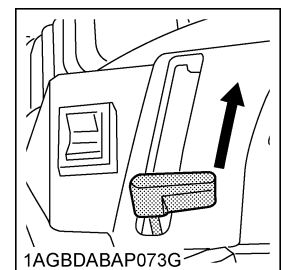

- Press the switch (A) side and then release the switch.

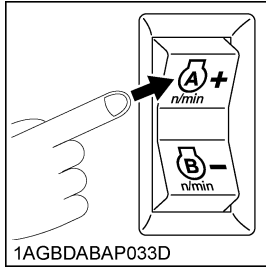

- Again press and hold down the switch (A) side (2.5 seconds) until the buzzer sounds, then release the switch.

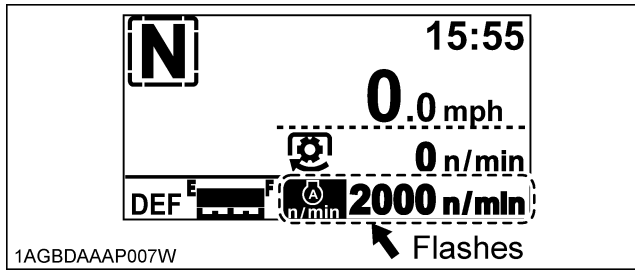
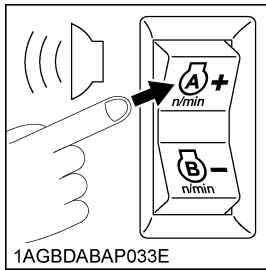

- Press the switch to the (A) or (B) side and set the speed.
Pressing and holding down the switch will cause the speed to change continuously. Pressing and releasing the switch changes the speed by 10 rpm each time. Set the desired engine speed while watching the speed display.

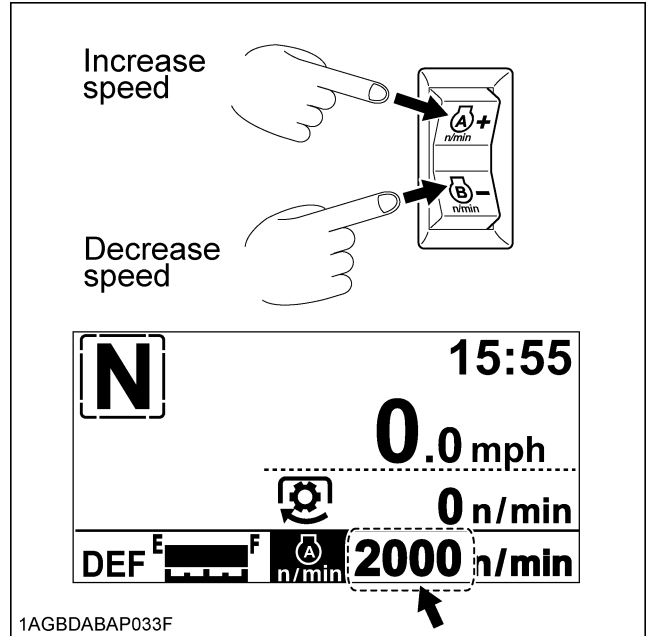

- If the switch is released and not operated for 4 seconds, a continuous buzzer sound occurs and the setting is completed.
- Follow the same procedure as for the (A) side to set the speed for the switch (B) side.

NOTE :

- The set speeds will be stored even after the engine is stopped.

◆ Canceling the setting

Any of the actions below will cancel the RPM dual memory settings.

- [Switch (A) side]**
When the memory speed is engaged, press the switch (A) again to cancel.
[Switch (B) side]
When the memory speed is engaged, press the switch (B) again to cancel.
When the memory speed is canceled, the speed will return to the speed that is determined by the hand throttle lever (foot throttle).
(When the switch is pressed, the LCD will display the engine speed that is in effect after memory speed is canceled.)
- Return the hand throttle lever to the lowest speed position.
- Turn the key switch to "OFF".

■ Constant RPM Management Control

Constant RPM Management can be turned "ON" or "OFF" by operating the switch. Pressing the switch turns the control "ON" and pressing the switch again turns it "OFF".

◆ When constant RPM management is "ON"

Fluctuations in the engine speed due to load fluctuations are reduced and the travel speed and PTO speed are kept nearly constant, allowing stable work. When constant RPM management is "ON", the switch's indicator light up.

◆ When constant RPM management is "OFF"

As in a conventional engine, the engine speed increases or decreases according to changes in the load. The operator judges the size of the load from the engine speed and engine sound, and can adjust the travel speed or plowing depth to prevent overload on the tractor.

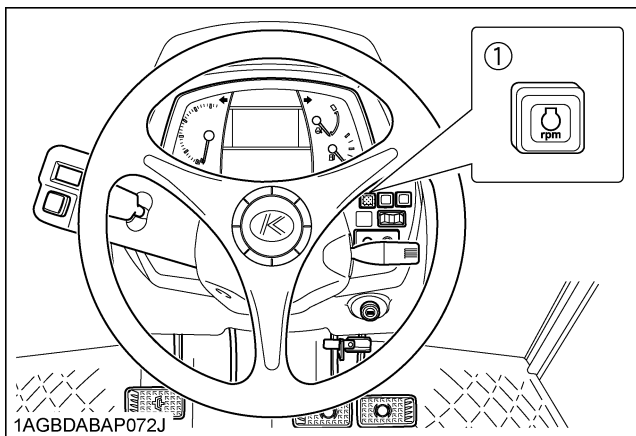

(1) Constant RPM management switch with indicator

NOTE :

- In a mechanically-controlled engine, the engine speed changes according to increases and decreases in the load.

For example, when working in a hilly area, the load increases and engine speed drops while ascending a slope, and conversely the load drops when descending. These changes in engine speed affect the travel speed and PTO-driven implements. In order to minimize these effects, the operator must make fine adjustments to the travel speed and hand throttle lever.

When the constant RPM management switch in this tractor with its electronically controlled engine is turned "ON", the engine speed will be kept nearly constant in response to a certain level of load fluctuations. This improves the accuracy of work without the need for troublesome manipulation of the travel speed and hand throttle lever.

- There is a limit to the range within which a constant speed can be maintained. If a load exceeding the engine performance is applied, the engine speed will drop.

- The purpose of constant RPM management is not to increase the engine power.

PARKING

■ Parking



WARNING

To avoid personal injury or death:
BEFORE DISMOUNTING TRACTOR

- ALWAYS SET PARKING BRAKE AND LOWER ALL IMPLEMENTS TO THE GROUND.
Leaving transmission in gear with the engine stopped will not prevent the tractor from accidental rolling.
 - STOP THE ENGINE AND REMOVE THE KEY.
1. Before getting off the tractor, disengage the PTO, lower all implements, place all control levers in their neutral positions, pull the parking brake lever to parking position, stop the engine and remove the key.
 2. If it is necessary to park on an incline, be sure to chock the wheels to prevent accidental rolling of the machine.

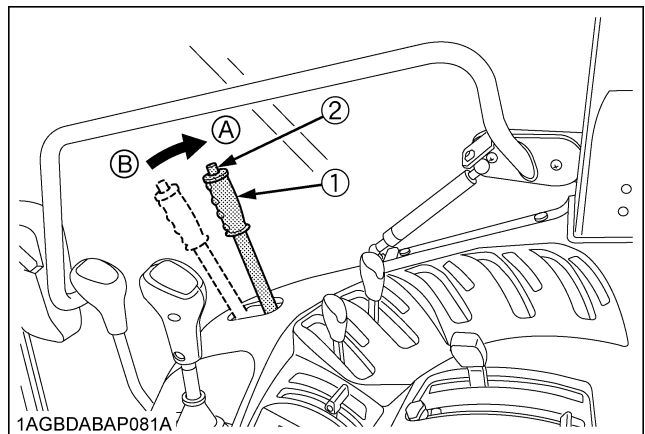

(1) Parking brake lever
(2) Release button

(A) "PARKING POSITION"
(B) "TRANSPORT POSITION"

OPERATING TECHNIQUES

■ Differential Lock



WARNING

To avoid personal injury or death due to loss of steering control:

- Do not operate the tractor at high speed with differential lock engaged.
- Do not attempt to turn with the differential lock engaged.
- Be sure to release the differential lock before making a turn in field conditions.

If one of the rear wheels should slip, step on the differential lock pedal. Both wheels will turn together, then reduce slippage.

Differential lock is maintained only while the pedal is depressed.

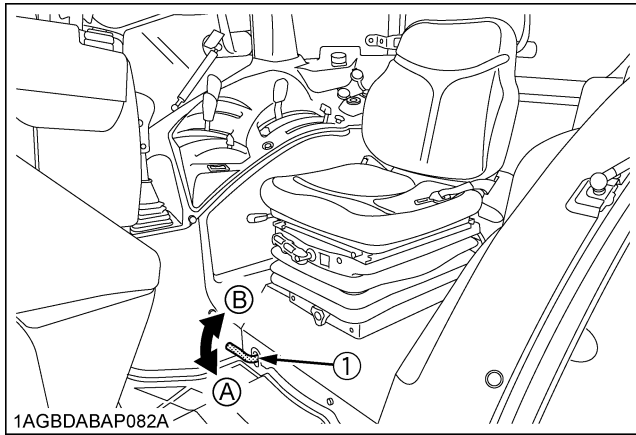

(1) Differential lock pedal (A) Press to "ENGAGE"
(B) Release to "DISENGAGE"

IMPORTANT :

- When using the differential lock, always slow the engine down.
- To prevent damage to power train, do not engage differential lock when one wheel is spinning and the other is completely stopped.
- If the differential lock cannot be released, step lightly on the brake pedals alternately.

■ Operating the Tractor on a Road



WARNING

To avoid personal injury or death:

- To help assure straight line stops when driving at transport speeds, lock the brake pedals together. Uneven braking at road speeds could cause the tractor to roll-over.
- When traveling on road with 3-point hitch mounted implement attached, be sure to have sufficient front weight on the tractor to maintain steering ability.
- When traveling on road with trailer, you must comply with local regulation at all time. The maximum traveling speed with trailer is provided by each country and regulated speed may be different depend on the size of trailer and type of trailer brake system.

Be sure SMV emblem and warning lamps are clean and visible. If towed or rear-mounted equipment obstructs these safety devices, install SMV emblem and warning lamps on equipment.

Consult your local KUBOTA Dealer for further details.

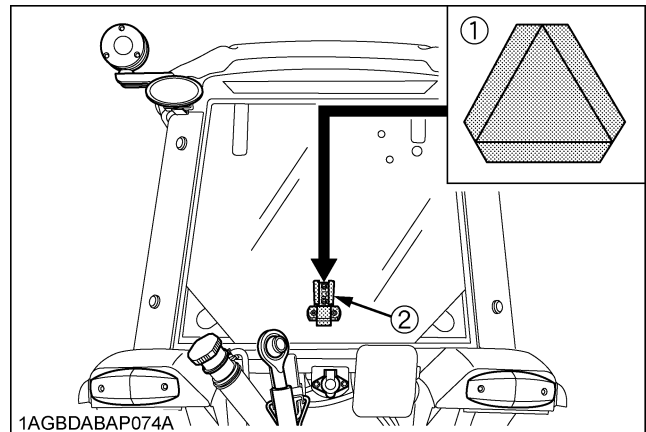

(1) SMV emblem
(2) Bracket

Operating on Slopes and Rough Terrain

WARNING

To avoid personal injury or death:

- Always back up when going up a steep slope. Driving forward could cause the tractor to tip over backward. Stay off hills and slopes too steep for safe operation.
- Avoid changing gears when climbing or descending a slope.
- If operating on a slope, never disengage the clutch or shift levers to neutral. Doing so could cause loss of control.
- Do not drive the tractor close to the edges of ditches or banks which may collapse under the weight of the tractor. Especially when the ground is loose or wet.

1. Be sure wheel tread is adjusted to provide maximum stability.
(See "WHEEL ADJUSTMENT" in "TIRES, WHEELS AND BALLAST" section.)
2. Slow down for slopes, rough ground, and sharp turns, especially when transporting heavy, rear mounted equipment.
3. Before descending a slope, shift to a gear low enough to control speed without using brakes.

Transport the Tractor Safely

1. The tractor, if damaged, must be carried on a truck. Secure the tractor tightly with ropes.
2. Follow the instruction below when towing the tractor: Otherwise, the tractor's powertrain may get damaged.
 - Set the all shift levers to "NEUTRAL" position.
 - If possible, start engine and select 2WD, if creep speed is fitted ensure that it is disengaged.
 - Tow the tractor using its front hitch or drawbar.
 - Never tow faster than "10 km/h (6.2 mph)".

Directions for Use of Power Steering

1. Power steering is activated only while the engine is running. Slow engine speeds make the steering a little heavier. While the engine is stopped, the tractor functions in the same manner as tractors without power steering.
2. When the steering wheel is turned all the way to the stop, the relief valve is activated. Do not hold the steering wheel in this position for a long period of time.
3. Avoid turning the steering wheel while the tractor is stopped, or tires may wear out sooner.
4. The power steering mechanism makes the steering easier. Be careful when driving on a road at high speeds.

Trailer Electrical Outlet

A trailer electrical outlet is supplied for use with trailer or implement.

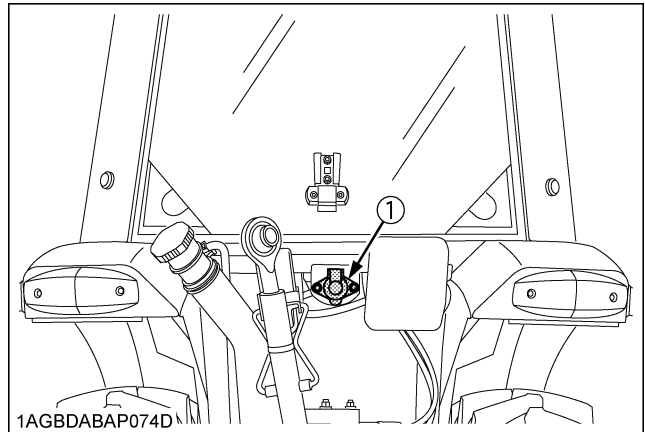

(1) Trailer electrical outlet

Function of each terminals in trailer electrical outlet

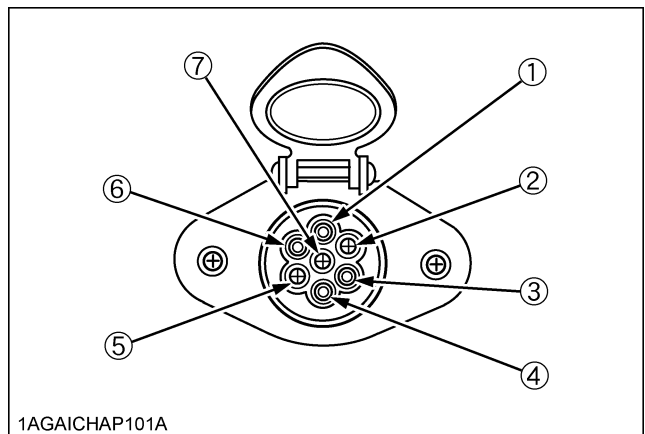

Terminal	Function
(1)	Ground
(2)	Tail light Sidemarker light Parking light
(3)	Turn signal light (LH)
(4)	Brake stop light
(5)	Turn signal light (RH)
(6)	Registration plate light
(7)	---

PTO

PTO OPERATION



WARNING

To avoid personal injury or death:

- Disengage PTO, stop engine, and allow all rotating components to come to a complete stop before connecting, disconnecting, adjusting, or cleaning any PTO driven equipment.

■ PTO Clutch Control Switch

The PTO clutch control switch engages or disengages the PTO clutch which gives the PTO independent control. Turn the switch to "ON" to engage the PTO clutch. Turn the switch to "OFF" to disengage the PTO clutch.

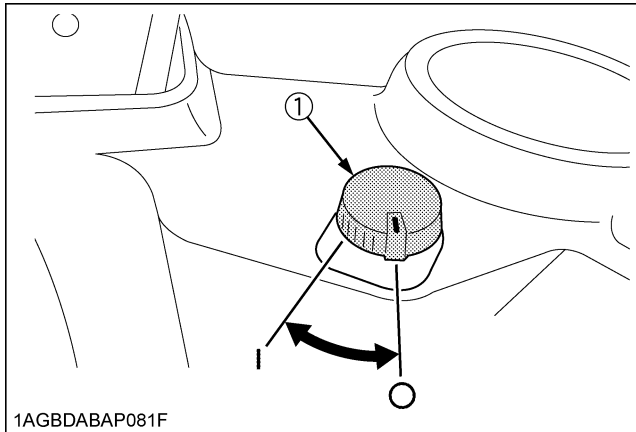

1AGBDABAP081F

(1) PTO clutch control switch | "ON" ○ "OFF"

◆ PTO Clutch Control Switch

To turn ON

While pushing the switch, turn clockwise to the " | " position and release your hand. (In the ON position, switch slightly rises itself.)

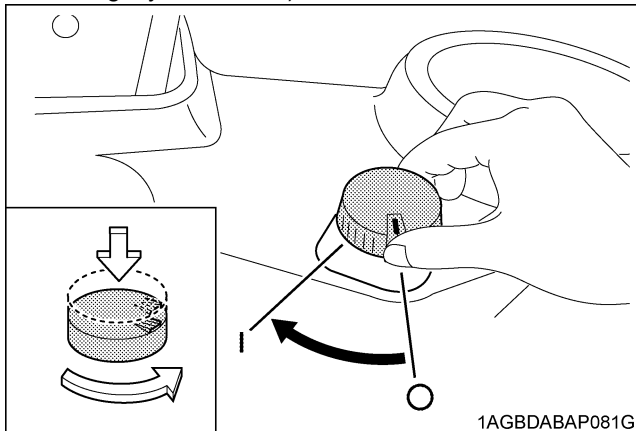

1AGBDABAP081G

To Turn OFF

Tap on top of the switch, and the switch will return to the OFF position.

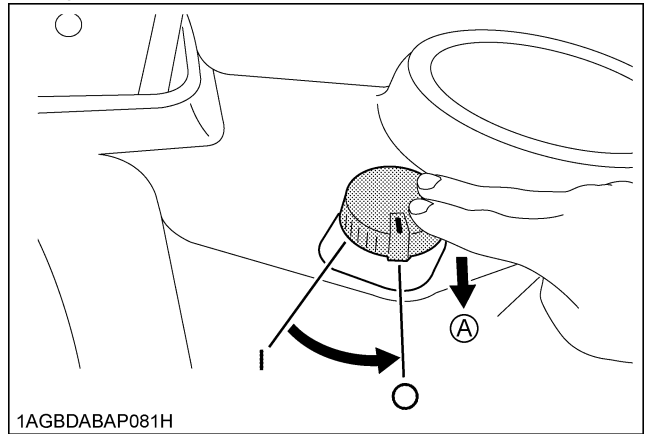

1AGBDABAP081H

(A) "PUSH"

IMPORTANT :

- To avoid shock loads to the PTO, reduce engine speed when engaging the PTO, then open the throttle to the recommended speed.

NOTE :

- Tractor engine will not start if PTO clutch control switch is in the engaged "ON" position.
- If the PTO system is engaged and you stand up from the seat, the warning buzzer will whistle for about 10 seconds after standing up. This is because the tractor is equipped with "Operator Presence Control System".

◆ PTO Clutch Indicator

The PTO clutch indicator turns on while PTO clutch control switch is in "ON" (Engage) position.

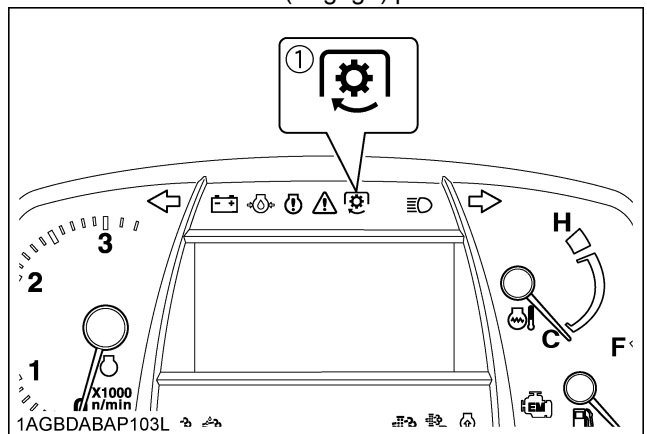

(1) PTO clutch indicator

■PTO Gear Shift Lever

WARNING

To avoid personal injury or death:

- Be sure to observe the PTO shaft speed prescribed for the individual implements. It is extremely dangerous to run an implement at high speed that is meant to be operated at low speed. Use only when this higher rpm is specifically recommended by the implement manufacturer.

The PTO gear shift lever can be set to either 540 rpm or 540E rpm positions.

Move this lever to either position with the PTO clutch control switch set to "OFF".

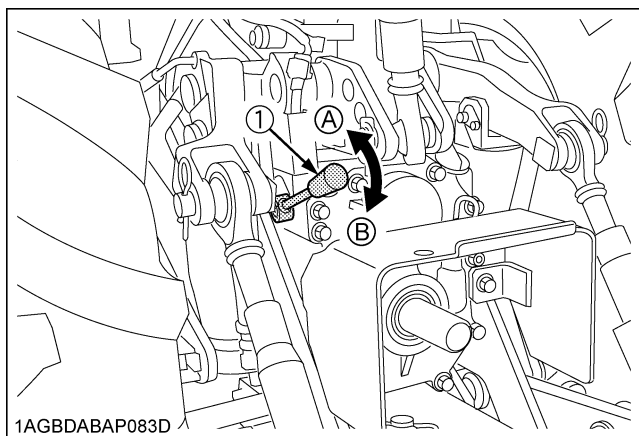

(1) PTO gear shift lever (A) 540 rpm (B) 540E rpm

NOTE :

- When light load, select the "540E" position for economical operation.

PTO gear shift lever	Engine speed rpm	PTO speed rpm
540	2385	540
540E	1764	540

■PTO Speed Limiter

NOTE :

- Move the PTO gear shift lever (if equipped) to "540E" and then turn on the PTO clutch control switch, and the rev-limiter indicator lights up on the meter panel.
- If the PTO clutch control switch is turned on with the engine rpm higher than the PTO 540E limit level, the PTO clutch indicator on the meter panel starts blinking and the PTO is disabled. After a while, the engine rpm automatically drops below the PTO 540E limit level and the PTO starts functioning. At the same time, the flashing PTO clutch indicator stays "ON".
- If the PTO clutch control switch is turned "OFF" but the engine rpm fails to rise with the throttle, return the engine rpm to a lower level. This enables acceleration again.

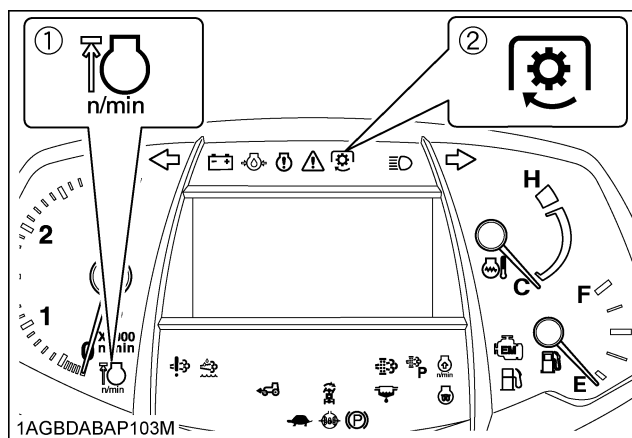

(1) Rev-limiter indicator (2) PTO clutch indicator

PTO	Limitation PTO / Engine speed (rpm)
540E	630 / 2057

■ LCD Monitor Message

1. The PTO rpm can be checked in the LCD monitor.
2. When the PTO system gets engaged (ON), the indicator lights up.

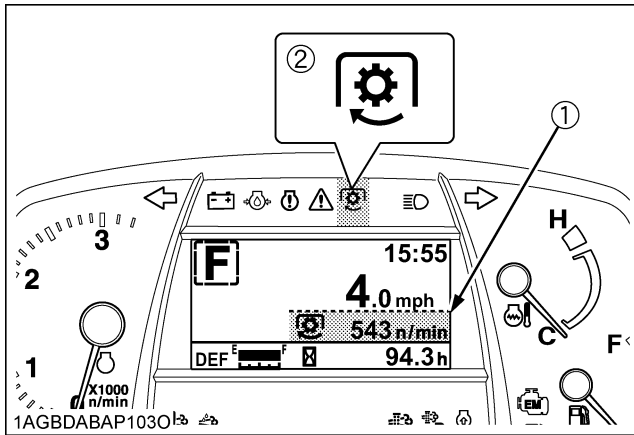

- (1) PTO speed
(2) PTO clutch indicator

■ PTO Shaft Cover and Shaft Cap

Keep the PTO shaft cover in place at all times. Replace the PTO shaft cap when the PTO is not in use. Before connecting or disconnecting a drive shaft to PTO shaft, be sure engine is "OFF".

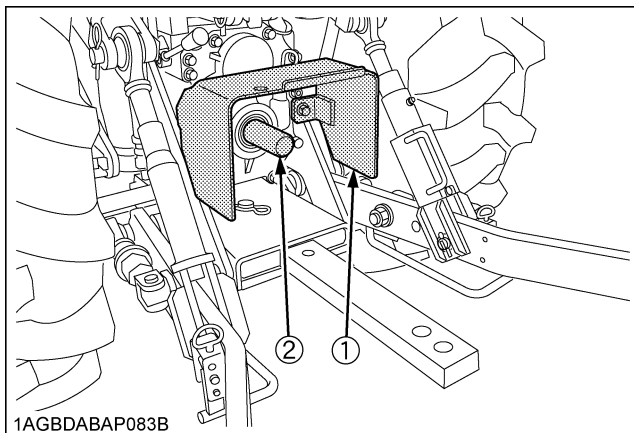

- (1) PTO shaft cover
(2) PTO shaft cap

IMPORTANT :

- The universal joint of the PTO drive shaft is technically limited in its moving angle. Refer to the PTO Drive Shaft Instructions for proper use.

3-POINT HITCH & DRAWBAR

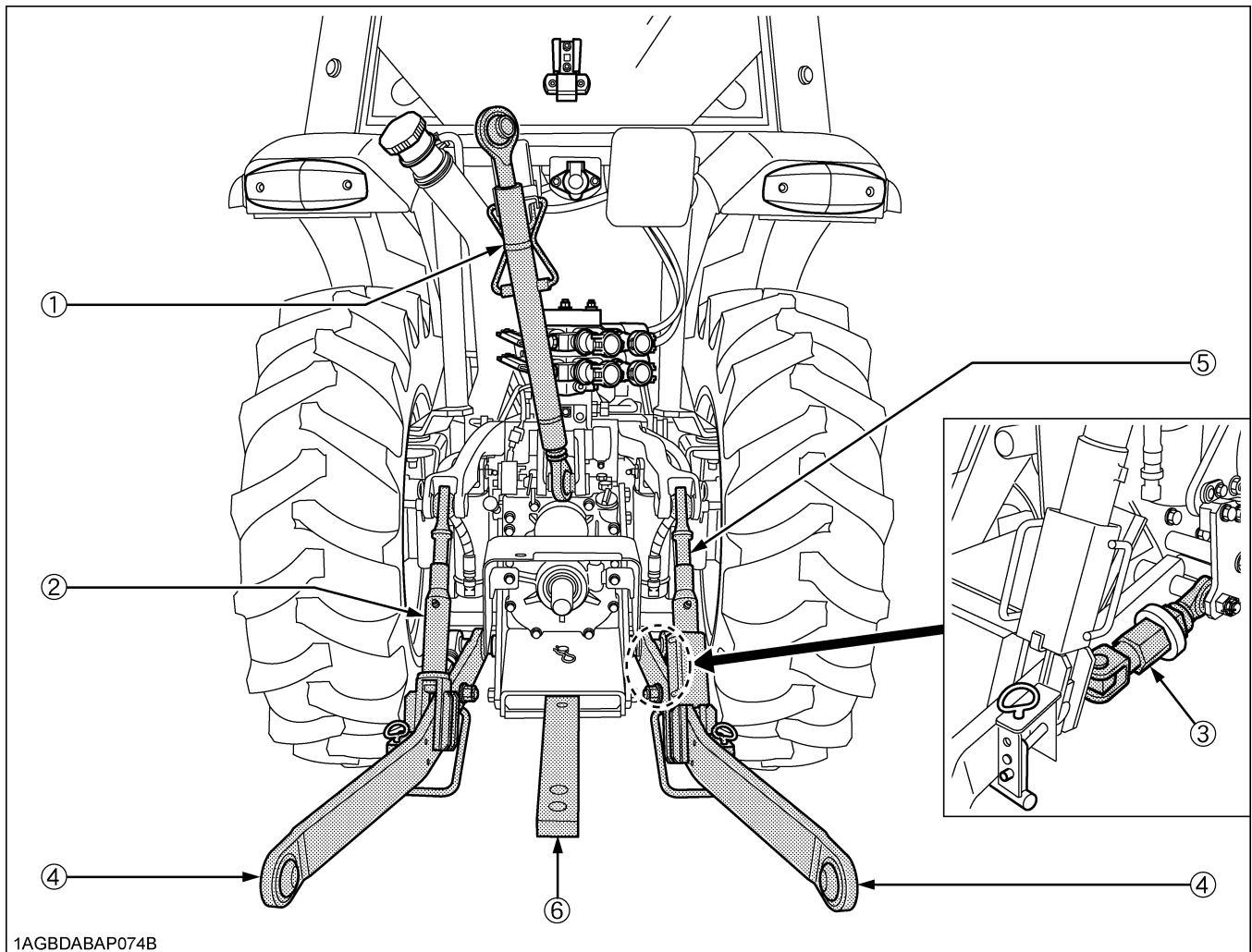

1AGBDABAP074B

- (1) Top link
- (2) Lifting rod (Left)
- (3) Stabilizer
- (4) Lower link
- (5) Lifting rod (Right)
- (6) Drawbar

3-POINT HITCH

1. Make preparations for attaching implement.

■ Selecting the holes of Lower Links

There are 2 holes in the lower links. For most operations the lifting rods should be attached to the (B) hole.

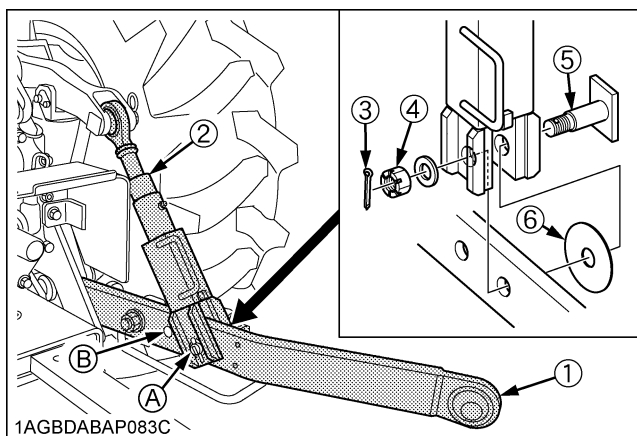

- | | | |
|-----------------|-------------------|-----------------|
| (1) Lower link | (4) Nut | holes: (A), (B) |
| (2) Lifting rod | (5) Lift rod pin | |
| (3) Split pin | (6) Thrust collar | |

NOTE :

- The lifting rods may be attached to (A) for greater lifting force.
- Install the thrust collar in the outside of the lower link.
- Tighten the nut by hand and fix the nut with the cotter pin.

■ Selecting the Top Link Mounting Holes

Select the proper set of holes by referring to the "Hydraulic Control Unit Use Reference Chart" in Hydraulic Unit section.

If the hydraulic unit is set for draft control, draft response is more sensitive when an implement is connected to the lower set of top link mounting holes. If draft control is not required, it is recommended to use the top set (1).

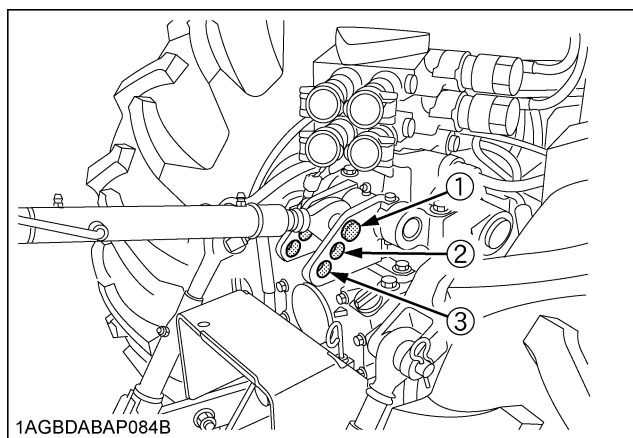

■ Drawbar

Remove the drawbar if a close mounted implement is attached.

2. Attaching and detaching implements

WARNING

To avoid personal injury or death:

- Be sure to stop the engine.
- Do not stand between tractor and implement unless parking brake is applied.
- Before attaching or detaching implement, locate the tractor and implement on a firm level surface.
- Whenever an implement or other attachment is connected to the tractor 3-point hitch, check full range of operation for interference, binding or PTO separation.
- Do not exceed maximum allowable length of either lifting rod, or the lifting rod will come apart and the 3-point equipment may fall.

■ Lifting Rod (Left)

By turning the rod itself, the lifting rod varies its length. When extending the rod, do not exceed the groove on the rod thread.

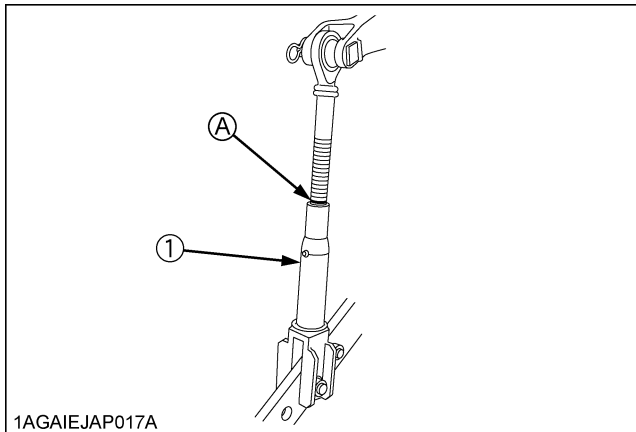

(1) Lifting rod

(A) "GROOVE"

■ Lifting Rod (Right)

WARNING

To avoid personal injury or death:

- Do not extend lifting rod beyond the groove on the thread rod.

1. To adjust the length of the lifting rod, lift the adjusting handle and turn to desired length.
2. After adjusting, the lifting rod adjusting handle must be returned and stored in the fore and aft position.
3. When extending the rod using adjusting handle, do not exceed the groove on the rod thread.

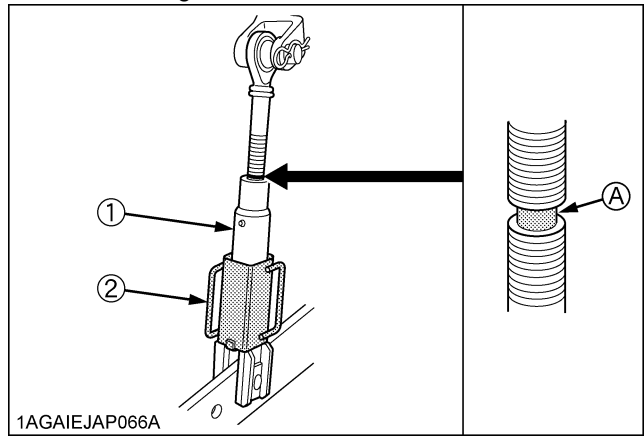

(1) Lifting rod

(2) Adjusting handle

(A) "GROOVE"

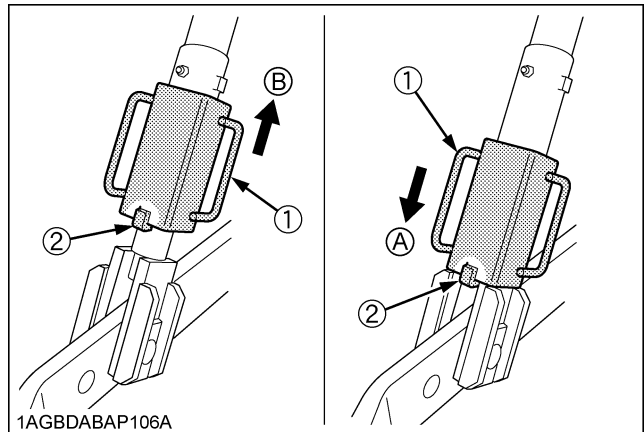

(1) Adjusting handle

(2) Lock pin

(A) "LOCK POSITION"

(B) "UNLOCK POSITION"

Top Link

1. Adjust the angle of the implement to the desired position by shortening or lengthening the top link.
2. The proper length of the top link varies according to the type of implement being used.

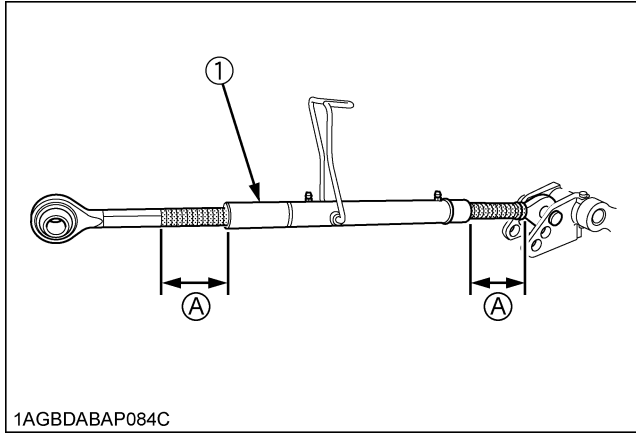

1AGBDABAP084C

(1) Top link

(A) "Length of the screw"

NOTE :

- The length of the screw at both ends of the top link must be the same always.

Stabilizer

The stabilizer is used to adjust the lower link width. Rotate the turnbuckle to adjust the stabilizer length. When adjusting, make sure both the stabilizers are equal in overall length.

◆ Turnbuckle locked position

After adjusting the stabilizer length, the turnbuckle must remain in the locked position.

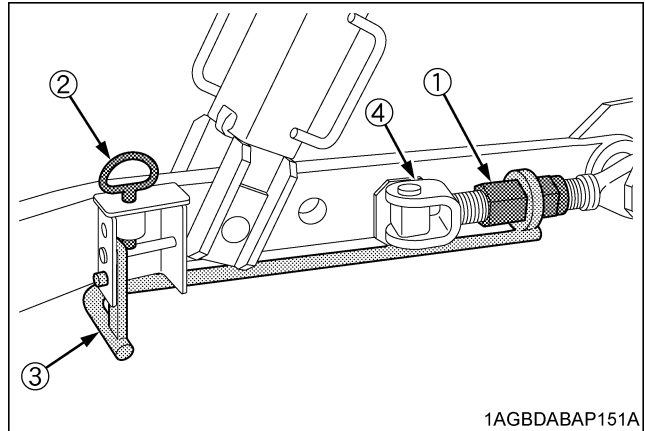

1AGBDABAP151A

- (1) Turnbuckle
- (2) Set-pin
- (3) Hex wrench handle
- (4) Stabilizer

◆ Turnbuckle unlocked position

1. Lift the set-pin and slide the hex wrench handle forward.

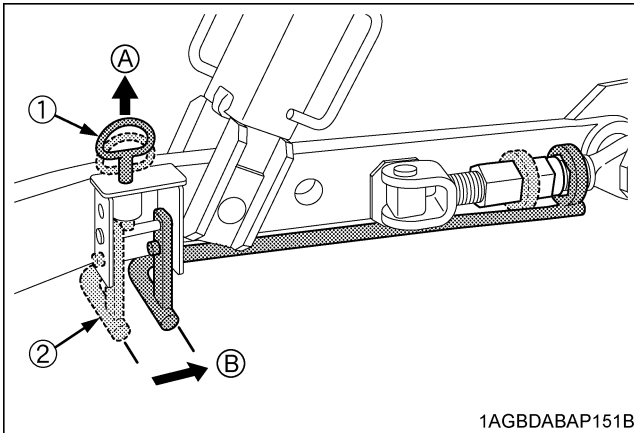

- (1) Set-pin (A) "Lift"
 (2) Hex wrench handle (B) "Slide forward"

2. Lower the set-pin and make sure the hex wrench handle cannot move past the set-pin tip.

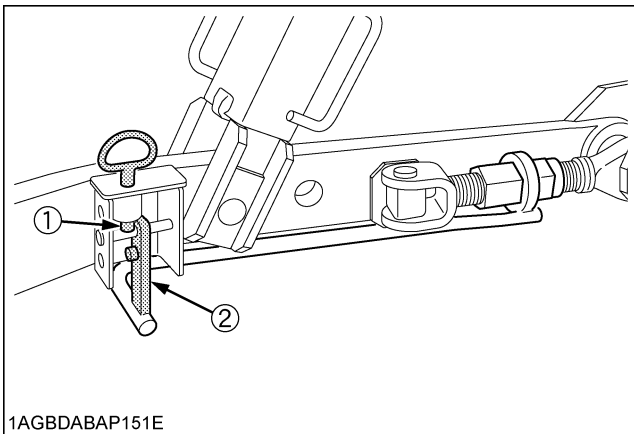

- (1) Set-pin
 (2) Hex wrench handle

◆ Rotating the turnbuckle

1. Use the hexagonal part of the wrench and the hex wrench handle to rotate the turnbuckle once.
2. Slide the hex wrench handle forward to release it from the turnbuckle.
3. Rotate the hex wrench handle and slide it backward until the hexagonal part is locked on the turnbuckle.
4. Repeat steps 1 to 3 until the desired stabilizer length is achieved.

Rotating	Stabilizer length	Lower link width
clockwise	Shorten	Widen
Counterclockwise	Lengthen	Narrow

[Example: Turnbuckle (RH) counterclockwise]

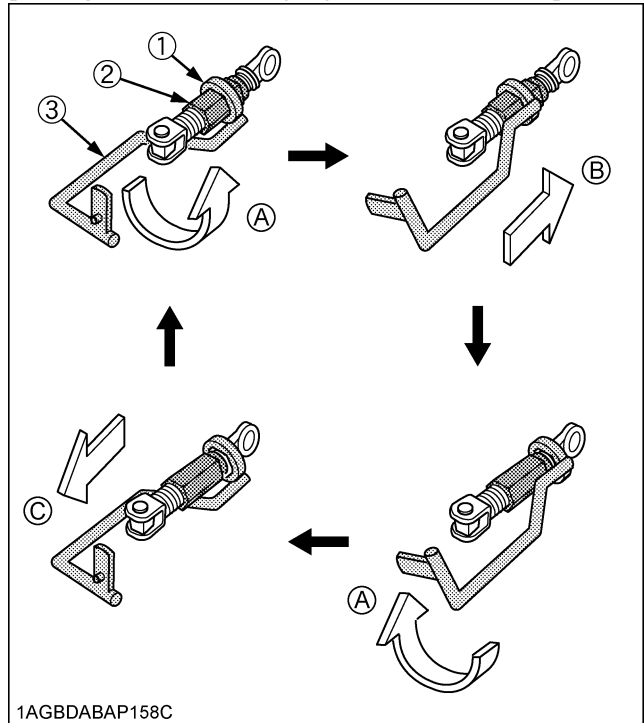

- (1) Hexagonal part (A) "Rotate"
 (2) Turnbuckle (B) "Slide forward"
 (3) Hex wrench handle (C) "Slide backward"

NOTE :

- Adjusting the left hand side stabilizer is done the same way as for the right hand side stabilizer.

DRAWBAR



WARNING

To avoid personal injury or death:

- Never pull from the top link, the rear axle or any point above the drawbar. Doing so could cause the tractor to tip over rearward causing personal injury or death.

■ Adjusting Drawbar Length

When towing an implement, it is recommended that the (A) hole in drawbar be utilized.

The drawbar load is specified in the "IMPLEMENT LIMITATIONS" section.

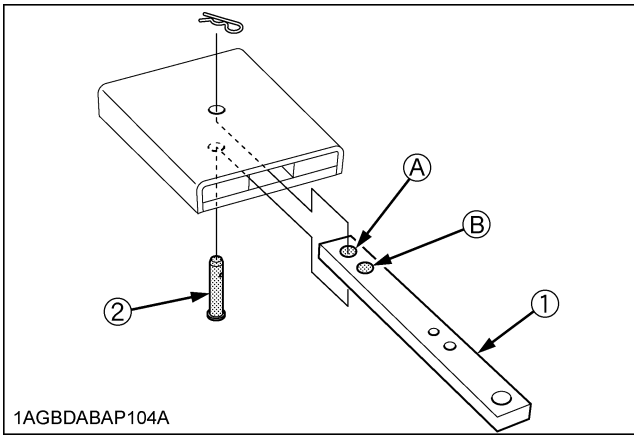
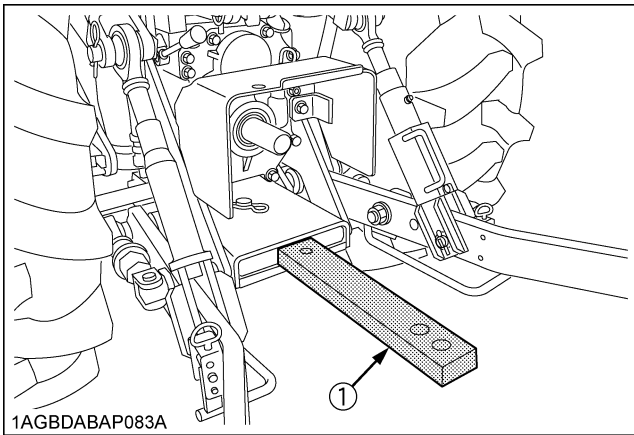

(1) Drawbar
(2) Pivot pin

Holes: (A), (B)

HYDRAULIC UNIT

The standard tractor has following hydraulic control systems as shown below. Therefore, use the most appropriate system for the implement you are using.

◆ 3-Point Hitch Control System

1. Position Control
2. Draft Control
3. Mixed Control
4. Float Control

◆ Remote Hydraulic Control System

IMPORTANT :

- Do not operate until the engine is warmed up. If operation is attempted when the engine is still cold, the hydraulic system may be damaged.
- If noises are heard when implement is lifting after the hydraulic control lever has been activated, the hydraulic mechanism is not adjusted properly. Unless corrected, the unit will be damaged. Contact your KUBOTA Dealer for adjustment.

3-POINT HITCH CONTROL SYSTEM



WARNING

To avoid personal injury or death:

- Before using the 3-point hitch controls, ensure that no person or object is in the area of the implement or 3-point hitch. Do not stand on or near the implement or between the implement and tractor when operating the 3-point hitch controls.

■ Position Control

This will control the working depth of 3-point hitch mounted implement regardless of the amount of pull required.

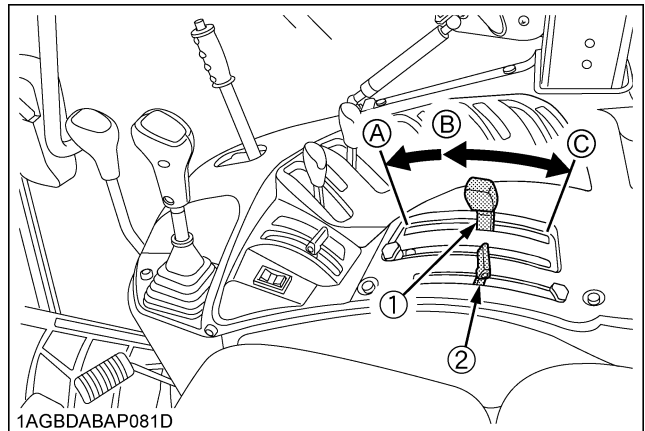

- (1) Position control lever
(2) Draft control lever

- (A) "FLOAT"
(B) "DOWN"
(C) "UP"

■ Draft Control

This will control the pull of the 3-point implement. As the load on the 3-point hitch changes due to various soil conditions, the draft control system automatically responds to these changes by either raising or lowering the implement slightly to maintain a constant pull. Place the position control lever in the lowest position and set the implement pull with the draft control lever.

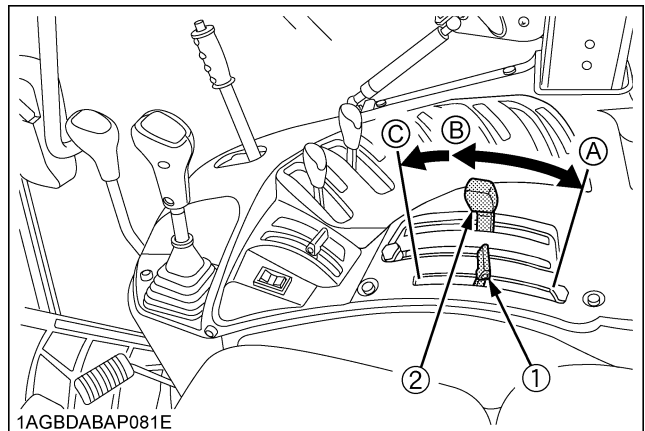

- (1) Draft control lever
(2) Position control lever

- (A) "SENSITIVE"
(B) "INSENSITIVE"
(C) "FLOAT"

■ Mixed Control

In draft control, when draft decreases, the implement automatically lowers to increase draft. However, the implement sometimes lowers too much. To limit the degree, the implement can be lowered, set the position control lever at the lowest working depth desired for the implement. Lower the draft control lever to the point where the implement is at the desired depth.

This stops the implement from going too deep and causing loss of traction and ground speed.

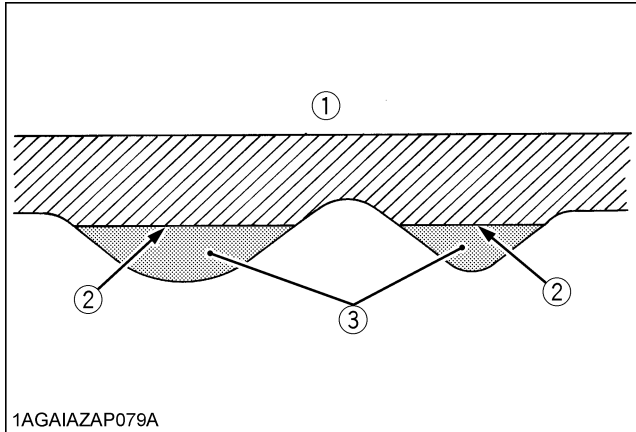

1AGAIAZAP079A

- (1) Ground surface
- (2) Implement penetration limit
- (3) Light soil

■ Float Control

Place both the draft control lever and the position control lever in the float position to make the lower links move freely along with the ground conditions.

■ 3-point Hitch Lowering Speed



WARNING

To avoid personal injury or death:

- Fast lowering speed may cause damage or injury. Lowering speed of implement should be adjusted to 2 or more seconds.

The lowering speed of the 3-point hitch can be controlled by adjusting the 3-point hitch lowering speed knob.

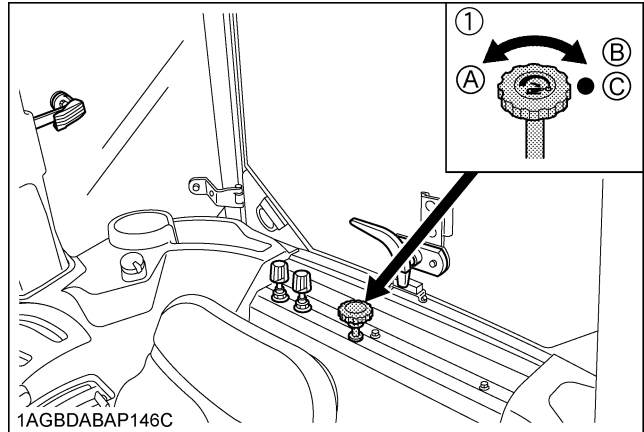

1AGBDABAP146C

- (1) 3-point hitch lowering speed knob

- (A) "FAST"
- (B) "SLOW"
- (C) "LOCK"

REMOTE HYDRAULIC CONTROL SYSTEM

The hydraulic auxiliary control valves can be installed up to 5 segments.

Remote Control Valve

There are 3 types of remote valves available for these models.

- **Double acting valve with detents and self cancelling:**
This valve may be placed in the detent mode. The lever will stay in this position until the pressure reaches a predetermined level or a cylinder reaches the end of its stroke. Then it will automatically return to neutral.
- **Double acting valve with float position:**
This valve may be placed in the float mode with the control lever all the way forward. The cylinder is free to extend or retract, letting an implement such as a loader bucket follow the ground.
- **Single/double acting valve:**
This valve can be utilized as single or double acting valve by adjusting the auxiliary control valve selector knob located on the valve.
 - 1) Turn the auxiliary control valve selector knob clockwise all the way to utilize as single acting valve.
 - 2) Turn the auxiliary control valve selector knob anticlockwise all the way to utilize as double acting valve.

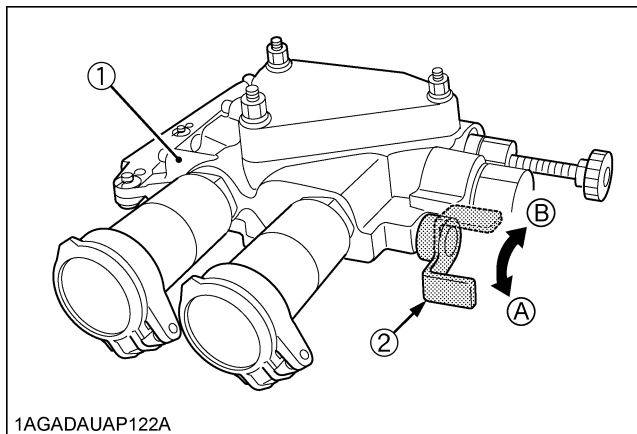

(1) Single / double acting valve
(2) Auxiliary control valve selector knob

(A) Double acting
(B) Single acting

Remote Control Valve Lever

The remote control valve lever directs pressurized oil flow to the implement hydraulic system.

[Example: Installing fifth segment valves]

1st	Double acting valve with detents and self cancelling (standard)
2nd	Double acting valve with detents and self cancelling (standard)
3rd	Double acting valve with float position (option)
4th	Double acting valve with float position (option)
5th	Single / Double acting valve (option)

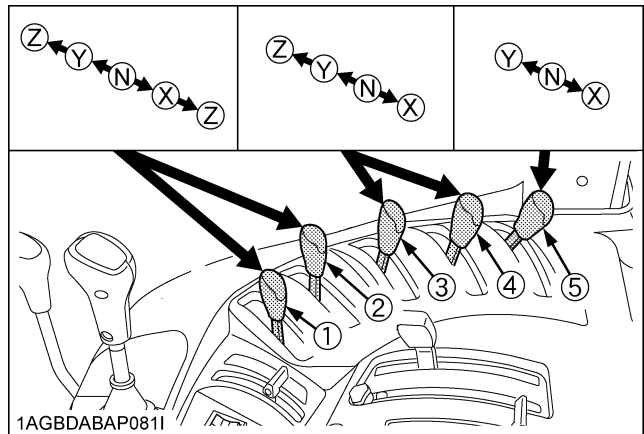

(1) Remote control valve lever 1
(2) Remote control valve lever 2
(3) Remote control valve lever 3
(4) Remote control valve lever 4
(5) Remote control valve lever 5

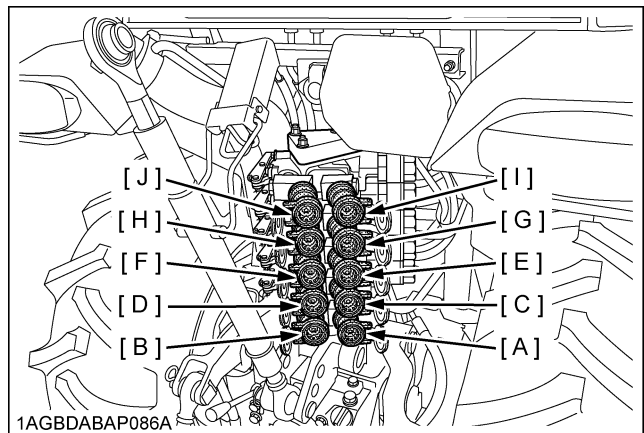

Pressure →
Returning ←

Lever (1)	Lever position			
	Z (detent)	Y	X	Z (detent)
Port	[A]	out →		in ←
	[B]	in ←		out →

Lever (2)	Lever position			
	Z (detent)	Y	X	Z (detent)
Port	[C]	out →		in ←
	[D]	in ←		out →

Lever (3)	Lever position				
	Z (detent)	Y	X		
Port	[E]	in	Float	out →	in ←
	[F]	out		in ←	out →

Lever (4)	Lever position				
	Z (detent)	Y	X		
Port	[E]	in	Float	out →	in ←
	[F]	out		in ←	out →

Lever (5)	Double-acting		Single-acting		
	Lever position				
	Y	X	Y	X	
Port	[G]	out →	in ←	-	-
	[H]	in ←	out →	in ←	out →

IMPORTANT :

- Do not hold the lever in the "pull" or "push" position once the remote cylinder has reached the end of the stroke, as this will cause oil to flow through the relief valve. Forcing oil through the relief valve for extended periods will overheat the oil.

NOTE :

- Connect the pressure of load side of implement cylinders to ports [B], [D], [F], [H] or [J] which have built in load check valve to prevent leak down.
- To use the single-acting cylinder with the float valve, connect this cylinder to the [B], [D], [F], [H] or [J] port. To extend a single-acting cylinder, pull the remote control valve lever rearward. To retract a cylinder, push it fully forward to the "FLOAT" position. Do not hold it in the down position, the transmission fluid may be overheat.

Remote Control Valve Coupler Connecting and Disconnecting

**WARNING**

To avoid personal injury or death:

- Stop the engine and relieve pressure before connecting or disconnecting lines.
- Do not use your hand to check for leaks.

Connecting

- Clean both couplers.
- Remove dust plugs.
- Insert the implement coupler to the tractor hydraulic coupler.
- Pull the implement coupler slightly to make sure couplers are firmly connected.

Disconnecting

- Lower the implement first to the ground to release hydraulic pressure in the hoses.
- Clean the couplers.
- Relieve pressure by moving hydraulic control levers with engine shut off. Pull the hose straight from the hydraulic coupler to release it.
- Clean oil and dust from the coupler, then replace the dust plugs.

NOTE :

- Your local KUBOTA Dealer can supply parts to adapt couplers to hydraulic hoses.

Adjusting the flow rate

**WARNING**

To avoid the possibility of personal injury or death be aware of the following when making adjustments:

- The 3-point hitch operation is influenced by the combination of the adjustment of the flow control valve and the engine speed.
- The 3-point hitch may rise slowly or not at all at low engine rpm.
- The 3-point hitch may rise suddenly if engine rpm is increased, or, flow control adjustment is changed.

◆ **Flow control**

The remote control valve with flow control may be added for the following purposes.

1. The attachments that are connected with the auxiliary control valve can be independently adjusted for flow rate.
2. To operate within limits, the remote control valves (1) and/or (2) and the 3-point hitch at the same time without one affecting the other.
3. To maintain within limits, the constant speed of an attachment (hydraulic motor RPM, for example) when connected to the remote control valves (1) and/or (2).

NOTE :

- At slower engine speeds the total hydraulic flow rate may be inadequate for simultaneous operation of the remote control valves (1) and/or (2) and the 3-point hitch, or operation of an attachment connected to the remote control valves (1)(2). Under these conditions, the engine speed must be increased to provide additional hydraulic flow.

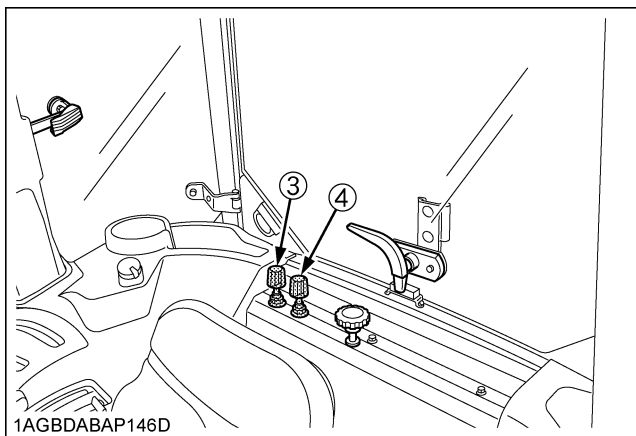
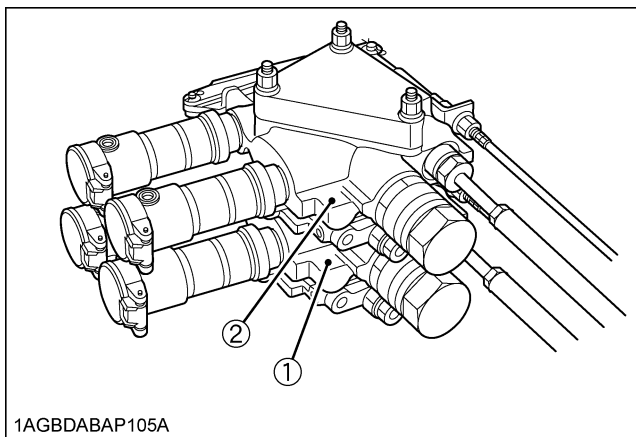

- (1) Remote control valve (1) with flow control
- (2) Remote control valve (2) with flow control
- (3) Flow control knob for valve (1)
- (4) Flow control knob for valve (2)

◆ **Adjusting the flow rate**

1. The flow rate for the remote control valves (1) and (2) can be adjusted.
2. Turn the flow control knobs (3) and/or (4) counterclockwise (A), and the flow rate for the remote control valves (1) and/or (2) increases. A clockwise turn (B) of the knob causes the flow to decrease. If the knob is turned all the way (C), there will be no flow.
3. To adjust the flow rate, set the engine speed to the operating RPM, turn the flow control knob once all the way clockwise (C), and then turn it gradually counterclockwise until a required flow rate is reached.

NOTE :

- Oil from the pump flows by priority to the auxiliary control valve. Surplus oil is fed to the 3-point hitch. With the auxiliary control valve at neutral, the total flow from the pump is fed to the 3-point hitch.

IMPORTANT :

- When there is no need to adjust the flow rate, turn the flow control knob all the way counterclockwise and keep it in this position.

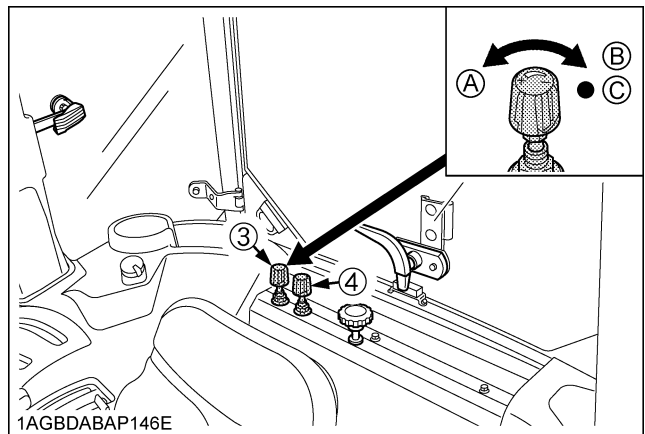
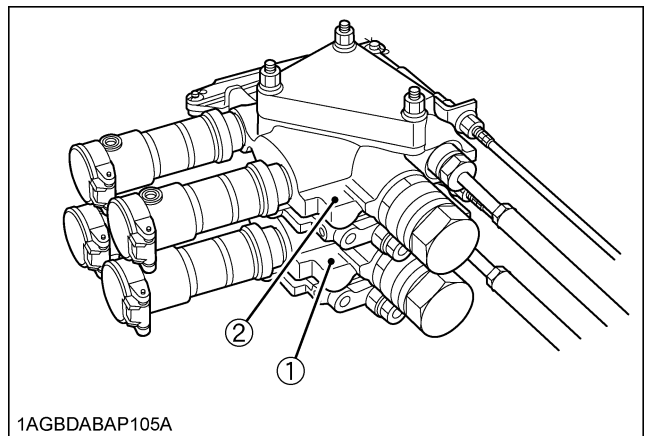

- (1) Remote control valve (1) with flow control
 - (2) Remote control valve (2) with flow control
 - (3) Flow control knob for valve (1)
 - (4) Flow control knob for valve (2)
- (A) "INCREASE"
(B) "DECREASE"
(C) "STOP"

Hydraulic Control Unit Use Reference Chart

In order to handle the hydraulics properly, the operator must be familiar with the following. Though this information may not be applicable to all types of implements and soil conditions, it is useful for general conditions.

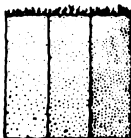
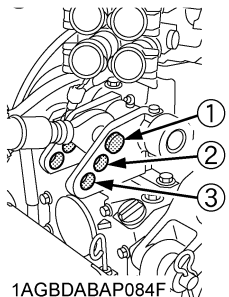
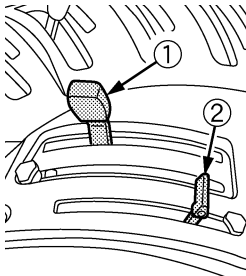
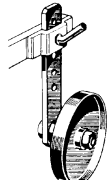
Implement	 1AGAIAZAP122A Soil condition	 1AGBDABAP084F Top link mounting holes	 1AGBDABAP081J (1) Position control lever (2) Draft control lever	 1AGAIAZAP070A Gauge wheel
Moldboard plow	Light soil Medium soil Heavy soil	3 2 or 3 2	Draft and Mixed control (Place the draft control lever to the suitable position and set the implement pull with the position control lever.)	YES/NO
Disc plow	---	2 or 3		
Harrow (spike, springtooth, disc type) Sub-soiler.....	---	2		
Weeder, ridger.....	---	1	Position control (Hold the draft control lever at the front most position during operation.)	YES
Earthmover, digger, scraper, manure fork, rear carrier.....				YES/NO
Mower (mid- and rear-mount type) Hayrake, tedder.....				NO

TIRES, WHEELS AND BALLAST

TIRES



WARNING

To avoid personal injury or death:

- Do not attempt to mount a tire on a rim. This should be done by a qualified person with the proper equipment.
- Always maintain the correct tire pressure. Do not inflate tires above the recommended pressure shown in the operator's manual.

IMPORTANT :

- Do not use tires other than those approved by KUBOTA.

NOTE :

- When optional different-diameter tires are fitted on the machine, the travel speed display mode must be changed. Otherwise the travel speed will not get correctly displayed. Such mode switching is also needed when the original tires are back on the machine.
(See "LCD MONITOR" in "OPERATING THE TRACTOR" section.)

■ Inflation Pressure

Though the tire pressure is factory-set to the prescribed level, it naturally drops slowly in the course of time. Thus, check it everyday and inflate as necessary.

	Tire sizes	Inflation Pressure
Front	8.0-16, 6PR	240 kPa (2.4 kgf/cm ² , 34 psi.)
	9.5-16, 6PR	196 kPa (2.0 kgf/cm ² , 29 psi.)
	27x8.5-15, 4PR	151 kPa (1.5 kgf/cm ² , 22 psi.)
	280/70R18	241 kPa (2.5 kgf/cm ² , 35 psi.)
Rear	12.4-24, 6PR	160 kPa (1.6 kgf/cm ² , 23 psi.)
	380/85R24, 6PR	138 kPa (1.4 kgf/cm ² , 20 psi.)
	380/85R24	165 kPa (1.7 kgf/cm ² , 24 psi.)
	320/85R20	160 kPa (1.6 kgf/cm ² , 23 psi.)
	480/65R24	160 kPa (1.6 kgf/cm ² , 23 psi.)

■ Dual Tires

Dual tires are not approved.

WHEEL ADJUSTMENT



WARNING

To avoid personal injury or death:

- When working on slopes or when working with trailer, set the wheel tread as wide as practical for maximum stability.
- Support tractor securely on stands before removing a wheel.
- Do not work under any hydraulically supported devices. They can settle, suddenly leak down, or be accidentally lowered. If necessary to work under tractor or any machine elements for servicing or adjustment, securely support them with stands or suitable blocking beforehand.
- Never operate tractor with a loose rim, wheel, or axle.

■ Safe Replacement of the Wheel

The wheel is heavy. Take the following precautions when removing the wheel.

1. Park the tractor on a solid, level place.
2. Apply the parking brake and use chocks.
3. In detaching the rear wheels, apply a wedge in place to keep the front axle from oscillating.
4. Use a jack or the like that withstands the relevant weight.
5. Use an appropriate tire remover.
6. Tighten the bolts and nuts to their specified torques.

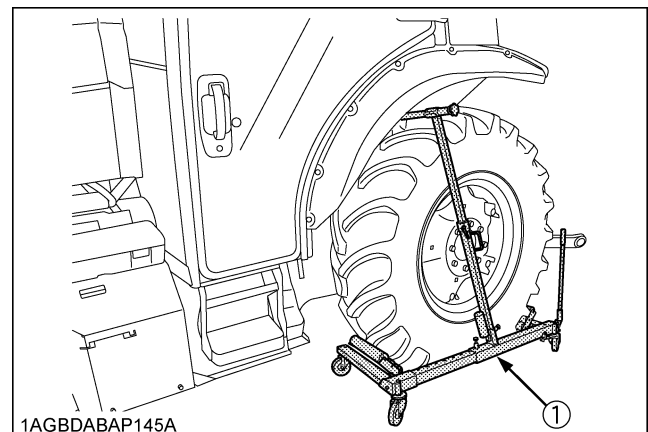

1AGBDABAP145A

(1) Tire remover

■ Front Wheels (with 4-wheel drive)

Front tread width can not be adjusted.

IMPORTANT :

- Always attach wheels as shown in the drawing.
- If not attached as illustrated, transmission parts may be damaged.
- When re-fitting or adjusting a wheel, tighten the bolts to the following torques then recheck after driving the tractor 200m (200 yards) and 10 times of shuttle movement by 5 m (5 yards), and thereafter according to service interval. (See "MAINTENANCE" section.)

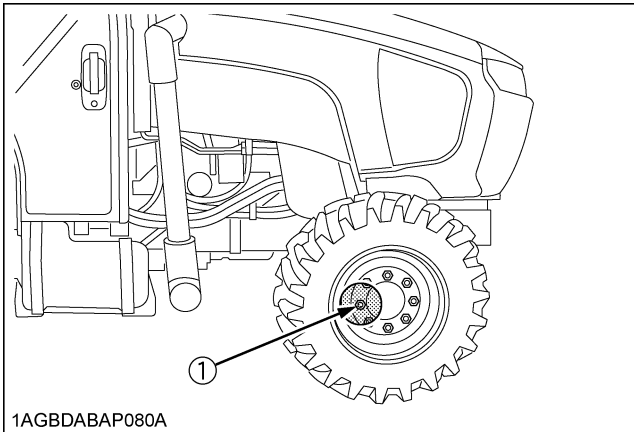

1AGBDABAP080A

(1) 260 to 304 N-m (26.5 to 31 kgf-m) (192 to 224 ft-lbs)

NOTE :

- Wheels with beveled or tapered holes: Use the tapered side of lug nut.

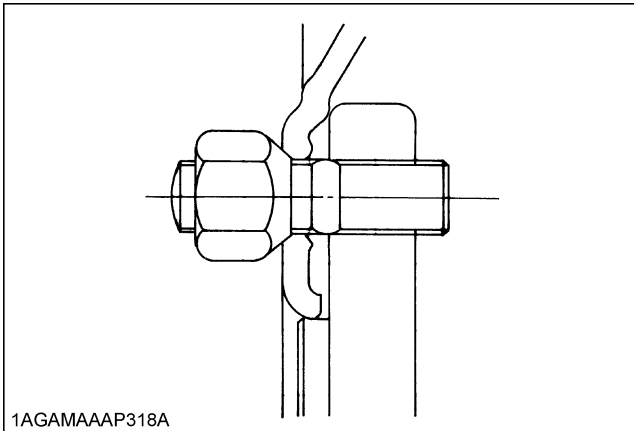

1AGAMAAAP318A



WARNING

To avoid personal injury or death:

- Before jacking up the tractor, park it on a firm and level ground and chock the rear wheels.
- Fix the front axle to keep it from pivoting.
- Select jacks that withstand the machine weight and set them up as shown below.

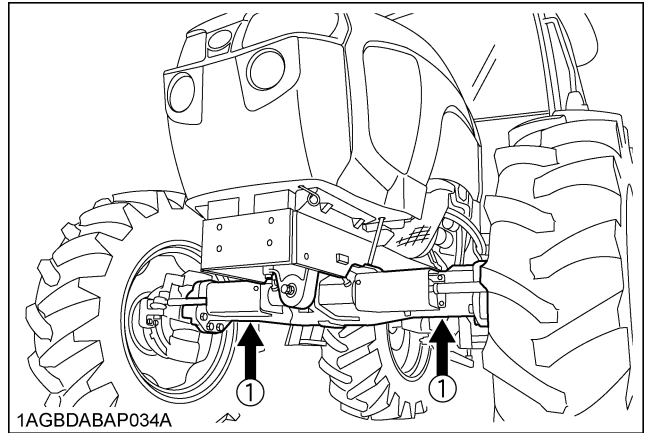

1AGBDABAP034A

(1) Jack points

■ Rear Wheels

Rear tread width can be adjusted as shown with the standard equipped tires.

To change the tread width

1. Remove the wheel rim and / or disk mounting bolts.
2. Change the position of the rim and / or disk (right and left) to the desired position, and tighten the bolts.

IMPORTANT :

- Always attach wheels as shown in the drawing.
- If not attached as illustrated, transmission parts may be damaged.
- When re-fitting or adjusting a wheel, tighten the bolts to the following torques then recheck after driving the tractor 200m (200 yards) and 10 times of shuttle movement by 5 m (5 yards), and thereafter according to service interval. (See "MAINTENANCE" section.)

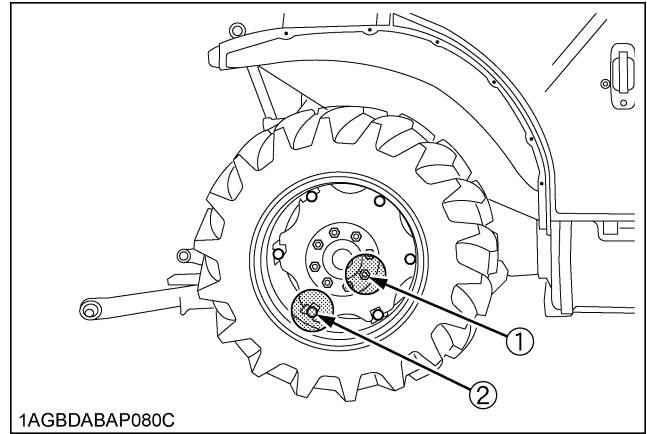

(1)	N-m (kgf-m) [ft-lbs]	
	(2) Steel disk	Cast iron disk
260 to 304 (26.5 to 31.0) [191.8 to 224.2]	244 (24.9) [180]	260 to 304 (26.5 to 31.0) [191.8 to 224.2]

12.4-24	970 mm (38.2 in.)	1025 mm (40.4 in.)	1205 mm (47.4 in.)	1255 mm (49.4 in.)	1330 mm (52.3 in.)	1385 mm (54.5 in.)
380/85R24	---	1115 mm (43.9 in.)	1110 mm (43.7 in.)	1350 mm (53.1 in.)	1240 mm (48.8 in.)	---
380/85R24 Cast	---	1160 mm (45.7 in.)	1085 mm (42.7 in.)	1375 mm (54.1 in.)	1160 mm (45.7 in.)	---
480/65R24	---	1155 mm (45.5 in.)	1090 mm (42.9 in.)	1370 mm (53.9 in.)	1165 mm (45.9 in.)	---

320/85R20	1055 mm (41.5 in.)	1160 mm (45.7 in.)	1270 mm (50.0 in.)



WARNING

To avoid personal injury or death:

- Before jacking up the tractor, park it on a firm and level ground and chock the front wheels.
- Fix the front axle to keep it from swinging.
- Select a jack that withstands the machine weight and set it up as shown below.

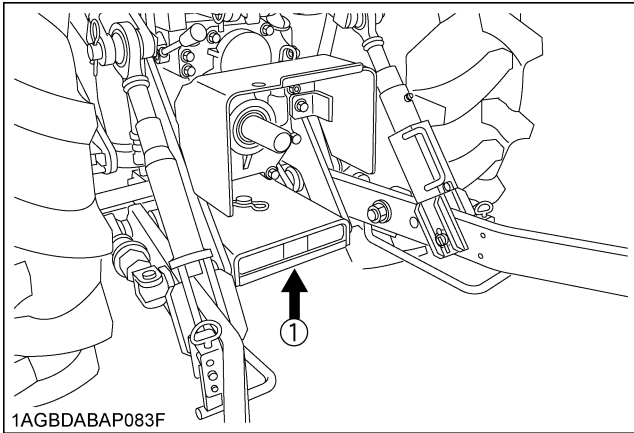

1AGBDABAP083F

(1) Jack point

BALLAST



WARNING

To avoid personal injury or death:

- Additional ballast will be needed for transporting heavy implements. When the implement is raised, drive slowly over rough ground, regardless of how much ballast is used.
- Do not fill the front wheels with liquid to maintain steering control.

■ Front Ballast

Add weights if needed for stability and improve traction. Heavy pulling and heavy rear mounted implements tend to lift front wheels.

Add enough ballast to maintain steering control and prevent tip over. Remove weight when no longer needed.

◆ Front End Weights (option)

The front end weights can be attached to the bumper.

See your implement operator's manual for required number of weights or consult your local KUBOTA Dealer to use.

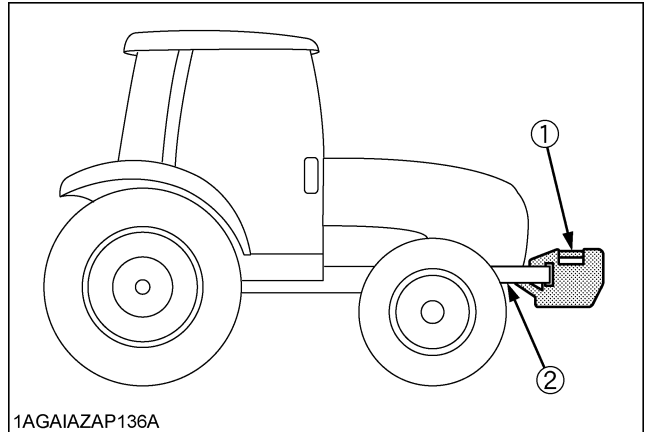

1AGAIAZAP136A

(1) Front end weights

(2) Bumper

IMPORTANT :

- Do not overload tires.
- Add no more weight than indicated in chart.

Maximum weight	47 kg x 10 pieces (1036 lbs.)
----------------	----------------------------------

■ Rear Ballast

Add weight to rear wheels if needed to improve traction or for stability. The amount of rear ballast should be matched to job and the ballast should be removed when it is not needed.

The weight should be added to the tractor in the form of liquid ballast, rear wheel weights or a combination of both.

◆ Rear Wheel Weights (option)

The rear wheel weights can be attached to the rear wheel. See your implement operator's manual for required number of weights or consult your local KUBOTA Dealer to use.

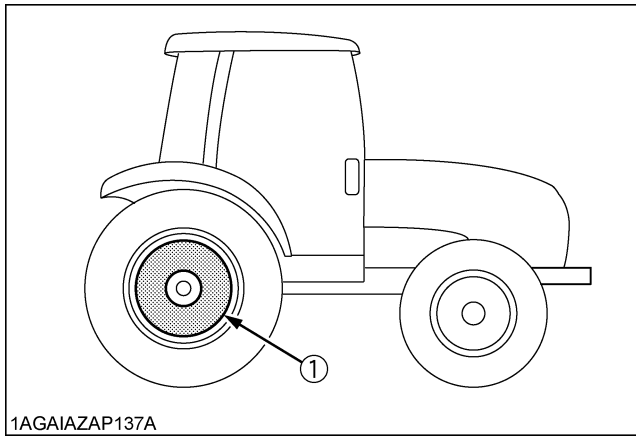

(1) Rear wheel weights

IMPORTANT :

- Do not overload tires.
- Add no more weight than indicated in chart.

Rear wheel weight	47 kg x 2 pieces (206 lbs.)
-------------------	--------------------------------

◆ Liquid Ballast in Rear Tires

Water and calcium chloride solution provides safe economical ballast. Used properly, it will not damage tires, tubes or rims. The addition of calcium chloride is recommended to prevent the water from freezing. Use of this method of weighting the wheels has the full approval of the tire companies. See your tire dealer for this service.

Liquid weight per tire (75 Percent filled)

Tire sizes	12.4-24	380/85R24
Slush free at -24 °C (-11 °F) Solid at -47 °C (-53 °F) [Approx. 1.5 kg (3.5 lbs.) CaCl ₂ per 4 L (1 gal.) of water]	139.7 kg (308 lbs.)	215.0 kg (474 lbs.)
Slush free at -47 °C (-53 °F) Solid at -52 °C (-62 °F) [Approx. 2.25 kg (5 lbs.) CaCl ₂ per 4 L (1 gal.) of water]	151.0 kg (333 lbs.)	230.0 kg (507 lbs.)

IMPORTANT :

- Do not fill tires with water or solution more than 75% of full capacity (to the valve stem level).

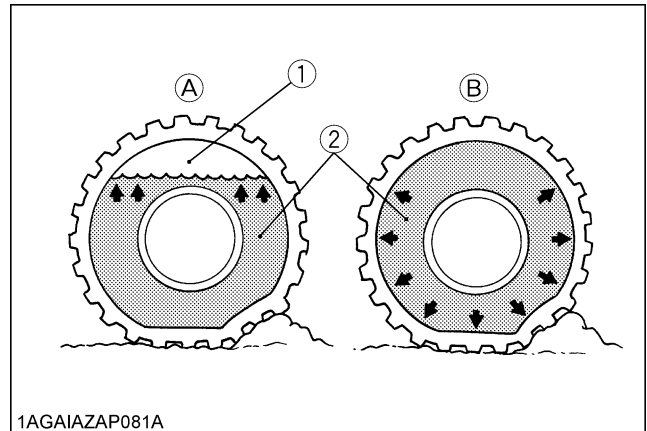

- (1) Air (A) Correct-75% Air compresses like a cushion
 (2) Water (B) Incorrect-100% Full Water can not be compressed

CAB OPERATION

DOOR AND WINDOW

■ Locking and Unlocking the Door

From the outside Insert the key into the door lock. Turn the key clockwise to unlock the door. To lock the door, turn the key in the opposite direction. The key can be removed when it is in the vertical direction.

From the inside Push down the lock knob to lock the door. Pull up the lock knob to unlock the door.

■ Opening the Door

From the outside Unlock the door, and pull the outer door handle.

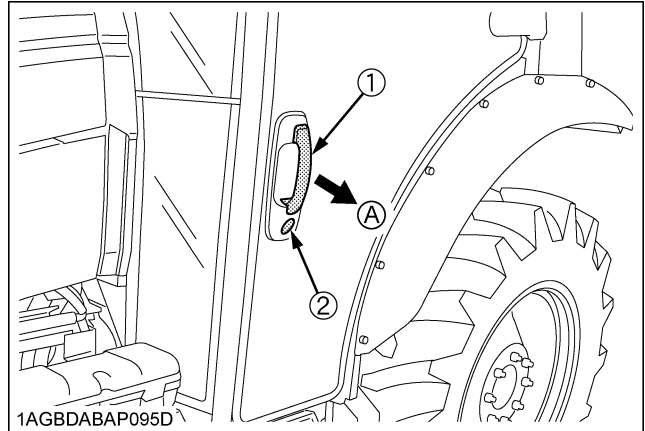

(1) Outer door handle (A) "PULL"
(2) Door lock

From the inside Unlock the door and pull the inner door handle.

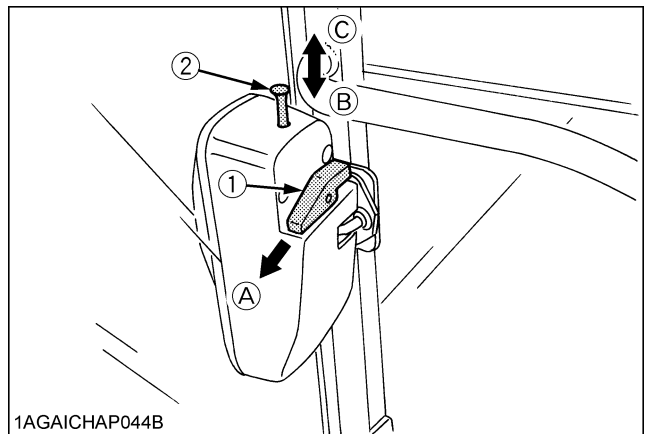

(1) Inner door handle (A) "PULL"
(2) Lock knob (B) "PUSH" (Lock)
(C) "PULL" (Unlock)

■Rear Window

Turn the rear window handle clockwise to the vertical position and push the handle. The rear window is opened by the gas spring cylinder.

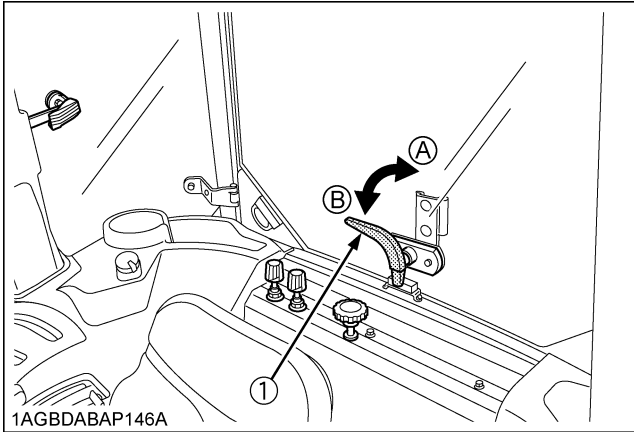

(1) Rear window handle

(A) "OPEN"
(B) "CLOSE"

■Side Window

Pull the side window handle and push the side window to open the window.

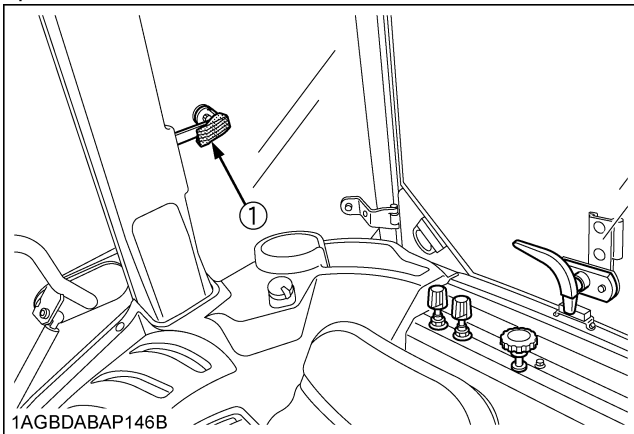

(1) Side window handle

DOME LIGHT

■Dome Light

Sliding the dome light switch will give the following light condition:

- OFF The light does not turn on when the door is opened.
- DOOR The light turns on when the door (LH) is opened. It turns off when the door (LH) is closed.
- ON The light remains on regardless of the door position.

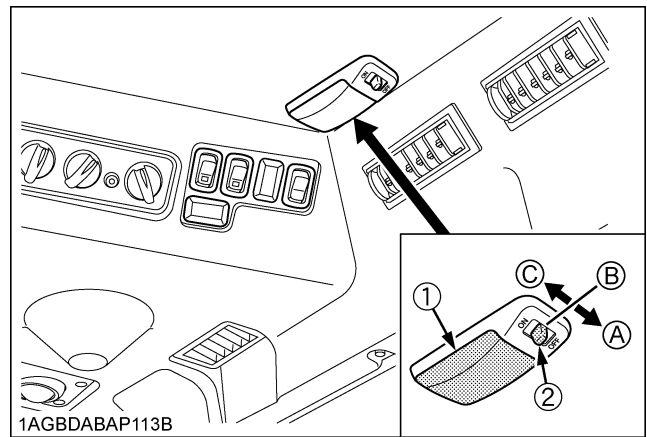

(1) Dome light
(2) Dome light switch

(A) "OFF"
(B) "DOOR"
(C) "ON"

IMPORTANT :

- The battery will discharge if the dome light remains on. Be sure to check the dome light switch position and/or door closure.

WORK LIGHT



WARNING

To avoid personal injury or death:

- Do not operate on roads with work lights on. Work lights may blind or confuse operators of oncoming vehicles.

Work Light Switch

Turn on the key switch and press the top half of the work light switch. The work light and the switch's indicator light up. Press the bottom half of the work light switch to turn off the light and indicator.

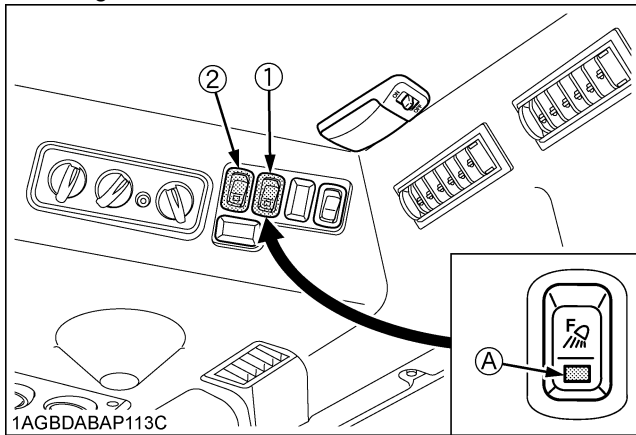

(1) Front work light switch
(2) Rear work light switch

(A) Indicator for work lights

Front Work Light

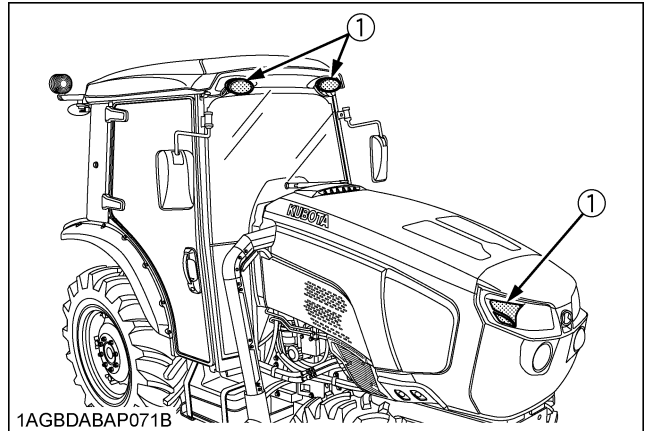

(1) Front work light

Rear Work Light

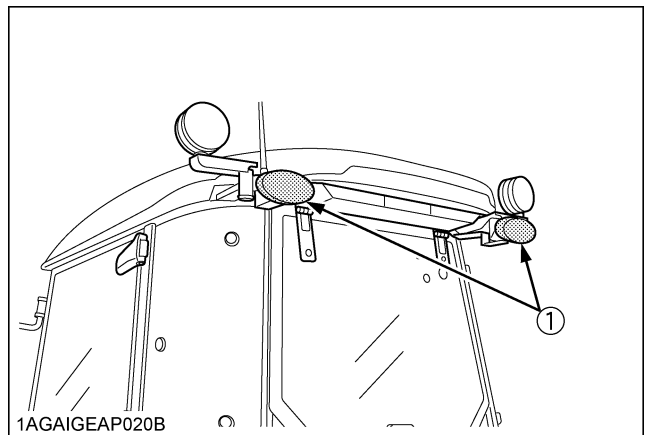

(1) Rear work light

WIPER

■ Front Wiper / Washer Switch

1. Turn on the key switch and press the top half of the wiper switch to the first step, and the wiper is activated. When the switch is pressed further to the second step, washer liquid jets out. The jetting continues while the switch is pressed and the wiper is activated continuously.
2. Press the bottom half of the wiper / washer switch, washer liquid only jets out.

■ Rear Wiper / Washer Switch (if equipped)

1. Turn on the key switch and press the top half of the wiper switch to the first step, and the wiper is activated. When the switch is pressed further to the second step, washer liquid jets out. The jetting continues while the switch is pressed and the wiper is activated continuously.
2. Press the bottom half of the wiper / washer switch, washer liquid only jets out.

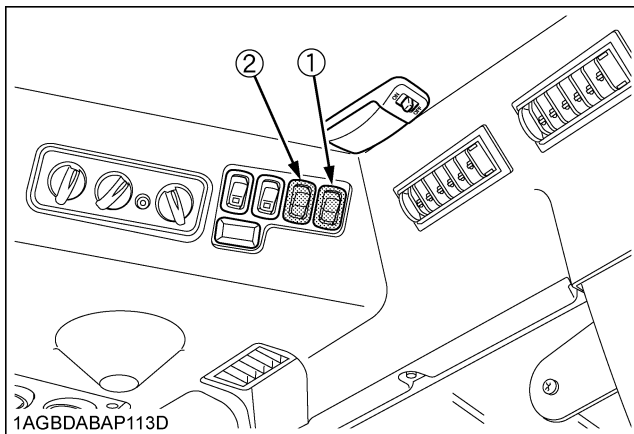

(1) Front wiper / washer switch
(2) Rear wiper / washer switch (if equipped)

IMPORTANT :

- Do not activate the wipers when the windows are dry, they may be scratched. Be sure to jet washer liquid first and then activate the wipers.

■ Using the Wipers in Cold Season

1. While not used in cold season, keep the wiper blades off the windshield to prevent them from being stuck with ice.
2. If the windshield is covered with snow, scrape it off the windshield before using the wipers.
3. If the wiper blades are stuck on the windshield with ice and fail to move, be sure to turn the main key switch to "OFF" and remove the ice off the blades. Then place the main key switch back to "ON".
4. When commercially available cold-season wiper blades are used, make sure their size is the same as or smaller than that of the standard ones.

IMPORTANT :

- In cold season, the wiper blades and the wiper motor might get overloaded causing damage. To avoid this, be sure to take the above precautions.

AIR CONDITIONER

■ Airflow

Air in the CAB and fresh air introduced into the CAB flow as shown below. Adjust the 8 air ports to obtain the desired condition.

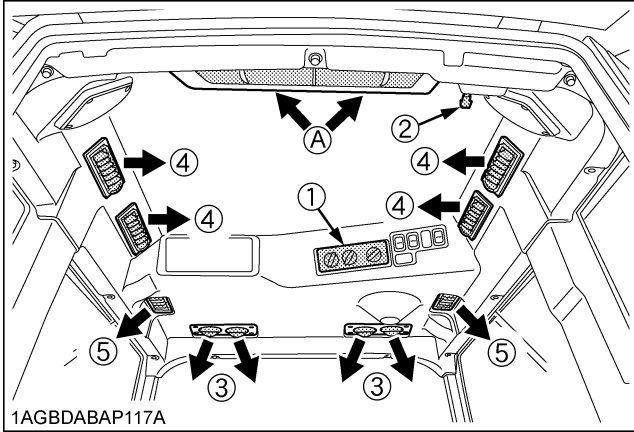

- (1) Control panel
 - (2) Recirculation / Fresh air selection lever
 - (3) Front air outlet (defrost, windshield, foot area)
 - (4) Side air outlet (face, back area)
 - (5) Door air outlet (door area)
- (A) Inner air recirculation

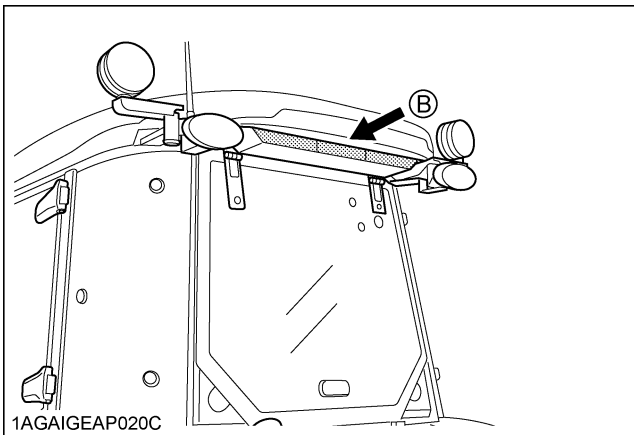

(B) Fresh air inlet

IMPORTANT :

- Do not pour water directly into the fresh air port while washing the vehicle.

■ Air Control Vent

◆ Front air outlet

The front air outlets can be independently adjusted as required. To defrost the windshield, rotate the outlets toward the windshield.

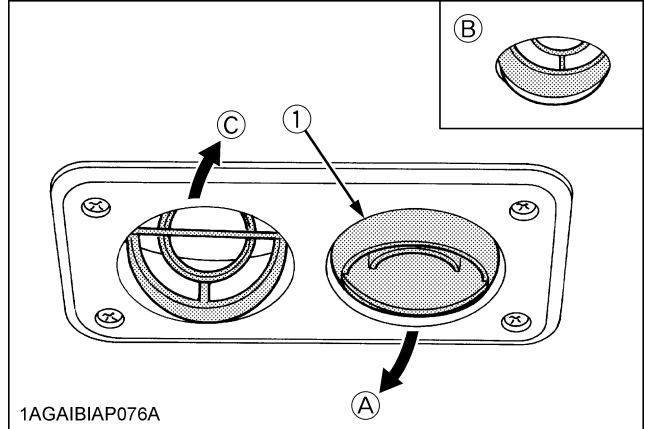

- (1) Front air outlet
- (A) "WINDSHIELD"
- (B) "CLOSED"
- (C) "CHEST AREA"

◆ Side air outlet and door air outlet

The side and door air outlets can be adjusted to direct air on to the operator, door window or the rear of the CAB.

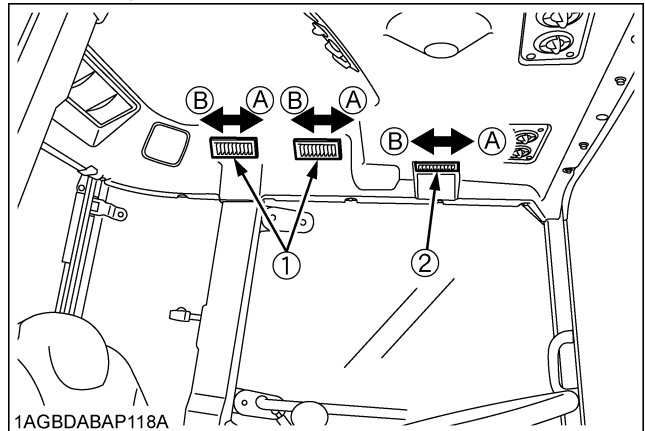

- (1) Side air outlet
- (2) Door air outlet
- (A) "OPEN"
- (B) "SHUT"

NOTE :

- If the airflow rate at the face is too low, close the door air outlet.





CAUTION

To avoid personal injury;

- Replace the water hoses every 4 years.
- Daily inspection
Have the tractor repaired immediately if any of the following defects are discovered. (Such defects may cause burns or injury. They may also cause engine seizure or other serious failure.)
 - Scratches, cracks or swelling in water hoses.
 - Water leakage at water hose joints.
 - Missing or damaged water hose protective wrap or grommets.
 - Loose mounting bolts, damaged brackets.
- Do not touch the water hoses and the heater with your hand. You may get burned.
- If the window fails to defrost in extreme conditions or becomes cloudy when dehumidifying the CAB, wipe off moisture with a soft cloth.
- Do not block all the air outlets of the air conditioner. A problem could occur.

◆ Recirculation / fresh air selection lever

FRESH AIR: Set the lever to the  position, and fresh air will flow into the CAB. This is helpful when you work in dusty conditions or if the glass windows get foggy.

RECIRCULATION: Set the lever to the  position, and the in-CAB air will be recirculated. This is useful for cooling or heating the CAB quickly or keeping it extra cool or warm.

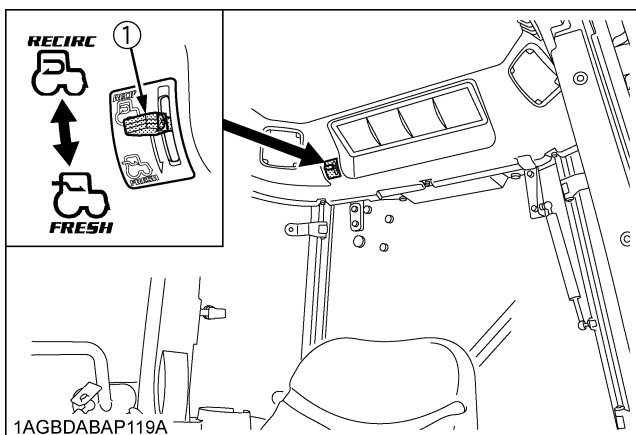

(1) Recirculation / fresh air selection lever



NOTE :

- When heating, do not keep the lever at the "RECIRCULATION" position for a long time. The windshield easily gets foggy.
- While working in a dusty conditions, keep the lever at the "FRESH AIR" position. This increases the pressure in the CAB, which helps prevent dust from coming into the CAB.

Control Panel

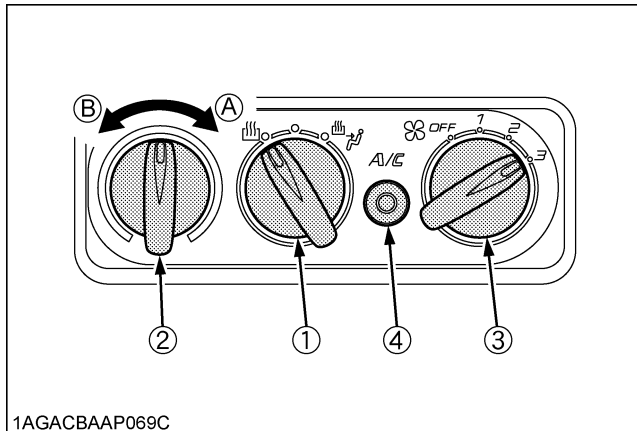

- (1) Mode switch
- (2) Temperature control dial
- (3) Blower switch
- (4) Air conditioner switch with indicator light
- (A) "WARM"
- (B) "COOL"

Mode Switch

Set the mode switch to the desired position.

- Air is blown from the front and side air outlets.
- Air is blown from only the front air outlets.
 - With this switch at the middle position, air is blown weaker from the side air outlets (head) and stronger from the front air outlets.

Temperature Control Dial

Set this dial at the desired position to obtain the optimum air temperature. Turn the dial in the "WARM" direction to obtain warmer air. Turn it in the "COOL" direction to obtain cooler air.

Blower Switch

Air volume can be changed in 3 steps. At the "3" position, the largest air volume is obtained.

Air Conditioner Switch

Push this switch to activate the air conditioner. An indicator light will light up when the switch is set to "ON". Push the switch again to turn the air conditioner off, in which case the indicator light will be off.

NOTE :

- With the blower switch at the "OFF" position, the indicator light will not light up even when the air conditioner switch is set to "ON".

IMPORTANT :

- To operate the air conditioner after the tractor has not been used for one week or longer, run the engine at idling speed first and then set the air conditioner switch to "ON". Keep this for one minute or so. If the air conditioner switch is set to "ON" with the engine running at high rpm, the compressor may get in trouble.

Operation

Heating

1. Set the mode switch to the , or position.
2. Set the recirculation / fresh air selection lever to the "FRESH AIR" position. To raise the temperature in the CAB quickly, set this lever to the "RECIRCULATION" position.
3. Adjust the blower (1/2/3) switch and the temperature control dial to achieve a comfortable temperature level.

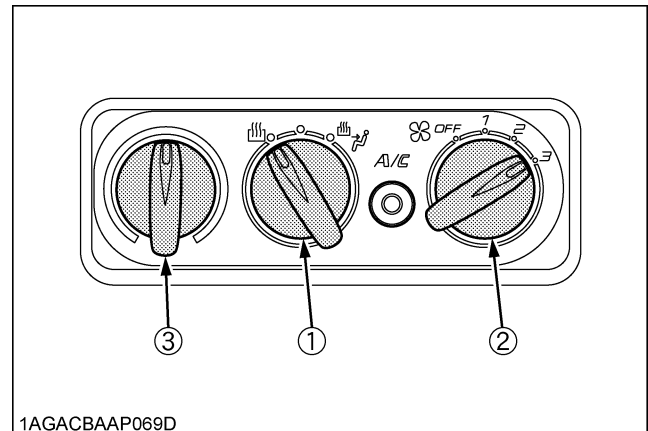

- (1) Mode switch
- (2) Blower switch
- (3) Temperature control dial

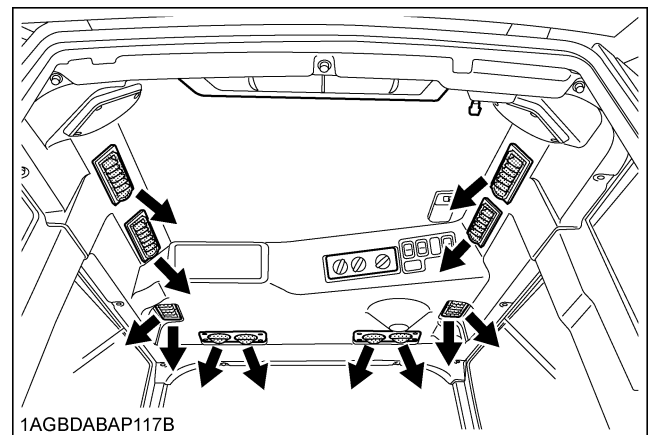

◆ **Cooling or dehumidifying-heating**

1. Set the mode switch to the  position.
2. Set the recirculation / fresh air selection lever to the "FRESH AIR" position. To lower the temperature in the CAB quickly, set this lever to the "RECIRCULATION" position.
3. Press and turn on the air-conditioner switch with indicator.
4. Turn on the blower (1/2/3) switch.
5. Adjust the temperature control dial to the "COOL" or an intermediate position to achieve a comfortable temperature level.

NOTE :

- In summer when the heater is not used, keep the temperature control dial at the max "COOL" (end of counterclockwise) position. Otherwise, hot air will raise the temperature in the CAB.

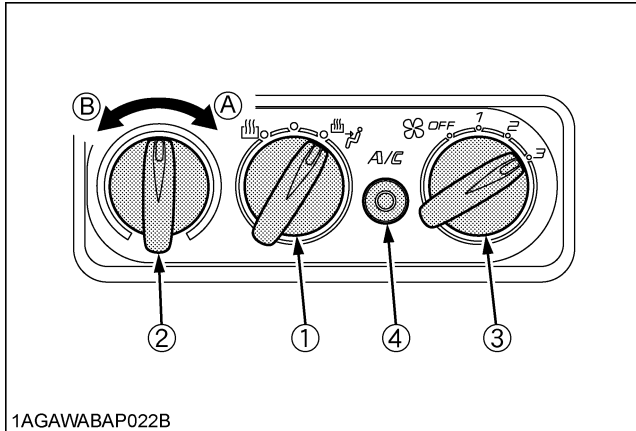

- | | |
|---|------------|
| (1) Mode switch | (A) "WARM" |
| (2) Temperature control dial | (B) "COOL" |
| (3) Blower switch | |
| (4) Air conditioner switch with indicator light | |

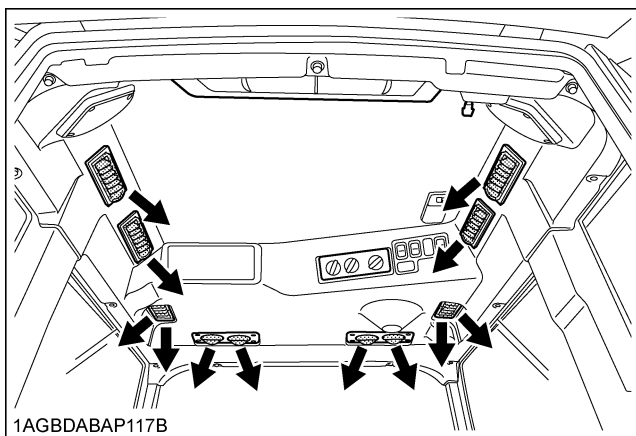

◆ **Foot warming and head cooling**

1. Set the mode switch to the  position.
2. In the cooling or dehumidifying-heating mode, set the temperature control dial at the center position area.
3. Open the front air outlet and the door air outlet direct it to your feet.
4. You can feel your head cool and your feet warm.

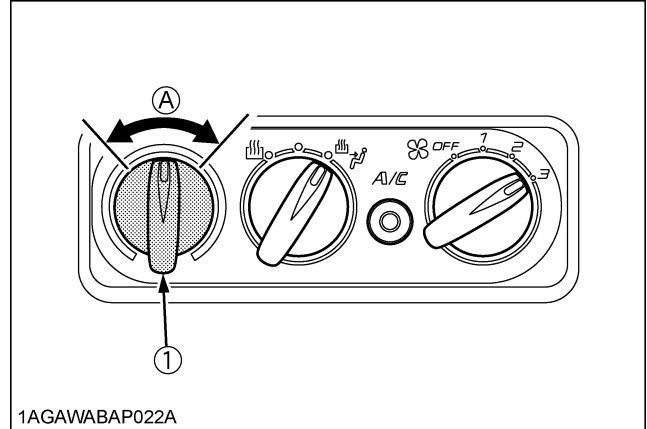

(1) Temperature control dial (A) Center position area

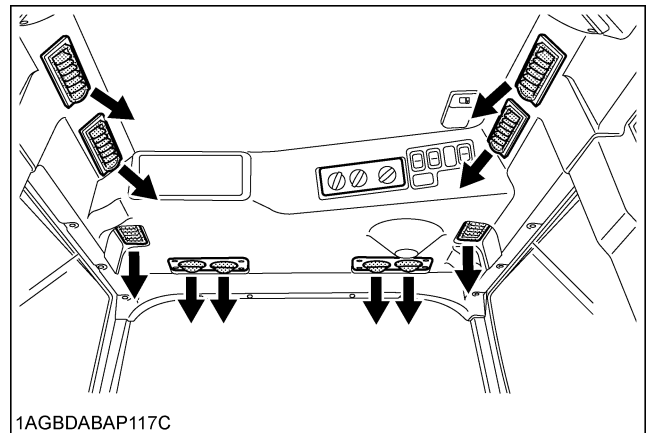

◆ **Defrosting or demisting**

To defrost or demist the windshield, take the following steps.

1. Set the mode switch to the  position.
2. Open the front air outlet and direct it to the windshield.
3. Set the recirculation / fresh air selection lever to the "FRESH AIR" position.
4. Set the blower switch and the temperature control dial to the "3" and max "WARM" (end of clockwise) positions, respectively.

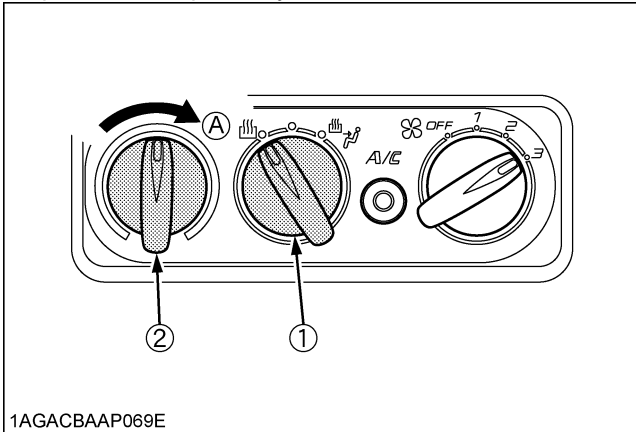

1AGACBAAP069E

- (1) Mode switch (A) "WARM"
 (2) Temperature control dial

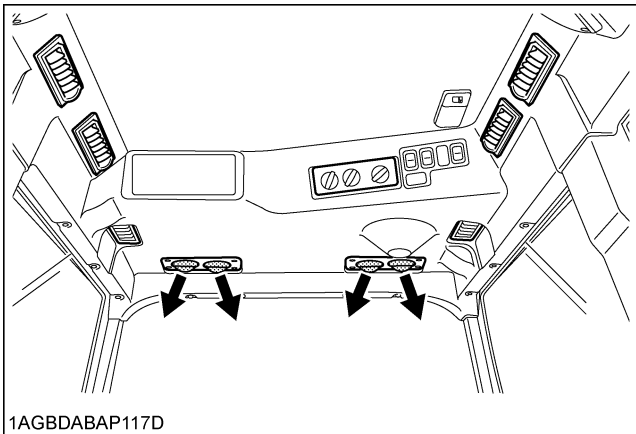

1AGBDABAP117D

REAR / SIDE DEFOGGER WITH TIMER (if equipped)

To activate the rear / side window defoggers, press the switch marked  while the key switch is in the "ON" position. Then, the yellow light on the switch turns on. After about 15 minutes, the defoggers automatically turn off as well as the yellow light. To turn the defogger off, press the switch once more.

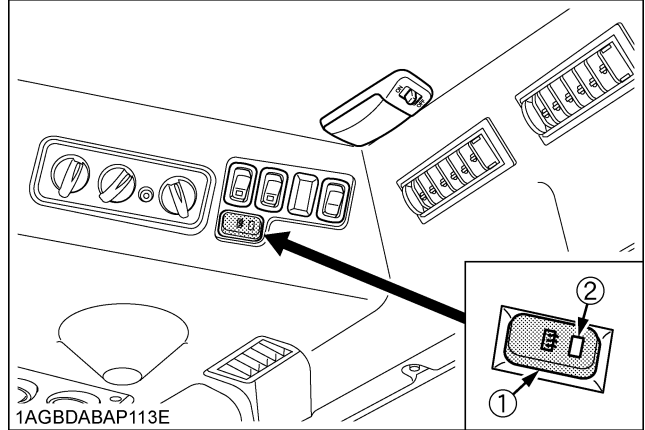

1AGBDABAP113E

- (1) Defogger switch
 (2) Yellow light

IMPORTANT :

- The battery will discharge if the defogger and the key switch remain in the "ON" or "ACC" positions with the engine stopped. Always use the defogger with the engine running.

INSTALLING THE IMPLEMENT CONTROL BOX

1. Make an opening in each of the corner plugs. Introduce the implement control cable and hydraulic hose through these openings into the CAB.

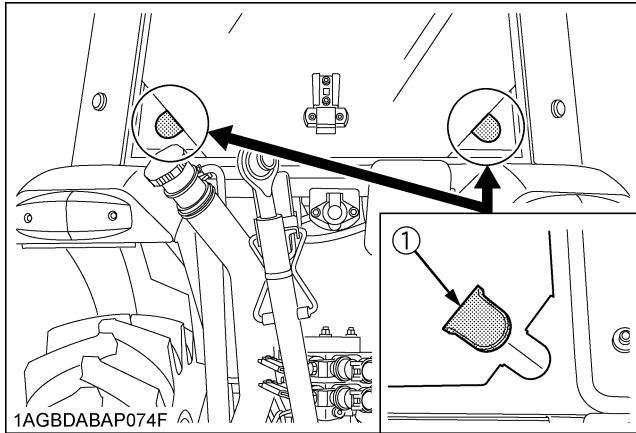

(1) Corner plug

NOTE :

- Before removing the corner plug, cut the two spots of the weather strip above the corner plug with a knife.
- Do not remove the weather strip of the corner plug to prevent rainwater intrusion into the CAB.

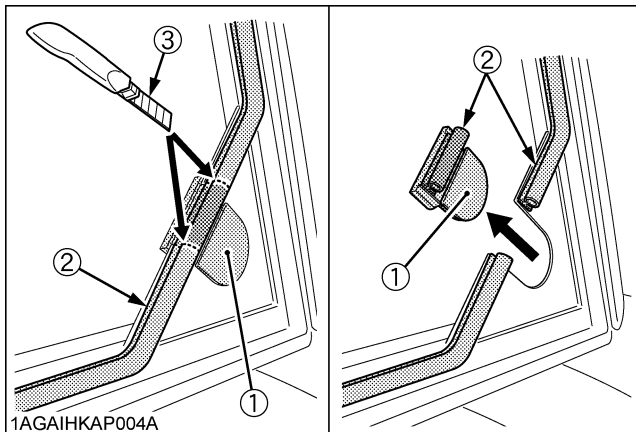

- (1) Corner plug
- (2) Weather strip (rubber)
- (3) Knife

ELECTRICAL OUTLET

■ Electrical Outlet

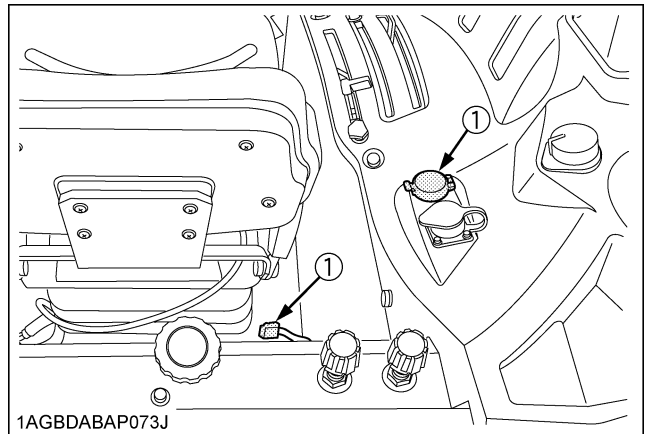

(1) Accessory electrical outlet (15A)

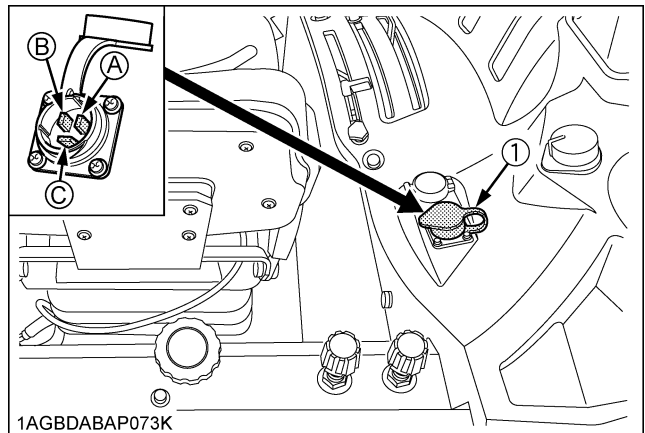

- (1) Accessory electrical outlet
- (A) Terminal: Through the ACC position of the key switch (5 A)
- (B) Terminal: Through the battery direct (30A)
- (C) Terminal: Ground

MAINTENANCE

SERVICE INTERVALS

	Interval	Items	Ref. page		
A	initial 50 Hr	Engine oil	Change	101	
		Engine oil filter	Replace	101	
B	every 50 Hr	Engine start system	Check	101	
		Wheel bolt torque	Check	102	
		Tie-rod dust cover	Check	102	*2
C	every 100 Hr	Greasing	---	102	
		Air cleaner Primary element	Clean	103	*1
		Fan belt	Adjust	104	
		Brake pedal	Adjust	105	
		Parking brake	Check	106	*2
		Battery condition	Check	106	*7
		Air conditioner drive belt	Adjust	108	
D	every 200 Hr	Toe-in	Adjust	109	
		Fuel tank water	Drain	110	
		Inner air filter	Clean	110	
		Fresh air filter	Clean	110	
E	every 400 Hr	Water separator	Clean	111	
		Fuel solenoid pump	Clean	112	
F	every 500 Hr	Engine oil	Change	112	
		Engine oil filter	Replace	113	
		Fuel filter	Replace	114	
		Hydraulic oil filter	Replace	114	
		Lift cylinder hose	Check	119	*6
		Power steering oil line	Check	115	*6
		Radiator hose and clamp	Check	116	*6
		Fuel line	Check	117	*6
		Intake air line	Check	118	*6
		Brake hose	Check	119	*2
Air conditioner pipes and hoses	Check	119	*6		
G	every 600 Hr	Front axle pivot	Adjust	119	

	Interval	Items	Ref. page		
H	every 1000Hr	Transmission fluid	Change	120	
		Front differential case oil	Change	120	
		Front axle gear case oil	Change	120	
		Engine valve clearance	Adjust	121	*2
I	every 1000Hr or 1 year *3	Air cleaner Primary element	Replace	121	
		Air cleaner Secondary element	Replace	121	
		Exhaust manifold	Check	121	*2
J	every 1500Hr	Fuel injector nozzle tip	Clean	121	*2 @
		DEF/AdBlue® injector tip	Clean	121	*2
		DEF/AdBlue® line	Check	121	*2
		Oil separator element	Replace	121	*2 @
		PCV (Positive crankcase ventilation) valve (oil separator)	Check	122	*2 @
		EGR cooler	Check Clean	122	*2 @
K	every 2000Hr or 2 years *4	Cooling system	Flush	122	
		Coolant	Change	123	
L	every 3000Hr	Turbo charger	Check	124	*2 @
		Supply pump	Check	124	*2
		Intake air heater	Check	124	*2
		EGR system	Check Clean	124	*2 @
		DPF muffler	Clean	124	*2 @
		DEF/AdBlue® injector	Check	124	*2
		DEF/AdBlue® pump filter	Replace	125	

	Interval	Items		Ref. page		
M	every 1 year	Antifrost Heater for Oil Separator (if equipped)	Check	125	*2	
		CAB isolation cushion	Check	125		
		DPF differential pressure sensor pipe	Check	125	*2	
		EGR pipe	Check	125	*2	
N	every 2 years	Oil separator hose	Replace		*2	
		Boost sensor hose	Replace	125	*2	
		DPF differential pressure sensor hose	Replace	125	*2	
		EGR cooler hose	Replace	125	*2	
		Master cylinder filter	Clean	125	*2	@
O	every 3 years	Parking brake cable	Replace	125	*2	
P	every 4 years	Radiator hose and clamp	Replace	126		
		Fuel line	Replace	126	*2	
		Intake air line	Replace	126	*2	
		Power steering oil line	Replace	126	*2	
		Lift cylinder hose	Replace	126	*2	
		Master cylinder kit	Replace	126	*2	
		Brake seal 1 and 2	Replace	126	*2	
		Brake hose	Replace	126	*2	
		Equalizer kit	Replace	126	*2	
Air conditioner pipes and hoses	Replace	126	*2			
Q	Service as required	Fuel system	Bleed	126		
		Brake system	Bleed	127		
		Clutch housing water	Drain	127		
		Fuse	Replace	128		
		Light bulb	Replace	131		
		Lubricating point	---	132		
		Washer liquid	Add	132		
		Refrigerant (gas)	Check	132		

- *1 Air cleaner should be cleaned more often in dusty conditions than in normal conditions.
 - *2 Consult your local KUBOTA Dealer for this service.
 - *3 Every 1000 hours or every 1 year, whichever comes first.
 - *4 Every 2000 hours or every 2 years, whichever comes first.
 - *5 The initial 50 hours should not be a replacement cycle.
 - *6 Replace if any deterioration (crack, hardening, scar, or deformation) or damage occurred.
 - *7 When the battery is used for less than 100 hours per year, check the battery condition by reading the indicator annually.
- The items listed above (@ marked) are registered as emission related critical parts by KUBOTA in the U.S.EPA nonroad emission regulation. As the engine owner, you are responsible for the performance of the required maintenance on the engine according to the above instruction. Please see the Warranty Statement in detail.

LUBRICANTS, FUEL AND COOLANT

No.	Locations	Capacities			Lubricants		
		M4N-071	M5N-091	M5N-111			
1	Fuel	76 L (20.1 U.S.gals.)			No.2-D S15 diesel fuel No.1-D S15 diesel fuel if temperature is below -10 °C (14 °F)		
2	DEF/AdBlue®	---	12.3 L (3.2 U.S.gals.)				
3	Coolant	10 L (11 U.S.qts.) (Recovery tank: 1.0L (1.1 U.S.qts.))			Fresh clean soft water with anti-freeze		
4	Washer liquid	2 L (2.1 U.S.qts.)			Automobile washer liquid		
5	Engine crankcase (with filter)	10.7 L (11.3 U.S.qts.)			• Engine oil: API Service Classification	CJ-4 [DPF type engine]	
					Above 25 °C (77 °F)		SAE30, SAE10W-30 or 15W-40
					-10 to 25 °C (14 to 77 °F)		SAE10W-30 or 15W-40
					Below -10 °C (14 °F)		SAE10W-30
6	Transmission case	52 L (54.9 U.S.qts.)			• KUBOTA SUPER UDT2 fluid*		
7	Front differential case oil [4WD]	5 L (5.3 U.S.qts.)			• KUBOTA SUPER UDT2 fluid* or SAE 80 - SAE 90 gear oil		
8	Front axle gear case oil [4WD]	3 L (3.2 U.S.qts.)					
9	Greasing	No. of greasing points			Capacity	Type of grease	
	Top link	2			Until grease overflows.	Multipurpose Grease NLGI-2 OR NLGI-1(GC-LB)	
	Top link bracket	2					
	Lift rod	2					
	Hydraulic lift cylinder pin	4					
	Front axle gear case support [4WD]	2					
	Front axle support	2					
	Steering joint shaft	1					
	Battery terminal	2			A small amount		

NOTE :

The product name of KUBOTA genuine UDT fluid may be different from that in the Operator's Manual depending on countries or territories. Consult your local KUBOTA Dealer for further details.

NOTE :**◆ Engine Oil:**

- Oil used in the engine should have an American Petroleum Institute (API) service classification and Proper SAE Engine Oil according to the ambient temperatures as shown above:
- Refer to the following table for the suitable API classification engine oil according to the engine type (with DPF (Diesel Particulate Filter) type engines) and the fuel.

Fuel used	Engine oil classification (API classification)
	Oil class for engines with DPF
Ultra Low Sulfur Fuel [<0.0015% (15 ppm)]	CJ-4

◆ Fuel:

- Use the ultra low sulfur diesel fuel only [below 0.0015% (15 ppm)] for these engines.
- Cetane number of 45 minimum. Cetane number greater than 50 is preferred, especially for temperatures below -20°C (-4 °F) or elevations above 1500 m (5000 ft).
- Diesel fuels specified to EN 590 or ASTM D975 are recommended.
- No.2-D is a distillate fuel of lower volatility for engines in industrial and heavy mobile service. (SAE J313 JUN87)

◆ DEF/AdBlue®:

The DEF/AdBlue®, used as reducing agent of SCR, is a 32.5% urea aqueous solution.

The product is available at gas stations, truck stops and specialty shops. Be sure to use the genuine product only.

- Use exclusively DEF/AdBlue® that complies with the requirements of ISO 22241-1.

◆ Transmission Oil:

*KUBOTA Super UDT-2: For an enhanced ownership experience, we highly recommend Super UDT-2 to be used instead of standard hydraulic/transmission fluid.

Super UDT-2 is a proprietary KUBOTA formulation that delivers superior performance and protection in all operating conditions.

Regular UDT is also permitted for use in this machine.

- Indicated capacities of water and oil are manufacturer's estimate.
-

PERIODIC SERVICE



WARNING

To avoid personal injury or death:

- Do not work under any hydraulically supported devices. They can settle, suddenly leak down, or be accidentally lowered. If necessary to work under tractor or any machine elements for servicing or adjustment, securely support them with stands or suitable blocking beforehand.

HOW TO OPEN THE HOOD



WARNING

To avoid personal injury or death from contact with moving parts;

- Never open the hood while the engine is running.
- Do not touch muffler or exhaust pipes while they are hot; Severe burns could result.
- Hold the hood with other hand while unlocking release lever.

■ Hood

To open the hood, hold the hood and pull the release lever and open the hood.

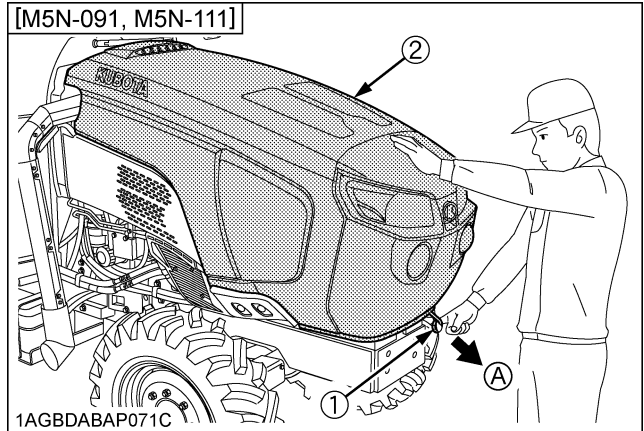
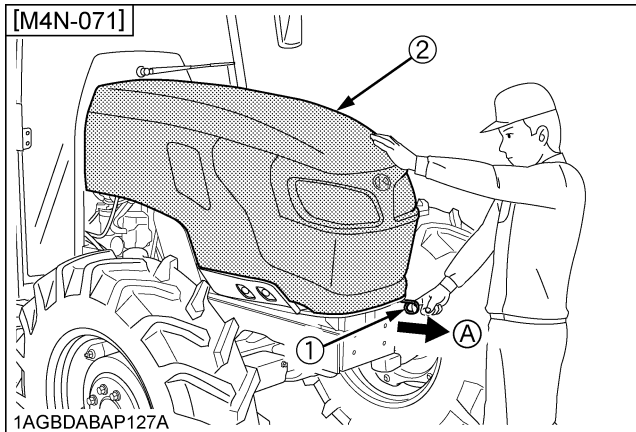

(1) Release lever
(2) Hood

(A) "PULL"

NOTE :

- To close the hood, push the hood into position using both hands.

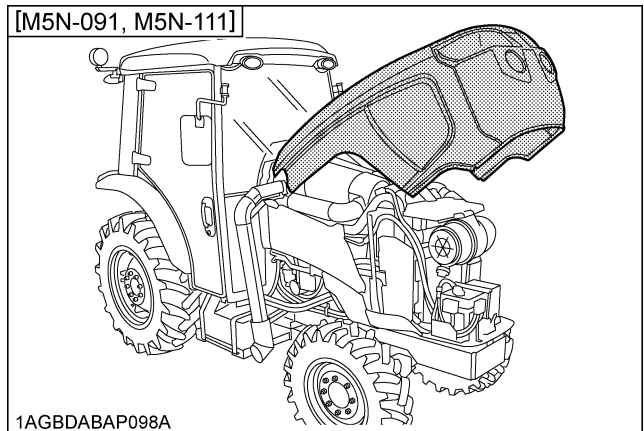
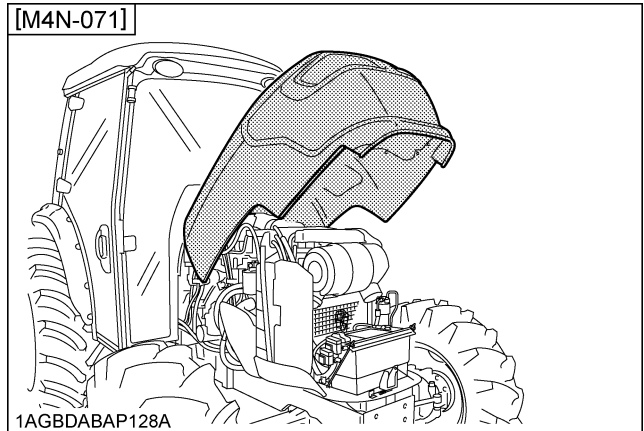

Side Cover

[M5N-091, M5N-111]

1. Remove the bolts (2).
Move the side cover 1 forward, and pull out the cover from pins.
2. Loosen the bolt (5), and remove the side cover 2.

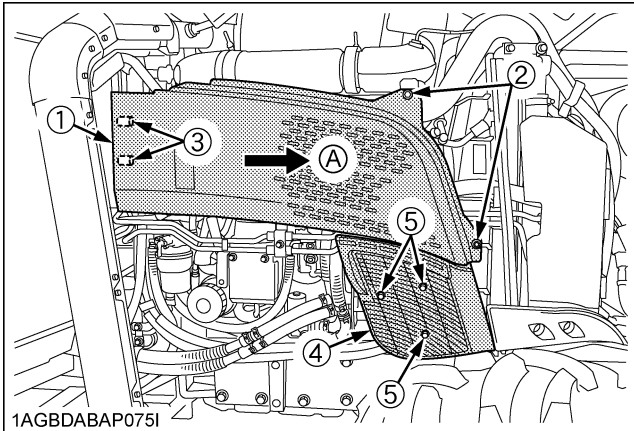

- (1) Side cover 1 (A) "MOVE"
 (2) Bolt
 (3) Pin
 (4) Side cover 2
 (5) Bolt

[M4N-071]

Remove the bolts as shown below.

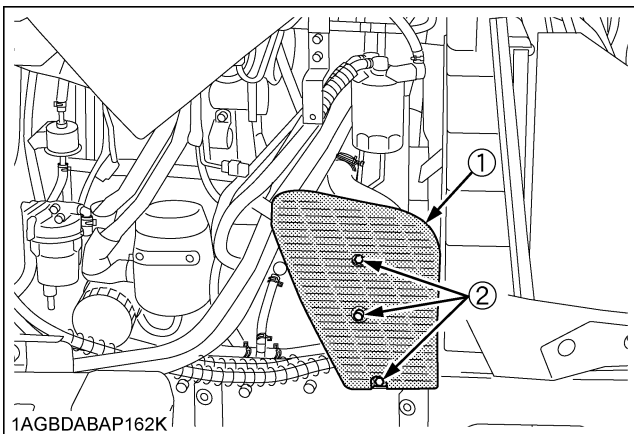

- (1) Side cover
 (2) Bolt

DAILY CHECK

For your own safety and maximum service life of the machine, make a thorough daily inspection before operating the machine to start the engine.



WARNING

To avoid personal injury or death:
 Take the following precautions when checking the tractor.

- Park the machine on firm and level ground.
- Set the parking brake.
- Lower the implement to the ground.
- All residual pressure of the hydraulic system released.
- Stop the engine and remove the key.

Walk Around Inspection

Look around and under the tractor for such items as loose bolts, trash build-up, oil or coolant leaks, broken or worn parts.

Checking and Refueling



WARNING

To avoid personal injury or death:
 ● Do not smoke while refueling.
 ● Be sure to stop the engine before refueling.

1. Check the amount of fuel by fuel gauge.
2. When the fuel warning indicator lights up, it is time to add fuel.

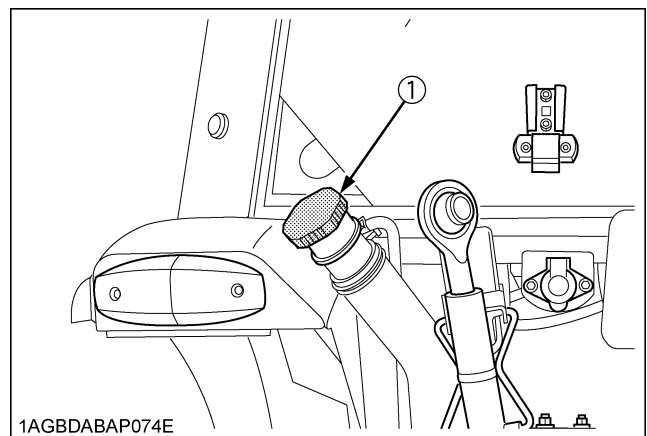

(1) Fuel tank cap

Fuel tank capacity	76 L (20.1 U.S.gals.)
--------------------	-----------------------

IMPORTANT :

- Be sure to use Ultra Low Sulfur Fuel (S15).
- Do not permit dirt or trash to get into the fuel system.
- Be careful not to let the fuel tank become empty, otherwise air will enter the fuel system, necessitating bleeding before next engine start.
- If the engine runs out of fuel and stalls, the engine components may be damaged.
- Be careful not to spill during refueling. If a spill should occur, wipe it off at once, or it may cause a fire.
- To prevent condensation (water) accumulation in the fuel tank, fill the tank before parking overnight.

■Checking the DEF/AdBlue® level and adding the fluid

[M5N-091, M5N-111]



WARNING

To avoid personal injury or death:

- Before adding DEF/AdBlue®, stop the engine. When adding the fluid, preferably wear protective goggles and rubber gloves.

Look at the DEF/AdBlue® gauge on the instrument panel to see how much fluid remains. If the level is too low, add DEF/AdBlue® as required.

Before removing the DEF/AdBlue® cap, clean dirt away from the caps and the tank openings.

If the fluid runs short or poor-quality fluid is added, a warning sign appears on the instrument panel. If this warning is ignored and the operation continues, the engine output will be limited.

(For details, refer to "Warning Indication and its Countermeasure" in "SELECTIVE CATALYTIC REDUCTION (SCR) MUFFLER" in "OPERATING THE ENGINE" section.)

The DEF/AdBlue® tank cap is blue. Be careful not to confuse it with the fuel tank cap.

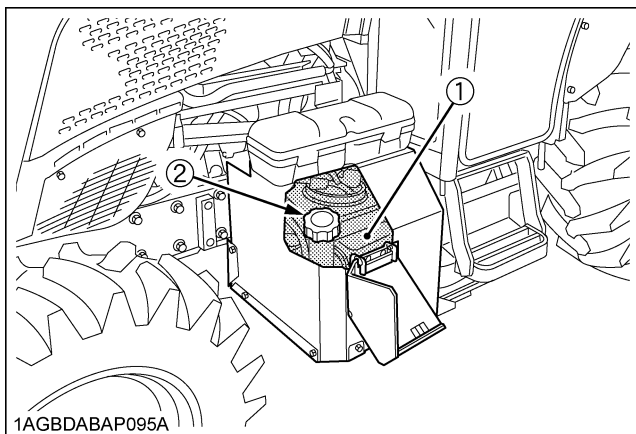

(1) DEF/AdBlue® tank
(2) Tank cap (Blue)

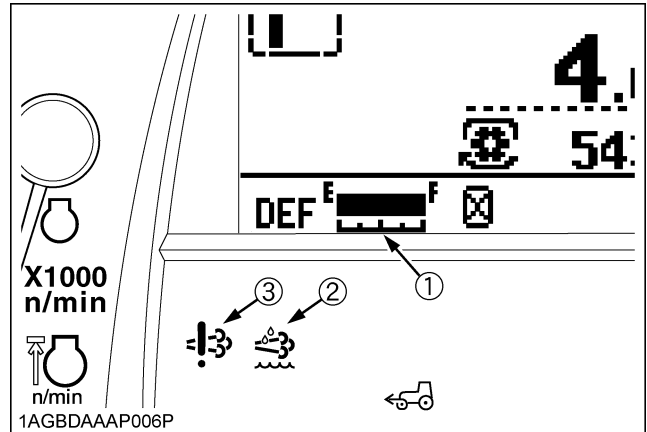

(1) DEF/AdBlue® gauge
(2) DEF/AdBlue® warning indicator
(3) DEF/AdBlue® system warning indicator

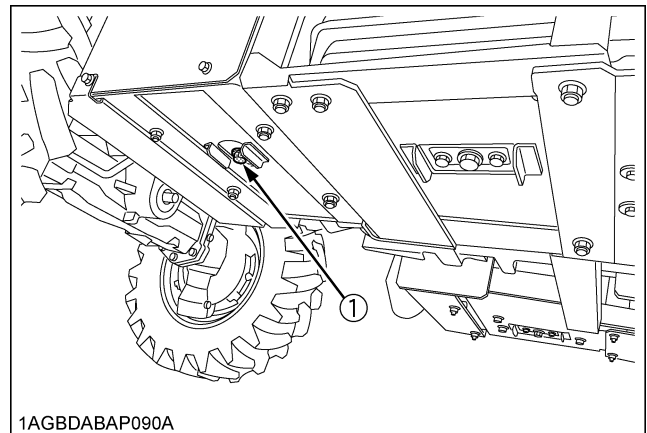

(1) Drain plug

Tank capacity	12.3 L (3.2 U.S.gals.)
---------------	------------------------

IMPORTANT :

- Use exclusively DEF/AdBlue® that complies with the requirements of ISO 22241-1.
- Do not allow fuel, oil or the like to enter the DEF/AdBlue® tank.
If any other substance (gasoline/diesel/oil) is mistakenly introduced into the DEF/AdBlue® tank, do not attempt to start the engine and contact your local KUBOTA dealer as soon as possible.
- Check the DEF/AdBlue® gauge regularly to avoid emptying its tank.
- If the DEF/AdBlue® spills, wipe it with water. If spills are not wiped, metal areas will rust and the aluminum areas will corrode.
- Be careful not to overfill the DEF/AdBlue® tank because otherwise a small amount of DEF/AdBlue® might flow out of the breather. Pour DEF/AdBlue® until its level rises up to the filler port. And the air will be let out of the tank and the liquid level will drop below the filler port. But do not attempt to pour any more.

■ Checking Water Separator

1. When the water has collected upper limit in the water separator, the water separator indicator on the instrument panel lights up and warning buzzer sounding.

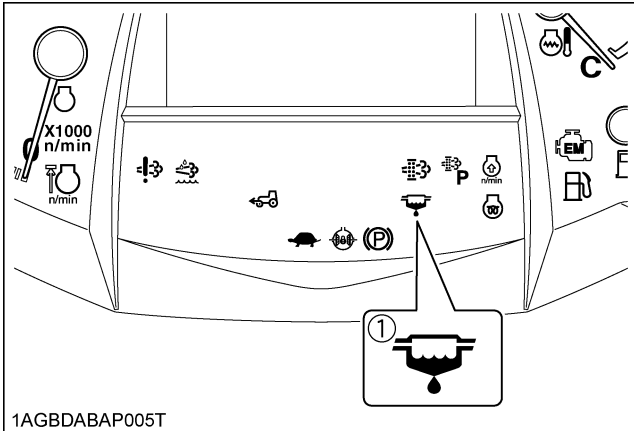

(1) Water separator indicator

2. In such case, close the fuel shutoff-valve and loosen the air plug and drain plug by several turns.
3. Allow water to drain. When no more water comes out and fuel starts to flow out, retighten the air plug and drain plug.
4. Bleed the fuel system.
(See "SERVICE AS REQUIRED" in "PERIODIC SERVICE" section.)

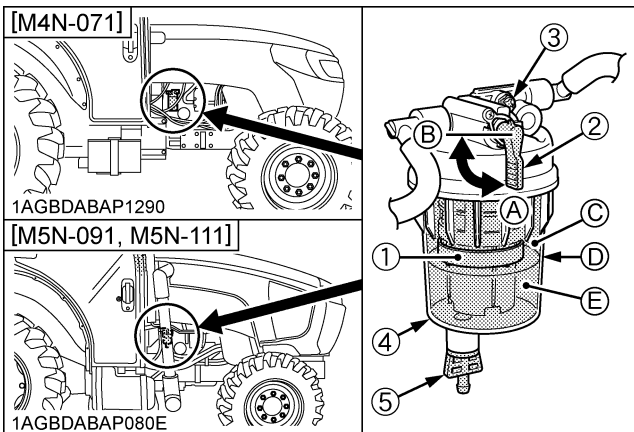

- | | |
|------------------------|-------------------|
| (1) Red float | (A) "ON" |
| (2) Fuel shutoff-valve | (B) "OFF" |
| (3) Air plug | (C) "FUEL" |
| (4) Cup | (D) "UPPER LIMIT" |
| (5) Drain plug | (E) "WATER" |

NOTE :

- When the red float reaches near the upper limit level, start from step 2 in the above procedure to drain water in the water separator.

IMPORTANT :

- If water is drawn through to the fuel pump, extensive damage will occur.

■ Checking Engine Oil Level



WARNING

To avoid personal injury or death:

- Be sure to stop the engine before checking the oil level.

1. Park the machine on a flat surface.
2. Check engine oil before starting the engine or 5 minutes or more after the engine has stopped.
3. To check the oil level, draw out the dipstick, wipe it clean, replace it, and draw it out again. Check to see that the oil level lies between the 2 notches.
If the level is too low, add new oil to the prescribed level at the oil inlet.
(See "LUBRICANTS, FUEL AND COOLANT" in "MAINTENANCE" section.)

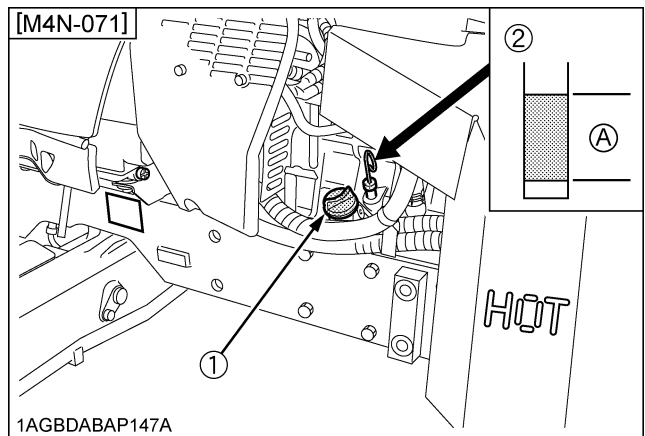

1AGBDABAP147A

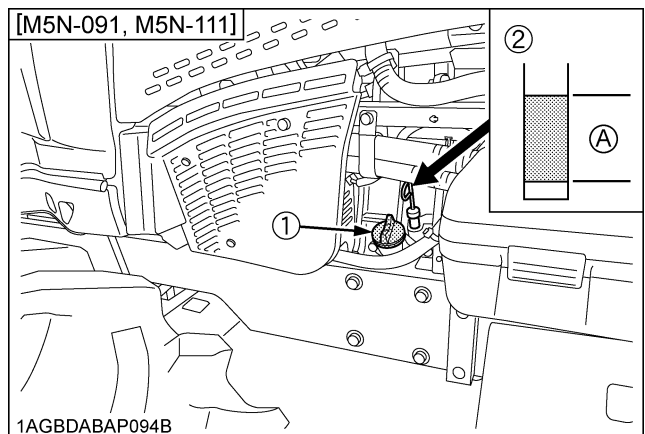

1AGBDABAP094B

- (1) Oil inlet (A) Oil level is acceptable within this range.
(2) Dipstick

IMPORTANT :

- When using an oil of different maker or viscosity from the previous one, remove all of the old oil. Never mix two different types of oil.
- If oil level is low, do not run engine.

NOTE :

- At times a small amount of fuel, which is used to regenerate the DPF, may get mixed with the engine oil and the engine oil may increase in volume.

■Checking Transmission Fluid Level

1. Park the machine on a flat surface, lower the implement and shut off engine.
2. To check the oil level, draw out the dipstick, wipe it clean, replace it, and draw it out again. Check to see that the oil level lies between the 2 notches. If the level is too low, add new oil to the prescribed level at the oil inlet.
(See "LUBRICANTS, FUEL AND COOLANT" in "MAINTENANCE" section.)

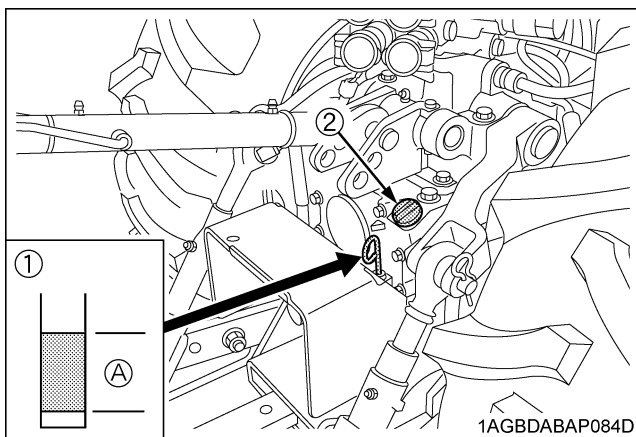

(1) Dipstick (A) Oil level is acceptable within this range.
(2) Oil inlet

IMPORTANT :

- If oil level is low, do not run engine.

■Checking Coolant Level

! WARNING

To avoid personal injury or death:

- Do not remove radiator cap while coolant is hot. When cool, slowly rotate cap to the first stop and allow sufficient time for excess pressure to escape before removing the cap completely.

1. Check to see that the coolant level is between the "FULL" and "LOW" marks of recovery tank.
2. When the coolant level drops due to evaporation, add soft water only up to the full level.
In case of leakage, add anti-freeze and soft water in the specified mixing ratio up to the full level.
(See "Flushing Cooling System and Changing Coolant" in "EVERY 2000 HOURS or 2 YEARS" in "PERIODIC SERVICE" section.)
3. When the coolant level is lower than "LOW" mark of recovery tank, remove the radiator cap and check to see that the coolant level is just below the port. If level is low, add coolant.

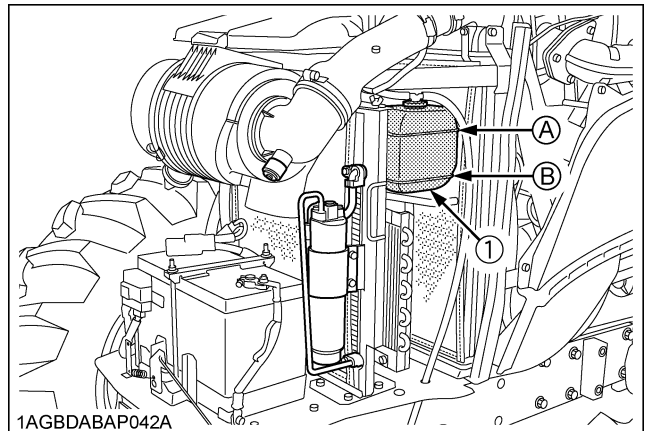

(1) Recovery tank (A) "FULL"
(B) "LOW"

IMPORTANT :

- If the radiator cap has to be removed, follow the caution above and securely retighten the cap.
- Use clean, fresh soft water and anti-freeze to fill the radiator.
- If coolant should leak, consult your local KUBOTA Dealer.

■ Cleaning Evacuator Valve

Open the evacuator valve to get rid of large particles of dust and dirt.

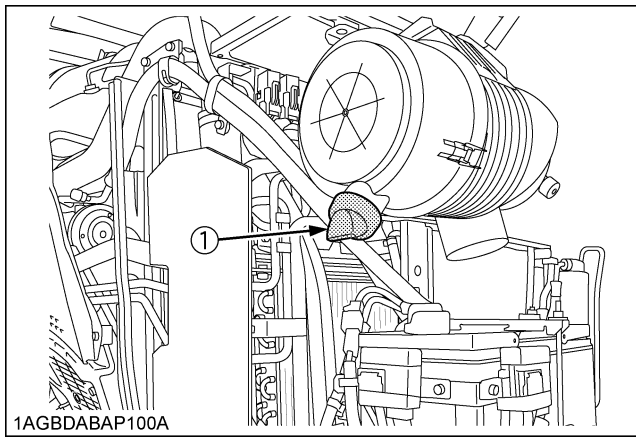

(1) Evacuator valve

■ Checking Dust Indicator

There is a dust indicator on the air cleaner body. If the red signal on the dust indicator is visible, clean the element immediately. (See "Cleaning Air Cleaner Primary Element" in "EVERY 100 HOURS" in "PERIODIC SERVICE" section.) Reset the red signal by pushing a "RESET" button after cleaning.

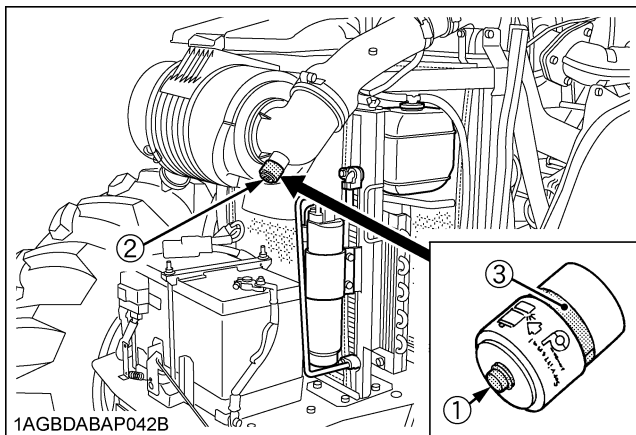

(1) "RESET" button
 (2) Dust indicator
 (3) Red signal

■ Cleaning Grill, Radiator and Cooler

⚠ WARNING

To avoid personal injury or death:

- Be sure to stop the engine before removing the screen.
- The condenser and receiver become hot while the air conditioner is running. Before checking or cleaning them, wait long enough until they cool down.

◆ Detaching the panel

1. Pull the upper part of the panel outward.
2. Raise the panel until pin (A) clears the hole, and take out the panel.
3. Attaching the panel is performed vice versa.

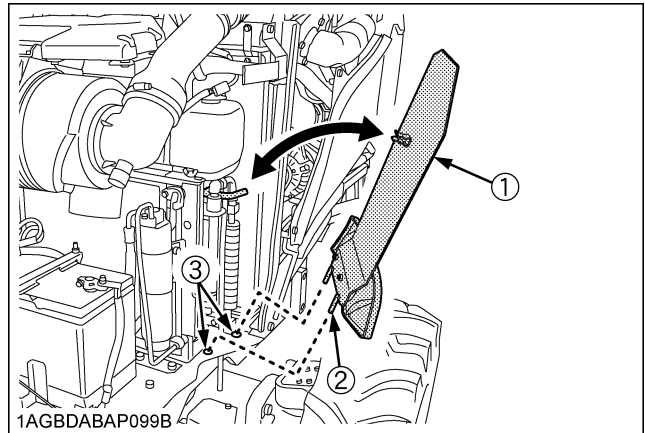

(1) Panel
 (2) Pin (A)
 (3) Hole

◆ **Sliding the air conditioner condenser**

1. Loosen the wing nut.
2. Hold the handle, slide the air conditioner condenser assembly toward yourself.

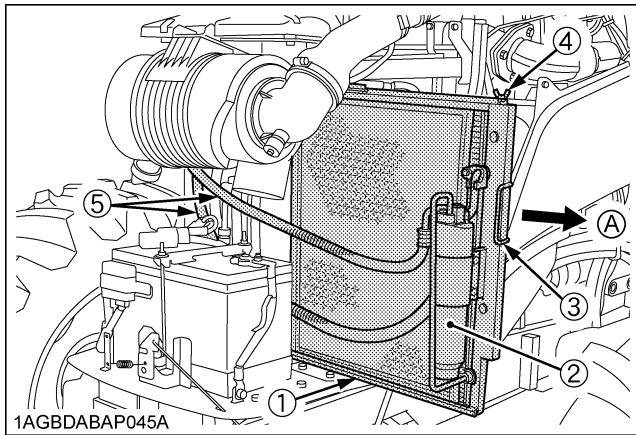

- (1) Condenser
 (2) Receiver
 (3) Handle
 (4) Wing nut
 (5) Air conditioner hose

(A) "PULL"

IMPORTANT :

- Do not hold the air conditioner receiver or the air conditioner pipes when sliding out the condenser for cleaning.

◆ **Cleaning**

1. Check front grill to be sure it is clean from debris.
2. Detach the radiator and air conditioner screens and remove all foreign materials.
3. Check radiator, intercooler, oil cooler, fuel cooler, air conditioner condenser and battery mount to be sure they are clean from debris.

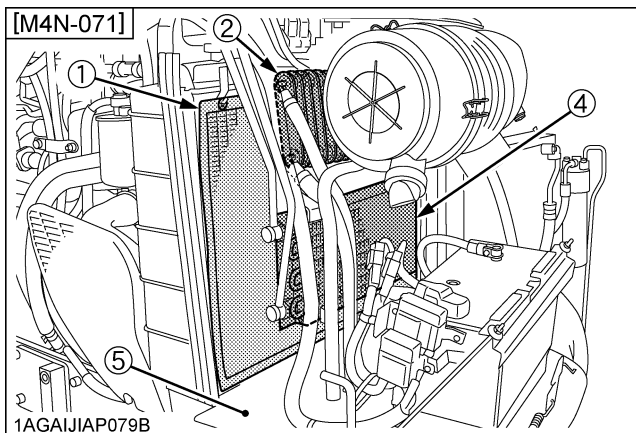

1AGAIJIAP079B

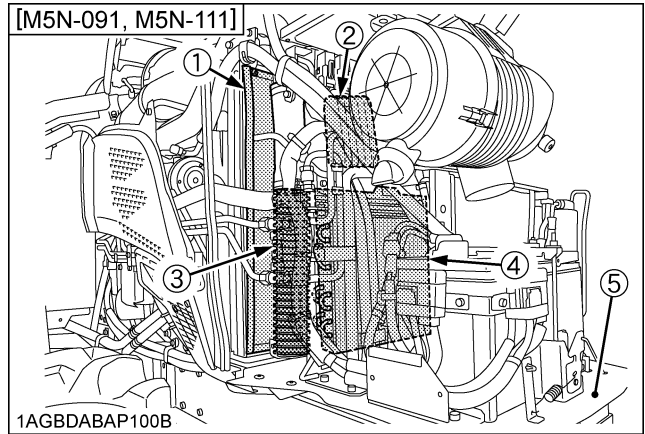

- (1) Radiator screen
 (2) Fuel cooler
 (3) Intercooler
 (4) Oil cooler
 (5) Battery mount

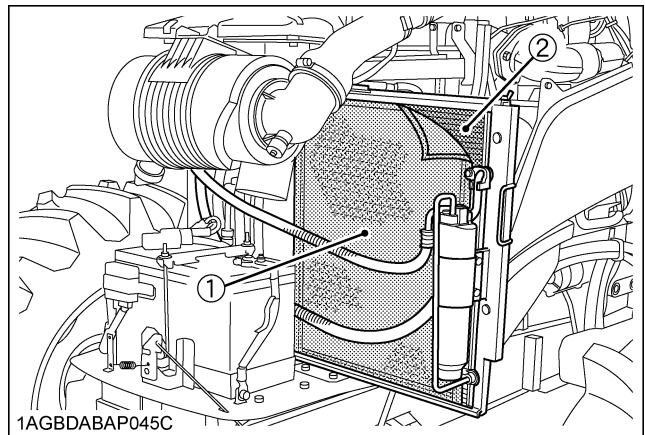

- (1) Air conditioner condenser screen
 (2) Air conditioner condenser

■ Checking DPF/SCR Muffler



WARNING

To avoid personal injury or death:

- Before checking or cleaning the DPF/SCR muffler, stop the engine and wait long enough until it is cooled down.

Check the DPF/SCR muffler and its surroundings for accumulation of anything flammable. Otherwise a fire may result.

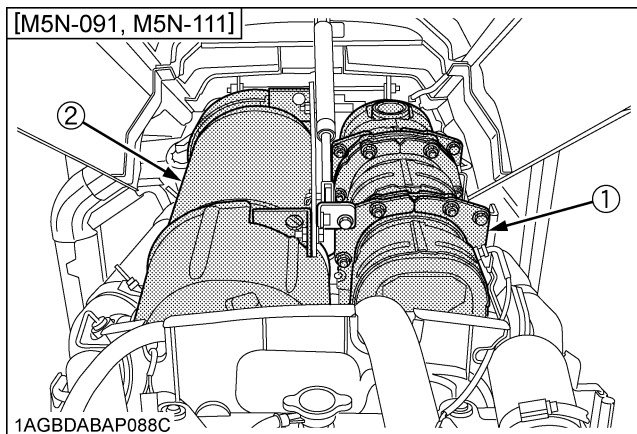
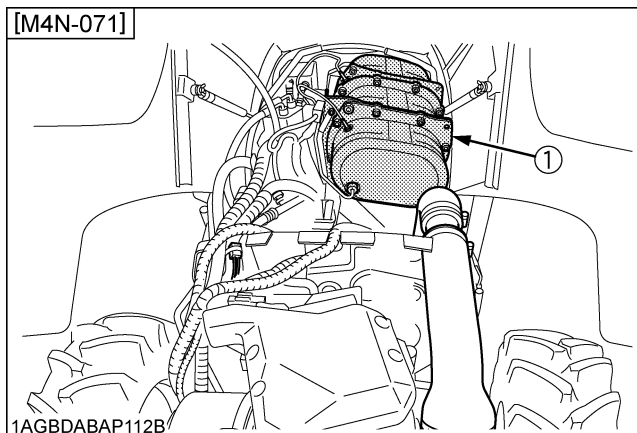

- (1) DPF muffler
(2) SCR muffler

■ Checking Brake Pedal



WARNING

To avoid personal injury or death:

- Be sure brake pedals have equal adjustment when using locked together. Incorrect or unequal brake pedal adjustment can cause the tractor to swerve or roll-over.

1. Inspect the brake pedals for free travel, and smooth operation.
2. Adjust if incorrect measurement is found: (See "Adjusting Brake Pedal" in "EVERY 100 HOURS" in "PERIODIC SERVICE" section.)

■ Checking Gauges, Meter and Easy Checker(TM)

1. Inspect the instrument panel for broken gauge(s), meter(s) and Easy Checker(TM) lamps.
2. Replace if broken.

■ Checking Head Light, Turn Signal / Hazard Light etc.

1. Inspect the lights for broken bulbs and lenses.
2. Replace if broken.

■ Checking Seat Belt

1. Always check condition of seat belt attaching hardware before operating tractor.
2. Replace if damaged.

■ Checking Movable Parts

If any of the movable parts, such as levers and pedals, is not smoothly moved because of rust or sticky material, do not attempt to force it into motion.

In the above case, remove the rust or the sticky material, and apply oil or grease on the relevant spot.

Otherwise, the machine may get damaged.

INITIAL 50 HOURS

With a new machine, be sure to do the servicing, as discussed below, after the first 50 operating hours.

■ Changing Engine Oil

(See "Changing Engine Oil" in "EVERY 500 HOURS" in "PERIODIC SERVICE" section for this service.)

■ Replacing Engine Filter

(See "Replacing Engine Oil Filter" in "EVERY 500 HOURS" in "PERIODIC SERVICE" section for this service.)

EVERY 50 HOURS

■ Checking Engine Start System



WARNING

To avoid personal injury or death:

- Do not allow anyone near the tractor while testing.
- If the tractor does not pass the test, do not operate the tractor.

◆ Preparation before testing.

1. Place all control levers in the "NEUTRAL" position.
2. Set the parking brake and stop the engine.

◆ Test: Switch for the shuttle shift lever.

1. Follow the instruction of "PARKING THE TRACTOR". (See "PARKING THE TRACTOR" in "SAFE OPERATION" section.)
2. Sit on the operator's seat.
3. Shift the shuttle shift lever to the forward or reverse position.
4. Depress the clutch pedal fully.
5. Disengage the PTO clutch control switch or lever.
6. Turn the key to "START" position.
7. The engine must not crank.
8. If it cranks, consult your local KUBOTA Dealer for this service.

◆ Test: Switch for the PTO clutch control switch or lever.

1. Follow the instruction of "PARKING THE TRACTOR". (See "PARKING THE TRACTOR" in "SAFE OPERATION" section.)
2. Sit on the operator's seat.
3. Engage the PTO clutch control switch or lever.
4. Depress the clutch pedal fully.
5. Shift the shuttle shift lever to the neutral position.
6. Turn the key to "START" position.
7. The engine must not crank.
8. If it cranks, consult your local KUBOTA Dealer for this service.

◆ Test: Checking Operator Presence Control (O.P.C.) System.

1. Follow the instruction of "PARKING THE TRACTOR". (See "PARKING THE TRACTOR" in "SAFE OPERATION" section.)
2. Make sure the PTO drive shaft is disconnected from the tractor.
3. Sit on the operator's seat.
4. Start the engine.
5. Engage the PTO gear shift lever. (if equipped)
6. Engage the PTO clutch control switch or lever. The PTO should begin to rotate. Disengage the PTO clutch control switch or lever.
7. While lifting yourself from the seat, engage the PTO clutch control switch or lever.
 - (1) The PTO should begin to rotate and a buzzer should sound.
 - (2) Disengage the PTO clutch control switch or lever.
 - (3) If the buzzer does not sound, shut off the engine and consult your local KUBOTA Dealer for immediate servicing of the PTO OPC.
8. If the PTO OPC is operating properly, shut off the engine, and reconnect the implement drive shaft to the PTO. Restart the engine per the available instructions.



WARNING

To avoid personal injury or death:

- Before checking the PTO OPC, make sure that the PTO drive shaft should be disconnected from the tractor.
- If the buzzer does not sound during the PTO OPC check procedure, shut off engine and consult your local KUBOTA Dealer for immediate servicing of the PTO OPC.
- The unit should not be operated until servicing is completed.

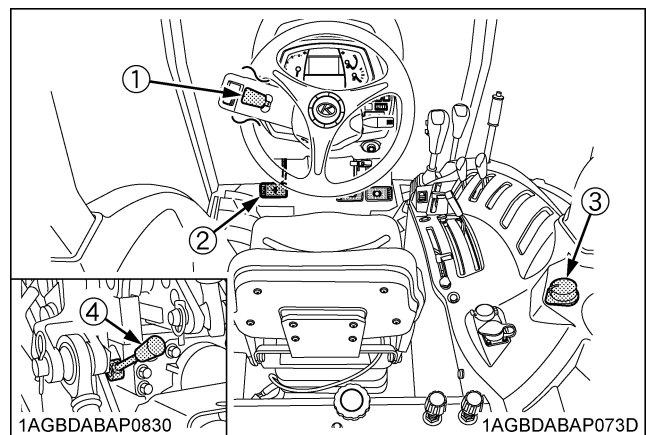

- (1) Shuttle shift lever
- (2) Clutch pedal
- (3) PTO clutch control switch
- (4) PTO gear shift lever

■ Checking Wheel Bolt Torque



WARNING

To avoid personal injury or death:

- Never operate tractor with a loose rim, wheel, or axle.
- Any time bolts and nuts are loosened, retighten to specified torque.
- Check all bolts and nuts frequently and keep them tight.

Check wheel bolts and nuts regularly especially when new. If they are loose, tighten them.

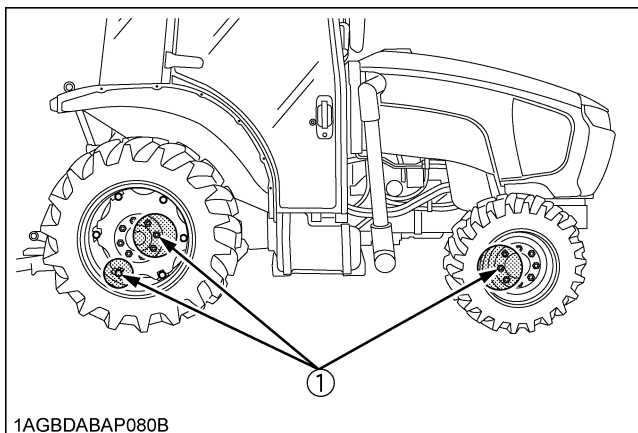

1AGBDABAP080B

(1) Wheel bolts

(See "WHEEL ADJUSTMENT" in "TIRES, WHEELS AND BALLAST" section.)

■ Checking Tie-rod Dust Cover

1. Check to see that dust covers are not damaged.
2. If dust covers are damaged, consult local KUBOTA Dealer for this service.

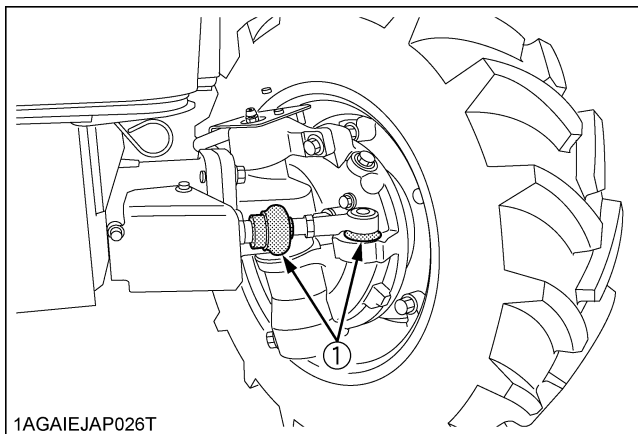

1AGAIEJAP026T

(1) Dust cover

IMPORTANT :

- If dust covers are cracked, water and dust invade into tie-rod and it will be early wear.

EVERY 100 HOURS

■ Lubricating Grease Fittings

Apply a small amount of multipurpose grease to the following points every 100 hours:

If you operated the machine in extremely wet and muddy conditions, lubricate grease fittings more often.

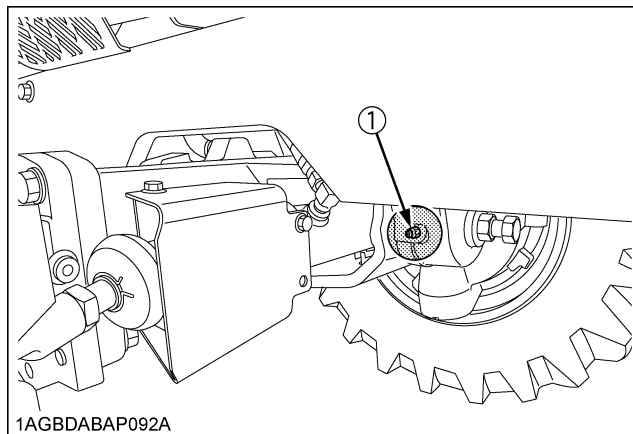

1AGBDABAP092A

(1) Grease fitting (Front axle support)

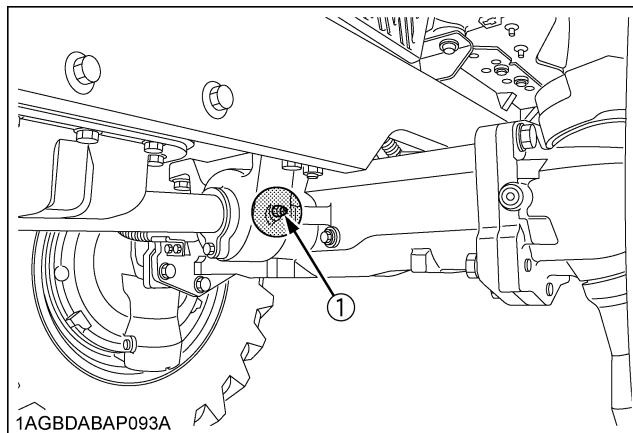

1AGBDABAP093A

(1) Grease fitting (Front axle support)

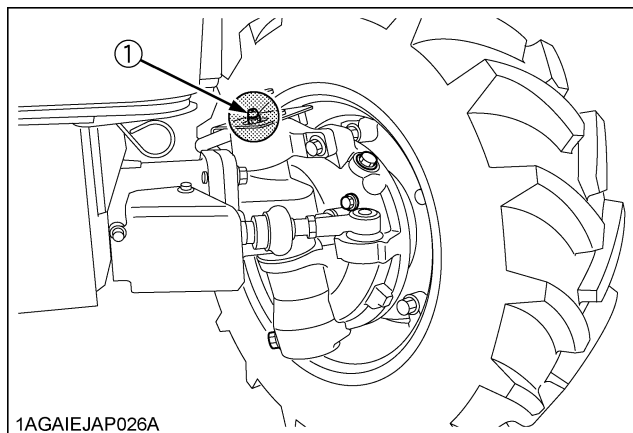

1AGAIEJAP026A

(1) Grease fitting (Front axle gear case support) [RH, LH]

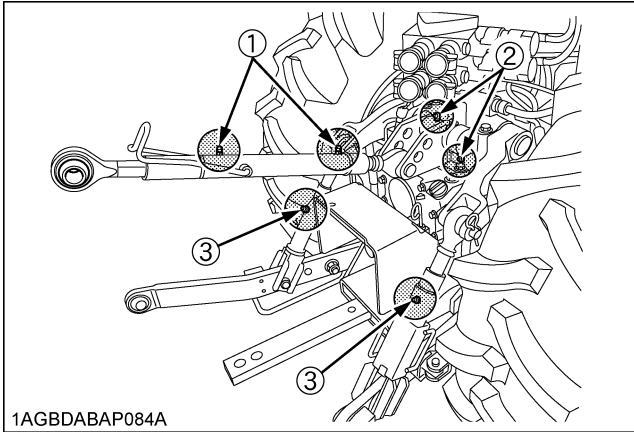

- (1) Grease fitting (Top link)
- (2) Grease fitting (Top link bracket)
- (3) Grease fitting (Lifting rod)

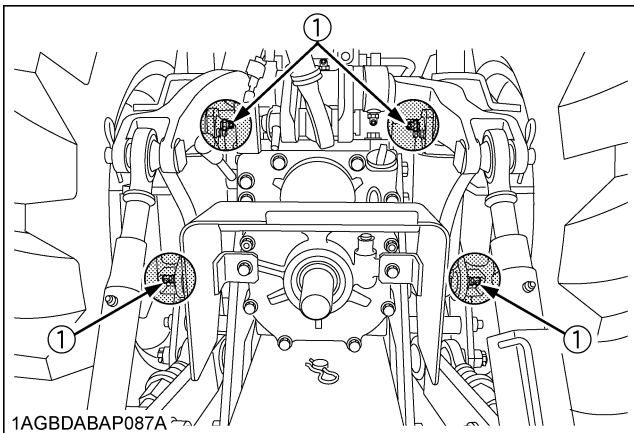

- (1) Grease fitting (Hydraulic lift cylinders pin)

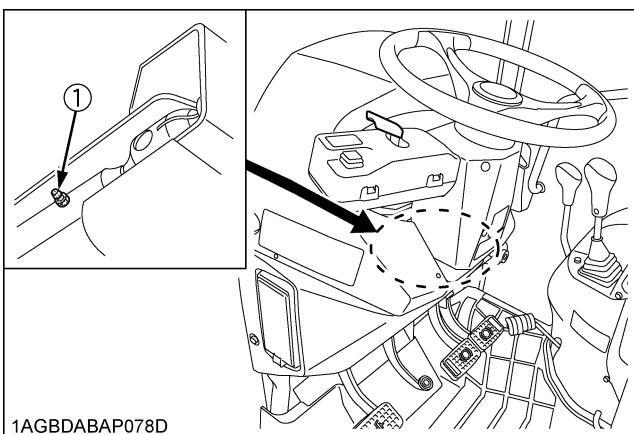

- (1) Grease fitting (Steering joint shaft)

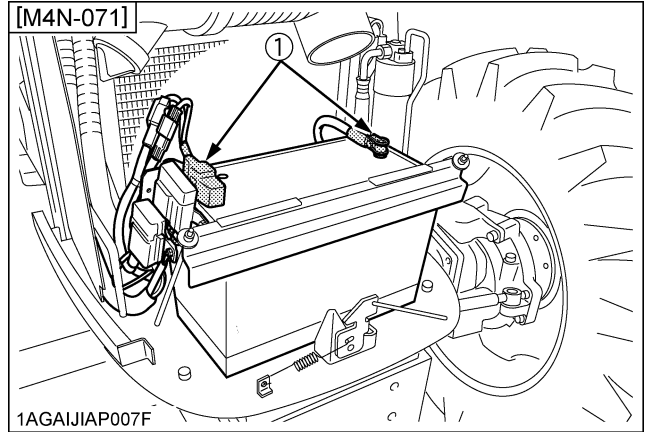

- (1) Battery terminals

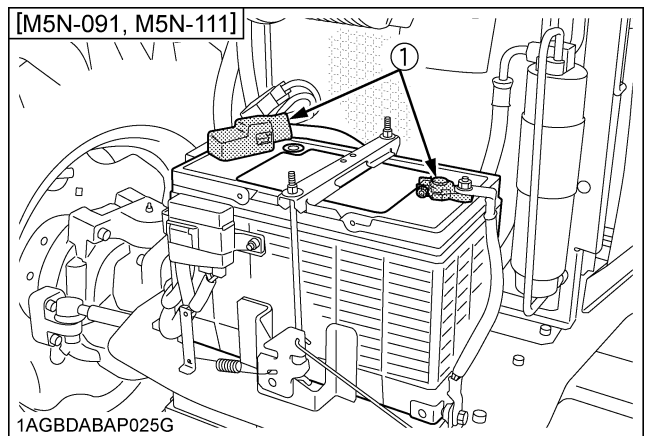

- (1) Battery terminals

■ Cleaning Air Cleaner Primary Element

NOTE :

- If the air conditioner condenser is pulled out when cleaning the air cleaner, the air cleaner cover can be detached and attached easily. (See "Cleaning Radiator Screen" in "DAILY CHECK" in "PERIODIC SERVICE" section.)

1. Remove the air cleaner cover and primary element.
2. Clean the primary element:
 - (1) When dry dust adheres to the element, blow compressed air from the inside, turning the element. Pressure of compressed air must be under 205 kPa (2.1 kgf/cm², 30 psi).
 - (2) When carbon or oil adheres to the element, soak the element in detergent for 15 minutes then wash it several times in water, rinse with clean water and dry it naturally. After element is fully dried, inspect inside of the element with a light and check if it is damaged or not.
3. Replace air cleaner primary element:
Once every 1000 hours or yearly, whichever comes first.

NOTE :

- Check to see if the evacuator valve is blocked with dust.

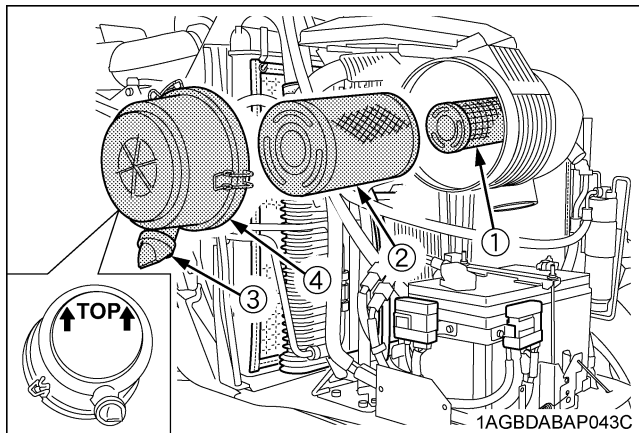

- (1) Secondary (safety) element
- (2) Primary element
- (3) Evacuator valve
- (4) Cover

IMPORTANT :

- The air cleaner uses a dry element, never apply oil.
- Do not run the engine with filter element removed.
- Be sure to refit the cover with the arrow **↑** (on the rear of cover) upright. If the cover is improperly fitted, evacuator valve will not function and dust will adhere to the element.
- Do not touch the secondary element except in cases where replacing is required. (See "Replacing Air Cleaner Secondary Element" in "EVERY 1000 HOURS or 1 YEAR" in "PERIODIC SERVICE" section.)

◆ **Evacuator Valve**

Open the evacuator valve once a week under ordinary conditions - or daily when used in a dusty place - to get rid of large particles of dust and dirt.

■ **Adjusting Fan Belt Tension**



WARNING

To avoid personal injury or death:

- Be sure to stop the engine before checking belt tension.

[M5N-091, M5N-111]

Proper fan belt tension	A deflection of between 13 to 15 mm (0.51 to 0.59 in.) when the belt is pressed in the middle of the span.
-------------------------	--

1. Stop the engine and remove the key.
2. Apply moderate thumb pressure to belt between pulleys.
3. If tension is incorrect, loosen the alternator mounting bolts and turn the adjusting bolt to adjust the belt tension within acceptable limits.
4. Replace fan belt if it is damaged.

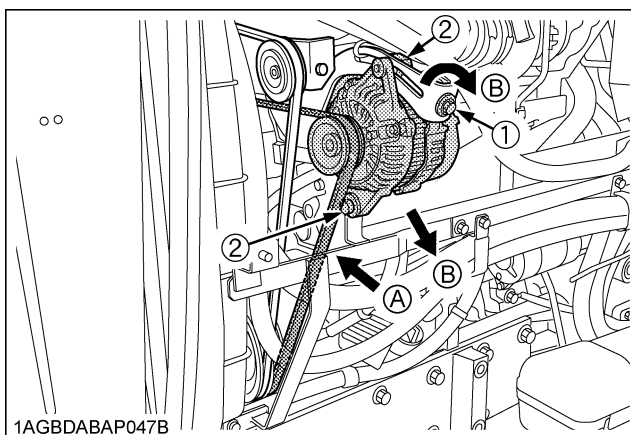

- (1) Adjusting bolt
- (2) Alternator mounting bolt
- (A) Check the belt tension
- (B) To tighten

[M4N-071]

Proper fan belt tension	A deflection of between 10 to 12 mm (0.39 to 0.47 in.) when the belt is pressed in the middle of the span.
-------------------------	--

1. Stop the engine and remove the key.
2. Apply moderate thumb pressure to belt between pulleys.
3. If tension is incorrect, loosen the tension pulley mounting nut and turn the adjusting bolt to adjust the belt tension within acceptable limits.
4. Replace fan belt if it is damaged.

IMPORTANT :

- Make sure that the V-belt tension is as specified as shown in the table above after tightening the tension pulley mounting nut.

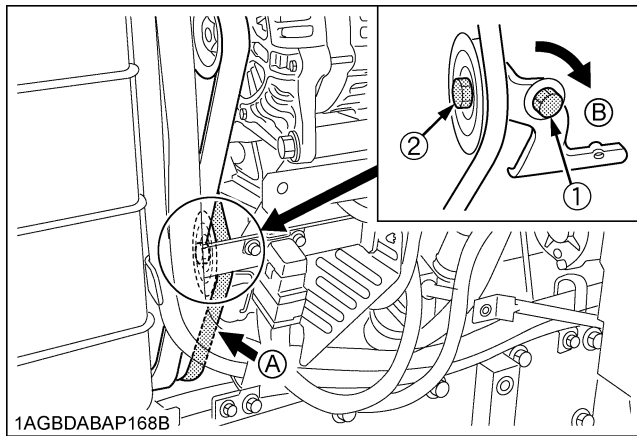

(1) Adjusting bolt (A) Check the belt tension
 (2) Tension pulley mounting nut (B) To tighten

■ Adjusting Brake Pedal

WARNING

To avoid personal injury or death:

- Stop the engine and chock the wheels before checking brake pedal.
- To prevent uneven braking, the specification must be within the recommended limit. If found out of the specifications, contact your local KUBOTA Dealer for adjusting the brakes.

◆ Checking the brake pedal free travel

Proper brake pedal free travel	7 to 14 mm (0.3 to 0.6 in.) on the pedal
	Keep the free travel in the right and left brake pedals equal.

1. Set the parking brake.
2. Slightly depress the brake pedals and measure free travel at the top of pedal stroke.

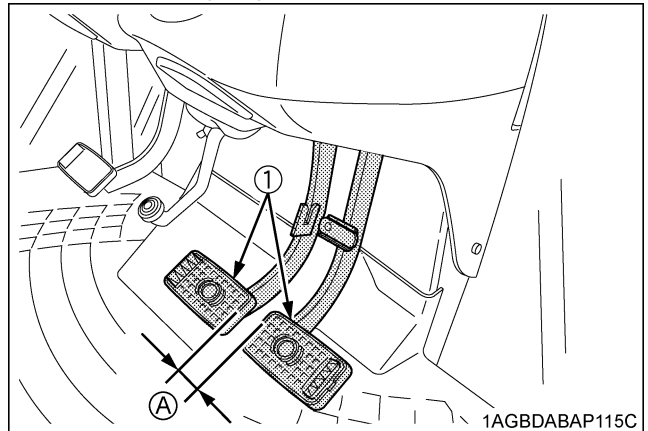

(1) Brake pedals (A) "FREE TRAVEL"

NOTE :

- Brake pedals should be equal when depressed.

◆ Checking the brake pedal stroke

Pedal stroke	Less than 100 mm (3.9 in.) at each pedal
--------------	--

1. Disengage the brake pedal lock.
2. Depress the brake pedal several times.
3. Step on the right-hand pedal and measure the level difference (pedal stroke) between this pedal and the left-hand pedal.
4. Do the same for the left-hand pedal.

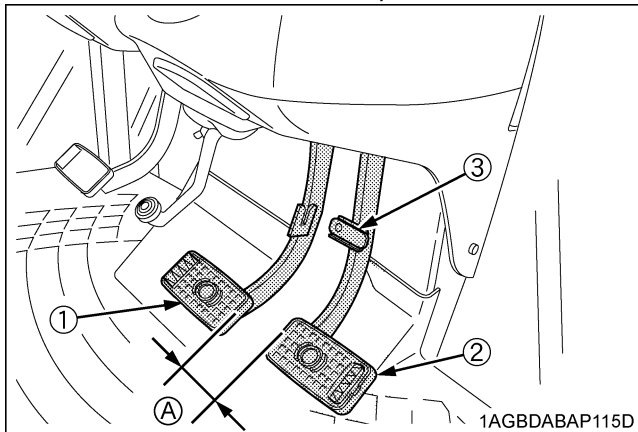

- (1) Brake pedal (LH) (A) "PEDAL STROKE"
 (2) Brake pedal (RH)
 (3) Brake pedal lock

◆ Checking the equalizer working level (anti-imbalance device)

1. Gently step on both brake pedals at once.
2. Further step on the right-hand pedal (the left-hand pedal slightly raises itself) and measure the level difference between the pedals.
3. Do the same for the left-hand pedal.

Equalizer working level	Level difference of over 5 mm (0.2 in.) between both pedals
-------------------------	---

■ Checking Gear Locked Parking Brake



WARNING

To avoid personal injury or death:

- Do not dismount the tractor while checking the parking brake.

Confirm the tractor (tractor unit only) can surely be parked on the slope of about 15 degrees (Slope that rises by 2.7 meters every 10 meters).

If the tractor moves, consult your local KUBOTA Dealer. Always engage the parking brake before dismounting the tractor.

■ Checking Battery Condition



DANGER

To avoid the possibility of battery explosion:

For the refillable type battery, follow the instructions below.

- Do not use or charge the refillable type battery if the fluid level is below the LOWER (lower limit level) mark. Otherwise, the battery component parts may prematurely deteriorate, which may shorten the battery's service life or cause an explosion. Check the fluid level regularly and add distilled water as required so that the fluid level is between the UPPER and LOWER levels.



WARNING

To avoid personal injury or death:

- Never remove the battery cap while the engine is running.
- Keep electrolyte away from eyes, hands and clothes. If you are splattered with it, wash it away completely with water immediately and get medical attention.
- Keep open sparks and flames away from the battery at all times. Hydrogen gas mixed with oxygen becomes very explosive.
- Wear eye protection and rubber gloves when working around battery.

The factory-installed battery is of non-refillable type. If the indicator turns white, do not charge the battery but replace it with new one.

Mishandling the battery shortens the service life and adds to maintenance costs.

The original battery is maintenance free, but needs some servicing.

If the battery is weak, the engine will be difficult to start and the lights will be dim. It is important to check the battery periodically.

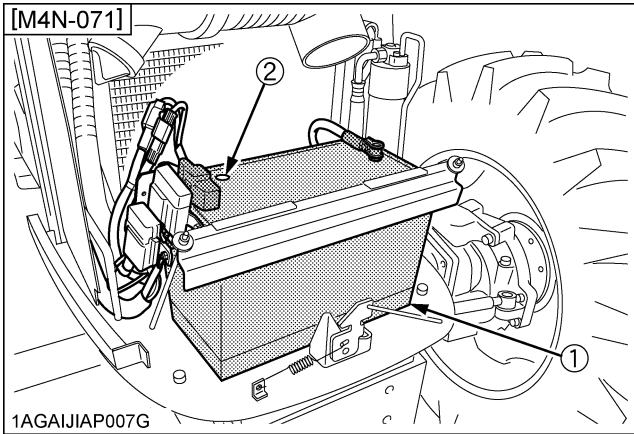

(1) Battery
(2) Indicator

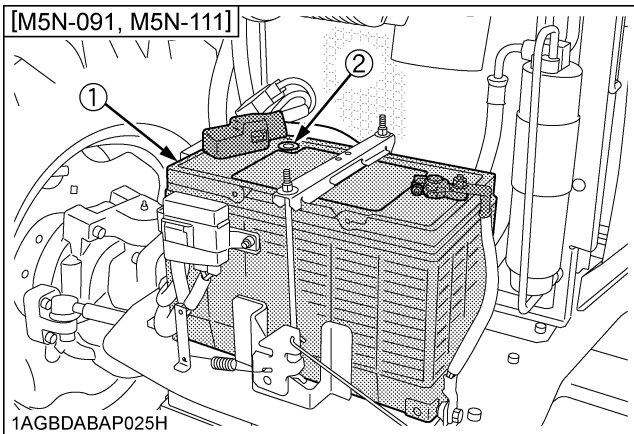

(1) Battery
(2) Indicator

◆ **How to read the indicator**

Check the battery condition by reading the indicator.

State of indicator display	
Green	Specific gravity of electrolyte and quality of electrolyte are both in good condition.
Black	Needs charging battery.
White	Needs replacing battery.

NOTE :

- When see the indicator, check from directly above by removing the air cleaner cover or using a mirror.

◆ **Battery Charging**

! WARNING

To avoid personal injury or death:

- When the battery is being activated, hydrogen and oxygen gases in the battery are extremely explosive. Keep open sparks and flames away from the battery at all times, especially when charging the battery.
- When charging the battery, ensure the vent caps are securely in place. (if equipped)
- When disconnecting the cable from the battery, start with the negative terminal first. When connecting the cable to the battery, start with the positive terminal first.
- Never check battery charge by placing a metal object across the posts. Use a voltmeter or hydrometer.

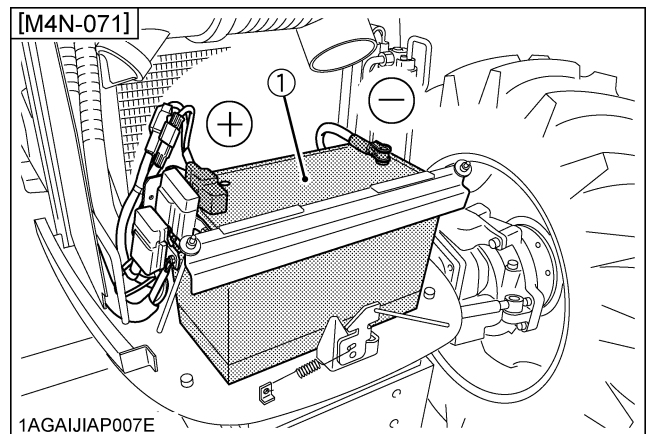

(1) Battery

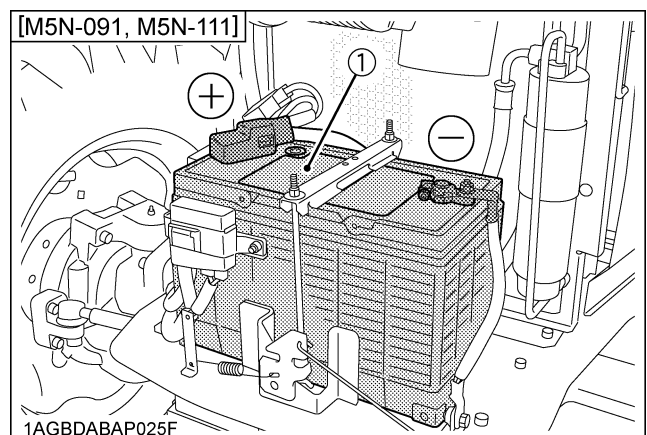

(1) Battery

1. To slow charge the battery, connect the battery positive terminal to the charger positive terminal and the negative to the negative, then recharge in the standard fashion.

2. A boost charge is only for emergencies. It will partially charge the battery at a high rate and in a short time. When using a boost-charged battery, it is necessary to recharge the battery as early as possible. Failure to do this will shorten the battery's service life.
3. The battery is charged if the indicator display turns green from black.
4. When exchanging an old battery for a new one, use battery of equal specification shown in **table 1**.

Table 1

Battery Type	Volts (V)	Capacity at 5H.R(A.H)
GP31(105E41R)	12	80

Reserve Capacity (min)	Cold Cranking Amps	Normal Charging Rate (A)
160	900	11

◆ Direction for Storage

1. When storing the tractor for long periods of time, remove the battery from tractor, adjust the electrolyte to the proper level and store in a dry place out of direct sunlight.
2. The battery self-discharges while it is stored. Recharge it once every 3 months in hot seasons and once every 6 months in cold seasons.

■ Adjusting Air-Conditioner Belt Tension



WARNING

To avoid personal injury or death:

- Be sure to stop the engine before checking belt tension.

Proper air-conditioner belt tension	A deflection of between 10 to 12 mm (0.4 to 0.48 in.) when the belt is pressed (98 N [10 kgf, 22.1 lbs.]) in the middle of the span.
-------------------------------------	--

1. Stop the engine and remove the key.
2. Apply moderate thumb pressure to belt between pulleys.
3. **[M4N-071]**
If tension is incorrect, loosen the double nuts and turn the adjusting bolt to adjust the belt tension within acceptable limits.
4. **[M5N-091, M5N-111]**
If tension is incorrect, loosen the tension pulley mounting nut and turn the adjusting bolt to adjust the belt tension within acceptable limits.
4. Replace air-conditioner belt if it is damaged.

IMPORTANT :

- Make sure that the V-belt tension is as specified as shown in the table above after tightening the tension pulley mounting nut.

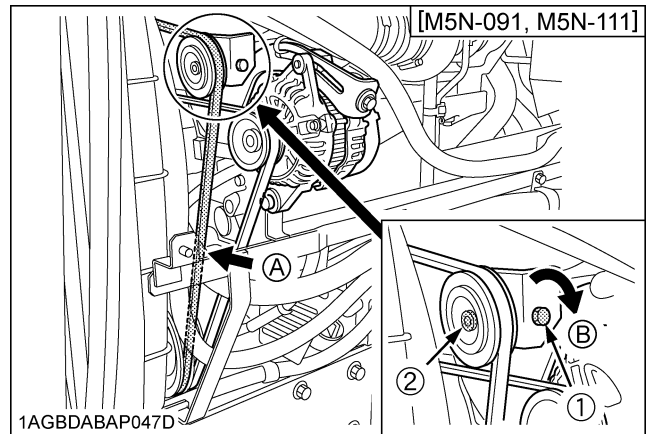
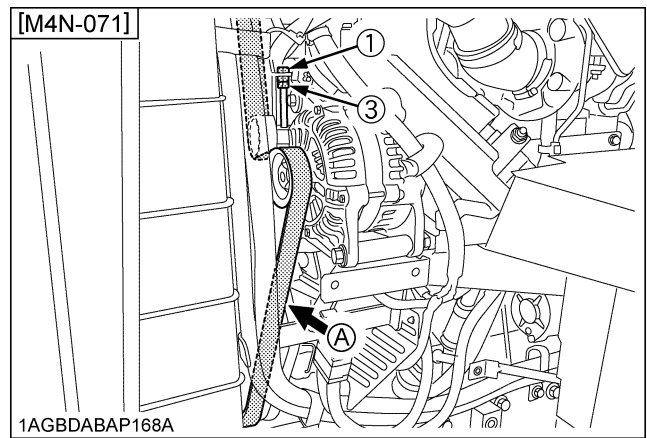

- (1) Adjusting bolt
- (2) Tension pulley mounting nut
- (3) Double nuts
- (A) Check the belt tension
- (B) To tighten

EVERY 200 HOURS

■ Adjusting Toe-in

Proper toe-in	2 to 8 mm (0.08 to 0.31 in.)
---------------	------------------------------

1. Park tractor on a flat place.
2. Turn steering wheel so front wheels are in the straight ahead position.
3. Lower the implement, lock the park brake and stop the engine.
4. Measure distance between tire beads at front of tire, at hub height.
5. Measure distance between tire beads at rear of tire, at hub height.
6. Front distance should be shorter than rear distance. If not, adjust tie rod length.

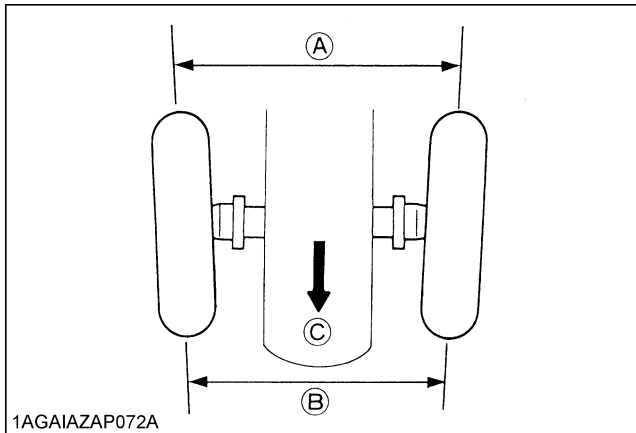

- (A) Wheel - to - wheel distance at rear
 (B) Wheel - to - wheel distance at front
 (C) "FRONT"

◆ Adjusting procedure [4WD]

1. Detach the snap ring.
2. Loosen the tie-rod nut.
3. Turn the tie-rod joint to adjust the rod length until the proper toe-in measurement is obtained.
4. Retighten the tie-rod nut.
5. Attach the snap ring of the tie-rod joint.

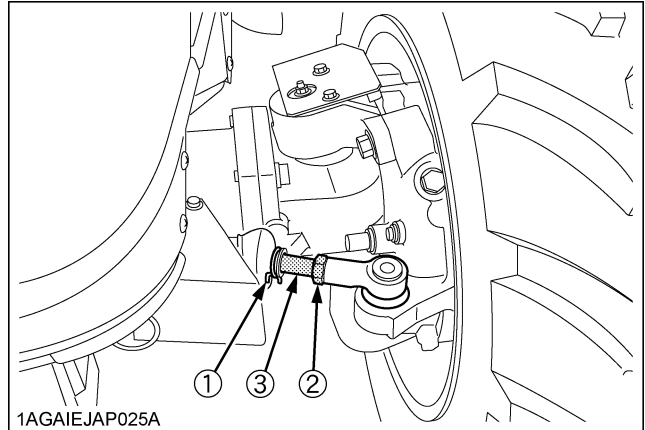

- (1) Snap ring
 (2) Tie-rod nut
 (167 to 196 N-m, 17 to 20 kgf-m, 123.2 to 144.6 ft-lbs)
 (3) Tie-rod joint

■ Draining Fuel Tank Water

Loosen the drain plugs at the bottom of the fuel tanks to let sediments, impurities and water out of the tanks. Finally tighten up the plugs.

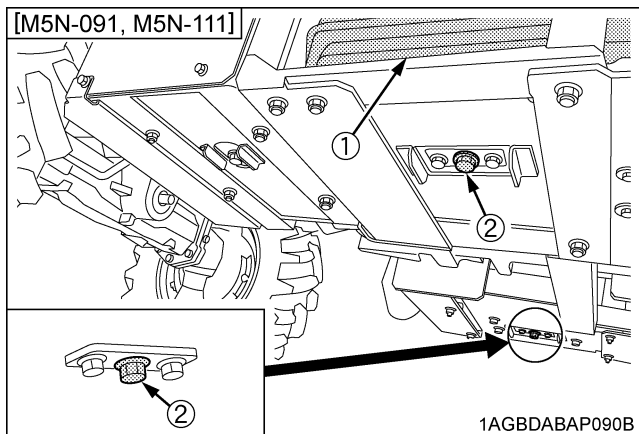
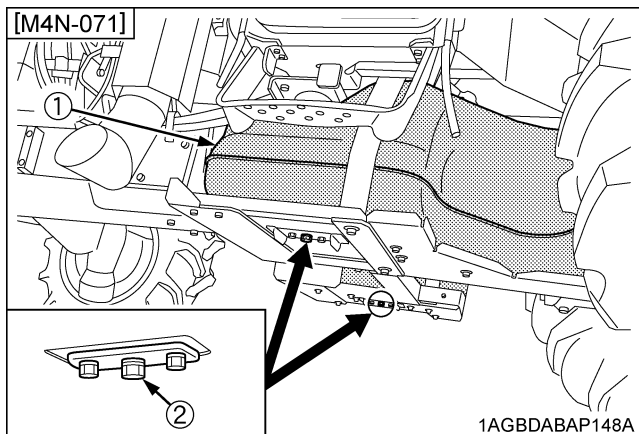

(1) Fuel Tank
(2) Drain plugs

IMPORTANT :

- If the fuel contains impurities, such as water, drain the fuel tank at shorter intervals.
- Drain the fuel tank before operating the tractor after a long period of storage.

■ Cleaning Inner Air Filter

Press the inner air filter in the arrow-marked directions to unlock it and remove the inner filter, and blow air from the direction opposite to the filter's normal air flow.

Pressure of compressed air must be under 205 kPa (2.1 kgf/cm², 30 psi).

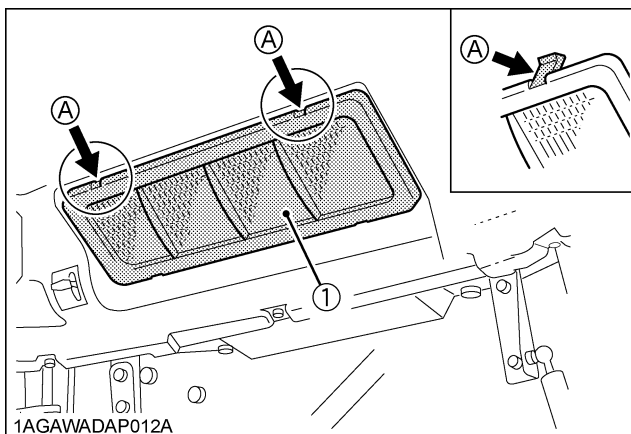

(1) Inner air filter (A) "PUSH"

■ Cleaning Fresh Air Filter

Remove the knob bolts and pull out filter.

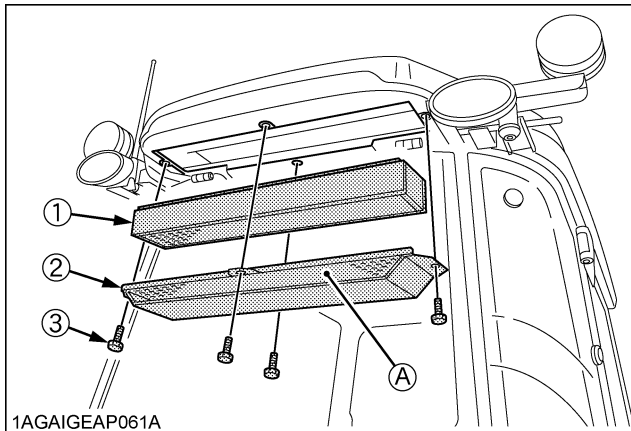

(1) Fresh air filter (2) Cover (3) Knob bolt (A) Air inlet port

NOTE :

- Attach the filter and cover as the illustration above.

◆ Cleaning the air filter

- Normal use
Blow air from the opposite direction to the filter's normal air flow.
Pressure of compressed air must be under 205 kPa (2.1 kgf/cm², 30 psi).

IMPORTANT :

- Do not hit the filter. If the filter becomes deformed, dust may enter into the air-conditioner, which may cause damage and malfunction.

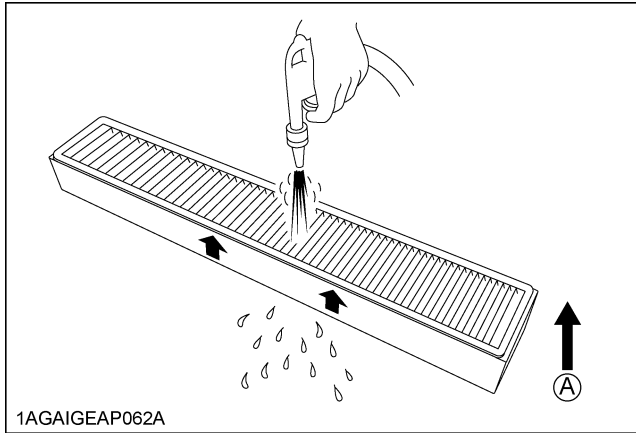

(A) "AIR CONDITIONER AIRFLOW"

NOTE :

- If the filter is very dirty:
Dip the filter in lukewarm water with mild dish washing detergent.
Move it up and down as well as left and right to loosen dirt. Rinse the filter with clean water and let it air-dry.

IMPORTANT :

- Do not use gasoline, thinner or similar chemicals to clean the filter as damage to the filter may occur.
- It may also cause an unpleasant odor in the CAB when the system is used next.

EVERY 400 HOURS

■ Cleaning Water Separator

This job should not be done in the field, but in a clean place.

1. Disconnect the connector of water sensor.
2. Close the fuel shutoff-valve.
3. Unscrew the cup and remove it, then rinse the inside with kerosene.
4. Take out the element and dip it in the kerosene to rinse.
5. After cleaning, reassemble the water separator, keeping out dust and dirt.
6. Connect the connector of water sensor.
7. Bleed the fuel system.
(See "SERVICE AS REQUIRED" in "PERIODIC SERVICE" section.)

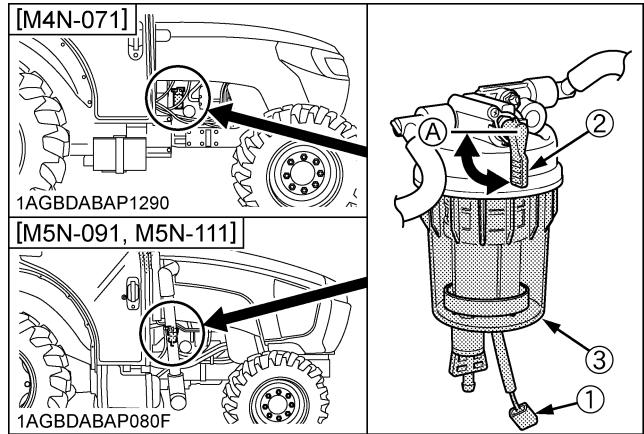

- (1) Water sensor connector
- (A) "CLOSE"
- (2) Fuel shutoff-valve
- (3) Cup

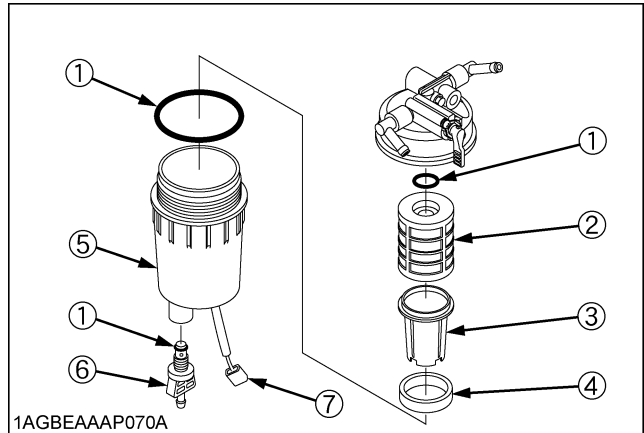

- (1) O ring
- (2) Element
- (3) Element cup
- (4) Red float
- (5) Cup
- (6) Drain plug
- (7) Water sensor connector

IMPORTANT :

- If the water separator and/or fuel filter is not well maintained, the supply pump and injector may be damaged earlier than expected.

■ Cleaning Fuel Solenoid Pump Element

[M5N-091, M5N-111]

1. Close the fuel shutoff-valve.
2. Unscrew the cover's nut and remove the cover from the fuel solenoid pump.
3. Remove the cover, magnet, and element and clean with kerosene.
4. Refer to the diagram below and reassemble the parts as they were before.
5. Open the fuel shutoff-valve.

IMPORTANT :

- When assembling the parts, be careful that no dirt or dust contacts them.
- Be sure to install the cover securely.
- After assembly, be sure to bleed the air from the fuel system. (See "Bleeding Fuel System" in "SERVICE AS REQUIRED" in "PERIODIC SERVICE".)

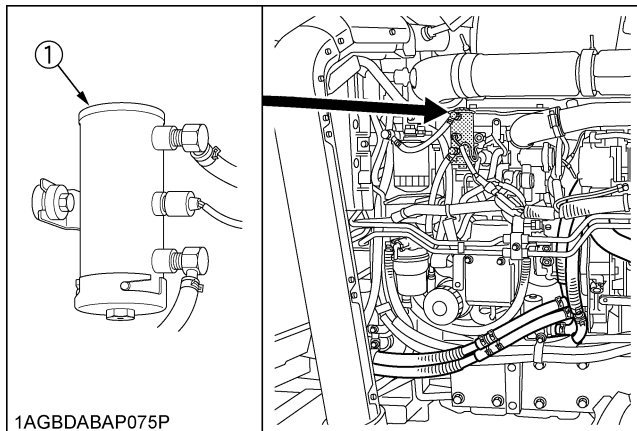

1AGBDABAP075P

(1) Fuel solenoid pump

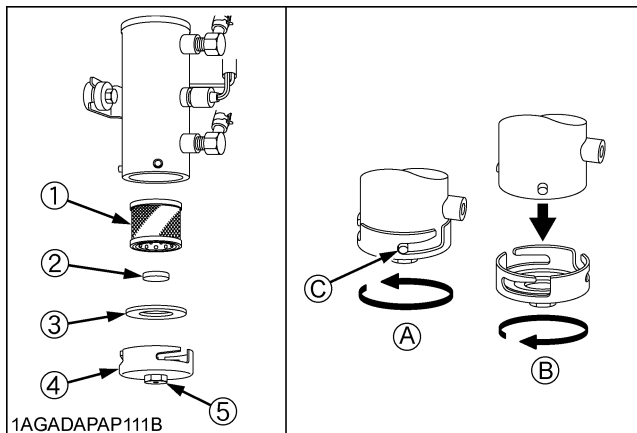

- (1) Element
- (2) Magnet
- (3) Gasket
- (4) Cover
- (5) Nut

- (A) "TIGHTEN"
 - (B) "LOOSEN"
 - (C) Pin
- "Tighten the cover until the end of the slot contacts the pin."

EVERY 500 HOURS

■ Changing Engine Oil



WARNING

To avoid personal injury or death:

- Be sure to stop the engine before changing the oil.
- Allow engine to cool down sufficiently, oil can be hot and can burn.

1. To drain the used oil, remove the drain plug at the bottom of the engine and drain the oil completely into the oil pan.
2. After draining reinstall the drain plug.
3. Fill with the new oil up to the upper notch on the dipstick. (See "LUBRICANTS" in "MAINTENANCE" section.)

Oil capacity with filter	10.7 L (11.3 U.S.qts.)
--------------------------	------------------------

IMPORTANT :

- Use DPF-compatible oil (CJ-4) for the engine.

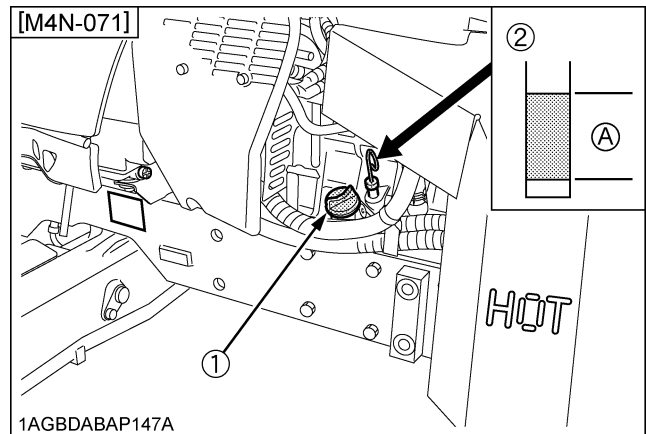

1AGBDABAP147A

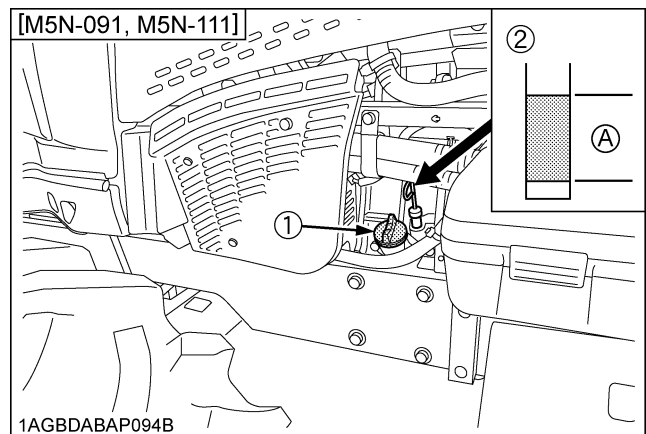

1AGBDABAP094B

- (1) Oil inlet
- (A) Oil level is acceptable within this range
- (2) Dipstick

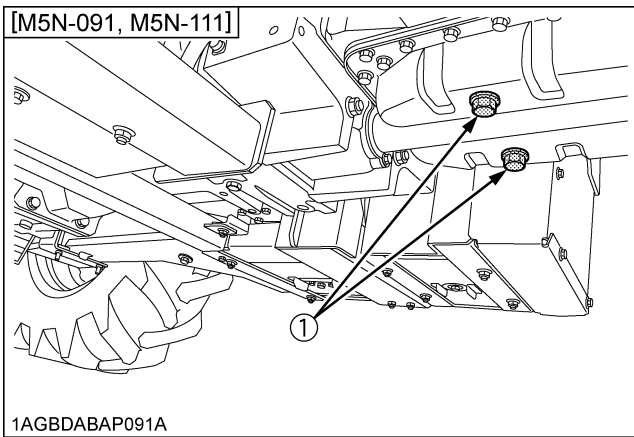
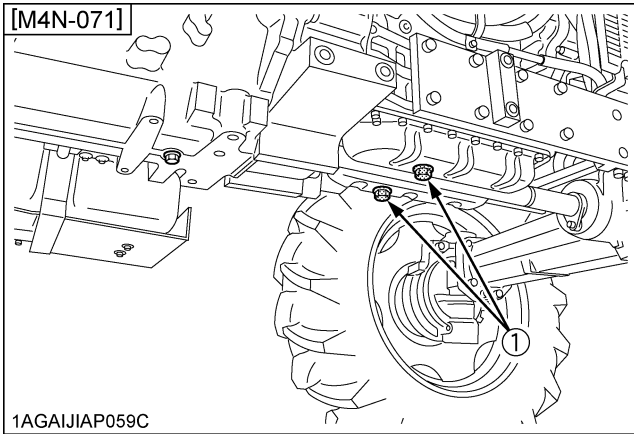

(1) Drain plug

■ Replacing Engine Oil Filter



WARNING

To avoid personal injury or death:

- Be sure to stop the engine before replacing the oil filter cartridge.
- Allow engine to cool down sufficiently, oil can be hot and can burn.

1. Remove the oil filter.
2. Put a film of clean engine oil on the rubber seal of the new filter.
3. Tighten the filter quickly until it contacts the mounting surface.
Tighten filter by hand an additional 1/2 turn only.
4. After the new filter has been replaced, the engine oil normally decreases a little. Make sure that the engine oil does not leak through the seal and be sure to check the oil level on the dipstick. Then, replenish the engine oil up to the prescribed level.

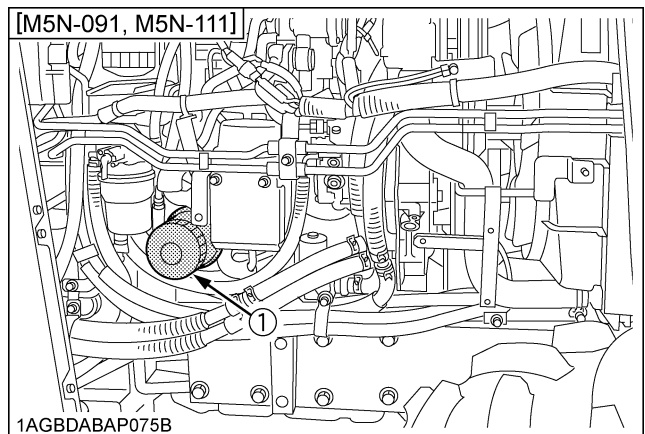
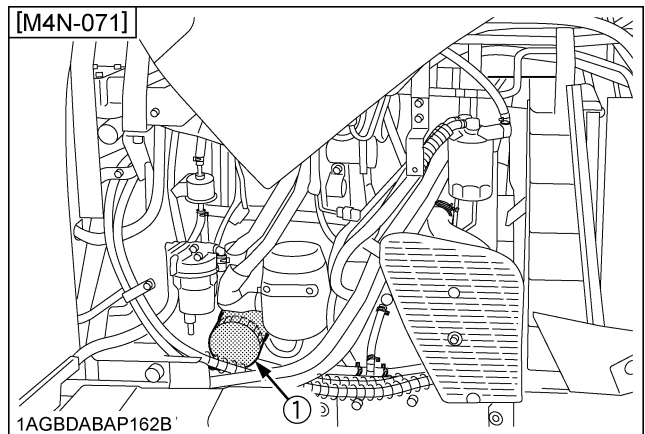

(1) Engine oil filter

IMPORTANT :

- To prevent serious damage to the engine, use only a KUBOTA genuine filter.

■ Replacing Fuel Filter

1. Remove the fuel filter.
2. Put a film of clean fuel on rubber seal of new filter.
3. Tighten the filter quickly until it contacts the mounting surface.
Tighten filter by hand an additional 1/2 turn only.
4. Bleed the fuel system.
(See "Bleeding Fuel System" in "SERVICE AS REQUIRED" in "PERIODIC SERVICE" section.)

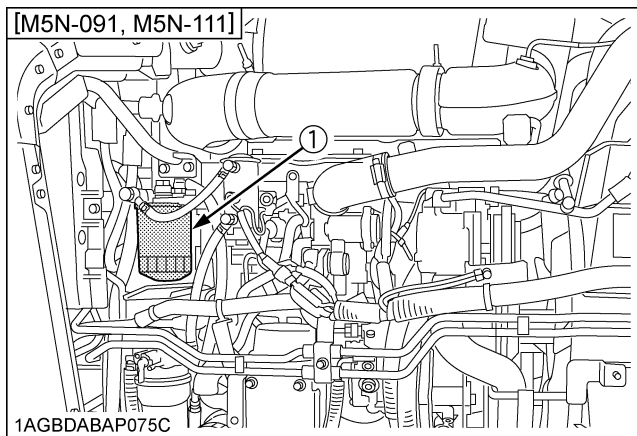
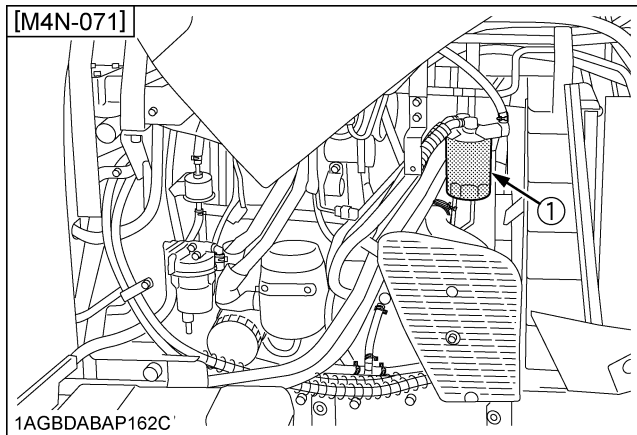

(1) Fuel filter

■ Replacing Hydraulic Oil Filter

◆ Cleaning Magnetic Filter



WARNING

To avoid personal injury or death:

- Be sure to stop the engine before changing the oil filter cartridge.
- Allow engine to cool down sufficiently, oil can be hot and can burn.

1. Remove the drain plug at the bottom of the transmission case and drain the oil completely into an oil pan.
2. After draining reinstall the drain plug.

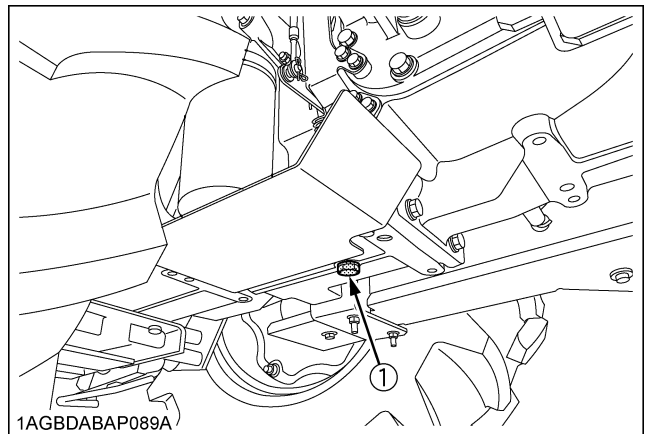

(1) Drain plug

3. Remove the oil filter.
4. Wipe off metal filings from the magnetic filter with a clean rag.

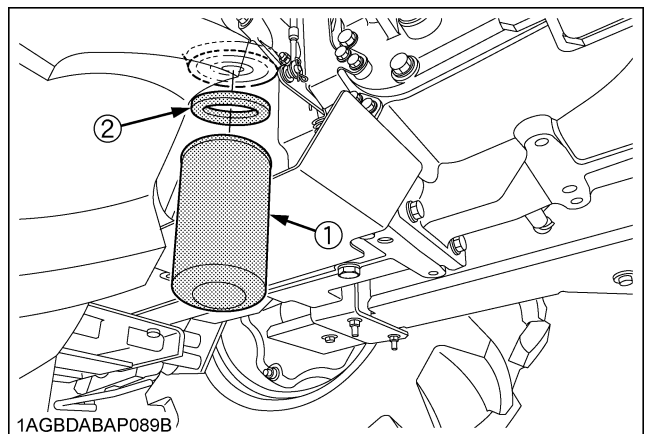

(1) Hydraulic oil filter

(2) Magnetic filter (Wipe off metal filings)

5. Put a film of clean transmission oil on the rubber seal of the new filter.

6. Tighten the filter quickly until it contacts the mounting surface.
Tighten filter by hand an additional 1/2 turn only.
7. After the new filter has been replaced, fill the transmission oil up to the upper notch on the dipstick.

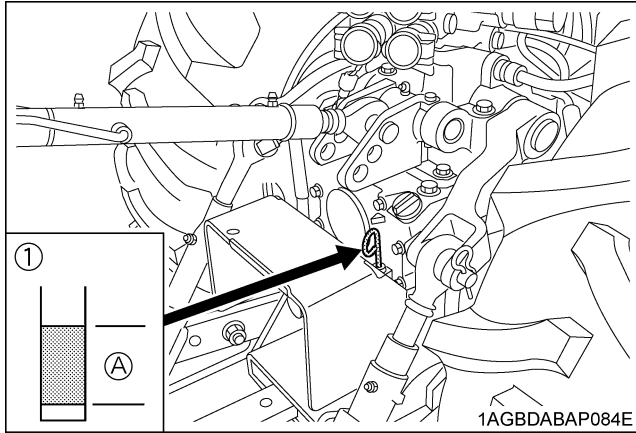

(1) Gauge (A) Oil level is acceptable within this range.

8. After running the engine for a few minutes, stop the engine and check the oil level again, add oil to the prescribed level.
9. Make sure that the transmission fluid doesn't leak pass the seal on the filter.

IMPORTANT :

- To prevent serious damage to the hydraulic system, use only a KUBOTA genuine filter.

■ Checking Power Steering Line

1. Check to see that all lines and hose clamps are tight and not damaged.
2. If hoses and clamps are found worn or damaged, replace or repair them at once.

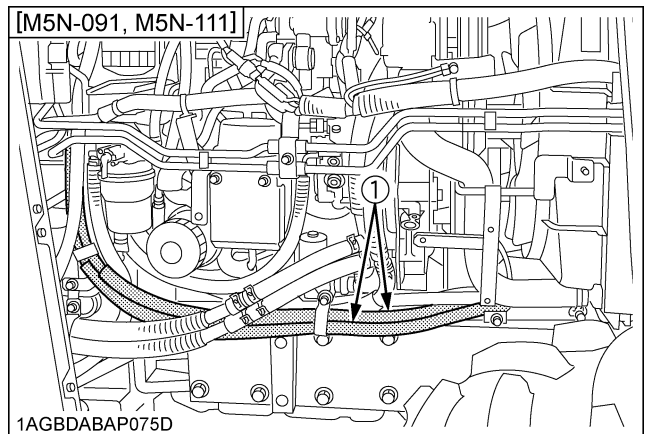
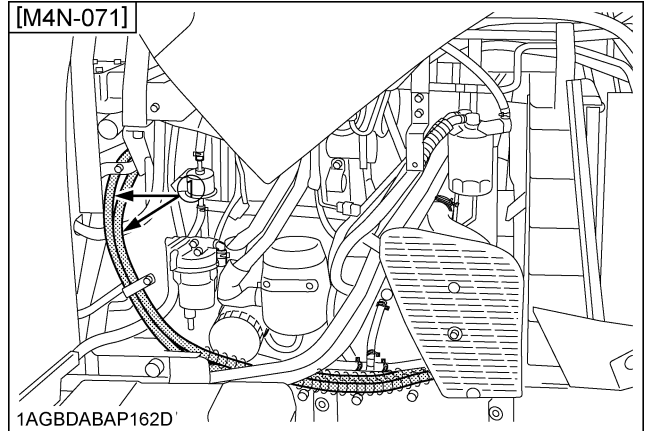

(1) Power steering pressure hoses

■Checking Radiator Hose and Clamp

Check to see if radiator hoses are properly fixed every 500 hours of operation.

1. If hose clamps are loose or water leaks, tighten bands securely.
2. Replace hoses and tighten hose clamps securely, if radiator hoses are swollen, hardened or cracked. Replace hoses and hose clamps every 4 years or earlier if checked and found that hoses are swollen, hardened or cracked.

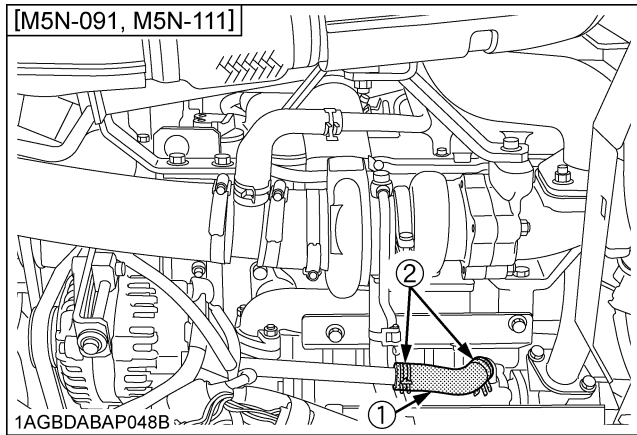
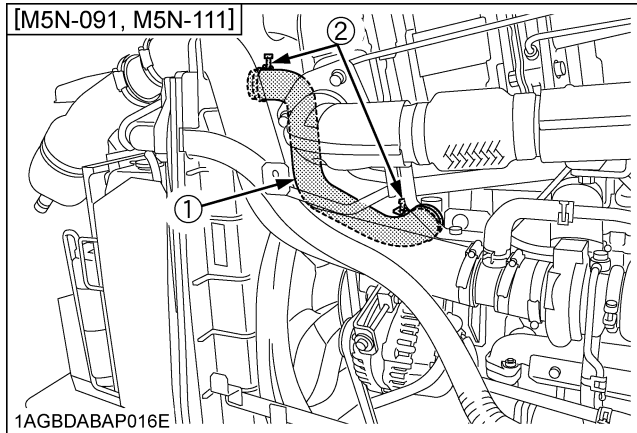

- (1) Radiator hoses
(2) Hose clamps

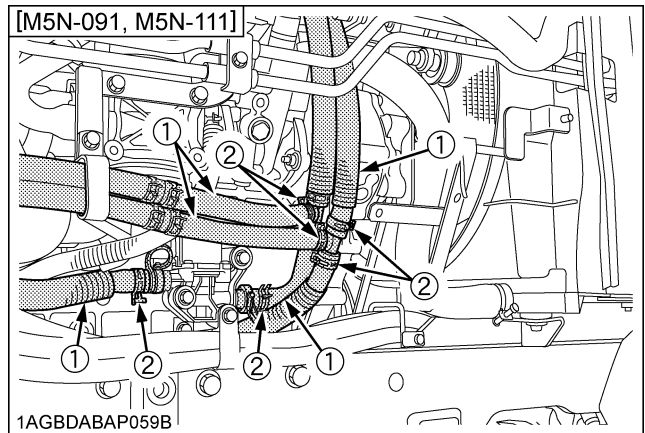
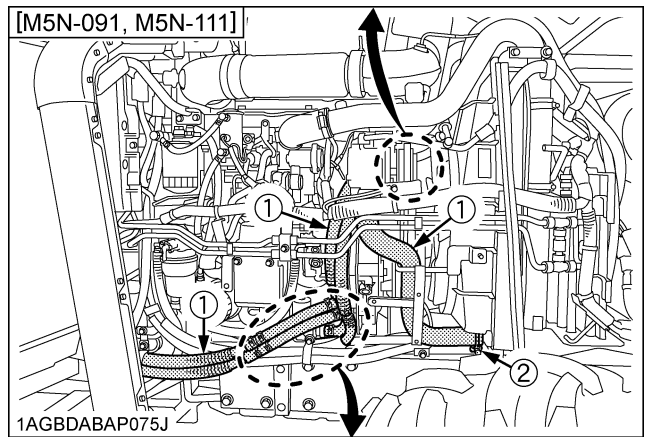
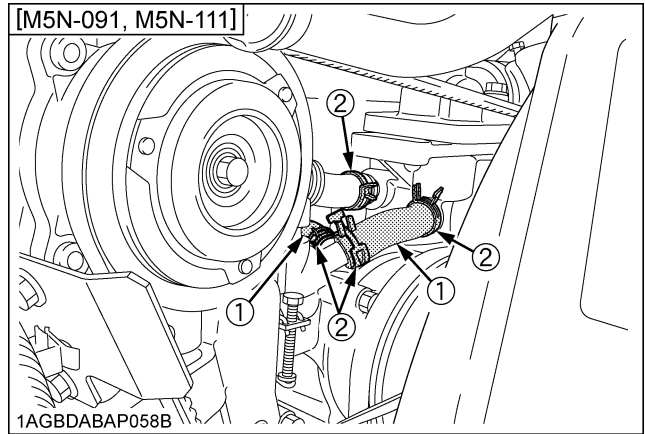

- (1) Radiator hoses
(2) Hose clamps

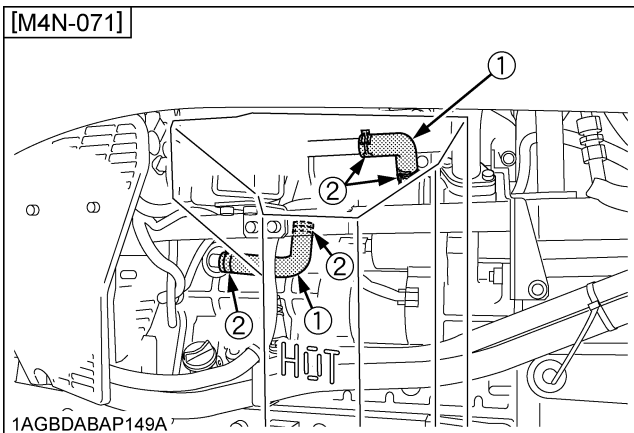
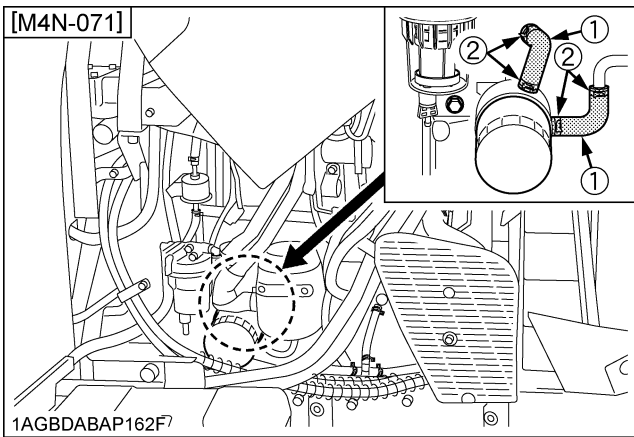
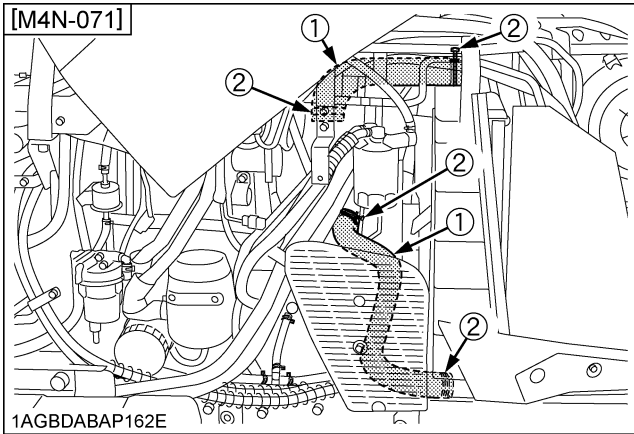

(1) Radiator hoses
(2) Hose clamps

◆ **Precaution at Overheating**

Take the following actions in the event the coolant temperature is nearly or more than the boiling point, what is called "Overheating"

1. Park the tractor in a safe place and keep the engine unloaded idling.
2. Don't stop the engine suddenly, but stop it after about 5 minutes of unloaded idling.

3. Keep yourself well away from the machine for further 10 minutes or while the steam blows out.
4. Check that there are no dangers such as burns. Get rid of the causes of overheating according to the manual, see "TROUBLESHOOTING" section, and then, start again the engine.

■ **Checking Fuel Line**

1. Check to see that all lines and hose clamps are tight and not damaged.
2. If hoses and clamps are found worn or damaged, replace or repair them at once.

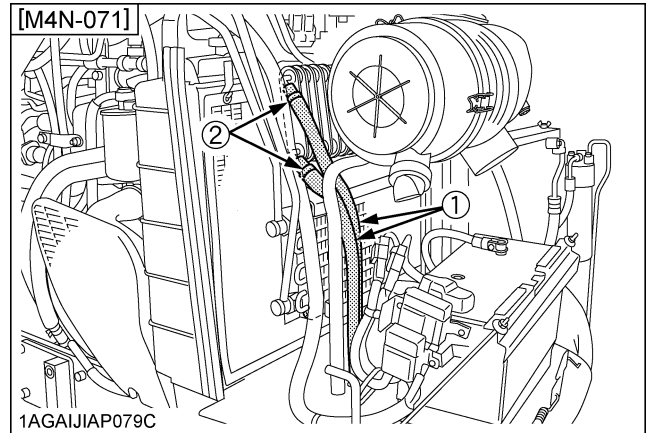
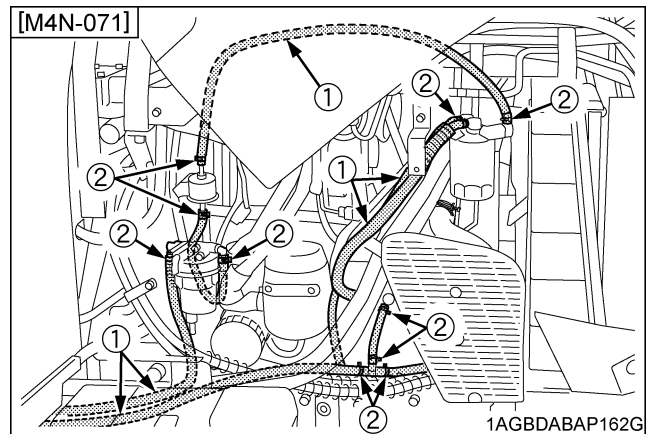

(1) Fuel lines
(2) Clamp bands

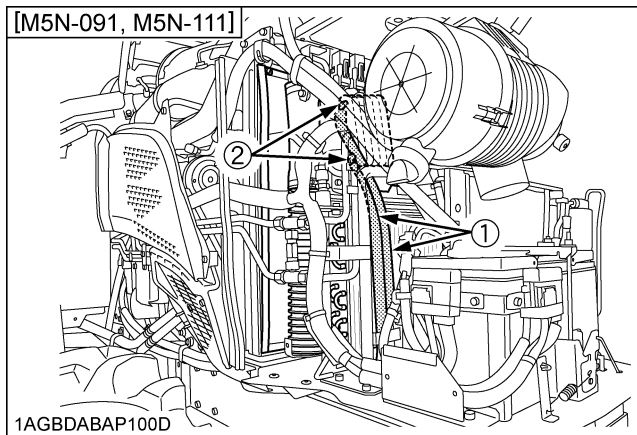
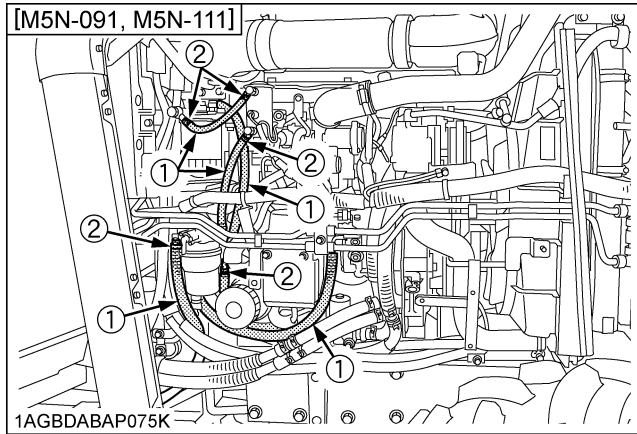

- (1) Fuel lines
- (2) Clamp bands

NOTE :

- If the fuel line is removed, be sure to properly bleed the fuel system.
(See "Bleeding Fuel System" in "SERVICE AS REQUIRED" in "PERIODIC SERVICE" section.)

■ Checking Intake Air Line

1. Check to see that hoses and hose clamps are tight and not damaged.
2. If hoses and clamps are found worn or damaged, replace or repair them at once.

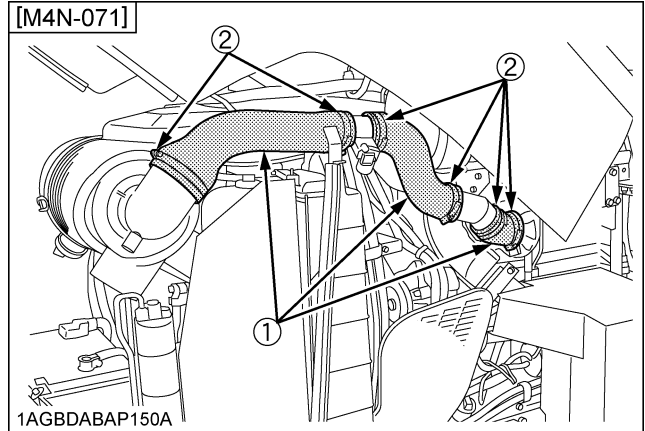

- (1) Hose
- (2) Hose clamps

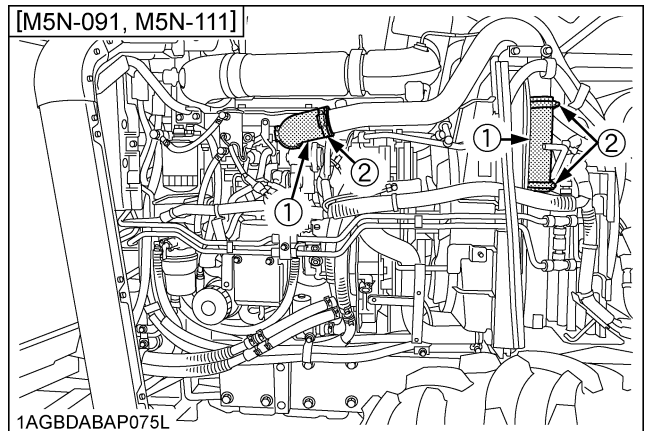
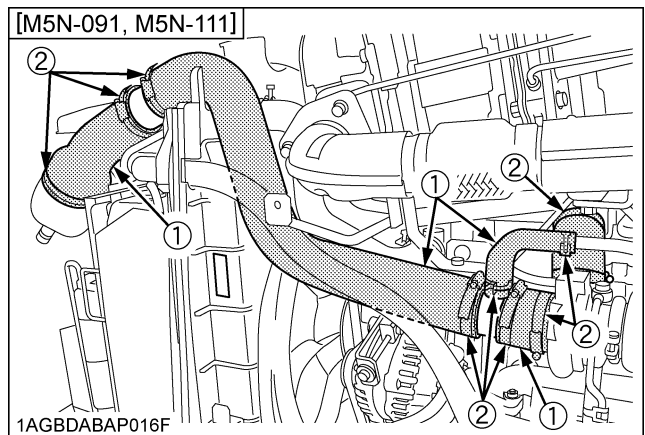

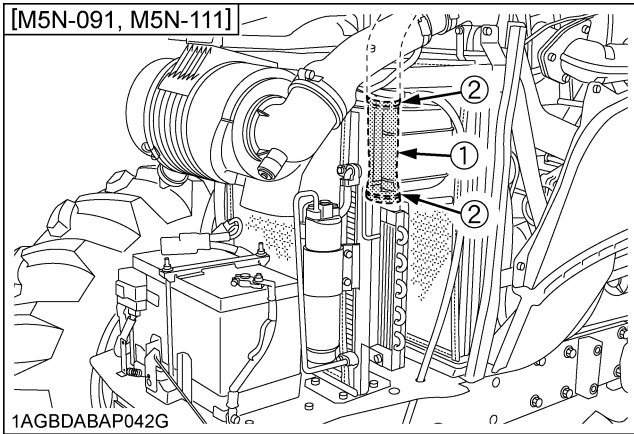

(1) Hose
(2) Hose clamps

■ Checking Lift Cylinder Hose

1. Check to see that hoses and hose clamps are tight and not damaged.
2. If hoses and clamps are found worn or damaged, replace or repair them at once.

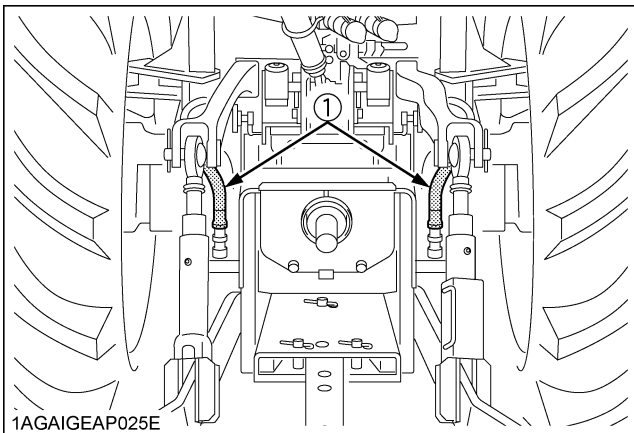

(1) Lift cylinder hoses

■ Checking Air Conditioner Pipe and Hose

1. Check to see that all lines and hose clamps are tight and not damaged.
2. If hoses and clamps are found worn or damaged, consult your local KUBOTA Dealer for this service.

■ Checking Brake Hose

1. Check to see that hoses and hose clamps are tight and not damaged.
2. If hoses and clamps are found worn or damaged, consult your local KUBOTA Dealer for this service.

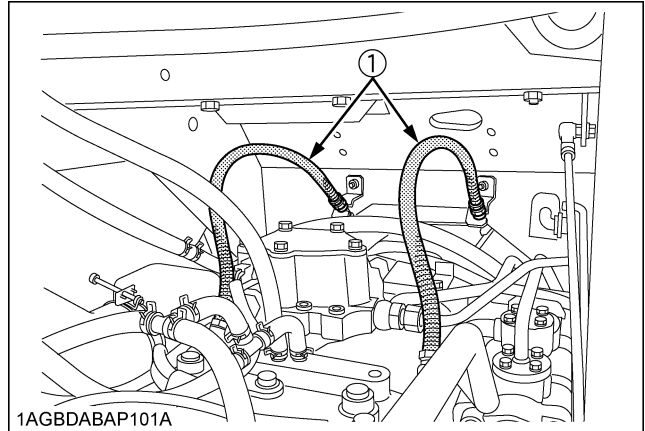

(1) Brake hose

EVERY 600 HOURS

■ Adjusting Front Axle Pivot

If the front axle pivot pin adjustment is not correct, front wheel vibration can occur causing vibration in the steering wheel.

◆ Adjusting procedure

Loosen the lock nut, screw-in the adjusting screw until seated, then tighten the screw with an additional 1/6 turn. Re-tighten the lock nut.

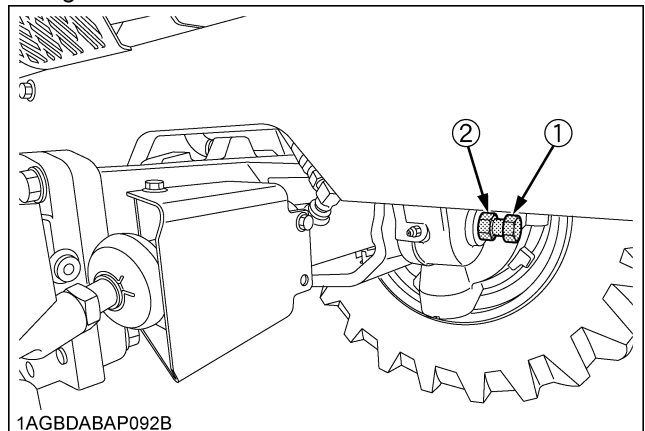

(1) Adjusting screw
(2) Lock nut

EVERY 1000 HOURS

■ Changing Transmission Fluid



WARNING

To avoid personal injury or death:

- Allow engine to cool down sufficiently, oil can be hot and can burn.

1. To drain the used oil, remove the drain plug at the bottom of the transmission case and drain the oil completely into the oil pan.
2. After draining reinstall the drain plug.
3. Fill with the new KUBOTA SUPER UDT fluid up to the upper notch on the dipstick.
(See "LUBRICANTS" in "MAINTENANCE" section.)
4. After running the engine for a few minutes, stop it and check the oil level again; add oil to prescribed level.

Oil capacity	52 L (54.9 U.S.qts)
--------------	---------------------

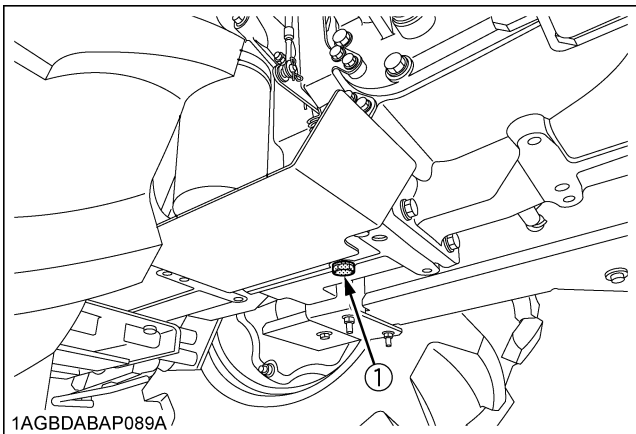

(1) Drain plug

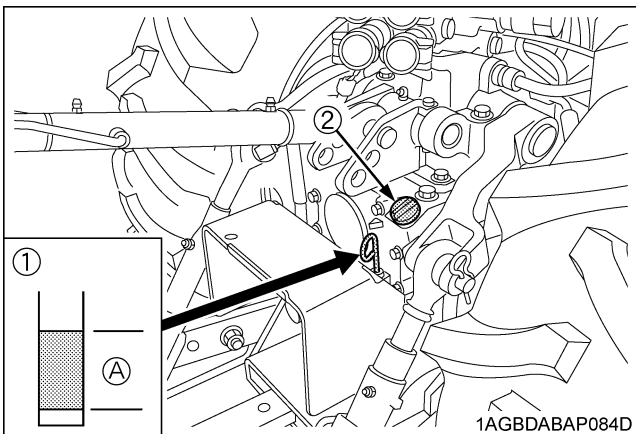

(1) Dipstick
(2) Oil inlet

(A) Oil level is acceptable within this range.

IMPORTANT :

- Do not operate the tractor immediately after changing the transmission fluid.
Run the engine at medium speed for a few minutes to prevent damage to the transmission.

■ Changing Front Axle Gear Case Oil & Front Differential Case Oil

1. To drain the used oil, remove the drain plugs at the both front axle gear cases and filling plugs, and drain the oil completely into the oil pan.
2. After draining reinstall the drain plugs.
3. Remove the oil level check plug at the front differential case.
4. Fill with the new oil of the specified amount from both filling ports on the front axle gear case.
5. Finally fill with the new oil up to the lower rim of check plug port on the front differential case.
(See "LUBRICANTS" in "MAINTENANCE" section.)
6. After checking oil is visible through the opening of check plug, reinstall filling plugs and check plug.

	Oil capacity
Front Axle Gear Case	3.0 L (3.2 U.S.qts.) for each side
Front Differential Case	5.0 L (5.3 U.S.qts.)

NOTE :

- Fill up specified amount certainly although it takes time to pour the oil.

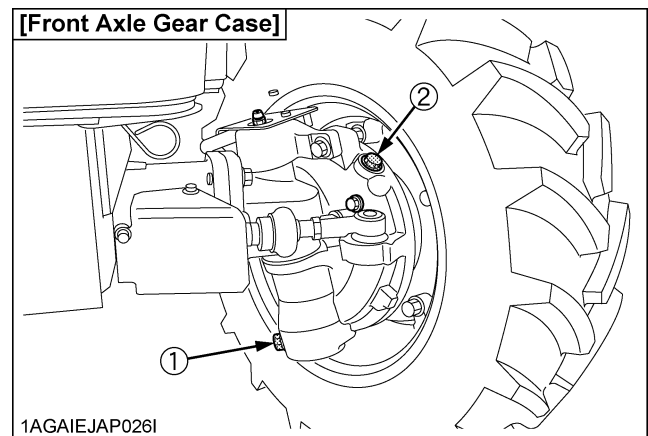

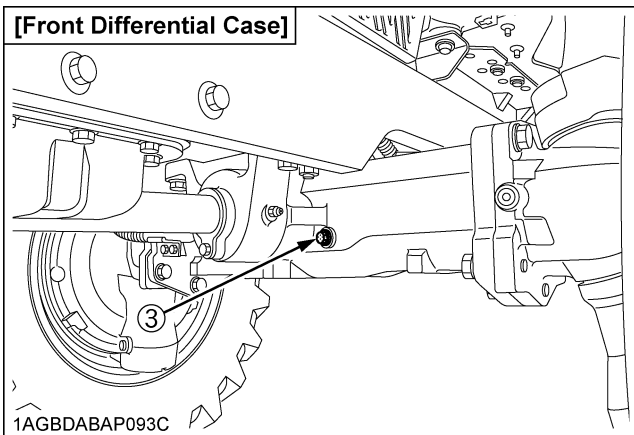
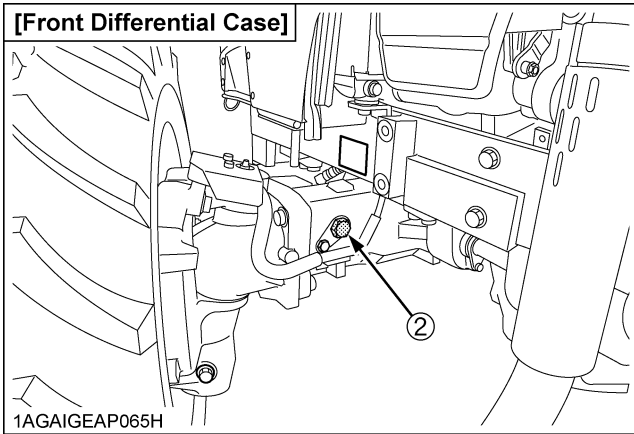

- (1) Drain plug
- (2) Filling plug
- (3) Check plug

■ Adjusting Engine Valve Clearance
Consult your local KUBOTA Dealer for this service.

EVERY 1000 HOURS or 1 YEAR

Be sure to do the following servicing once every 1000 hours or yearly, whichever comes first.

■ Replacing Air Cleaner Primary Element and Secondary Element
(See "Cleaning Air Cleaner Primary Element" in "EVERY 100 HOURS" in "PERIODIC SERVICE" section.)

■ Checking Exhaust Manifold
Consult your local KUBOTA Dealer for this service.

EVERY 1500 HOURS

■ Cleaning Fuel Injector Nozzle Tip
Consult your local KUBOTA Dealer for this service.

■ Checking DEF/AdBlue® Injector Tip [M5N-091, M5N-111]
Consult your local KUBOTA Dealer for this service.

■ Checking DEF/AdBlue® Line [M5N-091, M5N-111]

1. Check to see that all lines from the DEF/AdBlue® injector to the tank are securely connected and not damaged.
2. If hoses and clamps are found worn or damaged, replace or repair them at once.

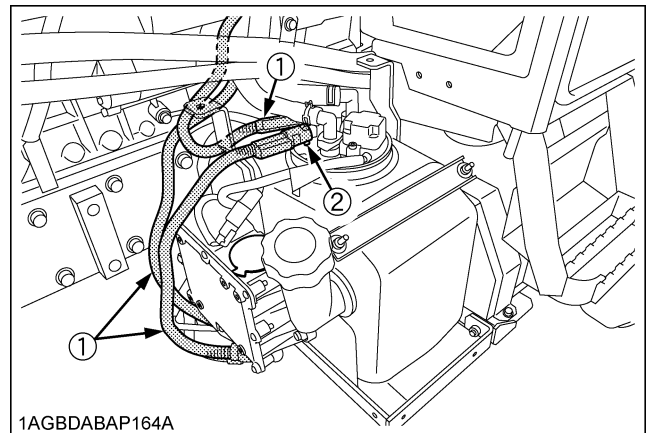

- (1) DEF/AdBlue® lines
- (2) Clamp bands

■ Replacing Oil Separator Element

⚠ WARNING
To avoid personal injury or death:

- Be sure to stop the engine before replacing the oil separator element.

1. Remove the cover and take out the element. Wipe off oil and the carbon in the case with a clean rag.
2. Fit a new oil separator element.
3. Tighten the cover.

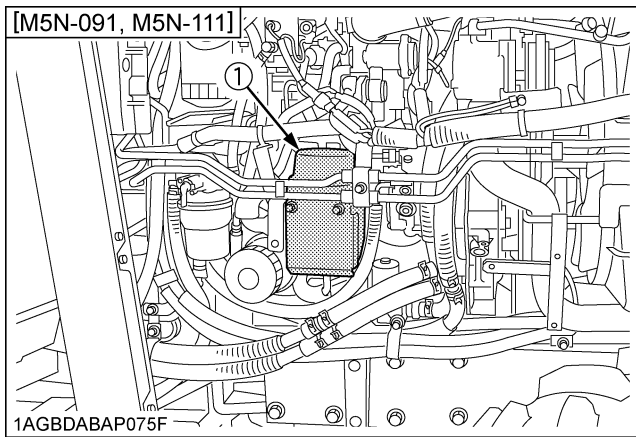
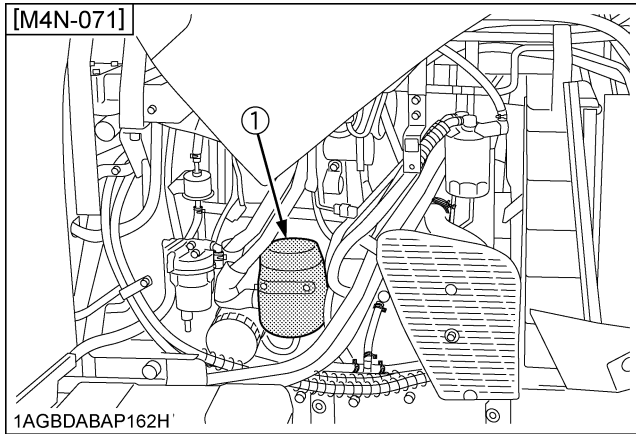

(1) Oil separator

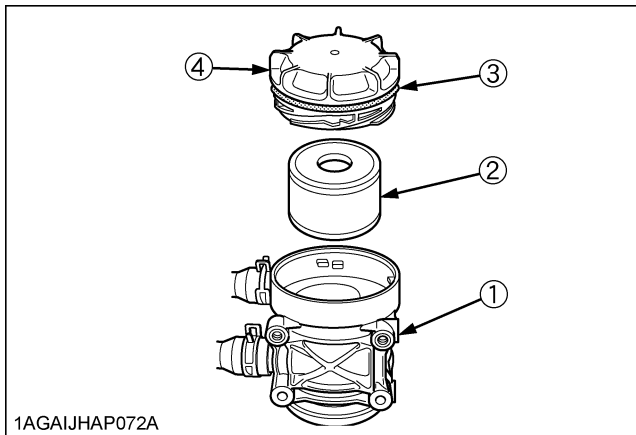

- (1) Body
- (2) Oil separator element
- (3) Gasket
- (4) Cover

■ Checking PCV (Positive Crankcase Ventilation) Valve

Consult your local KUBOTA Dealer for this service.

■ Checking and Cleaning EGR Cooler

Consult your local KUBOTA Dealer for this service.

EVERY 2000 HOURS or 2 YEARS

Be sure to do the following servicing once every 2000 hours or biennially, whichever comes first.

■ Flushing Cooling System and Changing Coolant

⚠ WARNING

To avoid personal injury or death:

- Do not remove radiator cap while coolant is hot. When cool, slowly rotate cap to the first stop and allow sufficient time for excess pressure to escape before removing the cap completely.

1. Stop the engine, remove the key and let it cool down.
2. To drain the coolant, open the radiator drain plug, remove the drain plug and remove radiator cap. The radiator cap must be removed to completely drain the coolant.
3. After all coolant is drained, reinstall the drain plug.
4. Fill with clean soft water and cooling system cleaner.
5. Follow directions of the cleaner instruction.
6. After flushing, fill with clean soft water and anti-freeze until the coolant level is just below the radiator cap. Install the radiator cap securely.
7. Fill with coolant up to the "FULL" mark of recovery tank.
8. Start and operate the engine for few minutes.
9. Stop the engine, remove the key and let cool.
10. Check coolant level of recovery tank and add coolant if necessary.
11. Properly dispose of used coolant.

Coolant capacity	10 L (11 U.S.qts.)
------------------	--------------------

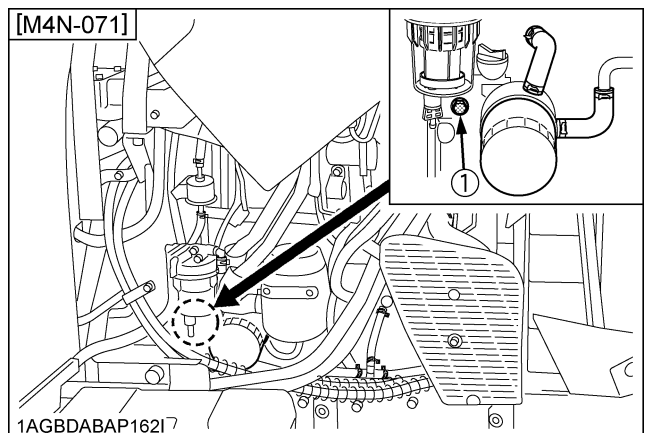

(1) Drain plug

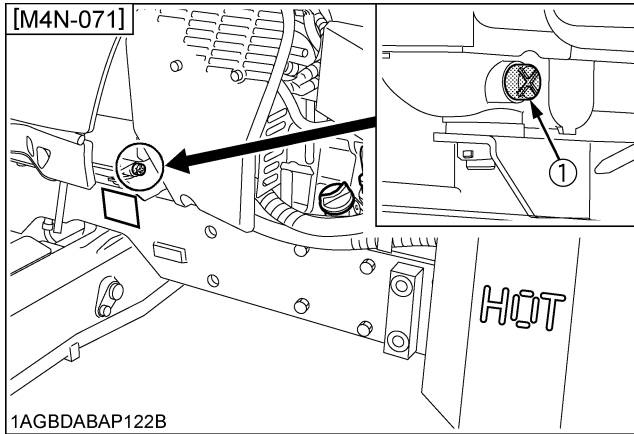

(1) Drain plug ((+) Plus screwdriver)

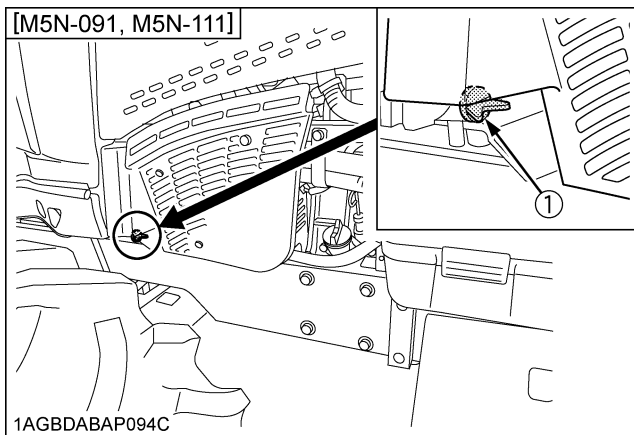
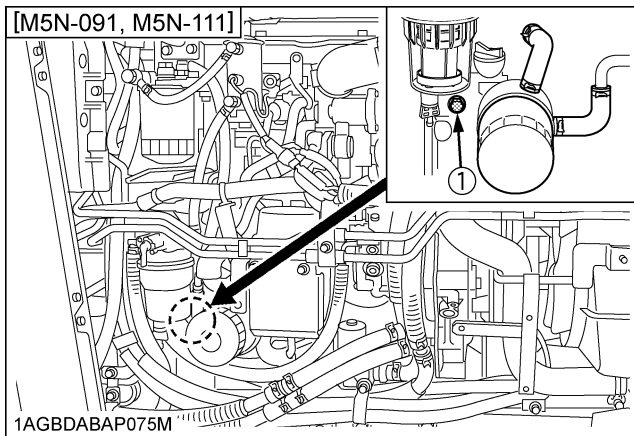

(1) Drain plug

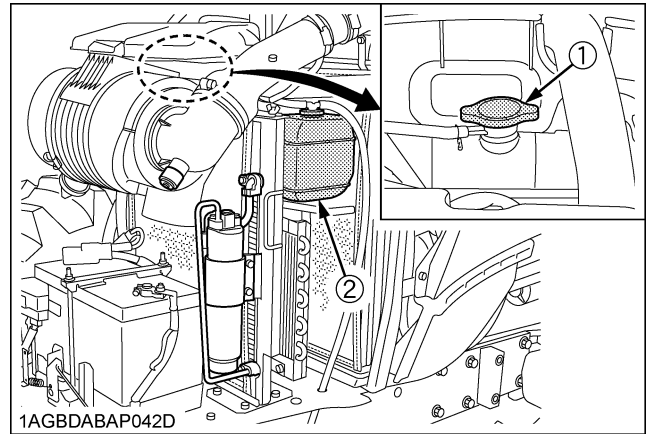

(1) Radiator cap
(2) Recovery tank

IMPORTANT :

- Do not start engine without coolant.
- Use clean, fresh soft water and anti-freeze to fill the radiator and recovery tank.
- When mixing the anti-freeze with water, the anti-freeze mixing ratio is 50%.
- Securely tighten radiator cap. If the cap is loose or improperly fitted, water may leak out and the engine could overheat.

NOTE :

- On cab type machines, coolant circulates through the heater. This means that one more liter or so of coolant is required.

In changing coolant, pour coolant up to the filler port of the recovery tank. Turn ON the heater (shift the temperature control lever toward WARM), and run the engine for a while in order to warm coolant. Then stop the engine.

When coolant has cooled down, some of the coolant in the recovery tank is sucked. Now the recovery tank is appropriately filled with coolant.

■ **Anti-Freeze**

! WARNING

To avoid personal injury or death:

- When using antifreeze, put on some protection such as rubber gloves. (Antifreeze contains poison.)
- If it is swallowed, seek immediate medical help. Do NOT make a person throw up unless told to do so by poison control or a health care professional. Use standard first aid and CPR for signs of shock or cardiac arrest. Call your local Poison Control Center or your local emergency number for further assistance.
- When antifreeze comes in contact with the skin or clothing, wash it off immediately.
- Do not mix different types of Antifreeze.

The mixture can produce chemical reaction causing harmful substances.

- Antifreeze is extremely flammable and explosive under certain conditions. Keep fire and children away from antifreeze.
- When draining fluids from the engine, place some container underneath the engine body.
- Do not pour waste onto the ground, down a drain, or into any water source.
- Also, observe the relevant environmental protection regulations when disposing of antifreeze.

Always use a 50/50 mix of long-life coolant and clean soft water in KUBOTA engines.

Consult your local KUBOTA Dealer concerning coolant for extreme conditions.

1. Long-life coolant (hereafter LLC) comes in several types. Use ethylene glycol (EG) type for this engine.
2. Before employing LLC-mixed cooling water, fill the radiator with fresh water and empty it again. Repeat this procedure 2 or 3 times to clean up the inside.
3. Mixing the LLC
Premix 50% LLC with 50% clean soft water. When mixing, stir it up well, and then fill into the radiator.
4. The procedure for the mixing of water and antifreeze differs according to the make of the antifreeze and the ambient temperature. Refer to SAE J1034 standard, more specifically also to SAE J814c.

Vol % Anti-freeze	Freezing Point		Boiling Point*	
	°C	°F	°C	°F
50	-37	-34	108	226

* At 1.013×10^5 Pa (760mmHg) pressure (atmospheric). A higher boiling point is obtained by using a radiator pressure cap which permits the development of pressure within the cooling system.

5. Adding the LLC
 - (1) Add only water if the mixture reduces in amount by evaporation.
 - (2) If there is a mixture leak, add the LLC of the same manufacturer and type in the same mixture percentage.
 - * Never add any long-life coolant of different manufacturer. (Different brands may have different additive components, and the engine may fail to perform as specified.)
6. When the LLC is mixed, do not employ any radiator cleaning agent. The LLC contains anticorrosive agent. If mixed with the cleaning agent, sludge may build up, adversely affecting the engine parts.
7. Kubota's genuine long-life coolant has a service life of 2 years. Be sure to change the coolant every 2000 hours or every 2 years whichever comes faster.

NOTE :

- The above data represent industry standards that necessitate a minimum glycol content in the concentrated antifreeze.

EVERY 3000 HOURS

■ Checking Turbocharger

Consult your local KUBOTA Dealer for this service.

■ Checking Supply Pump

Consult your local KUBOTA Dealer for this service.

■ Checking Intake Air Heater

Consult your local KUBOTA Dealer for this service.

■ Checking and Cleaning EGR System

Consult your local KUBOTA Dealer for this service.

■ Cleaning DPF Muffler

◆ Removal of ash

The longer the DPF operates, the more ash (burnt residue) is collected in the filter. Too much ash build-up adversely affects the DPF performance. Consult your local KUBOTA Dealer to clean the filter.

IMPORTANT :

- The DPF needs cleaning with a specific cleaning device. Do not clean the DPF by disassembling, and attempt by yourself, consult your local KUBOTA Dealer.

■ Checking DEF/AdBlue® injector

[M5N-091, M5N-111]

Consult your local KUBOTA Dealer for this service.

■ Replacing DEF/AdBlue® Pump Filter

[M5N-091, M5N-111]

1. Loosen the bolts and remove the tool box and the tank cover.

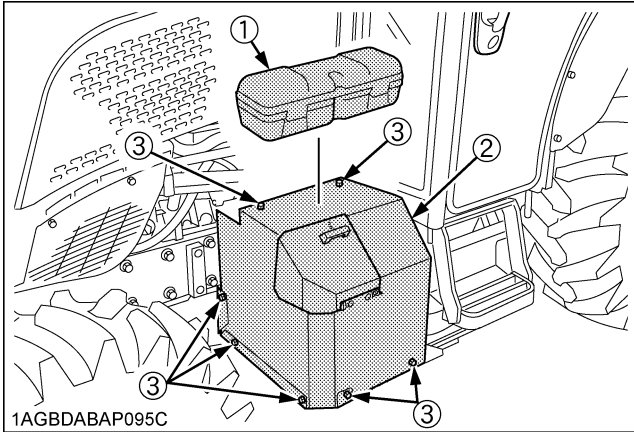

- (1) Tool box
 (2) Tank cover
 (3) Bolt

2. Clean up around the plug and remove the plug.
3. Loosen the top of filter assembly and remove it from pump.
4. Replace the filter assembly with new one.

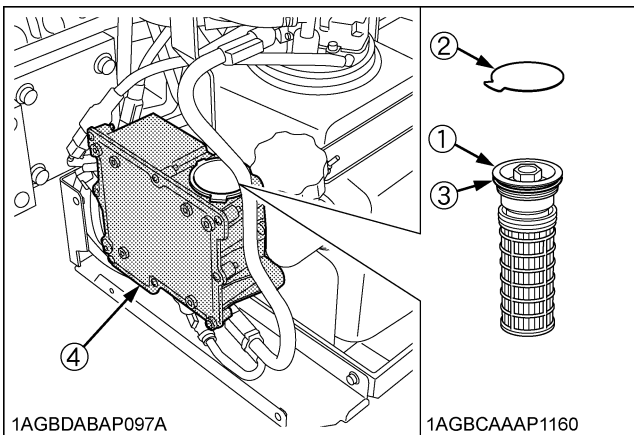

- (1) Filter assembly
 (2) Plug
 (3) O-ring
 (4) DEF/AdBlue® pump

NOTE :

- Even after stopping the engine, the injector cooling DEF/AdBlue® fluid continues to circulate through the circuit for a couple of minutes. When this circulation has ended, do the replacement job. (During cooling, the fluid's circulating noise is heard.)
- Do not apply oil to the O-ring of the filter.

EVERY 1 YEAR

■ Checking Antifrost Heater for Oil Separator

(if equipped)

Consult your local KUBOTA Dealer for this service.

■ Checking CAB Isolation Cushion

Check the cushion for any breakage or fatigue. Replace them if they are deteriorated.

■ Checking DPF Differential Pressure Sensor Pipe

Consult your local KUBOTA Dealer for this service.

■ Checking EGR Pipe

Consult your local KUBOTA Dealer for this service.

EVERY 2 YEARS

■ Cleaning Master Cylinder Filter

Consult your local KUBOTA Dealer for this service.

■ Replacing Oil Separator Hose

Consult your local KUBOTA Dealer for this service.

■ Replacing DPF Differential Pressure Sensor Hose

Consult your local KUBOTA Dealer for this service.

■ Replacing EGR Cooler Hose

Consult your local KUBOTA Dealer for this service.

■ Replacing Boost Sensor Hose

Consult your local KUBOTA Dealer for this service.

EVERY 3 YEARS

■ Replacing Parking Brake Cable

Consult your local KUBOTA Dealer for this service.

EVERY 4 YEARS

■ Replacing Radiator Hose (Water pipes)

Replace the hoses and clamps.

(See "Checking Radiator Hose and Clamp" in "EVERY 500 HOURS" in "PERIODIC SERVICE" section.)

■ Replacing Fuel Hose

Consult your local KUBOTA Dealer for this service.

■ Replacing Intake Air Line

Consult your local KUBOTA Dealer for this service.

■ Replacing Oil Cooler Line

Consult your local KUBOTA Dealer for this service.

■ Replacing Power Steering Hose

Consult your local KUBOTA Dealer for this service.

■ Replacing Lift Cylinder Hose

Consult your local KUBOTA Dealer for this service.

■ Replacing Brake Hose

Consult your local KUBOTA Dealer for this service.

■ Replacing Master Cylinder Kit

Consult your local KUBOTA Dealer for this service.

■ Replacing Equalizer Kit

Consult your local KUBOTA Dealer for this service.

■ Replacing Brake Seal 1 and 2

Consult your local KUBOTA Dealer for this service.

■ Replacing Air Conditioner Hose

Consult your local KUBOTA Dealer for this service.

SERVICE AS REQUIRED

■ Bleeding Fuel System

Air must be removed:

1. When the fuel filter or lines are removed.
2. When water is drained from water separator.
3. When tank is completely empty.
4. After the tractor has not been used for a long period of time.

◆ Bleeding procedure is as follows:

1. Fill the fuel tank with fuel, and open the fuel shutoff-valve.

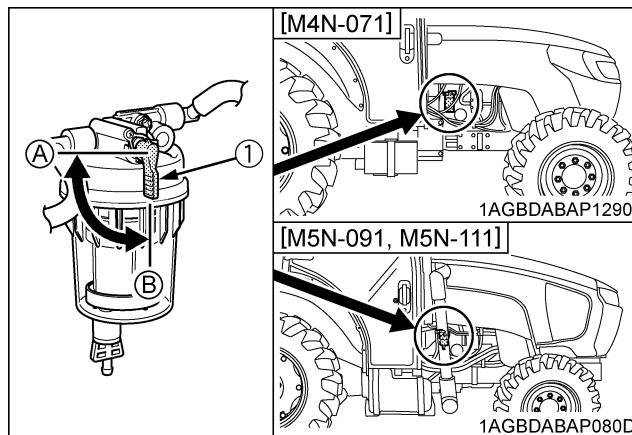

(1) Fuel shutoff-valve

(A) "CLOSE"

(B) "OPEN"

2. Disconnect the heater connector.

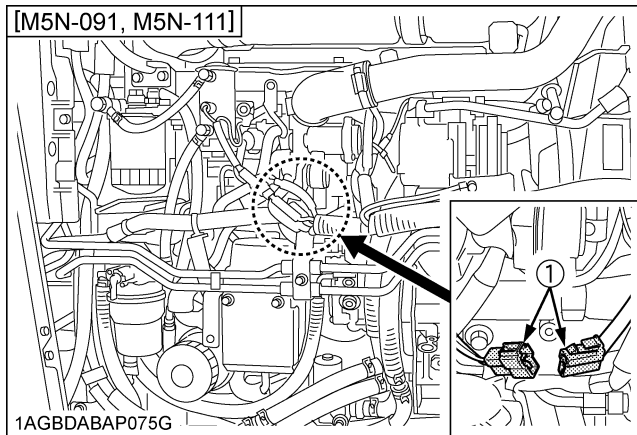
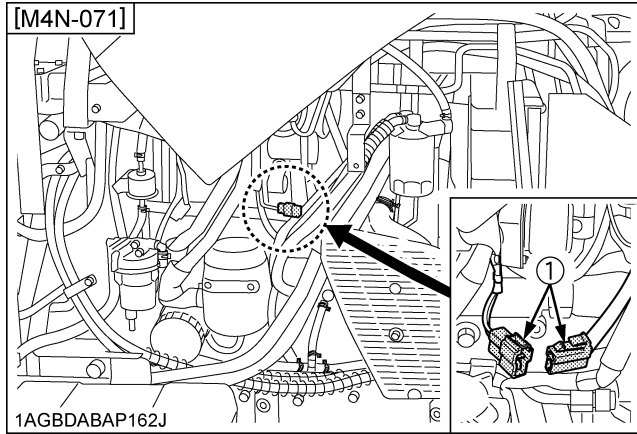

(1) Connector

IMPORTANT :

- Do not try air-bleeding with the heater in operation. Otherwise the battery may get damaged.

3. Turn ON and OFF the key switch repeatedly 10 times or so at the following intervals. This lets the air out of the fuel line.

- (1) Key switch ON time: 30 seconds
- (2) Key switch OFF time: 15 seconds

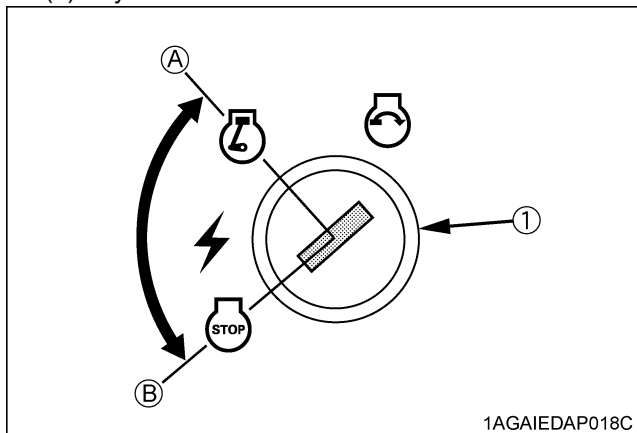

(1) Key switch

- (A) "ON"
- (B) "OFF"

4. Connect the heater connector.

5. Set the hand throttle lever at the maximum speed position, turn the key switch to start the engine and then reset the throttle lever at the mid speed (around 1500 rpm) position.

If engine doesn't start, try it several times at 30 second intervals.

IMPORTANT :

- Do not hold key switch at engine start position for more than 10 seconds continuously. If more engine cranking is needed, try again after 30 seconds.

6. Accelerate the engine to remove the small portion of air left in the fuel system.

7. If air still remains and the engine stops, repeat the above steps.

■ Bleeding Brake System

Consult your local KUBOTA Dealer for this service.

■ Draining Clutch Housing Water

The tractor is equipped with a drain plug under the clutch housing.

After operating in rain, snow or if the tractor has been washed, water may get into the clutch housing.

Remove the drain plug and drain the water, then install the plug again.

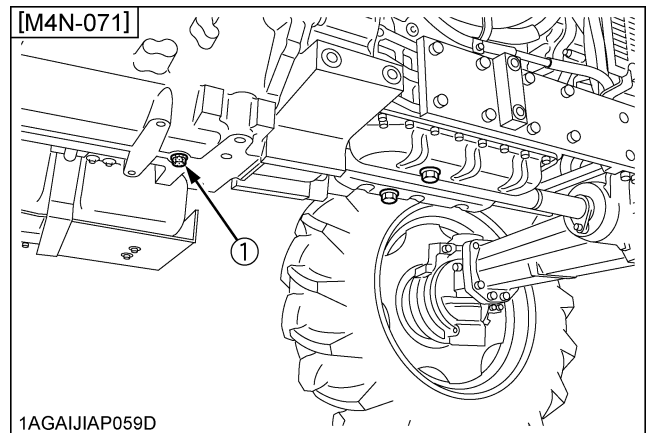

1AGAIJIAP059D

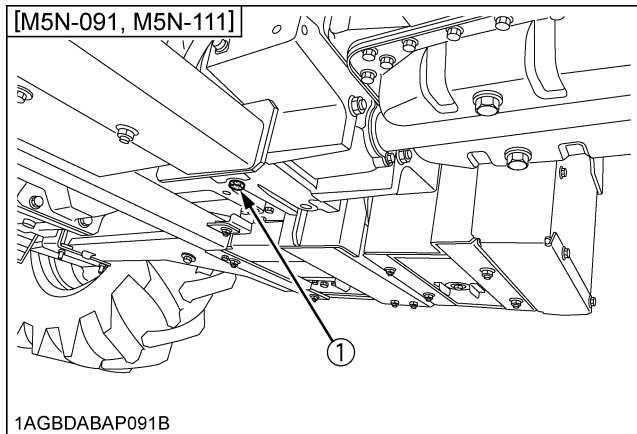

(1) Water drain plug

■ Replacing Fuse

The tractor electrical system is protected from potential damage by fuses.

A blown fuse indicates that there is an overload or short somewhere in the electrical system.

If any of the fuses should blow, replace with a new one of the same capacity.

IMPORTANT :

- Before replacing a blown fuse, determine why the fuse blew and make any necessary repairs. Failure to follow this procedure may result in serious damage to the tractor electrical system. Refer to the "TROUBLESHOOTING" section of this manual or your local KUBOTA Dealer for specific information dealing with electrical problems.

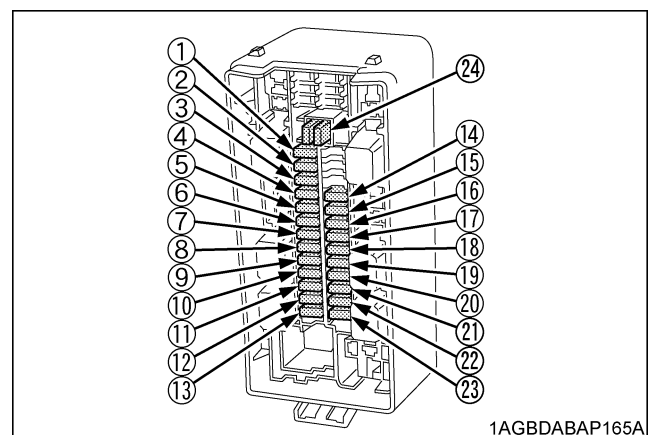
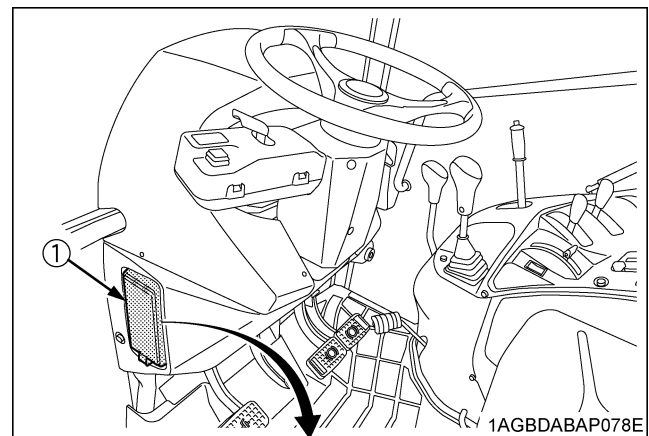

Fuse No.	Capacity (A)	Protected circuit
(1)	5	Spare Fuse
(2)	10	Spare Fuse
(3)	15	Spare Fuse
(4)	20	Spare Fuse
(5)	15	Work Light (Rear)
(6)	15	Work Light (Front)
(7)	15	Cigarette Lighter
(8)	30	Air Conditioner (Fan Motor)
(9)	10	Air Conditioner (Compressor)
(10)	20	Work Light (Front Side)
(11)	5	Transmission Control
(12)	15	Loader Plug
(13)	15	ECU
(14)	5	Starter Relay
(15)	5	Radio
(16)	5	Air Conditioner (Control)
(17)	15	Wiper
(18)	10	Alternator, PTO, Engine
(19)	5	Meter
(20)	10	Turn Signal, Stop Lamp
(21)	10	Back Up (Meter)
(22)	20	Head Light
(23)	20	Flasher (Hazard)
(24)	5	Back Up (ECU)
(25)	Fuse Puller	
(26)	15	Spare Fuse
(27)	20	Spare Fuse
(28)	20	Defogger
(29)	20	Rear Window Defogger
(30)	15	Work Light (Option)

[M5N-091, M5N-111]

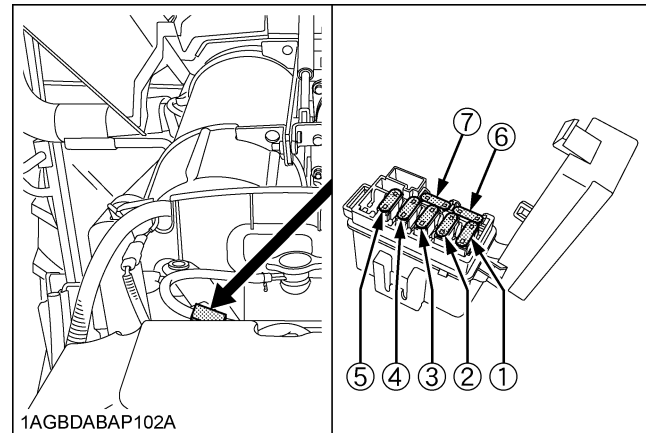

Fuse No.	Capacity (A)	Protected circuit
(1)	30	CRS system fuel pump
(2)	20	SCR system
(3)	30	SCR heater system
(4)	10	Nox sensor, SCR tank sensor
(5)	10	EGR valve air flow sensor
(6)	10	Spare fuse
(7)	30	Spare fuse

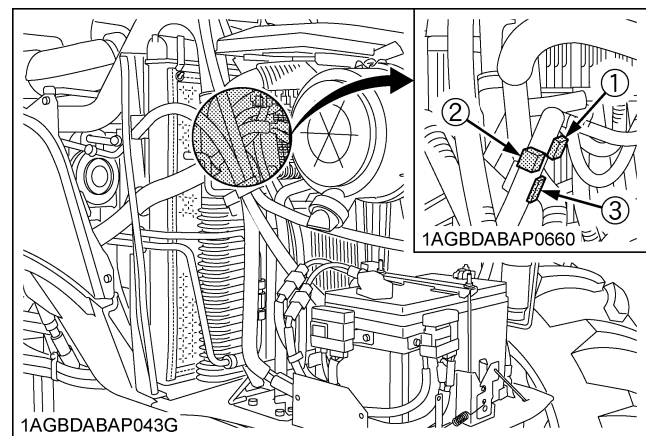

[Oil separator Fuse] (if equipped)

Fuse No.	Capacity (A)	Protected circuit
(1)	15	Heater (Oil separator, OUT 1)
(2)	15	Heater (Oil separator, IN)
(3)	15	Heater (Oil separator, OUT 2)

■ Replacing Slow-Blow Fuses

The slow-blow fuses are intended to protect the electrical cabling. If any of them has blown out, be sure to pinpoint the cause. Never use any substitute, use only a KUBOTA genuine part.

[M5N-091, M5N-111]

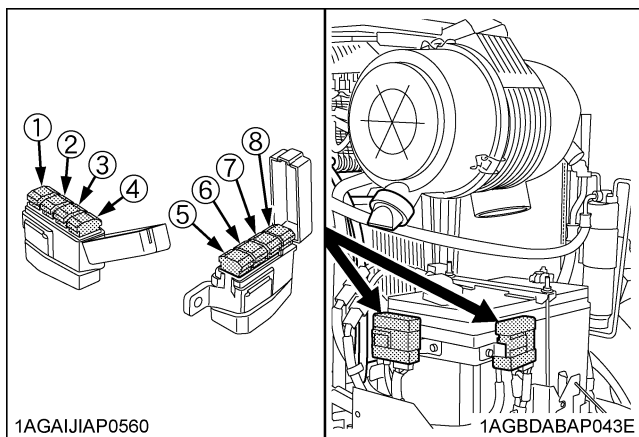

[B Type]

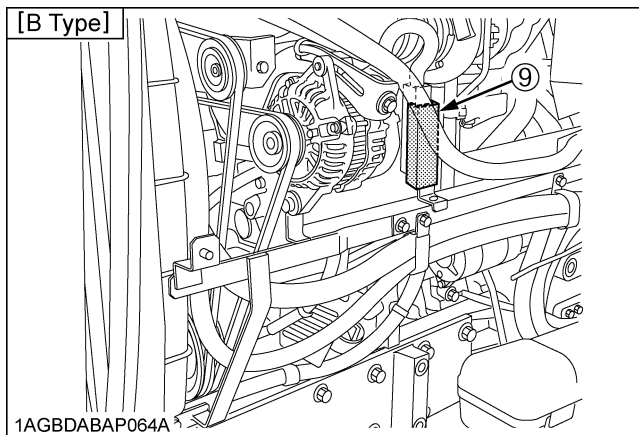

[M4N-071]

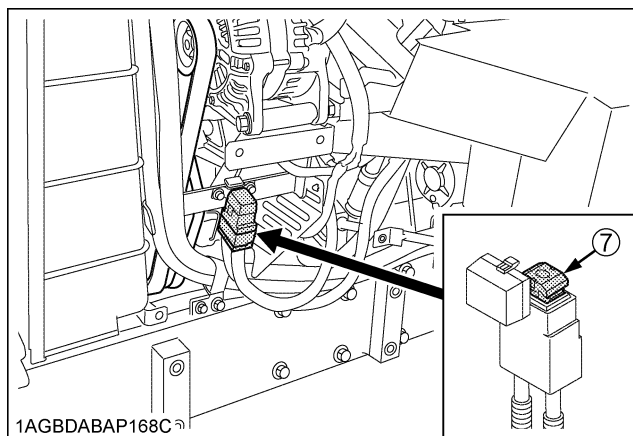
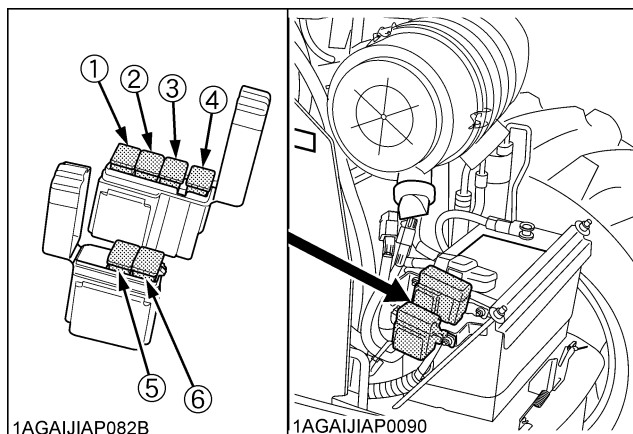

No.	Capacity	Protected circuit	Type
1	120A	Engine preheat	Bolt fixed
2	30A	Work light	
3	30A	Electrical outlet	Non Bolt fixed
4	50A	Starter, Air conditioner	
5	50A	Head lamp, Hazard	Bolt fixed
6	30A	Main key switch	
7	140A	Charge	

No.	Capacity	Protected circuit	Type
1	30A	Main key switch	Bolt fixed
2	100A	Charge	
3	50A	SCR system	Non Bolt fixed
4	60A	Defogger, Hazard	
5	120A	Engine preheat	Bolt fixed
6	30A	Work light	
7	30A	Electrical outlet	Non Bolt fixed
8	60A	Starter, Air conditioner	
9	150A	Charge [B type only]	

◆ Replacement procedure

[Non bolt fixed slow-blow fuse:]

1. Disconnect the negative cord of the battery.
2. Pull out the fuse from the fuse box.
3. Replace with a new one of the same capacity.

[Bolt fixed slow-blow fuse:]

Consult your local KUBOTA Dealer for this service.

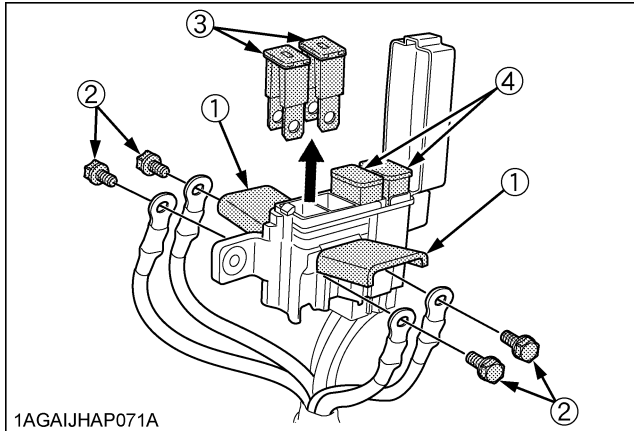

1AGAIJHAP071A

- (1) Fuse box
- (2) Bolt
- (3) Bolt fixed slow-blow fuse
- (4) Non bolt fixed slow-blow fuse

■ Replacing Light Bulb

Light	Capacity
Head light	12 V, 55 / 60 W (H4)
Hazard light	12 V, 21 W
Turn signal	12 V, 21 W
Tail light	12 V, 5 W
Work light (for outer roof)	12 V, 55 W
Front work light	12 V, 35 W
Dome light (Room lamp)	12 V, 5 W

■ Replacing Head Lamp

CAUTION

To avoid personal injury:

- Be careful not to drop the bulb, hit anything against the lamp, apply excess force, and get the lamp scratched. If broken, glass may cause injury. Pay more attention to halogen lamps in particular, which have high pressure inside.
- Before replacing the lamp, be sure to turn off the light and wait until the bulb cools down, otherwise, you may get burned.

1. While pushing the right and left lock buttons, pull and remove the electrical connector.
2. Turn the cover counterclockwise to remove it.
3. Turn the bulb base counterclockwise to take out the bulb.
4. Replace with a new bulb and reinstall the head lamp assembly in the reverse order.

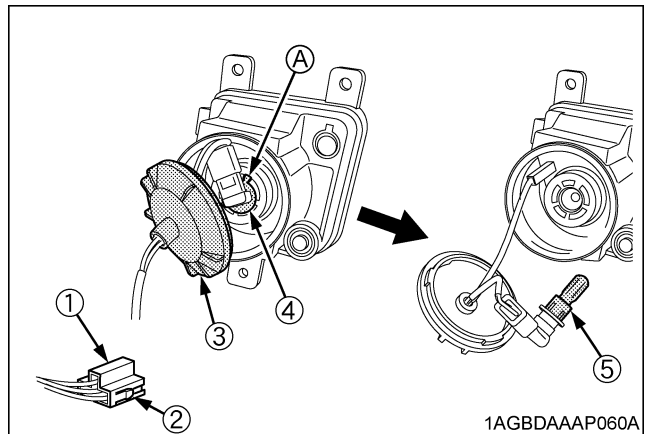

1AGBDAAP060A

- (1) Electrical connector
- (2) Lock buttons
- (3) Cover
- (4) Bulb base
- (5) Bulb
- (A) "Base's wider projection to face upward"

IMPORTANT :

- Be sure to use a new bulb of the specified wattage.
- Never touch the bulb surface (glass) with bare hands. Fingerprints, for example, may break the bulb.

■ **Lubricating Points**

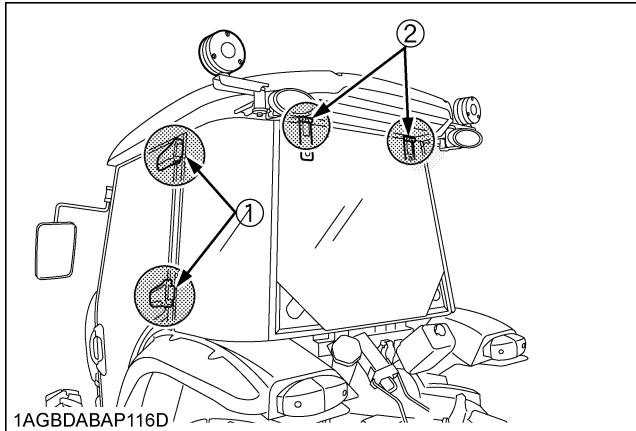

- (1) Door hinge
- (2) Rear window hinge

■ **Adding Washer Liquid**

Add a proper amount of automobile washer liquid.

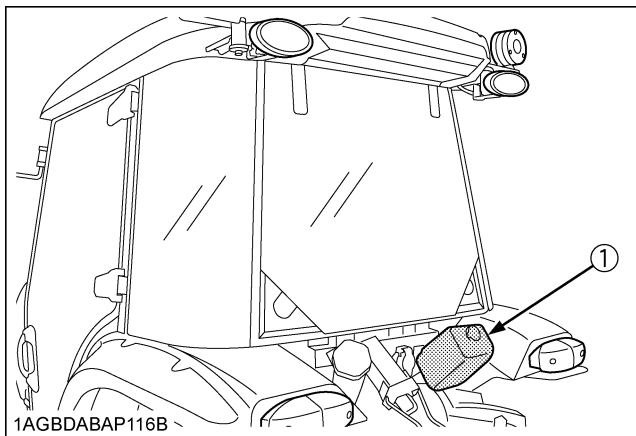

- (1) Washer liquid tank

Washer tank capacity	2.0 L (2.1 U.S.qts.)
----------------------	----------------------

■ **Checking the Amount of Refrigerant (gas)**

! WARNING

To avoid personal injury or death:

- Liquid contact with eyes or skin may cause frostbite.
- In the event of a leakage, wear safety goggles. Escaping refrigerant can cause severe injuries to eyes.
- In contact with a flame, R134a refrigerant gives a toxic gas.
- Do not disconnect any part of the refrigeration circuit of the air conditioning system. Consult your local KUBOTA Dealer for assistance and service.

A shortage of refrigerant impairs the air-conditioner performance. Check the following points. If it is indicated that the amount of refrigerant is extremely low, ask your dealer to inspect and charge.

◆ **Checking procedure**

1. Run the air-conditioner in the following conditions.
 - Engine speed: About 1500 rpm
 - Temperature control dial: Maximum cooling position
 - Fan switch: Highest blow (HI)
 - Air-conditioner switch: ON
2. Look into the sight glass to see if the refrigerant is flowing through its circuit.

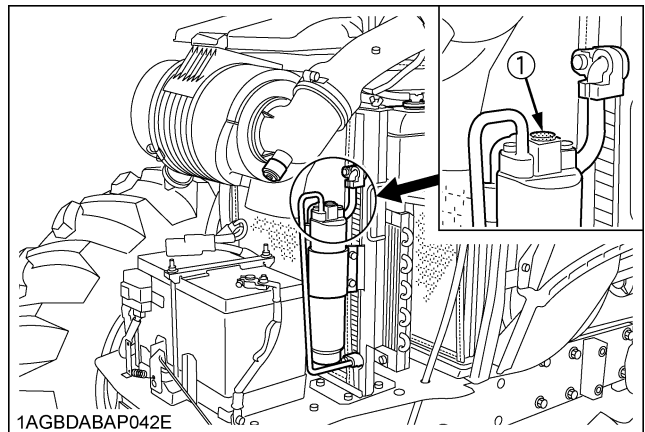

- (1) Sight glass

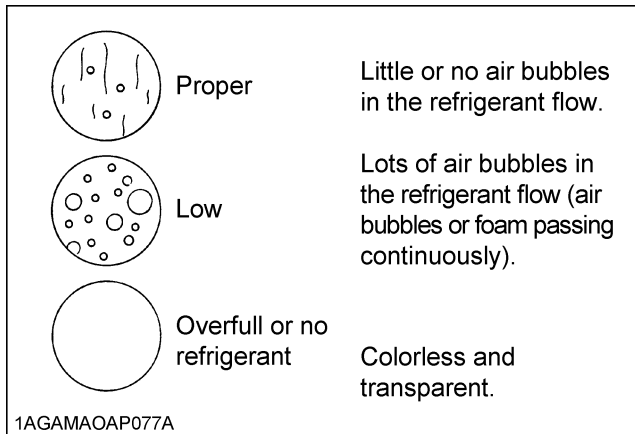
**IMPORTANT :**

- Charge only with R134a not R12 refrigerant (gas).

STORAGE



WARNING

To avoid personal injury or death:

- Do not clean the machine while the engine is running.
- To avoid the danger of exhaust fume poisoning, do not operate the engine in a closed building without proper ventilation.
- When storing, remove the key from the key switch to avoid unauthorized persons from operating the tractor and getting injured.

TRACTOR STORAGE

If you intend to store your tractor for an extended period of time, follow the procedures outlined below.

These procedures will insure that the tractor is ready to operate with minimum preparation when it is removed from storage.

1. Check the bolts and nuts for looseness, and tighten if necessary.
2. Apply grease to tractor areas where bare metal will rust also to pivot areas.
3. Detach the weights from the tractor body.
4. Inflate the tires to a pressure a little higher than usual.
5. Change the engine oil and run the engine to circulate oil throughout the engine block and internal moving parts for about 5 minutes.
6. Keep the PTO clutch control switch or lever at "DISENGAGE" position while tractor is stored for a long period of time.
7. With all implements lowered to the ground, coat any exposed hydraulic cylinder piston rods with grease.
8. Remove the battery from the tractor. Store the battery following the battery storage procedures.
(See "Checking Battery Condition" in "EVERY 100 HOURS" in "PERIODIC SERVICE" section.)
9. Preferably let the DEF/AdBlue® out of its tank and store the fluid in another specific tank.
For a long-term storage of DEF/AdBlue®, refer to "Storing and Handling the DEF/AdBlue®" in "SELECTIVE CATALYTIC REDUCTION (SCR) MUFFLER" in "OPERATING THE ENGINE" section.
10. Keep the tractor in a dry place where the tractor is sheltered from the elements. Cover the tractor.
11. Store the tractor indoors in a dry area that is protected from sunlight and excessive heat. If the tractor must be stored outdoors, cover it with a waterproof tarpaulin. Jack the tractor up and place blocks under the front and rear axles so that all 4 tires are off the ground. Keep the tires out of direct sunlight and extreme heat.

IMPORTANT :

- When washing the tractor, be sure to stop the engine. Allow sufficient time for the engine to cool before washing.
- Cover the tractor after the muffler and the engine have cooled down.

REMOVING THE TRACTOR FROM STORAGE

1. Check the tire air pressure and inflate the tires if they are low.
2. Jack the tractor up and remove the support blocks from under the front and rear axles.
3. Install the battery. Before installing the battery, be sure it is fully charged.
4. Check the fan belt tension.
5. Check all fluid levels (engine oil, transmission/hydraulic oil, engine coolant, DEF/AdBlue® and any attached implements).
6. Start the engine. Observe all gauges. If all gauges are functioning properly and reading normal, move the tractor outside. Once outside, park the tractor and let the engine idle for at least 5 minutes. Shut the engine off and walk around tractor and make a visual inspection looking for evidence of oil or water leaks.
7. With the engine fully warmed up, release the parking brake and test the brakes for proper adjustment as you move forward. Adjust the brakes as necessary.

NOTE :

- The information regarding DEF/AdBlue® corresponds only to the M5N-091 and M5N-111 tractor models.

TROUBLESHOOTING

ENGINE TROUBLESHOOTING

If something is wrong with the engine, refer to the table below for the cause and its corrective measure.

Trouble		Cause	Countermeasure
Engine is difficult to start or won't start.		<ul style="list-style-type: none"> No fuel flow. 	<ul style="list-style-type: none"> Check the fuel tank and the fuel filter. Replace filter if necessary.
		<ul style="list-style-type: none"> Air or water is in the fuel system. 	<ul style="list-style-type: none"> Check to see if the fuel line coupler bolt and nut are tight. Bleed the fuel system (See "Bleeding Fuel System" in "SERVICE AS REQUIRED" in "PERIODIC SERVICE" section.)
		<ul style="list-style-type: none"> In winter, oil viscosity increases, and engine revolution is slow. 	<ul style="list-style-type: none"> Use oils of different viscosities, depending on ambient temperatures. Use engine block heater (Optional)
		<ul style="list-style-type: none"> Battery becomes weak and the engine does not turn over quick enough. 	<ul style="list-style-type: none"> Clean battery cables & terminals. Charge the battery. In cold weather, always remove the battery from the engine, charge and store it indoors. Install it on the tractor only when the tractor is going to be used.
		[M4N-071] <ul style="list-style-type: none"> Preheat (glow plug) system trouble. 	<ul style="list-style-type: none"> Check to see if the slow blow fuse of the preheat (glow plug) blows. Check to see if the preheat (glow plug) functions in cold weather.
		[M5N-091, M5N-111] <ul style="list-style-type: none"> Intake air heater system trouble. 	<ul style="list-style-type: none"> Check to see if the slow blow fuse of the intake air heater blows. Check to see if the intake air heater functions in cold weather.
Insufficient engine power.		<ul style="list-style-type: none"> Insufficient or dirty fuel. The air cleaner is clogged. 	<ul style="list-style-type: none"> Check the fuel system. Clean or replace the element.
		[M5N-091, M5N-111] <ul style="list-style-type: none"> DEF/AdBlue® runs short 	<ul style="list-style-type: none"> Add DEF/AdBlue®.
Engine stops suddenly.		<ul style="list-style-type: none"> Insufficient fuel. 	<ul style="list-style-type: none"> Refuel. Bleed the fuel system if necessary.
Exhaust fumes are colored.	Black	<ul style="list-style-type: none"> Fuel quality is poor. Too much oil. The air cleaner is clogged. 	<ul style="list-style-type: none"> Change the fuel and fuel filter. Check the proper amount of oil. Clean or replace the element.
	Blue white	<ul style="list-style-type: none"> The inside of exhaust muffler is damp with fuel. Injection nozzle trouble. Fuel quality is poor. 	<ul style="list-style-type: none"> Check to see if the intake air heater functions in cold weather. Heat the muffler by applying load to the engine. Check the injection nozzle. Change the fuel and fuel filter.

Trouble	Cause	Countermeasure
Engine overheats	● Engine overloaded	● Shift to lower gear or reduce load.
	● Low coolant level	● Fill cooling system to the correct level; check radiator and hoses for loose connections or leaks.
	● Loose or defective fan belt	● Adjust or replace fan belt.
	● Dirty radiator core or grille screens	● Remove all trash.
	● Coolant flow route corroded	● Flush cooling system.

If you have any questions, contact your local KUBOTA Dealer.

Trouble	Operator's action
Engine not overheated, but engine warning indicator on.	<p>Stop the engine and get it restarted. If the engine fails to restart or the indicator stays on, immediately contact your local KUBOTA dealer. If the warning indicator lights up, the following phenomena may appear depending on the engine's trouble spot.</p> <ul style="list-style-type: none"> ● The engine stops unexpectedly. ● The engine fails to start or gets interrupted just after start. ● The engine output is not enough. ● The engine output is enough, but the warning indicator stays on.

If you have any questions, contact your local KUBOTA Dealer.

POWER TRAIN TROUBLE SHOOTING

If something is wrong with the power train, the master system warning indicator starts blinking and the error code shown below is displayed on the liquid crystal display, indicating the location of the trouble. If an error code appears, immediately contact your local KUBOTA Dealer for repairs.

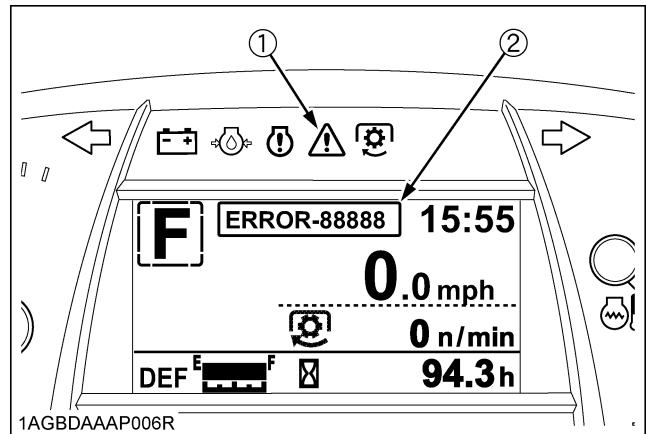

(1) Master system warning indicator

(2) Error code

Displayed error code	Trouble
ERROR-1	Acceleration sensor (main) trouble
ERROR-2	Acceleration sensor (sub) trouble
ERROR-3	Acceleration sensor main/sub phase shifting trouble
ERROR-4	Shuttle sensor (main) trouble
ERROR-5	Shuttle sensor (sub) trouble
ERROR-6	Shuttle sensor main/sub phase shifting trouble
ERROR-7	Shuttle sensor signal trouble
ERROR-8	Gear lock signal trouble
ERROR-11	PTO relay trouble
ERROR-12	4-wheel-drive solenoid trouble
ERROR-13	Bi-speed turn solenoid trouble
ERROR-14	Shuttle forward solenoid trouble
ERROR-15	Shuttle reverse solenoid trouble
ERROR-21	Range gear shift (Hi) switch trouble
ERROR-22	Main gear shift (6th) switch trouble
ERROR-23	Shuttle rotating sensor trouble
ERROR-24	Machine speed sensor trouble
ERROR-ENG (ERROR-41)	Engine communication trouble
ERROR-ACU (ERROR-42)	ACU communication trouble
ERROR-ECU (ERROR-43)	ECU communication trouble or meter communication trouble
ERROR-60	Analog reference supply voltage +5V trouble
ERROR-63	Acceleration & engine adjustment trouble
ERROR-NET	Communication trouble

OPTIONS

Consult your local KUBOTA Dealer for further details.

- Engine Block Heater
For extremely cold weather starting
- Front end weights
For front ballast
- Front end weights and bracket
For front ballast
- Rear Wheel Weights
For rear ballast
- Rear Cast Iron Disk
- Creep Speed Kit
- Double Acting Remote Hydraulic Control Valve with Detente, Self-Cancelling and Flow Control Functions
- Double Acting Remote Hydraulic Control Valve with Flow Position and Flow Control Functions
- Single/Double Acting Valve
- Single/Double Acting Remote Hydraulic Control Valve with Flow Control Functions
- Remote valve lever kit
- Clevis for Drawbar
- Defogger Kit
- 130A Alternator Kit
- Rear Window Wiper Kit with Washer
- Radio with CD player

MOUNTING THE SUPPORT PLATE

■ Installation Procedures

1. Insert the support plate through the CD player mounting opening of the inner roof.

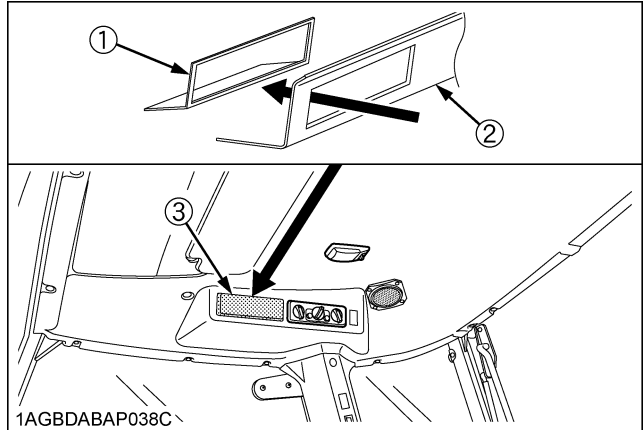

- (1) Support plate
- (2) Inner roof
- (3) CD player mounting opening

2. Insert the mounting collar into the inner roof and support plate.

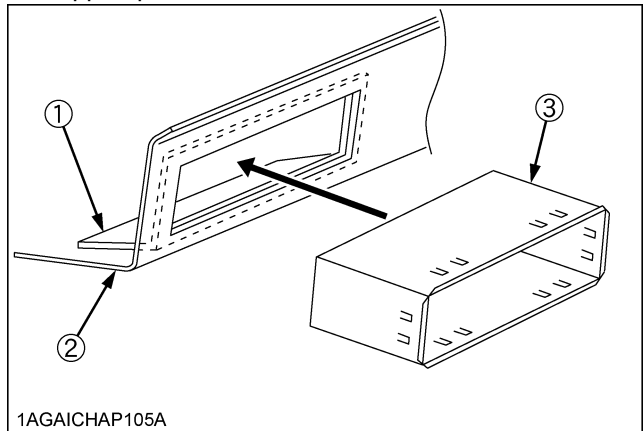

- (1) Support plate
- (2) Inner roof
- (3) Mounting collar

3. Bend the mounting tabs of the mounting collar out with a screwdriver.

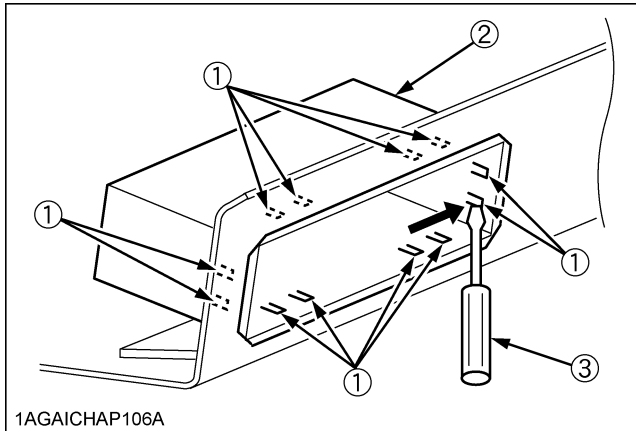

- (1) Mounting tabs
 (2) Mounting collar
 (3) Screwdriver

4. Connect the antenna lead to the CD player.
 5. Connect the power connector to the CAB wire harness.

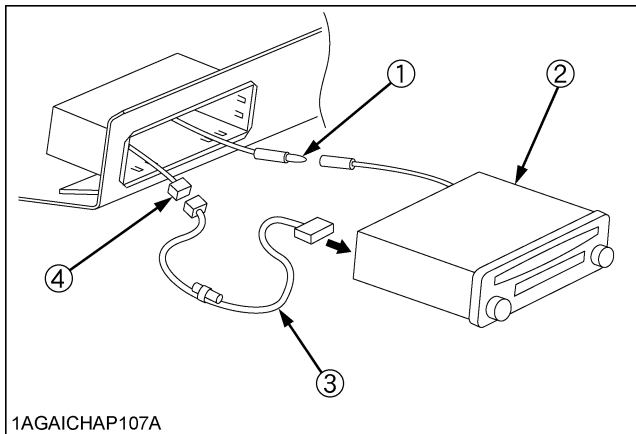

- (1) Antenna lead
 (2) CD player
 (3) Power connector
 (4) CAB wire harness

6. Insert the CD player into the mounting collar and push it in until "click" is heard. (The CD player is secured to the mounting collar by the side tabs.)

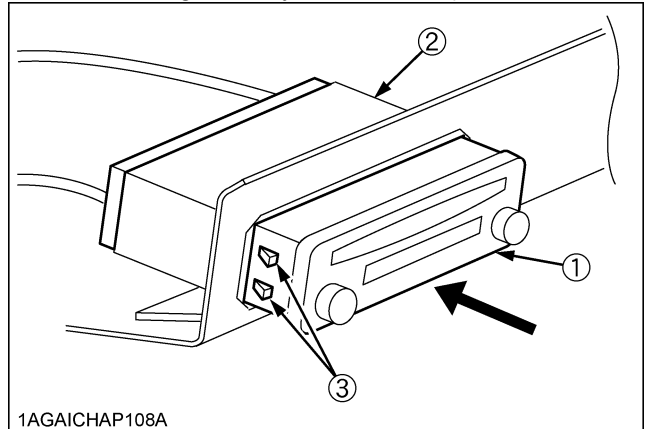

1AGAICHAP108A

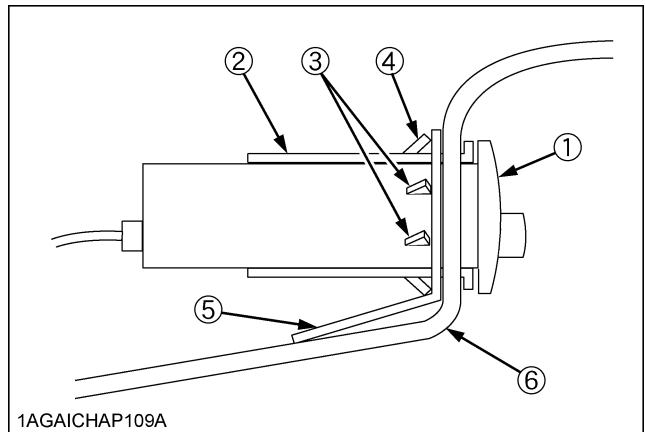

1AGAICHAP109A

- (1) CD player
 (2) Mounting collar
 (3) Side tabs
 (4) Mounting tabs
 (5) Support plate
 (6) Inner roof

APPENDICES

INDEX

3-point Hitch Lowering Speed	68	DPF Differential Pressure Sensor Hose	125
4WD / Bi-speed Turn Switch	43	DPF Differential Pressure Sensor Pipe	125
Air Cleaner Primary Element.....	103	DPF Muffler	124
Air Cleaner Primary Element and Secondary Element.....	121	DPF Regeneration Process	15
Air Conditioner Hose	126	DPF/SCR Muffler	100
Air Conditioner Pipe and Hose	119	Draft Control	67
Air Control Vent	82	Drawbar	62
Air-Conditioner Belt Tension	108	Drawbar Length	66
Airflow.....	82	Dual Exhaust Aftertreatment Devices.....	14
Amount of Refrigerant (gas)	132	Dual Speed Shift Switch	41
Anti-Freeze.....	123	Dual Tires	73
Antifrost Heater for Oil Separator	125	Dust Indicator	98
Battery Condition.....	106	Easy Checker(TM).....	45
Block Heater (if equipped).....	30	EGR Cooler	122
Boost Sensor Hose	125	EGR Cooler Hose	125
Brake Hose.....	119	EGR Pipe.....	125
Brake Hose.....	126	EGR System.....	124
Brake Pedal.....	100	Electrical Outlet	87
Brake Pedal.....	105	Engine Filter	101
Brake Pedals (Right and Left)	37	Engine Low Temperature Regulation	31
Brake Seal 1 and 2.....	126	Engine Oil	101
Brake System	127	Engine Oil	112
CAB Isolation Cushion	125	Engine Oil Filter	113
Checking and Refueling	94	Engine Oil Level	96
Clutch Housing Water	127	Engine Over-speed Limiting Indicator	44
Clutch Off Switch.....	42	Engine Start System.....	101
Clutch Pedal	39	Engine Valve Clearance	121
Constant RPM Management Control	55	Equalizer Kit	126
Control Panel.....	84	Evacuator Valve	98
Coolant Level	97	Exhaust Manifold	121
Coolant Temperature Gauge.....	47	Fan Belt Tension	104
Cooling System and Coolant.....	122	Float Control	68
Creep Speed (if equipped)	42	Flow rate.....	70
DEF / AdBlue® Gauge	47	Foot Throttle	44
DEF/AdBlue®.....	22	Fresh Air Filter	110
DEF/AdBlue® Freeze Warning	31	Front Axle Gear Case Oil & Front Differential Case Oil	120
DEF/AdBlue® injector	124	Front Axle Pivot	119
DEF/AdBlue® Injector Tip.....	121	Front Ballast	76
DEF/AdBlue® level and the fluid.....	95	Front Wheels (with 4-wheel drive).....	74
DEF/AdBlue® Line	121	Front Wiper / Washer Switch	81
DEF/AdBlue® Pump Filter	125	Front Work Light.....	80
Differential Lock.....	56	Fuel Filter.....	114
Do not Operate the Tractor at Full Speed for the First 50 Hours.....	34	Fuel Gauge.....	46
Dome Light.....	79	Fuel Hose	126
Door.....	78	Fuel Injector Nozzle Tip.....	121
		Fuel Line.....	117
		Fuel Solenoid Pump Element.....	112

Fuel System	126	Operator's Seat.....	34
Fuel Tank Water.....	110	Outline of the SCR.....	21
Fuse	128	Parking	55
Gauges, Meter and Easy Checker(TM).....	100	Parking Brake Cable.....	125
Gear Locked Parking Brake	106	Parking Brake Lever	39
Grill, Radiator and Cooler.....	98	PCV (Positive Crankcase Ventilation) Valve	122
Hand Throttle Lever.....	44	Performance Monitor	52
Handling Points	15	Position Control	67
Head Lamp.....	131	Power Steering	57
Head Light, Turn Signal / Hazard Light etc.	100	Power Steering Hose.....	126
Holes of Lower Links	62	Power Steering Line	115
Hood.....	93	PTO Clutch Control Switch.....	58
Horn Button	37	PTO Gear Shift Lever	59
Hydraulic Control Unit Use Reference Chart..	72	PTO Shaft Cover and Shaft Cap	60
Hydraulic Oil Filter	114	PTO Speed Limiter	59
Immediately Stop the Engine if:.....	44	Radiator Hose (Water pipes)	126
Inflation Pressure	73	Radiator Hose and Clamp	116
Inner Air Filter.....	110	Range Gear Shift Lever.....	41
Installation Procedures.....	138	Rear Ballast	77
Intake Air Heater	124	Rear Turn Signal / Hazard Light	37
Intake Air Line	118	Rear Wheels.....	75
Intake Air Line	126	Rear Window	79
LCD Monitor Message.....	60	Rear Wiper / Washer Switch (if equipped)....	81
Lift Cylinder Hose	119	Rear Work Light.....	80
Lift Cylinder Hose	126	Remote Control Valve	69
Lifting Rod (Left).....	63	Remote Control Valve Coupler	
Lifting Rod (Right)	63	Connecting and Disconnecting.....	70
Light Bulb	131	Remote Control Valve Lever	69
Light Switch	36	RPM Dual Memory Setting	53
Lubricating Grease Fittings	102	Safe Replacement of the Wheel.....	73
Lubricating Oil for New Tractors.....	34	Seat Belt	35
Lubricating Points.....	132	Seat Belt	100
Main Gear Shift Lever	41	Shuttle Shift Lever	41
Maintenance Items Chart	90	Side Cover.....	94
Master Cylinder Filter	125	Side Window.....	79
Master Cylinder Kit	126	Slow-Blow Fuses	130
Mixed Control	68	Stabilizer	64
Movable Parts	100	Stopping	44
Muffler	35	Storing and Handling DEF/AdBlue®.....	27
Oil Cooler Line.....	126	Supply Pump	124
Oil Separator Element.....	121	Tachometer	47
Oil Separator Hose.....	125	Tie-rod Dust Cover	102
Opening the Door	78	Tilt Steering Adjustment	35
Operating on Slopes and Rough Terrain.....	57	Tips on Diesel Particulate Filter (DPF)	
Operating Procedure		Regeneration	21
for Auto Regeneration Mode	16	Toe-in	109
Operating Procedure		Top Link.....	64
for Parked Regeneration	20	Top Link Mounting Holes.....	62
Operating Procedure		Trailer Electrical Outlet	57
for Regeneration Inhibit Mode	18	Transmission Fluid	120
Operating the Tractor on a Road.....	56	Transmission Fluid Level.....	97
Operation.....	84	Transport the Tractor Safely.....	57

Travel Speed Limiter	40
Turbocharger	124
Turn Signal / Hazard Light Switch	36
Various Setting Mode	49
Walk Around Inspection	94
Warm-up and Transmission Oil at Low Temperature Range.....	32
Warning Indication and its Countermeasure ..	22
Washer Liquid	132
Water Separator	96
Water Separator	111
Wheel Bolt Torque.....	102
Wipers in Cold Season.....	81
Work Light Switch.....	80