

# Kubota

- U.S.A. : **KUBOTA TRACTOR CORPORATION**  
1000 Kubota Drive, Grapevine, TX 76051  
Telephone : 888-4KUBOTA
- Canada : **KUBOTA CANADA LTD.**  
5900 14th Avenue, Markham, Ontario, L3S 4K4, Canada  
Telephone : (905)294-7477
- France : **KUBOTA EUROPE S.A.S**  
19-25, Rue Jules Verccruysse, Z.I. BP88, 95101 Argenteuil Cedex, France  
Telephone : (33)1-3426-3434
- Italy : **KUBOTA EUROPE S.A.S Italy Branch**  
Via Grandi, 29 20068 Peschiera Borrome (MI) Italy  
Telephone : (39)02-51650377
- Germany : **KUBOTA BAUMASCHINEN GmbH**  
Steinhauser str, 100, 66482 Zweibrucken Rheinlandpfalz Germany  
Telephone : (49)6332-4870100
- U.K. : **KUBOTA (U.K.) LTD.**  
Dormer Road, Thame, Oxfordshire, OX9 3UN, U.K.  
Telephone : (44)1844-214500
- Australia : **KUBOTA TRACTOR AUSTRALIA PTY LTD.**  
25-29 Permas Way, Truganina, VIC 3029, Australia  
Telephone : (61)-3-9394-4400
- Malaysia : **SIME KUBOTA SDN. BHD.**  
No.3 Jalan Sepadu 25/123 Taman Perindustrian Axis,  
Seksyen 25, 40400 Shah Alam, Selangor Darul Ehsan Malaysia  
Telephone : (60)3-736-1388
- Philippines : **KUBOTA PHILIPPINES, INC.**  
232 Quirino Highway, Baesa, Quezon City 1106, Philippines  
Telephone : (63)2-422-3500
- Taiwan : **SHIN TAIWAN AGRICULTURAL MACHINERY CO., LTD.**  
16, Fengping 2nd Rd, Taliao Shiang Kaohsiung 83107, Taiwan R.O.C.  
Telephone : (886)7-702-2333
- Thailand : **SIAM KUBOTA CORPORATION CO., LTD.**  
101/19-24 Moo 20, Navanakorn Industrial Estate, Tambon Khlongnueng, Amphur Khlongluang,  
Pathumthani 12120, THAILAND  
Telephone : (66)2-909-0300
- Japan : **KUBOTA Corporation**  
Farm & Industrial Machinery International Operations Headquarters  
2-47, Shikitsuhigashi 1-chome, Naniwa-ku, Osaka, Japan 556-8601

AV. I. 1-1. - K

English (U.S.A.)  
Code No. RH418-8193-1

U  
2  
7  
-  
4

## OPERATOR'S MANUAL

# KUBOTA EXCAVATOR

MODEL **U**<sub>27-4</sub>

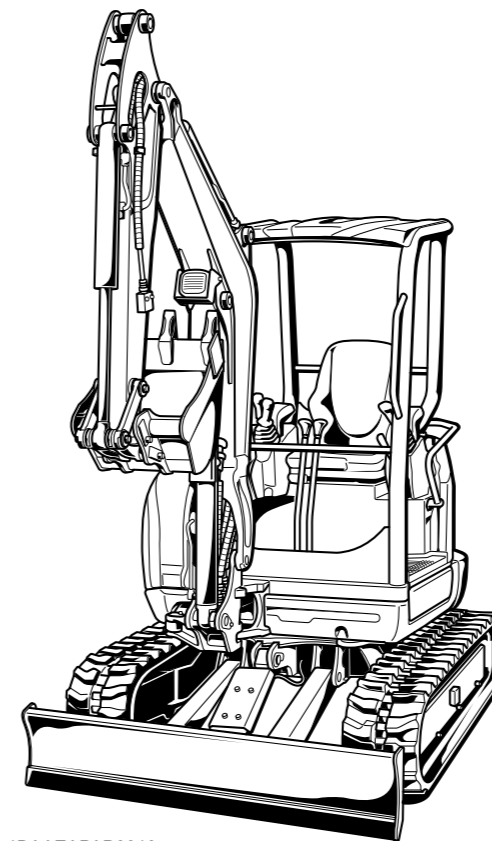

1BAAEAPAP0010

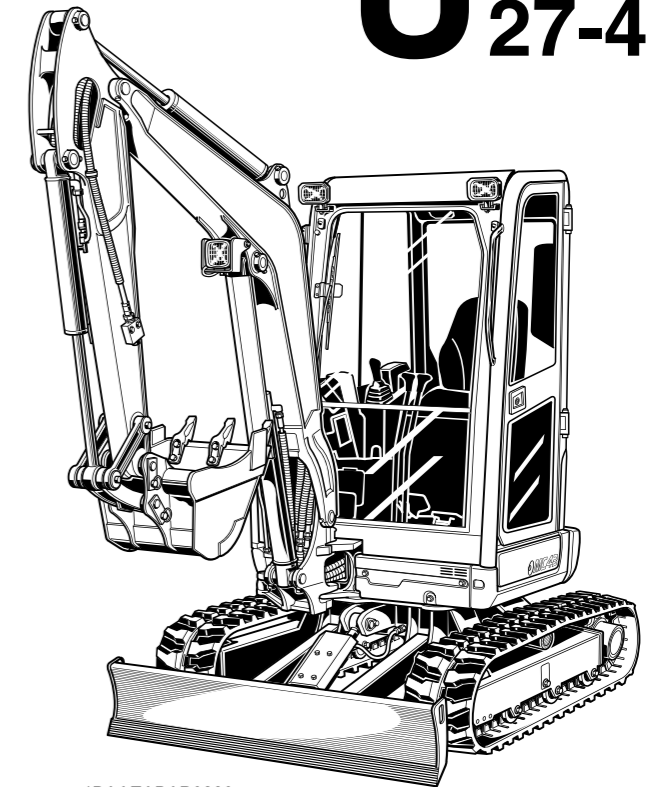

1BAAEABAP0280

READ AND SAVE THIS MANUAL

Kubota

# ABBREVIATION LIST

| Abbreviations | Definitions   |
|---------------|---|
| AI            | Auto Idle   |
| API           | American Petroleum Institute  |
| ASTM          | American Society for Testing and Materials, USA                                   |
| CECE          | Committee for European Construction Equipment                                     |
| DIN           | Deutsches Institut für Normung, GERMANY<br>(German Institute for Standardization) |
| EN            | European Standard   |
| FRONT         | "Front" means the direction towards the boom and dozer                            |
| Hi            | High speed  |
| ISO           | International Organization for Standardization                                    |
| JIS           | Japanese Industry Standard  |
| L             | Volume (Liter)  |
| L/min         | Liter per minute  |
| Lo            | Low speed   |
| MIL           | Military Standard   |
| OPG           | Operator Protective Guards  |
| OSHA          | Occupational Safety and Health Administration                                     |
| ROPS          | Roll-Over Protective Structure  |
| rpm           | Revolutions Per Minute  |
| SAE           | Society of Automotive Engineers, USA  |
| TPSS          | Two Pattern Selection System  |

## California Proposition 65

### **WARNING**

Engine exhaust, some of its constituents, certain vehicle components and fluids, contain or emit chemicals known to the State of California to cause cancer and birth defects or other reproductive harm.

### **IMPORTANT**

The engine in this machine is not equipped by the manufacturer with a standard spark arrester.  
It is a violation of California Public Resource Code Section 4442 to Use or operate this engine on or near any forest-covered, brush-covered land, or grass-covered land unless the exhaust system is equipped with a working spark arrester meeting state laws. Other states or federal areas may have similar laws.

# GENERAL SYMBOLS

The instruments and operation elements have been marked with a series of symbols in order to simplify the operation of your excavator. These symbols are listed below with the respective descriptions.

|   |                         |   |                                    |
|---|-------------------------|---|------------------------------------|
|    | Warning light           |    | Read operator's manual             |
|    | Fuel indicator          |    | Bolted                             |
|    | Engine oil indicator    |    | Released                           |
|    | Charge indicator        |    | Rotary beacon                      |
|    | Glow indicator          |    | Display selector switch            |
|    | Working lights          |    | Menu button                        |
|    | Horn                    |    | Auxiliary port indicator           |
|    | Hydraulic oil           |    | Service interval indicator         |
|    | Travel speed            |    | Set clock indicator                |
|    | Low speed               |    | Indicator coolant temperature      |
|   | Forward travel          |   | Fan                                |
|  | Backward travel         |  | Indirect return flow               |
|  | Raise boom              |  | Direct return flow                 |
|  | Lower boom              |  | System lamp                        |
|  | Arm crowd               |  | Warning lamp "Auto Idle (AI) Lamp" |
|  | Arm dump                |  | Diesel                             |
|  | Bucket crowd            |  | Gear oil                           |
|  | Bucket dump             |  | Grease                             |
|  | Swivel boom (left)      |  | Engine stop control lamp           |
|  | Swivel boom (right)     |  | Working light switch               |
|  | Dozer up                |   |                                    |
|  | Dozer down              |   |                                    |
|  | Lever direction         |   |                                    |
|  | Control lever direction |   |                                    |

# FOREWORD

You are now the proud owner of a KUBOTA Excavator. This excavator is a product of KUBOTA quality engineering and manufacturing. It is made of fine materials and under a rigid quality control system. It will give you long, satisfactory service. To obtain the best use of your excavator, please read this manual carefully. It will help you become familiar with the operation of the excavator and contains many helpful hints about excavator maintenance. It is KUBOTA's policy to utilize as quickly as possible every advance in our research. The immediate use of new techniques in the manufacture of products may cause some small parts of this manual to be outdated. KUBOTA distributors and dealers will have the most up-to-date information. Please do not hesitate to consult with them.

## SAFETY FIRST

This symbol, the industry's "Safety Alert Symbol", is used throughout this manual and on labels on the machine itself to warn of the possibility of personal injury. Read these instructions carefully. It is essential that you read the instructions and safety regulations before you attempt to assemble or use this unit.



**DANGER :** Indicates an imminently hazardous situation which, if not avoided, will result in death or serious injury.



**WARNING :** Indicates a potentially hazardous situation which, if not avoided, could result in death or serious injury.



**CAUTION :** Indicates a potentially hazardous situation which, if not avoided, could result in minor or moderate injury.

**IMPORTANT :** Indicates that equipment or property damage could result if instructions are not followed.

**NOTE :** Gives helpful information.

# CONTENTS

|  |     |
|--|-----|
| ▲SAFE OPERATION .....  | ▲-1 |
| DEALER SERVICE.....  | 1   |
| TECHNICAL DATA.....  | 3   |
| DESCRIPTION OF MACHINE PARTS.....  | 4   |
| INSTRUMENT PANEL AND CONTROL ELEMENTS.....   | 5   |
| CHECKS BEFORE START .....  | 8   |
| DAILY CHECKS.....  | 8   |
| CAB TYPE MACHINES .....  | 8   |
| Wiper/Washer Switch .....  | 8   |
| Interior Lamp.....   | 8   |
| Working Light Switch .....   | 9   |
| Heater Switch .....  | 9   |
| Opening/Closing of CAB Door .....  | 10  |
| Opening/Closing of Front CAB Window.....   | 10  |
| Opening/Closing of Side CAB Window.....  | 11  |
| Emergency Hammer.....  | 11  |
| HANDLING THE SAFETY DEVICES.....   | 11  |
| Pilot Control Lock Lever.....  | 11  |
| OPERATION OF THE ENGINE.....   | 12  |
| STARTING THE ENGINE .....  | 12  |
| Display Selector Switch .....  | 13  |
| Battery Charge Lamp.....   | 15  |
| Engine Oil Pressure Warning Lamp .....   | 15  |
| Glow Lamp.....   | 15  |
| LCD for Normal Operation .....   | 16  |
| LCD for Warning.....   | 17  |
| Warning Lamp .....   | 17  |
| Checkpoints after Starting the Engine .....  | 18  |
| STARTING THE ENGINE UNDER COLD CONDITIONS.....                                       | 18  |
| Precautions in case of Overheat.....   | 18  |
| STOPPING THE ENGINE.....   | 19  |
| Engine Stop Button.....  | 19  |
| STARTING WITH AN AUXILIARY BATTERY .....   | 19  |
| Observe Following Guidelines when Starting with an Auxiliary Battery.....            | 19  |
| EXCAVATOR OPERATION .....  | 21  |
| RUNNING-IN OF THE NEW EXCAVATOR.....   | 21  |
| Do not Work with Full Engine Rpm's or Full Loads during the First 50 Working Hours.. | 21  |
| Oil Change in the Run-in Stage .....   | 21  |
| Seat Belt .....  | 21  |
| STARTING .....   | 21  |
| Operator's Seat.....   | 21  |
| Pilot Control Lock Lever.....  | 22  |
| Working Light Switch .....   | 22  |

|  |    |
|--|----|
| Travel Buzzer.....   | 22 |
| Beacon Light Switch .....                                    | 22 |
| TWO PATTERN SELECTION SYSTEM (TPSS).....                     | 23 |
| Pattern Change.....  | 23 |
| OPERATION OF THE BOOM.....                                   | 24 |
| OPERATION OF THE ARM.....                                    | 24 |
| OPERATION OF THE BUCKET .....                                | 25 |
| SWIVEL(UNIT SWING)OPERATION .....                            | 25 |
| BOOM SWING OPERATION.....                                    | 25 |
| OPERATION OF THE DOZER .....                                 | 26 |
| AUX PORT OPERATION.....                                      | 26 |
| One-way Hold Switch .....                                    | 27 |
| DRIVING .....  | 28 |
| Drive Levers (Right, Left).....                              | 29 |
| Throttle Lever.....  | 29 |
| Travel Speed Switch.....                                     | 30 |
| TURNS.....   | 30 |
| Pivot Turn .....   | 30 |
| Spin Turn .....  | 31 |
| UP AND DOWNHILL TRAVELLING .....                             | 32 |
| PARKING ON A SLOPE .....                                     | 32 |
| PARKING .....  | 32 |
| 1-way or 2-way CIRCUIT SELECTION VALVE OPERATION .....       | 33 |
| IMPORTANT INFORMATION ON EXCAVATOR OPERATION .....           | 34 |
| HOW TO RELEASE PRESSURE TRAPPED IN THE HYDRAULIC SYSTEM..... | 34 |
| TRANSPORTING THE EXCAVATOR ON A TRUCK.....                   | 35 |
| LIFTING OF THE EXCAVATOR.....                                | 37 |
| MAINTENANCE.....   | 39 |
| MAINTENANCE INTERVALS .....                                  | 39 |
| OPENING AND CLOSING OF PARTS.....                            | 41 |
| Opening and Closing of the Fuel Tank Cap.....                | 41 |
| Opening/Closing of the Engine Hood .....                     | 41 |
| Opening/Closing of the Side Cover .....                      | 42 |
| Opening/Closing of the Radiator Cover .....                  | 42 |
| Opening/Closing of the Swivel Frame Cover.....               | 42 |
| Where to store the Grease Gun.....                           | 42 |
| Where to keep Operator's Manual .....                        | 43 |
| Cup Holder.....  | 43 |
| DAILY CHECKS.....  | 43 |
| Checking Coolant Level.....                                  | 43 |
| Checking Fuel Level .....                                    | 44 |
| Checking Engine Oil Level.....                               | 44 |
| Checking Hydraulic Oil Level.....                            | 45 |
| Lubrication Points .....                                     | 46 |
| Check Fan Belt .....   | 47 |
| Checking Radiator and Oil Cooler .....                       | 47 |
| Checking Washer Liquid (only for CAB type) .....             | 48 |
| Checking and Cleaning Engine and Electrical Wiring.....      | 48 |
| Washing Whole Machine .....                                  | 48 |

---

|  |    |
|--|----|
| REGULAR CHECKS AND MAINTENANCE WORK .....  | 49 |
| EVERY 50 SERVICE HOURS .....   | 49 |
| Draining the Water from the Fuel Tank.....   | 49 |
| Draining Water Separator .....   | 49 |
| Battery .....  | 50 |
| Battery Charging.....  | 50 |
| Greasing of Swing Bearing Teeth.....   | 51 |
| EVERY 200 SERVICE HOURS .....  | 51 |
| Checking Fan Belt Tension.....   | 51 |
| Checking Radiator Hoses and Clamps.....  | 52 |
| Inspection and Cleaning Air Filter Element.....  | 52 |
| Air Filter Maintenance.....  | 53 |
| Greasing Swing Bearing.....  | 53 |
| Checking Fuel Line and Intake Air Line .....   | 53 |
| EVERY 250 SERVICE HOURS .....  | 54 |
| Lubrication of the Pilot Valve .....   | 54 |
| EVERY 500 SERVICE HOURS .....  | 54 |
| Changing Engine Oil (Change the engine oil every 500 hours, or every 1 year in the case that service hour is less than 500 hours).....                                     | 54 |
| Replacing Engine Oil Filter Cartridge (Replace the engine oil filter cartridge every 500 hours, or every 1 year in the case that service hour is less than 500 hours)..... | 55 |
| Drive unit Oil Change(First Oil Change of the 50 hours) .....  | 56 |
| Replacing Fuel Filter Cartridge .....  | 56 |
| Replacing Hydraulic Return Filter Element.....   | 57 |
| EVERY 1000 SERVICE HOURS .....   | 57 |
| Replacing the Hydraulic Pilot Filter Element.....  | 57 |
| Hydraulic Oil Change (Including Replacing of the Suction Filter in the Hydraulic Tank) .....   | 58 |
| Hydraulic Oil Check with Hydraulic Breakers .....  | 59 |
| EVERY 1000 SERVICE HOURS OR ONCE A YEAR .....  | 59 |
| Replacing Air Filter Element .....   | 59 |
| EVERY 1500 SERVICE HOURS .....   | 59 |
| Checking Fuel Injection Nozzle (Injection Pressure) .....  | 59 |
| EVERY 2000 SERVICE HOURS .....   | 59 |
| Changing Front Idler and Track Roller Oil .....  | 59 |
| Checking the Alternator and Starter Motor .....  | 59 |
| EVERY 3000 SERVICE HOURS .....   | 60 |
| Checking Injection Pump.....   | 60 |
| ANNUAL SERVICING.....  | 60 |
| Electrical Wiring and Fuses .....  | 60 |
| Checking the Electrical Circuit.....   | 60 |
| BIENNIAL SERVICING .....   | 60 |
| Replacement of Radiator Hoses and Hose Clamps .....  | 60 |
| Changing Radiator Coolant .....  | 60 |
| Replacing Fuel Hoses and Hose Clamps .....   | 61 |
| Replacing Intake Air line.....   | 61 |
| OTHER ADJUSTMENTS AND REPLACEMENTS.....  | 62 |
| PURGING OF THE FUEL SYSTEM .....   | 62 |
| ADJUSTMENT OF TRACKS .....   | 62 |
| Special Information when Using Rubber Tracks.....  | 63 |
| CHANGING THE BUCKET .....  | 64 |
| FUSES .....  | 64 |

|   |    |
|---|----|
| Replacing Fuses .....                           | 64 |
| Fuse Capacities and Circuits .....              | 64 |
| Slow Blow Fuse .....                            | 64 |
| TRUBLESHOOTING.....                             | 65 |
| KUBOTA I.C.S. NAVIGATION LIST OF MESSAGES ..... | 66 |
| OPERATION UNDER COLD WEATHER CONDITIONS .....   | 71 |
| PREPARATION FOR OPERATION IN COLD WEATHER ..... | 71 |
| PROCEDURE AFTER COMPLETING WORK .....           | 71 |
| LONG STORAGE .....                              | 72 |
| RECOMMENDED OILS.....                           | 74 |
| MAIN DIMENSIONS .....                           | 76 |
| LIFTING CAPACITY .....                          | 78 |





# SAFE OPERATION

Careful operation is your best insurance against an accident.

**Read and understand this manual carefully, before operating the excavator.**

Every user, however experienced, should carefully read and understand this manual and those of the attachments and accessories before operating the excavator. The owner is obliged to inform all operators of these instructions in detail.

Keep this manual in the storage location. (See "Where to keep Operator's Manual" in "MAINTENANCE" section.)

## 1. BEFORE OPERATION

1. Know your equipment and its limitations. Read and understand this entire manual before attempting to start and operate the excavator.

2. Pay special attention to and obey the danger, warning and caution labels on the machine.

3. For your safety, a ROPS/OPG (Top Guard Level I) with a seat belt is installed by KUBOTA.

- ROPS: Roll-Over Protective Structure
- OPG (Top Guard Level I): Operator Protective Guards of Top Guard Level I

OPG (Top Guard Level I) in accordance with ISO10262 is equivalent in definition to FOPS (Falling Object Protective Structure).

Always use the seat belt when the machine is equipped with a ROPS/OPG (Top Guard Level I) as this combination will reduce the risk of serious injury or death, should the excavator be upset or falling objects occur.

Do not modify any structural members of the ROPS/OPG (Top Guard Level I) by welding, drilling, bending, grinding or cutting, as this may weaken the structure. If any component is damaged, replace it. Do not attempt repairs. If the ROPS/OPG (Top Guard Level I) is loosened or removed for any reason, make sure all parts are reinstalled correctly. Tighten mounting bolts to proper torque.

4. ROPS meets requirements of ISO 3471.

OPG (Top Guard Level I) meets requirements of OSHA 1926-1003/ISO 10262.

5. The seat belt must be inspected regularly and replaced if frayed or damaged.

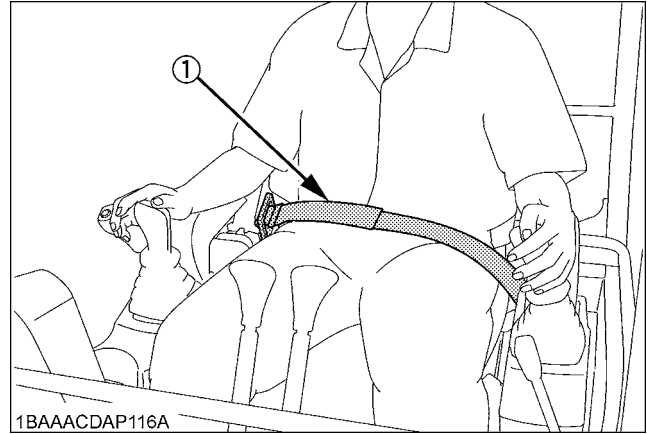

1BAAACDAP116A

(1) Seat belt

6. Always sit in the operator's seat when starting engine or operating levers or controls.

7. Study control lever pattern A and pattern B. Then choose the one which is most familiar.

Familiarize yourself with the pattern selected by operating the unit slowly and at low engine speed.

- The lever and red knob will be locked automatically when the new pattern position is reached.
- Do not operate the excavator unless the lever and red knob have been locked into a pattern position.

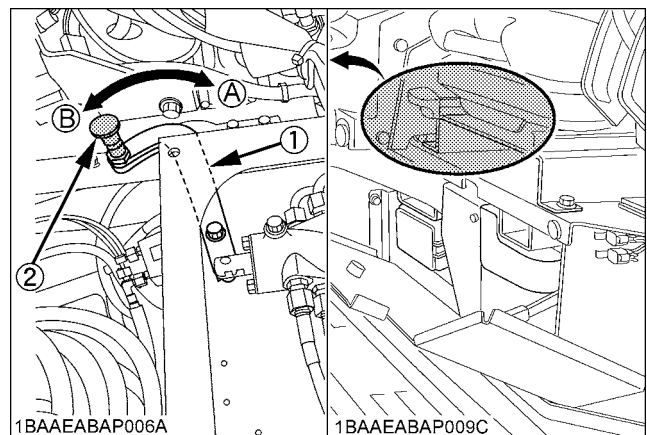

1BAAEABAP006A

1BAAEABAP009C

(1) Pattern selector lever (A) "Pattern A"  
(Two Pattern Selection System: TPSS) (B) "Pattern B"  
(2) Red knob

## ▲-2 SAFE OPERATION

8. Do not operate the excavator while under the influence of alcohol, medication, controlled substances or while fatigued.
9. Check the surroundings carefully before using the excavator or when attachments are being attached.
  - Pay attention to the overhead clearance with electric wires.

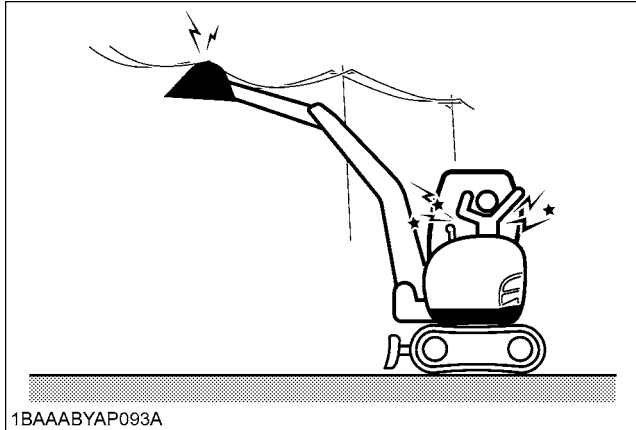

- Check for pipes and buried cables before digging. Use your local utility service to check for such items (if available).
- Check for hidden holes, hindrances, soft underground, and overhangs.

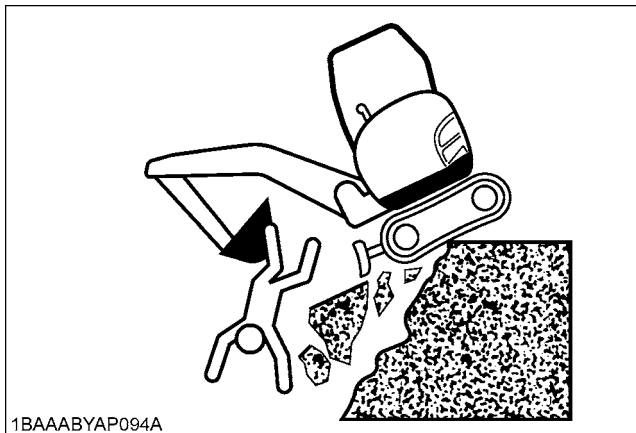

- Do not allow any persons within the working range of the excavator during operation.
10. Do not allow anyone to use the excavator until they have been advised of the work to be performed and they have indicated that they have read and understood the operator's manual.

11. Do not wear baggy, torn or oversized clothing when working with the excavator as such clothing can get caught in rotating parts or control elements which can cause accidents or injuries. Wear adequate safety clothing, e.g. safety helmet, safety shoes, eye protection, ear protection, working gloves, etc., as necessary and as prescribed by law or statutes.

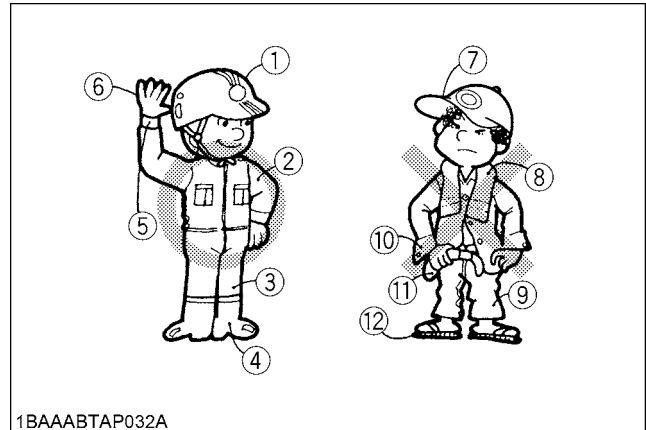

- |                           |                                 |
|---------------------------|---------------------------------|
| (1) Helmet                | (7) Soft hat                    |
| (2) Clothing fit for work | (8) Towel                       |
| (3) Tight seams           | (9) Baggy trousers              |
| (4) Good grip footwear    | (10) Loose cuffs of the shirt   |
| (5) Well fitting cuffs    | (11) Baggy shirt                |
| (6) Working gloves        | (12) Sandals or open-toed shoes |

12. Do not allow passengers to ride on any part of the excavator at any time. The operator must remain in the excavator seat during operation.
13. Check levers, pedals and all mechanical parts for correct adjustment and wear. Replace worn or damaged parts immediately. Check nuts and bolts regularly for correct torque.
14. Keep your excavator clean. Heavy soiling, grease, dust and grass can cause fires, accidents or injuries.
15. Use only KUBOTA authorized attachments.
16. Before starting the excavator, be absolutely sure that the excavator has been filled with fuel, lubricated, greased and undergone all necessary maintenance.
17. Do not modify the excavator, as such could lead to unforeseen safety problems.
18. Do not operate a hydraulic hammer on anything that is above the operator's seat level as objects may fall into the operator station.
19. Make sure attachments, particularly those utilizing quick attach systems, are securely mounted.
20. Install protective guards on the excavator when working in areas where objects may fall or be thrown.

## 2. OPERATING THE EXCAVATOR

Operator safety is a priority. Safe operation, specifically with respect to overturning hazards, entails understanding the equipment and environmental conditions at the time of use. Some prohibited uses which can affect overturning hazards include traveling and turning with implements and loads carried too high etc. This manual sets forth some of the obvious risks, but the list is not, and cannot be, exhaustive. It is the operator's responsibility to be alert for any equipment or environmental condition that could compromise safe operation.

### ◆ Starting

1. Mount and dismount the machine safely. Always face the machine. Always use handrails and available steps and keep yourself well balanced. Do not grab or hold any of the control levers and switches. Do not jump on or off the machine, whether stationary or in motion.
2. Start and control the excavator only from the operator's seat. The driver should not lean out of his seat when the engine is running.
3. Before starting the engine, make sure that the lock levers are in the "LOCKED" position and all control levers and pedals are in their neutral positions and the seat belt is fastened correctly.  
Before starting the engine, make sure that the control levers, travel lever, pedals and other control elements are not stuck and can be moved smoothly.  
If stuck, for example, a lever may fail to return, possibly putting you in danger.  
If anything wrong is found, immediately pinpoint the cause and correct it.
4. Before operating the excavator, make sure that the dozer blade is in front of you. If the levers are activated with the dozer blade at the rear, the tracks will move in the opposite direction of the drive levers.

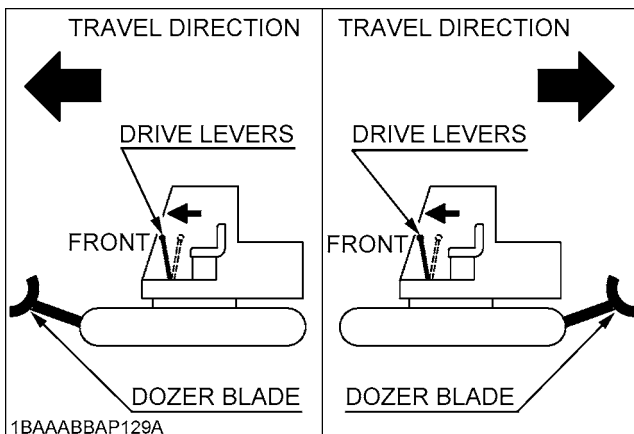

1BAAABBAP129A

### ◆ Working

1. Do not operate or idle engine in a non-ventilated area. Carbon monoxide gas is colorless, odorless, and deadly. If you experience the initial symptoms of low to moderate CO poisoning, which include the following, stop operation, seek medical attention and contact your local dealer. These symptoms are: headache, fatigue, shortness of breath, nausea, or dizziness.

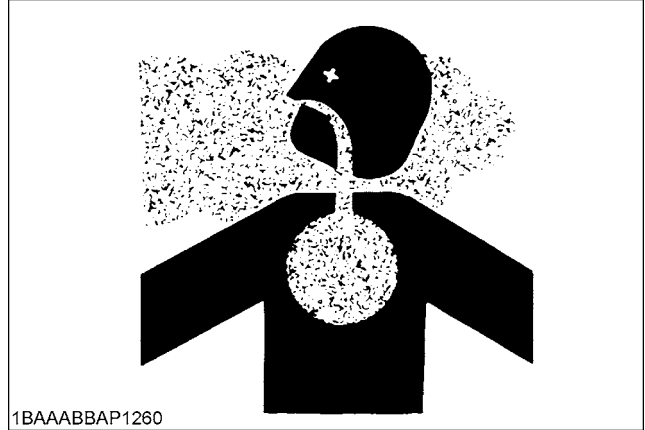

1BAAABBAP1260

2. Keep all safety equipment and covers in place. Replace damaged or missing safety devices.
3. When operating, keep hands and body inside of the ROPS / OPG (Top Guard Level I) protective envelope.
4. Take precautions against tipping over. Stay away from steep slopes and embankments. Do not swing the bucket downhill. Lower the dozer blade when digging. Keep the bucket as low as possible while driving uphill. Turn slowly on slopes (at reduced speed). Do not place the excavator near the edges of trenches and banks, as the earth can give way due to the weight of the excavator.  
Never cross an incline horizontally or at an angle, which can cause the machine to rollover. Approach inclines vertically to avoid loss of control. Avoid performing any work with the machine when it is on an incline, which could cause it to become unbalanced and rollover. Always take care when moving the machine on an incline.
5. Watch where you are going at all times. Watch for and avoid obstacles. Remain alert for trees, wires and other obstructions.
6. Do not change direction on steep slopes, or the excavator could tip over. Before changing direction, beware of people in the work area.
7. When the working light alone do not provide sufficient visibility, prepare additional stationary artificial lighting and observe safety rules for night work.
8. When towing the excavator or pulling a load, the load must be less than the strength of the towing line attached to excavator.

## ▲-4 SAFE OPERATION

|                                     |                                |
|-------------------------------------|--------------------------------|
| Max. drawbar pull at coupling hook  | 70.4 kN (7184 kgf) [15838 lbf] |
| Max. vertical load at coupling hook | 7.2 kN (735 kgf) [1621 lbf]    |

9. The towing eye should not be used for tie down or lifting of the machine.
10. When the excavator is parked or left unattended on a slope, be sure to put the bucket on the ground and place all control levers in neutral position, then brace the tracks with chocks.
  - When working in groups, always let the others know what you are going to do before you do it. Keep others away from the machine working area. Be sure to lock the boom swing pedal when the boom swing function is not used.
11. For details of operating the excavator, see the "EXCAVATOR OPERATION" section.

### ◆ Safety for children

Tragedy can occur if the operator is not alert to the presence of children. Children generally are attracted to machines and the work they do.

1. Never assume that children will remain where you last saw them.
2. Keep children out of the work area and under the watchful eye of another responsible adult.
3. Be alert and shut your machine down if children enter the work area.
4. Never carry children on your machine. There is not a safe place for them to ride. They may fall off and be run over or interfere with your control of the machine.
5. Never allow children to operate the machine even under adult supervision.
6. Never allow children to play on the machine or on the attachments.
7. Use extra caution when backing up. Look behind and down to make sure the area clear before moving.

## 3. AFTER OPERATION

Before leaving the machine,

- Park the excavator on a firm, flat and level surface. If this is not possible, park across the slope.
- Lower the attachments and the dozer blade to the ground.
- Stop the engine.
- Release pressure in the hydraulic system.
- Lock all control levers.
- Remove the key.
- Lock the CAB door (if equipped).

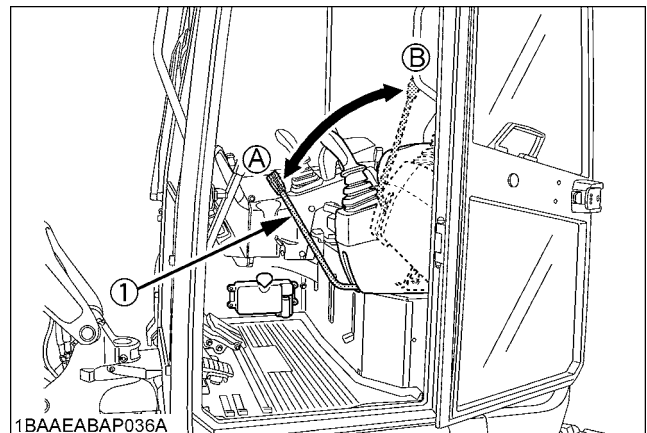
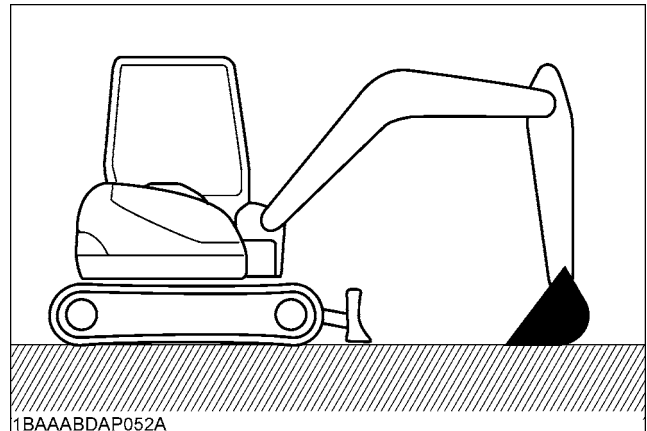

(1) Pilot control lock lever

(A) "UNLOCK"

(B) "LOCKED"

#### 4. SAFE LOADING AND TRANSPORT OF THE EXCAVATOR

1. Observe all regulations concerning the transport of excavators on public roads.
2. Use adequately long and robust ramps when loading on the machine. (for details see "TRANSPORTING THE EXCAVATOR ON A VEHICLE")
3. Do not change the running direction and to avoid tipping over, do not try to swing the attachment crosswise to the loading ramps.
4. Lower the attachment on the loading bed and release the pressure from the hydraulic system. Stop the engine then remove the key. After loading the excavator on the truck, block the tracks with blocks and tie down the excavator at the appropriate locations.

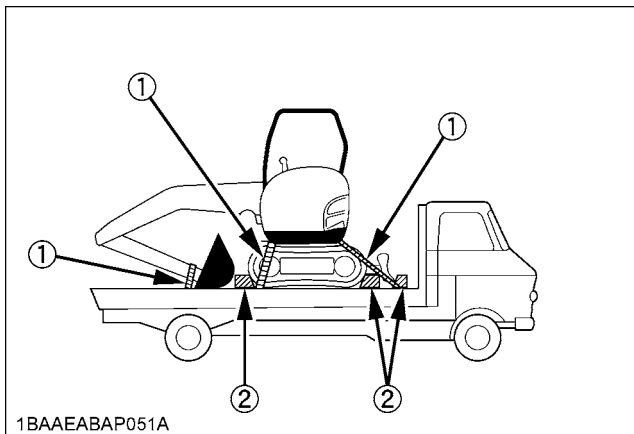

- (1) Chain  
(2) Block

5. Avoid abrupt braking of the vehicle with the excavator loaded. Sudden braking cause the excavator to move and may cause a serious accident.
6. Do not use the hooks on the roof of cab or canopy for lifting the excavator.

#### 5. MAINTENANCE

Before doing maintenance work on the excavator, place the machine on a firm, flat and level surface, lower the attachments to the ground, stop the engine, release pressure trapped in the hydraulic system, lock all control levers and remove the key. When dismantling hydraulic parts, make sure that the hydraulic oil has cooled down sufficiently to avoid burns.

Start maintenance work carefully, e.g. loosen plug slowly so that oil will not squirt out.

1. Before doing work on the engine, the exhaust system, the radiator and the hydraulics, let the excavator cool down sufficiently.
2. Always turn off the engine when filling the fuel tank. Avoid spilling and over-filling of fuel.
3. Smoking is prohibited while refueling or handling the battery. Keep sparks and fire away from the fuel tank and battery. Flammable gases escape from the battery, especially during charging.
4. Do not use or charge a refillable type battery if the fluid level is below the LOWER (lower limit level) mark. Otherwise, the battery component parts may prematurely deteriorate, which may shorten the battery's service life or cause an explosion. Check the fluid level regularly and add distilled water as required so that the fluid level is between the UPPER and LOWER levels.
5. Read and follow the directions "STARTING WITH AN AUXILIARY BATTERY" in "OPERATION OF THE ENGINE", when starting with an auxiliary battery.
6. Keep a first-aid box and a fire extinguisher at hand at all times.

## ▲-6 SAFE OPERATION

7. Do not open the radiator cap before the radiator has cooled down sufficiently.  
First loosen the cap to the first stop and allow the system enough time to release the remaining pressure. Then loosen the cap completely.

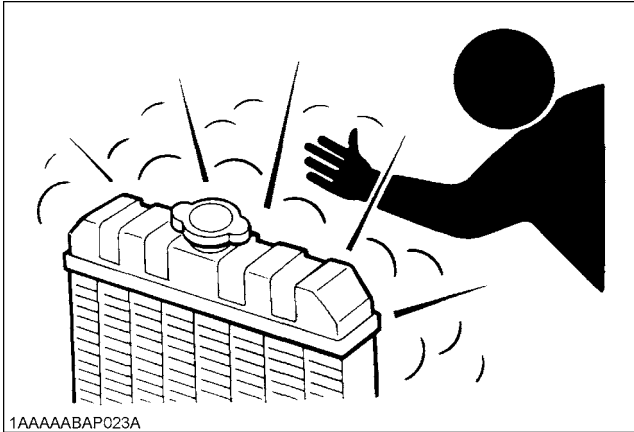

8. To avoid short-circuiting the battery, always remove the ground cable first and attach the positive cable first.
9. Oil under high pressure can penetrate the skin and may be harmful to your health if not treated immediately.
10. Leaking hydraulic fluid has enough pressure to penetrate the skin and cause serious injuries. Leakages from pin holes can be totally invisible. Do not use hands for checking for leaks. Always use a piece of wood or cardboard. It is strongly recommended that you use a face mask or eye protection.  
Should injuries occur with leaking hydraulic fluid, contact a doctor immediately. This fluid can cause gangrene or serious allergic reactions.

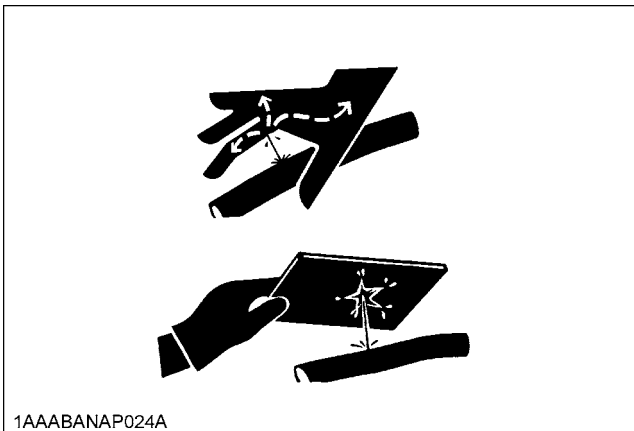

11. To avoid environmental damage from acid and heavy metals, dispose of the battery appropriately.
12. Observe all laws and regulations concerning the disposal of used oil, coolants, solvents, hydraulic fluids, battery acids and batteries.

13. To avoid fire, do not heat the hydraulic components (tanks, pipes, hoses, cylinders) before they have been drained and washed.

14. Use eye protection or a face mask to protect the eyes and respiratory system against dust and other foreign particles.

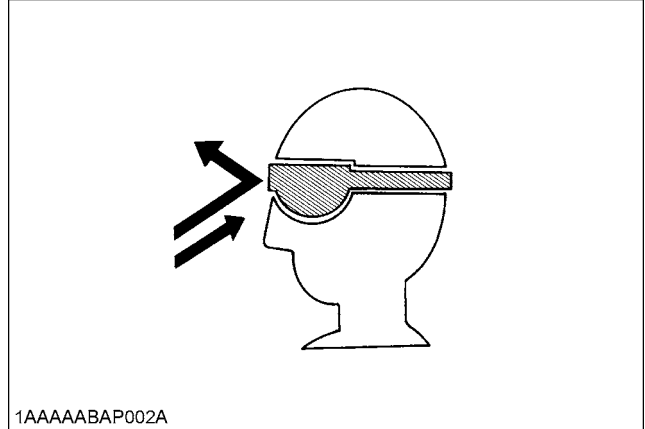

15. Securely support excavator with stands or suitable blocking before working underneath. For your safety, do not work under any hydraulically supported devices. They can settle, suddenly leak down, or be accidentally lowered.

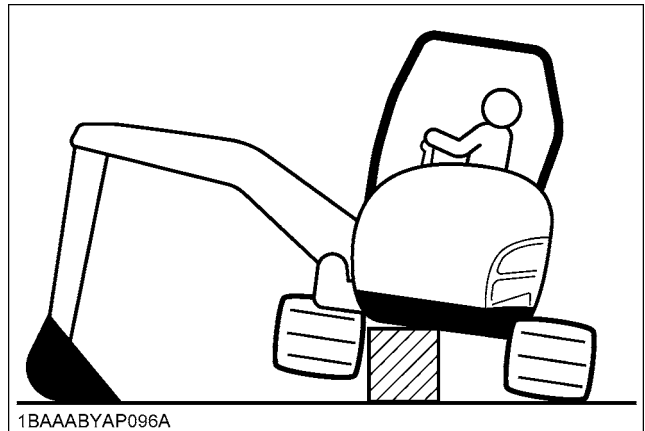

16. Do not dismantle the spring of the track tensioner. If dismantling is necessary, contact your KUBOTA dealer where the machine was purchased, or competent service shop. The assembly must be done according to the KUBOTA work shop manual (W.S.M.) for the product involved.

17. When lifting the machine itself with an attachment, place a safety block or safety post to prevent the machine from rolling over. Keep the pilot control lock lever in the "LOCKED" position.

18. Inspect ROPS / OPG (Top Guard Level I) for damage and if damage is found contact your KUBOTA dealer for repair.

19. KUBOTA does not use asbestos containing components and recommends against the use of such components. Components containing asbestos should be handled in accordance with applicable regulations and industry practice.
20. Do not open a high-pressure fuel system. High-pressure fluid remaining in fuel lines can cause serious injury. Do not disconnect nor attempt to repair fuel lines, sensors, or any other components between the high-pressure fuel pump and injectors on engines with high-pressure common rail fuel system.
21. To avoid hazardous high voltage, turn the key switch to the "STOP" position and disconnect the battery ground cable if it is necessary to check to repair the computer, harness or connectors.
22. Fire prevention

Excavator and some attachments have components that are at high temperatures under normal operating conditions. The primary source of high temperatures is the engine and exhaust system. The electrical system, if damaged or incorrectly maintained, can be a source of arcing or sparks.

The following fire prevention guidelines will help to keep your equipment up and running efficiently and keep the risk of fire to a minimum.

- Blow off all accumulated debris near hot engine exhaust components such as turbocharger and exhaust manifold as well as exhaust pipes and muffler more frequently when working in severe conditions.
- Clean out all accumulated flammable debris such as leaves, straw, pine needles, branches, bark, small wood chips and any other combustible materials from inside the machine belly pans or lower unit structures as well as from area in proximity to the engine.
- Inspect all fuel lines and hydraulic hoses for wear or for deterioration. Replace them immediately if they begin to leak.
- Examine electrical wiring and connectors frequently for damage. Repair any wires that are loose or frayed before operating the machine. Clean all electrical connections and tighten all electrical connections as necessary.
- Inspect the exhaust system daily for any signs of leakage. Check for broken pipes and muffler and also for loose or missing bolts, nuts and clamps. If any exhaust leaks or fractured parts are found, repairs must be completed prior to operation.
- Always keep a multipurpose fire extinguisher on or near the machine. Be familiar with the operation of the fire extinguisher.

### 6. DANGER, WARNING AND CAUTION LABELS

Keep the safety and warning symbols (labels ) on the excavator clean and legible, replacing them if necessary. The positioning of the safety symbols is illustrated in the following figures.

- (1) Part No. R2491-5796-1  
(Both sides)  
Lifting point

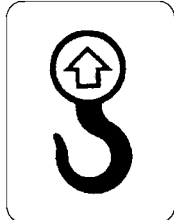

1BAAAAQAP0940

- (2) Part No. RG158-5737-2  
Diesel fuel only No fire



1BBABBKAP201A

- (3) Part No. RG268-5789-2  
(Both sides)  
Do not enter the working range.



1BAAEABAP013A

- (4) Part No. RG109-5796-1  
(Both sides)  
Forbidden lift point

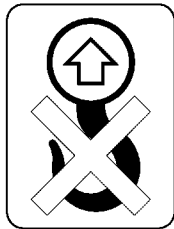

1BAABAUAP2720

- (5) Part No. RG138-5791-1  
(Both sides)  
Do not loosen the grease fitting completely or too quickly.

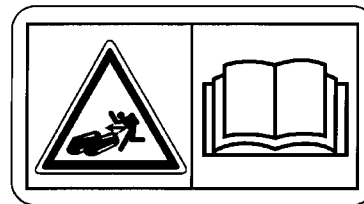

1BAABAMAP0010

- (6) Part No. RG158-5822-2  
(Both sides)



1BAAGAAP0270

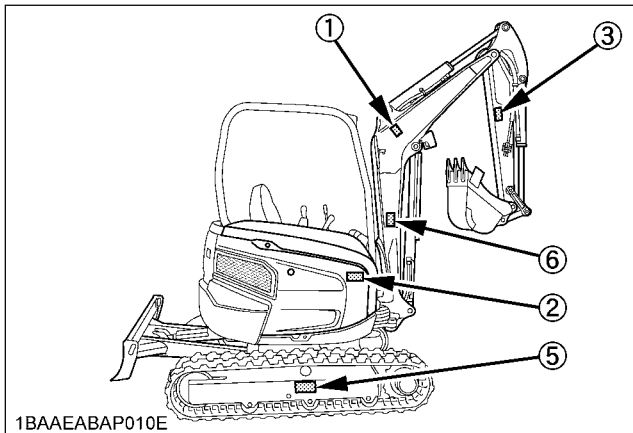

1BAAEABAP010E

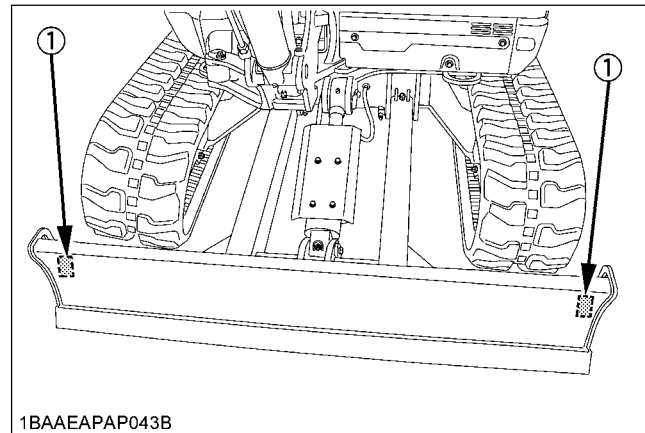

1BAAEAPAP043B

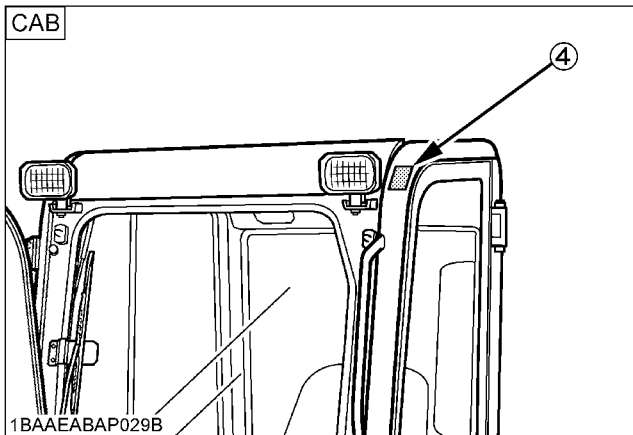

1BAAEABAP029B

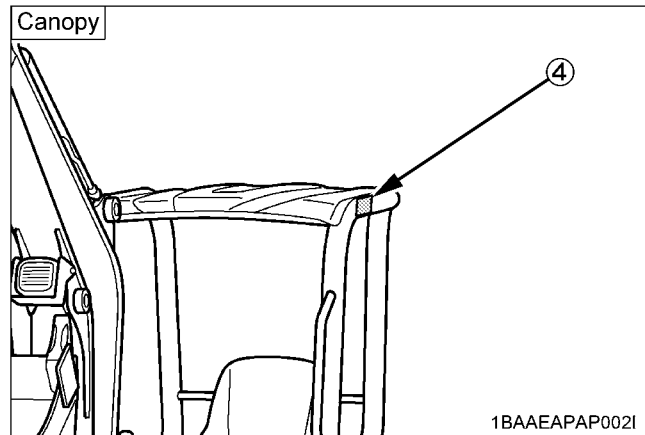

1BAAEAPAP002I



- (1) Part No. RG158-5721-1  
Do not touch hot parts, such as exhaust muffler, etc.

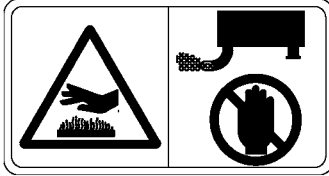

1BAAACDAP2060

- (2) Part No. RG158-5727-1  
Do not allow any persons within the working range.

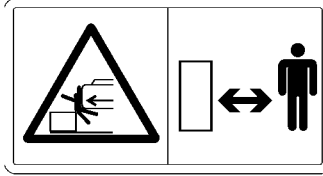

1BAAACDAP2080

- (3) Part No. RG248-5724-1  
Do not touch hot parts.



1BAAEABAP013A

- (4) Part No. RH418-5714-1



1BAAEABAP014A

- (6) Part No. RH418-5761-1



1BAAEABAP020A

- (5) Part No. RH418-5763-1



1BAAEABAP019A

- (7) Part No. RG158-5726-1  
Keep away from fan and fan belt.

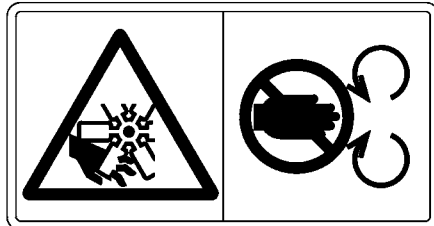

1BAAACDAP2050

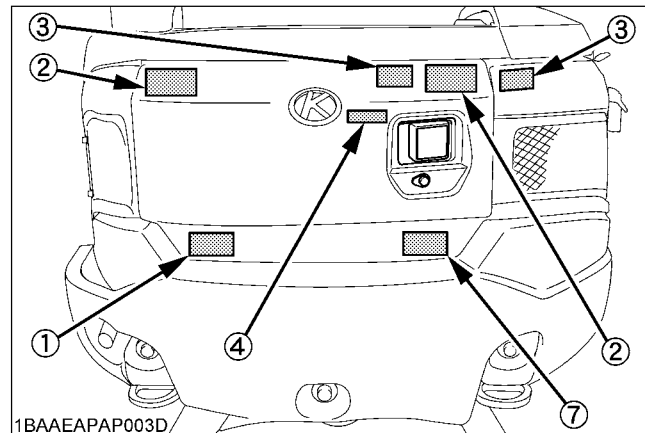

1BAAEAPAP003D

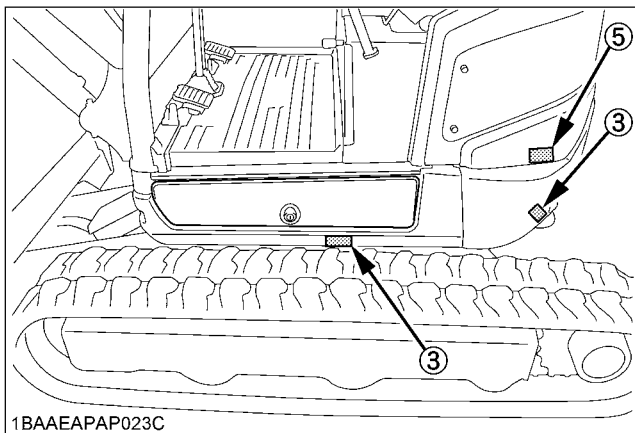

1BAAEAPAP023C

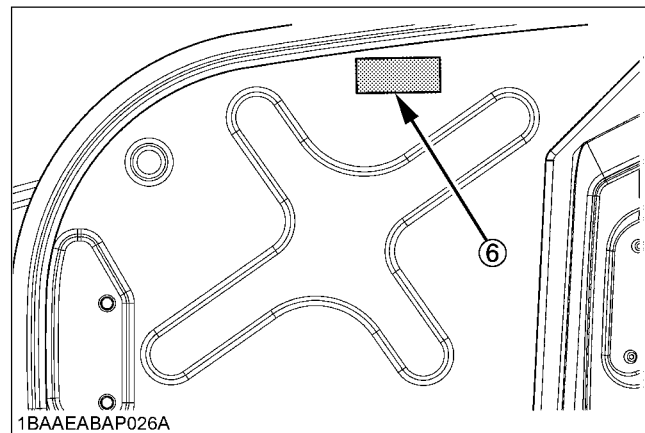

1BAAEABAP026A

▲-10 SAFE OPERATION

- (1) Part No. RG158-5789-1  
Keep away from fan and fan belt.



1BAAACDAP2030

- (2) Part No. RG158-5785-2  
Do not touch hot parts such as exhaust, etc.



1BAAACDAP2040

- (3) Part No. RH418-5764-1



1BAAEABAP017A

- (4) Part No. RG248-5724-1  
Do not touch hot parts.



1BAAEABAP013A

- (5) Part No. RH418-5824-1



1BAAEABAP016A

- (6) Part No. RG158-5765-2

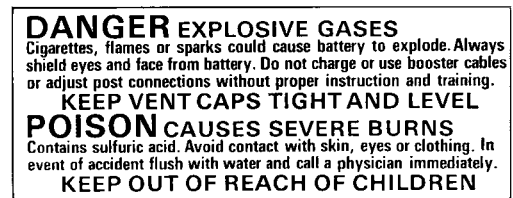

1BAAGAAP0360

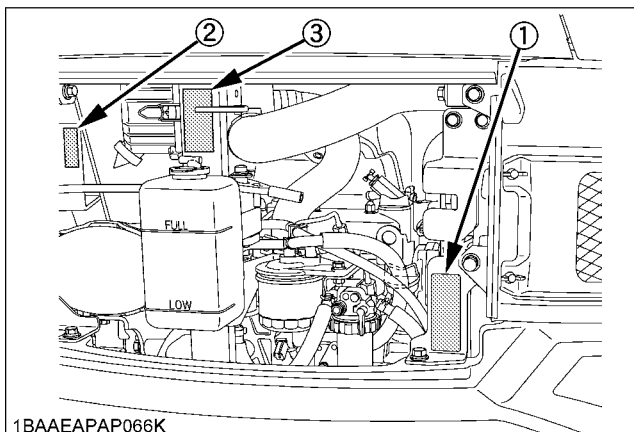

1BAAEAPAP066K

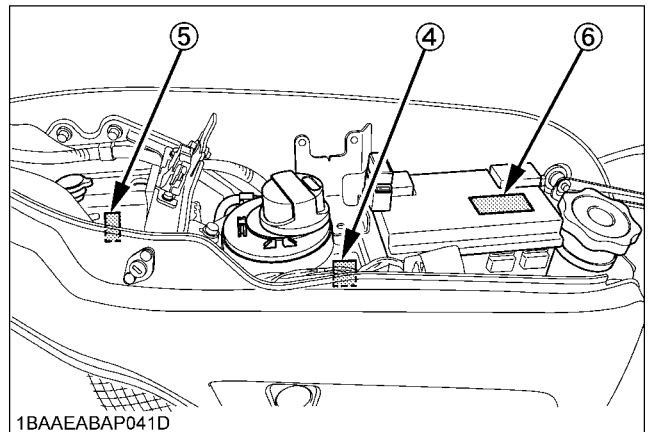

1BAAEABAP041D

- (1) Part No. RG308-5702-1  
Read and understand Operator's Manual before operating this machine.

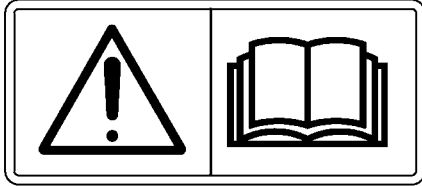

1BAAEABAP018A

- (2) Part No. RG158-5736-2



1BAAACDAP243A

- (3) Part No. RG158-5739-2

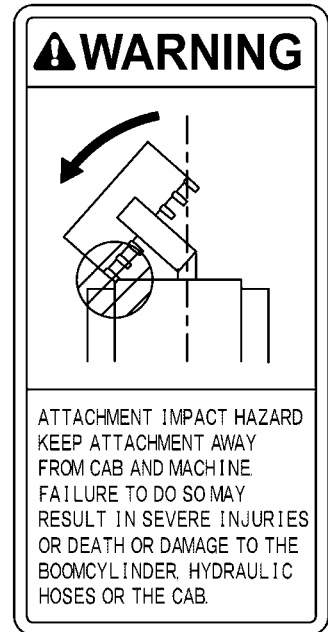

1BAAACDAP244A

- (4) Part No. RG158-5741-2



1BAAACDAP2450

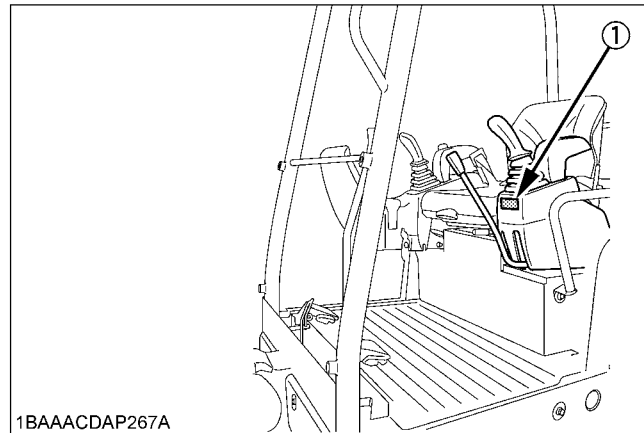

1BAAACDAP267A

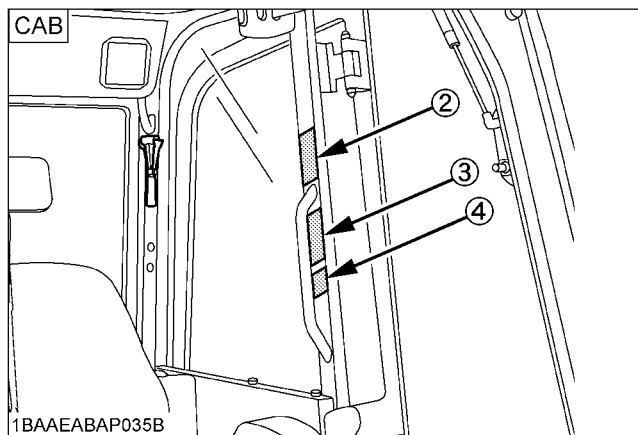

1BAAEABAP035B

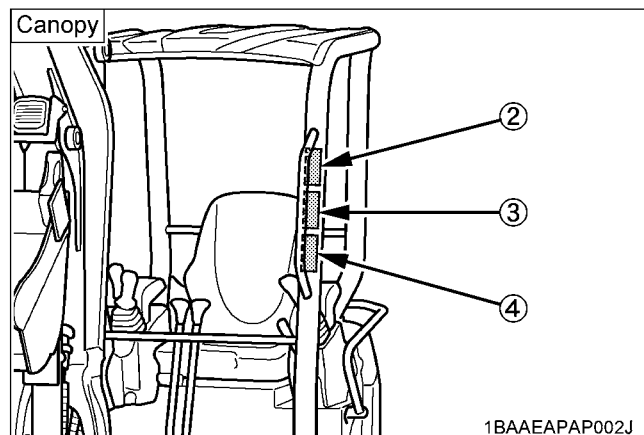

1BAAEAPAP002J

(1) Part No. RH418-5728-1

**⚠ WARNING**

**TO AVOID PERSONAL INJURY:**

1. Read and understand operators manual before attempting to start or operate the excavator.
2. Before starting engine, make sure all control levers are in neutral and the operating area is clear of all bystanders.
3. Never allow passengers on any part of the excavator while operating.
4. Know your work area before starting operation.
  - Check underground lines and cables.
  - Stay off slopes too steep for safe operation.
  - Check overhead clearance with electric wires.
  - Check for hidden holes, obstacles or drop-offs and overhangs.
5. Make sure all shields are in place and securely fastened.
6. Before dismounting from the machine, lower all attachment to the ground, stop the engine and remove the key.
7. Damaged ROPS must be replaced, not repaired or revised.

**IMPORTANT** Never use boom, dipper, or bucket to hammer or beat sideways. Excavator is not intended for these usages.

1BAAEABAP021A

(2) Part No. RH418-5733-3

Pattern B ← Pattern A

FRONT
REAR

**⚠ WARNING**

**TO AVOID PERSONAL INJURY:**

1. Study control lever pattern A and pattern B. Then choose the which is most familiar.
2. Position the pattern selector lever in either the backward position (pattern A) or the forward position (pattern B).
3. Engage lever lock to prevent accidental pattern change.
4. Familiarize yourself with the pattern selected by operating slowly.

1BAAEABAP022A

(3) Part No. RG158-5725-2

⚠ WARNING

**TO AVOID PERSONAL INJURY OR DEATH:**  
Before moving the excavator, KNOW THE LOCATION OF THE DOZER BLADE. The excavator will travel in the direction of the dozer blade when drive levers are moved away from the operator.

**DO NOT OPERATE WITHOUT ROPS. YOU COULD BE CRUSHED.**

**USE SEAT BELT**

1BAAACDAP252A

(4) Part No. RH418-5753-1

⚠ WARNING

**TO AVOID PERSONAL INJURY:**  
Lock control lever before leaving compartment.

1BAAEABAP024A

(5) Part No. RG158-5729-1

Lock front window securely.



1BAAAAQAP1980

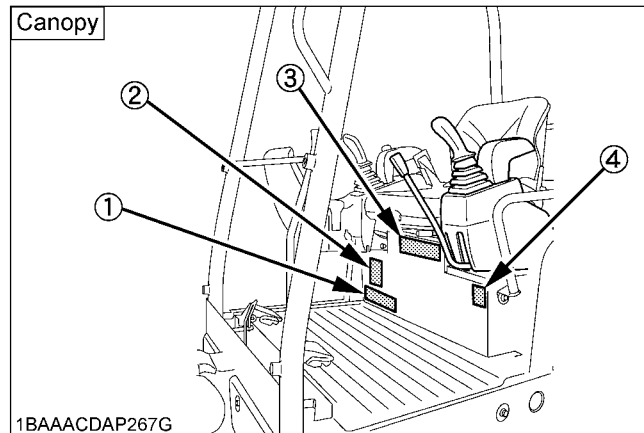

1BAAACDAP267G

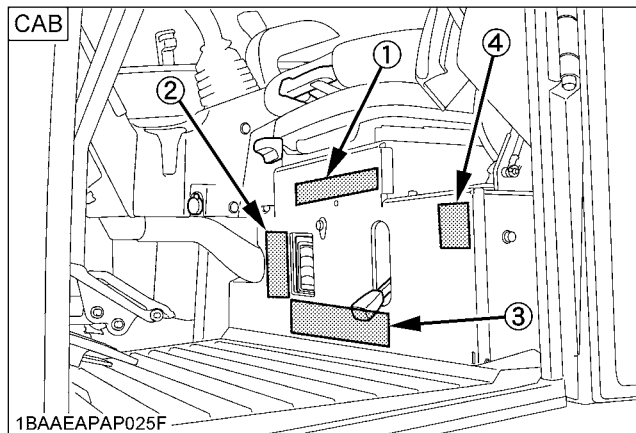

1BAAEAPAP025F

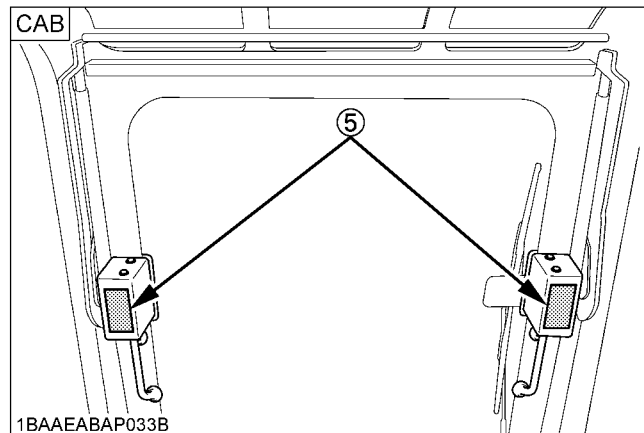

1BAAEABAP033B

(1) Part No. RH418-5793-1

**WARNING**

**TO AVOID PERSONAL INJURY OR DEATH:**

- Do not move raised load over people.
- It is forbidden to lift loads greater than those values mentioned in the lifting capacity tables.
- The values mentioned in the table are valid only on even, hard grounds. When lifting on soft ground, the machine can tilt over due to the fact that the load is concentrated only on one side of the machine.
- The table values are calculated at the end of the arm without the bucket. In order to find the allowable loads for machines with bucket, the bucket weight must be subtracted from the values in the table.

- The lifting capacities are based on ISO 10567 and do not exceed 75% of the static tilt load of the machine or 87% of the hydraulic lifting capacity of the machine.
- The strokes are as follows:
  - The load point corresponds to the front bolt part of the arm.
  - The machine positions are (i) over-front (Blade down), (ii) over-front (Blade up), and (iii) over-side.
  - The operating cylinder is the boom cylinder.
- The bucket of the excavator, the hook, the sliding and other lifting accessories are taken into consideration for the loads.

*"Don't use this machine for the lifting of freely suspended loads. (Unless fitted with appropriate safety devices, as required under local regulations.)"*

| LIFT POINT HEIGHT (ft) | LIFTING CAPACITY OVER-FRONT BLADE DOWN Unit = 1000 lbs. |      |      |      | LIFTING CAPACITY OVER-FRONT BLADE UP Unit = 1000 lbs. |      |      |      | LIFTING CAPACITY OVER-SIDE Unit = 1000 lbs. |      |      |      |      |      |      |      |      |
|------------------------|---|------|------|------|---|------|------|------|---|------|------|------|------|------|------|------|------|
|                        | 4   | 6    | 8    | 10   | 4   | 6    | 8    | 10   | 4   | 6    | 8    | 10   |      |      |      |      |      |
| 10                     |   |      |      | 0.87 |   |      |      | 0.87 |   |      |      | 0.87 |      |      |      |      |      |
| 8                      |   |      |      | 0.87 |   |      |      | 0.87 |   |      |      | 0.87 |      |      |      |      |      |
| 6                      |   |      |      | 1.09 |   |      |      | 0.99 |   |      |      | 1.09 |      |      |      |      |      |
| 4                      |   |      |      | 1.49 |   |      |      | 1.41 |   |      |      | 1.35 |      |      |      |      |      |
| 2                      |   |      |      | 1.84 |   |      |      | 1.35 |   |      |      | 1.10 |      |      |      |      |      |
| 0                      |   |      |      | 2.16 |   |      |      | 2.12 |   |      |      | 1.87 |      |      |      |      |      |
| 2                      | 10  | 3.00 | 1.97 | 1.43 | 1.06  | 2    | 10   | 2.13 | 1.31  | 0.95 | 0.74 | 2    | 10   | 1.67 | 1.07 | 0.73 | 0.81 |
| 4                      | 3.34  | 2.57 | 1.74 | 1.24 |   | 3.34 | 2.15 | 1.33 | 0.95  |      | 3.34 | 1.69 | 1.08 | 0.79 |      |      |      |
| 6                      | 3.05  | 1.77 | 1.17 |      |   | 3.05 | 1.77 | 1.17 |   |      | 3.05 | 1.72 | 1.11 |      |      |      |      |

Machine with ROPS cabin and rubber crawler, without bucket

1BAAEABAP044A

(3) Part No. RH418-5851-1

**WARNING**

**TO AVOID PERSONAL INJURY OR DEATH:**

- Do not move raised load over people.
- It is forbidden to lift loads greater than those values mentioned in the lifting capacity tables.
- The values mentioned in the table are valid only on even, hard grounds. When lifting on soft ground, the machine can tilt over due to the fact that the load is concentrated only on one side of the machine.
- The table values are calculated at the end of the arm without the bucket. In order to find the allowable loads for machines with bucket, the bucket weight must be subtracted from the values in the table.

- The lifting capacities are based on ISO 10567 and do not exceed 75% of the static tilt load of the machine or 87% of the hydraulic lifting capacity of the machine.
- The strokes are as follows:
  - The load point corresponds to the front bolt part of the arm.
  - The machine positions are (i) over-front (Blade down), (ii) over-front (Blade up), and (iii) over-side.
  - The operating cylinder is the boom cylinder.
- The bucket of the excavator, the hook, the sliding and other lifting accessories are taken into consideration for the loads.

*"Don't use this machine for the lifting of freely suspended loads. (Unless fitted with appropriate safety devices, as required under local regulations.)"*

| LIFT POINT HEIGHT (ft) | LIFTING CAPACITY OVER-FRONT BLADE DOWN Unit = 1000 lbs. |      |      |      | LIFTING CAPACITY OVER-FRONT BLADE UP Unit = 1000 lbs. |      |      |      | LIFTING CAPACITY OVER-SIDE Unit = 1000 lbs. |      |      |      |      |      |      |      |
|------------------------|---|------|------|------|---|------|------|------|---|------|------|------|------|------|------|------|
|                        | 4   | 6    | 8    | 10   | 4   | 6    | 8    | 10   | 4   | 6    | 8    | 10   |      |      |      |      |
| 10                     |   |      |      | 0.87 |   |      |      | 0.87 |   |      |      | 0.84 |      |      |      |      |
| 8                      |   |      |      | 0.87 |   |      |      | 0.87 |   |      |      | 0.83 |      |      |      |      |
| 6                      |   |      |      | 1.09 |   |      |      | 0.99 |   |      |      | 1.09 |      |      |      |      |
| 4                      |   |      |      | 1.49 |   |      |      | 1.34 |   |      |      | 1.10 |      |      |      |      |
| 2                      |   |      |      | 1.84 |   |      |      | 1.26 |   |      |      | 1.02 |      |      |      |      |
| 0                      |   |      |      | 2.16 |   |      |      | 2.01 |   |      |      | 1.58 |      |      |      |      |
| 2                      | 10  | 3.00 | 1.97 | 1.43 | 1.06  | 2    | 10   | 2.02 | 1.25  | 0.90 | 0.70 | 2    | 10   | 1.58 | 1.01 | 0.74 |
| 4                      | 3.34  | 2.57 | 1.74 | 1.24 |   | 3.34 | 2.03 | 1.25 | 0.90  |      | 3.34 | 1.60 | 1.02 | 0.74 |      |      |
| 6                      | 3.05  | 1.77 | 1.17 |      |   | 3.05 | 1.77 | 1.17 |   |      | 3.05 | 1.64 | 1.05 |      |      |      |

Machine with ROPS canopy and rubber crawler, without bucket

1BAAEABAP046A

(2) Part No. RH418-5862-1

**WARNING**

**TO AVOID PERSONAL INJURY OR DEATH:**

Mount and dismount safely when entering or leaving the operator's compartment.

- Maintain a three point contact with the steps and handrails
- Face the machine.
- Never jump on or off the machine.
- Never attempt to mount or dismount a moving machine.
- Never use control levers as handles.

1BAAEABAP045A

(4) Part No. RH418-5762-1

**WARNING**

**TO AVOID PERSONAL INJURY OR DEATH:**

Mount and dismount safely when entering or leaving the operator's compartment.

- Maintain a three point contact with the steps and handrails
- Face the machine.
- Never jump on or off the machine.
- Never attempt to mount or dismount a moving machine.
- Never use control levers as handles.

1BAAEABAP047A

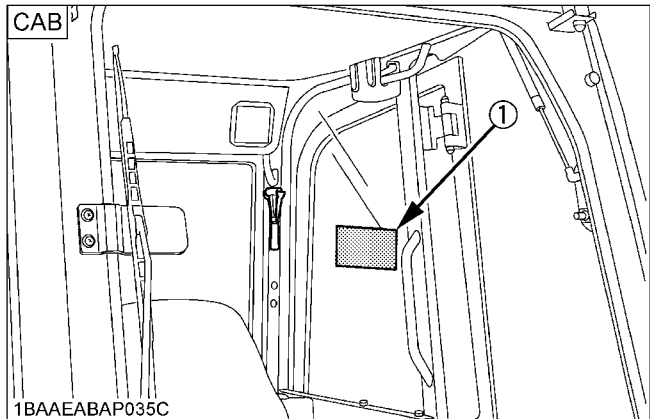

1BAAEABAP035C

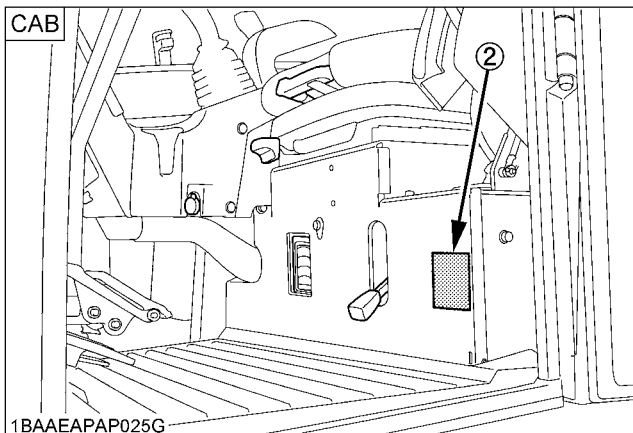

1BAAEAPAP025G

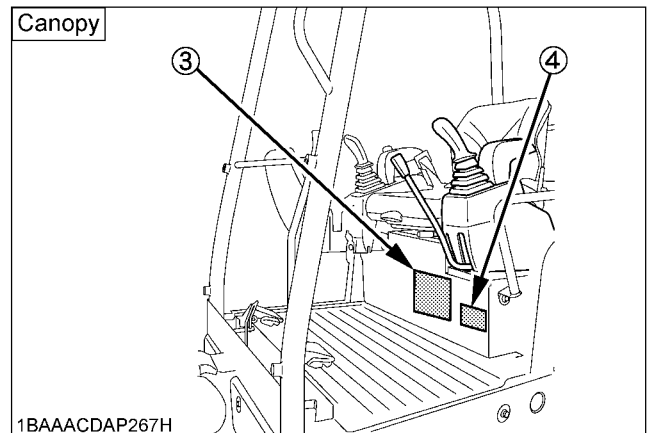

1BAEAACDAP267H

(1) Part No. RG109-5796-1

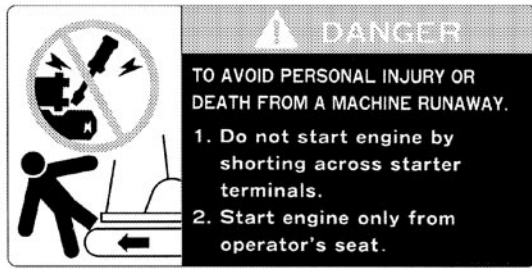

1BAAGAAP0250

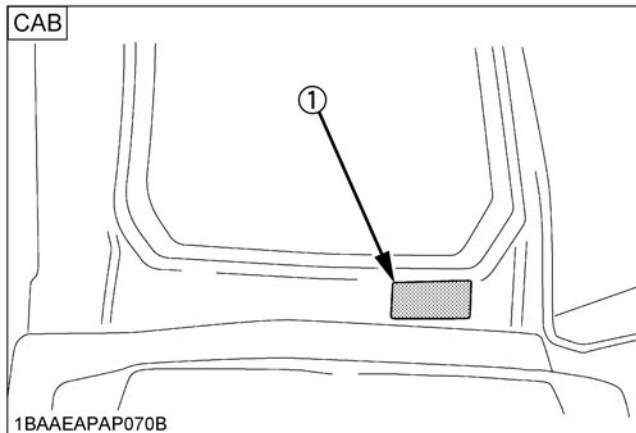

1BAAEAPAP070B

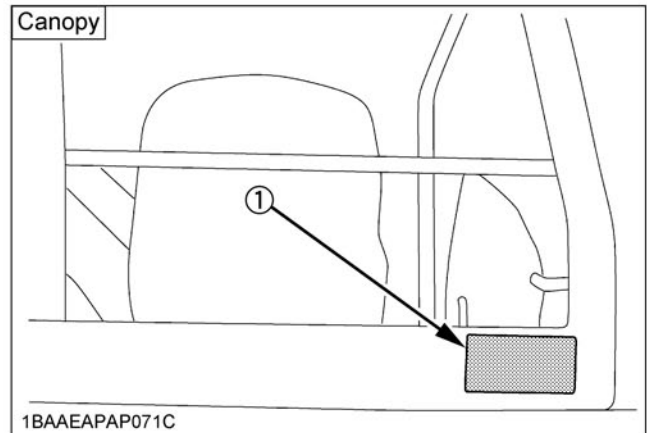

1BAAEAPAP071C

## 7. CARE OF DANGER, WARNING AND CAUTION LABELS

1. Keep danger, warning and caution labels clean and free from obstructing material.
2. Clean danger, warning and caution labels with soap and water, and dry with a soft cloth.
3. Replace damaged or missing danger, warning and caution labels with new labels from your KUBOTA dealer.
4. If a component with danger, warning and caution label(s) affixed is replaced with new part, make sure new label(s) is (are) attached in the same location(s) as the replaced component.
5. Mount new danger, warning and caution labels by applying on a clean dry surface and pressing any bubbles to outside edge.

# DEALER SERVICE

Your KUBOTA dealer is always ready to help so that your excavator offers the best performance. After having carefully read these instructions, you will realize that much of the routine maintenance can be done by yourself. For service, contact the KUBOTA Dealer shop from which you purchased your product, or your local KUBOTA dealer. When ordering spare parts from your KUBOTA dealer, always mention the serial number of the excavator and the engine.

Note these numbers right away in the supplied lines.

|  | Model | Serial No. |
|--|-------|------------|
| Excavator  |       |            |
| Engine   |       |            |
| Dealer's name<br>(To be filled in through the owner) |       |            |
| Date of purchase                                     |       |            |

## ◆ Warranty policy

This product is warranted under the KUBOTA Limited Express Warranty, a copy of which may be obtained from your selling dealer. No warranty shall, however, apply if the product has not been handled according to the instruction given in the Operator's Manual even it is within the warranty period.

The Product(s) described in this Operator's Manual are designed and manufactured only for the country in which they are initially wholesaled by KUBOTA or one of its affiliated companies. Neither KUBOTA Corporation nor its affiliated companies provide warranty for any Product which is re-sold or retailed in any country other than the country for which the Product(s) were designed or manufactured.

## ◆ Scrapping the product and its procedure

To put the product out of service, correctly follow the local rules and regulations of the country or territory where you reside. If you have questions, consult your local KUBOTA Dealer.

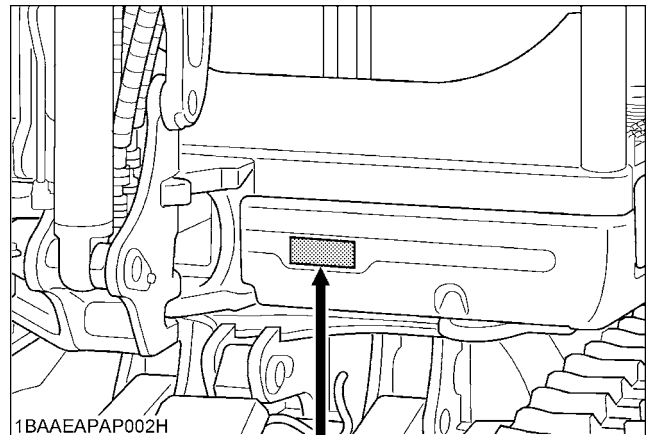

[KTC model]

|  |              |
|--|--------------|
| KUBOTA Baummaschinen GmbH<br>STEINHAUSER STR. 100<br>66482 ZWEIBRÜCKEN GERMANY |              |
| MODEL  | U27-4        |
| SERIAL No.   |              |
| ENGINE No.   |              |
| PRODUCT IDENTIFICATION NUMBER  | WKFRGH1200Z0 |

[KCL model]

|  |              |
|--|--------------|
| KUBOTA Baummaschinen GmbH<br>STEINHAUSER STR. 100<br>66482 ZWEIBRÜCKEN GERMANY |              |
| MODEL  | U27-4        |
| SERIAL No.   |              |
| ENGINE No.   |              |
| PRODUCT IDENTIFICATION NUMBER  | WKFRGH1400Z0 |

1BAAEABAP001B

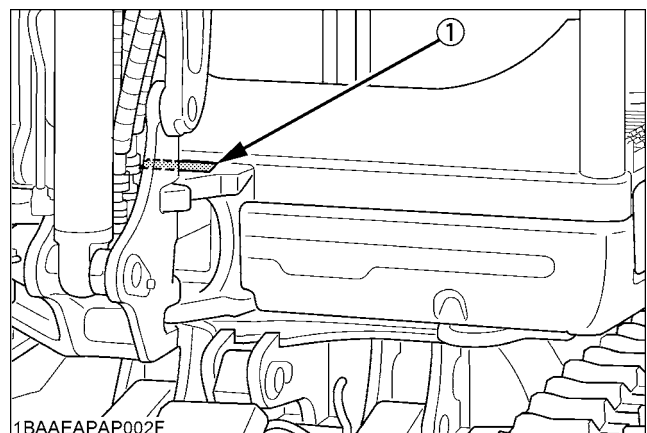

(1) Serial No.

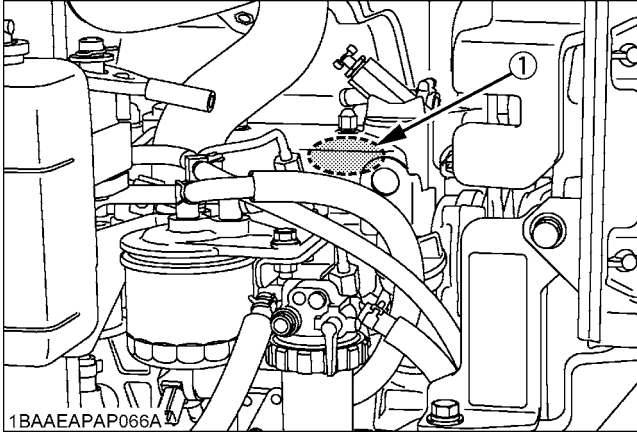

(1) Engine serial No.



# TECHNICAL DATA

|                                     |   | KUBOTA EXCAVATOR                        |                    |                    |  |
|-------------------------------------|---|---|--------------------|--------------------|--|
| Model name                          |   | U27-4                                   |                    |                    |  |
| Type                                |   | canopy                                  | cabin              |                    |  |
| Mass (without operator) kg (lbs.)   |   | 2490 (5490)                             | 2590 (5711)        |                    |  |
| Standard bucket                     | Volume (CECE) m <sup>3</sup> (cu.in.)       | 0.054 (3295)                            |                    |                    |  |
|                                     | Width [with side cutter] mm (in.)           | 450 [475] (17.7 [18.7])                 |                    |                    |  |
|                                     | Weight kg (lbs.)                            | 55 (121)                                |                    |                    |  |
| Engine                              | Type (water cooled 4 cycle Diesel)          | 3 cylinder - diesel engine water cooled |                    |                    |  |
|                                     | Model name                                  | KUBOTA D1105-E4-BH-5                    |                    |                    |  |
|                                     | Total displacement cm <sup>3</sup> (cu.in.) | 1123 (68.5)                             |                    |                    |  |
|                                     | Output                                      | SAE gross kW (HP)                       | 15.6 (20.9)        |                    |  |
|                                     |   | SAE Net kW (HP)                         | 14.8 (19.8)        |                    |  |
| Rated speed                         | rpm   | 2400                                    |                    |                    |  |
| Performance                         | Swing speed                                 | rpm                                     | 9.9                |                    |  |
|                                     | Travel speed                                | fast                                    | km/h (mph)         | 4.5 (2.8)          |  |
|                                     |   | slow                                    | km/h (mph)         | 2.5 (1.6)          |  |
|                                     | Ground pressure                             | kPa (kgf/cm <sup>2</sup> ) [psi]        | 23.7 (0.24) [3.44] | 24.7 (0.25) [3.58] |  |
|                                     | Climbing angle                              | % (deg)                                 | 27 (15)            |                    |  |
| Max. lateral sway                   | % (deg)                                     | 18 (10)                                 |                    |                    |  |
| Dozer (width & height) mm (in.)     |   | 1500 x300 (59 x 12)                     |                    |                    |  |
| Boom swing angle                    | Left  | rad (deg)                               | 1.31 (75)          |                    |  |
|                                     | Right                                       | rad (deg)                               | 0.96 (55)          |                    |  |
| Pressure connection for attachments | Max. displacement                           | L (US gal) / min                        | 48.0 (12.7)        |                    |  |
|                                     | Max. pressure                               | MPa (kgf/cm <sup>2</sup> ) [psi]        | 21.6 (220) [3133]  |                    |  |
| Fuel tank capacity                  |   | L (US gal)                              | 33 (8.72)          |                    |  |

**NOTE :**

- Above dimensions are based on the machine with JPN bucket.  
JPN = made in Japan
- Above dimensions are based on the machine with rubber crawlers.
- Specifications subject to change without notice.

# DESCRIPTION OF MACHINE PARTS

## [Canopy]

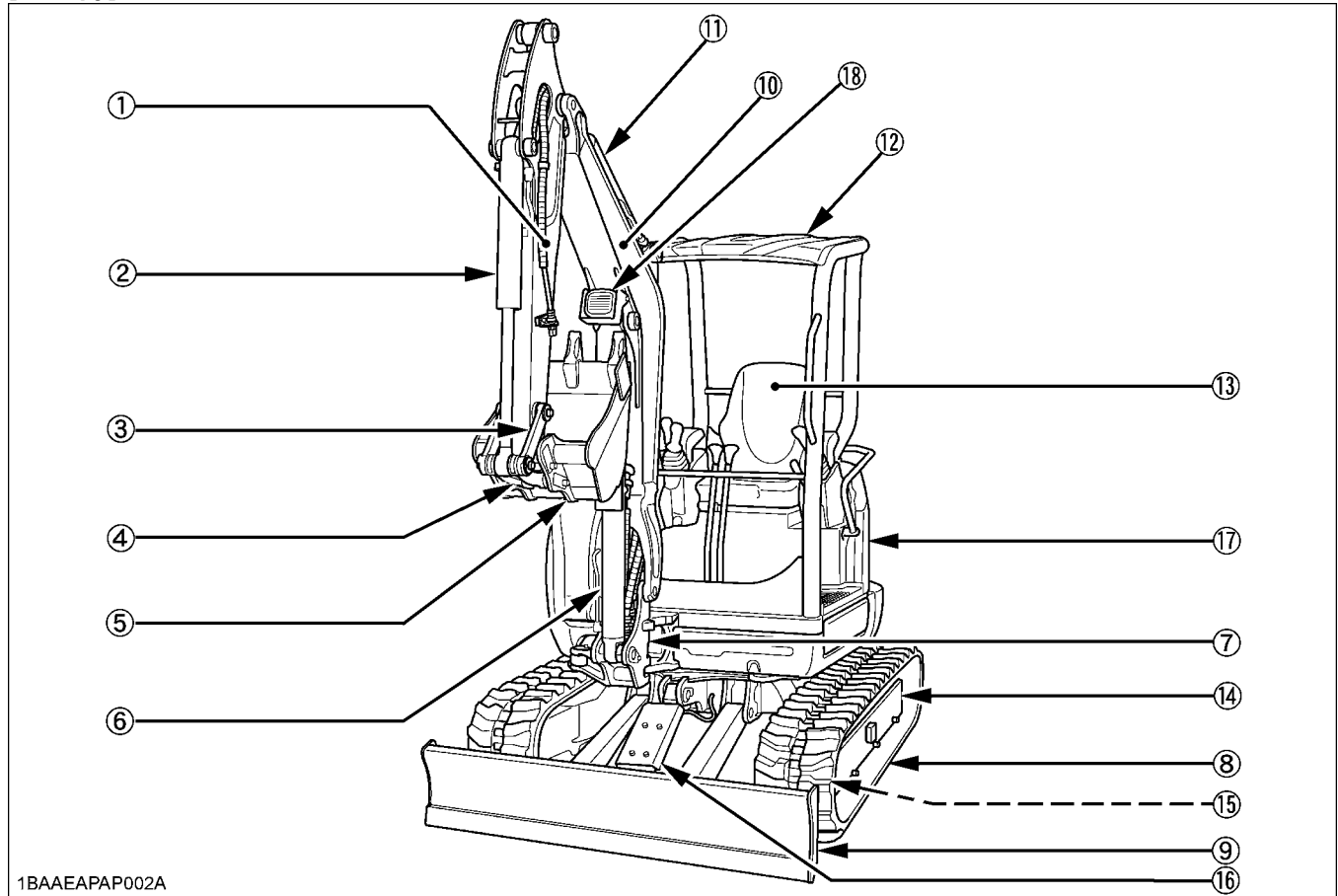

1BAAEAPAP002A

### DEPICTED CONTENTS

- (1) Arm
- (2) Bucket cylinder
- (3) Bucket link 2
- (4) Bucket link 1
- (5) Bucket
- (6) Boom cylinder
- (7) Swing bracket
- (8) Crawler
- (9) Dozer
- (10) Boom
- (11) Arm cylinder
- (12) ROPS
- (13) Operator's seat
- (14) Drive sprocket
- (15) Front idler
- (16) Dozer cylinder
- (17) Engine hood
- (18) Working light
- (19) Cabin

## [Cabin]

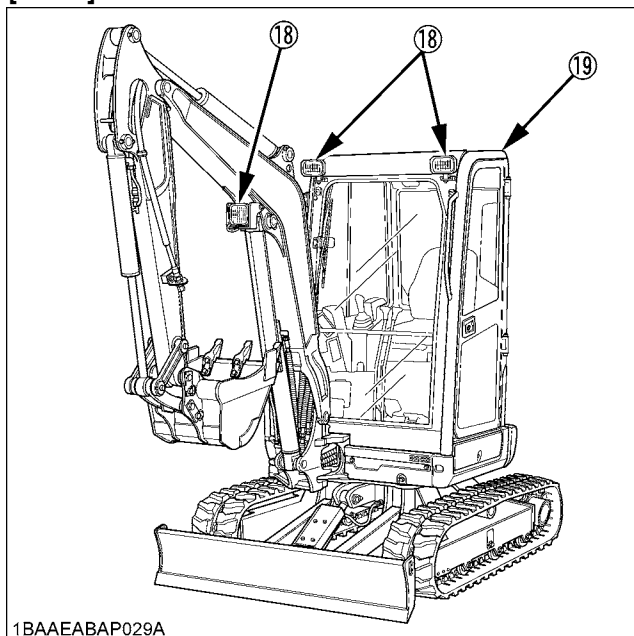

1BAAEABAP029A

# INSTRUMENT PANEL AND CONTROL ELEMENTS

## Switches

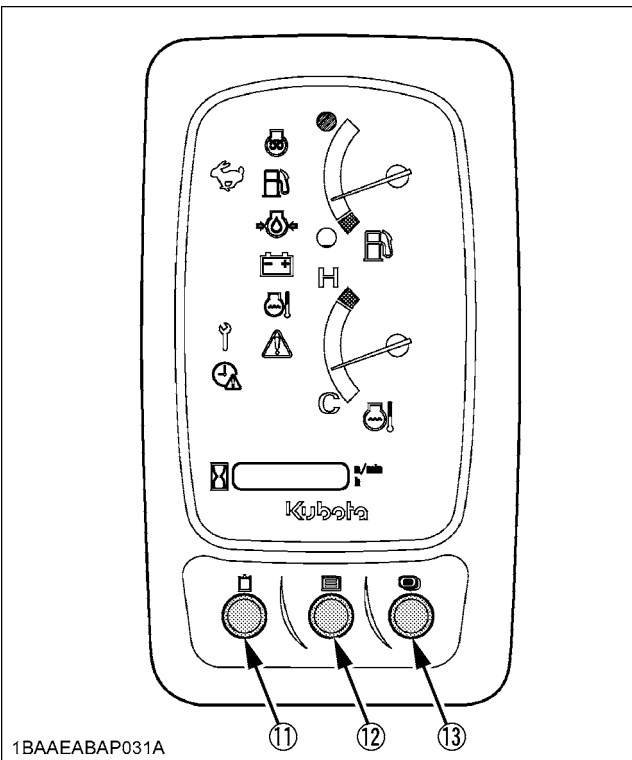
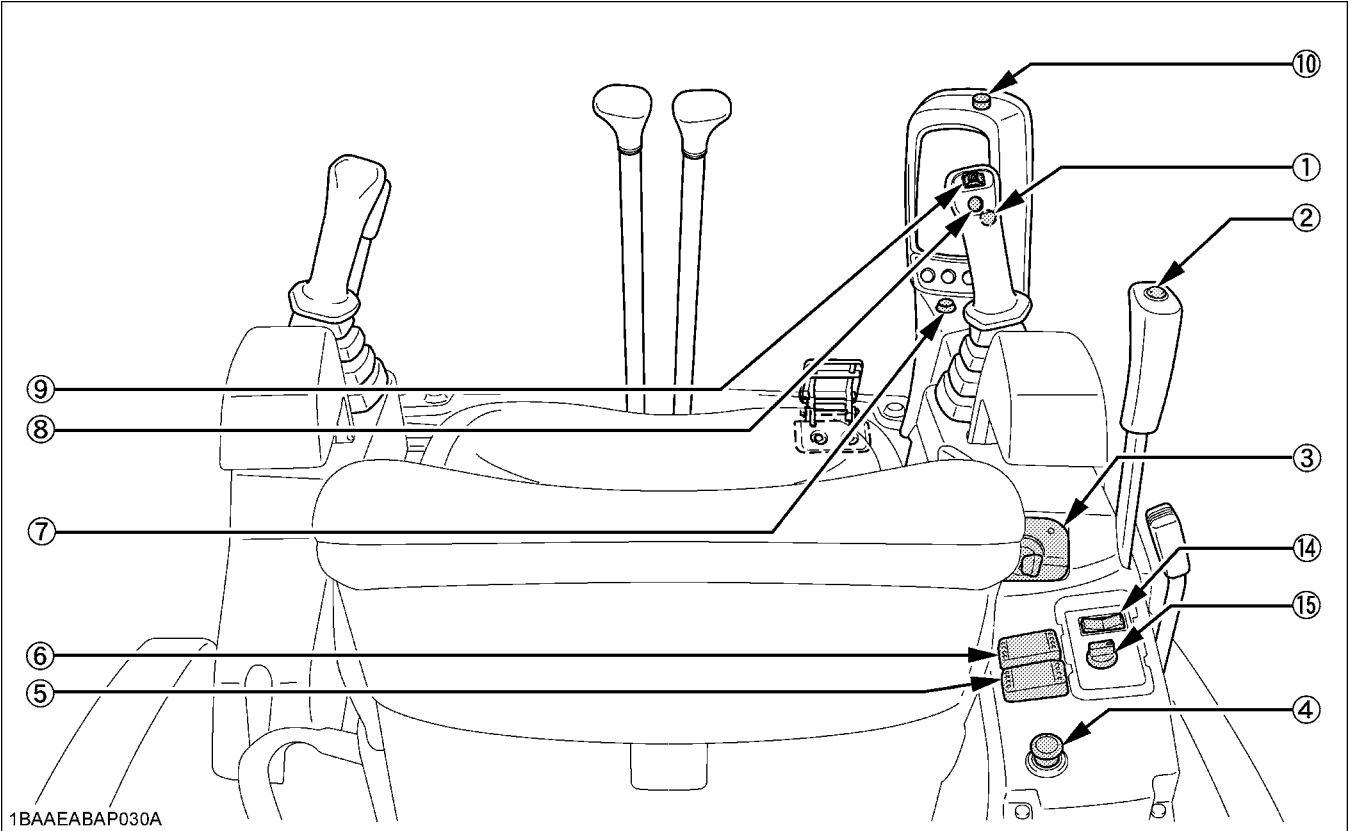

| DEPICTED CONTENTS                                     | Ref. page |
|---|-----------|
| (1) One way hold switch.....                          | 27        |
| (2) Travel speed switch.....                          | 30        |
| (3) Starter switch.....                               | 12        |
| (4) Engine stop button.....                           | 19        |
| (5) Beacon light switch.....                          | 22        |
| (6) Working light switch.....                         | 9, 22     |
| (7) Indicator for auxiliary port.....                 | 26        |
| (8) Horn switch.....                                  | 12        |
| (9) Rocker switch for auxiliary port.....             | 26        |
| (10) Potentiometer for auxiliary port.....            | 34        |
| (11) Enable switch for auxiliary port (switch 1)..... | 26        |
| (12) User setting switch (switch 2).....              | 13        |
| (13) Display selector switch (switch 3).....          | 13        |

**[Cab model]**

|                                 |   |
|---------------------------------|---|
| (14) Wiper / washer switch..... | 8 |
| (15) Heater switch.....         | 9 |

■ Control Pedals and Levers

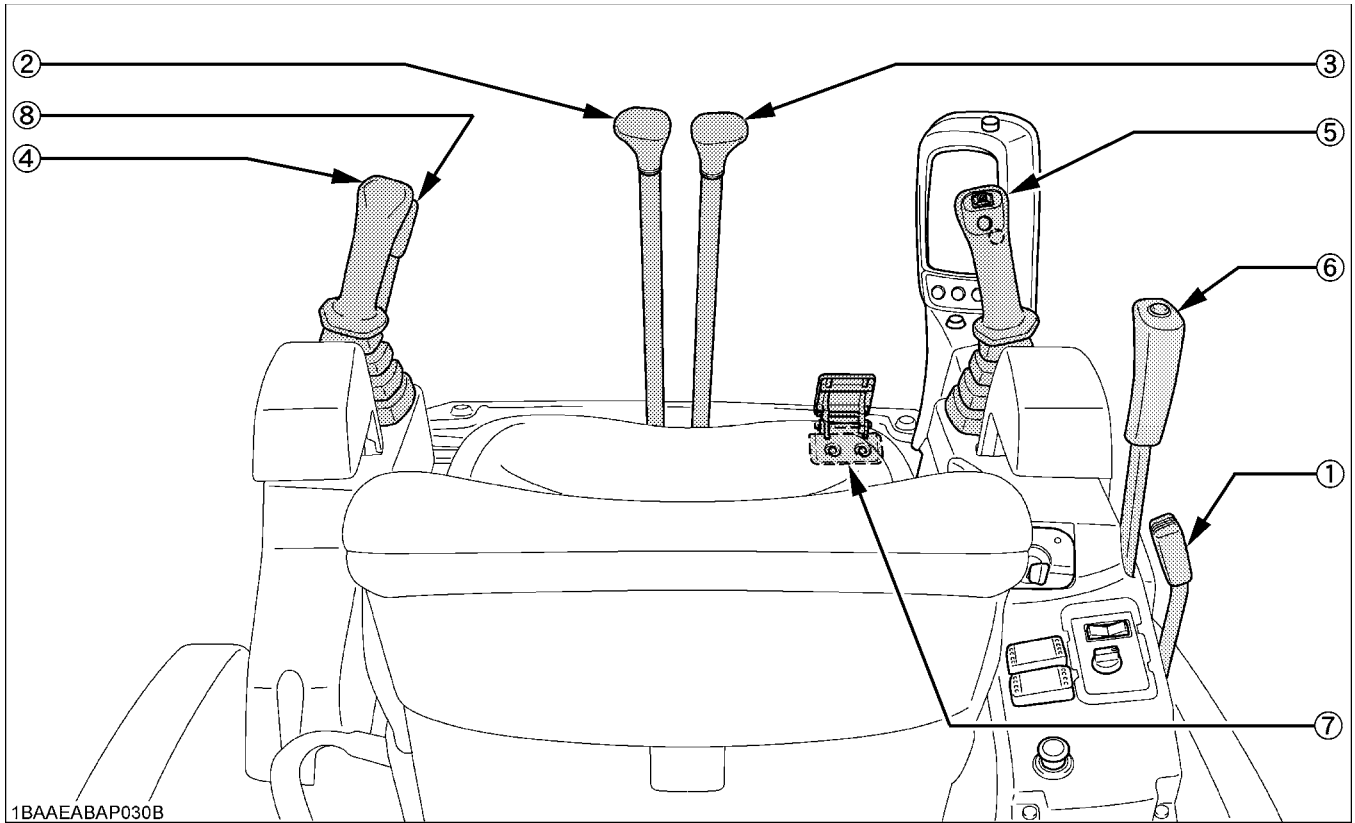

1BAAEABAP030B

| DEPICTED CONTENTS                                    | Ref. page  |
|--|------------|
| (1) Throttle lever.....                              | 29         |
| (2) Drive lever (left).....                          | 29         |
| (3) Drive lever (right).....                         | 29         |
| (4) Control lever for front attachments (left).....  | 24, 24, 25 |
| (5) Control lever for front attachments (right)..... | 24, 24, 25 |
| (6) Dozer control lever.....                         | 26         |
| (7) Boom swing pedal.....                            | 25         |
| (8) Pilot control lock lever *.....                  | 11         |

**IMPORTANT :**

\* Pulling up the pilot control lock lever prevents inadvertent machine movement.

■ Instrument Panel

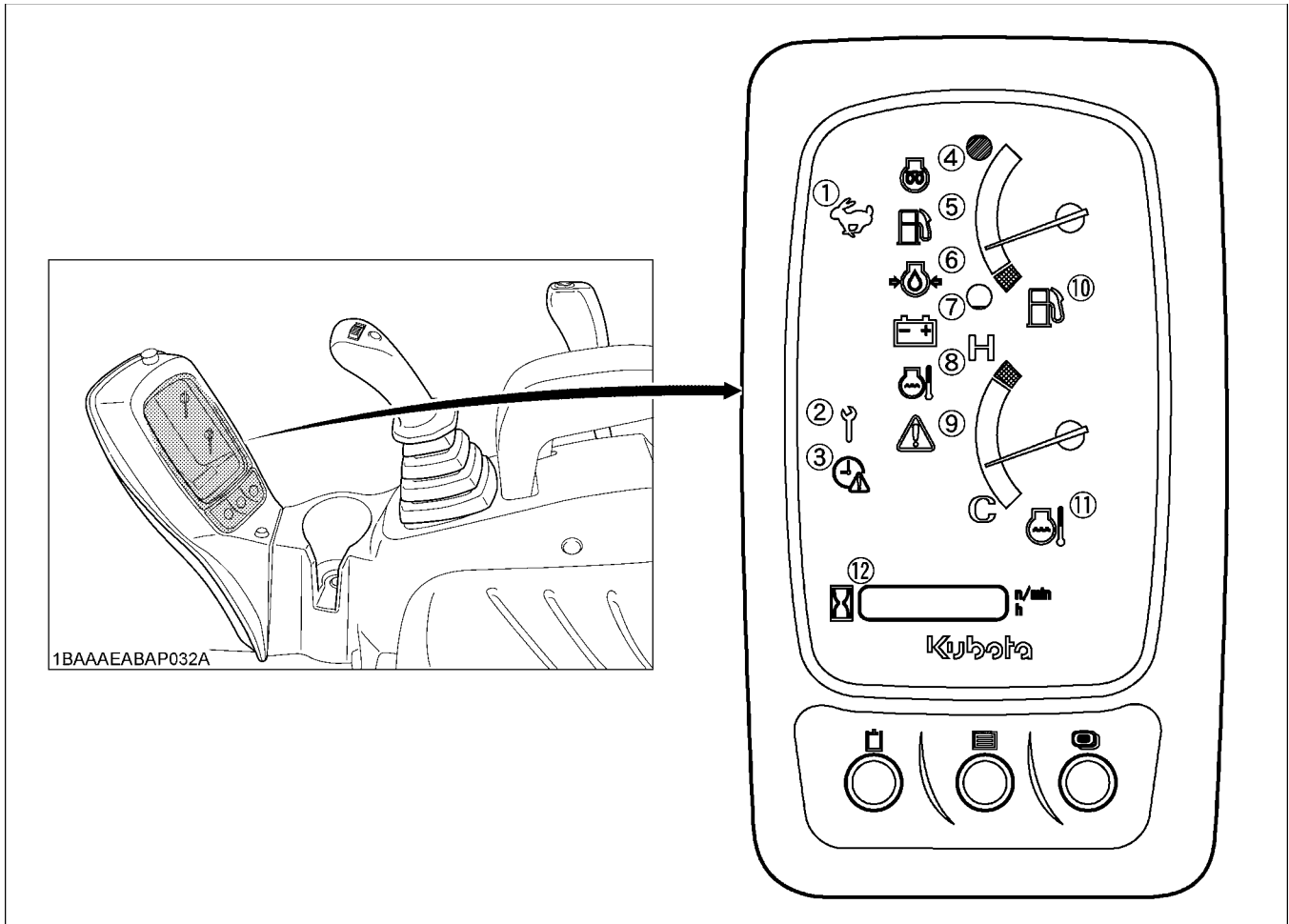

| DEPICTED CONTENTS                         | Ref. page |   | Ref. page |
|---|-----------|---|-----------|
| (1) Travel speed indicator lamp.....      | 30        | (7) Battery charge lamp.....              | 15        |
| (2) Periodic check lamp.....              | 66        | (8) Coolant temperature warning lamp..... | 16        |
| (3) Clock setting request lamp.....       | 13        | (9) Warning lamp.....                     | 17        |
| (4) Glow lamp.....                        | 15        | (10) Fuel gauge.....                      | 16        |
| (5) Remaining fuel warning lamp.....      | 16        | (11) Coolant temperature gauge.....       | 16        |
| (6) Engine oil pressure warning lamp..... | 15        | (12) LCD.....                             | 16        |

# CHECKS BEFORE START

## DAILY CHECKS

In order to avoid damage, it is important to check the condition of the excavator before starting.



### WARNING

To avoid personal injury or death:

- Do maintenance work on the excavator only on even ground with the engine off and the pilot control lock lever in the "LOCKED" position.

### Checks

Go around the excavator and check for visual damage and wear.

Check coolant level. (See "DAILY CHECKS" in "MAINTENANCE" section.)

Check fuel level.

Check engine oil level.

Check hydraulic fluid level.

Check air filter for clogging.

Check all greasing points.

Check all control lamps, indicators, revolution counter and hour meter.

Confirm all controls move freely and do not stick.

Check the light system.

Check the seat belt and the ROPS/OPG (Top Guard Level I) safety device.

Check the condition of the safety and warning labels. (See "DANGER, WARNING AND CAUTION LABELS" in "SAFE OPERATION" section.)

## CAB TYPE MACHINES

### ■ Wiper/Washer Switch

To move the wiper, turn on the switch for the wiper when the starter switch in position "RUN". A further push on the switch will activate the washer system. Even when the wiper switch is in position "OFF", the washer switch functions if it is pressed.

- Do not activate the washer switch if the tank for the cleaning fluid is empty; the pump can be damaged.
- Do not activate the wiper switch if the window is dry. In this case, make sure that cleaning fluid is applied to the pane before activating the wiper.
- In frosty conditions, make sure that the wiper blade is not frozen to the glass before switching-on. The motor can be damaged if the wiper system is used under such conditions.

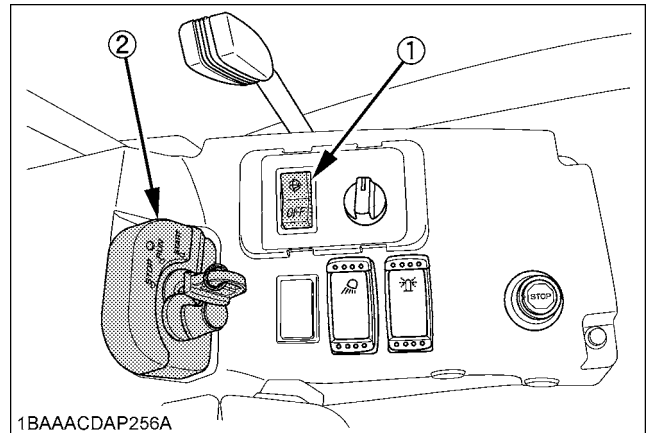

- (1) Wiper / Washer switch  
(2) Starter switch

### ■ Interior Lamp

To turn on the interior lamp, set the interior lamp switch to the "ON" position.

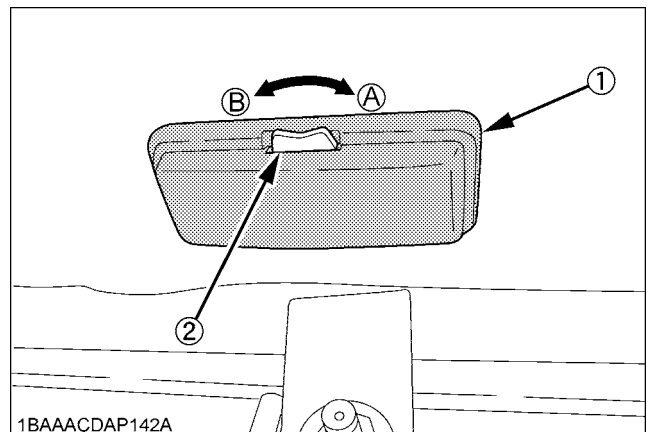

- (1) Interior lamp  
(2) Interior lamp switch  
(A) "ON"  
(B) "OFF"

**Working Light Switch**

To turn on the working light, set the starter switch to the "RUN" and then the working light switch to the "ON" positions, respectively.

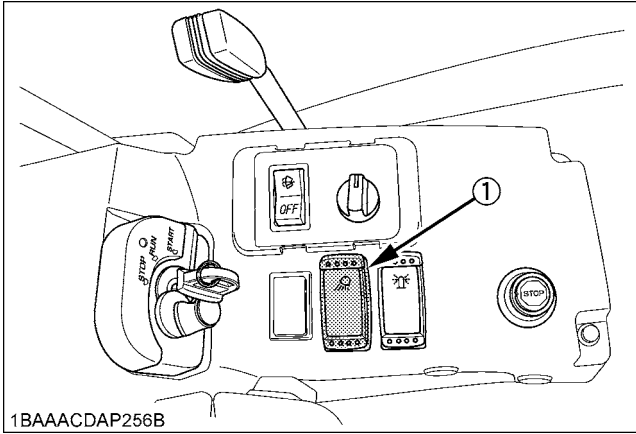

1BAAACDAP256B

(1) Working light switch

**Heater Switch**

Turn the starter switch to position "RUN" and turn the heater switch clockwise, the heater fan will be activated and the CAB will start to warm up. The heater has two positions - "Low" and "High" -.

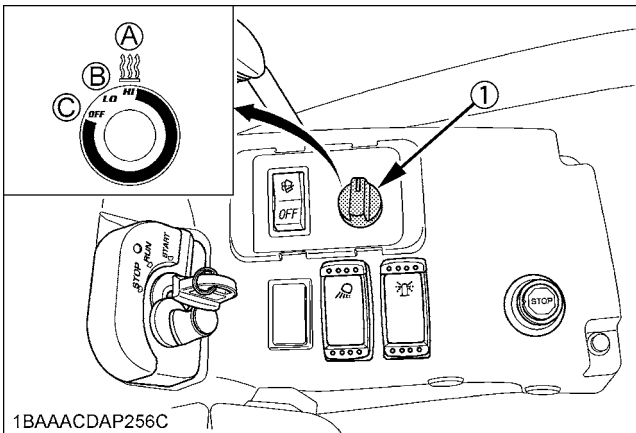

1BAAACDAP256C

(1) Heater switch

- (A) Pos. "High"
- (B) Pos. "Low"
- (C) Pos. "Off"

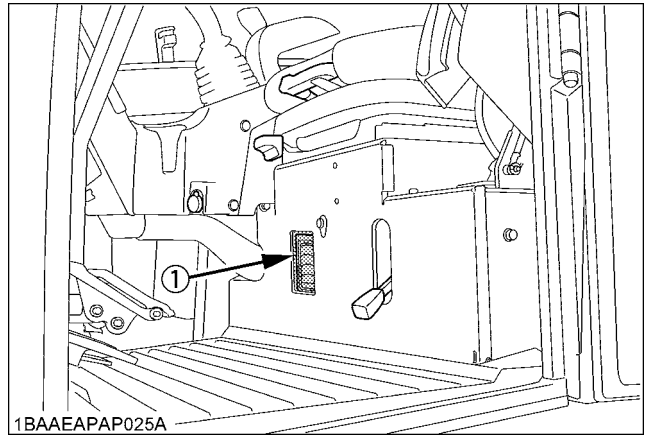

1BAAEAPAP025A

(1) Heater outlet

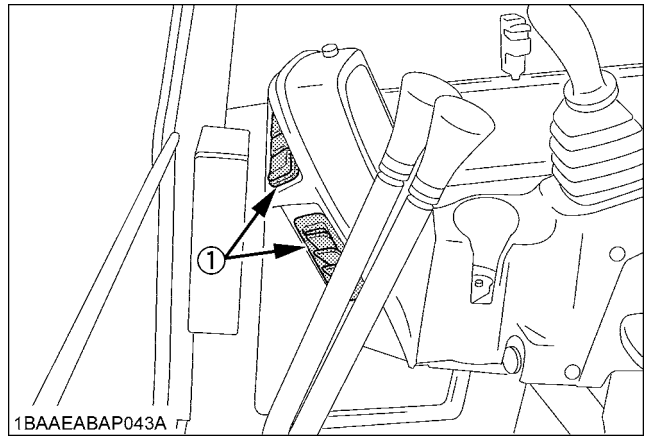

1BAAEABAP043A

(1) Heater outlet

**IMPORTANT :**

- During the summer, turn the heater valve clockwise to close the valve.

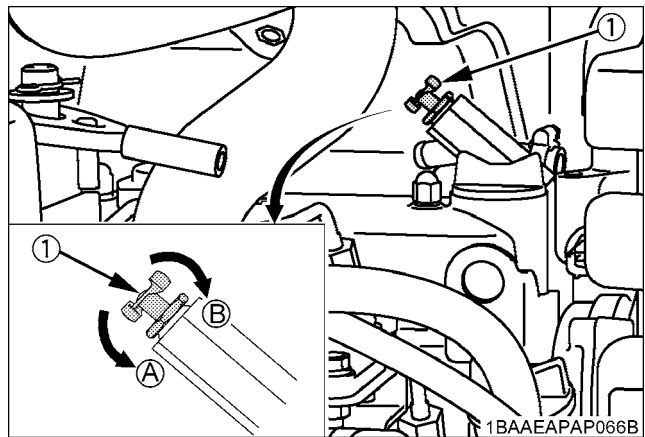



1BAAEAPAP066B

(1) Heater valve

- (A) Open
- (B) Close

◆ **Recirculation / Fresh Air Selection knob**

- **FRESH AIR:** Set the knob to the  position, and fresh air will flow into the CAB. This is helpful when you work in a dusty conditions or if the glass windows get foggy.
- **RECIRCULATION:** Set the knob to the  position, and the in-CAB air will be recirculated. This is useful for heating the CAB quickly or keeping it extra warm.

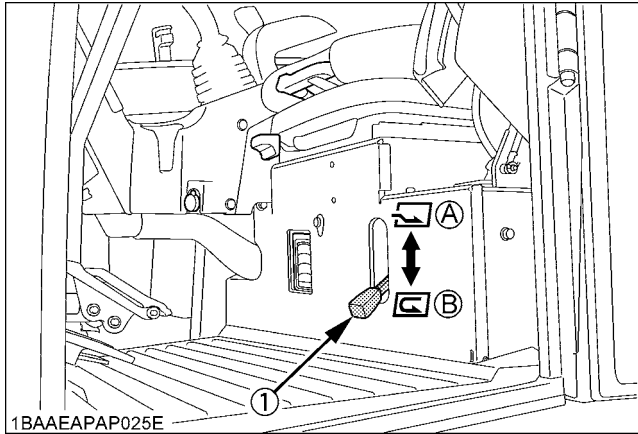

(1) Recirculation/ fresh air selection knob (A) "FRESH AIR" (B) "RECIRCULATION"

**NOTE :**

- When heating, do not keep the knob at the "RECIRCULATION" position for a long time. The windshield easily gets foggy.
- While working in a dusty condition, keep the knob at the "FRESH AIR" position.

■ **Opening/Closing of CAB Door**

1. Unlock the CAB door and pull the knob. Open the CAB door fully until fixed into place.
2. To close the CAB door, push the release lever down and close the door.

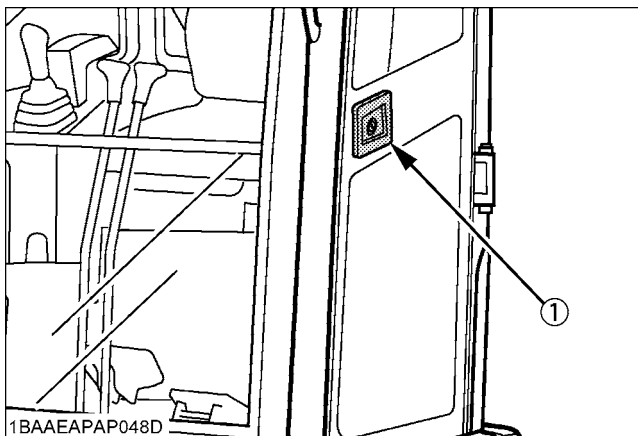

(1) Door knob (outside)

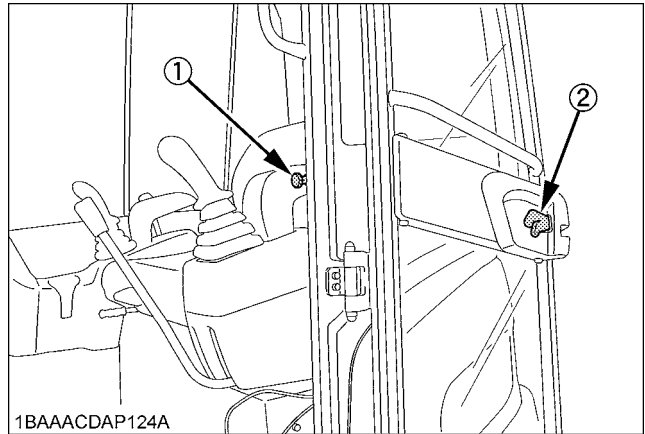

(1) Release lever (2) Door knob (inside)

3. When leaving the excavator, always lock the door.

■ **Opening/Closing of Front CAB Window**



**WARNING**

To avoid personal injury or death:

- Keep hands and feet away from the area between front window and CAB frame. Otherwise the operator risks serious pinching or crushing injuries.
- Other persons should stay away when opening the window.

To open and close the front window, take the steps below.

1. Push the lock levers beside grip.

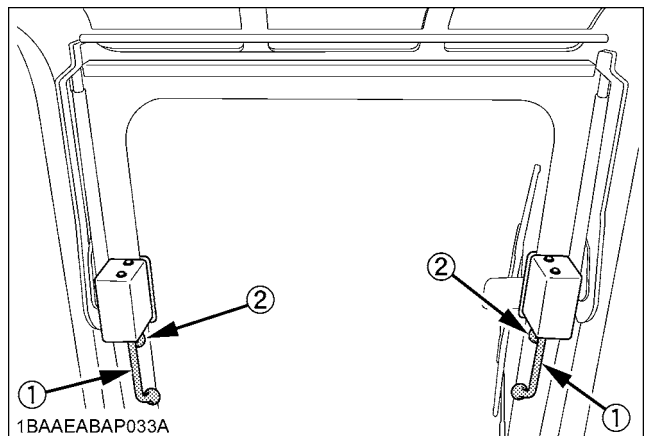

(1) Grip (2) Lock lever

2. Hold the grips tightly with both hands. Pull the grip slightly upward and toward yourself to let the windshield slide inward.
3. Pull the windshield all the way to the lock at the back of CAB.
4. To close the window, take the reverse steps 3, 2 and 1.



## ■ Opening/Closing of Side CAB Window

1. Pull the grip to release the lock and pull side window open to the rear or to the front.
2. To close the side window, slide it forward or backward until the lock snaps in at the window frame.

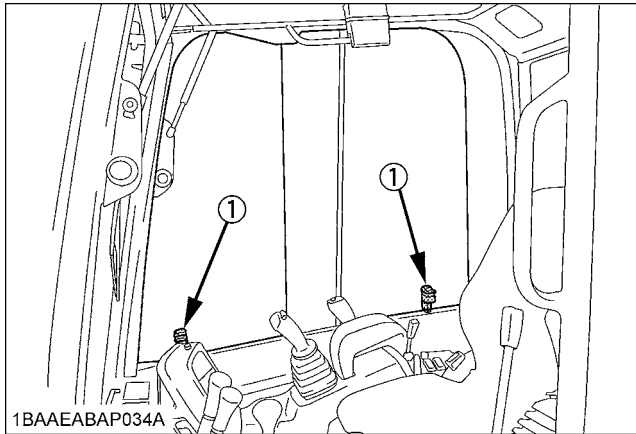

(1) Grip

## ■ Emergency Hammer



### WARNING

To avoid personal injury or death:

- When breaking the window pane, close your eyes and cover them with an arm.

The emergency hammer is for breaking rear window pane to escape from excavator should escape from the left side door, front window pane or right window pane is not possible.

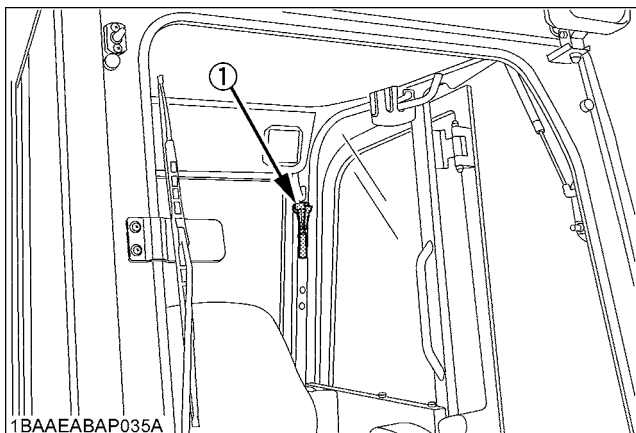

(1) Emergency hammer

## HANDLING THE SAFETY DEVICES

### ■ Pilot Control Lock Lever



### WARNING

To avoid personal injury or death:

- When the excavator is not used or left unattended, be sure to place the pilot control lock lever in position "LOCKED".

If the pilot control lock lever is raised in position "LOCKED" completely, then the hydraulic functions of the following controls will be locked.

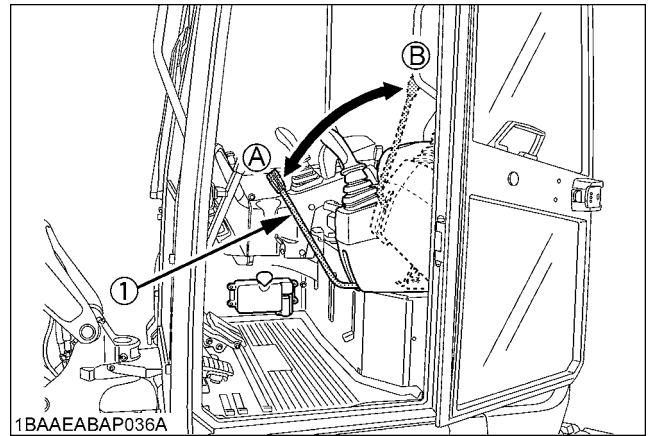

(1) Pilot control lock lever

(A) "UNLOCK"  
(B) "LOCKED"

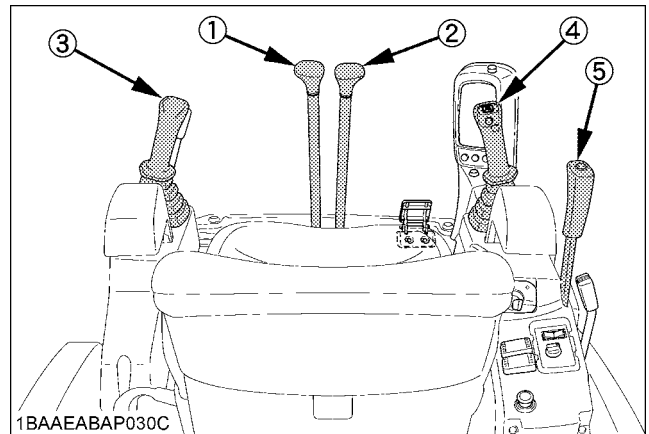

- (1) Drive lever (Left)
- (2) Drive lever (Right)
- (3) Control lever for attachments (Left)
- (4) Control lever for attachments (Right)
- (5) Dozer control lever

# OPERATION OF THE ENGINE



## WARNING

To avoid personal injury or death:

- Read "SAFE OPERATION" at the beginning of this operator's manual.
- Obey the danger, warning and caution labels on the excavator.
- To avoid the danger of exhaust fume (carbon monoxide) poisoning, do not operate the machine in a closed building without proper ventilation.
- Always start the engine from the operator's seat. Do not start the engine while standing next to the excavator. Before starting the engine, sound the horn to get the attention of persons standing nearby.

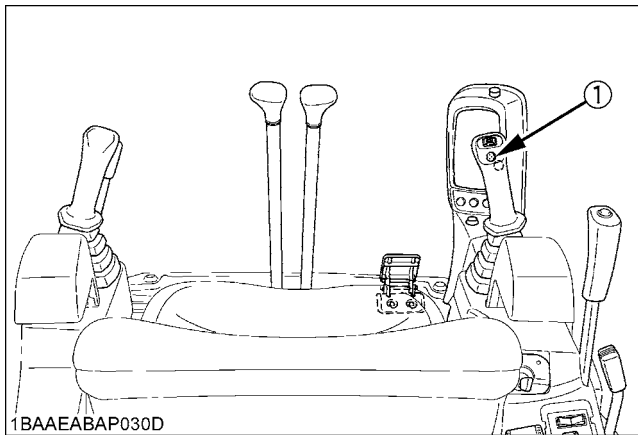

1BAAEABAP030D

(1) Horn switch

### IMPORTANT :

- Do not use starting fluid or ether.
- In order not to overload the battery and starter, avoid engaging the starter more than 10 sec.
- When engine does not start in 10 sec., please wait 20 sec. or more, before attempting to restart.

## STARTING THE ENGINE



## WARNING

To avoid personal injury or death:

- The operator should not depend solely on the warning lamps, but should always conduct the routine checks (see "MAINTENANCE").

Start the engine in the following manner:

1. Before starting the engine, make sure that all control levers are in the neutral positions.

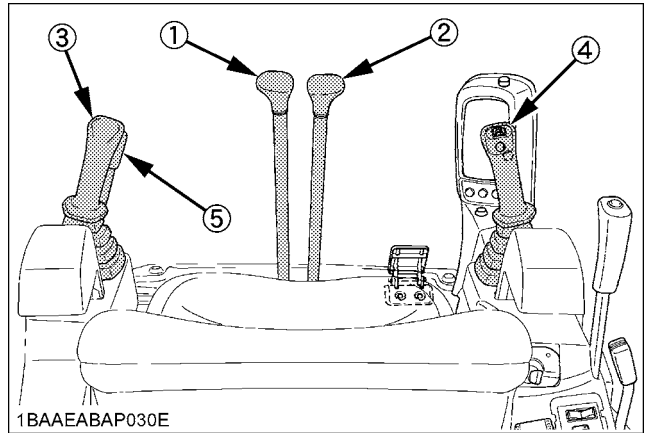

1BAAEABAP030E

- (1) Drive lever (left)
  - (2) Drive lever (right)
  - (3) Attachment control lever (left)
  - (4) Attachment control lever (right)
  - (5) Pilot control lock lever
2. Pull the pilot control lock lever all the way back. ("LOCKED" position)
    - Put the throttle lever towards the "SLOW" position.

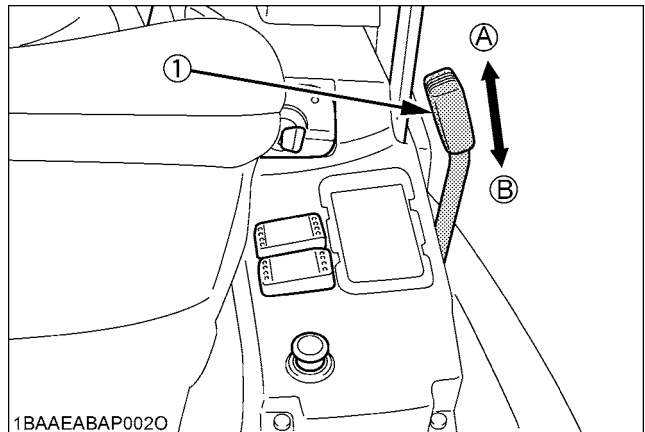

1BAAEABAP002O

- (1) Throttle lever
- (A) "FAST"
- (B) "SLOW"

3. Insert the key into the starter switch and turn it to the position "RUN". The glow lamp indicator will light up while the engine is preheated and will go out automatically after preheating is finished.

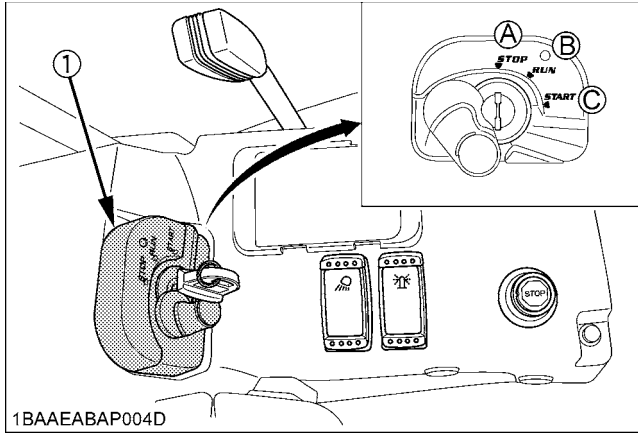

(1) Starter switch  
 (A) "STOP"  
 (B) "RUN"  
 (C) "START"

4. Turn the key to the position "START" and release after the engine has started.
5. Check if oil lamp and charge lamp have gone out. Should a warning lamp still be lit up, stop the engine then remove the key and check for the cause.

**NOTE :**

- When the pilot control lock levers are in "UNLOCK" position, the engine does not start.

**■ Display Selector Switch**

Press the display selector switch. The electronic meter's LCD will change from one indication mode to the other. Change the three-mode display according to your jobs.

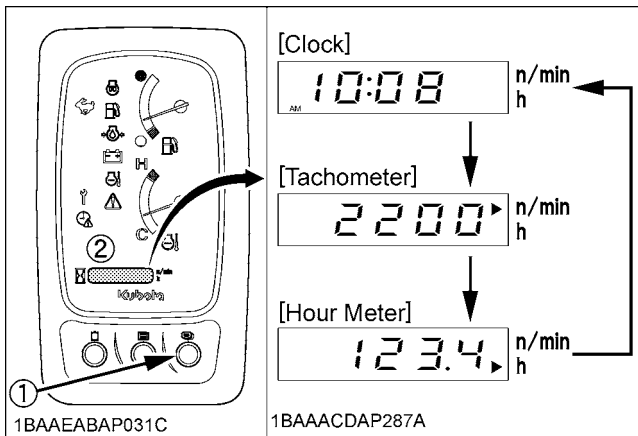

(1) Display selector switch  
 (2) LCD

**NOTE :**

- With the starter key at the "STOP" position, press the electronic meter's display selector switch, and the LCD shows the hour meter, fuel gauge and water temperature gauge for 10 seconds.

**◆ Setting the clock**

**[Selecting the clock setting mode]**

1. Press the user setting switch (switch 2).
2. Select the clock setting mode by pressing the display selector switch (switch 3) and the clock setting request lamp "⌚" on the instrument panel lights up.

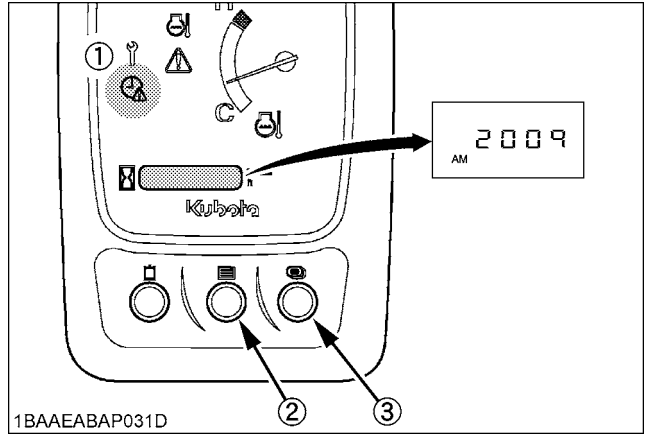

(1) Clock setting request lamp  
 (2) User setting switch (switch 2)  
 (3) Display selector switch (switch 3)

**NOTE :**

- Press switch 3 for a long time and the year, month, day, hour and minute will be selected in this order.

**[Setting the year]**

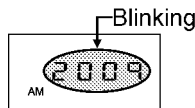

Press switch 2 and the numeric setting will be smaller.  
 Press switch 3 and the numeric setting will be larger.

| Switch 2 | Switch 3 |
|----------|----------|
| 2008     | 2010     |
| ↓        | ↑        |
| 2007     | 2009     |
| ↓        | ↑        |
| 2006     | 2008     |

**NOTE :**

- While setting the clock, the clock setting request lamp "⌚" on the instrument panel is blinking.

**[Setting the month]**

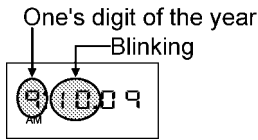

Press switch 2 and the numeric setting will be smaller.  
Press switch 3 and the numeric setting will be larger.

| Switch 2 | Switch 3 |
|----------|----------|
| 10       | 11       |
| ↓        | ↑        |
| 9        | 10       |
| ↓        | ↑        |
| 8        | 9        |

**[Setting the day]**

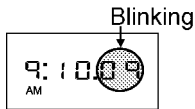

Press switch 2 and the numeric setting will be smaller.  
Press switch 3 and the numeric setting will be larger.

| Switch 2 | Switch 3 |
|----------|----------|
| 09       | 11       |
| ↓        | ↑        |
| 08       | 10       |
| ↓        | ↑        |
| 07       | 9        |

**[Changing the AM/PM system to the 24-hour system]**

Select the AM/PM system or 24-hour system by pressing switch 3.

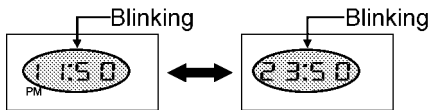

**[Setting the hour]**

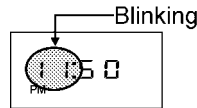

Press switch 2 and the numeric setting will be smaller.  
Press switch 3 and the numeric setting will be larger.

| Switch 2 | Switch 3 |
|----------|----------|
| 11       | 12       |
| ↓        | ↑        |
| 10       | 11       |
| ↓        | ↑        |
| 9        | 10       |

**[Setting the minute]**

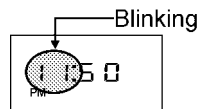

Press switch 2 and the numeric setting will be smaller.  
Press switch 3 and the numeric setting will be larger.

| Switch 2 | Switch 3 |
|----------|----------|
| 50       | 52       |
| ↓        | ↑        |
| 49       | 51       |
| ↓        | ↑        |
| 48       | 50       |

If switch 3 is pressed for a long time, the new settings will be made.

**NOTE :**

- If the battery is disconnected, the clock setting request lamp "Ⓜ" (yellow) will blink for requesting the setting the clock.

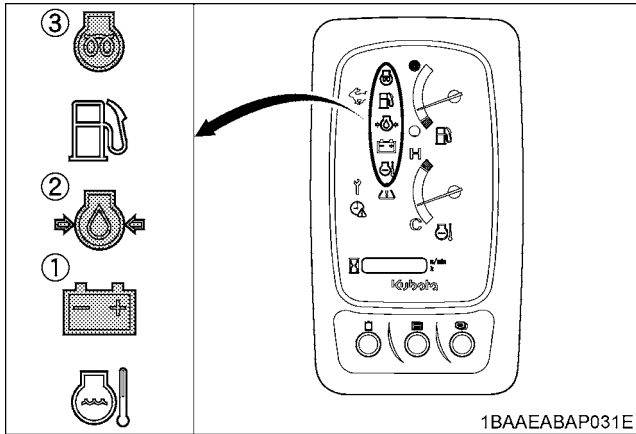

- (1) Battery charge lamp  
 (2) Engine oil pressure warning lamp  
 (3) Glow lamp

### ■ Battery Charge Lamp

This warning lamp lights up if the charging system fails with the engine running. When the starter switch is turned to **"RUN"** with the engine off, the lamp lights up, and when the engine starts, the lamp goes out. If the lamp stays on with the engine running, stop the engine and check the fan belt.

#### NOTE :

- If there is disconnection or failure in the charging system when the key is turned to **"RUN"**, the following symbol will appear.

### ■ Engine Oil Pressure Warning Lamp

The engine oil pressure warning lamp lights up due to failure of the lubricating system with the engine running. When the starter switch is turned to **"RUN"** with the engine off, this lamp lights up, and when the engine starts, the lamp goes out. If the lamp stays on with the engine running, stop the engine and check the engine oil level.

#### NOTE :

- If there is disconnection, failure or breakdown in the lubricating system when the key is turned to **"RUN"**, the following symbol will appear.

### ■ Glow Lamp

With the starter key at the **"RUN"** position, the engine's preheat status is indicated.

#### NOTE :

- When the starter switch is turned to the **"RUN"** position, the engine will be preheated for a given period of time and the indicator will turn on.
- The above indication appears momentarily when the engine is started, but it does not indicate trouble. (This is because the oil charge sensor output fluctuates when the engine is started.)
- The following symbol appears momentarily as the engine starts. This is not an error.

■ LCD for Normal Operation

◆ Fuel gauge

**WARNING**

To avoid personal injury or death:

- Before adding fuel, be sure to stop the engine.
- Be sure to keep open flame away from the machine. Otherwise a fire may result.

If the fuel in the tank goes below the prescribed level, the warning lamp will flash.

If this should happen during operation, refuel as soon as possible.

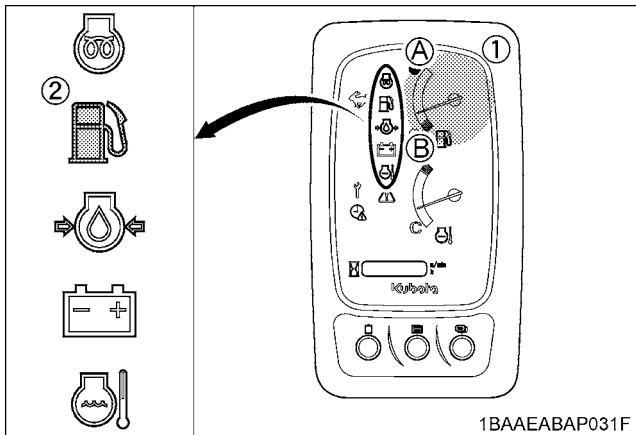

- (1) Fuel gauge (A) "FULL"  
 (2) Remaining fuel warning lamp (B) "EMPTY"

**IMPORTANT :**

- If the fuel gauge indicator is near the "○", add fuel as soon as possible. If the indicator is near "○" and the machine operates on a slope, the engine may run out of fuel.

◆ Coolant Temperature Gauge

**WARNING**

To avoid personal injury or death:

- Do not open the radiator cap during or just after operation. Hot coolant may gush out and scald you. Wait for the coolant to cool down before opening the cap.

With the starter key at the "RUN" position, the cooling water temperature is indicated.

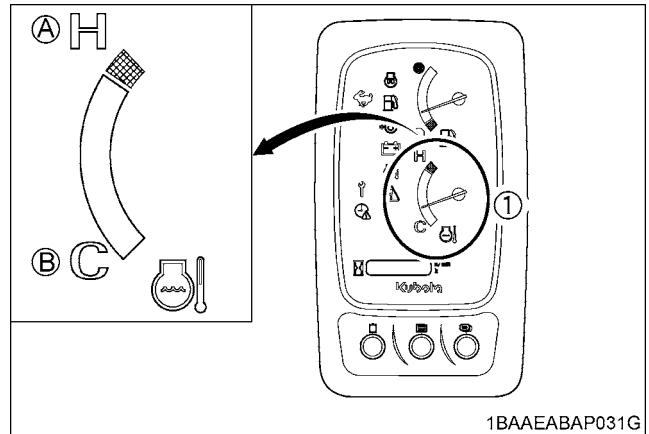

- (1) Coolant temperature gauge (A) "HOT"  
 (B) "COOL"

◆ Hour-meter

Indicates the total operating hours of the machine.

How the indicator works

- The meter advances one hour after an hour of operation regardless of the engine rpm.

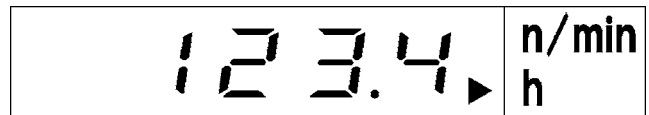

1BAAACDAP288A

◆ Engine tachometer

Indicates the current rpm of the engine.

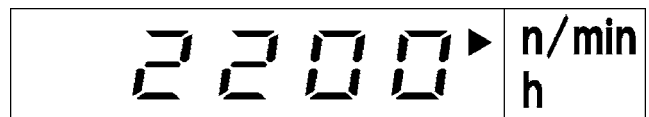

1BAAACDAP098A

**NOTE :**

- The LCD may be illegible when viewed from a certain angle. This is not a display failure.

**■LCD for Warning**

**◆ Engine oil pressure warning lamp**

The engine oil pressure warning lamp lights up due to failure of the lubricating system with the engine running. When the starter key is turned to "RUN" position with the engine off, this engine oil pressure lamp lights up, warning lamp blinks and when the engine starts, the lamps go out. If the lamp stays on with the engine running, stop the engine and check the engine oil level.

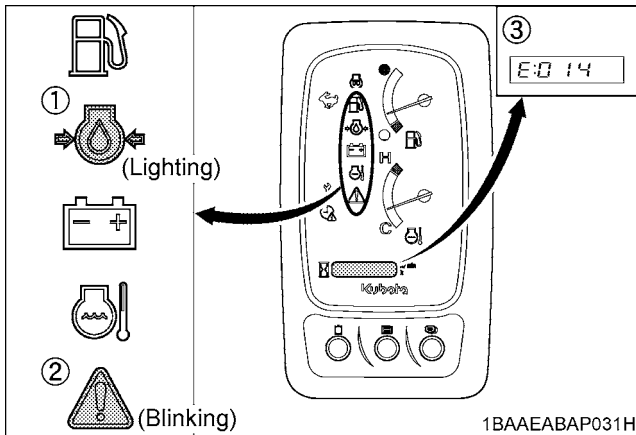

- (1) Engine oil pressure lamp
- (2) Warning lamp (red)
- (3) Warning message

**◆ Battery charge lamp**

This battery charge lamp lights up if the charging system fails with the engine running. When the starter key is turned to "RUN" position with the engine off, the battery charge lamp lights up, warning lamp blinks and when the engine starts, the lamps go out. If the lamp stays on with the engine running, stop the engine and check the V-belt.

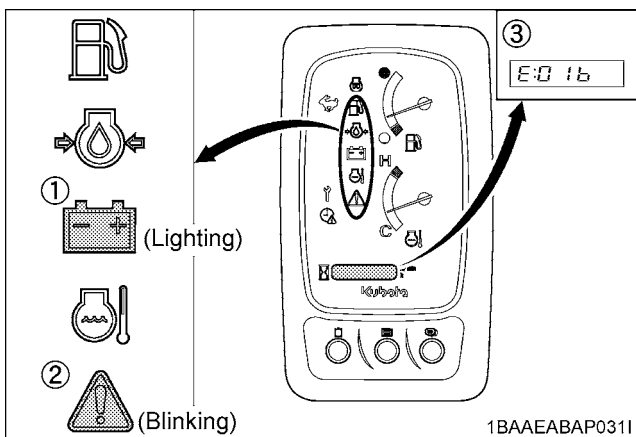

- (1) Battery charge lamp
- (2) Warning lamp (red)
- (3) Warning message

**■Warning Lamp**

The warning lamp is used to indicate broken wire, short-circuit, fuel shortage and other problems.

**IMPORTANT :**

- Do not just look at the meter, but also carry out the inspection and correction accordingly.

**NOTE :**

- The warning lamp starts flashing in red if a serious problem occurs. If the system gets in warning signal, the warning lamp starts flashing in yellow.
- Warnings and errors are displayed and an alarm buzzer beeps.
- Let your KUBOTA dealer inform you of details concerning care and maintenance.

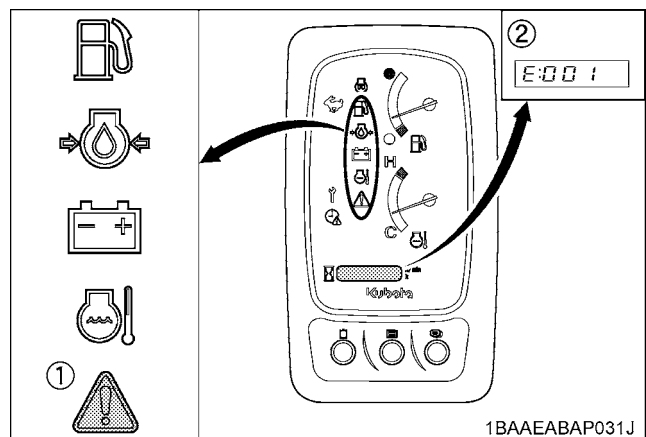

- (1) Warning lamp
- (2) Warning message

### ◆ Overheat warning

1. If the coolant temperature becomes elevated, the coolant temperature warning lamp blinks and the warning message (E: 015) appears on LCD. The message fades out after a short time and the coolant temperature warning lamp blinks as long as the temperature remains elevated. Operate the machine only with reduced loads until the operating temperature is normal again.

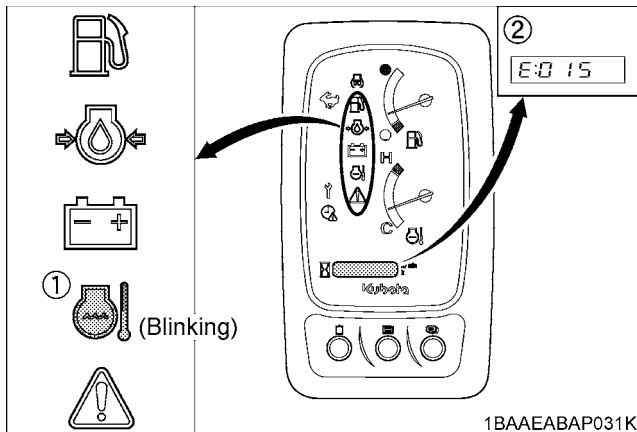

- (1) Coolant temperature warning lamp  
(2) Warning message

### ■ Checkpoints after Starting the Engine

After starting the engine, but before starting operation, check the following points:

1. Put the throttle lever in position "SLOW" and let the engine idle for approx. five minutes. This allows the engine lubricant to warm up and penetrate every part of the engine.

#### NOTE :

- This idling is usually called "Warm-up".
- 2. Once the engine has warmed up, check:
  - the warning lamp "Engine oil pressure" has gone out.
  - the warning lamp "Battery charge" goes out when engine speed is increased.
  - the color of the exhaust is normal and no abnormal noises or vibrations are heard or felt.
  - no fluid is leaking from pipes or hoses.

### ◆ Should any following conditions occur, stop the engine immediately.

- The engine rpm's increases or decreases suddenly.
- Sudden abnormal noises are heard.
- Exhaust is black.
- Warning lamp for engine oil lights up during operation.

#### IMPORTANT :

- In these cases, the excavator must be checked and serviced by your local the KUBOTA dealer.

## STARTING THE ENGINE UNDER COLD CONDITIONS



### WARNING

To avoid personal injury or death:

- Make sure that the pilot control lock lever is in the "LOCKED" position during warm up.

#### Start the engine in the following manner;

1. Pull the pilot control lock levers all the way back (lock position).
2. Turn the starter switch to the position "RUN" (glow position) and keep until the indicator lamp has gone out.
3. Move the starter switch to the position "START" to crank and start engine.
4. Release the starter switch after the engine has started; it will automatically return to the position "RUN".

#### IMPORTANT :

- Let the engine warm up after start-up for approx. 10 minutes under no load conditions. If the hydraulic fluid temperature is too low, the operation will be affected. Do not operate the excavator under full load until the engine has sufficiently warmed up.

### ■ Precautions in case of Overheat



### WARNING

To avoid personal injury or death:

- Do not open the radiator cap during operation or just after shut-down. Otherwise, steam or very hot coolant may gush out, getting you scalded. Make sure the radiator has cooled down enough before opening its cap.

If coolant gets heated up to the boiling point or over (overheated), take the following steps.

1. Stop operation in a safe position.  
(Disconnect the engine's load.)
2. Do not stop the engine suddenly. Keep the engine idling under no load for about 5 minutes and then turn it off.
3. Keep yourself enough away from the machine for another 10 minutes or while steam is emitting.
4. Make sure there is no hazard of getting burned. Check and remove the cause of overheat, referring to "TROUBLESHOOTING". Then restart the engine.



## STOPPING THE ENGINE



### WARNING

To avoid personal injury or death:

- Do not keep the bucket or dozer in the lifted position, as a person could accidentally touch the levers and cause serious accidents.

1. Place the bucket and dozer on the ground.
2. After slowing the engine to idle, turn the key to "STOP".
3. Remove the key.
4. Pull the pilot control lock lever to "LOCKED" position.

### ■ Engine Stop Button



### WARNING

To avoid personal injury or death:

- Keep hands away from rotating parts.

#### IMPORTANT :

- Be sure to return the stop button to former position after the engine stops.

The engine stops when the key is turned off. If the engine does not stop, pull back the stop button and hold it until the engine stops.

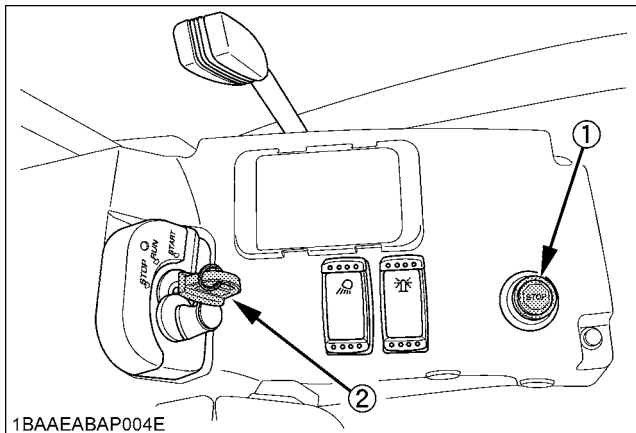

(1) Stop button

(2) Starter key

## STARTING WITH AN AUXILIARY BATTERY



### WARNING

To avoid personal injury or death:

- Battery gases can explode.  
Do not smoke and keep sparks and flames away.
- Do not start the engine with an auxiliary battery if excavator battery is frozen.
- Do not connect the black jumper cable to the negative (-) terminal of the excavator battery.

### ■ Observe Following Guidelines when Starting with an Auxiliary Battery

1. Bring the helping machine with the same battery voltage as near as possible to the excavator. THE MACHINES MUST NOT COME IN CONTACT WITH EACH OTHER.
2. Bring the levers and pedal of both vehicles in the neutral position and put the pilot control lock lever in the "LOCKED" position.
3. Wear eye protection and rubber gloves.
4. Open the side cover. (See "Opening/Closing of the Side Cover" in "MAINTENANCE" section.)
5. Ensure the vent caps are securely in place (if equipped).
6. Connect the terminal of the red jumper cable with the plus (+) terminal of the low battery and connect the other end of the cable to the plus (+) terminal of the auxiliary battery.
7. Connect the black negative cable to the minus (-) terminal of the auxiliary battery.
8. Connect the other end of the black cable (coming from the auxiliary battery) to the excavator frame as far away as possible from the low battery.
9. Start the engine of the helping machine and let it run for a while. Start the excavator with the low battery.
10. Disconnect the jumper cables in the reverse sequence (Steps 8, 7, 6).

11. Replace the vent caps.

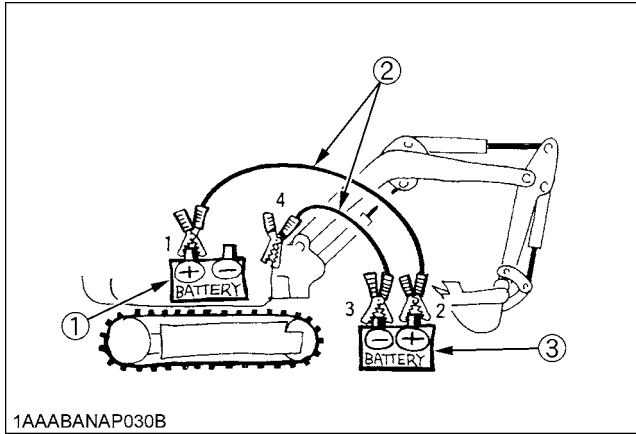

- (1) Low battery
- (2) Jumper cables
- (3) Auxiliary battery

**IMPORTANT :**

- This excavator has a negative (-) ground 12 Volt starting system.
- Use only the same voltage when using an auxiliary battery.
- Using a higher voltage will cause serious damage to the electrical system. When using an auxiliary battery, only the compatible (same) voltage is permissible.

# EXCAVATOR OPERATION

## RUNNING-IN OF THE NEW EXCAVATOR

The operation and care of the new excavator influences its life span. Your new excavator has been carefully checked and tested before leaving the factory. In spite of this, all movable components must run-in during the first 50 work hours. Do not work with full rpm's and full loads during this period. It is most important to run-in your excavator properly in order to achieve its full performance and longevity. During the running-in, the following points should be adhered to in all cases.

### ■ Do not Work with Full Engine Rpm's or Full Loads during the First 50 Working Hours

- Let the engine warm up sufficiently in the cold season.
- Do not let the engine rev-up more than necessary.

### ■ Oil Change in the Run-in Stage

The lubrication oil plays a specific and important role during the run-in phase of the excavator. The numerous movable parts are not yet run-in, so many fine metal particles are generated and cause damage and shorten the life of many components. Pay attention to the oil-change intervals and complete them sooner than later. See "REGULAR CHECKS AND MAINTENANCE WORK" section for more details on the oil-change intervals.

### ■ Seat Belt



## WARNING

To avoid personal injury or death:

- Always use the seat belt with a ROPS/OPG (Top Guard Level I) protection structure. Adjust the seat to the optimal position and buckle up.

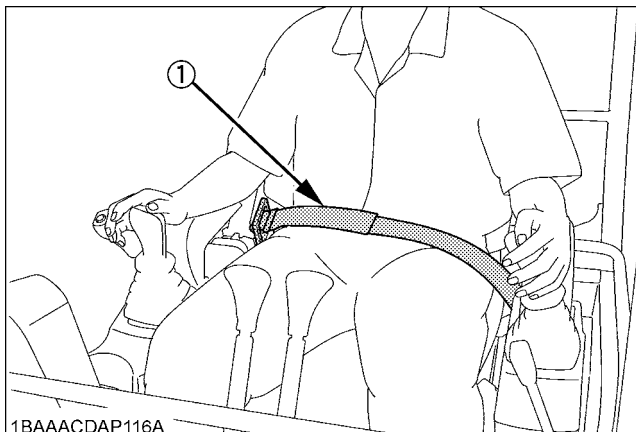

1BAAACDAP116A

(1) Seat belt

## STARTING

### 1. Adjusting the Operator's Position.

#### ■ Operator's Seat



## WARNING

To avoid personal injury or death:

- Make sure that the seat is completely secured after each adjustment.
- Do not allow any person other than the driver to ride on the excavator.

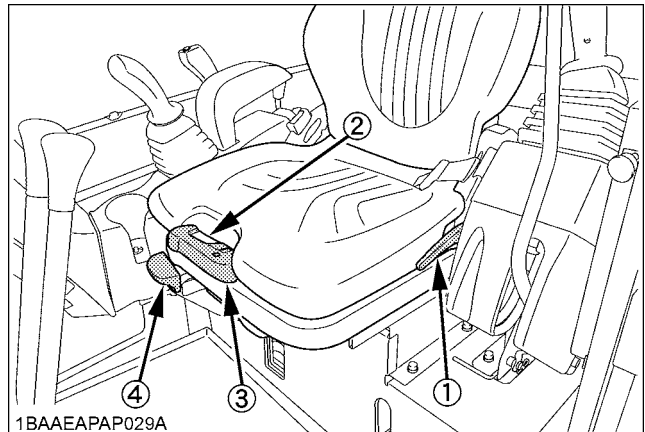

1BAAEAPAP029A

- (1) Backrest adjustment lever
- (2) Weight indicator
- (3) Spring adjustment lever
- (4) Horizontal seat adjustment lever

#### ◆ Horizontal seat adjustment (seat stand-off)

Pull the horizontal seat adjustment lever up and move the seat to the desired position by moving it forward or back, then release the lever.

#### IMPORTANT :

- Check that the seat is locked into place.

#### ◆ Spring adjustment (driver's weight)

1. The seat can be set to the weight of the driver with the lever. The weight indicator is provided as an adjustment aid.
2. Pressing down the lever increases the spring tension (suitable for heavier operators), pulling the lever upward reduces spring tension (for lighter operators).
3. Adjust the seat so that a comfortable cushioning is achieved.

◆ **Backrest adjustment**

Take the load off the backrest and pull up the backrest adjustment lever. Set the backrest to the desired sitting position and release the lever. The backrest should be adjusted so that the operator can safely operate the control levers with the back resting completely on the backrest.

2. **After starting the engine, bring the pilot control lock lever into the "UNLOCK" position to use drive lever or control lever for front attachments.**

■ **Pilot Control Lock Lever**



**WARNING**

To avoid personal injury or death:

- To avoid injuries, check safety aspects all around the excavator.

**NOTE :**

- If the pilot control lock lever is pulled down, the engine will fail to start.

If you try to start the engine with the key with the pilot control lock lever down, the "▲" lamp (yellow) starts flashing.

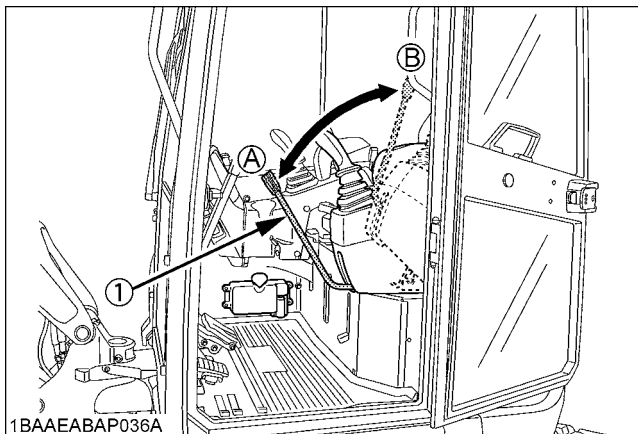

(1) Pilot control lock lever (A) "UNLOCK" (B) "LOCKED"

**IMPORTANT :**

- Always pull pilot control lock lever up to "LOCKED" position (B) when you stop the engine or leave the operating structure.

■ **Working Light Switch**

When the starter switch is in position "RUN", the light(s) will be switched on by pressing the switch.

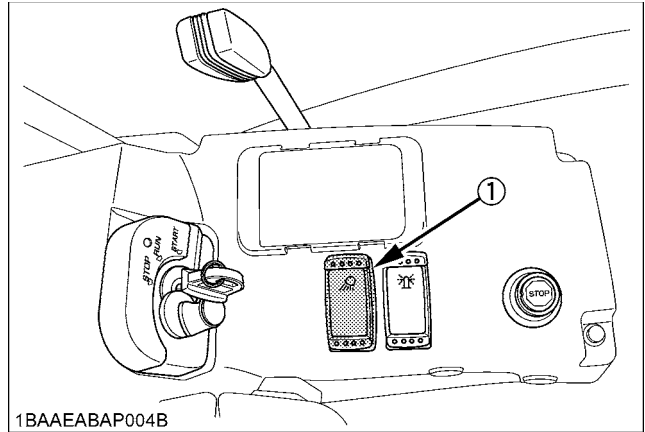

(1) Working light switch

◆ **Night operation**



**WARNING**

To avoid personal injury or death:

- When the working light alone do not provide sufficient visibility, prepare additional stationary artificial lighting and observe safety rules for night work.

■ **Travel Buzzer**

When you handle the drive levers, the buzzer sounds at the same time or before the excavator starts to run.

■ **Beacon Light Switch**

**NOTE :**

- The rotary beacon (accessory) is switched on with this button.

The excavator is equipped only with the switch (including the coupler for connecting in a rear left speaker).

Beacon is not standard equipment, therefore please install when required.

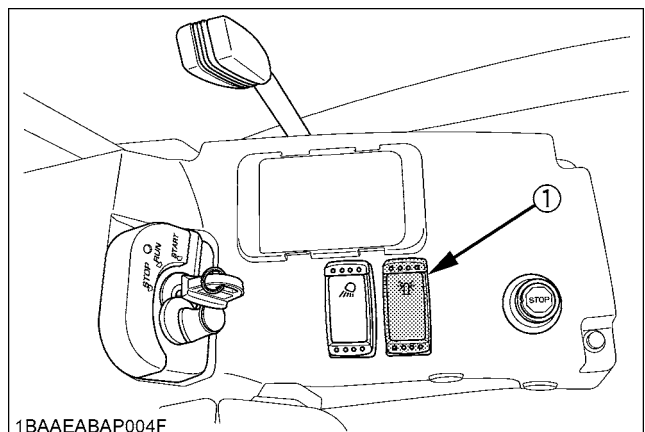

(1) Beacon light switch

## TWO PATTERN SELECTION SYSTEM (TPSS)



### WARNING

To avoid personal injury or death:

- Study control lever pattern A and pattern B. Then choose the one which is most familiar.
- Position the pattern selector lever (located on the right side of operator's seat) in either the backward position (Pattern A) or the forward position (Pattern B).
- Engage the lever lock to prevent accidental pattern change.
- Familiarize yourself with the pattern selected by operating slowly.

### ■ Pattern Change

Moving the pattern selector lever backward until the red knob is locked in position, will activate pattern A.

Moving the pattern selector lever forward until the red knob is locked in position, will activate pattern B.

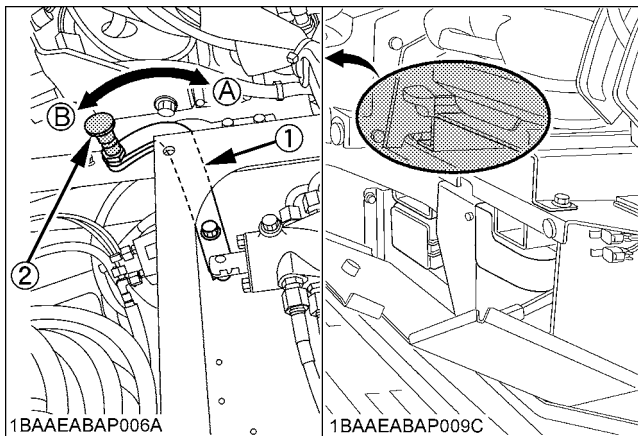

- (1) Pattern selector lever (A) "Pattern A"  
 (Two Pattern Selection System: TPSS) (B) "Pattern B"  
 (2) Red knob

### IMPORTANT :

- The lever and red knob will be locked automatically when the new pattern position is reached.
- Do not operate the excavator unless the lever and red knob have been locked into a pattern position.

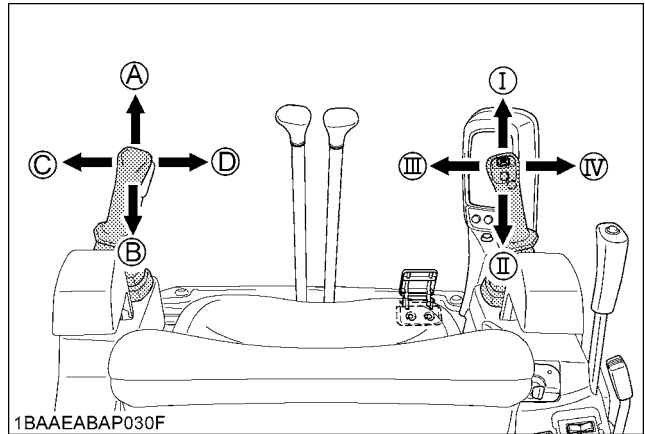

| Lever Position | Attachment Control Lever |                |     |                |
|----------------|--------------------------|----------------|-----|----------------|
|                | (Left)                   | (Right)        |     |                |
| Pattern A      | A                        | Boom down      | I   | Arm out (up)   |
|                | B                        | Boom up        | II  | Arm in (crowd) |
|                | C                        | Swing left     | III | Bucket crowd   |
|                | D                        | Swing right    | IV  | Bucket dump    |
| Pattern B      | A                        | Arm out (up)   | I   | Boom down      |
|                | B                        | Arm in (crowd) | II  | Boom up        |
|                | C                        | Swing left     | III | Bucket crowd   |
|                | D                        | Swing right    | IV  | Bucket dump    |

### OPERATION OF THE BOOM

To raise the boom, pull the attachment control lever back. The boom is equipped with a cushion cylinder which helps prevent excavated material in the bucket from falling out. At low hydraulic oil temperature, (e.g. after starting the engine in cold weather) the cushioning function will be effected for a short period of time (approx. 3 to 5 seconds). This condition results from the viscosity of the hydraulic oil and is not a sign of malfunction. The cushion cylinder will operate normally as the oil warms up. To lower the boom, push the attachment control lever forward.

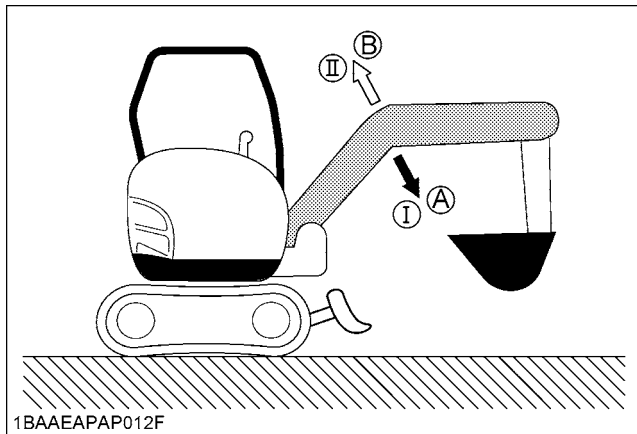
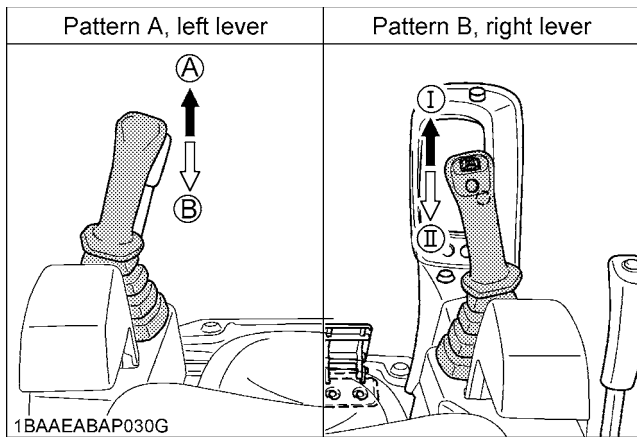

(A) (I) Boom down  
(B) (II) Boom up

### OPERATION OF THE ARM

Pull back the attachment control lever and the arm will be pulled in. To move the arm out, push the control lever towards the front.

**NOTE :**

- When pulling in the arm, the movement may stop for a short moment when the arm is in its vertical position. This is caused by the combined load of the arm and bucket moving the cylinder piston away from the hydraulic flow causing a delay in the cylinder action, until the flow catches up with cylinder piston. This is a characteristic of the hydraulic system and is not a sign of malfunction.

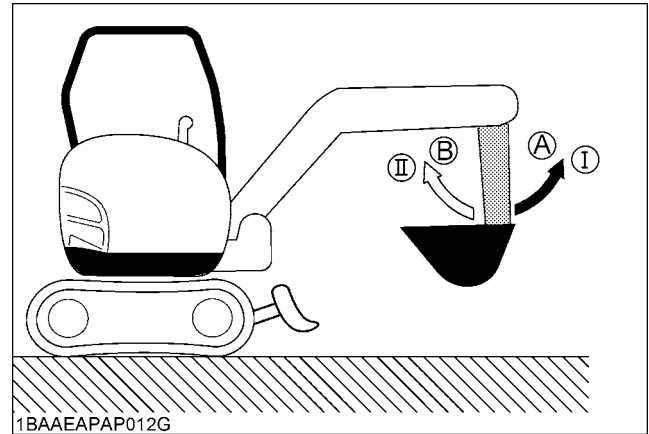
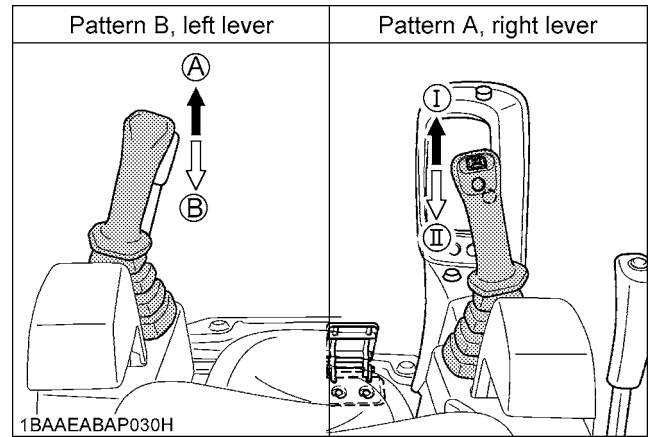

(A) (I) Arm out (up)  
(B) (II) Arm in (crowd)

**IMPORTANT :**

- When lowering the boom, make sure that it does not hit the dozer and that the bucket teeth do not touch the dozer.

## OPERATION OF THE BUCKET

To dig using the bucket, move the right attachment control lever from the neutral position, left. Moving the control lever right, moves the bucket outwards and dumps its contents.

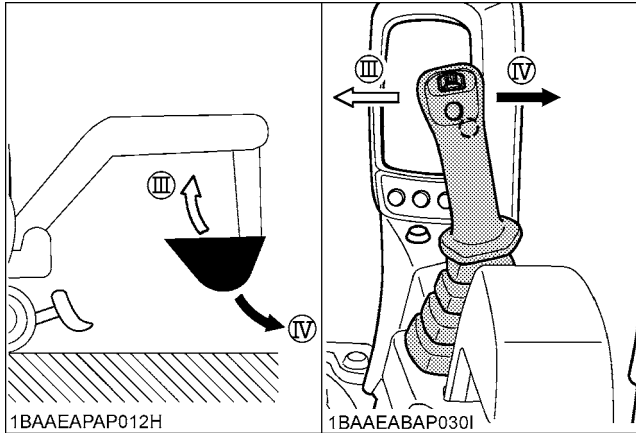

(III) Bucket crowd  
(IV) Bucket dump

## SWIVEL (UNIT SWING) OPERATION



### WARNING

To avoid personal injury or death:

- When working in groups, always let the others know what you are going to do before you do it.
- Keep others away from the machine working area.

### IMPORTANT :

- Do not operate the left attachment control lever abruptly from right to left (or vice versa). Because of the low of inertia, this causes an impact load on the swing gear and the swing motor. Additionally, the life of the excavator will be shortened.
1. Move the control lever to the left and the upper structure will turn to the left.
  2. Move the control lever to the right and the upper structure will turn to the right.

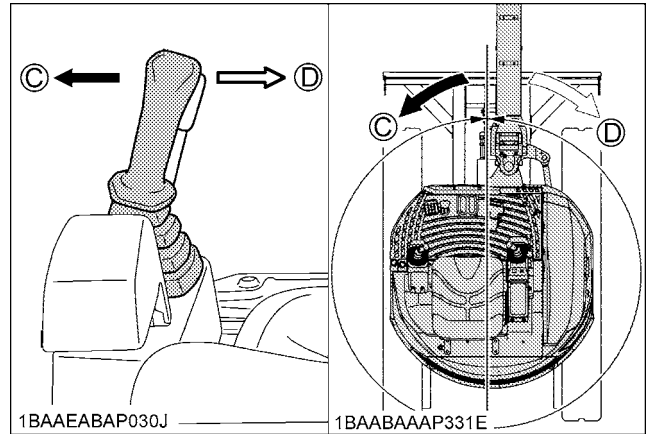

(C) Swing left  
(D) Swing right

## BOOM SWING OPERATION

1. Flip the pedal lock up to unlock the pedal.
2. Step on the left side of the pedal (→) to swing the boom to the left.
3. Step on the right side of the pedal (⇨) to swing the boom to the right.

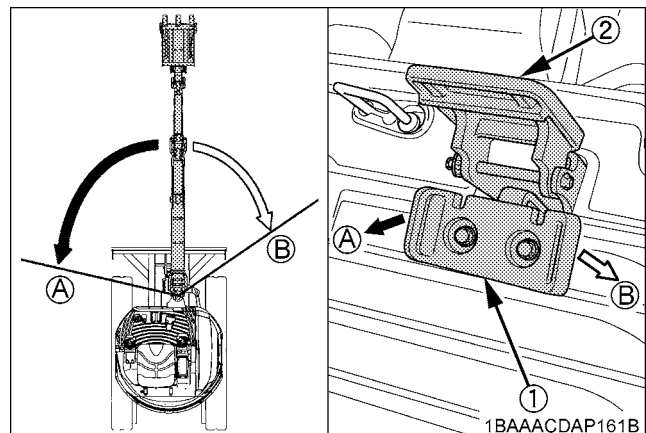

(1) Boom swing pedal  
(2) Pedal lock

(A) Swing left  
(B) Swing right

## OPERATION OF THE DOZER

1. To raise the dozer, pull back the control lever. Pushing the control lever forwards lowers the dozer.

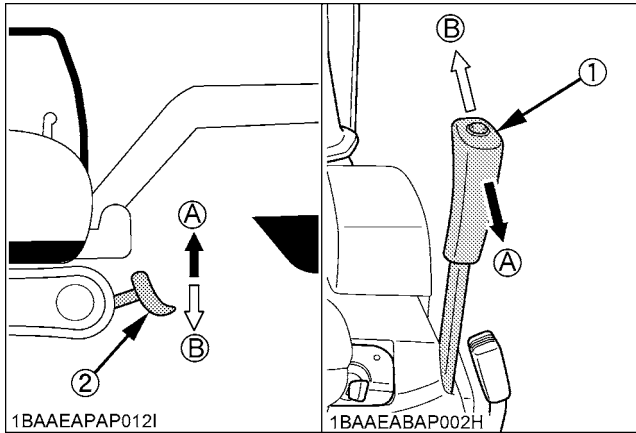

- |                         |             |
|-------------------------|-------------|
| (1) Dozer control lever | (A) "Raise" |
| (2) Dozer               | (B) "Lower" |

2. While undertaking earth moving work, control both drive levers with left hand and the dozer control lever with right hand.

## AUX PORT OPERATION

The excavator is equipped with a hydraulic auxiliary ports. The auxiliary port function is controlled with the rocker switch for auxiliary port.

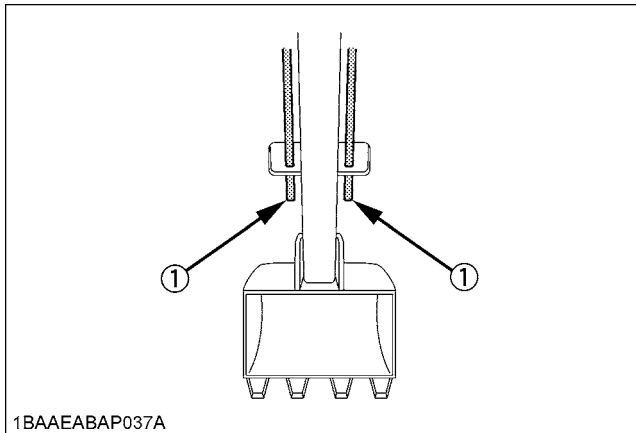

1BAAEABAP037A

- (1) Auxiliary port

### ◆ Operating auxiliary port 1



## WARNING

To avoid personal injury or death:

- Check not only indicator for auxiliary port but also function before you start to operate the machine.

### IMPORTANT :

- The proportional control enables you to smoothly control the implement speed. Example: If you press the rocker switch halfway to the left, the implement moves at approximately half speed.

1. Turn the starter key to the "RUN" position. Let the engine warm up after start-up for approx. 10 minutes under no load conditions.

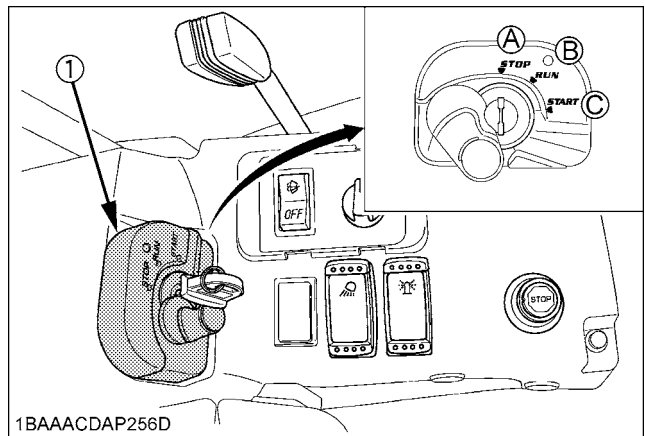

1BAAACDAP256D

- |                    |             |
|--------------------|-------------|
| (1) Starter switch | (A) "STOP"  |
|                    | (B) "RUN"   |
|                    | (C) "START" |

2. Lower the pilot control lock lever (UNLOCK).

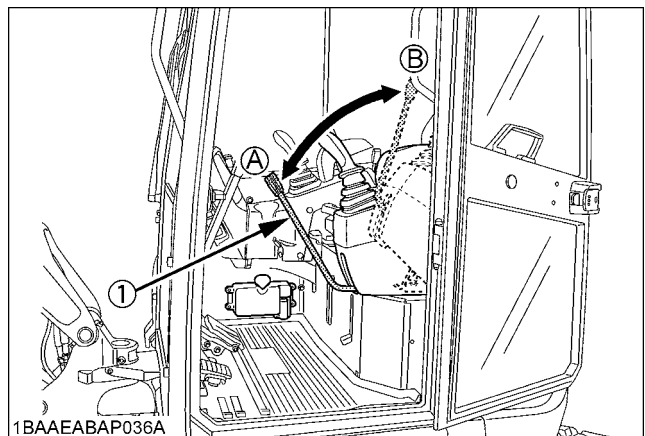

1BAAEABAP036A

- |                              |              |
|------------------------------|--------------|
| (1) Pilot control lock lever | (A) "UNLOCK" |
|                              | (B) "LOCKED" |



3. Push the enable switch for auxiliary port (switch 1).  
Check the indicator for auxiliary port lights up.

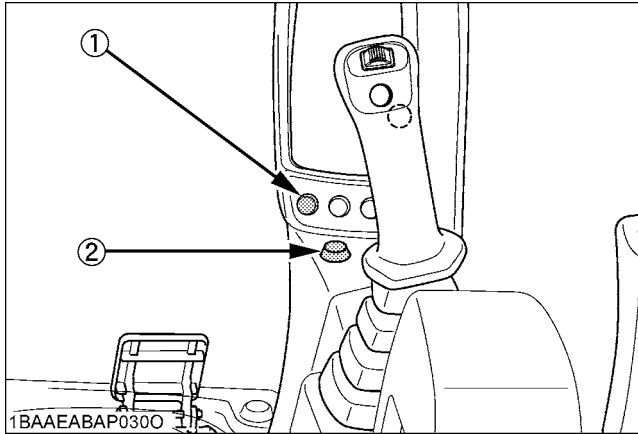

- (1) Enable switch for auxiliary port (switch 1)
- (2) Indicator for auxiliary port

4. Press rocker switch for auxiliary port in the direction right (A), then the oil flows to the right connector (A) of the arm.  
Press rocker switch for auxiliary port in the direction left (B), then the oil flows to the left connector (B) of the arm.

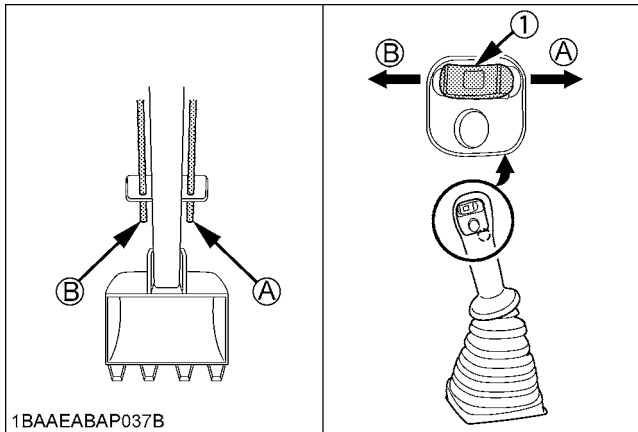

(1) Rocker switch for auxiliary port

- (A) Port A
- (B) Port B

### ■ One-way Hold Switch

Operating the one way hold switch results in a continuous oil flow to the auxiliary port connector to the left of the arm. When you operate it again, the oil flow discontinues. Thus, you can operate, for example, an attachment without having to continuously hold down the button.

Before operating the one way hold switch press the rocker switch for auxiliary port to left and keep the position.

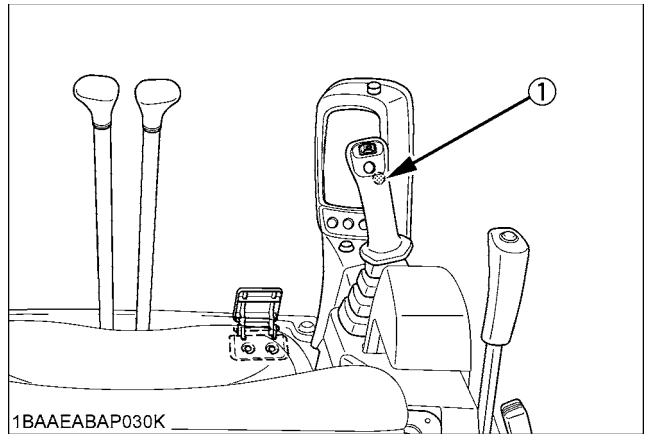

(1) One way hold switch

#### NOTE :

- One way hold operation needs an 1-way circuit to reduce the back pressure (see page 33).

|  |                   |
|--|-------------------|
| Max. Flow Volume<br>Theoretical L/min. (US gal/min.) | 48.0 (12.8)       |
| Max. Pressure<br>MPa (kgf/cm <sup>2</sup> ) [psi]    | 21.6 (220) [3133] |

#### IMPORTANT :

- When the AUX port is not used for a long period, dirt particles can settle in the lower part of the AUX port lines.

When the plugs on the AUX port lines are removed to connect attachments, drain approx. 100 cc (3.4 oz) of oil per side.

For breaker choices, contact your dealer.

# DRIVING

## WARNING

To avoid personal injury or death:

- Before starting the engine, make sure that no one is near the excavator.
- Before operating the excavator, check the track direction. (Idler and dozer to the front of the excavator).

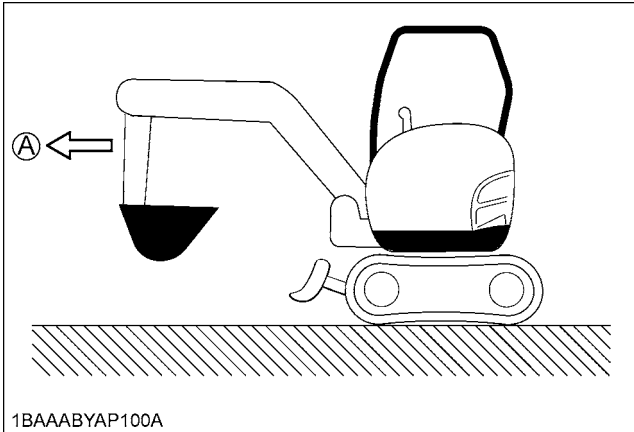

(A) "Front"

- Use extra caution when traveling across a slope or working sideways on a slope.

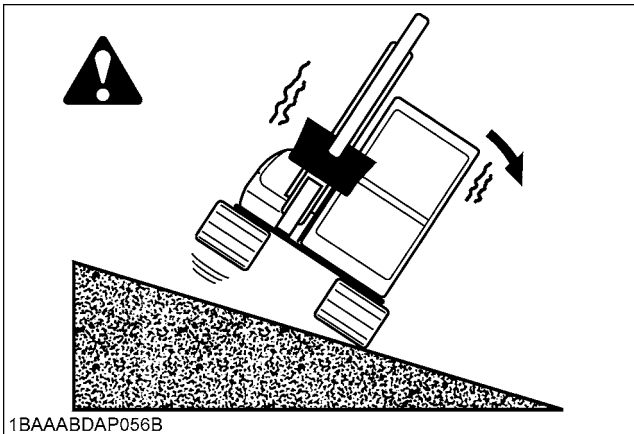

- Recommended technique for working on a slope.

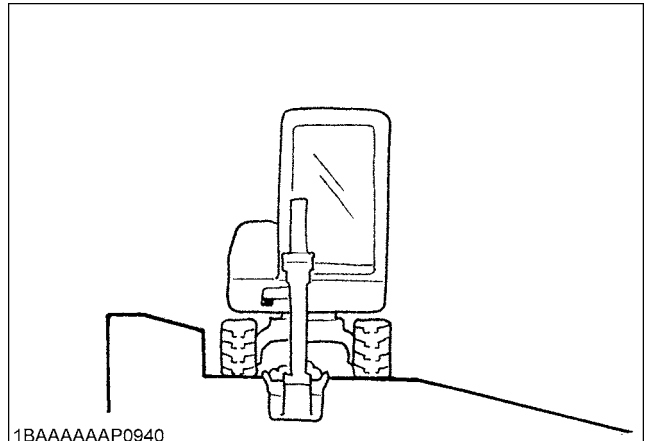

1. Adjust the engine speed from idling to an intermediate speed.
2. Unlock the pilot control lock lever.
3. Raise the dozer and hold the bucket about 20 to 40 cm (8 to 16 in.) over the ground.

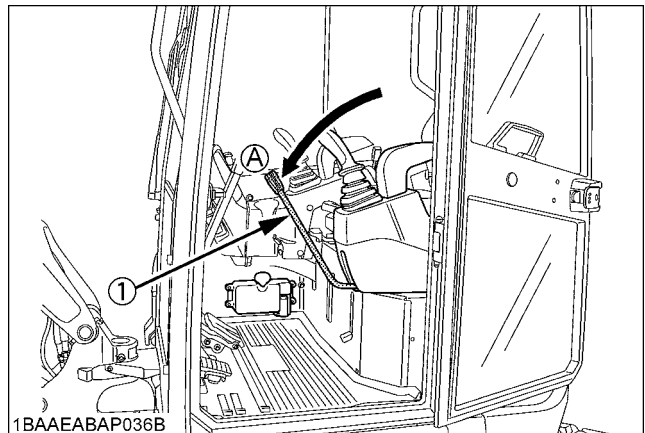

(1) Pilot control lock lever

(A) "UNLOCK"

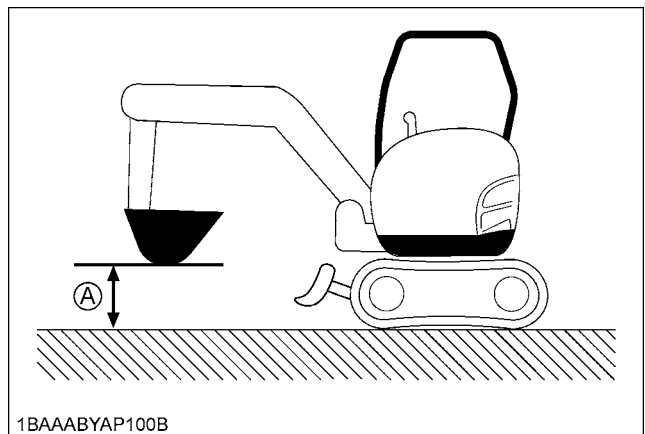

(A) 20 to 40 cm (8 to 16 in.)

■ Drive Levers (Right, Left)

**WARNING**

To avoid personal injury or death:

- If the swing frame has been turned 180°, i.e. the dozer blade is, seen from the operator, "behind", then the travel direction is opposite to the drive direction of the levers (when activating the drive lever forwards, the excavator, seen from the operator, will move backwards).

Pushing the drive lever forward, moves the excavator forward, and vice-versa. The front of the excavator is the direction where the dozer is present.

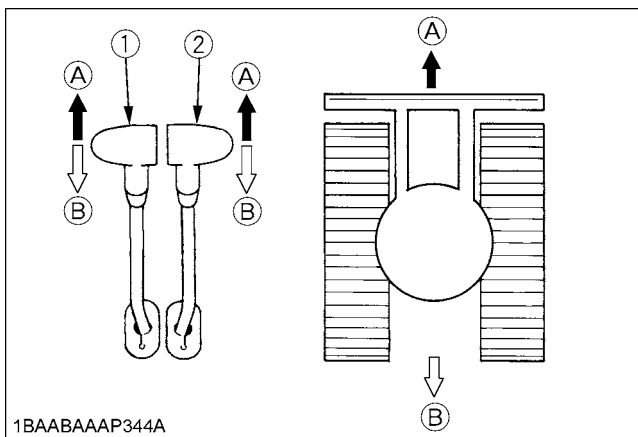

1BAABAAAP344A

- (1) Drive lever (left)
- (2) Drive lever (right)
- (A) "Forward"
- (B) "Backward"

**IMPORTANT :**

- If the tracks are clogged with sand or gravel while working on soft ground, lift up one track with the help of the boom, arm and bucket and let the track rotate to shake off the sand and gravel.

**WARNING**

To avoid personal injury or death:

- When lifting the machine with an attachment, place a safety block or safety post to prevent the machine from turning over. Keep the pilot control lock lever in the "LOCKED" position.

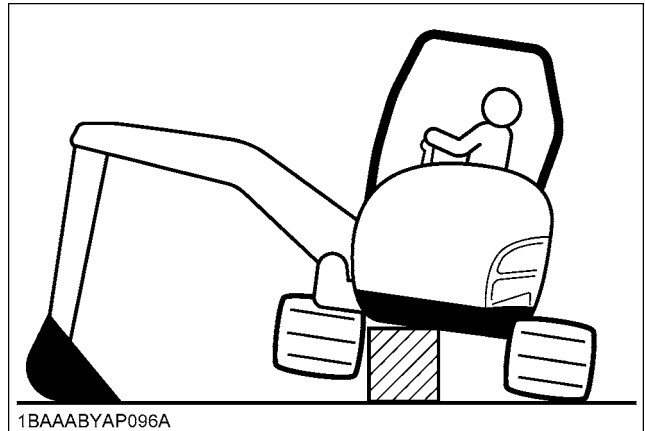

**DANGER**

To avoid serious injury or death:

- Do not work under the machine in this condition.

■ Throttle Lever

At the operator's seat,

1. Move the throttle lever to the "FAST" position, and the engine speed increases.
2. To stop the engine, push the throttle lever fully to the "SLOW" position and turn the starter switch to the "STOP" position.

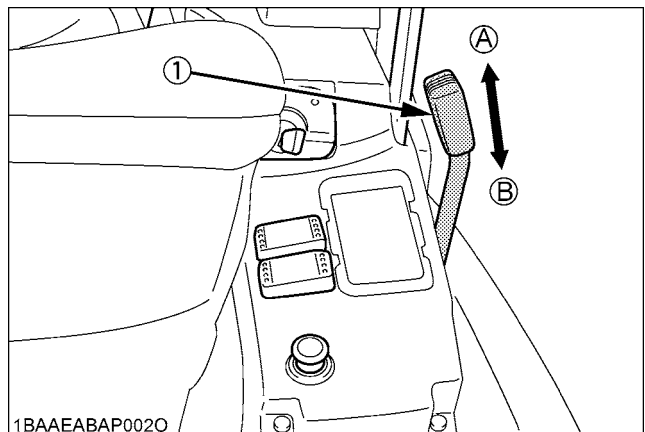



1BAAEABAP002O

- (1) Throttle lever
- (A) "FAST"
- (B) "SLOW"

### ■ Travel Speed Switch

Travel speed will increase when this switch is pushed down.

Switching the dual travel speed:

1. Press the travel speed switch. The buzzer beeps and the travel speed changes from first speed to second. The  symbol lights up.
2. Press the travel speed switch again, and the buzzer beeps and the travel speed changes from second speed to first. The  symbol light goes out.

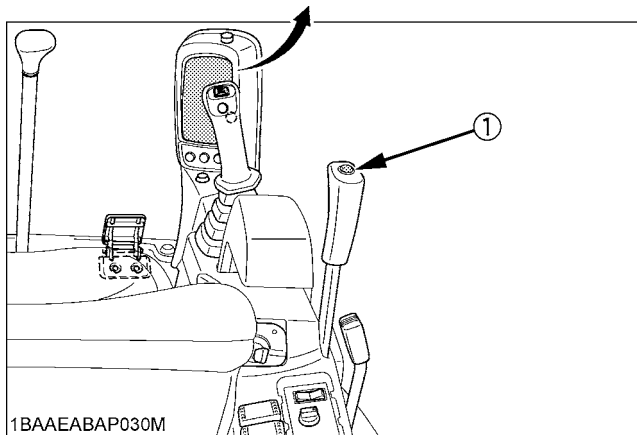
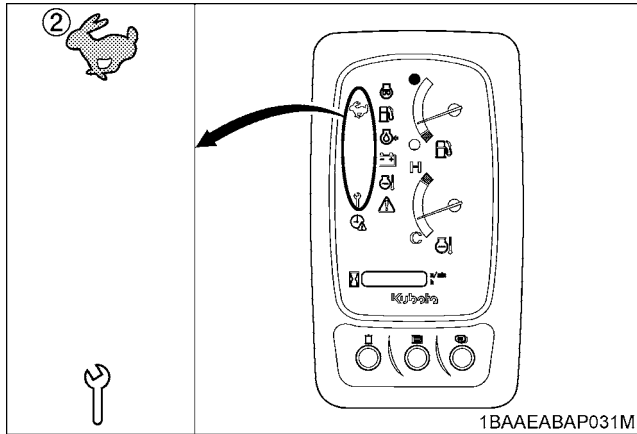

- (1) Travel speed switch  
 (2) Speed indicator lamp

**NOTE :**

- When activating the travel speed switch, it must be pushed down completely.
- Each time the travel speed switch is pressed, the travel speed is switched between first and second.

**IMPORTANT :**

- Do not activate the travel speed switch when there is increased drive resistance (e.g. driving on inclines or on uneven grounds).
- If the tracks are clogged with sand or gravel while working on soft ground, lift up one track with the help of the boom, arm and bucket and let the track rotate to remove the sand and gravel.
- The U27-4 HI model is equipped with an automatic switching mechanism controlled by the torque, which automatically shifts the drive engines from travel speed into the more comfortable low speed when driving at lower speeds with a heavy load or when turning, for example. However, for safety reasons, shifting back up into travel speed must always be done manually using the travel speed switch.

### TURNS

 **WARNING**

To avoid personal injury or death:

- Do not change direction on steep slopes, or the excavator could tip over.
- Before changing direction, beware of people in the work area.

### ■ Pivot Turn

**NOTE :**

- Movement as illustrated shows the turning directions with the dozer blade in the front.

### ◆ Change of Direction while Stationary

1. Push the left drive lever forward; the excavator will turn in the direction of the arrow of the illustration below.

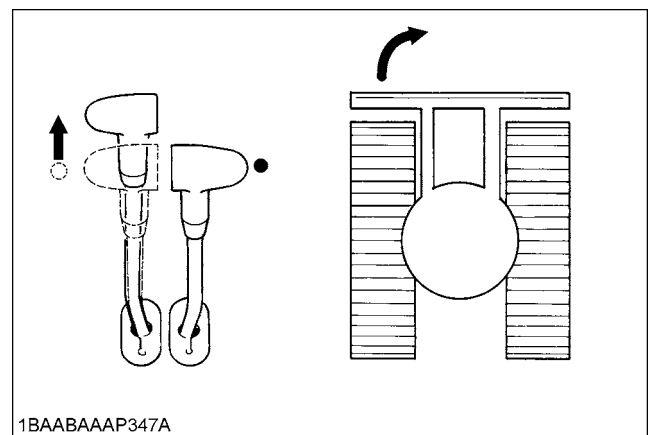

2. Pull the left drive lever backward; the excavator will turn in the direction of the arrow of the illustration below.

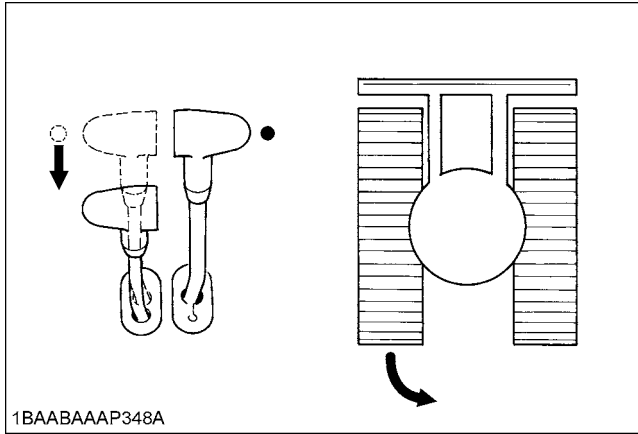

**◆ Change of Direction while Travelling**

1. While travelling forwards, bring the left drive lever in the neutral position; the excavator will turn in the direction of the arrow of the illustration below.

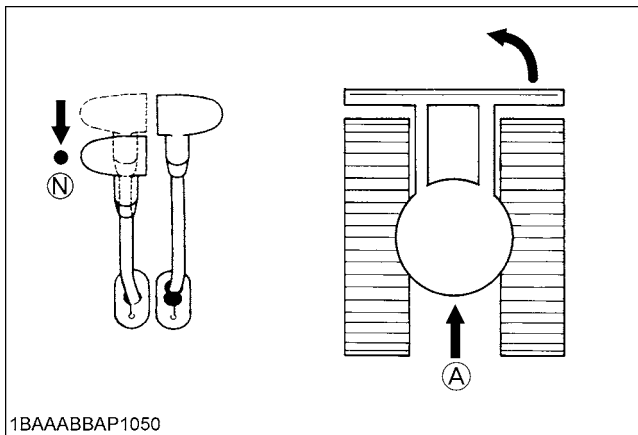

(A) "Travelling forward"  
(N) "Neutral position"

2. While travelling backwards, bring the left drive lever in the neutral position; the excavator will turn in the direction of the arrow of the illustration below.

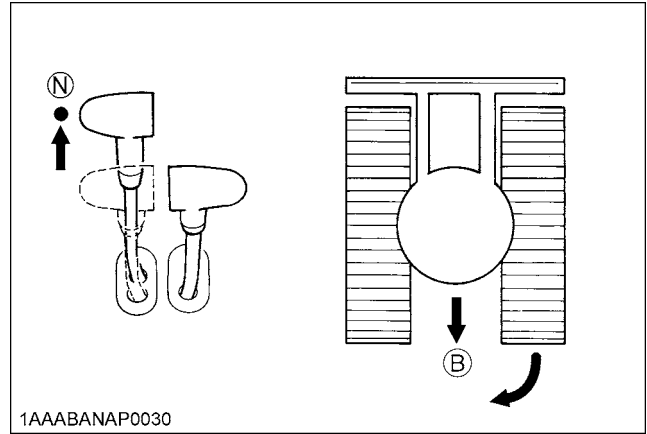

(B) "Travelling backward"  
(N) "Neutral position"

**■ Spin Turn**

When both drive levers are activated in the opposite directions, both track will rotate with the same speed but in opposite directions. The center of rotation is the center of the excavator.

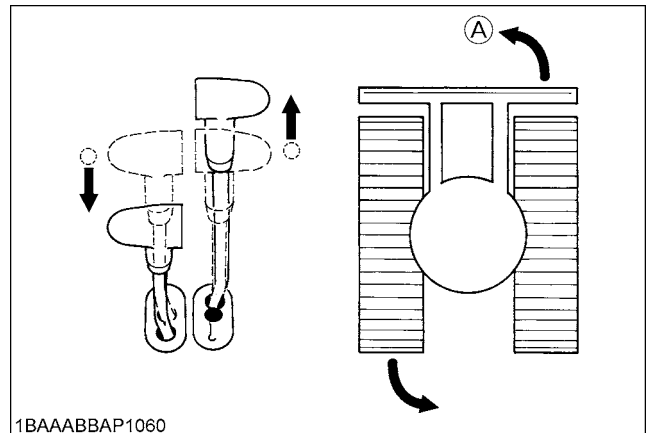

(A) "Left spin turn"

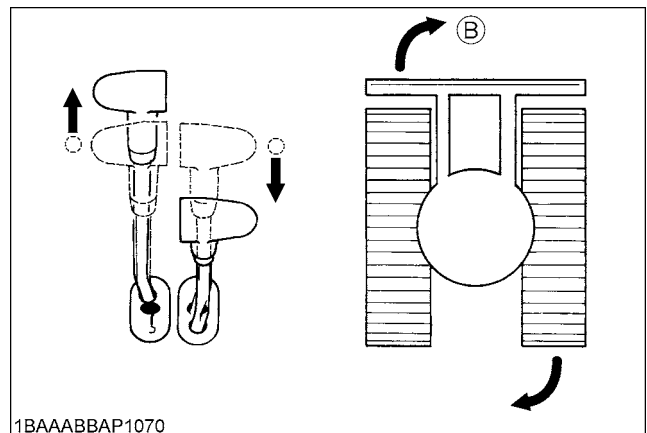

(B) "Right spin turn"

## UP AND DOWNHILL TRAVELLING



### WARNING

To avoid personal injury or death:

- When travelling up or down a slope, use extra caution and follow the instructions below.

While travelling uphill, keep the lower edge of the bucket approx. 20 to 40 cm (8 to 16 in.) above the ground. Although the KUBOTA excavator will not slip easily because of the crawlers, it is safer to let the bucket slide over the ground while travelling downhill.

Always choose slow speed for uphill and downhill travelling.

### [UPHILL TRAVELLING]

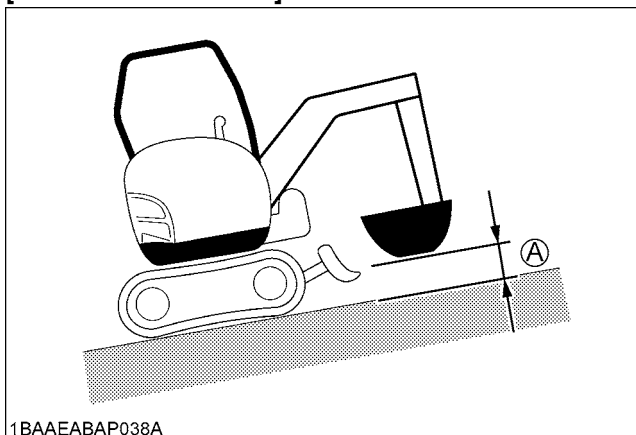

1BAAEABAP038A

(A) 20 to 40 cm (8 to 16 in.)

### [DOWNHILL TRAVELLING]

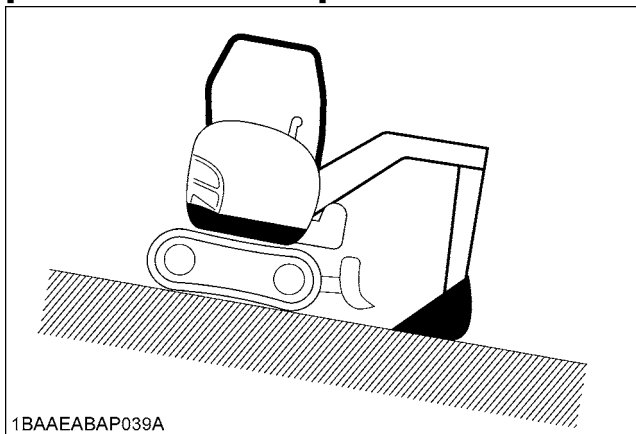

1BAAEABAP039A

## PARKING ON A SLOPE



### WARNING

To avoid personal injury or death:

- When the excavator is parked or left unattended on a slope, be sure to put the tip of the bucket into the ground and place all control levers in neutral position, then brace the tracks with chocks.

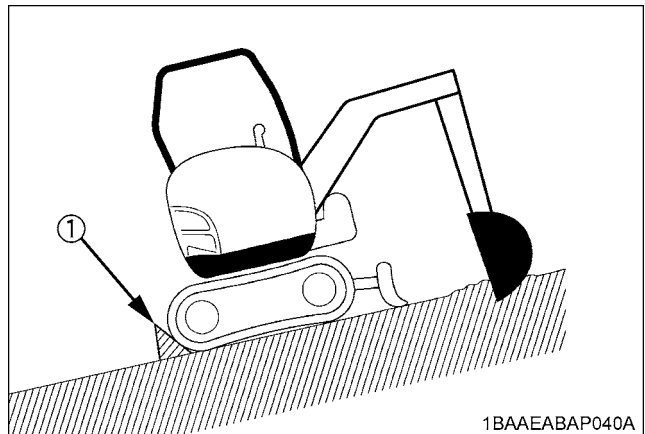

1BAAEABAP040A

(1) Chock

## PARKING



### WARNING

To avoid personal injury or death:

- Do not keep the bucket or dozer in an elevated position, as a person could accidentally touch the levers and cause serious accidents.

1. Park the machine on hard flat ground. Stand the arm vertically and lower the bucket to the ground.
2. Turn the throttle potentiometer fully to low speed and idle the engine for about 5 minutes to cool it off gradually.
3. Turn the starter switch to "STOP", stop the engine, then remove the key.
4. Pull the pilot control lock lever up to the "LOCKED" position.
5. When leaving the machine, close all covers and lock.

## 1-way or 2-way CIRCUIT SELECTION VALVE OPERATION

A selection valve which selects 1-way or 2-way circuit of AUX port has been installed on the hydraulic tank.

1. When equipment which needs a 1-way circuit will be used, position the arrow, by using the selector lever, on the axis of the selection valve to the 1-way circuit position, to reduce the back pressure.
2. When equipment which needs a 2-way circuit will be used, position the arrow on the axis of the selection valve to the 2-way circuit position.

### NOTE :

- 1-way circuit..... HAMMER etc.
- 2-way circuit..... THUMB, TILT BUCKET, AUGER, GRAPPLE etc.

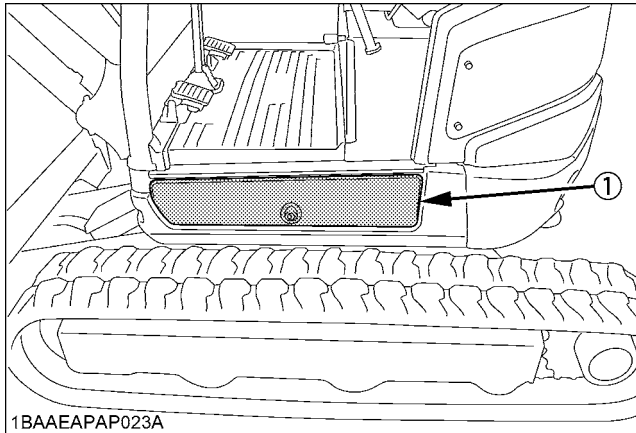

(1) Swivel frame cover

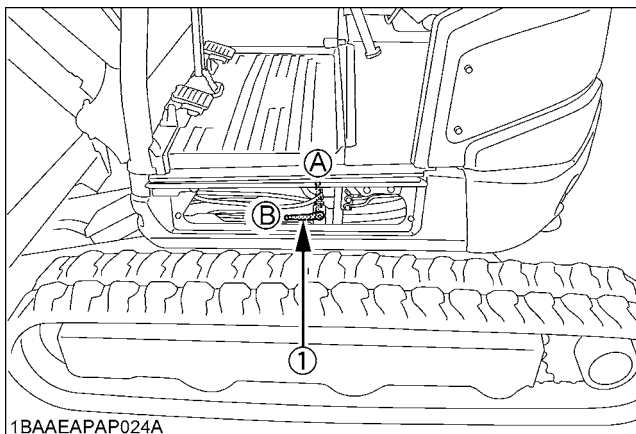

(1) Selector lever

(A) "1 way"

(B) "2 way"



## WARNING

To avoid personal injury or death:

- Stop the engine before removing/changing the equipment.
- Release pressure in the hydraulic system before removing/changing the equipment. (See "HOW TO RELEASE PRESSURE TRAPPED IN THE HYDRAULIC SYSTEM".)
- Position the selection valve to the correct position (either 1-way or 2-way circuit selection) before mounting the equipment.
- Always select the correct valve position before mounting the equipment (1-way or 2-way circuit selection) to avoid sudden movement of the equipment.

### NOTE :

- Leaving the selection valve to 1-way circuit selection and attaching 2-way circuit equipment may cause the equipment to move (drop) suddenly due to its own weight, as the tank line remains open, even with the engine off.

## IMPORTANT INFORMATION ON EXCAVATOR OPERATION

- Do not try to crush concrete or boulders using side swings with the bucket. Also avoid using side sweeps of the bucket to move earth piles.
- Under all circumstances avoid the following operations:
  - Excavation using the gravitational impact of the machine.
  - Compacting of gravel or soil using the dropping action of the bucket.
  - Excavation using the traveling power of the machine.
- Do not try to drop or shake off soil adhering to the bucket in the manner given in the points below. This can cause damage to the machine.

Adhering soil can be shaken off when the bucket is being emptied by moving the bucket out to the maximum stroke of the cylinder. Should this not suffice, swing out the arm as far as possible and operate the bucket back and forth.

- Do not hit the dozer with the boom cylinder!  
Make sure that the boom cylinder does not hit the dozer when doing deep excavation. If necessary swing around so that the dozer is in the back of the machine.
- Pay attention when pulling in the bucket!  
When pulling in the bucket (for driving or transportation) avoid hitting the dozer.
- Avoid collisions!  
When moving the excavator, pay attention that the dozer does not collide with obstructions such as boulders, etc.

Such collisions shorten the life of the dozer and the cylinder substantially.

- Support the machine correctly!  
When stabilizing the machine with the dozer, lower the dozer to engage the full width on the ground.
- If the water or mud level reaches higher than the top of the tracks, the swivel bearing, swivel motor gear and ring gear may be exposed to mud, water and other foreign objects.

The excavator must be properly pressure washed after each use.

- Thoroughly clean the area around the swivel bearing, swivel motor gear and ring gear to remove foreign objects.
- Inspect the swivel motor oil sump (if equipped) for water contamination. If water is present, refer to operator's manual for lubricant replacement procedure.
- Refer to operator's manual for proper swivel bearing, swivel motor gear and ring gear lubrication procedures.
- Reinstall any protective covering if removed earlier.

## HOW TO RELEASE PRESSURE TRAPPED IN THE HYDRAULIC SYSTEM

1. Lower the attachments and the dozer blade to the ground.
2. Turn the key to "STOP" position and shut off the engine.
3. Wait until the engine has come to a standstill.
4. Turn the key to "RUN" position.

### IMPORTANT :

- Do not start the engine.
5. Set the pilot control lock lever to "UNLOCK" position.
  6. Move control levers for front attachment (left and right) several times to limit stop in all directions.
  7. Set the potentiometer to the maximum flow rate.

Then the hydraulic system has been depressurised.

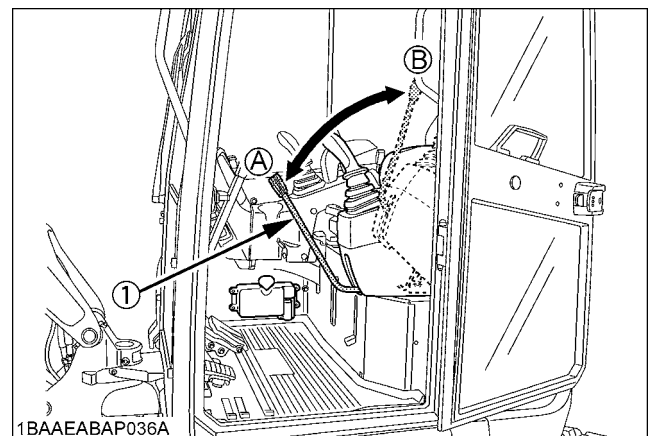

(1) Pilot control lock lever (A) "UNLOCK" (B) "LOCKED"

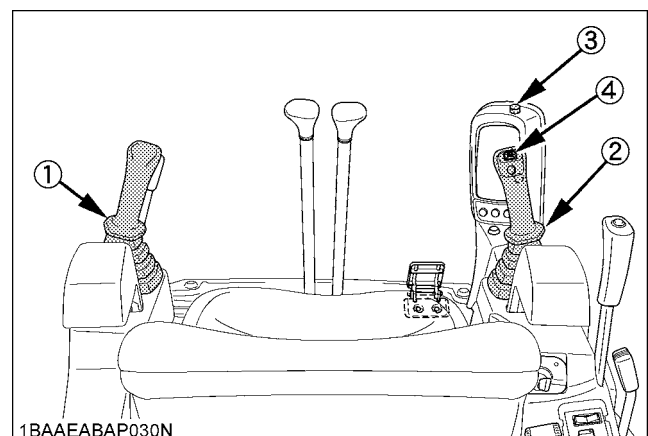

(1) Control lever for front attachment (Left)  
(2) Control lever for front attachment (Right)  
(3) Potentiometer for auxiliary port  
(4) Rocker switch for auxiliary port



# TRANSPORTING THE EXCAVATOR ON A TRUCK



## DANGER

To avoid serious injury or death:

- No directional changes should be made when the excavator is on the ramp. Should a change of direction be necessary, drive off the ramp completely and make the turn.
- When driving forwards or backwards onto the truck, or when swinging the upper body, make sure that neither the cabin or the gates of the truck will be damaged.

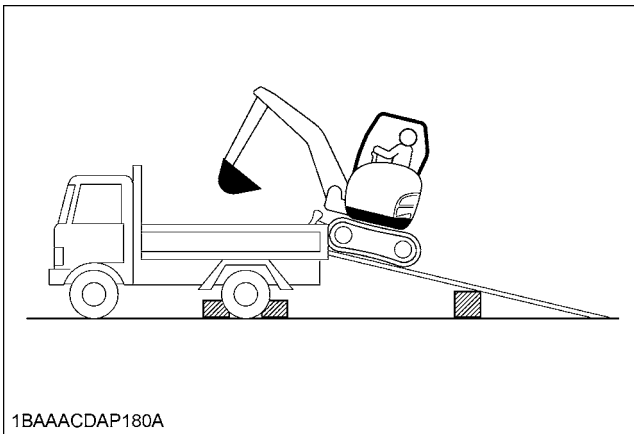

- When the excavator reaches the point between the ramps and the truck bed, halt and then move very slowly until the excavator reaches the horizontal position.
- Move the excavator onto the truck only with the arm completely pulled in. Otherwise the truck cabin could be damaged when swinging around the upper body.
- Do not jack up the machine using its boom to load or unload the excavator from the truck. Dangerous situation could arise.

## ■ Transporting on a Truck



## WARNING

To avoid personal injury or death:

- After loading the machine on the truck, lower the bucket and dozer onto the truck bed.

Prepare a platform to load or unload the excavator. Take following steps when using ramps.

1. Apply the parking brakes of the truck, and block the drive wheels from both sides.

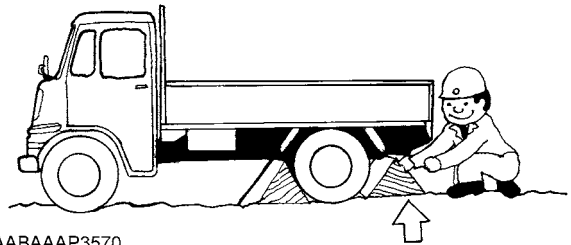

2. Use mounting brackets to secure the ramp properly. Connect the ramps directly to the truck bed.

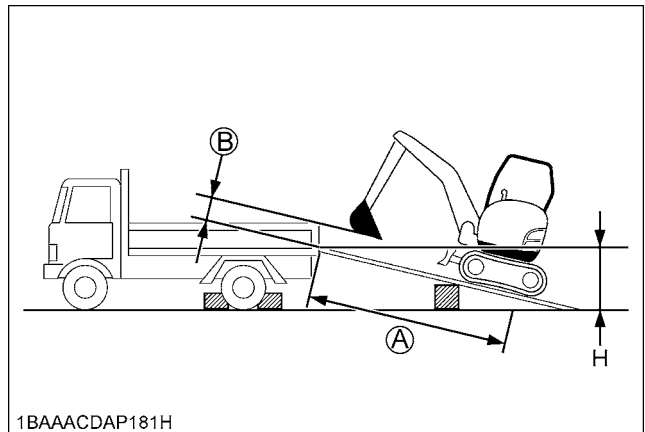

(A) 4 x H or more  
(B) 20 to 40 cm (8 to 16 in.)

3. For additional safety, use blocks or supports under the ramps and the truck bed.
4. Align the ramps and the tracks and then drive the excavator slowly up the ramps with the dozer in the front. After ensuring that the tracks are completely on the truck bed, swivel the upper body around to the back of the truck.

5. Block the tracks and tie down the excavator with suitable chains and approved method (check appropriate state regulation).

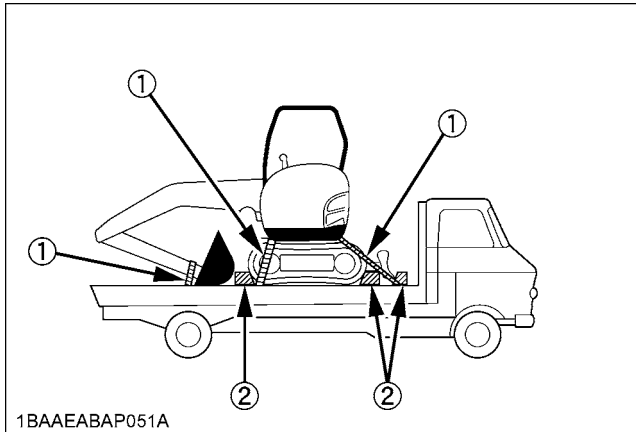

- (1) Chain
- (2) Block

6. Before unloading, raise the dozer and bucket from the truck bed.

### ■ Towing the machine



### WARNING

To avoid personal injury or death:

- When towing the excavator or pulling a load must be less than the strength of the towing line attached to excavator. Not to be used for tie-down or lifting the machine.
- Towing is only allowed over a short distance and at walking speed.

1. Attach the tow bar or towing rope to the hook on the excavator and to the pulling vehicle. The tow bar should be mounted at a right angle to the vehicles.
2. The operator must be seated during the recovery procedure.
3. Drive slowly with the tractive vehicle to avoid abrupt loads.

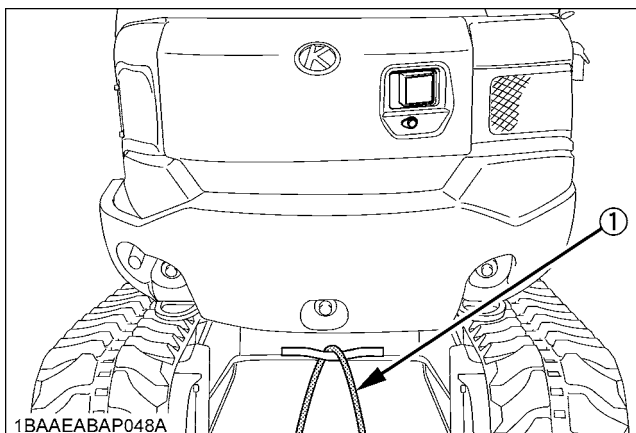

- (1) Tow line

# LIFTING OF THE EXCAVATOR



## DANGER

To avoid serious injury or death:

- The correct instructions for safe handling are described here. Read these instructions carefully before moving the machine. Make sure that the operating personnel read the operator's manual carefully.

## ■ Basics when Lifting with Cables or Straps

1. The lifting and crane operation is to be undertaken according to the guidelines described.
2. The equipment used for lifting mentioned in these instructions are only given as reference, the standards concerning strength, control and other details are based on the respective applicable guidelines.

## ■ Safety Aspects when Lifting with Cables or Straps

Abide by following steps when lifting:

1. Do not lift loads that exceed the maximum load capacity of the crane.
2. Choose correct equipment suitable to the weight, size and form of the load.
3. First assess the center of gravity of the load, position the hook directly over the load and lift the load so that the center of gravity of the load is as low as possible.
4. The steel cables or straps must be fixed in the middle of the hook.
5. The load must be lifted vertically from the ground.
6. Do not enter the working area under suspended loads and do not move the load over people. The load must only be moved in an area where the balance can be easily maintained.

## ■ Lifting Procedure for the Excavator



## WARNING

To avoid personal injury or death.

- Do not use the hooks on the roof of canopy or cabin for lifting the excavator.
- The excavator may only be lifted at the points provided. Do not attach the lifting gear to any other eyes or areas as this can lead to substantial damage.

## ◆ General guidelines for lifting

1. Lifting position. (see illustration)
  - (1) Pull in the boom towards rear.
  - (2) Pull in the arm completely.
  - (3) Pull in the bucket completely.
  - (4) Adjust the swing angle to the center. (to bring the boom in a position parallel to the machine frame)
  - (5) Swing frame so that dozer blade is to the rear and frame is parallel with tracks.
  - (6) Raise the dozer blade fully.

### [Blade ends]

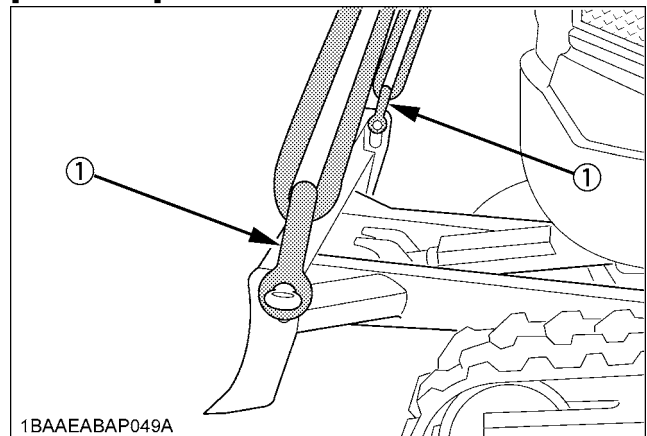

(1) Shackle

### [Boom top]

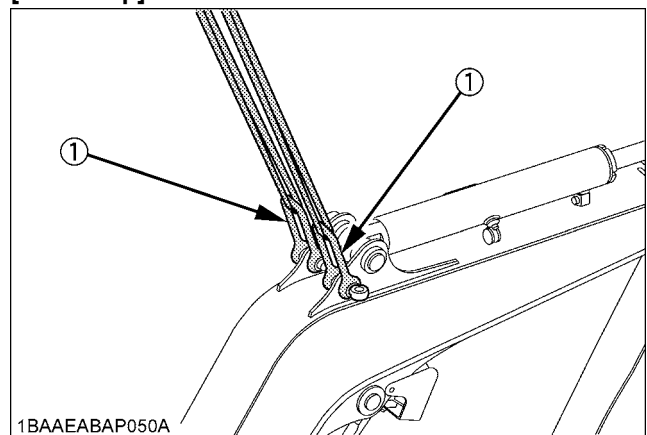

(1) Shackle

2. Attaching the steel cables or straps.
  - (1) Always hook the excavator at three points. (one on the boom and right and left of the dozer)
  - (2) Always use a shackle on each lifting hole when attaching the cables or straps.
  - (3) Use protective material at all places where the cables or straps contact the machine.
  - (4) Keep the angle between the front and rear cables or straps within  $30^\circ$  ( $0.52 \text{ rad.}$ ).

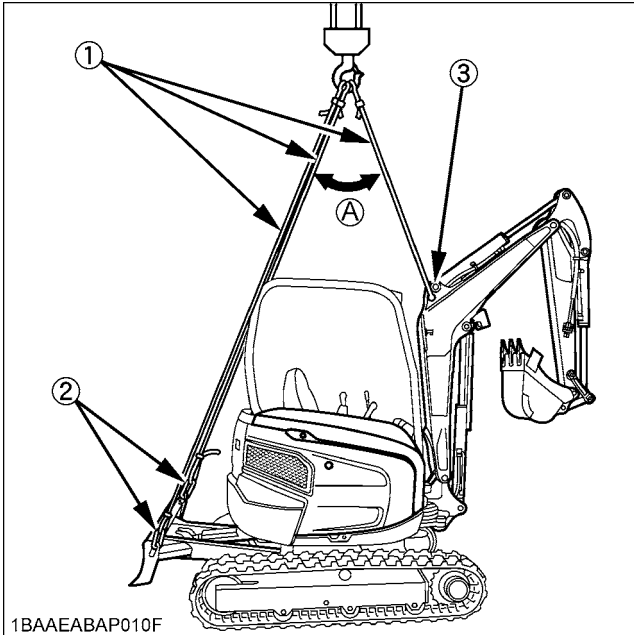

- (1) Steel cable
  - (2) Shackle
  - (3) Protective material
- (A)  $30^\circ$  ( $0.52 \text{ rad.}$ ) or less

3. Tackle
 

The weights of the excavators and the recommended tackle for lifting these loads are mentioned in the following table. Choose components having enough strength.

|  |                               |
|--|-------------------------------|
| Excavator Weight*                        | 2520 kg (5561 lb)             |
| Load / Cable                             | 8500 N (866.7 kgf) [1911 lbf] |
| Minimum Cable Diameter (Safety factor=6) | 12.5 mm (0.49 in.) or more    |

\*Excavator Weight: With canopy, steel tracks.  
Steel cable: 6X24

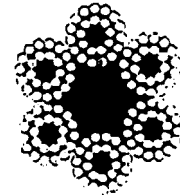

1AAABANAP034A

4. Lifting
  - (1) Lift slowly and safely
  - (2) Do not enter the excavator area when lifting.
  - (3) Lift the excavator horizontally. (Modify cable or strap connections according to needs)

Maximum strength  
for example: (ISO 4344: 2004) - "6X24"

| Diameter      | zinc-plated                          | not zinc-plated                      |
|---------------|--------------------------------------|--------------------------------------|
| 10 mm (3/8)   | 45.8 kN<br>(4670 kgf)<br>[10296 lbf] | 49.3 kN<br>(5027 kgf)<br>[11083 lbf] |
| 12.5 mm (1/2) | 71.5 kN<br>(7290 kgf)<br>[16072 lbf] | 77 kN<br>(7851 kgf)<br>[17308 lbf]   |
| 14 mm (9/16)  | 89.7 kN<br>(9146 kgf)<br>[20163 lbf] | 96.6 kN<br>(9850 kgf)<br>[21716 lbf] |
| 16 mm (5/8)   | 117 kN<br>(11930 kgf)<br>[26301 lbf] | 126 kN<br>(12848 kgf)<br>[28325 lbf] |
| 18 mm (45/64) | 148 kN<br>(15091 kgf)<br>[33270 lbf] | 160 kN<br>(16315 kgf)<br>[35968 lbf] |

# MAINTENANCE

## MAINTENANCE INTERVALS

| No. | Check points                             |               | Measures | Hour meter indicator |     |     |     |     |     |     |     |     |   | Intervals      | Ref. page      |    |    |    |
|-----|--|---------------|----------|----------------------|-----|-----|-----|-----|-----|-----|-----|-----|---|----------------|----------------|----|----|----|
|     |  |               |          | 50                   | 100 | 150 | 200 | 250 | 300 | 350 | 400 | 450 |   |                |                |    |    |    |
| 1   | Coolant                                  |               | check    | Daily check          |     |     |     |     |     |     |     |     |   |                | 43             |    |    |    |
|     |  |               | change   |                      |     |     |     |     |     |     |     |     |   |                | every 2 years  | 60 |    |    |
| 2   | Fuel                                     |               | check    | Daily check          |     |     |     |     |     |     |     |     |   |                | 44             |    |    |    |
| 3   | Engine oil                               |               | check    | Daily check          |     |     |     |     |     |     |     |     |   |                | 44             |    |    |    |
|     |  |               | change   |                      |     |     |     |     |     |     |     |     |   |                | every 500 hrs  | 54 | *5 |    |
| 4   | Hydraulic oil                            |               | check    | Daily check          |     |     |     |     |     |     |     |     |   |                | 45             |    |    |    |
|     |  |               | change   |                      |     |     |     |     |     |     |     |     |   |                | every 1000 hrs | 58 | *1 |    |
| 5   | Lubrication points                       |               | -        | Daily check          |     |     |     |     |     |     |     |     |   |                | 46             |    |    |    |
| 6   | Fan belt tension                         |               | check    | Daily check          |     |     |     |     |     |     |     |     |   |                | 47             |    |    |    |
|     |  |               | adjust   |                      |     |     | ○   |     |     |     |     |     | ○ |                | every 200 hrs  | 51 |    |    |
| 7   | Radiator and oil cooler                  |               | check    | Daily check          |     |     |     |     |     |     |     |     |   |                | 47             |    |    |    |
| 8   | Engine and electrical wiring             |               | check    | Daily check          |     |     |     |     |     |     |     |     |   |                | 48             |    |    |    |
| 9   | Fuel tank, Fuel filter                   |               | drain    | ○                    | ○   | ○   | ○   | ○   | ○   | ○   | ○   | ○   | ○ | ○              | every 50 hrs   | 49 |    |    |
| 10  | Water separator                          |               | drain    | ○                    | ○   | ○   | ○   | ○   | ○   | ○   | ○   | ○   | ○ | every 50 hrs   | 49             |    |    |    |
| 11  | Battery condition                        |               | check    | ○                    | ○   | ○   | ○   | ○   | ○   | ○   | ○   | ○   | ○ | every 50 hrs   | 50             |    |    |    |
| 12  | Greasing swing bearing teeth             |               | -        | ○                    | ○   | ○   | ○   | ○   | ○   | ○   | ○   | ○   | ○ | every 50 hrs   | 51             |    |    |    |
| 13  | Radiator hoses and clamps                |               | check    |                      |     |     | ○   |     |     |     |     | ○   |   | every 200 hrs  | 52             |    |    |    |
|     |  |               | replace  |                      |     |     |     |     |     |     |     |     |   |                | every 2 years  | 60 |    |    |
| 14  | Air filter element                       | Outer element | clean    |                      |     |     | ○   |     |     |     |     | ○   |   | every 200 hrs  | 52             | *2 | @  |    |
|     |  | Inner element | replace  |                      |     |     |     |     |     |     |     |     |   | every 1000 hrs | 59             | *2 |    |    |
|     |  |               | replace  |                      |     |     |     |     |     |     |     |     |   |                | every 1000 hrs | 59 |    | *2 |
| 15  | Greasing swing ball bearing              |               | -        |                      |     |     | ○   |     |     |     |     | ○   |   | every 200 hrs  | 53             |    |    |    |
| 16  | Fuel line and Intake air line            |               | check    |                      |     |     | ○   |     |     |     |     | ○   |   | every 200 hrs  | 53             |    | @  |    |
|     |  |               | replace  |                      |     |     |     |     |     |     |     |     |   |                | every 2 years  | 61 |    | *3 |
| 17  | Pivot valve                              |               | -        |                      |     |     |     | ○   |     |     |     |     |   | every 250 hrs  | 54             |    |    |    |
| 18  | Engine oil filter                        |               | replace  |                      |     |     |     |     |     |     |     |     |   | every 500 hrs  | 55             | *5 |    |    |
| 19  | Drive unit oil                           |               | change   | ●                    |     |     |     |     |     |     |     |     |   | every 500 hrs  | 56             | *5 |    |    |
| 20  | Fuel filter cartridge                    |               | replace  |                      |     |     |     |     |     |     |     |     |   | every 500 hrs  | 56             | *5 | @  |    |
| 21  | Hydraulic return filter element          |               | replace  |                      |     |     |     |     |     |     |     |     |   | every 500 hrs  | 57             | *5 |    |    |
| 22  | Hydraulic suction filter element         |               | replace  |                      |     |     |     |     |     |     |     |     |   | every 1000 hrs | 58             | *5 |    |    |
| 23  | Fuel injection nozzle injection pressure |               | check    |                      |     |     |     |     |     |     |     |     |   | every 1500 hrs | 59             | *4 | @  |    |
| 24  | Front idler and track roller oil         |               | change   |                      |     |     |     |     |     |     |     |     |   | every 2000 hrs | 59             | *5 |    |    |
| 25  | Alternator and starter motor             |               | check    |                      |     |     |     |     |     |     |     |     |   | every 2000 hrs | 59             |    |    |    |
| 26  | Injection pump                           |               | check    |                      |     |     |     |     |     |     |     |     |   | every 3000 hrs | 60             | *4 | @  |    |
| 27  | Radiator system                          |               | rinse    |                      |     |     |     |     |     |     |     |     |   | every 2 years  | 60             |    |    |    |

\* 500 thru 1000 continued to the following table.

| No. | Check points                             |               | Measures | Hour meter indicator |     |     |     |     |     |     | Intervals | Ref. page      |                |          |      |
|-----|--|---------------|----------|----------------------|-----|-----|-----|-----|-----|-----|-----------|----------------|----------------|----------|------|
|     |  |               |          | 500                  | 550 | 600 | 650 | 700 | 750 | 800 |           |                |                |          | 1000 |
| 1   | Coolant                                  |               | check    | Daily check          |     |     |     |     |     |     |           | 43             |                |          |      |
|     |  |               | change   |                      |     |     |     |     |     |     |           | every 2 years  | 60             |          |      |
| 2   | Fuel                                     |               | check    | Daily check          |     |     |     |     |     |     |           | 44             |                |          |      |
| 3   | Engine oil                               |               | check    | Daily check          |     |     |     |     |     |     |           | 44             |                |          |      |
|     |  |               | change   | ○                    |     |     |     |     |     |     | ○         | every 500 hrs  | 54             | *5       |      |
| 4   | Hydraulic oil                            |               | check    | Daily check          |     |     |     |     |     |     |           | 45             |                |          |      |
|     |  |               | change   |                      |     |     |     |     |     |     | ○         | every 1000 hrs | 58             | *1<br>*5 |      |
| 5   | Lubrication points                       |               | -        | Daily check          |     |     |     |     |     |     |           | 46             |                |          |      |
| 6   | Fan belt tension                         |               | check    | Daily check          |     |     |     |     |     |     |           | 47             |                |          |      |
|     |  |               | adjust   |                      |     | ○   |     |     |     | ○   | ○         | every 200 hrs  | 51             |          |      |
| 7   | Radiator and oil cooler                  |               | check    | Daily check          |     |     |     |     |     |     |           | 47             |                |          |      |
| 8   | Engine and electrical wiring             |               | check    | Daily check          |     |     |     |     |     |     |           | 48             |                |          |      |
| 9   | Fuel tank, Fuel filter                   |               | drain    | ○                    | ○   | ○   | ○   | ○   | ○   | ○   | ○         | every 50 hrs   | 49             |          |      |
| 10  | Water separator                          |               | drain    | ○                    | ○   | ○   | ○   | ○   | ○   | ○   | ○         | every 50 hrs   | 49             |          |      |
| 11  | Battery condition                        |               | check    | ○                    | ○   | ○   | ○   | ○   | ○   | ○   | ○         | every 50 hrs   | 50             |          |      |
| 12  | Greasing swing bearing teeth             |               | -        | ○                    | ○   | ○   | ○   | ○   | ○   | ○   | ○         | every 50 hrs   | 51             |          |      |
| 13  | Radiator hoses and clamps                |               | check    |                      |     | ○   |     |     |     | ○   | ○         | every 200 hrs  | 52             |          |      |
|     |  |               | replace  |                      |     |     |     |     |     |     |           |                | every 2 years  | 60       |      |
| 14  | Air filter element                       | Outer element | clean    |                      |     | ○   |     |     |     | ○   | ○         | every 200 hrs  | 52             | *2       | @    |
|     |  | Inner element | replace  |                      |     |     |     |     |     |     | ○         | every 1000 hrs | 59             | *2       |      |
|     |  |               | replace  |                      |     |     |     |     |     |     |           | ○              | every 1000 hrs | 59       |      |
| 15  | Greasing swing ball bearing              |               | -        |                      |     | ○   |     |     |     | ○   | ○         | every 200 hrs  | 53             |          |      |
| 16  | Fuel line and Intake air line            |               | check    |                      |     | ○   |     |     |     | ○   | ○         | every 200 hrs  | 53             |          | @    |
|     |  |               | replace  |                      |     |     |     |     |     |     |           |                | every 2 years  | 61       | *3   |
| 17  | Pivot valve                              |               | -        | ○                    |     |     |     |     | ○   |     | ○         | every 250 hrs  | 54             |          |      |
| 18  | Engine oil filter                        |               | replace  | ○                    |     |     |     |     |     |     | ○         | every 500 hrs  | 55             | *5       |      |
| 19  | Drive unit oil                           |               | change   | ○                    |     |     |     |     |     |     | ○         | every 500 hrs  | 56             | *5       |      |
| 20  | Fuel filter cartridge                    |               | replace  | ○                    |     |     |     |     |     |     | ○         | every 500 hrs  | 56             | *5       | @    |
| 21  | Hydraulic return filter element          |               | replace  | ○                    |     |     |     |     |     |     | ○         | every 500 hrs  | 57             | *5       |      |
| 22  | Hydraulic suction filter element         |               | replace  |                      |     |     |     |     |     |     | ○         | every 1000 hrs | 58             | *5       |      |
| 23  | Fuel injection nozzle injection pressure |               | check    |                      |     |     |     |     |     |     |           | every 1500 hrs | 59             | *4       | @    |
| 24  | Front idler and track roller oil         |               | change   |                      |     |     |     |     |     |     |           | every 2000 hrs | 59             | *5       |      |
| 25  | Alternator and starter motor             |               | check    |                      |     |     |     |     |     |     |           | every 2000 hrs | 59             |          |      |
| 26  | Injection pump                           |               | check    |                      |     |     |     |     |     |     |           | every 3000 hrs | 60             | *4       | @    |
| 27  | Radiator system                          |               | rinse    |                      |     |     |     |     |     |     |           | every 2 years  | 60             |          |      |

**IMPORTANT :**

● First operation

\*1 When using a hydraulic breaker, change hydraulic oil and return filter according to the table on "Hydraulic Oil Change (Including Exchange of the Suction Filter in the Hydraulic Tank)" in "EVERY 1000 SERVICE HOURS" in "REGULAR CHECKS AND MAINTENANCE WORK" section.

\*2 Clean and replace the air filter more frequently if used under dusty conditions. When the filter is very dirty from dusty conditions, replace the filter.

\*3 Replace only if necessary.

\*4 Consult your local KUBOTA dealer for this service.

\*5 The maintenance identified with "\*5" is appeared on the meter panel at each specified maintenance hours.

● The items listed above (@ marked) are registered as emission related critical parts by KUBOTA in the U.S.EPA non-road emission regulation. As the engine owner, you are responsible for the performance of the required maintenance on the engine according to the above instruction. Please see the warranty Statement in detail.

## OPENING AND CLOSING OF PARTS

### ■ Opening and Closing of the Fuel Tank Cap

To open the fuel tank cap, turn clockwise.

To close it, turn counterclockwise.

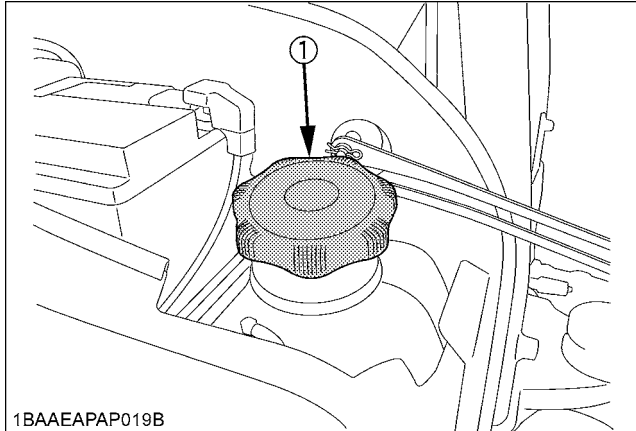

1BAAEAPAP019B

(1) Fuel tank cap

### ■ Opening/Closing of the Engine Hood

#### **WARNING**

To avoid personal injury or death:

- Do not open the engine hood with the engine running unless in an emergency.
- Do not touch the exhaust muffler or the exhaust pipe; serious burns can occur.

Insert the key into the key slot and turn it clockwise to unlock it. And pull the catch to open the hood.

To close the hood, push up the clasp and push the hood until it locks automatically.

Turn the key counterclockwise to lock the hood.

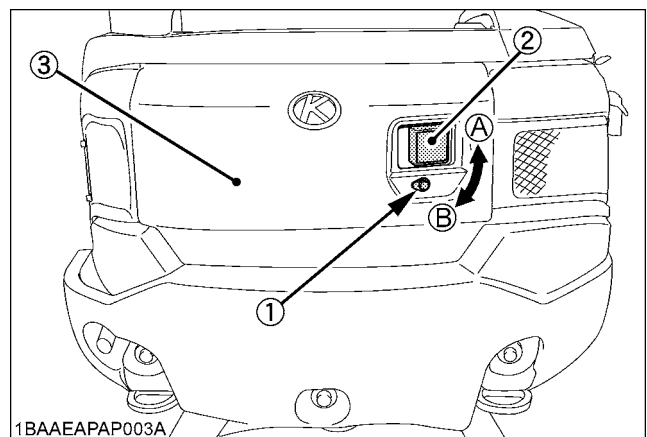

1BAAEAPAP003A

- (1) Key slot  
 (2) Catch  
 (3) Engine hood

- (A) "LOCK"  
 (B) "UNLOCK"

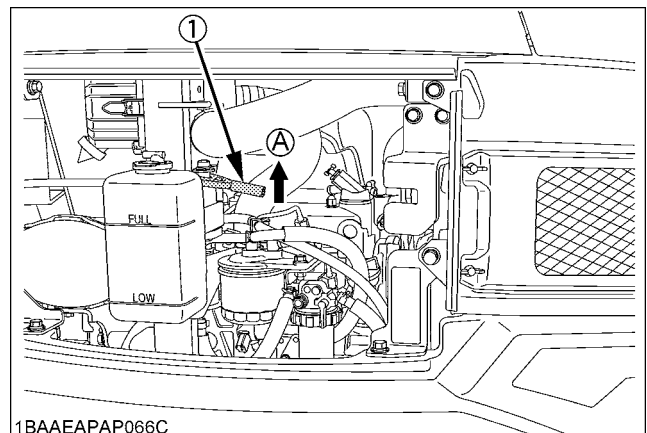

1BAAEAPAP066C

- (1) Clasp

- (A) Push up to close

**Opening/Closing of the Side Cover**

1. Insert the starter key in its hole and turn it clockwise to unlock the side cover. Pull and hold up the side cover until it is held by the link.
2. To close the side cover, push up the link, slide it left and lower the side cover until it clicks into its closed position.
3. Turn the starter key counterclockwise to get the side cover locked.

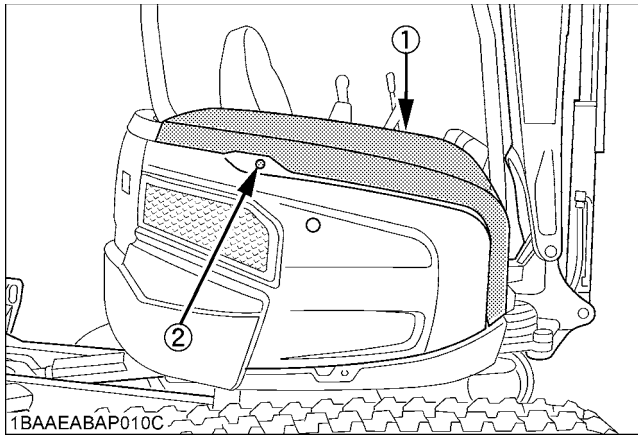

- (1) Side cover
- (2) Key hole

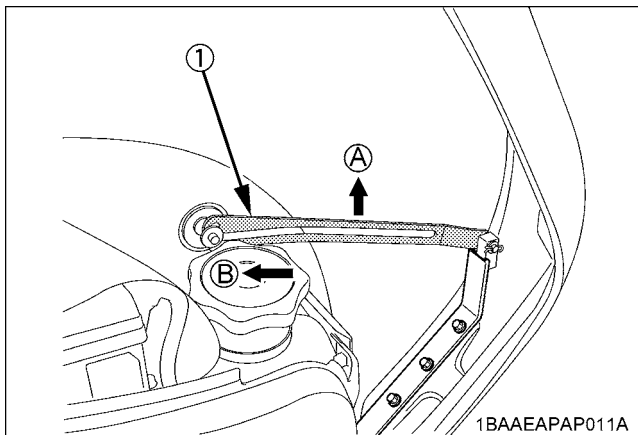

- (1) Link
- (A) Push up
- (B) Slide left

**Opening/Closing of the Radiator Cover**

Loosen the wing bolts and pull the radiator cover.

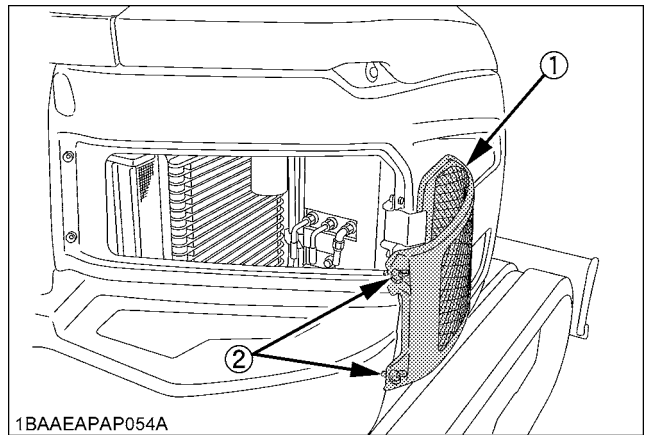

- (1) Radiator cover
- (2) Wing bolt

**Opening/Closing of the Swivel Frame Cover**

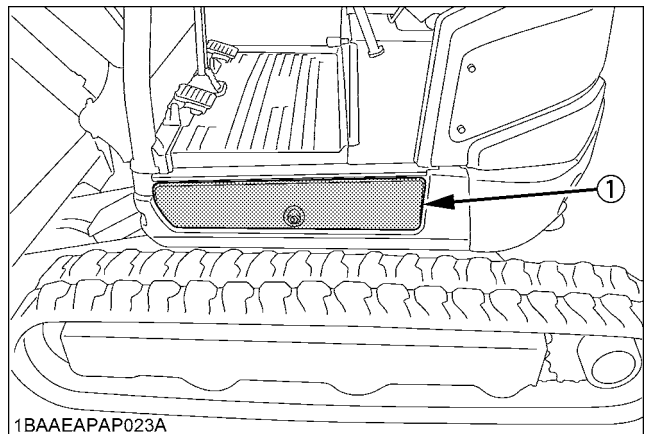

- (1) Swivel frame cover

**Where to store the Grease Gun**

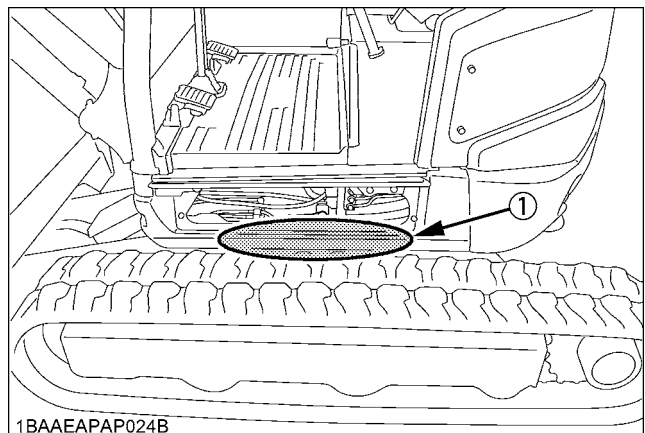

- (1) Grease gun storage



### ■ Where to keep Operator's Manual

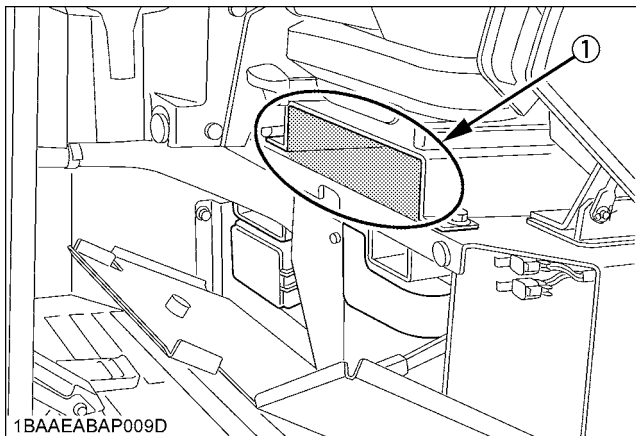

(1) Operator's manual storage

### ■ Cup Holder

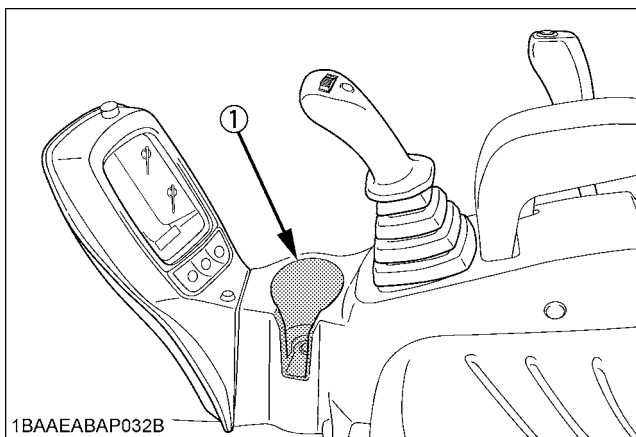

(1) Cup holder

## DAILY CHECKS

### ! WARNING

To avoid personal injury or death:

- When operating, keep hands and body inside of the ROPS / OPG (Top Guard Level I) protective envelope.
- Do not touch the control levers and the pedals from outside the cab while the engine is running.

For your own safety and to assure the long life of your machine, a careful check should be made before each operation.

### ■ Checking Coolant Level

### ! WARNING

To avoid personal injury or death:

- Move the excavator to even ground.
- Make sure that the engine is turned off.
- Do not open the radiator cap right after the engine has been stopped; Serious burns can occur from contact with escaping hot coolant fluid.
- Check the coolant level in the recovery tank only after the engine has cooled down.
- Remove the radiator cap only if absolutely necessary.

1. Check to see that the coolant level is between the "FULL" and "LOW" marks of the recovery tank.
2. When the coolant level drops due to evaporation, add water only up to the full level.  
In case of leakage, add anti-freeze and water in the specified mixing ratio up to the full level.  
(See "Changing Radiator Coolant" in every 2 years maintenance.)

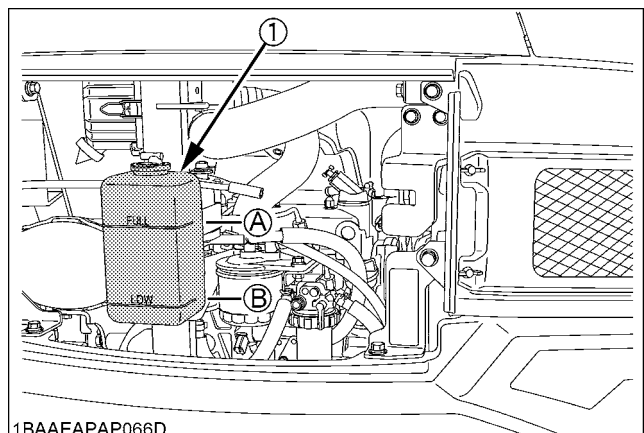

(1) Recovery tank

(A) "FULL"  
(B) "LOW"

### IMPORTANT :

- Do not fill the recovery tank over the "FULL" marking.
- Do not fill with dirty or salty water.

|                  |               |                     |
|------------------|---------------|---------------------|
| Coolant capacity | Radiator      | 2.4 L (0.54 US gal) |
|                  | Recovery tank | 0.6 L (0.16 US gal) |

### ■ Checking Fuel Level

#### **WARNING**

To avoid personal injury or death:

- Stop the engine and remove the key before fuelling.
- Do not smoke while fuelling.

#### IMPORTANT :

- By temperatures over -5°C (+23°F), use No.2-D diesel fuel, when temperatures are under -5°C (+23°F), use No.1-D diesel fuel.
- Make sure that the fuel tank will not run empty. Air will enter the fuel system, and must be purged before restarting the engine.
- See "PURGING FUEL SYSTEM" in "OTHER ADJUSTMENTS AND REPLACEMENTS" section.
- To prevent condensation (water) accumulations in the fuel tank, fill the fuel tank full before parking overnight.

1. Turn the starter key to the position "RUN".
2. Check the fuel level by the fuel level indicator.

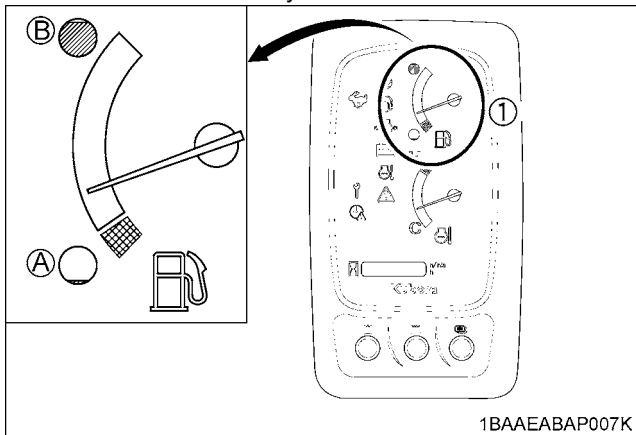

(1) Fuel gauge (A) "EMPTY" (B) "FULL"

3. Open the tank cap, and add fuel.

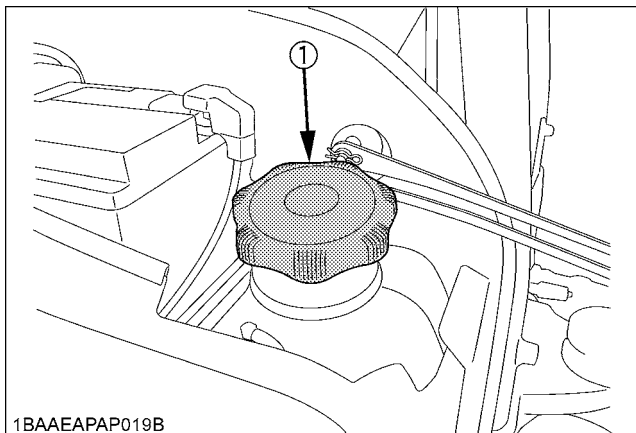

(1) Fuel tank cap

|                    |                   |
|--------------------|-------------------|
| Fuel tank capacity | 33 L (8.7 US gal) |
|--------------------|-------------------|

### ■ Checking Engine Oil Level

#### **WARNING**

To avoid personal injury or death:

- Stop the engine and remove the key before checking the oil level.

#### IMPORTANT :

- Use engine oil with the correct viscosity. (according to the outside temperature)
- After stopping the engine and remove the key, wait 5 minutes, then check oil level. (Excavator must be on level ground.)

Insert the engine oil dipstick fully into the respective port opening, remove again and check the oil level; if necessary fill with oil. The machine must be on level ground when checking the oil level.

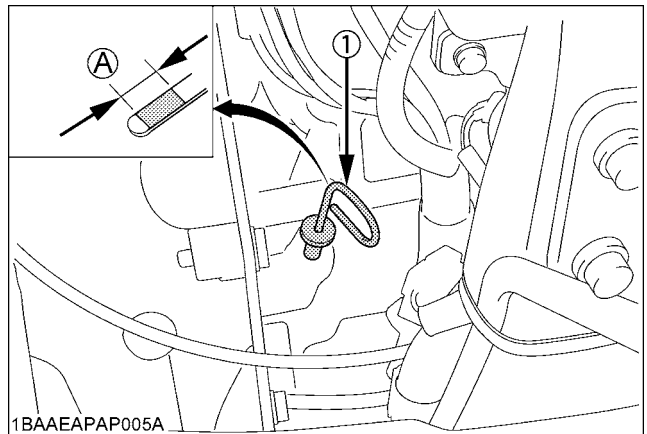

(1) Engine oil dipstick (A) Required level

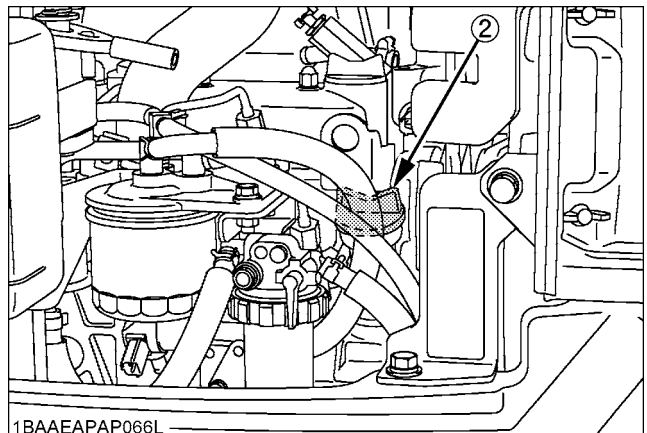

(2) Oil filling port

### ■Checking Hydraulic Oil Level

#### **WARNING**

To avoid personal injury or death:

- Stop the engine and remove the key before checking the oil level.

#### **IMPORTANT :**

- Before filling oil, wipe away all sand and dust from around the oil port. Make sure to use an identical type of hydraulic fluid.
- The excavator has been filled with hydraulic fluid before delivery. See "RECOMMENDED OILS" section.  
(Do not mix different oils.)

1. Park the excavator on a firm, flat and level surface. Lower the attachments and dozer blade to the ground and stop the engine.

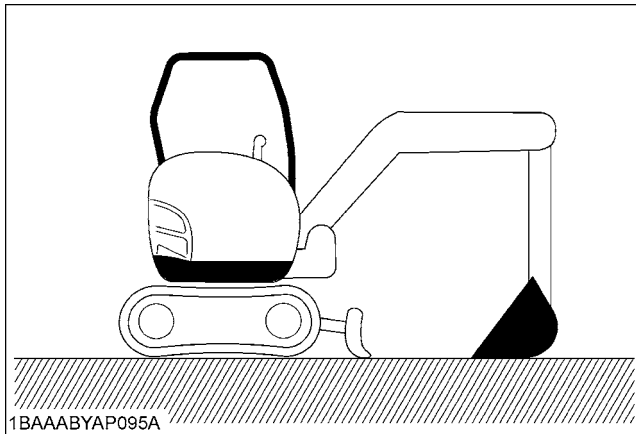

2. Check the oil level as to whether it lies on the center of the gauge at normal temperature (10 to 30°C).
3. Enough oil is present if the oil level lies near the center of the gauge.

4. Should the oil level be too low, fill oil through the oil port before starting the engine. This step is important for the protection of the hydraulic system.

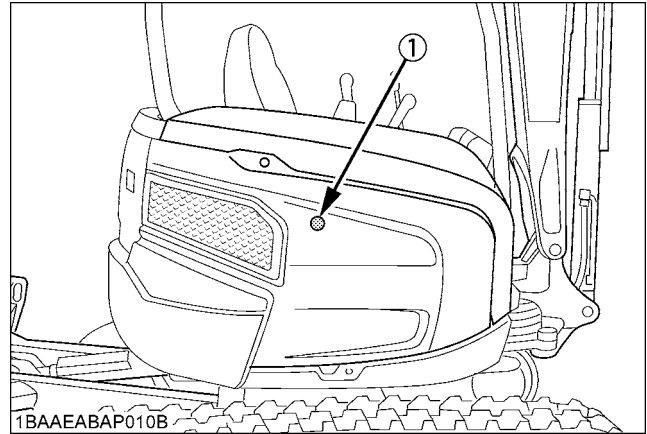

(1) Gauge

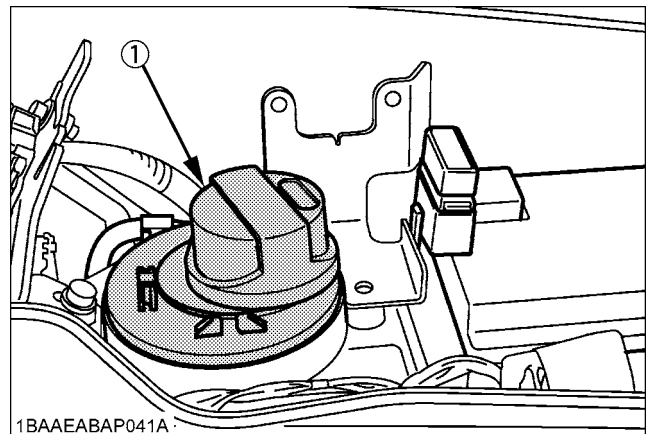

(1) Tank cap

|                        |                   |                    |
|------------------------|-------------------|--------------------|
| Hydraulic oil capacity | Hydraulic tank    | 22 L (5.8 US gal)  |
|                        | Whole oil volumes | 37 L (9.78 US gal) |

■ Lubrication Points



**WARNING**

To avoid personal injury or death:

- First lower all attachments on the ground then stop the engine and remove the key.
- While greasing, take care not to step on the bucket teeth.

**IMPORTANT :**

- When doing excavation work in water, generously grease the following points. After ending work, grease again.

Grease the marked grease fittings shown by arrows in the illustration below.

- |                                   |          |
|-----------------------------------|----------|
| 1. Boom bottom linkage.....       | 1 place  |
| 2. Arm bottom linkage.....        | 1 place  |
| 3. Bucket link pin (or boss)..... | 3 places |
| 4. Boom cylinder boss.....        | 2 places |
| 5. Arm cylinder boss.....         | 2 places |
| 6. Bucket cylinder boss.....      | 2 places |
| 7. Arm top linkage.....           | 1 place  |
| 8. Swing cylinder boss.....       | 1 place  |
| 9. Swing cylinder bottom.....     | 1 place  |
| 10. Swing pin.....                | 2 places |
| 11. Dozer cylinder boss.....      | 2 places |
| 12. Dozer linkage pin.....        | 2 places |

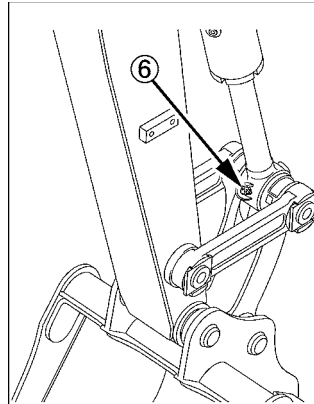

1BAAEAPAP062A

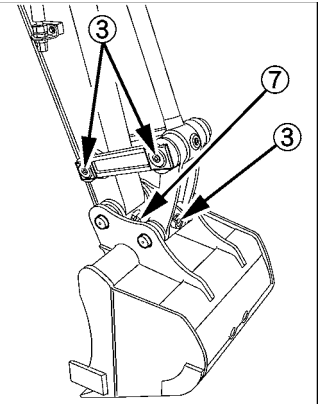

1BAAEAPAP040A

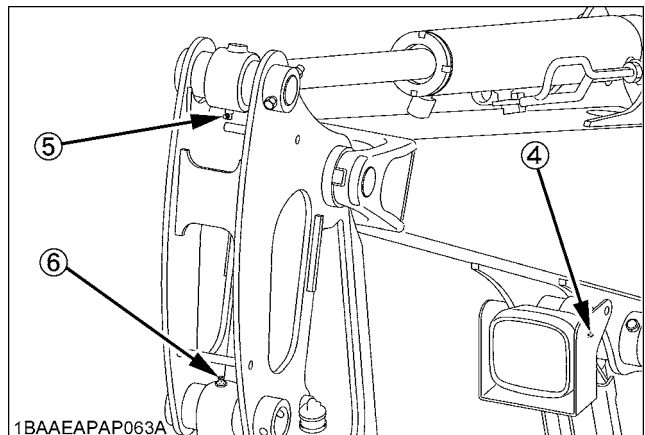

1BAAEAPAP063A

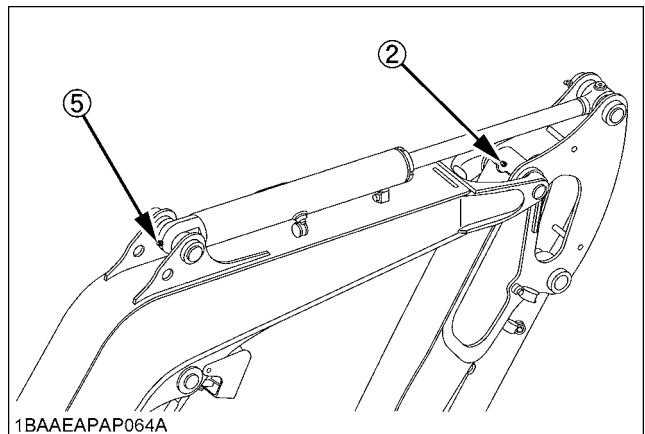

1BAAEAPAP064A

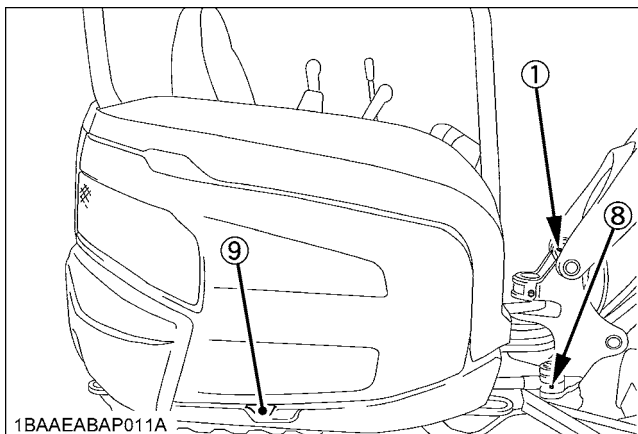

1BAAEABAP011A

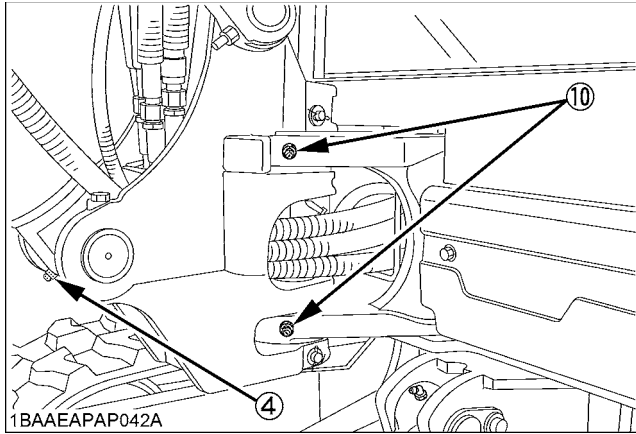

■ Check Fan Belt

**! WARNING**

To avoid personal injury or death:

- Stop the engine and remove the key before checking the fan belt.
- Check the fan belt for cracks and proper tension. (See "Checking Fan Belt Tension" in "REGULAR CHECKS AND MAINTENANCE WORK" section.)

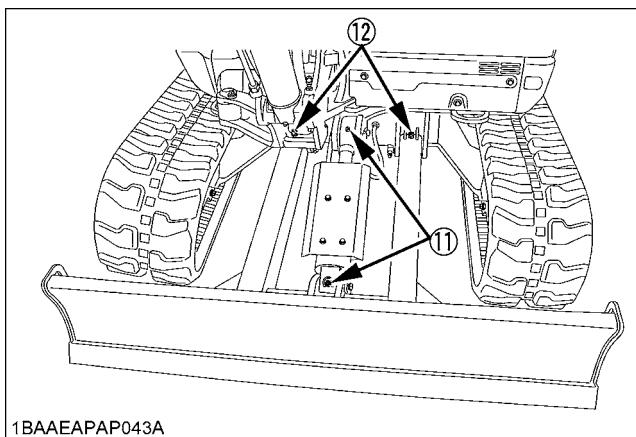

■ Checking Radiator and Oil Cooler

**! WARNING**

To avoid personal injury or death:

- Always stop the engine and remove the key before checking the radiator.
- Wear eye protection when cleaning with compressed air.

1. Check if the fins and ribs are clogged. If so clean with compressed air or steam.
2. Check the rubber hoses for damage and replace if cracked or old. Check if the hose clamps are tight enough.

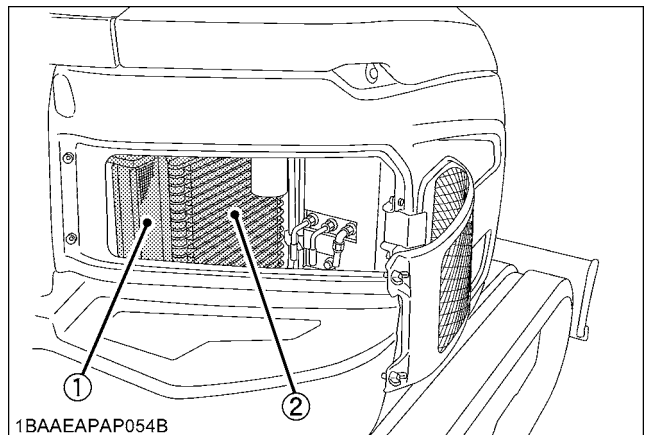

- (1) Radiator  
(2) Oil cooler

**IMPORTANT :**

- Radiator and oil cooler fins and ribs must be clean in order to avoid overheating the engine and to allow free flow of air through the cooling elements.
- Pressure of compressed air must be under 205 kPa (2.1 kgf.cm<sup>2</sup>, 30 psi)

### ■ Checking Washer Liquid (only for CAB type)

If the windows washer is switched on with the washer liquid tank empty, the motor may be damaged. Always keep the tank filled.

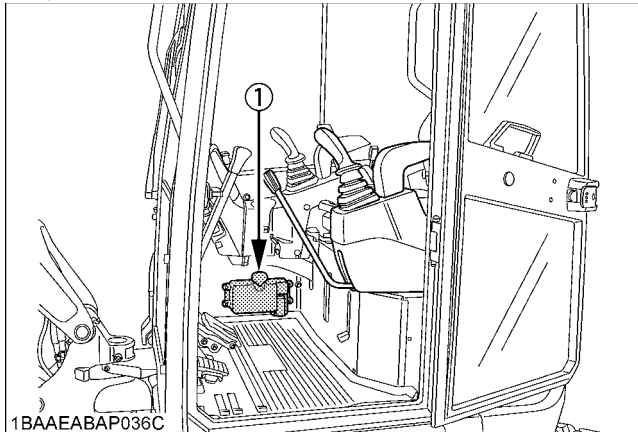

(1) Washer liquid tank

### ■ Checking and Cleaning Engine and Electrical Wiring



#### WARNING

To avoid personal injury or death:

- Always stop the engine and remove the key before cleaning the wiring, cables and engine.

Before starting, check whether flammable substances have gathered on the battery, the cables and wiring, the muffler or on the engine. Remove thoroughly.

Check the electrical circuitry for disconnections, shorts or loose terminals.

### ■ Washing Whole Machine

The incorrect use of a high-pressure wash may result in injuries or cause damage or breakdown of the machine. Use a high-pressure wash according to its instruction manual and labels.



#### CAUTION

To avoid personal injury:

Set the flushing nozzle to diffusion so as not to damage the machine, then wash from 2m away. Washing directly or from a close range may cause following.

1. It may damage the coating on the electrical wiring or disconnect the wires, which may cause fire.
2. Damage to the hydraulic hose may cause high-pressure oil to be ejected and cause injury.

3. It may cause damage or breakdown of the machine.

- Example)
- (1) Peeling of seals and labels
  - (2) Electronic components, engine Breakdown due to interior infiltration, etc.
  - (3) Damage to rubber, resin and glass parts such as tires, oil seals, etc.
  - (4) Peeling of paint and plated surface

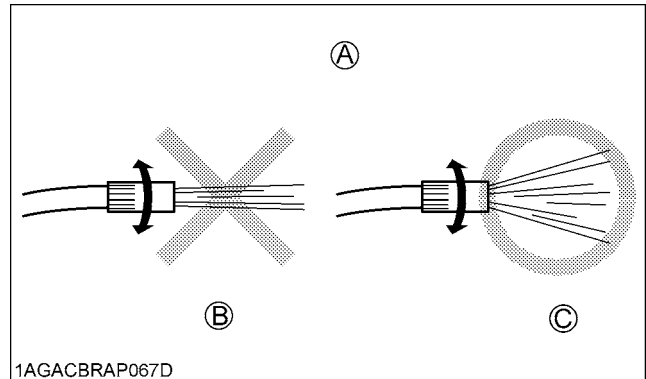

(A) Direct Wash Strictly Prohibited

(B) Direct

(C) Diffusion

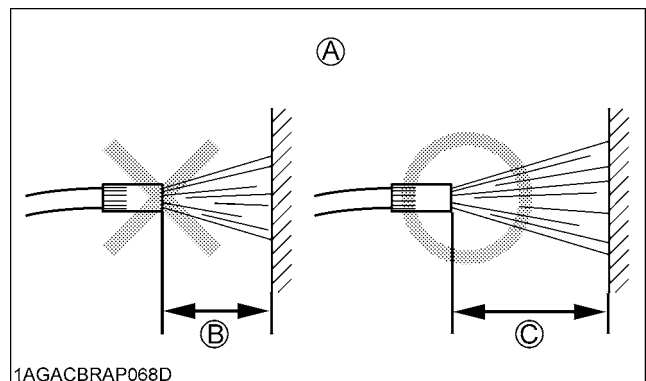

(A) Close-Range Wash Strictly Prohibited

(B) Less than 2m

(C) 2m or more

#### IMPORTANT :

- Do not wash the excavator with the engine running. Water could enter the air filter and damage the engine. Make sure that the air filter is kept dry.
- Remove the mud before washing the machine.

# REGULAR CHECKS AND MAINTENANCE WORK

## EVERY 50 SERVICE HOURS

### ■ Draining the Water from the Fuel Tank



#### WARNING

To avoid personal injury or death:

- Before draining the water from the fuel tank, be sure to stop the engine and remove the key.
- Do not smoke during inspection.

1. Turn the drain shutoff-valve to "CLOSED" position and remove the drain plug.
2. Turn the drain shutoff-valve to "OPEN" position and drain water.

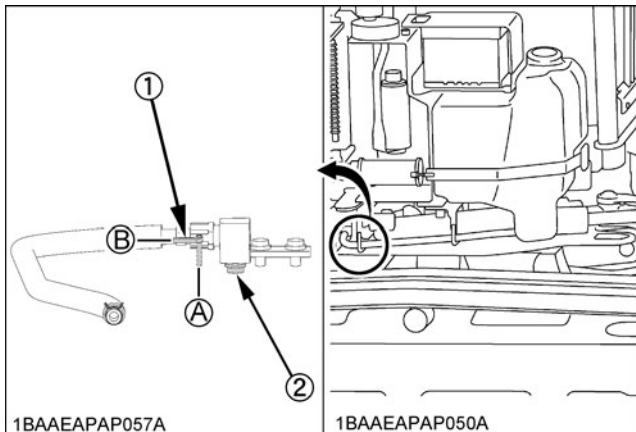

- 1BAAEAPAP057A
- (1) Drain shutoff-valve
  - (2) Drain plug

- 1BAAEAPAP050A
- (A) "CLOSED"
  - (B) "OPEN"

### ■ Draining Water Separator

1. Open the hood.
2. When the separated water is being drained, the red float moves upward. When the float reaches the indication line, close the shutoff-valve so that no fuel can run out. Now loosen the ring nut, and remove the cup and empty completely.
3. Clean carefully not to damage the filter element.
4. Finally, do not forget to open the shutoff-valve and close the hood.

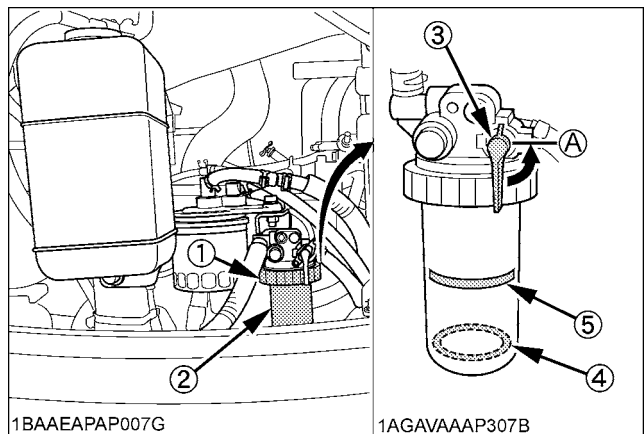

- 1BAAEAPAP007G
- (1) Ring nut
  - (2) Cup
  - (3) Shutoff-valve
  - (4) Float
  - (5) Line

- 1AGAVAAAP307B
- (A) "CLOSE"

■ Battery

**! DANGER**

To avoid the possibility of a battery explosion:  
For refillable type battery, follow the instructions below.

- Do not use or charge the refillable type battery if the fluid level is below the LOWER (lower limit level) mark. Otherwise, the battery component parts may prematurely deteriorate, which may shorten the battery's service life or cause an explosion. Check the fluid level regularly and add distilled water as required so that the fluid level is between the UPPER and LOWER levels.

**! WARNING**

To avoid personal injury or death:

- Never remove the vent caps while the engine is running.
- Keep electrolyte away from eyes, hands and clothes. If you are splattered with it, wash it away completely with water immediately and get medical attention.
- Wear eye protection and rubber gloves when working around the battery.
- Before inspection or dismantling the battery, be sure to turn off the engine and turn the starter switch to the "STOP" position.
- When removing the battery, always disconnect the negative ground cable first. When installing a battery, always connect the ground cable last. This prevents a possible explosion caused by sparks.
- Always wear eye protection when working with the battery.

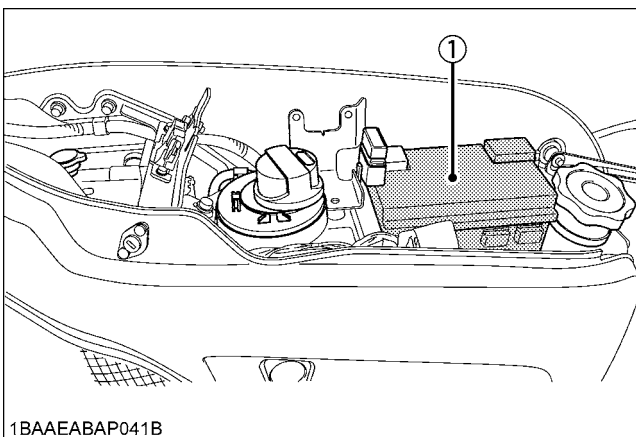

1BAAEABAP041B

(1) Battery

■ Battery Charging

**! WARNING**

To avoid personal injury or death :

- When the battery is being activated, hydrogen and oxygen gases in the battery are extremely explosive. Keep open sparks and flames away from the battery at all times, especially when charging the battery.
- When charging battery, remove battery vent plugs.
- When disconnecting the cable from the battery, start with the negative terminal first. When connecting the cable to the battery, start with the positive terminal first.
- Do not check battery charge by placing a metal object across the terminals. Use a voltmeter or hydrometer.

1. Make sure each electrolyte level is to the bottom of vent wells. If necessary add distilled water in a well-ventilated area.
2. The water in the electrolyte evaporates during recharging. Liquid shortage damages the battery. Excessive liquid spill damages the excavator body.
3. To slowly charge the battery, connect the battery positive terminal to the charger's positive terminal and the negative to the negative one. Then, recharge in the standard fashion.
4. A boost charge is only for emergencies. It will partially charge the battery at a high rate and in a short time. When using a boost-charged battery, it is necessary to recharge the battery as early as possible. Failure to do this will shorten the battery's service life.
5. When the specific gravity of electrolyte falls between 1.27 and 1.29, charge has completed.
6. When exchanging old battery for a new one, use battery of equal specification.

| Battery Type | Volts (V) | Capacity          |
|--------------|-----------|-------------------|
| 56219        | 12        | 55 (at 5H.R(A.H)) |

| Battery Type | Reserve Capacity (min) | Cold Cranking Amps | Normal Charging Rate (A) |
|--------------|------------------------|--------------------|--------------------------|
| 56219        | 103                    | 550                | 15                       |



### ◆ Direction for Storage

1. When storing the machine for long periods of time, remove the battery from machine, adjust the electrolyte to the proper level and store in a dry place out of direct sunlight.
2. The battery self-discharges while it is stored. Recharge it once every three months in hot seasons and once every six months in cold seasons.

### ■ Greasing of Swing Bearing Teeth

1. Pump grease with grease gun through the grease fitting.
2. Grease at each 90° (1.58 rad.) position of the swing frame.
3. Fill with approx. 50g of grease (approx. 20 pumps with the grease gun). Distribute the grease over the teeth.

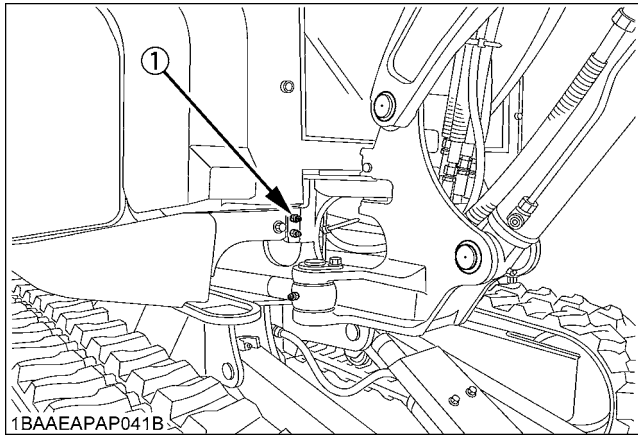

(1) Grease fitting (for Bearing teeth)

## EVERY 200 SERVICE HOURS

Do all 50 hour servicing at the same time.

### ■ Checking Fan Belt Tension

#### ◆ Check and adjustment of the fan belt tension



### WARNING

To avoid personal injury or death:

- First stop the engine and remove the key.
- After servicing, make sure to replace the belt cover in its original position.

1. Press the fan belt down in the middle, with a force of approx. 7 kg (15.41 lbs). The belt tension is correct if it deflects about 7 mm (0.28 in.). If otherwise, loosen nut (1) and bolt (2) and turn bolt (3) clockwise to shift the tension pulley (4) in the direction shown by the arrow.
2. Replace the fan belt if worn out, cracked or torn.

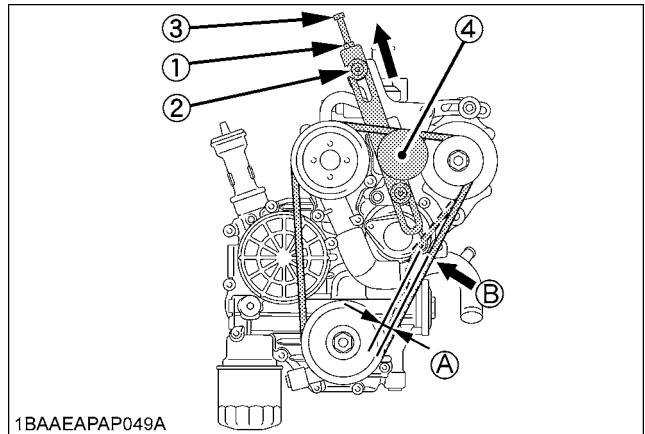

(1) Nut

(2) Bolt

(3) Bolt

(4) Tension pulley

(A) about 7 mm (0.28 in.)

(B) approx. 7 kg (15.41 lbs)

### IMPORTANT :

- If the engine is run with a loose fan belt, the belt could slip and cause overheating of the engine or insufficient battery charging. Check fan belt tension regularly.
- Should the fan belt break or jump off, the indicator light for battery charge will light up. Stop the engine and remove the key immediately.

## ■ Checking Radiator Hoses and Clamps



### WARNING

To avoid personal injury or death:

- Wait long enough for the radiator coolant to cool down.

Check the water hoses for proper connection. This check should be carried out every 200 hours or every 6 months, whichever comes first.

1. Should the hose clamps become loose or water leaks, tighten the hose clamps properly.
2. Should the radiator hoses become swollen, aged or cracked, they must be replaced and the hose clamps tightened again properly.

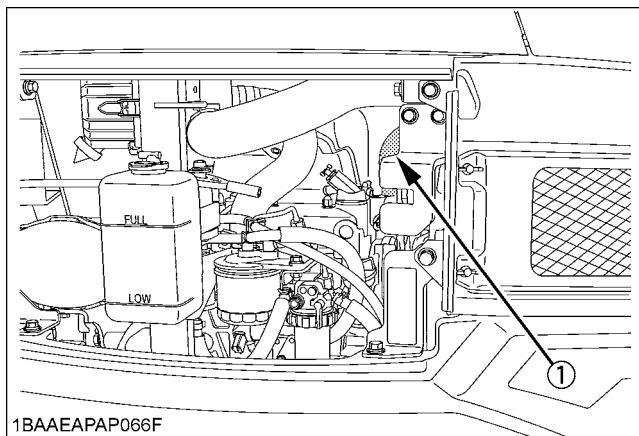

1BAAEAPAP066F

(1) Radiator hoses

## ■ Inspection and Cleaning Air Filter Element

Open the engine hood and remove the dust-cover. Take out only outer element, clean the element, case interior and reassemble. During reassembly, take care to install the dust-cover so that its TOP mark (arrow) faces upwards. Do not remove the inner element.

### IMPORTANT :

- Should the machine be used in extremely dusty areas, the air filter element must be inspected and cleaned more frequently than in the specified maintenance periods.
- The air filter has a dry element, keep free from oil.
- Do not run the engine without the air filter.

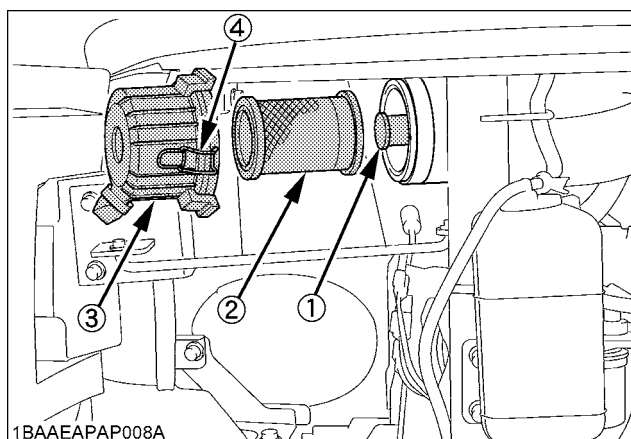

1BAAEAPAP008A

- (1) Inner element
- (2) Outer element
- (3) Dust-cover
- (4) Clamps

■ Air Filter Maintenance

**WARNING**  
 To avoid personal injury or death:  
 ● Wear eye protection.

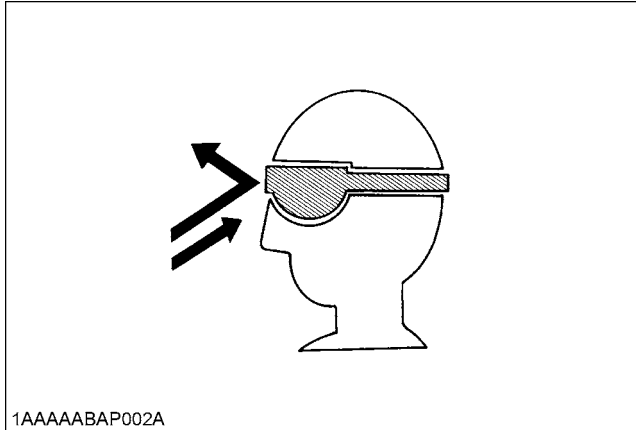

The quickest and safest method of maintenance is the exchange of the paper cartridge. Furthermore there are different methods of cleaning the cartridge.

◆ Cleaning with compressed air

Pressure of compressed air must be under 205 kPa (2.1 kg/cm<sup>2</sup>, 30 psi), and the cartridge should be blown clean from the inside to the outside until the dust deposits are remarkably reduced.

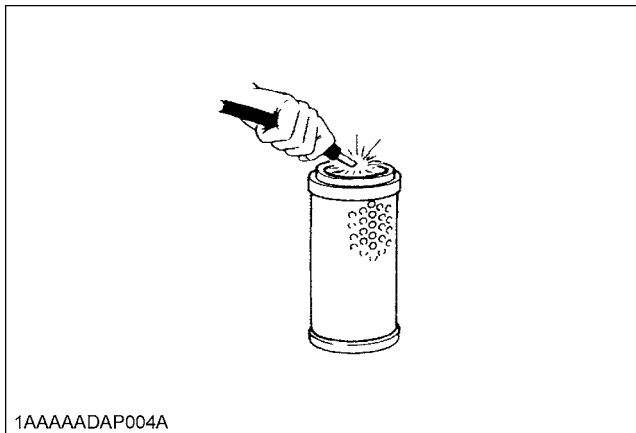

**IMPORTANT :**

● If the air suction is still inadequate, or the colour of the exhaust gases is abnormal even after the cleaning, the air filter element must be replaced.

■ Greasing Swing Bearing

1. Grease through the respective grease fitting. (at the lower fitting)
2. Grease at each 90° (1.58 rad.) position of the swing frame.
3. Using the grease gun, apply 5 shots at every position.

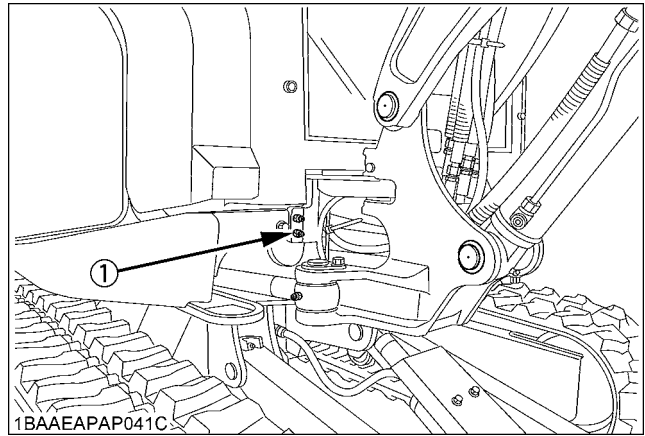

(1) Grease fitting

■ Checking Fuel Line and Intake Air Line

1. Check to see that all lines and hose clamps are tightened and not damaged.
2. If hoses and clamps are found worn or damaged, replace or repair them at once.

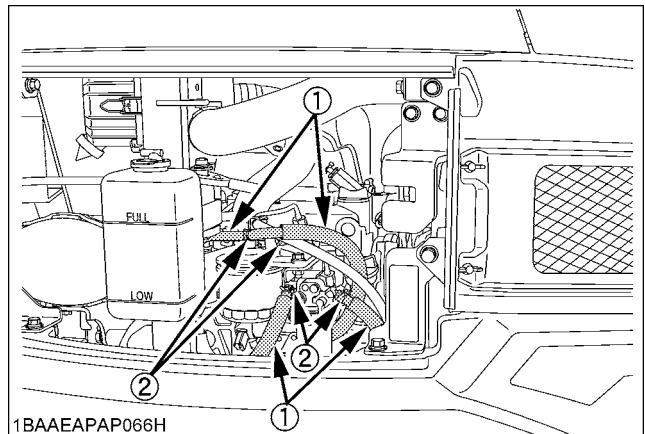

(1) Hoses  
 (2) Hose clamps

## EVERY 250 SERVICE HOURS

Do all 50 hour servicing at the same time.

### ■ Lubrication of the Pilot Valve

Remove the rubber bellows from the underside of the control levers. Grease the tip of the push rod and the rotating part of the link.

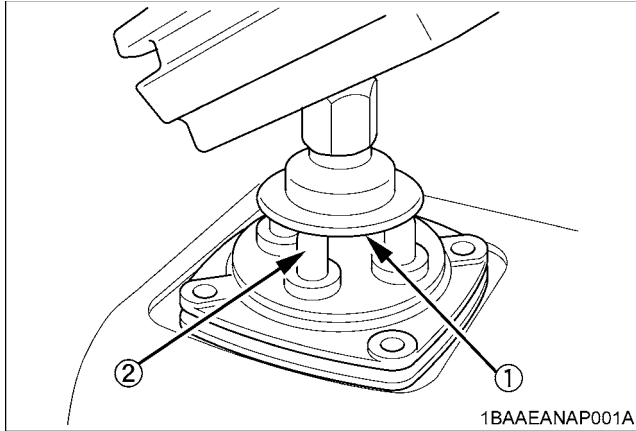

- (1) Rotating port of the link
- (2) Tip of the push rod

## EVERY 500 SERVICE HOURS

Do all 50 and 250 hour servicing at the same time.

### ■ Changing Engine Oil (Change the engine oil every 500 hours, or every 1 year in the case that service hour is less than 500 hours)



### WARNING

To avoid personal injury or death:

- First stop the engine then remove the key and wait long enough for the oil to cool down.

1. Remove the drain plug on the underside of the engine and drain all oil.
2. Re-tighten the drain plug.

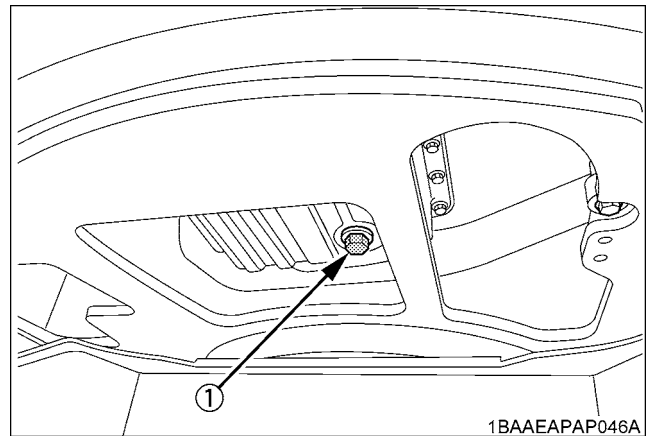

- (1) Drain plug

3. Fill up with new oil through the filling port to the specified level.

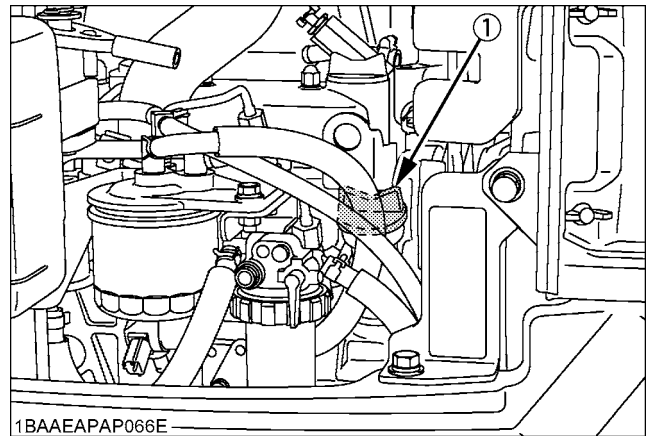

- (1) Oil filling port
- (A) Required oil level range
- (2) Engine oil dipstick

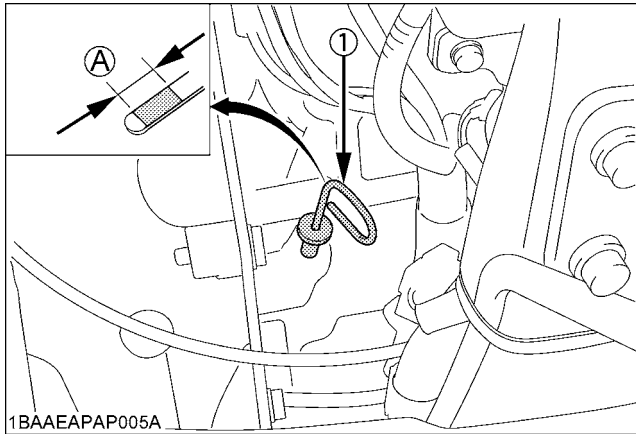

(1) Engine oil dipstick

(A) Oil level is acceptable within this range.

- Let the engine idle for approx. 5 min. Check the engine oil level. To check the engine oil level, insert the engine oil dipstick completely into the respective port opening and pull out again. If the oil level lies between both markings, no oil must be added.

**IMPORTANT :**

- Regardless of the service hours, an engine oil change is due every 6 month.

|   |                     |
|---|---------------------|
| Engine oil capacity<br>(with engine oil filter) | 4.4 L (1.16 US gal) |
|---|---------------------|

### ■ Replacing Engine Oil Filter Cartridge (Replace the engine oil filter cartridge every 500 hours, or every 1 year in the case that service hour is less than 500 hours)

- Replace the oil filter cartridge at the same time as doing the engine oil change.
- Remove the cartridge with the supplied filter wrench.

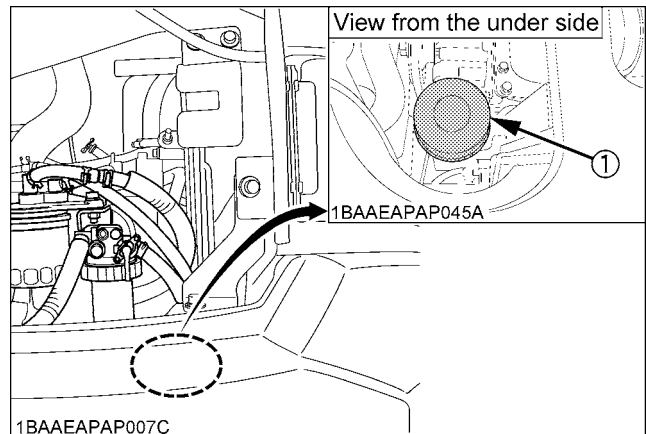

(1) Oil filter cartridge

- Oil the O-ring of the new oil filter cartridge lightly. Then tighten the oil filter cartridge by hand.
- Fill engine oil to the specified level.
- Let the engine run for approx. 5 min. and make sure that the engine oil indicator lamp does not light up. Then stop the engine and remove the key.
- The engine oil level is reduced by the amount of the filter capacity after the engine is started. It is necessary to add oil.

**IMPORTANT :**

- Always check the oil level after having exchanged the filter.

## ■ Drive unit Oil Change (First Oil Change of the 50 hours)



### WARNING

To avoid personal injury or death:

- Lower all attachments to the ground, stop the engine and remove the key before undertaking the oil change.

1. Rotate the track so that the drain plug of the drive unit is in the bottom position.
2. Remove the drain plug to let the oil run out. Screw in and tighten the drain plug again and fill with gear oil through the oil check port.
3. Fill oil until it overflows out of the oil check port.

|                   |                              |
|-------------------|------------------------------|
| Gear oil capacity | approx. 0.35 L (0.77 US gal) |
|-------------------|------------------------------|

### Oil change

- first oil change after 50 hrs
- then every 500 hrs
- or at least once a year

4. Use prescribed gear oil SAE 90.

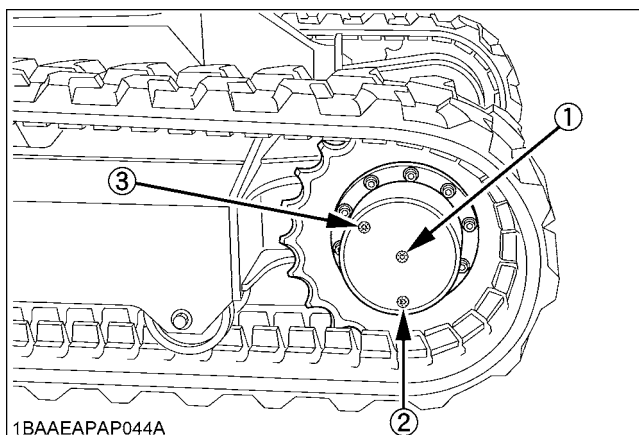

- (1) Oil check port
- (2) Drain port
- (3) Filling port

## ■ Replacing Fuel Filter Cartridge



### WARNING

To avoid personal injury or death:

- Keep fire away.

1. Remove the filter with the supplied filter wrench.
2. Add fuel to a new filter before installing.
3. Apply a light film of fuel to the seal of the new filter and turn in tightly by hand.
4. Open the shutoff-valve of the fuel filter again.

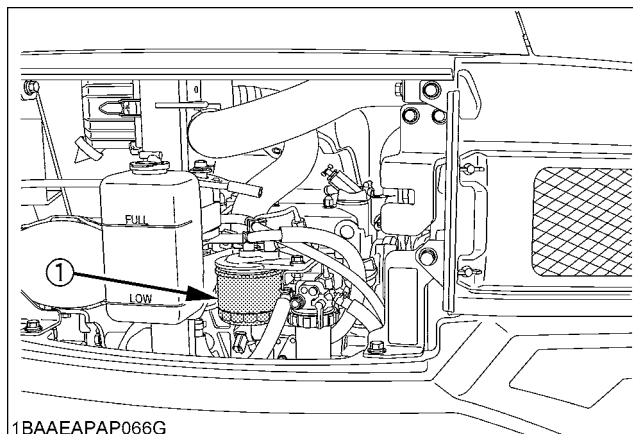

- (1) Fuel filter cartridge

### IMPORTANT :

- After exchange of the filter, the fuel system must be purged of air.

## ■ Replacing Hydraulic Return Filter Element



### WARNING

To avoid personal injury or death:

- Remove the oil filter element only after the oil in the hydraulic tank has cooled down.

1. Hold the filter support top and take the filter out of the tank.
2. Loosen the set bolt first and then detach the return filter from its support. Replace the filter with new one.
3. Remove the bolt from the cover. Take out and replace the breather filter with new one.

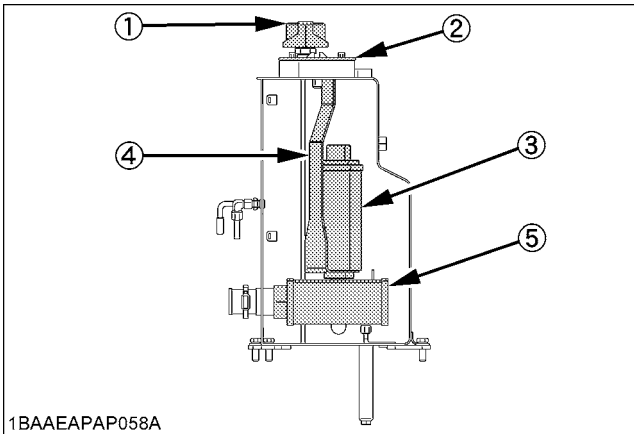

1BAAEAPAP058A

- (1) Breather filter
- (2) Cover
- (3) Return filter
- (4) Filter support
- (5) Suction filter

### IMPORTANT :

- Always check the oil level when replacing the filter.

## EVERY 1000 SERVICE HOURS

Do all 50, 200, 250 and 500 hour servicing at the same time.

## ■ Replacing the Hydraulic Pilot Filter Element



### WARNING

To avoid personal injury or death:

- Before replacing the element, wait long enough for the hydraulic fluid to cool down.

1. Remove four bolt and detach the left side cover.
2. Remove the pilot filter case from the head cover.
3. Wrench and pull out the element downward.
4. Replace the O-ring with a new one.
5. Apply a light coating of clean hydraulic oil to the O-ring and fit it to the case firmly. Be careful not to scratch the O-ring.
6. Fit the case to the head cover.
7. Let the engine run for approx. 3 minutes.
8. Check the oil level of hydraulic oil tank.

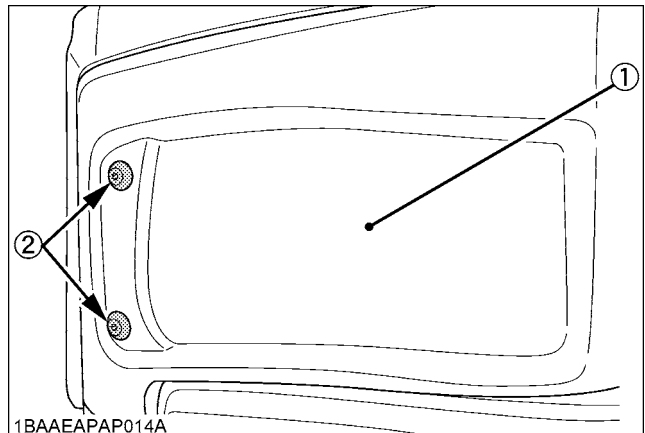

1BAAEAPAP014A

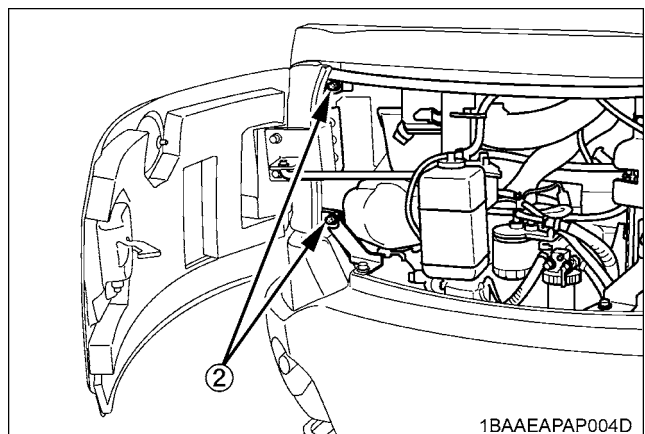

1BAAEAPAP004D

- (1) Left side cover
- (2) Bolt

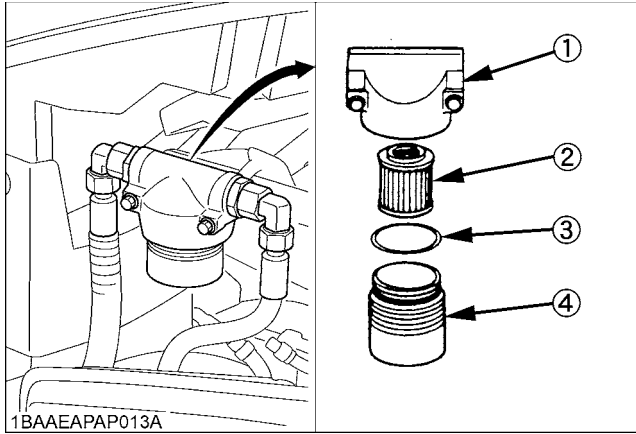

- (1) Head cover
- (2) Element
- (3) O-ring
- (4) Case

**Hydraulic Oil Change (Including Replacing of the Suction Filter in the Hydraulic Tank)**



**WARNING**

To avoid personal injury or death:

- Wait long enough for the hydraulic fluid to cool down. Then begin with the change of the hydraulic fluid.

1. Move the excavator to a level ground and stop the engine. Extend the piston rods of the cylinders halfway out and lower the bucket on the ground.

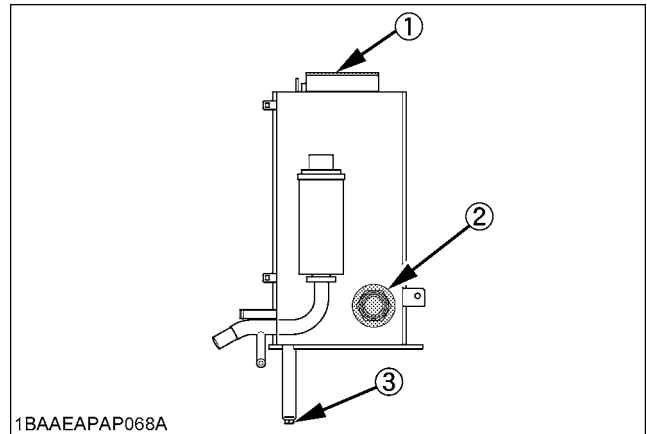
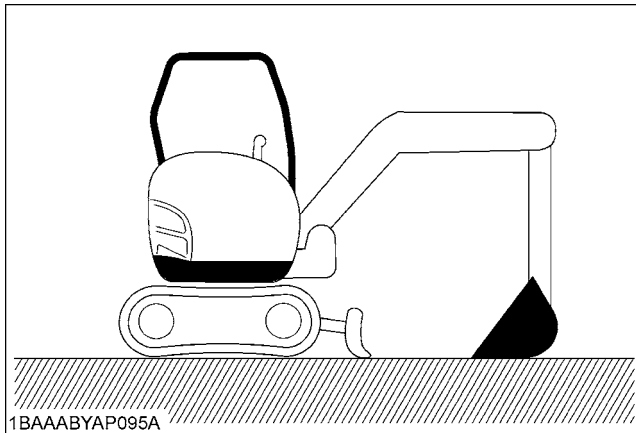

- (1) Cover
- (2) Suction filter
- (3) Drain plug

2. Remove the drain plug on the underside of the hydraulic tank and drain the oil.

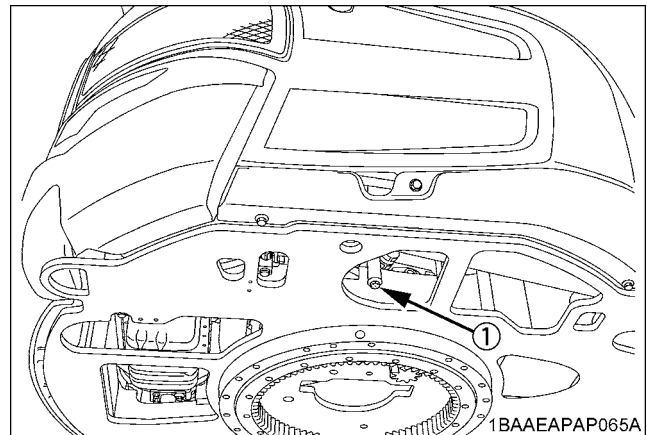

- (1) Drain plug

3. Remove the cover of the hydraulic tank.
4. With a fork wrench or similar, remove and exchange the suction filter.
5. Retighten the drain plug.
6. Fill oil through the oil filling opening on the top side of the tank.
7. Let the engine run for approx. 5 min. and check the oil level again.

|                        |                   |                    |
|------------------------|-------------------|--------------------|
| Hydraulic oil capacity | Hydraulic tank    | 22 L (5.8 US gal)  |
|                        | Whole oil volumes | 37 L (9.78 US gal) |



### Hydraulic Oil Check with Hydraulic Breakers

The hydraulic oil change after 1000 operating hours in the operator's manual is based on normal excavator work. Following inspection measures are valid when hydraulic breakers are used:

1. Changing and filling up of hydraulic oil
  - (1) The hydraulic oil must be changed more often when breakers are used because the machine is subject to harder conditions than at normal excavating work.
  - (2) Use only the recommended oils mentioned in the operator's manual when changing or fill oil.
  - (3) When filling up oil, do not mix oils of different makes.
2. Changing the return filter and oil
  - (1) The filter must be changed more often because of contamination resulting from the frequent assembly and disassembly of the hoses.
  - (2) Use the correct replacement filter.
  - (3) Oil change according to operating hours.

|                       |      | Hydraulic oil   | Return filter  |
|-----------------------|------|-----------------|----------------|
| Normal excavator work |      | every 1000 Hrs. | every 500 Hrs. |
| Breaker work portion  | 20%  | every 800 Hrs.  | every 200 Hrs. |
|                       | 40%  | every 400 Hrs.  |                |
|                       | 60%  | every 300 Hrs.  | every 100 Hrs. |
|                       | more | every 200 Hrs.  |                |

## EVERY 1000 SERVICE HOURS OR ONCE A YEAR

### Replacing Air Filter Element



#### WARNING

To avoid personal injury or death:

- First stop the engine and remove the key.

Open the engine hood and remove the dust-cover. Remove and replace the outer element and inner element with new elements.

When reassembling, install the dust-cover so that its TOP mark (arrow) faces up-wards.

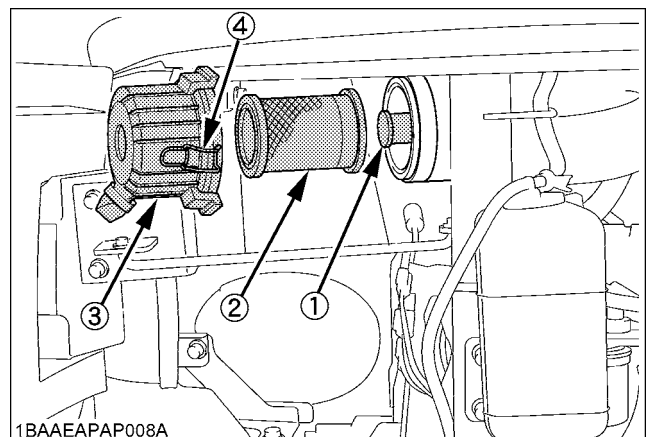

1BAAEAPAP008A

- (1) Inner element
- (2) Outer element
- (3) Dust-cover
- (4) Clamps

#### IMPORTANT :

- Shorten the replacement period if the machine is used in dusty or sandy areas.

## EVERY 1500 SERVICE HOURS

### Checking Fuel Injection Nozzle (Injection Pressure)

Consult your local KUBOTA dealer for this service.

## EVERY 2000 SERVICE HOURS

Do all 50, 200, 250, 500 and 1000 hour servicing at the same time.

### Changing Front Idler and Track Roller Oil

#### NOTE :

- Contact your KUBOTA dealer for details.

### Checking the Alternator and Starter Motor

#### NOTE :

- Contact your KUBOTA dealer for details.

## EVERY 3000 SERVICE HOURS

### ■ Checking Injection Pump

Consult your local KUBOTA dealer for this service.

## ANNUAL SERVICING



### WARNING

To avoid personal injury or death:

- Always check the wire harness and battery cord, as damage to these may cause a short circuit.
- Check for dust and fuel deposited on the battery, wiring, muffler and around the engine as they may cause fire.

### ■ Electrical Wiring and Fuses

Check the terminals periodically for proper connections. Loose wiring or damaged cables can cause improper functioning or short circuiting of the electrical system. Check wiring and replace damaged components immediately. If a fuse blows out soon after having been replaced, contact your nearest KUBOTA dealer. Never use a fuse other than specified.

### ■ Checking the Electrical Circuit

Check the electrical circuitry for disconnections, shorts or loose terminals.

## BIENNIAL SERVICING

### ■ Replacement of Radiator Hoses and Hose Clamps

Replace radiator hoses and hose clamps every two years. If the hoses are swollen, hard or cracked, they must be replaced earlier.

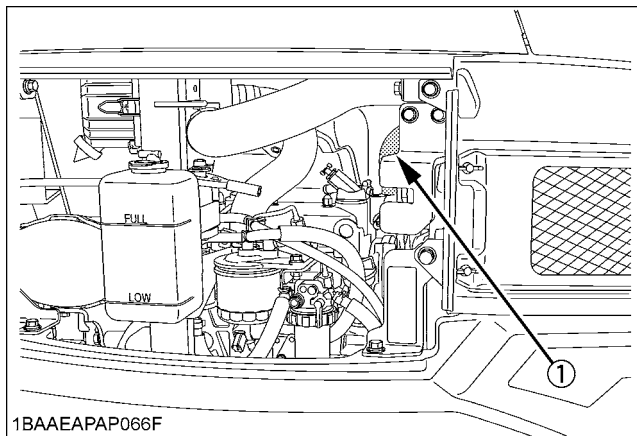

1BAAEAPAP066F

(1) Radiator hoses

### ■ Changing Radiator Coolant



### WARNING

To avoid personal injury or death:

- Do not loosen the radiator cap before the radiator has cooled down sufficiently. Then only loosen the cap and allow enough time for the pressure in the system to be released. Now remove the cap completely.
- When using anti-freeze, put on some protection such as rubber gloves. (Anti-freeze contains poison.)
- If you accidentally swallowed anti-freeze, seek medical attention at once.
- When anti-freeze comes in contact with the skin or clothing, wash it off immediately.
- Do not mix different types of Anti-freeze. The mixture can produce chemical reaction causing harmful substances.
- Anti-freeze is extremely flammable and explosive under certain conditions. Keep fire and children away from anti-freeze.
- When draining fluids from the engine, place some container underneath the engine body.
- Do not pour waste onto the grounds, down a drain, or into any water source.
- Also, observe the relevant environmental protection regulations when disposing of anti-freeze.
- If swallowed, anti-freeze is poisonous to people, animals and birds.

(In case of long-life coolant fluid)

Stop the engine then remove the key and wait until it has cooled down completely.

1. Open the drain plug or shutoff-valve on the bottom of the radiator and drain coolant completely.
2. To clean, rinse the radiator with water.
3. Close the drain plug or shutoff-valve and fill the radiator and the recovery tank with coolant fluid. Let the engine idle for about 5 min., stop the engine and check the coolant level then remove the key.
4. The machine has been shipped filled with 50% anti-freeze solution.

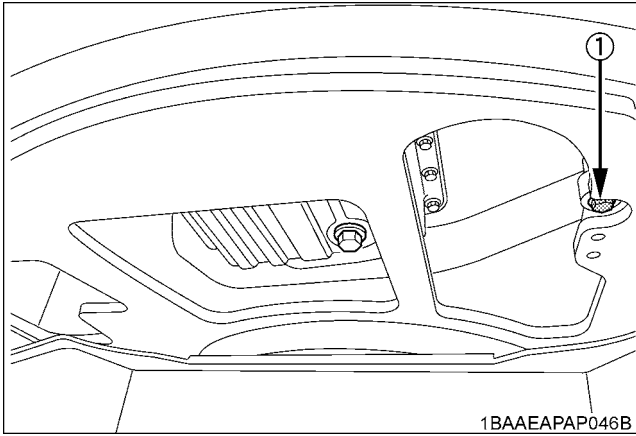

(1) Drain plug

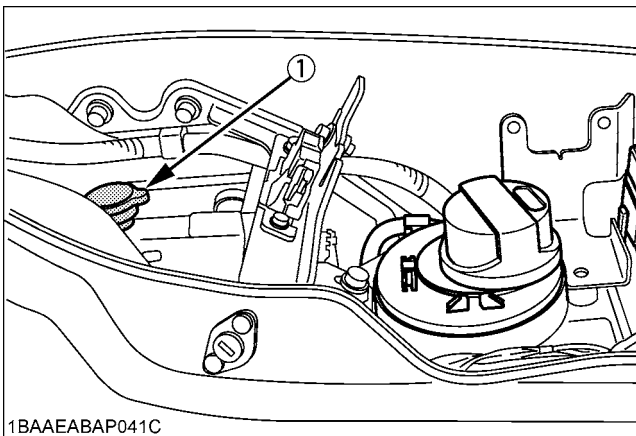

(1) Radiator cap

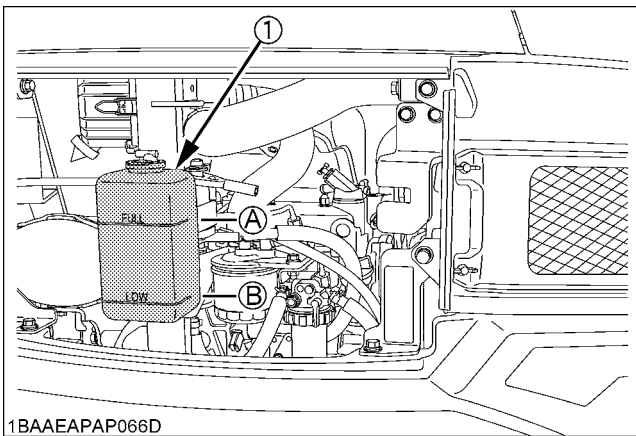

(1) Recovery tank  
(A) "FULL"  
(B) "LOW"

|                  |               |                     |
|------------------|---------------|---------------------|
| Coolant capacity | Radiator      | 2.4 L (0.54 US gal) |
|                  | Recovery tank | 0.6 L (0.16 US gal) |

**IMPORTANT :**

- Do not operate the engine without coolant.

- To fill the radiator system use fresh water and anti-freeze fluid.
- When the anti-freeze is mixed with water, the anti-freeze mixing ratio must be less than 50%.
- Tighten the radiator cap properly. If the cap is loosely or not properly fitted, overheating of the engine can result due to coolant fluid loss.

**■ Replacing Fuel Hoses and Hose Clamps**

Replace the hoses and clamps.

(See "Checking Fuel Line and Intake Air Line" in "EVERY 200 SERVICE HOURS")

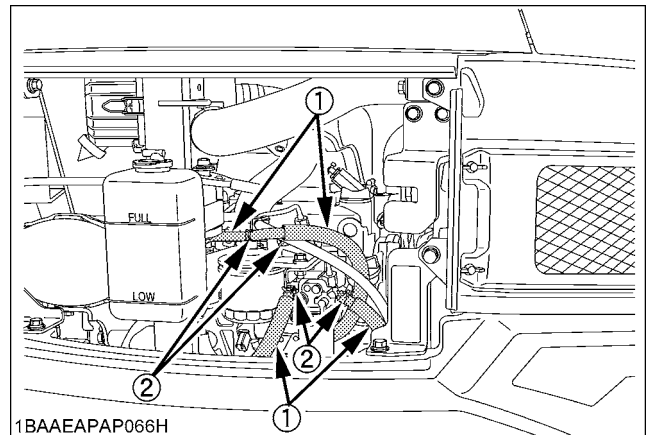

(1) Fuel lines  
(2) Clamp bands

**■ Replacing Intake Air line**

Replace the hoses and clamps, if necessary.

(See "Checking Fuel Line and Intake Air Line" in "EVERY 200 SERVICE HOURS")

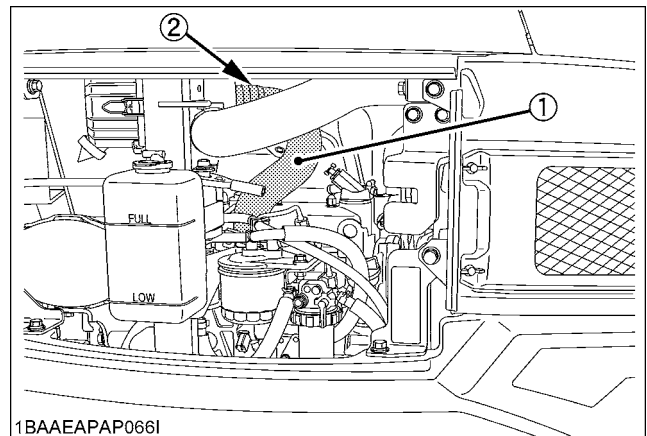

(1) Hoses  
(2) Hose clamps

# OTHER ADJUSTMENTS AND REPLACEMENTS

## PURGING OF THE FUEL SYSTEM

1. Fill up the fuel tank with fuel.
2. Turn the starter key to the position "RUN".
3. The air in the fuel system will automatically be purged within one minute.

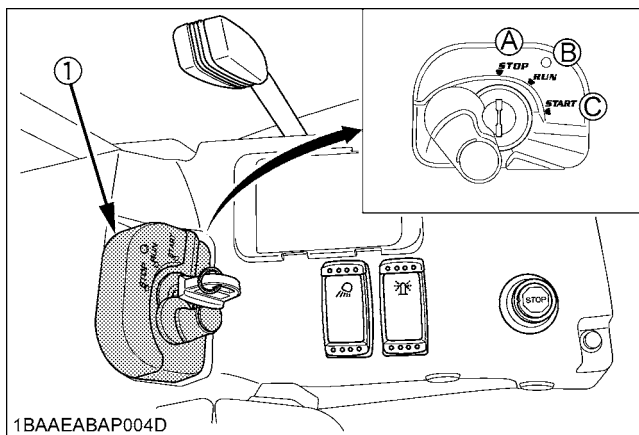

(1) Starter switch

(A) "STOP"

(B) "RUN"

(C) "START"

### IMPORTANT :

- If the purging was insufficient, the engine stops right after starting. In this case repeat steps 2 to 3 again.

## ADJUSTMENT OF TRACKS

- ◆ To loosen the tracks, follow the following procedure:



### WARNING

To avoid personal injury or death:

- Do not loosen the grease fitting completely or too quickly. Otherwise grease under high pressure in the tension cylinder could squirt out.
- Do not crawl under the excavator.

1. Using a socket wrench, loosen the grease fitting a few turns.
2. When grease oozes out from the thread, rotate the track and loosen the track in the lifted position (see illustration).

### After adjustment is completed:

Using the socket wrench, tighten the grease fitting. Tightening torque must be between 98 to 108 N-m.

### IMPORTANT :

- If the tracks are too tight, wear is increased.
- If the tracks are too loose, the track pads may collide with the sprocket and wear is increased. The track may dislocate or come off.
- Clean the track after every use.
- Should the track tension be high due to sticking mud, lift the track with the help of the boom, arm and bucket, idle the engine and remove mud from the track by rotating it.

### ◆ Tension the tracks as specified:

1. Apply grease (2) to the grease fitting (1).

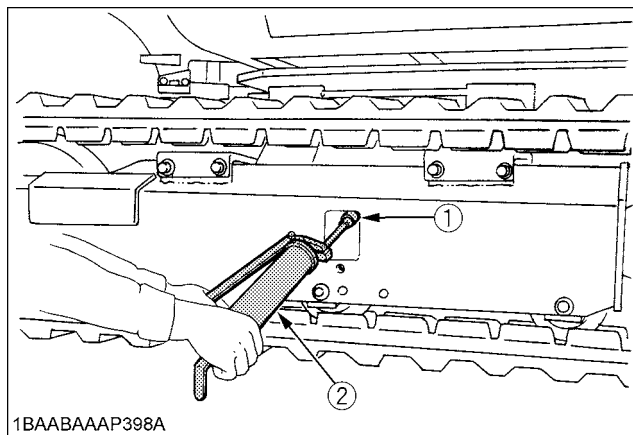

(1) Grease fitting

(2) Grease gun

### 2. Rubber Tracks

Tension the track in the lifted position, so that the distance "A" (clearance between the track roller and the inside surface of the track) see illustration, in this case, the track seam is positioned on the top center between the idler and the sprocket.

**DANGER**

To avoid serious injury or death:

- Do not work under the machine in this condition.
- For your safety do not rely on hydraulically supported devices, they may leak down and suddenly drop or be accidentally lowered.

**WARNING**

To avoid personal injury or death:

- When lifting the machine itself with an attachment, place a safety block or safety post to prevent the machine from turning over. Keep the pilot control lock lever in the "LOCKED" position.

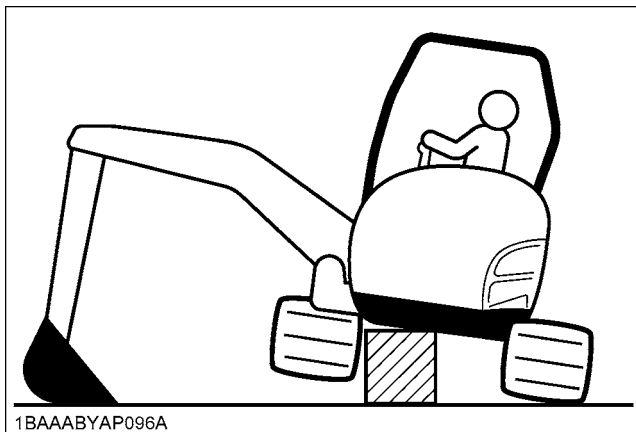
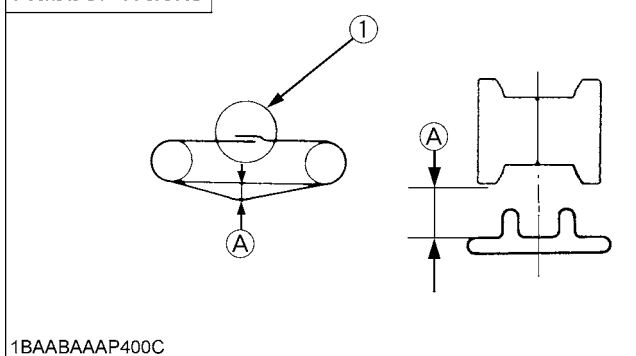
**Rubber Tracks**

(1) Seam (Mark "∞")

|     |                              |
|-----|------------------------------|
| (A) | 10 to 15 mm (0.4 to 0.6 in.) |
|-----|------------------------------|

**IMPORTANT :**

- Make sure that no obstacles, such as stones are caught in the track. Remove such obstacles before adjusting the track tension.
- Track seam  
The ends of the rubber track are joined with a seam. When adjusting the tracks, the seam must be positioned on the top center between the idler and the sprocket.

If the seam is positioned incorrectly, the tracks will be tensioned too loosely, and a further readjustment will be necessary.

- Rotate the track after adjustment one to two times to check the tension.
- Additionally following points are to be observed when adjusting rubber tracks.
  - (1) If the track loosen more than 25 mm (1.0 in.), readjust them.
  - (2) Check track tension 50 hours after initial use and readjust if necessary. Check and adjust thereafter every 50 service hours.

**Special Information when Using Rubber Tracks**

1. When turning, make a slow swing turn. Avoid spin turns to reduce lug wear and entry of dirt.
2. The relief valve may be activated if too much dirt and sand clog the tracks. In this case move the machine for a short distance straight backwards to let the earth and sand fall off, then a turn can be made.
3. Avoid using rubber track on riverbeds, stony underground, ferro-concrete and on iron plates. The rubber can damage as well as increase wear on the tracks.

## CHANGING THE BUCKET



### WARNING

To avoid personal injury or death:

- When the coupling pins are removed or installed, chips may come off. Always use gloves, goggles and a helmet.
- When the change of the equipment must be performed with the engine running, always work as a 2-person team. One person sits in the operator's seat and the other works on the machine.
- Do not use your fingers to center the holes, since they may be injured or even cut in case of sudden or uncontrolled movements.
- Read the manual of the attachment to do a correct operation safely when other attachments are installed instead of KUBOTA specified bucket.

## FUSES

### ■ Replacing Fuses

1. Remove the cover of the fuse box.
2. Replace the burnt out fuse with a fuse having the same capacity.

### ■ Fuse Capacities and Circuits

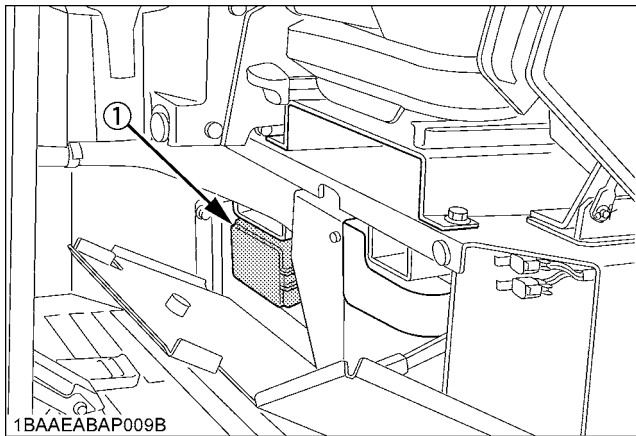

1BAAEABAP009B

(1) Fuse box

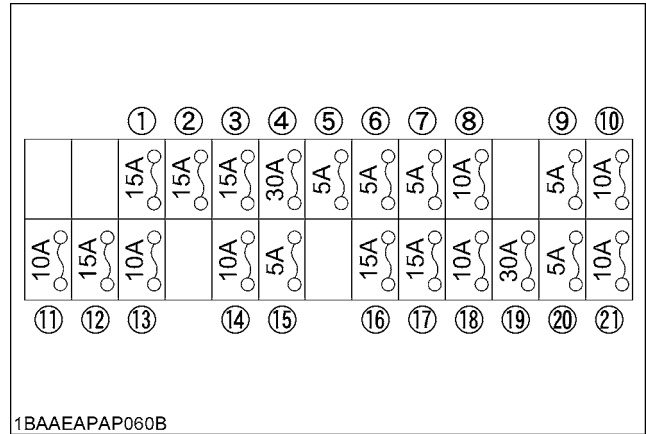

1BAAEAPAP060B

(1) Fuse box

|    |                       |    |                               |
|----|-----------------------|----|-------------------------------|
| 1  | Wiper / washer system | 12 | Electrical connection         |
| 2  | Radio (AC)            | 13 | Electrical connection 2       |
| 3  | 12-V socket           | 14 | Control unit (+B)             |
| 4  | Starter               | 15 | Interior lighting             |
| 5  | Starter (signal)      | 16 | Rotary beacon                 |
| 6  | Fuel pump             | 17 | Working lights                |
| 7  | Relay supply circuit  | 18 | Horn                          |
| 8  | Control unit (AC)     | 19 | Engine cut-off switch         |
| 9  | Control lever lock    | 20 | Horn switch                   |
| 10 | Alternator            | 21 | Display and control unit (+B) |
| 11 | Fan motor             |    |                               |

### ■ Slow Blow Fuse

Slow blow fuse is provided to protect the electrical circuits. If the slow blow fuse is blown, check the electrical circuits for trouble and then replace with a new compatible slow blow fuse.

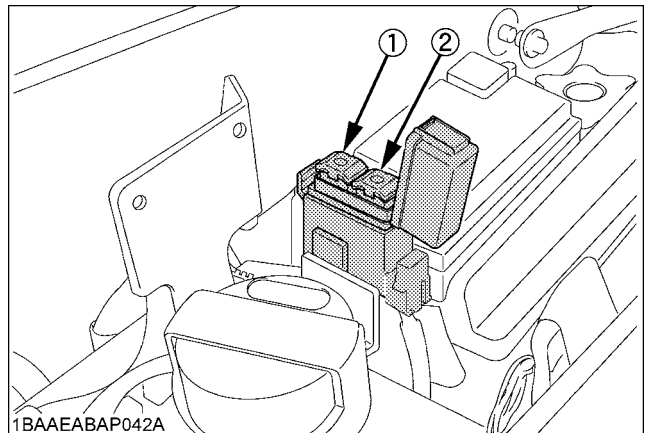

1BAAEABAP042A

(1) Slow blow fuse (50A)

(2) Slow blow fuse (60A)

# TROUBLESHOOTING

If the excavator does not show the desired performance, or when trouble arises, refer to the table below and undertake appropriate measures.









| Trouble                              |  | Cause  | Countermeasure   |
|--------------------------------------|--|--|--|
| Engine                               | Starting difficulties                                      | Fuel is too viscous  | *Check fuel tank and filter<br>*Remove impurities and water<br>*If necessary, replace filter   |
|                                      |  | Air or water in the fuel system  | *Remove water from the fuel tank<br>*Check fuel pipe joint bolts and nuts for looseness<br>*Purging of the fuel system (for fuel filter and injection pump, see "PURGING OF THE FUEL SYSTEM" in "OTHER ADJUSTMENTS AND REPLACEMENTS".) |
|                                      |  | Oil viscosity is too high the engine runs sluggishly in winter         | *Pour hot water over the radiator  |
|                                      |  | Battery is almost dead; insufficient compression                       | *Recharge battery  |
|                                      | Insufficient engine power                                  | Low fuel level   | *Check fuel and add if necessary   |
|                                      |  | Clogged air cleaner  | *Clean the air filter element  |
|                                      | Engine suddenly stops                                      | Low fuel level   | *Check fuel and add if necessary<br>*Purge the fuel system   |
|                                      | Abnormal exhaust gas color                                 | Poor fuel  | *Use high quality fuel   |
|                                      |  | Too much engine oil  | *Drain engine oil to prescribed oil level  |
|                                      | Water temperature too high (Overheating)                   | Worn or torn fan belt  | *Adjust or replace   |
|                                      |  | Coolant level too low  | *Fill to prescribed level  |
|                                      |  | Radiator grill or fins are clogged                                     | *Clean   |
|                                      |  | Coolant is contaminated with rust from the cylinder head or crank case | *Replace coolant fluid and add anti-rust   |
|                                      |  | Defective radiator cap (Evaporation)                                   | *Replace   |
|                                      |  | Corroded coolant pipes   | *Clean   |
| Continuous operation under full load |  | *Reduce load   |  |
| Engine oil level too low             |  | *Fill to prescribed level  |  |
| Use of poor fuel                     |  | *Use prescribed fuel   |  |
| Hydraulic System                     | Boom, arm, bucket, drive, swing and dozer power is too low | Hydraulic oil level too low  | *Add oil   |
|                                      |  | Leakages of hoses and / or joints                                      | *Replace hose or joint   |
|                                      | Swing motor and front attachment does not work             | Pilot control lock lever in "LOCKED" position                          | *Bring pilot control lock lever into "UNLOCK" position   |
| Drive System                         | Deviation of drive direction                               | Blocked through stones   | *Remove  |
|                                      |  | Track too loose or too tight   | *Adjust accordingly  |
|                                      | Drive lever does not move                                  | Pilot control lock lever in "LOCKED" position                          | *Bring pilot control lock lever into "UNLOCK" position   |





## KUBOTA I.C.S. NAVIGATION LIST OF MESSAGES







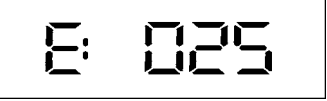

If an error occurs with the machine, one of the following messages appears in the LCD.  
In case of a trouble, immediately contact your local dealer for inspection and repair.

|   | LCD                                 | LED       | Problem / Error   | Preliminary Measure  | Solution  |
|---|-------------------------------------|-----------|---|--|---|
| 1 | CAN system error<br>                | <br>(red) | The Controller Area Network (CAN) has developed a fault. Measured values may be incorrect and switches may not function.      | The machine can be started and driven. Do not perform any work with the machine.   | Inform your KUBOTA dealer immediately.  |
| 2 | Feed fuel<br>                       |           | This message appears when the fuel level is low and prompts the operator to refuel.   | ---  | Refuel the excavator.   |
| 3 | Periodic check soon (notice)<br>    |           | This message appears 10 hours before the periodic check interval. This message means that the regular service is due shortly. | Operate the machine as usual.  | Ask your KUBOTA dealer about the relevant parts. Run the maintenance procedure. |
| 4 | Periodic check passed (warning)<br> |           | This message means that the regular service is due.   | The machine can be operated but service must be carried out urgently.              | Ask your KUBOTA dealer about the relevant parts. Run the maintenance procedure. |
| 5 | Warning temperature rising<br>      |           | The temperature of the coolant is higher than normal.   | Operate the machine only with reduced loads until the temperature is normal again. | ---   |
| 6 | ---                                 | ---       | ---   | ---  | ---   |
| 7 | ---                                 | ---       | ---   | ---  | ---   |
| 8 | ---                                 | ---       | ---   | ---  | ---   |

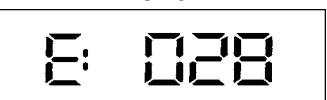

|    | LCD   | LED  | Problem / Error  | Solution #1  | Solution #2  |
|----|---|--|--|--|--|
| 9  | Clock setting request<br>No display item        |   | Power was interrupted and the clock now has to be set again. | In order to set the clock, press the user setting switch.  | ---  |
| 10 | ---   | ---  | ---  | ---  | ---  |
| 11 | Raise the control lever lock<br>No display item | <br>(yellow)  | This message indicates a step in a procedure.                | Raise the pilot control lock lever; the indicator goes out.  | ---  |
| 12 | ---   | ---  | ---  | ---  | ---  |
| 13 | Lower the control lever lock<br>No display item | <br>(yellow)  | This message indicates a step in a procedure.                | Lower the pilot control lock lever; the indicator goes out.  | ---  |
| 14 | Oil pressure too low<br>E: 014                  | <br>(red)<br>+<br>     | The engine oil pressure is too low.                          | Stop the engine immediately. The engine may have developed a fault.  | Inform your KUBOTA dealer immediately.   |
| 15 | Overheat<br>E: 015                              |   | The machine is overheated and must cool off by idling.       | Allow the machine to cool off by idling. Do not switch the engine off as the coolant could then boil over. | Clean the radiator and check the coolant. Refill the radiator with coolant by its boiled-over amount. Unclog the radiator and other components before use again. Check also the hydraulic system for oil leak and other troubles. If an oil leak is found, immediately contact your local dealer for repair. |
| 16 | Charging system error<br>E: 016                 | <br>(red)<br>+<br> | The charging system has developed a fault.                   | Check the V-belt. When the V-belt is OK, let the engine run until the indicator goes out.                  | If the indicator does not go out, inform your KUBOTA dealer immediately.   |

|    | LCD                                      | LED  | Problem / Error   | Solution #1   | Solution #2                            |
|----|--|--|---|---|--|
| 17 | Fuel sensor error<br>E: 017              | <br>(red) | The fuel sensor has developed a fault; the fuel gauge does not appear in the display.                               | Press the display selector switch to return to the default display.   | Inform your KUBOTA dealer immediately. |
| 18 | Water temperature sensor error<br>E: 018 | <br>(red) | The coolant temperature sensor has developed a fault; the coolant temperature gauge does not appear in the display. | Press the display selector switch to return to the default display. The functions of the machine are stable but overheating cannot be excluded. | Inform your KUBOTA dealer immediately. |
| 19 | ---                                      | ---  | ---   | ---   | ---                                    |
| 20 | Lever lock system error<br>E: 020        | <br>(red) | The electrical system in the pilot control lock lever has developed a fault.  | The engine can be started but the machine cannot be set in motion.  | Inform your KUBOTA dealer immediately. |
| 21 | Travel 2 speed system error<br>E: 021    | <br>(red) | The electrical system in the travel speed has developed a fault.  | The machine can only be set in motion at low speed.   | Inform your KUBOTA dealer immediately. |
| 22 | ---                                      | ---  | ---   | ---   | ---                                    |
| 23 | ---                                      | ---  | ---   | ---   | ---                                    |
| 24 | ---                                      | ---  | ---   | ---   | ---                                    |

|    | LCD   | LED  | Problem / Error   | Solution #1  | Solution #2  |
|----|---|--|---|--|--|
| 25 | <p>Overvoltage</p>                 | <br>(red)     | <p>This is a warning that a higher voltage (from a 24-V battery, for example) is being applied to the electric circuit, or that there is a problem with the alternator.</p> | <p>Switch the engine off immediately and check the battery and the alternator. Restart the engine.</p> | <p>If the indicator lights up again after restarting, inform your KUBOTA dealer immediately.</p> |
| 26 | ---   | ---  | ---   | ---  | ---  |
| 27 | <p>External 5-V system error</p>   | <br>(red)     | <p>The 5-V sensor supply line has developed a system fault. The main functions are not available.</p>   | <p>The machine can be started and driven. Do not perform any work with the machine.</p>                | <p>Inform your KUBOTA dealer immediately.</p>  |
| 28 | <p>External 12-V system error</p>  | <br>(red)     | <p>The 12-V sensor supply line has developed a system fault. The main functions are not available.</p>  | <p>The machine can be started and driven. Do not perform any work with the machine.</p>                | <p>Inform your KUBOTA dealer immediately.</p>  |
| 29 | <p>Starting the engine</p>       | <br>(yellow) | <p>This message indicates a step in a procedure.</p>  | <p>Start the engine; the indicator goes out.</p>   | ---  |

◆ **Service hour meter**

When the hour meter has counted up to the hours circled in the maintenance list below, the message appears. The message shows up as follows.

| No. | Check points                     |               | Measures | Hour meter indicator |     |     |     |     |     | Interval |                |
|-----|----------------------------------|---------------|----------|----------------------|-----|-----|-----|-----|-----|----------|----------------|
|     |                                  |               |          | 50                   | 100 | 250 | 500 | 600 | 750 |          | 1000           |
| 1   | Engine oil                       |               | change   |                      |     |     | ○   |     |     | ○        | every 500 hrs  |
| 2   | Hydraulic oil                    |               |          |                      |     |     |     |     |     | ○        | every 1000 hrs |
| 3   | Air filter element               | Outer element | replace  |                      |     |     |     |     |     | ○        | every 1000 hrs |
|     |                                  | Inner element |          |                      |     |     |     |     |     | ○        | every 1000 hrs |
| 4   | Drive unit oil                   |               | change   | ●                    |     |     | ○   |     |     | ○        | every 500 hrs  |
| 5   | Engine oil filter                |               | replace  |                      |     |     | ○   |     |     | ○        | every 500 hrs  |
| 6   | Hydraulic return element         |               |          |                      |     |     | ○   |     |     | ○        | every 500 hrs  |
| 7   | Hydraulic suction filter element |               |          |                      |     |     |     |     |     | ○        | every 1000 hrs |

● First operation

The indicator "Maintenance" shines when a service period is due.



(The message reappears on the hour meter designated next.)

**NOTE :**

- The maintenance indicator disappears automatically in about 10 seconds.
  - When the key is turned from "**STOP**" to "**RUN**", the maintenance indicator reappears and disappears again automatically in about 10 seconds.
  - When the key is turned from "**STOP**" to "**RUN**" repeatedly 10 times, the indicator disappears.
- ◆ In case the service hour meter replaced due to any trouble with it, the meter is set to "0". Contact your KUBOTA dealer for details.

# OPERATION UNDER COLD WEATHER CONDITIONS

## PREPARATION FOR OPERATION IN COLD WEATHER

1. Replace engine oil and hydraulic oil with those of viscosities suitable for cold weather.
2. In cold weather, battery power drops, and the battery fluid may freeze if the battery is not sufficiently charged. To prevent the battery fluid from freezing, be sure to keep the battery charged at least 75% or more of its capacity after operation. To ease next starting, it is recommended to keep the battery stored in closed or heated rooms. If the battery fluid level is too low, do not add after operation, but add with the engine running before the next operation.
3. Add anti-freeze to coolant in the radiator and recovery tank, if the ambient temperature is expected to drop below 0°C (32°F). Mixing ratio of water and anti-freeze is 50%/50%.

### IMPORTANT :

- Use permanent anti-freeze or long-life coolant.
- Drain the coolant completely and clean the radiator inside then fill with the water and anti-freeze mixture.
- As the anti-freeze also acts as an anti-corrosive, it is not necessary to add an additive to the water and anti-freeze mixture.
- See "Checking Coolant Level" under "DAILY CHECKS" in "MAINTENANCE" for radiator fill volumes.

## PROCEDURE AFTER COMPLETING WORK

Clean the excavator thoroughly after work and wipe dry. Otherwise mud and earth on the tracks could freeze if the temperature drops below the 0°C (32°F) mark. Operation of the excavator is then not possible. Store the excavator in a dry place; if not possible, store on wooden planks or on mats. If the excavator is kept on damp or muddy ground, the tracks could freeze overnight. Operation of the excavator is then not possible. Furthermore the drive unit may be damaged.

Additionally, the piston rods of the hydraulic cylinders must be rubbed dry. Otherwise severe damage could occur if dirty water seeps through the seals.

# LONG STORAGE



## WARNING

To avoid personal injury or death:

- Do not clean the excavator with the engine running.
- To avoid the danger of exhaust fume poisoning, do not operate the engine in a closed building without proper ventilation.
- When storing, remove the key from the starter switch to avoid unauthorized persons from operating the excavator and getting injured.
- Bring the excavator on a firm, flat, and level surface. Lower the attachments and dozer blade on the ground.

### ■ Should the Excavator be Stored for a Longer Period of Time, Observe Following Procedures:

1. The whole excavator should be cleaned thoroughly and in all cases stored indoors. If the excavator has to be kept outdoors, lay out wooden planks on an even ground, place the excavator on the planks and cover completely.
2. Do an oil change and grease the excavator.
3. Heavily grease the visible section of the piston rods.
4. Remove the battery and store indoors.
5. If it is expected that the temperature will sink below the 0°C (32°F ) mark, add anti-freeze or drain coolant completely.

### IMPORTANT :

- Wash the excavator after stopping the engine.  
If you wash the excavator while running the engine, splashing water gets into the air cleaner through its intake and cause engine damage.  
Careful, wash and do not splash water over the air cleaner while the engine is running.

### ■ Observe Following Procedures when the Machine is to be Operated after Long Storage.

1. Wipe off the grease from the hydraulic cylinder rods.
2. Turn on the engine and operate the attachments and the drive mechanisms under no load in order to circulate the hydraulic oil.  
(If the machine is stored for longer than one month, do steps 1 and 2 once every month.)

### Periodic replacement of important component parts

To ensure safety in operation, you are strongly requested to inspect and service the machine at regular intervals. For added safety, ask your KUBOTA dealer to replace the following important component parts periodically.

These parts are prone to degradation in material or subject to wear and tear with time. It is difficult to judge how much they have been affected at regular inspection. It is therefore necessary to replace them with new ones after a specified time of use, whether wear is visible or not.

If any of them is found to be worn before the specified use, they must be repaired or replaced the same as other parts.

If any of the hose clamps are found deformed or cracked, the hose clamps must also be replaced.

For the hydraulic hoses other than the ones to be replaced periodically, inspect them for the following points. If found loose or very worn, tighten and / or replace the hose.

When replacing the hydraulic hoses, change their O rings and sealing components with new ones.

For replacement of the important parts, contact your KUBOTA dealer.

- At the following periodic inspections, check the fuel hoses and hydraulic hoses as well.

| Inspection Interval | Check points  |
|---------------------|---|
| Daily Checks        | Oil leak at fuel and hydraulic hose connections and points  |
| Every month         | Oil leak at fuel and hydraulic hose connections and points<br>Damages at fuel and hydraulic hose (cracks, chafing)  |
| Every year          | Oil leak at fuel and hydraulic hose connections and points<br>Interference, deformation, degradation, twist and other damages (cracks, chafing) of fuel and hydraulic hoses |

### List of important component parts

| No. | Component parts                  | Used place                     | Q'ty | Period                         |
|-----|----------------------------------|--------------------------------|------|--------------------------------|
| 1   | Fuel hose                        | Fuel tank - Water separator    | 1    | Every 2 years or<br>4000 hours |
|     |                                  | Water separator - Fuel pump    | 1    |                                |
|     |                                  | Fuel pump - Fuel filter        | 1    |                                |
|     |                                  | Fuel filter - Fuel nozzle      | 2    |                                |
|     |                                  | Fuel nozzle - Fuel tank        | 2    |                                |
| 2   | Hydraulic hose (suction)         | Tank - Main pump               | 1    |                                |
| 3   | Hydraulic hose (delivery)        | Main pump - Control valve      | 3    |                                |
|     |                                  | Main pump - Pilot filter       | 1    |                                |
|     |                                  | Pilot filter - Change valve    | 2    |                                |
| 4   | Hydraulic hose (Boom cylinder)   | Control valve - Boom cylinder  | *2   |                                |
| 5   | Hydraulic hose (Arm cylinder)    | Control valve - Hose joint     | *2   |                                |
|     |                                  | Hose joint - Arm cylinder      | *2   |                                |
| 6   | Hydraulic hose (Bucket cylinder) | Control valve - Hose joint     | *2   |                                |
|     |                                  | Hose joint - Bucket cylinder   | *2   |                                |
| 7   | Hydraulic hose (Swing cylinder)  | Control valve - Swing cylinder | 2    |                                |
| 8   | Hydraulic hose (Dozer cylinder)  | Control valve - Rotary joint   | 2    |                                |
|     |                                  | Rotary joint - Adapter         | 2    |                                |
|     |                                  | Adapter - Dozer cylinder       | 2    |                                |
| 9   | Hydraulic hose (Service port)    | Control valve - Hose joint     | 2    |                                |
|     |                                  | Hose joint - Adapter           | 2    |                                |
| 10  | Hydraulic hose (Swivel motor)    | Control valve - Swivel motor   | 2    |                                |

To prevent serious damage to the hydraulic system, use only a KUBOTA genuine hydraulic hose.

# RECOMMENDED OILS

**IMPORTANT :**

- Other than the oil mentioned below, JCMAS HK certified oil and GK certified grease can also be used. Check the Japan Lubricating Oil Society (JALOS) website for more details.

|               | Recommendation                                |                            |  | Filled at the factory |                                       | Note   |
|---------------|---|----------------------------|--|-----------------------|---------------------------------------|--|
|               | Ambient temperature conditions                | Viscosity                  | Quality standard   | Brand                 | Type                                  |  |
| Engine oil    | In winter and/or at low temperatures          | SAE 10W<br>SAE 20W         | API CI-4   |                       |                                       | When diesel fuel with a high sulphur content (between 0.50 % and 1.00 %) is used, the engine oil and engine oil filter must be replaced at shorter intervals.<br><br>Never use diesel fuel with a sulphur content exceeding 1.00 %.                            |
|               | In summer and/or at high ambient temperatures | SAE 30<br>SAE 40<br>SAE 50 |  |                       |                                       |  |
|               | All-weather                                   | 15W-40*                    |  | Shell                 | Rimula R4L*                           |  |
| Coolant       |   |                            | G048*<br>SAE J1034*<br>MB 325.0*<br>ASTM D3306*<br>D4985 | ROWE                  | Hightec<br>Antifreeze AN<br>(-37 °C)* | Always use distilled water to mix with antifreeze.<br>Always follow the recommendations of the coolant manufacturer for the mixing ratio. Do not mix with other coolants.  |
| Grease        |   | NLGI-2*                    | DIN 51825<br>KP2K-30*                                    | Mobil                 | Mobilux EP2*                          |  |
|               |   | NLGI-1                     |  | WEICON                | Antiseize<br>Standard                 | Only use during the first 50 working hours (on all greasing points around the swing block).  |
| Hydraulic oil | In winter and/or at low temperatures          | ISO 32<br>ISO 46*          |  | Shell                 | Tellus<br>S2M46*                      |  |
|               | In summer and/or at high ambient temperatures | ISO 46<br>ISO 68           |  |                       |                                       |  |
| Gear oil      | In winter and/or at low temperatures          | SAE 75<br>SAE 80           | MIL-L-2105C*   |                       |                                       |  |
|               | In summer and/or at high ambient temperatures | SAE 90<br>SAE 140          |  |                       |                                       |  |
|               | All-weather                                   | 80W-90*                    |  | Shell                 | Spirax<br>MA80W*                      |  |
| Diesel        |   |                            | EN 590<br>ASTM D975                                      |                       |                                       | The fuel filled at the factory is not winter diesel. For preparing the excavator for use in winter, fill the fuel tank with winter diesel and allow the engine to run for a few minutes.<br><br>Never use diesel fuel with a sulphur content exceeding 1.00 %. |
| Refrigerant   |   |                            | HFC R134a  |                       |                                       |  |

\* This lubricant is filled while manufacturing the engine.



**NOTE :**

◆ **Engine Oil:**

- Oil used in the engine should have an American Petroleum Institute (API) service classification and Proper SAE Engine Oil according to the ambient temperatures.

|                                |                                   |
|--------------------------------|-----------------------------------|
| Above 25 °C (77 °F)            | SAE 30 or SAE 10W-30, SAE 15W-40  |
| 0 °C to 25 °C (32 °F to 77 °F) | SAE 20 or SAE 10W-30, SAE 15W-40  |
| Below 0 °C (32 °F)             | SAE 10W or SAE 10W-30, SAE 15W-40 |

- Refer to the following table for the suitable API classification engine oil according to the engine type (with internal EGR, external EGR or non-EGR) and the fuel.

| Fuel used                                    | Engine oil classification (API classification) |   |
|--|--|---|
|  | Oil class of engines except external EGR       | Oil class of engines with external EGR  |
| Ultra Low Sulfur Fuel<br>[<0.0015% (15 ppm)] | <b>CG-4, CH-4 or CI-4</b>                      | <b>CI-4</b><br>(Class CG-4 and CH-4 engine oils cannot be used on EGR type engines) |

EGR: Exhaust Gas Re-circulation

- The CJ-4 engine oil is intended for DPF (Diesel Particulate Filter) type engines, and cannot be used on this machine.

|       | except external EGR | with external EGR |
|-------|---------------------|-------------------|
| Model | U27-4               | ---               |

◆ **Fuel:**

- Cetane number of 45 is minimum. Cetane number greater than 50 is preferred, especially for temperatures below -20 °C (-4 °F) or elevations above 1500 m (5000 ft).
- Diesel fuels specified to EN 590 or ASTM D975 are recommended.
- No.2-D is a distillate fuel of lower volatility for engines in industrial and heavy mobile service. (SAE J313 JUN87)

# MAIN DIMENSIONS

[CANOPY TYPE]

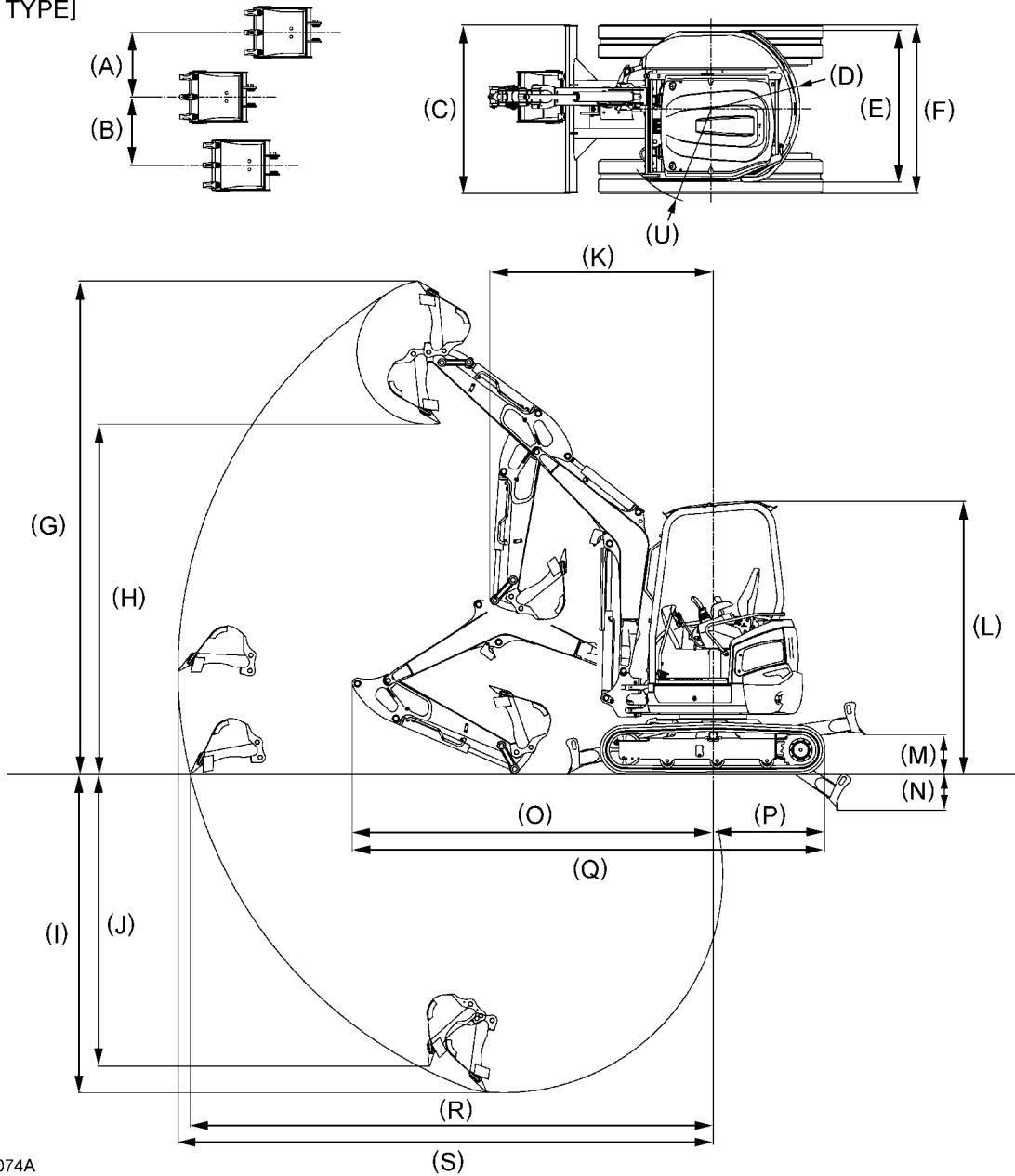

1BAAEAPAP074A

mm (in.)

|                 |                |                |                |               |                 |                |                 |                 |                 |                 |
|-----------------|----------------|----------------|----------------|---------------|-----------------|----------------|-----------------|-----------------|-----------------|-----------------|
|                 | (A)            | (B)            | (C)            | (D)           | (E)             | (F)            | (G)             | (H)             | (I)             | (J)             |
| U27-4<br>CANOPY | 580<br>(22.8)  | 610<br>(24.0)  | 1500<br>(59.1) | 790<br>(31.1) | 1350<br>(53.1)  | 1500<br>(59.1) | 4370<br>(172.0) | 3100<br>(122.0) | 2820<br>(111.0) | 2580<br>(101.6) |
|                 | (K)            | (L)            | (M)            | (N)           | (O)             | (P)            | (Q)             | (R)             | (S)             | (U)             |
| U27-4<br>CANOPY | 1980<br>(78.0) | 2420<br>(95.3) | 350<br>(13.8)  | 320<br>(12.6) | 3200<br>(126.0) | 990<br>(39.0)  | 4190<br>(165.0) | 4630<br>(182.3) | 4740<br>(186.6) | 850<br>(33.5)   |

[CABIN TYPE]

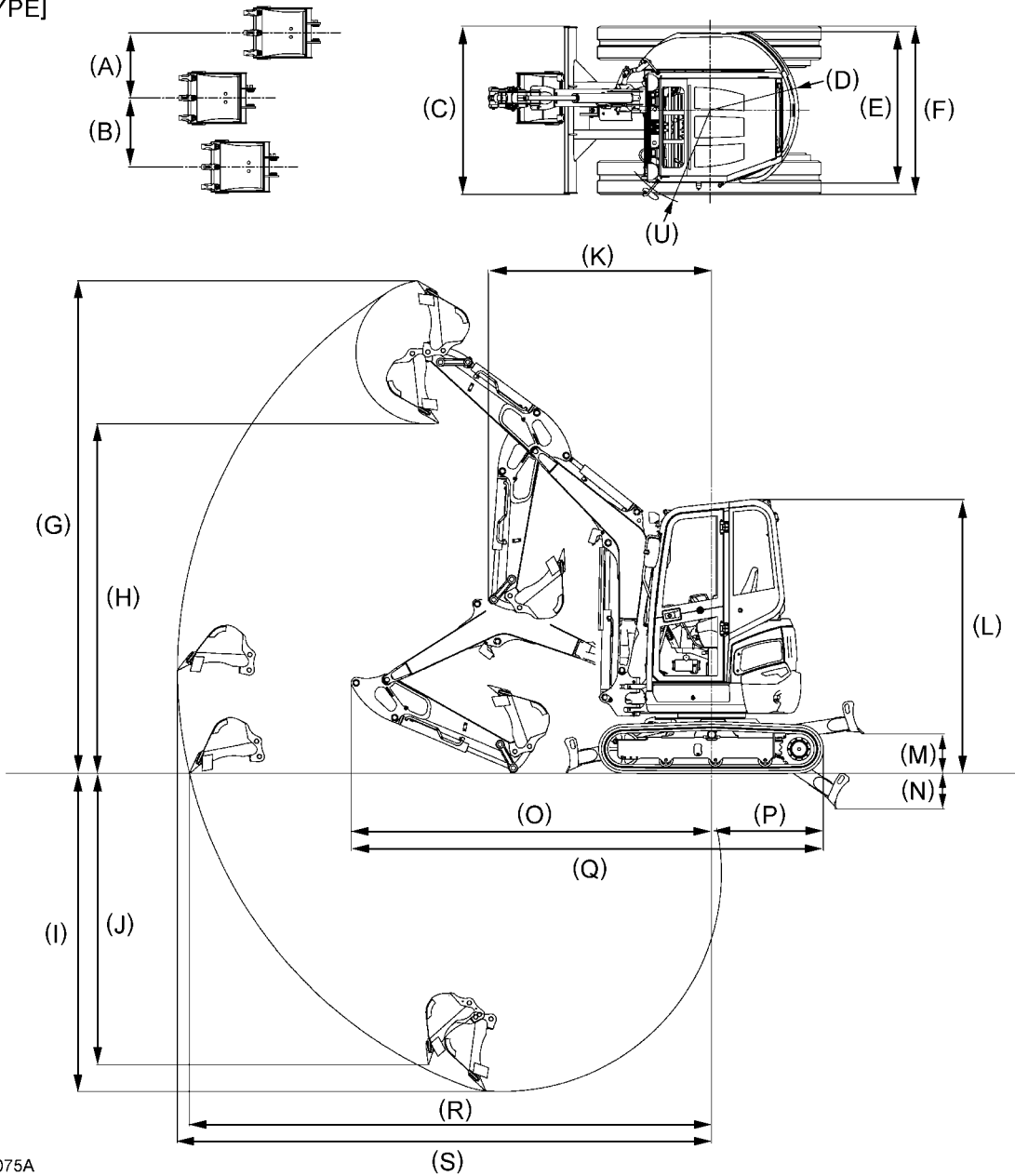

1BAAEAPAP075A

mm (in.)

|             | (A)            | (B)            | (C)            | (D)           | (E)             | (F)            | (G)             | (H)             | (I)             | (J)             |
|-------------|----------------|----------------|----------------|---------------|-----------------|----------------|-----------------|-----------------|-----------------|-----------------|
| U27-4 CABIN | 580<br>(22.8)  | 610<br>(24.0)  | 1500<br>(59.1) | 790<br>(31.1) | 1350<br>(53.1)  | 1500<br>(59.1) | 4370<br>(172.0) | 3100<br>(122.0) | 2820<br>(111.0) | 2580<br>(101.6) |
|             | (K)            | (L)            | (M)            | (N)           | (O)             | (P)            | (Q)             | (R)             | (S)             | (U)             |
| U27-4 CABIN | 1980<br>(78.0) | 2430<br>(95.7) | 350<br>(13.8)  | 320<br>(12.6) | 3200<br>(126.0) | 990<br>(39.0)  | 4190<br>(165.0) | 4630<br>(182.3) | 4740<br>(186.6) | 870<br>(34.3)   |

# LIFTING CAPACITY

- The lifting capacities are based on ISO 10567 and do not exceed 75% of the static tilt load of the machine or 87% of the hydraulic lifting capacity of the machine.
- The strokes are as follows.
  - The load point corresponds to the front bolt part of the arm.
  - The machine positions are over - front (Blade down).
  - The operating cylinder is the boom cylinder.
- The bucket of the excavator, the hook, the sling and other lifting accessories are taken into consideration for the loads.  
Machine conditions:  
No bucket, all others according to the standard regulations.



## WARNING

To avoid personal injury or death:

- No loads greater than those values mentioned in the lifting capacity tables are to be lifted.
- No loads greater than 1 ton are to be lifted when no safety devices are attached to boom and dozer blade cylinders.
- The values mentioned in the table are valid only on even, hard grounds. When lifting on soft ground, the machine can tip over due to the load being concentrated only on one side of the machine.
- The table values are calculated at the end of the arm without the bucket. In order to find the allowable loads for machines with bucket, the bucket weight must be subtracted from the values in the table.

## NOTE :

- In this manual, the machine's lifting capacity is discussed, but it does not mean that it is recommended to use the machine for lifting jobs.
- It is specified in Item 3.4 of ISO 10567:1992 that the following devices must be additionally installed if a hydraulic excavator with the rated lift load of over 1,000 kg at its minimum lifting radius or the tilting moment of over 40,000 N-m is used for lifting loads.
  - (1) Lifting hook
  - (2) Acoustic alarm or warning lamp for the operator when the rated load or the corresponding tilting moment has been exceeded.
  - (3) Boom descending control device conforming to ISO 8643:1997

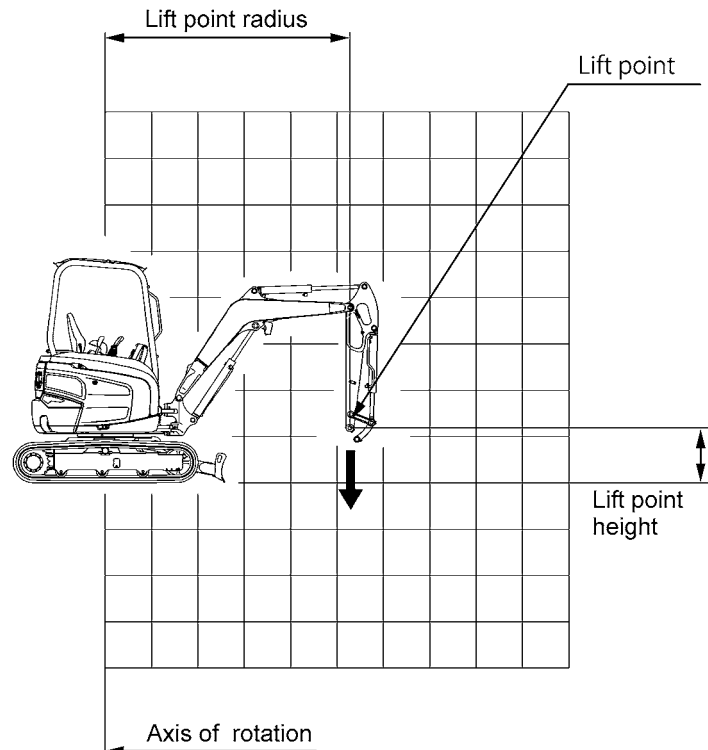

1BAAEAPAP076A

