



SCL 1000

STAND-ON COMPACT LOADER AND ATTACHMENTS

Compact in size, packed with performance and features, Kubota's New Stand-on Compact Loader conquers the toughest of tasks yet is nimble enough to get in tight spaces.



EXCLUSIVE FEATURES



24.8 HP TURBO CHARGED ENGINE

- No DPF
- High altitude performance
- Quiet operation



INTEGRATED TRACK DESIGN

- Robust undercarriage welded to main frame
- Grease track tension design
- Sealed oil bath rollers



NARROW 36" OVERALL WIDTH

- 9.8" wide track standard
- Low 4.0 psi ground pressure
- Outstanding traction force



LCD COLOR DASH MONITORING SYSTEM

- Keyless start with passcode protection
- Easy to read consolidated machine monitoring
- Service interval reminders
- Easy to read in sunlight





POWER & PERFORMANCE

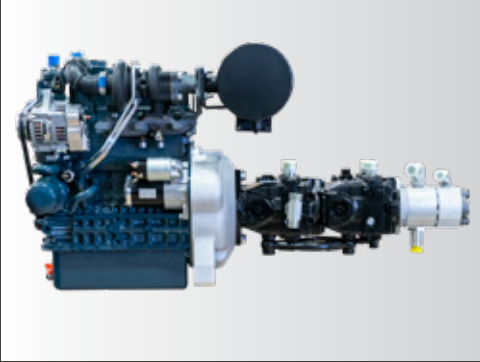

- » 24.8 HP Turbo-charged Kubota engine provides quiet operation, high altitude performance and requires no DPF.
- » Hydraulic pump directly connected to the engine reduces maintenance.



- » Vertical lift loader arms reach higher and further than the competition with a hinge pin height of 84.7" and a reach of 26" (at 45° dump angle).



- » 1000 lbs. ROC combined with 15 gpm auxiliary hydraulic flow make for a powerful and productive compact utility loader.



- » Works in zero clearance yards with low impact wide track design (4.0 psi) minimizing damage to grass or landscaping.
- » 4.9 mph Best in class travel speed

OPERATOR CONTROLS



- » The patent pending T-drive handle provides intuitive and ergonomic steering.
- » Hydraulic pilot-operated loader and drive control valves offer precise and responsive control of the machine.



- » Right hand joystick controls loader arm and bucket movement.
- » Auxiliary hydraulics are easily operated without removing your hand from the loader joystick.
- » Continuous flow in either direction is as simple as pushing a button.

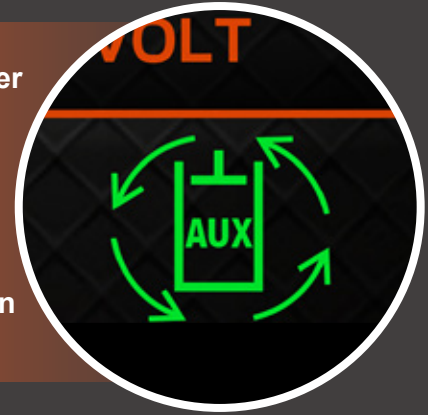

COMFORT & CONVENIENCE



- » Cushioned loader boom cylinders and adjustable platform suspension increase operator comfort for maximum productivity.



- » 4.3" Color LCD monitor
- » Keyless start with passcode protection
- » 12 Volt charging port

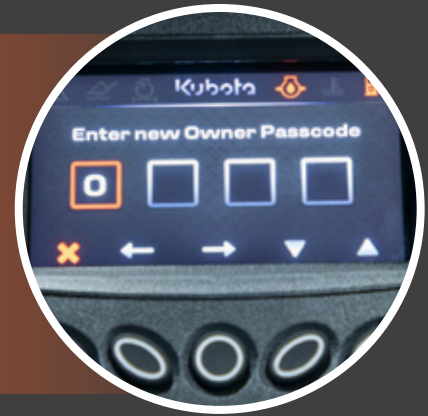



DURABILITY



- » Auxiliary hydraulic lines are routed inside the loader arm for optimal protection. Case drain is standard. Auxiliary hydraulic couplers are pressure release type.
- » Attachment hose guide is standard.



- » Welded track frame has angled top for debris shedding and the dual flange front idler provides better stability and weight distribution.



SAFETY



- » Engine RPM has to be at idle to unlock the hydraulics for machine operation.
- » Walk behind mode for loading onto a trailer allows operation of the travel and loader joysticks only.



- » When operator leaves the platform, the parking brake is automatically engaged.
- » Front LED work light has 30 second courtesy timer to stay on after powering off.



RELIABILITY



- » Heavy-duty cast CII coupler and protective cover for bucket cylinder fittings.
- » CII coupler is standard.
- » Optional welded 2-lever style coupler.



- » Solid state controller minimizes fuses reducing electrical components, while improving reliability.
- » The hood is made out of impact resistant material for greater protection.



SERVICE



- » Easy to access centralized filters and everyday maintenance items.
- » Dash indicator light alerts when the air filter needs cleaned, and service information is readily available at the touch of a button.



- » Maintenance time is reduced with permanently sealed and lubricated track rollers, and the grease type track tension system.



ATTACHMENTS



CL136L, CL142L & CL148H BUCKETS

- CL136L Standard 36" Bucket w/ CII hitch
 - Available w/ bolt-on edge or bolt-on teeth
- CL142L Standard 42" Bucket w/ CII hitch
 - Available w/ bolt-on edge or bolt-on teeth
- CL148H High Capacity 48" Bucket w/ CII hitch
 - Available w/ bolt-on edge or bolt-on teeth



CPF12 COMPACT PALLET FORKS

- 36" & 42" Fork lengths
- 1,200 lb. Capacity

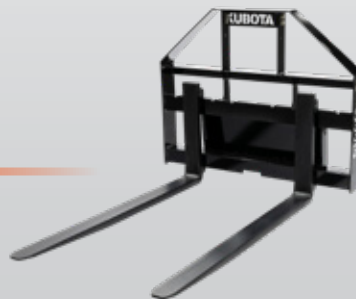

CTR10 COMPACT TRENCHERS

- 30", 36", 48" Trenching depths
- 2 Motors; high speed or high torque
- Positive manual chain tensioner
- Heavy-duty hitch plate
- Chain widths on 30"/36" units: 4", 6", 8" & 10"
- Chain widths on 48" unit: 4" & 6"
- 3 Chain styles



CSA10 COMPACT SKID AUGERS

- 10-20 gpm
- 2" Hex drive
- 6"-24" Dirt augers
- 6" - 12" Rock augers
- Pendulum mount



COMPACT MOUNT FOR KXB BREAKERS

- CII hitch
- Compatible with KXB360QA and KXB460QA Breakers
- Fully welded steel construction



CSR10 COMPACT POWERED RAKE

- 48" Working width
- Heavy-duty hitch
- Proven stud pattern
- Easy, adjustable manual angle
- Hydraulic angling also available
- Center pivot allows narrow width access
- Side plates can angle



SCL1000 STAND-ON COMPACT LOADER

ENGINE	
Engine Type	Water cooled 4 cycle diesel engine with 3 cylinder, turbo, EPA Tier 4
Model Name	KUBOTA D902-T
Total Displacement	54.8 cu.in. (898 cm ³)
Engine Power - SAE J1995 Gross	24.8 HP (18.5 kW/rpm)
Rated Speed	2800 rpm
Low Idling Speed	1250 rpm

DIMENSIONS	
Overall Length - Transport (w/Std Bucket Parallel to Ground)	107.7" (2.74 m)
Overall Length (w/o Bucket)	84.9" (2.16 m)
Overall Height	55.7" (1.41 m)
Overall Width w/Std Bucket	36" (91.44 cm)
Operating Weight (w/o Operator) lbs	3,035 (1,376 kg)
Rated Operating Capacity (35%)	1,000 lb (453 kg) ROC
Tipping Load	2,857 lbs (1296 kg)
Wheelbase	40.5" (1.03 m)
Hinge Pin Height at Max. Lift	84.7" (2.15 m)
Reach at Max. Lift and 45° Dump	26" (66 cm)
Track Width	9.8" (24.9 cm)
Ground Clearance	7.4" (18.8 cm)
Angle of Departure	25.2°

PERFORMANCE	
Attachment Mounting System	CII (Common Industry Interface) or 2 Lever Quick-Attach
Travel Speed (Fwd/Rev)	4.9 mph (7.9 km/h)
Ground Pressure (with Operator)	4.0 psi, 28.0 kPa (0.28 kgf/cm ²)
Battery Capacity	12V, RC 80, 540 CCA
Auxiliary Hydraulic Flow	15 gal/min (56.7812 L/min)
Auxiliary Hydraulic Pressure	2800 psi (19.3 mPa) (196.8 kgf/cm ²)

SERVICE & FILL CAPACITIES	
Fuel Tank Capacity	7.75 gal (29.3 L)
Hydraulic System	6 gal (22.7 L)

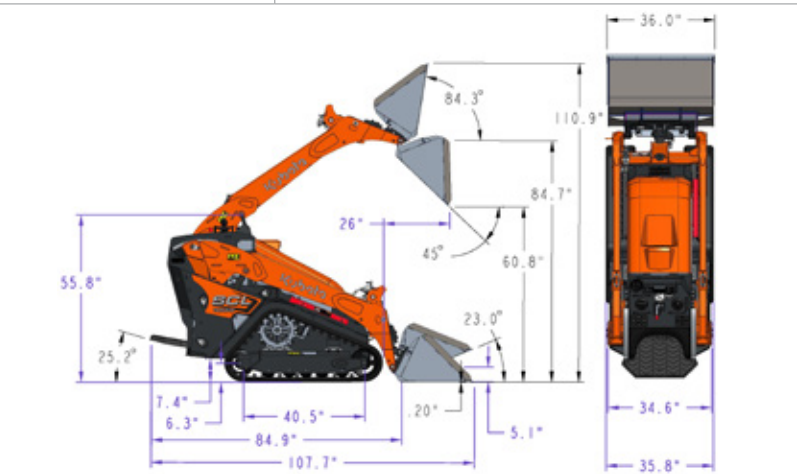

kubota.ca

© 2021 Kubota Canada LTD

Head Office: 1155 Kubota Drive, Pickering, Ontario L1X 0H4 TEL: (905) 294-7477

Kubota Canada Ltd reserves the right to change the stated specifications without notice. The comparisons are for descriptive purposes only and does not provide any express or implied warranty of any nature, including any warranty of merchantability or for a particular purpose. For complete operational information, the operator's manual should be consulted. Kubota Canada Ltd supplies products and services to Canadian residents only. For information regarding Kubota products or services outside of Canada, see Kubota Corporation's global website. 1/1/22 Part # SCL-22-EN