

RA1042T

Operator's manual
Original operator's manual

Edition	09.2013
Date of print	09.2014
Language	EN-EU
Machine number	VF65982451 –
Model	VF6598
Document number	VF16660942.EN-EU

Machine identification

In order for your dealer to assist you as efficiently as possible, you will need to provide some information about your machine. Please enter the details here.

Designation	RA1042T
Working width	4.20 m
Weight	570 kg
Machine number	VF6598_ _ _ _ _
Accessories	
Supplier's address	
Manufacturer's address	Kverneland Group Kerteminde AS Taarpstrandvej 25 DK-5300 Kerteminde Denmark Tel: +45 65 19 19 00

Table of contents

Preface	4	Cleaning and care	56
Target group for this operating manual	4	Safety	56
Symbols used	5	Cleaning	57
Safety	6	Care	57
For your safety	6	Parking and storage	58
Who is allowed to operate the machine?	10	Safety	58
General	10	General	58
safety information	10	Uncoupling the machine	59
Coupling	13	After the end of the season	60
Hydraulics	13	Maintenance	61
Road transport	14	Safety	61
Operation	16	General	63
Uncoupling	17	Screwed connections	65
Care and maintenance	18	Lubrication points for grease	67
Further regulations	19	Lubricating the PTO shafts	68
Familiarising yourself with the machine	20	Filling quantities	69
Range of application	20	Tyres	69
Features	20	Hydraulics	70
Designation of components	21	Additional equipment	71
Technical specifications	22	Optional accessories	71
Delivery and assembly	26	Fault elimination	74
Checking the scope of delivery	26	Faults	74
Length of PTO shaft	27	Circuit diagrams	75
Coupling the machine	29	Hydraulic system connection diagram	75
Safety	29	Lighting equipment circuit diagram	76
General	29	Decommissioning	77
Coupling the machine	30	Environment	77
Connecting the electrics [+]	34	EC Declaration of Conformity	78
Connecting the hydraulics	37	Conforms to	
Preparing for use	38	EC Directive	
Safety	38	2006/42/EC	78
General	38	Index	80
Rotor pitch	39		
Working depth	40		
Road transport	42		
Safety	42		
General	43		
Prior to road transport	43		
Road transport	47		
Preparations on the field	48		
Safety	48		
General	48		
Basic settings	49		
Operation	52		
Safety	52		
General	53		
Swathing	54		
Swath deposit	55		
Driving on headlands	55		



Target group for this operating manual

This operating manual is intended for trained agriculturists and persons who are otherwise qualified for agricultural activities and have received instruction in working with this machine.

Minimum age

Children under the age of 16 are not permitted to operate the machine.

For your safety

You must familiarise yourself with the contents of this operating manual before assembly or initial operation of the machine. In this way, you will achieve optimum work results and operational safety. The operating manual forms an integral part of the machine and must always be kept to hand. This will ensure that you:

- avoid accidents.
- comply with warranty conditions.
- have a fully functional machine in good working order at all times.

Training

You will receive training from your dealer concerning using the controls and care of the machine.

Information for the employer

All personnel are to be regularly, but at least once a year, instructed on the use of the machine, in accordance with the regulations of the national organisation for Health and Safety at Work. Untrained or unauthorised persons are not permitted to use the machine.

You are responsible for ensuring that the machine is operated and maintained safely. Make sure that you and all other persons that operate, maintain or work in close proximity with the machine are familiar with the operating and maintenance regulations, as well as the corresponding safety instructions in this operating manual.



Symbols used

In this operating manual, the following symbols and terms have been used:

- A bullet point accompanies each item in a list.
- ▶ A triangle indicates operating functions which must be performed.

→ An arrow indicates a cross-reference to other sections of this manual.

[+] A plus sign indicates additional equipment which is not included in the standard version.

We have also used pictograms to help you find instructions more quickly:



The "Information" pictogram indicates tips and additional information.



The "Examples" pictogram indicates examples that assist understanding of the instructions.



Caution

The warning triangle indicates important safety information. Failure to observe this safety information can result in:

- Serious faults in the correct operation of the implement.
- Damage to the machine.
- Personal injury or accidents.



The spanner indicates tips for assembly or adjustment work.



Switch on the tractor.



Switch off the tractor and secure it against rolling away.



The arrow in the diagram shows the direction of travel.



For your safety

This chapter contains general safety instructions. Each chapter of the operating manual contains additional specific safety information which is not described here. Observe the safety information:

- in the interest of your own safety.
- in the interest of the safety of others.
- to ensure the safety of the machine.

Numerous risks can result from handling agricultural machinery in the wrong way. Therefore, always work with particular care and never under time pressure.

Information for the employer

Inform all persons who work with the machine about this safety information at regular intervals and in accordance with statutory regulations.



Warning signs

Safety-related stickers attached to the machine indicate potential hazards. The stickers must not be removed. Illegible or missing stickers should be replaced. You can obtain new stickers as replacement parts from your dealer.

Warning signs on the machine

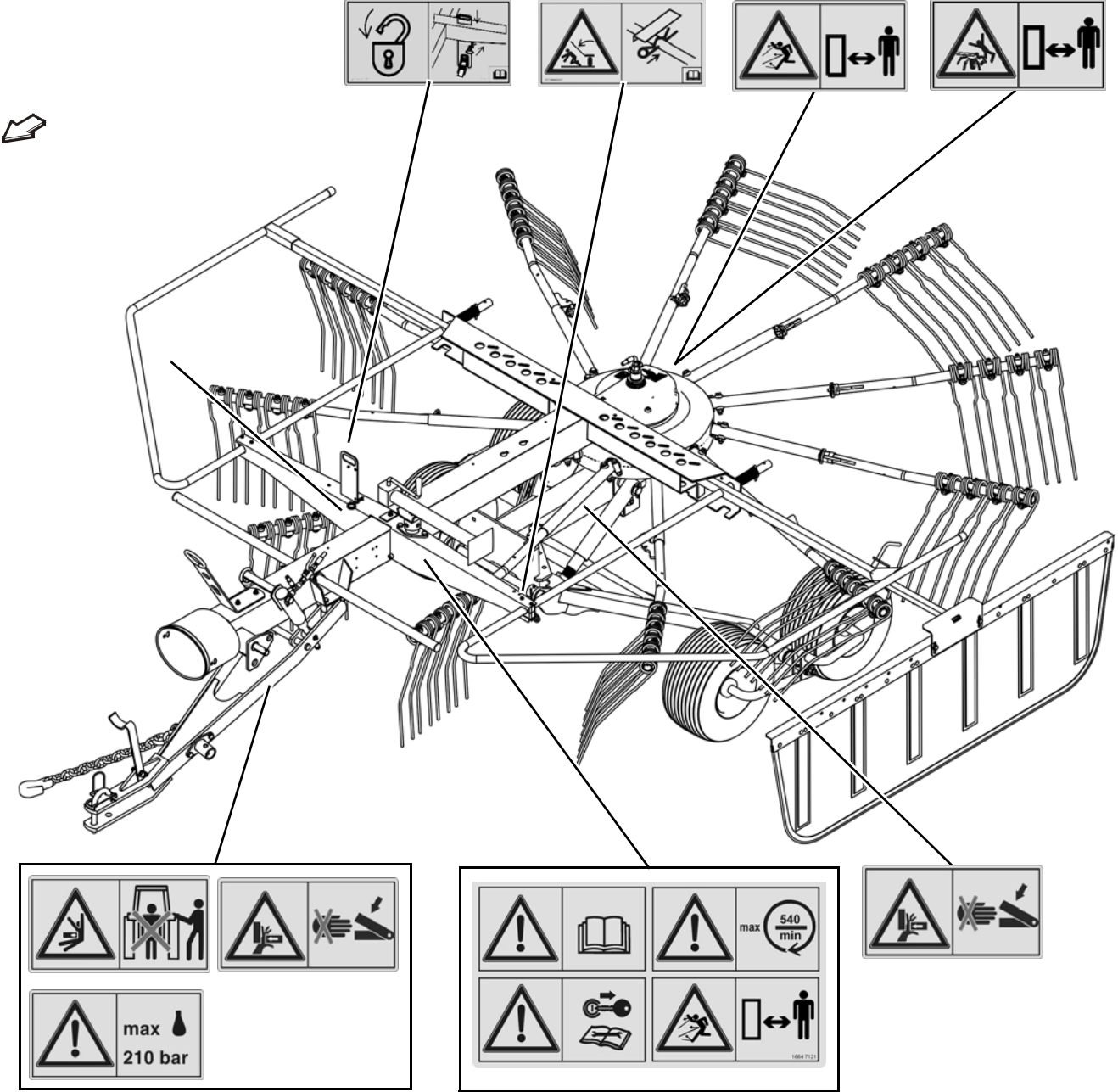



Meaning of warning signs



Read the operating manual

Read and follow the operating and safety instructions before using the machine for the first time. The machine must not be used for the first time until the operating manual has been read and understood. This applies in particular to the safety information. Otherwise, serious or fatal injury may be caused as a result.



Switch off the engine

Only perform maintenance, repair and adjustment work when the machine is shut down. Otherwise, serious or fatal injury may be caused as a result.



Distance from the rotor

Maintain a safe distance from the rotor when it is rotating. Nobody may remain in close proximity to the machine when tedders and rakes are running. Otherwise, serious or fatal injury may be caused as a result.



Distance from the tractor

When the machine is being coupled, uncoupled or operated, there should be no-one between the tractor and the machine. Otherwise, serious or fatal injury may be caused as a result.



Risk of crushing

Never reach into an area where there is a risk of crushing if parts in that area are still likely to move. Otherwise, serious or fatal injury may be caused as a result.



Caution, parts ejected at speed

Hazard caused by parts which may become detached when the drive is in operation, and ejected at speed. Maintain a safe distance. Otherwise, serious or fatal injury may be caused as a result.



Secure the swath former after it is folded up

Secure the swath former after it is folded up. The swath former may fold down unexpectedly. Otherwise, serious or fatal injury may be caused as a result.



Securing the rotors

Secure the rotor in the transport position. The rotor may turn unexpectedly due to centrifugal forces. Otherwise, serious or fatal injury may be caused as a result.



PTO shaft speed 540 rpm

The specified maximum PTO shaft speed of 540 rpm must not be exceeded. Otherwise, damage to the machine may be caused as a result.



Do not exceed the maximum hydraulic pressure

The tractor's hydraulic pressure on the machine's hydraulic system must not exceed 210 bar. Otherwise, damage to the machine may be caused as a result.



Who is allowed to operate the machine?

Only qualified persons may operate the machine

Only qualified persons who have been informed of the dangers associated with handling the machine are permitted to operate, service or repair the machine. The necessary knowledge can be gained in the course of agricultural vocational training, professional training or intensive instruction.

General safety information

The general safety information and warning signs apply to every phase of the life cycle of the machine and to every application.



Switch off the tractor and secure it

Before you dismount:

- ▶ Switch off the tractor.
- ▶ Remove the ignition key.
- ▶ Secure the tractor against rolling away.

An unsecured tractor can run you over or trap you. Otherwise, serious or fatal injury may be caused as a result.

Operate for the first time only after proper training

The machine may only be put into operation after proper training has been provided by an employee from a dealership or the manufacturer, or by a factory representative. Operation without proper training can lead to damage to the machine due to incorrect operation, or may cause accidents.

Safety is your responsibility

Follow the safety instructions. Ensure that all operators comply with the safety instructions. Prevent serious or fatal accidents by following the safety instructions.

Instructions in the event of malfunctions

In the event of a malfunction, shut down, stop and secure the machine immediately. Rectify the malfunction immediately yourself or seek the assistance of a workshop. Operating a faulty machine can cause accidents or damage.

No persons in the working area

Ensure that no persons are present in the slewing and working area of the machine. Persons could be caught by the machine within this area. This could result in fatal injury.

Perfect working condition

Ensure that the tractor and the machine are always in perfect working condition. Make sure that the tractor brakes work in synchronisation with the machine. Also follow the instructions in your tractor's operating manual.

**Switch off the tractor PTO shaft drive**

Switch off the tractor's PTO shaft drive when changing from work to transport position (and vice versa). Wait for moving parts to come to a stop. If this requirement is ignored, the consequence may be damage to the machine and even life-threatening injuries.

No reversing while the drive is running

Never drive in reverse with the PTO shaft drive switched on and in the work position if people could enter the working area of the machine. Switch off the PTO shaft drive. Rotating, unprotected parts can damage the machine and cause life-threatening injuries.

Specified workwear

Do not wear loose fitting clothing. Loose fitting items of clothing may become caught in rotating parts. Wear workwear and protective clothing, as specified by the Accident Prevention and Insurance Association. Serious or fatal injury may be caused as a result.

No riding on the machine

Persons or objects must never be transported on the machine. Carrying passengers on the machine is life-threatening and prohibited. Serious or fatal injury may be caused as a result.



Never work on the machine while it is running

No operations may be performed on the machine while it is running. Objects or persons can be caught, drawn in or crushed. Serious or fatal injury may be caused as a result.

PTO shaft

Use only the PTO shafts specified by the manufacturer and read the attached operating manual carefully. Adjust the length of the PTO shaft as required. Incorrect PTO shaft lengths can cause damage to the machine and personal injury.

Check and fasten the PTO shaft guard in position

The rotating PTO shaft is protected by the PTO shaft guard. Ensure that the guard is not damaged. Fasten the PTO shaft guard in position by connecting the chains on the implement and the tractor. Unguarded PTO shafts can cause life-threatening injuries.

Make sure the machine is standing level

Before changing from the transport to the work position (and vice versa), make sure the machine is standing level. Otherwise, damage to the machine and serious or fatal injury may be caused as a result.

Do not make any modifications to the machine

No modifications of any kind may be made to the machine. Unauthorised modifications can adversely affect the correct operation and safety of the machine and shorten its service life. Unauthorised modifications to the machine render the manufacturer's guarantee null and void and free the manufacturer from all liability.

PTO shaft speed 540 rpm

The specified maximum PTO shaft speed of 540 rpm must not be exceeded. A higher PTO shaft speed will damage the machine.

Unrestricted field of vision to the rear

After it has been coupled, ensure that you have an unrestricted view of the machine, in both its work and transport positions. At the very least, use the panorama mirror provided by the tractor manufacturer. Otherwise, dangerous situations may not be detected in time, resulting in accidents or damage.



Coupling

Increased risk of injury

When the machine is being coupled to the tractor, there is an increased risk of injury. Therefore:



- Secure the tractor against rolling away, shut off the engine and remove the ignition key.
- Never stand between the tractor and machine.
- Lock the PTO shaft securely on the PTO stub shafts of the tractor and the machine.

If this requirement is ignored, the consequence may be damage to the machine and even life-threatening injuries.

Attaching electrical connections after assembly

The electrical supply to the tractor must not be connected when the lighting equipment is being fitted. Otherwise, short circuits will occur and the electronic system will be damaged.

Observe the operating manual of the PTO shaft manufacturer

Observe the operating manual of the PTO shaft manufacturer. It will provide you with instructions on how to handle the PTO shaft correctly. If these instructions are ignored, damage may be caused to the PTO shaft and machine.

Hydraulics

Hydraulic connection at zero pressure only

Only connect hydraulic hoses to the tractor hydraulic system if the tractor and machine hydraulic system is at zero pressure. A pressurised hydraulic system can trigger unpredictable movements of the machine and can cause serious damage to the machine and personal injury. Serious or fatal injury may be caused as a result.

High pressures in the hydraulic system

The hydraulic system is under high pressure. Regularly check all lines, hoses, and screwed connections for leaks and externally visible damage. Only use suitable equipment when looking for leaks. Rectify any damage immediately. Oil escaping under pressure may result in injuries and fires. Seek medical attention immediately if injuries occur.

Replace hydraulic hoses every six years

Hydraulic hoses age without showing externally visible signs. Replace hydraulic hoses every six years. Defective hydraulic lines can cause serious or fatal injuries.



Road transport

Ensuring road safety

The machine must conform to current national traffic regulations if you intend to drive with it on public roads. Ensure the following:

- Lighting, warning and protective equipment must be fitted.
- The permissible transport widths and weights, axle loads, tyre load-bearing capacities, laden weights and national speed restrictions must be complied with.
- The maximum permissible road transport speed must be complied with, but not exceed 50 km/h.
- Before driving on public roads, fully fold in all guard bars and secure the machine. All tine supports which have tips that point at right angles to the direction of travel must be removed.
- The machine should only be towed by agricultural or forestry tractors.

The empty weight of the tractor must be greater than the weight of the machine. The driver and keeper of the vehicle are liable should these conditions not be observed.



Close the ball valve

Close the ball valve before driving on the road. If the ball valve is open and there is an operating error, the machine may drop or swing out unexpectedly. This could cause traffic accidents and accidents with fatal consequences.

Check tyre pressures

Check tyre pressure on a regular basis. Incorrect tyre pressures reduce the service life of a tyre and cause unstable driving characteristics. Accidents with serious or fatal injuries may be caused as a result.

Altered driving and braking performance

Driving and braking performance are altered when the machine is coupled or hitched to the tractor. When cornering, take the overall width and balancing weight of the machine into consideration. Adjust your driving speed accordingly. A driving style which is not adapted to conditions can cause accidents. Accidents with serious or fatal injuries may be caused as a result.

Speed adjustment

In poor road conditions and at high speeds, significant forces can be generated which subject the tractor and machine material to high or excessive stresses. Adjust your driving speed to the road conditions. A driving style which is not adapted to conditions can cause accidents. Accidents with serious or fatal injuries may be caused as a result.

Check hitch pins

Hitch pins must be in perfect condition. Hitch pins must show no signs of wear and be properly secured. Otherwise, hitched machines may detach themselves of their own accord. Accidents with serious or fatal injuries may be caused as a result.

Operation

Operate for the first time only after proper training

The machine may only be put into operation after proper training has been provided by an employee from a dealership or the manufacturer, or by a factory representative. Operation without training can lead to damage to the machine due to incorrect operation, or cause accidents.

Ensure that the machine is in perfect working condition

Do not operate the machine unless it is in perfect working condition. Check all key components and their correct operation before use. Replace defective components. Defective components can cause material damage and personal injury.

Check the protective equipment

The protective equipment must not be removed or by-passed. Check all protective equipment before using the machine. Unprotected machine parts can cause serious or fatal injury.

Check the immediate vicinity

Check the area immediately surrounding the machine before driving off, and continually during operation. Make sure that you have an adequate view. Only begin work when the immediate vicinity is cleared of any persons or objects. Serious or fatal injury may be caused as a result.

Retighten all nuts, bolts and screws

Regularly check that nuts and bolts are correctly tightened. Retighten bolts if necessary. Nuts and bolts can work loose when the machine is used. Damage to the machine or accidents may be caused as a result.

The PTO stub shaft continues turning after it has been switched off

After the PTO stub shaft drive on the tractor has been switched off, the machine continues to run due to the moment of inertia. Maintain a sufficiently safe distance until all moving parts have come to a complete standstill. Otherwise, damage to the machine and serious or fatal injury may be caused as a result.

Cornering and turning manoeuvres

Centrifugal forces are in operation during cornering. The machine's centre of gravity at the rear of the tractor is displaced. Be aware of the turning radius and the moment of inertia. A driving style which is not adapted to conditions can cause accidents. Accidents with serious or fatal injuries may be caused as a result.

Uncoupling

Increased risk of injury

There is an increased risk of injury when uncoupling the machine from the tractor. Therefore:



- Secure the tractor against rolling away, turn off the engine and remove the ignition key.
- Never stand between the tractor and machine.
- Set the machine down on firm, secure and level ground.
- Ensure that the parking stand is securely locked.
- Place the PTO shaft in the holder provided.
- Secure the machine against rolling away (use wheel chocks).
- Do not disconnect hydraulic hoses until there is no pressure in the tractor and machine hydraulic system.

Failure to observe these instructions can result in serious or fatal injury.

Care and maintenance

Observe the care and maintenance intervals

Observe the periods specified in the operating manual for recurrent checks and inspections. If these periods are not observed, damage to the machine and accidents may be caused as a result.

Use original parts

Many components have special properties that are essential for the stability and correct operation of the machine. Only spare parts and accessories supplied by the manufacturer have been tested and approved. Other products may adversely affect the correct operation of the machine and safety. Using non-OEM replacement parts renders the manufacturer's guarantee null and void and frees the manufacturer from all liability.

When performing care and maintenance work:



- Switch off the PTO shaft drive.
- Depressurise the hydraulic system.
- Whenever possible, uncouple the tractor.
- Switch off the tractor and remove the ignition key.
- Ensure the machine is standing on firm, secure and level ground, and provide additional support, if necessary.
- Secure the machine against rolling away (use wheel chocks).

Only if these regulations are observed can safe working be ensured during care and maintenance work.

Turn off the electrical supply

Prior to carrying out work on the electrical system, disconnect the system from the power supply. Systems being supplied with electrical power can cause damage to equipment and injury to persons.

Caution when cleaning with a high-pressure cleaner

Exercise caution when cleaning with a high-pressure cleaner. Bearings, seals and pipe unions are not waterproof. In order to prevent damage to the machine, the bearings, seals and pipe unions must not be exposed to direct contact with the high-pressure water jet.

No aggressive washing additives

Do not use any aggressive washing additives for cleaning. Uncoated metal surfaces can be damaged.

Before carrying out welding work

Disconnect all electrical connections from the tractor when carrying out welding on the hitched machine. Damage may otherwise be caused to the electrical system.

Retighten all nuts, bolts and screws

All pin and screwed connections that are loosened during maintenance and repair operations must be retightened. Serious injury and damage to equipment can be caused by loose pin and screwed connections.

Further regulations

Observe the regulations

In addition to the safety information listed above, please observe the following:

- Accident prevention regulations.
- Generally recognised safety regulations, occupational health requirements and road traffic regulations.
- The instructions provided in this operating manual.
- Regulations relating to operation, maintenance and repair.

Warranty

The warranty and manufacturer's liability will no longer be valid if the instructions provided in the chapter on Safety are not observed, if maintenance is inadequate or faulty, if the machine is used for purposes other than those for which it was intended and if it is overstressed, or if impermissible modifications are made to the machine.

Familiarising yourself with the machine

Range of application

This product is classified as replaceable equipment in accordance with EC directive 2006/42/EC.

The machine is a single-wheel rake, which is suitable only for the raking together of mown, stalked material (for example, hay or straw).

Proper use

Any use other than the use described above - such as silo spreading, any type of soil preparation, sweeping, or transmitting power to other machines - is not permitted. The manufacturer and dealers are not liable for damage caused by improper use. The risk is borne solely by the user.

Features

Flexible in operation

This single-wheel rake meets all the requirements of modern crop harvesting engineering. Important functions for field use are controlled during active operation.

The rake can be pulled by tractors of 15 kW (20 hp) or more.

Extensive equipment

The machine is equipped with a low-maintenance gear box and 11 tine supports on each rotor. The cranked tines achieve an excellent raking quality.

Easy changeover from work to transport position

The rake is easily changed over from the work to the transport position.

Raise height of 50 centimetres

For road transport and on headlands, the machine can be quickly raised by roughly 50 centimetres. For working, lower the rotary rakes hydraulically from transport position back to work position.

Familiarising yourself with the machine

Designation of components

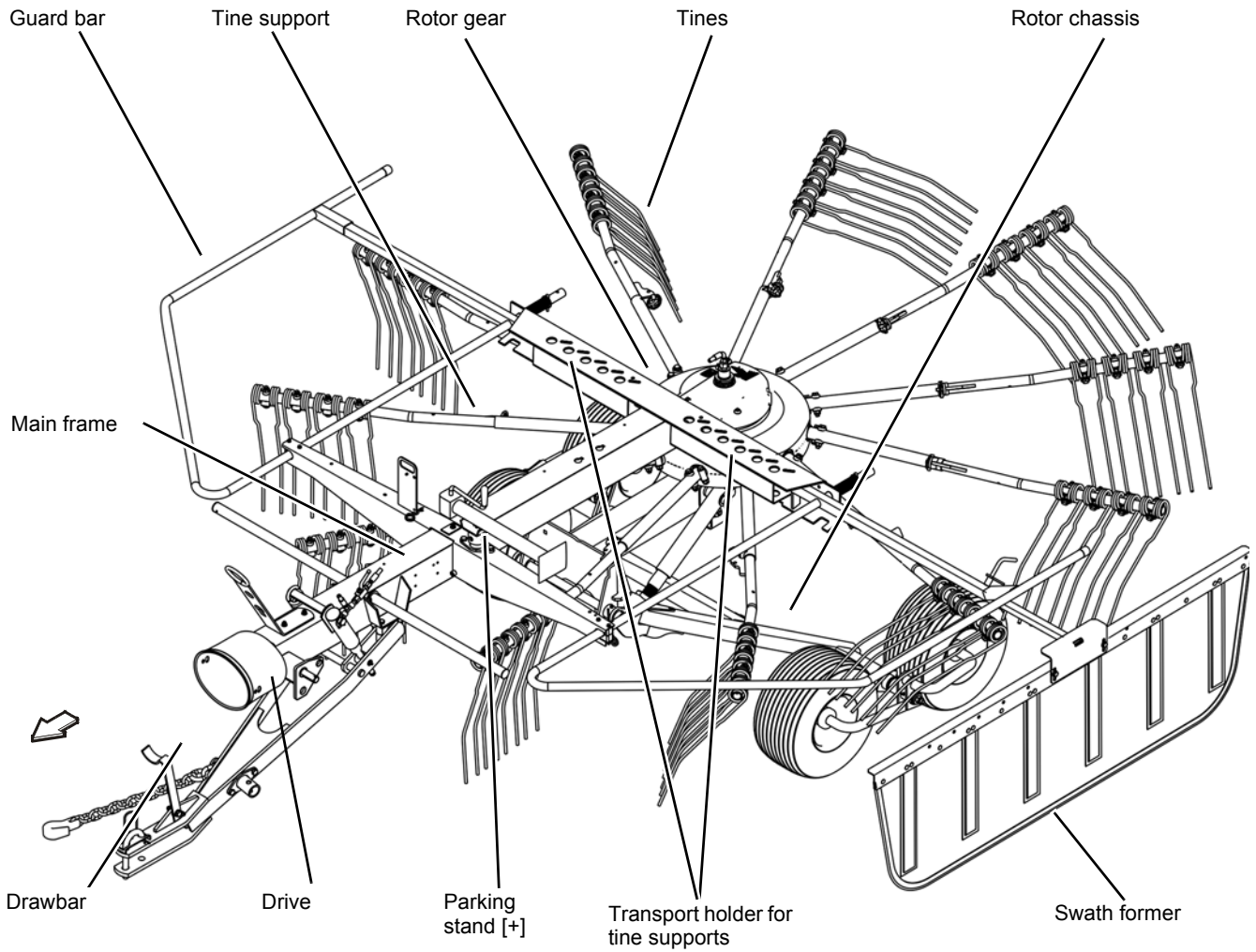

Familiarising yourself with the machine

Technical specifications

Dimensions in transport position

		[m]
L_R	Length in transport position for road transport	4.00
H_R	Height in transport position for road transport	2.30
W_R	Width in transport position for road transport	2.00* (2.45)
W_T	Width in transport position from tyre to tyre	2.00
T	Track width	1.60
O	Height of top reflectors	1.25
P	Distance between top reflectors	1.70
R	Height of bottom reflectors	0.40
S	Distance between bottom reflectors	0.65

* Swath former in transport position

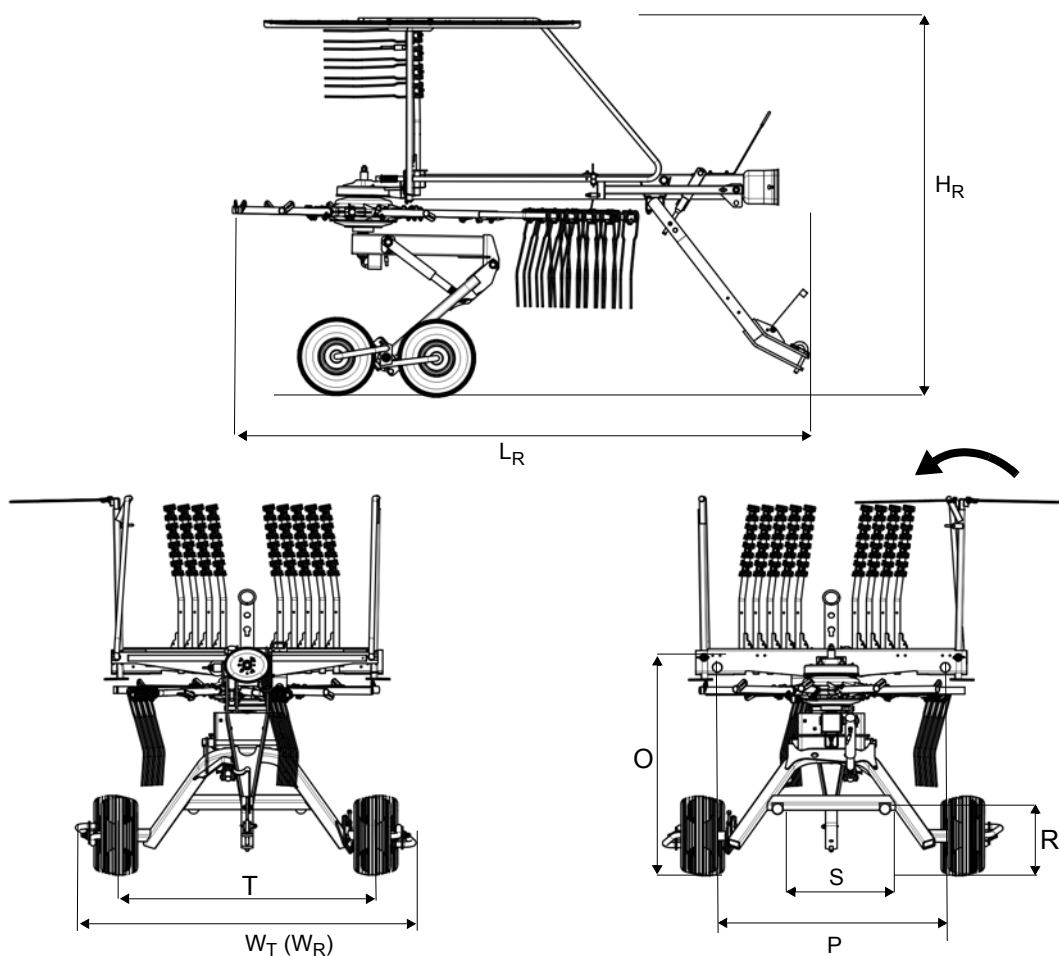

Familiarising yourself with the machine

Dimensions in work position

		[m]
L_W	Length in work position	4.75
H_W	Height in work position	1.25
RD	Rotor diameter	3.35
SE	Width with swath former fully extended	4.20

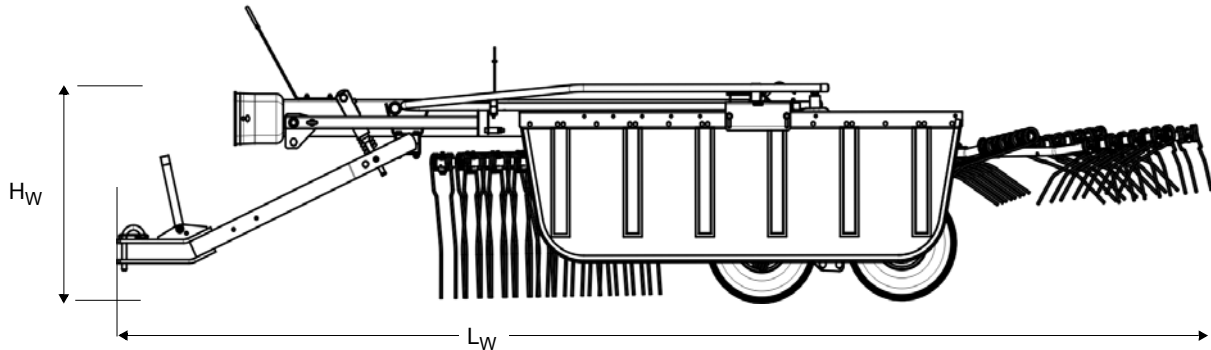
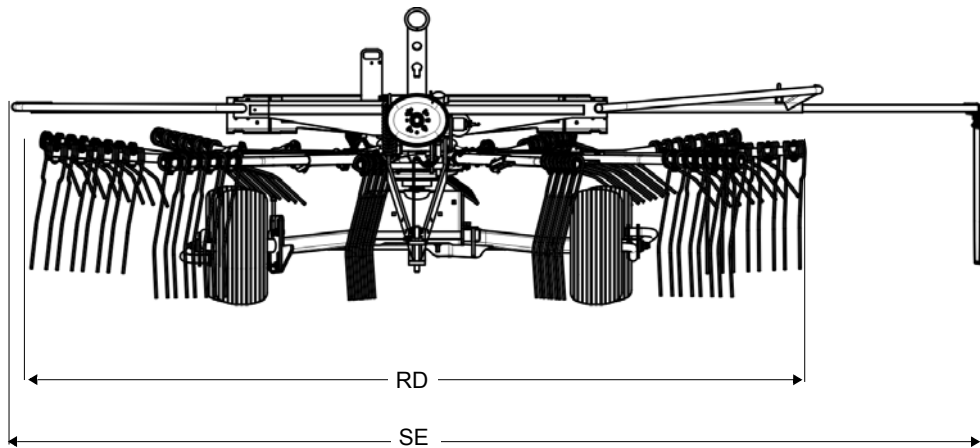

Familiarising yourself with the machine

Weights

Total weight	570 kg
Load supported on parking stand	150 kg

Tractor equipment required

Output / connections		
	Minimum output of the tractor	15 kW (20 hp)
	Lighting equipment power supply	12 V, 7-pin plug socket ISO 1724
	Hydraulic connections	1 x single-acting hydraulic control device
	Hydraulic pressure	150 - 210 bar
	Maximum PTO shaft speed	540 rpm
	Pending attachment	In accordance with ISO 6489-3
	Alternatively: lower link and lift link drawbar	Fixable in height and laterally

Familiarising yourself with the machine

Machine equipment

Swath deposit		
	Swath former	Standard
Rotors / tine supports / tines		
	Number of rotors	1
	Number of tine supports per rotor	11
	Number of tines per tine support	4
	Removable tine arms	Standard
	Rotor height adjustment	Hydraulic/mechanical
	Tine saver	[+]
Wheels		
	Rotor chassis with tandem axle	18 x 8.50-8 PR 6
Safety accessories		
	Safety chain	Standard
	Lighting equipment	[+]
	Warning signs	[+]
PTO shaft		
	PTO shaft (wide-angle, double-ended)	Standard

Measurement of airborne sound emissions

The airborne sound emissions from the machine are below the levels stipulated by machinery directive 2006/42/EC.

- A-weighted sound level in the workplace:
< 70 dB(A)
- Currently C-weighted sound level:
< 63 Pa (130 dB based on 20 µPa)
- A-weighted sound level on the machine:
< 80 dB(A)

Delivery and assembly

Checking the scope of delivery

Delivery is in the fully assembled state

The machine is delivered fully assembled. Using the check list, check the loose parts on delivery. If any parts of the machine have not been fitted or are missing, please contact your dealer.



Do not assemble the machine yourself

Trained personnel are required to assemble the machine. Do not perform assembly work yourself. The following points are required to be met for the machine to be in proper condition:

- Observance of a sequence of worksteps.
- Compliance with tolerances and torques.
- Knowledge of work safety during assembly.

Incorrect assembly can result in damage to the machine or accidents.



If parts are missing or have been damaged during transportation, please inform the dealer, importer or manufacturer immediately.

Check list for parts which were supplied loose	Quantity
PTO shaft for drive	1
Tine support placing swaths on the left	11
Swath former	1
Operating manual	1
Spare part manual	1
Additional equipment	See delivery note

Length of PTO shaft

The length of the PTO shaft was selected at the factory to suit almost all types of tractor. Only in exceptional cases is a correction of the PTO shaft length required on individual tractors. Check the length of the PTO shaft on each tractor prior to first use.

A manufacturer's operating manual for the PTO shaft is enclosed. This includes detailed information on the relevant version of the PTO shaft and must be observed.

Safety



Switch off the tractor and secure it

Before you dismount:

- ▶ Switch off the tractor.
- ▶ Remove the ignition key.
- ▶ Secure the tractor against rolling away.

**An unsecured tractor can run you over or trap you.
Otherwise, serious or fatal injury may be caused as a result.**

Checking the angle of lock

The PTO shaft has a wide hinge joint giving the tractor a steering angle of up to 80°. Make sure that the PTO shaft is not damaged during sharp cornering. This would result in damage to the machine.

Correct length

A PTO shaft that is too long must not be used. This would result in damage to the drive bearings of the tractor and the machine.

Delivery and assembly

Checking the length of the PTO shaft

- ▶ Couple the machine to the tractor without the PTO shaft.
- ▶ Lower the lower link of the tractor.
- ▶ Set the combination (tractor and machine) to the smallest steering angle.
- ▶ Switch off the tractor and secure it against rolling away.



Shortening the PTO shaft

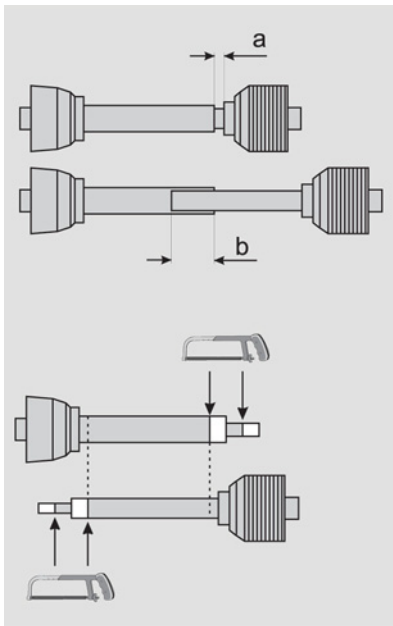

- ▶ Pull the PTO shaft apart and connect one half to the tractor PTO shaft drive and one to the machine and secure them.
- ▶ Place the two shaft halves next to each other and:
 - Check for a minimum of 200 mm overlap (b).
 - Check that the PTO shaft is not blocked at one end (minimum distance (a) = 20 mm).
- ▶ Shorten the slide tube and guard tube by the same dimension.
- ▶ Deburr the ends of the tube.
- ▶ Remove the swarf.
- ▶ Grease the sliding surfaces well.

Fitting the PTO shaft

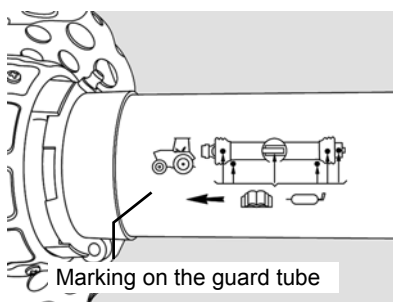

Make sure that you fit the PTO shaft in the correct installation position. There is a marking on the guard tube of the PTO shaft.

- ▶ Check the length of the PTO shaft and shorten it if necessary.
- ▶ Place the PTO shaft onto the PTO stub shaft of the machine.
- ▶ Secure the PTO shaft with a locking pin.

Safety



Observe the safety information

Observe the safety information. Disregard for safety information can lead to serious or fatal injury. See chapter »Safety«, page 6.

Increased risk of injury

When the machine is being coupled to the tractor, there is an increased risk of injury. Therefore:

- Never stand between the tractor and machine.
- Secure the tractor against rolling away.
- Actuate the three-point power lift system slowly and carefully.

Failure to observe these instructions can result in serious or fatal injury.

General

The machine is equipped at the factory for coupling to the pending attachment or a lift link drawbar.

The following worksteps are described in this section:

- »Coupling the machine«
- »Coupling the PTO shaft«
- »Connecting the electrics [+]
«
- »Connecting the hydraulics«

Coupling the machine

Coupling the machine

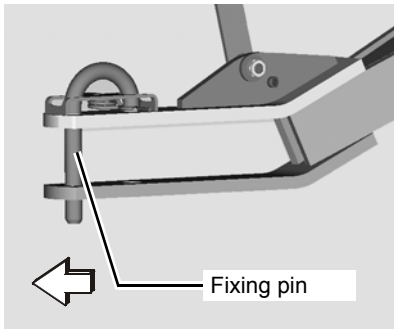

Genuine fixing pins from the manufacturer

Use only genuine fixing pins from the manufacturer. These have the required strength. Other pins can break. Damage to the machine or accidents may be caused as a result.

The rotary rake is coupled to the pending attachment or a lift link drawbar with a fixing pin and secured with a safety splint.

→ See »Coupling to the pending attachment«, page 31.

– or –

→ See »Coupling to the lift link drawbar«, page 32.



A freely turnable lift link drawbar is available as an optional accessory for coupling to lower links of category I-II.

→ See »Lift link drawbar [+]<«, page 71.

Safety chain for USA and Canada

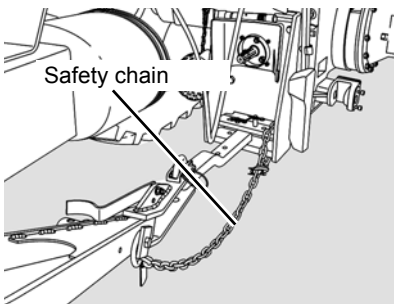

In the USA and Canada, it is obligatory to secure the rotary rake to the tractor with a safety chain.



Observe national regulations concerning the length and fitting of the safety chain.

Coupling to the pending attachment

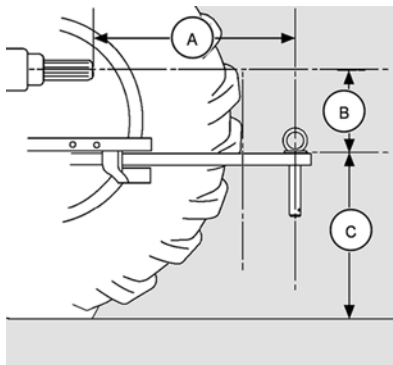

Lock the height adjustment of the lower link

Lock the height adjustment of the lower link. Comply with the tractor operating manual. Unintentionally raising the lower links can irreparably damage the PTO shaft.

Lock the lateral setting of the lower links

Fix the lower links after coupling the implement. Lateral free movement of the lower links causes unstable drive properties during transport journeys and can cause accidents.

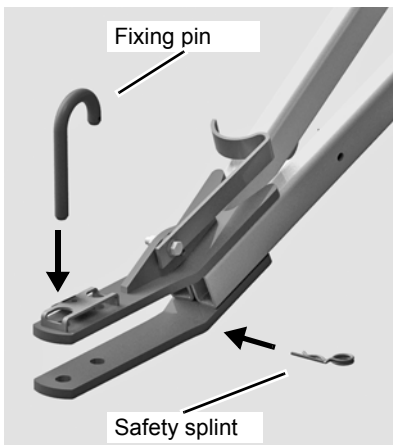
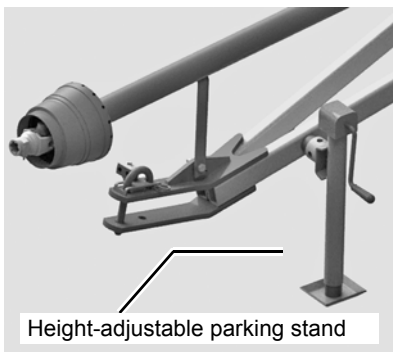

For coupling to a pending attachment in accordance with ISO 6489-3, proceed as follows:

- ▶ (A) Distance between the PTO shaft drive and the drawbar hitching point: approximately 356 mm.
 - ▶ (B) Height between the PTO shaft drive and the drawbar hitching point: approximately 203 – 305 mm.
 - ▶ (C) Fix the lower link height at a distance of approximately 400 mm from the ground.
-
- ▶ Couple the rotary rake to the pending attachment with a fixing pin.
 - ▶ Secure the fixing pin with a safety splint.
 - ▶ Take the height-adjustable parking stand out of the transport holder bracket and fit it to the drawbar.
→ See »Coupling to the lift link drawbar«, page 32.



The working depth is adjusted on the chassis.

→ Chapter »Preparing for use«, section »Rotor pitch«, page 39

Coupling the machine

Coupling to the lift link drawbar

The factory-supplied PTO shaft only allows for coupling to the pending attachment. The PTO shaft supplied is too short for coupling to the lift link drawbar. For a longer PTO shaft, please contact your dealer.

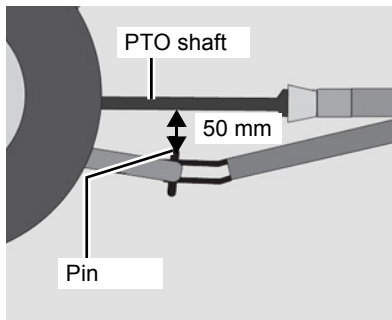

Ensure the minimum spacing

In the work position, the space between the PTO shaft and the pin must never be less than 50 mm. Otherwise the PTO shaft may be damaged, for example when driving over an undulation in the ground. Damaged PTO shafts can cause injury to persons or damage the machine.

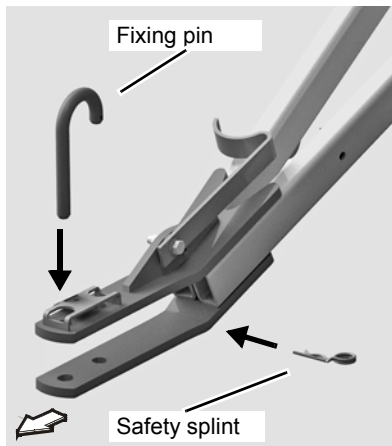

- ▶ Couple the rotary rake to the lift link drawbar with a fixing pin.
- ▶ Secure the fixing pin with a safety splint.
- ▶ Take the height-adjustable parking stand out of the transport holder bracket and fit it to the drawbar.
→ See »Coupling to the lift link drawbar«, page 32.

Stowing the height-adjustable parking stand [+]

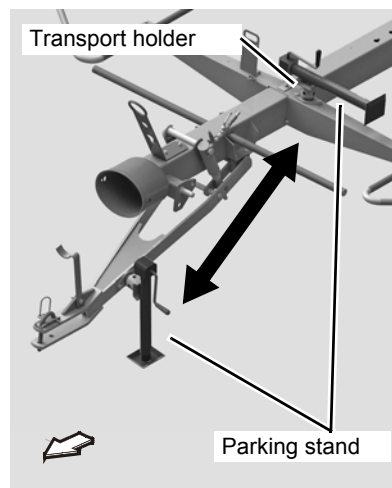

After coupling, remove the height-adjustable parking stand [+] and fit and secure it to the transport holder.



- ▶ Switch off the tractor and secure it.
- ▶ Pull the pin on the parking stand.
- ▶ Remove the parking stand.
- ▶ Fit the parking stand to the transport holder and secure it with a fixing pin.

Adjusting the drawbar cylinder

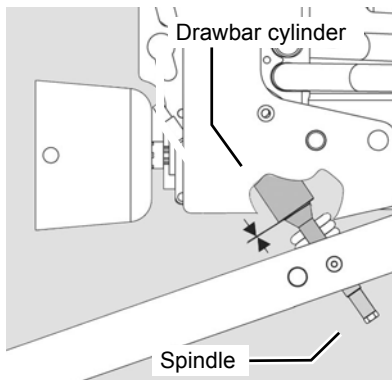

The drawbar cylinder is used to adjust the height of the drawbar and the machine pitch so that the crop can be picked up satisfactorily. The drawbar cylinder is adjusted differently depending on the equipment: Proceed as follows.

Operation without optional support wheel:

- ▶ Fully screw in the spindle on the drawbar cylinder.
- ▶ Set the tractor's hydraulic control device to the floating position.

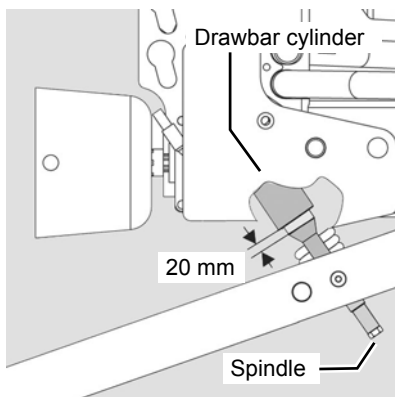

When the optionally available support wheel is used, the spindle on the drawbar cylinder must be adjusted to compensate for the ground undulations.

Operation with optional support wheel:

- ▶ Unscrew the spindle on the drawbar cylinder by about 20 mm.



Spanner size "17" on the spindle



In the case of the optional support wheel, ensure that a lift of at least 10 mm is always guaranteed for the drawbar cylinder.

Coupling the machine

Coupling the PTO shaft

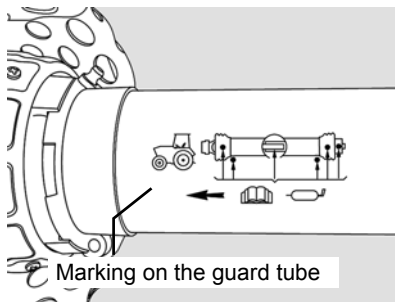

When coupling the PTO shaft, make sure it is in the correct position.

- ▶ Check whether the PTO shaft must be shortened before coupling.
- ▶ Shorten the PTO shaft if necessary.
→ »Length of PTO shaft«, page 27
- ▶ Check that the tractor's PTO stub shaft is clean and lubricated.
- ▶ Couple the PTO shaft to the tractor and the machine.
 - Fit the wide-angle joint on the tractor side.
- ▶ Ensure that the PTO shaft is engaged on the shaft ends.
- ▶ Secure the guard tubes so that they cannot rotate at the same time.
- ▶ Couple the single joint with slip clutch to the machine's PTO stub shaft.

Connecting the electrics [+]



Check the electrical cables

Check the electrical cables. The electrical cables must not chafe or hang loose. Electrical cables that have been torn away or worn through must be replaced. Otherwise, this will cause damage to the machine.

Attach the following electrical cables to the tractor:

Lighting equipment [+]



- ▶ Connect the plug for the 12 V power supply to the 7-pin plug socket on the tractor.

Illuminated warning signs USA [+]

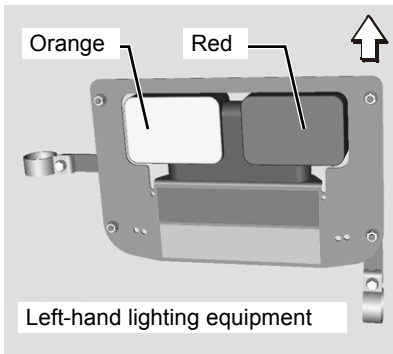

The optional warning sign kit with lighting equipment for the USA is available for operation in the USA and Canada. The lighting equipment is mounted on the left and right-hand side of the rear guard bar and connected to the tractor by a 7-pin plug. The corresponding connection must be present on the tractor (SAE J560).



If your tractor does not have the corresponding connection, this must be retrofitted. Consult your dealer.



The lighting equipment is controlled by the lighting controls in the tractor. The lights are only on if the tractor is in park position or the tractor's headlights are switched on.

- ▶ Connect the plug for the 12 V power supply to the 7-pin plug socket on the tractor.
- ▶ Check that the lighting equipment is functioning using the following table:

Tractor lights	Device lights			
	Left orange	Left red	Right red	Right orange
Headlight "OFF"	—	Off	Off	—
Headlight "ON"	—	Dimmed	Dimmed	—
Orange indicator light "OFF"	Off	—	—	Off
Orange indicator light "ON"	Flashing (same frequency as right)	—	—	Flashing (same frequency as left)
Brake lights (for tractors with brake lights)	—	Bright	Bright	—
Orange indicator light "ON" No turning indicated (tractor with brake lights)	Flashing (same frequency as right)	Bright	Bright	Flashing (same frequency as left)
Orange indicator light "ON" No turning indicated (no tractor brake lights)	Flashing (same frequency as right)	Off	Off	Flashing (same frequency as left)
Turning left indicated	Higher flashing frequency	Depending on tractor equipment: Off, dimmed or flashing in sync with the left-hand light	Off or dimmed	Illuminated, no flashing
Turning right indicated	Illuminated, no flashing	Off or dimmed	Depending on tractor equipment: Off, dimmed or flashing in sync with the right-hand light	Higher flashing frequency



Observe local regulations governing lighting equipment for travelling on the road. Consult your dealer if the lighting equipment does not function as stated.

Coupling the machine

Power adapter USA [+]

- ▶ A specific power adapter is available for the USA.

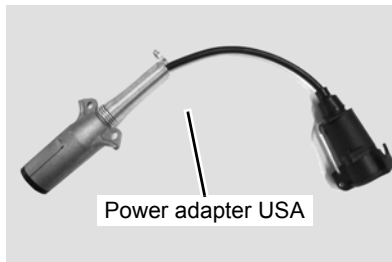

Connecting the hydraulics



Check hoses and couplings

Check all hydraulic hoses for damage before connecting them. Check all hydraulic couplings for firm seating after connecting them. Defective hydraulic hoses and poorly fitting hydraulic connections can trigger unpredictable movements of the machine, causing severe damage to the machine as well as personal injury. Serious or fatal injury may be caused as a result.

Secure the tractor's control devices

In the transport position, secure the tractor's control devices against unintended actuation and lock them if possible. Unintentional activation of a control device can trigger unpredictable movements of the machine and cause serious machine damage and personal injury. Serious or fatal injury may be caused as a result.

Check the routing of the hydraulic hoses

Close or disconnect the quick-release couplings with great care. Remove any dirt or air which has entered the hydraulic system. The hydraulic system may otherwise be seriously damaged. Material damage or personal injury may be caused as a result.

Avoid mixing oils

If the machine is used on different tractors, an impermissible mixing of oil may occur. Impermissible oil mixtures can irreparably damage tractor components.

Connecting the hydraulic couplings



Ensure the connection is correct

Make sure that the hydraulics are connected correctly. Otherwise, injuries and damage to the machine may be caused as a result.



- ▶ Close the ball valve.
- ▶ Set the tractor hydraulics to "free float".
- ▶ Switch off the tractor and secure it.



- ▶ Connect the machine's hydraulic coupling to the single-acting hydraulic control device.

Preparing for use

Safety

The following applies to all preparations for operation:



Observe the safety information

Observe the safety information. Disregard for safety information can lead to serious or fatal injury. See chapter »Safety«, page 6.

Secure the machine

Secure the machine against unintentional starting and rolling away. Use wheel chocks. The machine must stand on a level, firm and secure surface and be supported during the work, if necessary. Unsecured or non-supported machines can cause accidents. Otherwise, serious or fatal injury may be caused as a result.

No persons in the working area

Ensure that no persons are present in the slewing and working area of the machine. Persons could be caught by the machine within this area. This could result in fatal injury.

Remove tine supports

When carrying out adjustment work on the machine, tine supports which hinder work on the machine must be removed. Tine supports that are not removed can cause serious injuries.

General

The following applies when performing all adjustment work:

- ▶ Check the tyre pressure.
- ▶ Secure the machine.
- ▶ Lower the machine to the work position.
- ▶ Undo the appropriate bolts.
- ▶ Make the required adjustment.
- ▶ Retighten the bolts.
- ▶ Fit and secure the tine supports.

The following worksteps are described in this section:

- »Rotor pitch«
- »Working depth«

Rotor pitch

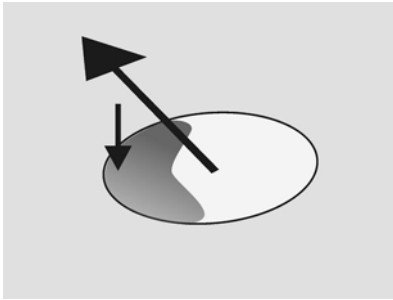

Close the ball valve

Close the ball valve before working on the machine or carrying out any adjustment work. If the ball valve is open and there is an operating error, the machine can lower itself and cause serious injuries.

The rotors are inclined transversely to the chassis. The rotor is already inclined transversely ex-factory. If the crop is not picked up cleanly, the raking quality can be improved by adjusting the rotor pitch.



The optimum raking quality is achieved when the tines in the front working area and before the crop is deposited have the lowest possible ground clearance (see adjacent illustration).

Adjusting the rotor pitch

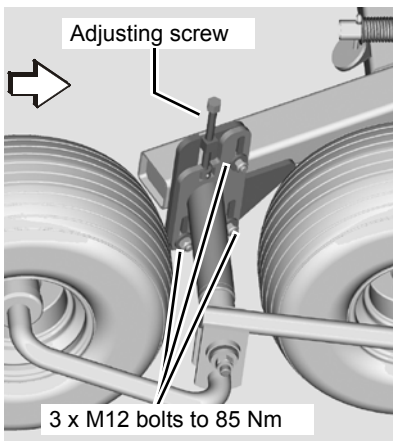

It is possible to adjust the position of the rotors laterally to the direction of travel.

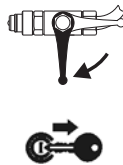

- ▶ Move the machine to the headland position using the tractor's control device.
- ▶ Close the ball valve.
- ▶ Switch off the tractor and secure it.
- ▶ Remove the tine supports above the right-hand wheel carrier.
- ▶ Slightly loosen the three bolts on the wheel carrier.
- ▶ Move the wheel carriers into the required position using the adjusting screw (see illustration below).
- ▶ Retighten the bolts to a tightening torque of 85 Nm.
- ▶ Fit and secure the tine supports.

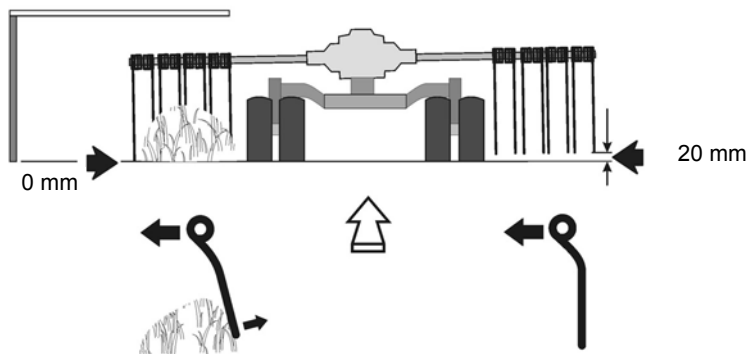

Crop pickup increases the distance between the tines and the ground.

Preparing for use

Working depth

When working, the machine is raised and lowered hydraulically. The machine is lowered as far as the preadjusted depth. The basic setting for the working depth is adjusted using an adjusting screw on the chassis cylinder.

Checking the working depth

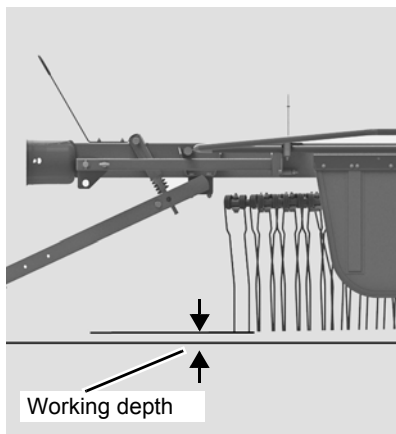

Check the preset working depth as follows:



- ▶ Fully lower the machine using the tractor's hydraulic control device.
- ▶ Switch off the tractor and secure it.
- ▶ Check the working depth to the ground.



The ideal working depth depends on several factors. Decisive, among others, are:

- The soil condition and the stubble length.
- The type and quantity of fodder

If the tines are positioned too low, the crop is contaminated and the stress and wear on the tines, and thus on the drive, increases. If necessary, adjust the working depth to the field again.

Adjusting the working depth

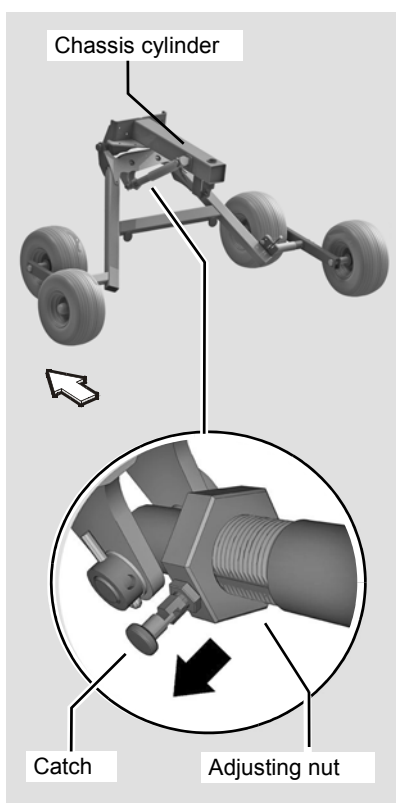

The chassis cylinder is used to adjust the chassis end stop in the work position. Start with a horizontal chassis basic setting at a hitch height of 400 mm. The chassis pitch depends on the ground conditions and the crop. Adjust the working depth as follows:



- ▶ Use the tractor's hydraulic control device to move the machine into the headland position.
- ▶ Switch off the tractor and secure it.

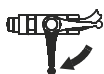

- ▶ Close the ball valve.
- ▶ Release the adjusting nut below the chassis using the catch and use the adjusting nut to adjust the working depth.
- ▶ Use the catch to prevent the adjusting nut from moving.



- ▶ Switch on the tractor.



- ▶ Lower the machine.
- ▶ Switch off the tractor and secure it.
- ▶ Check the working depth and readjust it if required.



Two turns of the adjusting nut change the height by 15 mm on the tines.

Adjusting the drawbar height

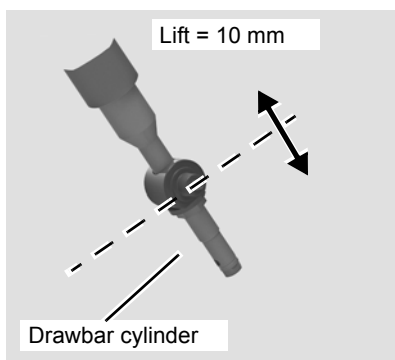
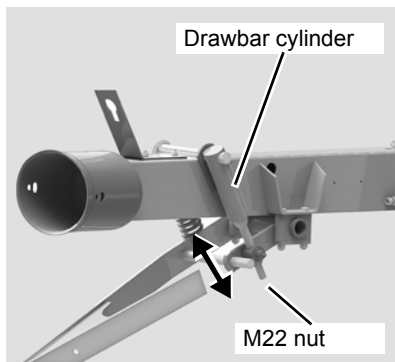

The drawbar cylinder is used to adjust the height of the drawbar and the machine pitch so that the crop can be picked up satisfactorily. Proceed as follows.

- ▶ Using the nut on the drawbar cylinder, adjust the working depth so that the tines lightly touch the ground (approx. 400 mm to the pending attachment).



When using the optional support wheel, ensure that a lift of at least 10 mm is guaranteed for the drawbar cylinder.

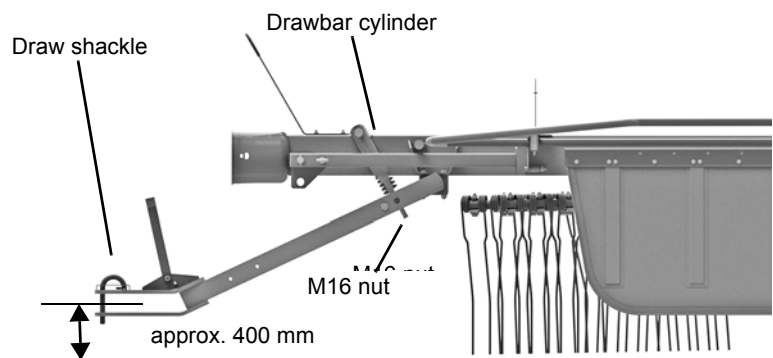

Safety

Before transporting the machine on public roads, please read the following safety information. Compliance is mandatory and will help you to avoid accidents.



Observe the safety information

Observe the safety information. Disregard for safety information can lead to serious or fatal injury. See chapter »Safety«, page 6.

Ensuring road safety

The machine must conform to current national traffic regulations if you intend to drive with it on public roads. Ensure the following:

- Lighting, warning and protective equipment must be fitted.
- The permissible transport widths and weights, axle loads, tyre load-bearing capacities, laden weights and national speed restrictions must be complied with.
- The maximum permissible road transport speed must be complied with, but not exceed 50 km/h.
- The machine should only be towed by agricultural or forestry tractors.
- The empty weight of the tractor must be greater than the weight of the machine.

The driver and keeper of the vehicle are liable should these conditions not be observed.

Clean the machine before travelling on the road

Before travelling on the road, remove all coarse dirt, crop residues and clods of earth from the machine and clean it. Crops or dirt that drop onto the road can cause slippery road conditions. There is otherwise the risk of traffic accidents and accidents with fatal consequences.

Observe the contour of the terrain

Move the machine onto ground that is as flat as possible before changing from work to transport position. Avoid inclines on which the combination (tractor and machine) could slip or overturn. There is an increased risk of tipping and injury in a position at right angles to the direction of the slope.



Close the ball valve

Close the ball valve before driving on the road. If the ball valve is open and there is an operating error, the machine may drop or swing out unexpectedly. This could cause traffic accidents and accidents with fatal consequences.

General

The following worksteps are described in this section:

- »Prior to road transport«
- »Folding in the guard bars«
- »Folding the machine into the transport position«
- »Checking the machine«
- »Road transport«

Prior to road transport

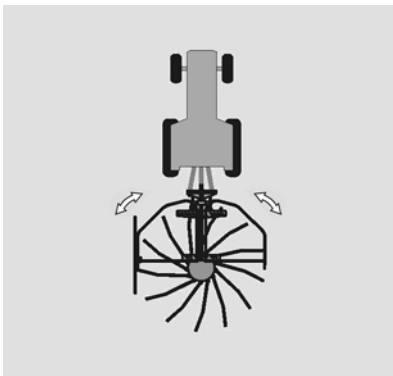

When driving on public roads, the machine must be in the transport position. To prepare the machine for road transport, carry out the following steps:

- ▶ »Moving the swath former to the transport position«
 - ▶ »Folding in the guard bars«
 - ▶ »Removing the tine supports«
 - ▶ »Placing the tine supports in the transport holder«
 - ▶ »Folding the machine into the transport position«
 - ▶ »Checking the machine«
- ▶ Move the machine onto ground that is as flat as possible before changing from work to transport position.

Moving the swath former to the transport position

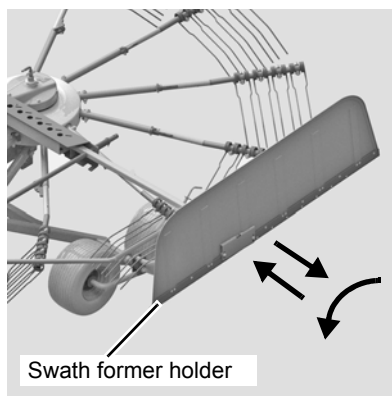

For the transport position with the lowest transport width, pull the swath former out of the holder, turn it 180° and push it fully back in and secure it.

The swath former consists of a board and a holder.

- ▶ In the work position, release the T-bolt from the swath former.
- ▶ Completely pull the swath former out of the holder.
- ▶ Turn the swath former 180° and push it back into the holder the other way round.
- ▶ Secure the swath former with the T-bolt.

Road transport

Folding in the guard bars

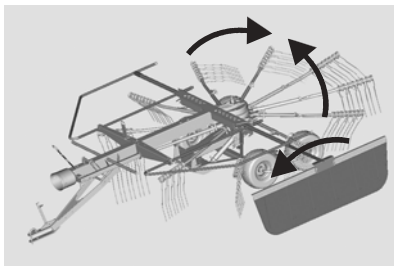

No persons within the slewing range

There is an acute risk of injury within the slewing range from machine parts which are slewing or folding. Otherwise, serious or fatal injury may be caused as a result.

Before removing the tine supports, move all the protective devices around the rotors from the work to the transport position, and lock them in place. Fold in the guard bar as follows:

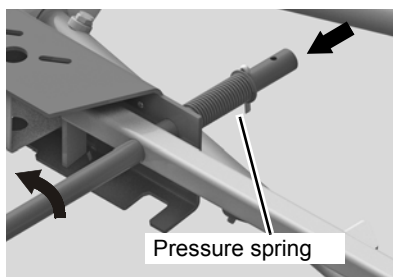

Pressure spring



- ▶ Lower the machine to the work position using the tractor's single-acting hydraulic control device.
- ▶ Switch off the tractor and secure it.
- ▶ Pull the swath former out of the holder.
- ▶ Fully insert the swath former.

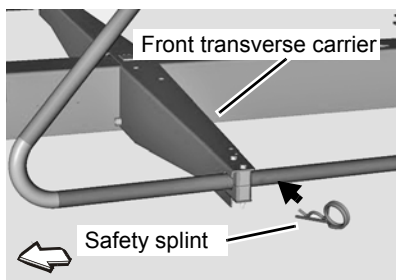

Front transverse carrier

Safety splint

Left guard bar

- ▶ Pull the left guard bar with swath former forwards, against the resistance of the pressure spring, and fold upwards to 90°.
- ▶ Lock the guard bar in the vertical position.
- ▶ Secure the guard bar on the front support using a safety splint.

Right guard bar

- ▶ Pull the right guard bar forwards, against the resistance of the pressure spring, and fold upwards by 90°.
- ▶ Lock the guard bar in the vertical position.
- ▶ Secure the guard bar on the front support using a safety splint.

Removing the tine supports

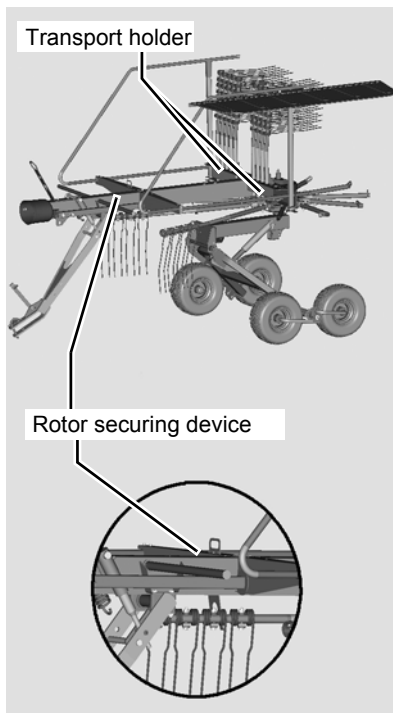

- ▶ Remove any crops and coarse dirt.
- ▶ Remove the tine supports from the rotor and secure them in the transport holder (see adjacent illustration).
- ▶ Do not remove one of the tine supports and secure using a rotor securing device.

Placing the tine supports in the transport holder

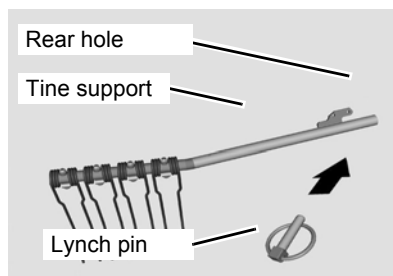

- ▶ Loosen and remove the lynch pin from the tine support.
- ▶ Pull off the tine support.

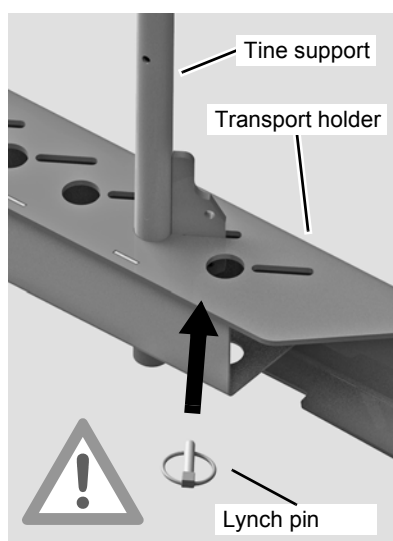

- ▶ Insert the tine support into the transport holder.
- ▶ Secure the tine support with a lynch pin.

Road transport

Folding the machine into the transport position

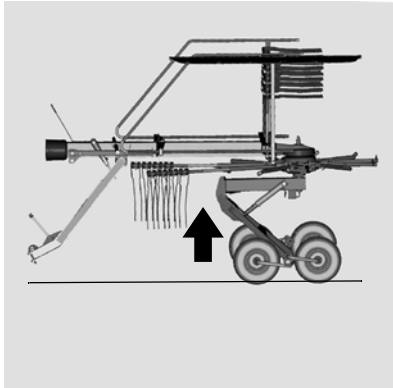

- ▶ Observe the instructions in »Prior to road transport«, page 43.
- ▶ Raise the rotor using the chassis hydraulics until the transport position is reached.



Do not raise the machine beyond the maximum permitted reflector height.

Checking the machine

Prior to driving on the road, check the machine against the check list:

- PTO shaft drive off?
- Guard bar folded in?
- Tine supports in the transport holder and secured?
- Tyre pressures correct?
- Lower link secured at the sides?
- Crop residue and dirt removed?
- Lighting cables routed so that they are not strained and cannot become caught in the tractor's wheels when cornering?
- Machine in transport position?
- Transport locking device locked?
- Lighting equipment in good working order?

Road transport



Follow the instructions below for road transport. There is otherwise the risk of traffic accidents and accidents with fatal consequences.

- ▶ Before pulling away, check the immediate vicinity. Always make sure that you have a clear field of vision and, in particular, look out for children within the operating area of the machine.
- ▶ Lock the control devices on the tractor before driving on public roads.
- ▶ Do not transport people or objects on the machine.
- ▶ Adjust your speed to road conditions.
- ▶ Do not exceed a maximum speed of 50 km/h. Comply with the national speed limits.
- ▶ Ensure sufficient steering and braking capability. Driving characteristics, steering, and braking capability are all influenced if the machine is coupled (increased braking distance as a result of greater inertia).

There is a danger of tipping on slopes and if corners are taken too fast.

Preparations on the field

Safety

The following applies for all preparations on the field:



Observe the safety information

Observe the safety information. Disregard for safety information can lead to serious or fatal injury. See chapter »Safety«, page 6.



Switch off the tractor and secure it

Before you dismount:

- ▶ Switch off the tractor.
- ▶ Remove the ignition key.
- ▶ Secure the tractor against rolling away.

An unsecured tractor can run you over or trap you. Otherwise, serious or fatal injury may be caused as a result.

Secure the machine

Secure the machine against unintentional starting and rolling away. Use wheel chocks. The machine must stand on a level, firm and secure surface and be supported during the work, if necessary. Unsecured or non-supported machines can cause accidents. Otherwise, serious or fatal injury may be caused as a result.

No persons in the working area

Ensure that no persons are present in the slewing and working area of the machine. Persons could be caught by the machine within this area. This could result in fatal injury.



Close the ball valve

Close the ball valve before adjusting. If the ball valve is open and there is an operating error, the machine may drop or swing out unexpectedly. This may cause damage to the machine or accidents with fatal consequences.

General

The following worksteps are described in this section:

- »Lowering the machine«
- »Fitting the tine supports«
- »Folding out the guard bars«
- »Adjusting the swath former«

Basic settings

After road transport, the machine is brought into the work position on the field.

Lowering the machine

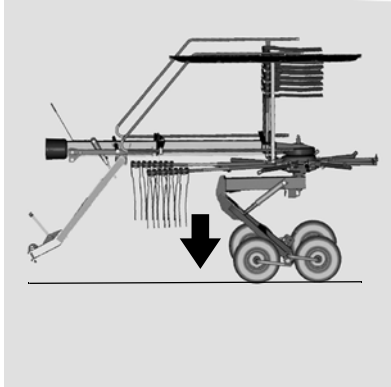

▶ Switch on the tractor.

▶ Lower the rotor using the chassis hydraulics until the work position is reached.



▶ Switch off the tractor and secure it.

Fitting the tine supports

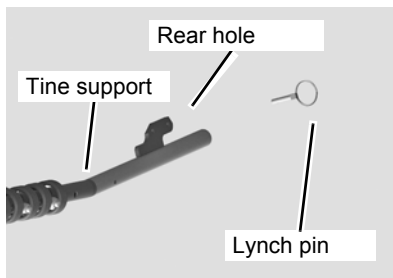

▶ Remove the tine supports from the transport holder.

▶ Attach the tine supports to the bushed bearing tube and secure with lynch pins.

Preparations on the field

Folding out the guard bars

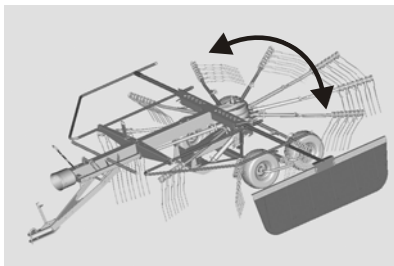

No persons within the slewing range

There is an acute risk of injury within the slewing range from machine parts which are slewing or folding. Otherwise, serious or fatal injury may be caused as a result.

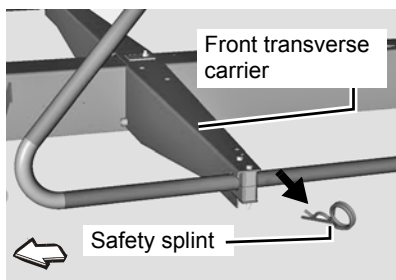

After the tines have been attached, all protective devices must be moved from transport to work position. Fold out the guard bar as follows:

Left guard bar

- ▶ Remove the safety splint from the front support.
- ▶ Pull the left guard bar with swath former forwards, against the resistance of the pressure spring, and fold downwards by 90°.

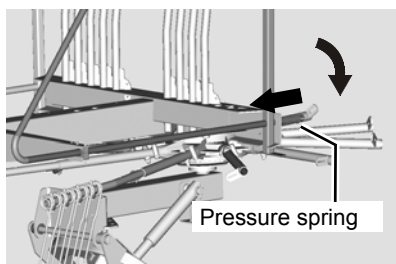

Right guard bar

- ▶ Remove the safety splint from the front support.
 - ▶ Pull the right guard bar forwards, against the resistance of the pressure spring, and fold downwards by 90°.
- ▶ Observe the instructions in chapter »Preparing for use«, section »Working depth« on page 40.

Adjusting the swath former

The swath former is pulled into the correct position and secured when changing from the transport to the work position.

For the work position, pull the swath former out of the holder, turn it 180° and push it fully back in and secure it.

Adjusting the swath width

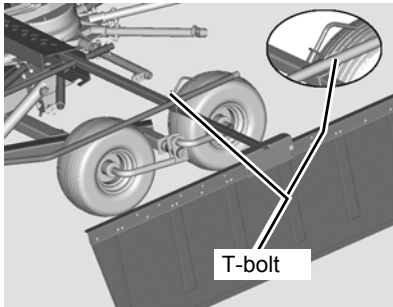

The swath width can be adjusted as follows:

- ▶ Undo the T-bolt.
- ▶ Pull out the swath former to the desired width.
- ▶ Tighten the T-bolt in the new position and secure.

Adjusting the swath former in relation to the direction of travel

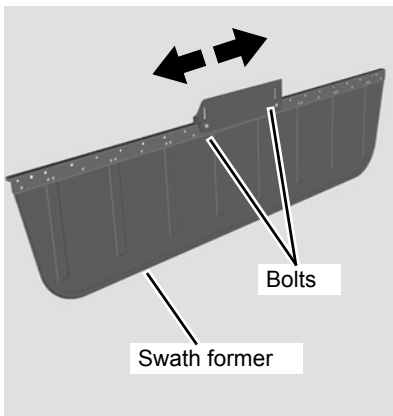

It is possible to adjust the direction of travel of the swath former as follows:

- ▶ Remove the bolts.
- ▶ Move the swath former into the desired position.
- ▶ Fit the bolts and tighten them in the new position.

Adjusting the swath former's height

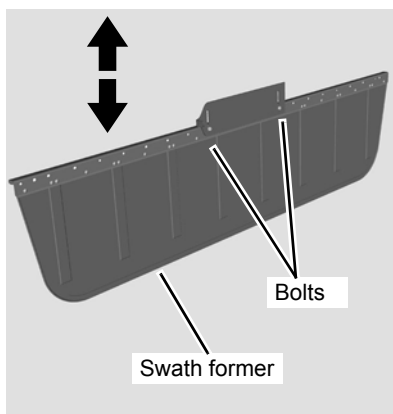

It is possible to adjust the height of the swath former as follows:

- ▶ Loosen the bolts.
- ▶ Adjust the height of the swath former.
- ▶ Tighten the bolts in the new position.

Safety



Observe the safety information

Observe the safety information. Disregard for safety information can lead to serious or fatal injury. See chapter »Safety«, page 6.

No riding on the machine

Persons or objects must never be transported on the machine. Carrying passengers on the machine is life-threatening and prohibited. Serious or fatal injury may be caused as a result.

No persons in the working area

Ensure that no persons are present in the slewing and working area of the machine. Persons could be caught by the machine within this area. This could result in fatal injury.

Maximum PTO stub shaft speed 540 rpm

The PTO stub shaft speed must not exceed 540 rpm and must be adapted to the condition of the crop. Higher revolution rates can cause damage to the machine.

Only allow the PTO shaft clutch to respond for a short time

Do not allow the slip clutch to respond for longer than 3 seconds. If the clutch responds for a longer period of time, it will become worn and the disconnect torque will drop.

Do not compress the PTO shaft

The PTO shaft between the tractor and machine must not be compressed when in the work position or transport position. If compressed, PTO shafts can cause damage to the machine and tractor.

Observe the contour of the terrain

Pay even more attention when driving on an incline. Avoid inclines on which the combination (tractor and machine) could slip or overturn. There is an increased risk of tipping and injury in a position at right angles to the direction of the slope.

Changes in the centre of gravity

When in work position, the machine's centre of gravity changes. Pay even more attention when driving on an incline. Avoid inclines on which the combination (tractor and machine) could slip or overturn. There is an increased risk of tipping and injury in a position at right angles to the direction of the slope.

General

The following worksteps are described in this section:

- »Swathing«
- »Driving on headlands«



Suitable working speeds

Select a driving speed (approx. 4 to 12 km/h) at which the crop is picked up cleanly and completely. The working speed depends on the machine settings and the particular crop.

Swath width

The swath width depends on the working width, working speed, rotor settings as well as crop condition.

Operation

Swathing



No persons in the working area

Ensure that no persons are present in the slewing and working area of the machine. Persons could be caught by the machine within this area. This could result in fatal injury.

Requirements

After setting the machine as described in chapter »Preparations on the field« page 48, you can start swathing.

The machine is set correctly as follows:

- Swath former adjusted.
- Tine supports are attached and secured.
- Rotor securing device on the rotor released.
- Tractor's lower links are set to floating position.
- Machine in work position.

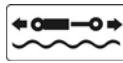

Start work as follows:



- ▶ Switch on the tractor.

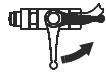

- ▶ Open the ball valve.

- ▶ Check that there is nobody in the working area of the machine.
- ▶ Switch on the PTO shaft at a low engine speed.
- ▶ Slowly increase the speed. Do not exceed the maximum speed of 540 rpm.
- ▶ Select a driving speed at which the crop is picked up cleanly and completely.

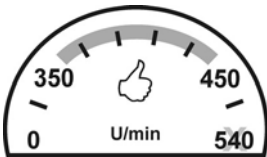

Start swathing at the edge of the field and at headlands to avoid subsequently driving over the crop.

The slip clutch of the machine may also respond at low speed if resistance is increased due to excess crop or obstacles.

Swath deposit

The following swath deposits are possible:

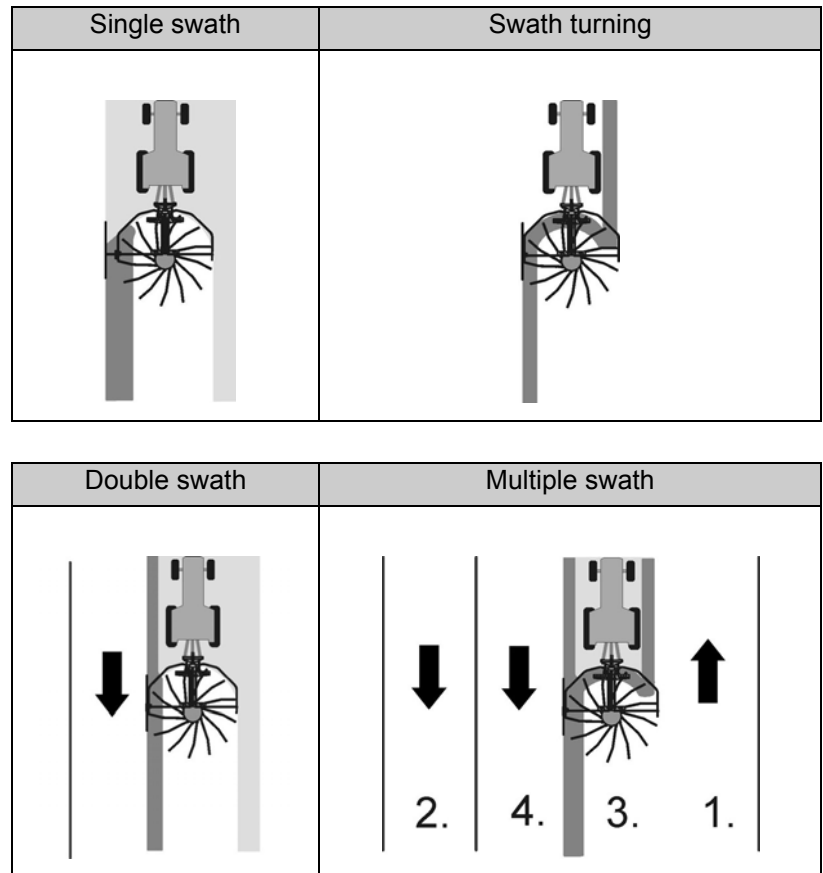

Driving on headlands

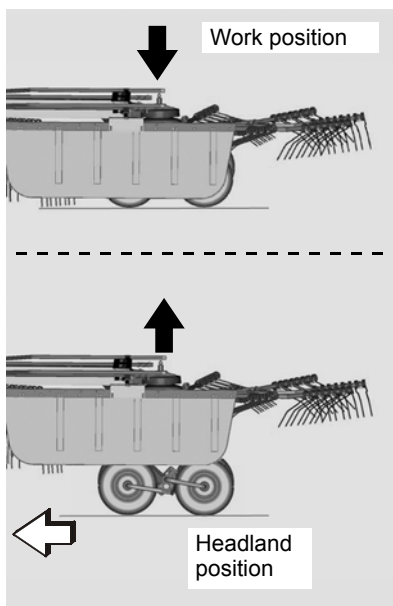

The rotor can be raised for crossing swaths that have already been harvested.

- ▶ Raise the machine to the headland position using the tractor's single-acting hydraulic control device.
- ▶ Lower the machine again, in order to create a new swath.

Safety

The following applies to all cleaning and care work:



Observe the safety information

Observe the safety information. Disregard for safety information can lead to serious or fatal injury. See chapter »Safety«, page 6.

Secure the machine

- Before starting cleaning operations, always switch off the tractor's PTO shaft drive and secure it against unintentional restarting.
- Secure the machine against rolling away by using chocks.
- The machine must be standing on firm and level ground and, if necessary, be supported during the work.

Unsecured or non-supported machines can cause accidents.

No persons in the working area

Ensure that no persons are present in the slewing and working area of the machine. Persons could be caught by the machine within this area. This could result in fatal injury.

Do not clean bearings or hydraulic parts with high-pressure cleaners

Do not clean bearings or hydraulic parts with high-pressure cleaners. The high-pressure cleaner removes the grease film from the bare metal surfaces. Metal surfaces treated in this way can corrode. After each cleaning procedure, lubricate the bearing points and grease uncoated parts.

Clean the bearings and hydraulic parts with care

Exercise caution when cleaning with a high-pressure cleaner. Bearings, seals and pipe unions are not waterproof. In order to prevent damage to the machine, the bearings, seals and pipe unions must not be exposed to direct contact with the high-pressure water jet.

Cleaning

- ▶ Lower the machine to the work position.
- ▶ After each use, clean the machine of any coarse dirt and crop residue.
- ▶ Do not clean the bearings and piston rods of hydraulic cylinders using a high-pressure cleaner.

After cleaning

- ▶ Lubricate all bearings after cleaning.

Care

For a long service life, we recommend the following:

- ▶ Apply a protective layer of oil to all uncoated work tools. Only use approved, biodegradable oil, e.g. rapeseed oil.
- ▶ Repair any paint damage.

Parking and storage

Safety

When setting down and parking the machine, special safety precautions have to be observed:



Observe the safety information

Observe the safety information. Disregard for safety information can lead to serious or fatal injury. See chapter »Safety«, page 6.

Keep children away from the machine

Forbid children from playing on or around the machine. Select a parking area to which no unauthorised persons have direct access. Metal edges and machine work tools can cause serious injury.

Make sure the machine is standing level

Before changing from the transport to the work position (and vice versa), make sure the machine is standing level. The machine could roll away, particularly on hillside locations. Damage to the machine and serious or fatal injury may be caused as a result.

General

The machine must be uncoupled in the reverse order to that in which it was coupled.

- Chapter »Folding the machine into the transport position« page 46.
- Chapter »Coupling the machine«, section »Coupling« page 13.

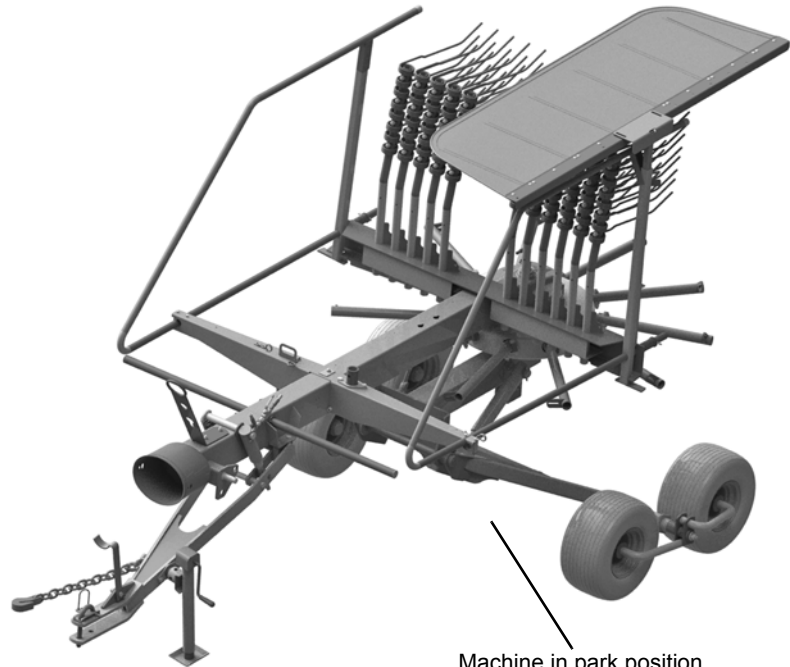

Machine in park position

Uncoupling the machine

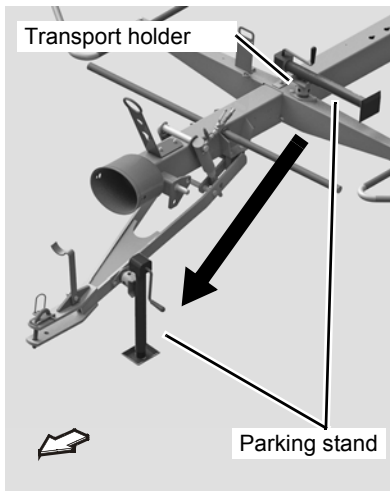

To uncouple the machine from the tractor, proceed as follows:

- ▶ Set the machine down on a firm, level surface and lower it to the work position.
- ▶ Secure the tractor against rolling away, turn off the engine and remove the ignition key.
- ▶ Secure the machine against rolling away by using chocks.
- ▶ Pull off the PTO shaft and place it on the holder provided.
- ▶ Close the ball valve and release the hydraulic couplings.
- ▶ Place hydraulic couplings in storage pockets.
- ▶ Remove the tine supports.
- ▶ Disconnect the lighting connectors and place them in the storage pockets.
- ▶ Fasten the height-adjustable parking stand to the drawbar, secure it, and relieve the drawbar with the parking stand.
- ▶ Wind the electrical cables onto the hook.
- ▶ Unhitch the machine.

Parking and storage

After the end of the season

After the end of the season and if the machine is to be stored for a long period of time, perform the following work:

- ▶ Clean the machine thoroughly.
- ▶ Check all the screwed connections and tighten the bolts.
- ▶ Repair or replace any damaged components.
- ▶ Repair any paint damage.
- ▶ Lubricate the machine in accordance with the lubrication schedule.
- ▶ Check the tyre pressures.
- ▶ Replace missing warning signs and stickers.

Safety

The following applies to all maintenance work:



Observe the safety information

Observe the safety information. Disregard for safety information can lead to serious or fatal injury. See chapter »Safety«, page 6.

Requirements for maintenance work

Only perform the maintenance work if you have the required expert knowledge and suitable tools. The absence of technical knowledge or suitable tools can cause accidents and injuries.

Protect the machine against unintended starting

The following conditions must be observed for carrying out repairs and maintenance work and rectifying malfunctions on the machine when it is coupled:

- Switch off the tractor PTO shaft drive.
- Switch off the tractor engine.
- Remove the ignition key.

Serious accidents may be caused if the machine starts unintentionally.

Use OEM replacement parts

Many components have special properties that are essential for the stability and correct operation of the machine. Only spare parts and accessories supplied by the manufacturer have been tested and approved. Other products may adversely affect the correct operation of the machine and safety. The use of non-OEM replacement parts renders the manufacturer's guarantee null and void and frees the manufacturer from all liability.

Secure moving parts

Moving parts must be secured with lifting gear against sliding, folding or swivelling. Otherwise, serious injury to persons or damage to the machine may be caused as a result.

Disconnect electrical connections before performing welding work

Disconnect all electrical connections from the tractor when carrying out welding on the hitched machine. Otherwise, electrical and hydraulic systems will be damaged as a result.

Maintenance

Protective measures when handling oils or lubricants

Additives in oils and lubricants may have adverse effects on health. As marking in accordance with the hazardous goods regulation is not necessary, please always ensure the following:



Avoid skin contact

Avoid skin contact with these materials. Protect your skin by means of protective skin cream or oil-resistant gloves. Contact can result in skin damage.

Do not use oils for cleaning

Do not use oils or lubricants to clean your hands. Swarf and abraded material in these materials can also result in injuries.

Change out of soiled clothing

Change out of clothing that is heavily soiled with oil as soon as possible. Oils can be hazardous to your health.



- Used oil must be collected and disposed of.
- If the skin is damaged by oil or lubricant, seek medical advice immediately.

General

This information relates to general maintenance work. For all maintenance work, the machine must be locked in the work position. If the transport position is required for maintenance work, refer to the relevant instructions for the work.

- ▶ Lower the machine to the work position.
- ▶ Secure the machine against rolling away by using chocks.

Direction information

Direction information (right, left, front, rear) is given in relation to the direction of travel. Rotary direction is defined as follows:

- Rotary direction right = clockwise.
- Rotary direction left = anticlockwise.
- Rotation about a vertical axis, viewed from top to bottom.
- Rotation about a horizontal axis, viewed at right angles to the direction of travel, from left to right.
- The rotation of bolts and nuts, etc. is always viewed from the operating side.

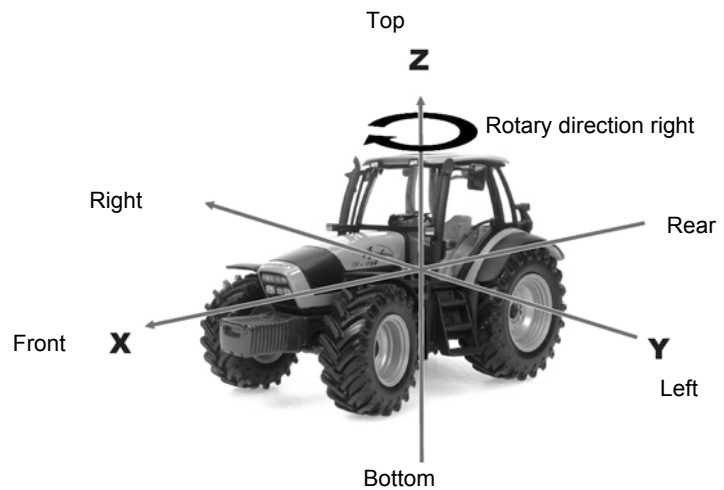

Maintenance

Maintenance terms

Listed in this table are short explanations of the most important maintenance terms.

Task	Explanation
Greasing	Apply grease to the slide surfaces using a brush.
Lubrication	One or two presses of the grease gun, unless specified otherwise.
Oiling	Unless specified otherwise, use only plant-based oils, such as rapeseed oils. The use of used oil will endanger your health and is also strictly prohibited.
Replacement	Replace the appropriate part in accordance with the instruction in the Maintenance chapter.
Inspection	Check the tyre pressures, adjustment dimensions and seal tightness as required, and replace any worn parts or seals.
Observe the maintenance intervals	The specifications relate to an average usage of the machine. If subjected to heavier duty (e.g. by contracting companies), select the maintenance intervals to be shorter. Also, for extreme working conditions (for example heavy dust creation), shorter maintenance intervals are possible.

Maintenance intervals

		After 5 hours of operation	Daily	After 20 hours of operation	After 50 hours of operation	After 250 hours of operation	Once per season	After heavy use	As required	In case of wear	Lubrication	Greasing	Inspection	Replacement	Cleaning	Page
General																
	All bolts	•					•		•							65
	Visual inspection		•					•					•			
	Bearing						•						•			67
	Hose connections						•						•			
	Air pressure		•				•		•				•			69
	Lighting equipment								•				•		•	
Hydraulics																
	Hydraulic hoses every 6 years													•		70
	Hydraulic cylinders						•						•			
	Hydraulic couplings						•						•			
PTO shafts																
	Wide-angle joint				•		•				•					67
	PTO shaft guard						•				•		•			68
	Profile section tube						•					•				68
Gear box																
	Rotor gear						•						•			69

Screwed connections

Tightening bolts

All bolts must be retightened:

- After the first 5 hours of operation.
- According to the frequency of use.
- At least once a season.

Special tightening torques

Observe the special tightening torques for the following screwed connections:

- 90 Nm spring tine.

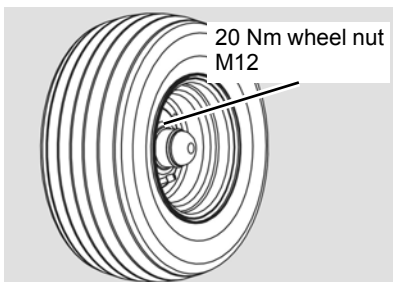
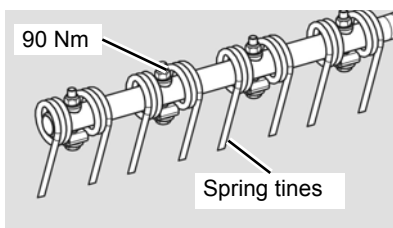

- 20 Nm Rotor chassis wheel nuts.

Maintenance

Tightening torques for screwed connections

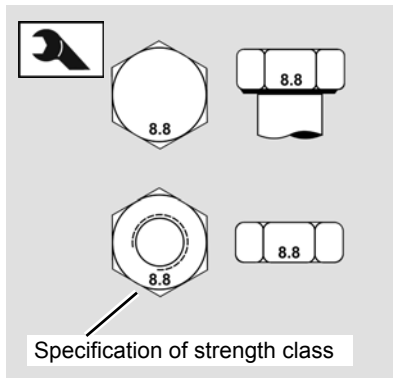

Use the correct screw and bolt tightening torque

Securely tighten screws, nuts and bolts to the specified torques. Otherwise, damage to the machine and serious or fatal injury may be caused as a result.

Note the strength class specification for screws, nuts and bolts. Refer to the table for the corresponding tightening torque. Securely tighten screws, nuts and bolts to the specified values, provided that no other value is specified. The torque specifications refer to a dry coefficient of friction (0.12).

	8.8	10.9	12.9
M6	9.9 Nm (7.3 ft.lbs)	14 Nm (10.3 ft.lbs)	17 Nm (12.5 ft.lbs)
M8	24 Nm (17.7 ft.lbs)	34 Nm (25 ft.lbs)	41 Nm (30.3 ft.lbs)
M10	48 Nm (35.4 ft.lbs)	68 Nm (50.2 ft.lbs)	81 Nm (59.8 ft.lbs)
M12	85 Nm (62.7 ft.lbs)	120 Nm (88.6 ft.lbs)	145 Nm (104 ft.lbs)
M14	135 Nm (99.6 ft.lbs)	190 Nm (140 ft.lbs)	230 Nm (166 ft.lbs)
M16	210 Nm (155 ft.lbs)	290 Nm (214 ft.lbs)	350 Nm (258 ft.lbs)
M20	410 Nm (302 ft.lbs)	580 Nm (428 ft.lbs)	690 Nm (509 ft.lbs)



Tighten safety bolts and lock nuts to a 10% higher value.

Lubrication points for grease

Working with a grease gun

Before applying the grease gun

- ▶ Clean the lubricating nipples and
- ▶ Clean the grease gun attachment fitting.

Lubricate the bearings with one or two presses of the grease gun. If you feel resistance at the second press, do not press a second time. Too much grease will force the bearings apart. Dust and dirt can penetrate into the bearings. This leads to premature wear.

Lubricate the places listed in the illustration as follows:

- after 50 hours of operation.
- before and after the season.
- each time after cleaning with a high-pressure cleaner.

PTO shaft coupling

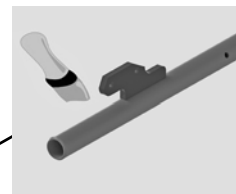
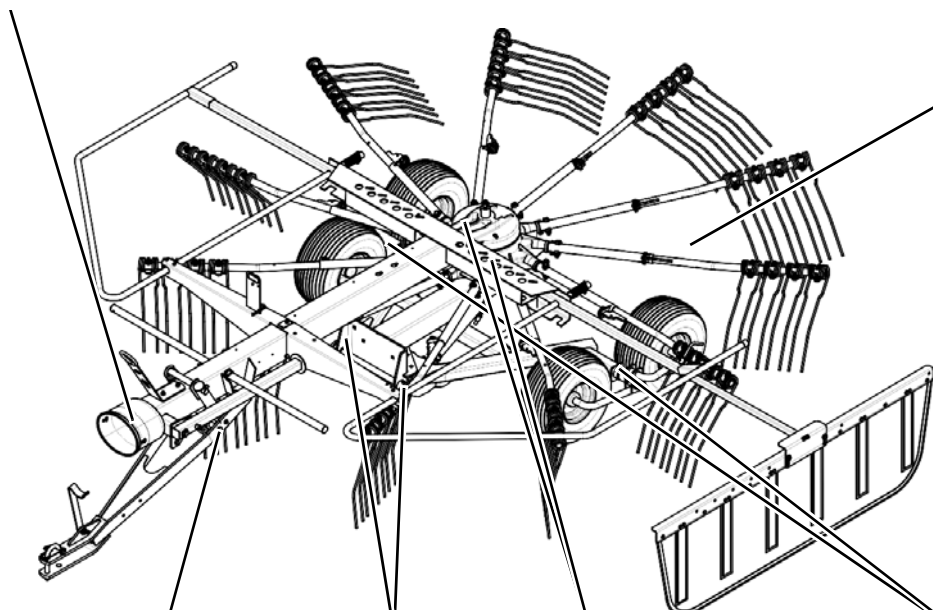

11 x tine arm shaft end

2 x drawbar cylinder

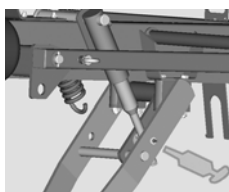

2 x axle carrier

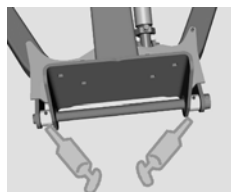

2 x gear box

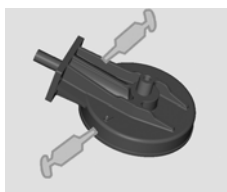

2 x tandem axle

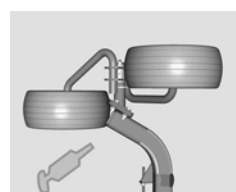

Maintenance

Lubricating the PTO shafts

The PTO shaft manufacturer's own operating manual is included with each PTO shaft. This includes detailed information on the relevant version of the PTO shaft.



Check the guard components

Check all guard components of the PTO shafts for wear or damage (visual inspection). Replace any defective guard components. An unguarded PTO shaft or damaged guard components can cause very serious injuries during operation.

Lubricate the single joints and their couplings as follows:

- after 60 hours of operation.
- before and after the season.
- each time after cleaning with a high-pressure cleaner.

Grease the profile section tubes:

- after 60 hours of operation.
- before and after the season.
- each time after cleaning with a high-pressure cleaner.

Lubricate the guard as follows:

- after 60 hours of operation.
- before and after the season.
- each time after cleaning with a high-pressure cleaner.

PTO shaft for the main drive

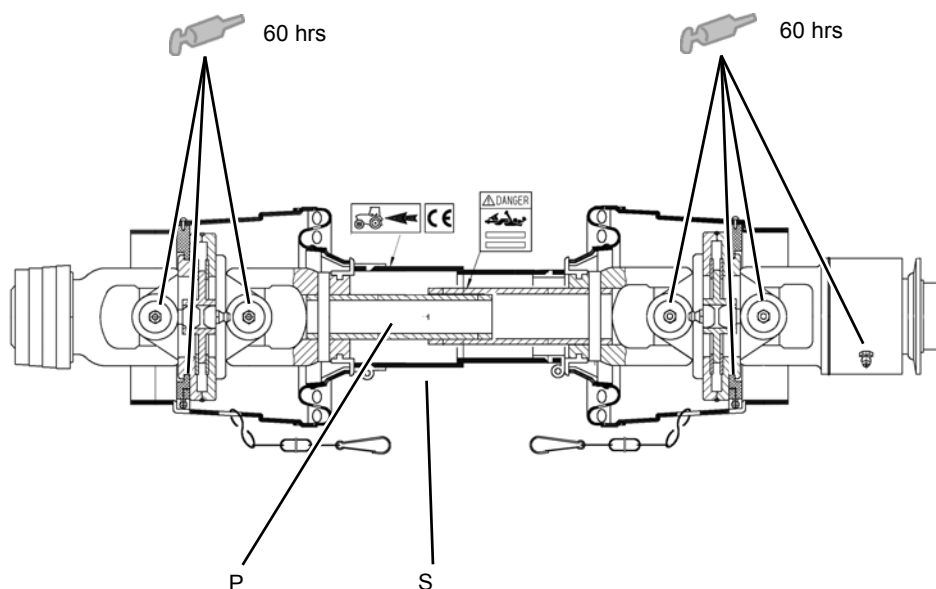

Filling quantities

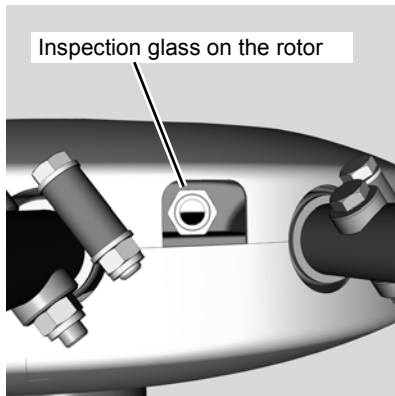

Check the oil level with the machine horizontal only if there is visible loss of oil. The oil level at the rotor gear is indicated by an inspection glass.

- ▶ Check the oil level at the rotor using the inspection glass.

If there is a visible loss of oil, top up to the required volume.

Gear box	Oil capacity [litres] SAE 90 API-GL-4
Rotor gear	6.2

Tyres



Do not drive with worn or damaged tyres

Replace worn or damaged tyres immediately. There is a high risk of accident when driving on the road with such tyres.

Tyre pressure

Check the tyre pressures on a regular basis:

- daily.
- Before any road transport
- as required (for example before setting the tine height).
- before and after the season.

	Tyre pressure [bar]
Rotor chassis	1.5

Hydraulics



Hydraulic system at zero pressure

Work must only be performed on the hydraulic system if the tractor and machine hydraulic system is at zero pressure. A pressurised hydraulic system can trigger unpredictable movements of the machine and can cause serious damage to the machine and personal injury. Serious or fatal injury may be caused as a result.

Exercise caution when welding

Do not perform any welding work in the vicinity of the hydraulic hoses. Hydraulic oil can catch fire very easily.

Clean hydraulic system

Close or disconnect the quick-release couplings with great care. Remove any dirt or air which has entered the hydraulic system. The hydraulic system may otherwise be seriously damaged. Material damage or personal injury may be caused as a result.

Collect escaping oil

Escaping oil must be collected and disposed of in accordance with national regulations. Otherwise, damage may be caused to the environment.

Hydraulic hoses



Replace hydraulic hoses every six years

Hydraulic hoses age without showing externally visible signs. Replace hydraulic hoses every six years. Defective hydraulic lines can cause serious or fatal injuries.



- ▶ Lower the machine to the work position.
- ▶ Depressurise the system.
- ▶ Switch off the tractor.
- ▶ Remove the ignition key.
- ▶ Disconnect the hydraulic hoses.
- ▶ Replace hydraulic hoses.

Optional accessories

You can purchase additional equipment through your dealer.

Tine saver [+]

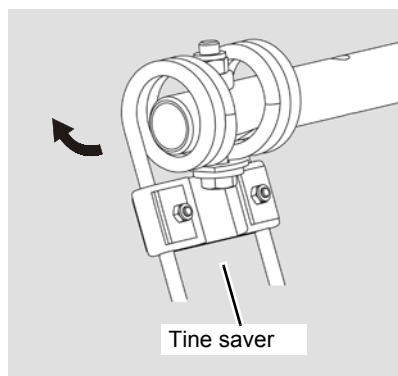

For a good swath deposit, both tine legs must run parallel to one another. This must also be ensured after fitting the tine saver.

Proceed as follows:

- ▶ Fit one tine saver on each tine.
- ▶ Check the direction of rotation of the rotor. The nuts must be attached against the rotor direction.
- ▶ Check the tine position. The tine legs must be parallel.
- ▶ If necessary, loosen the screwed connection until both tine legs run parallel.

Support wheel [+]

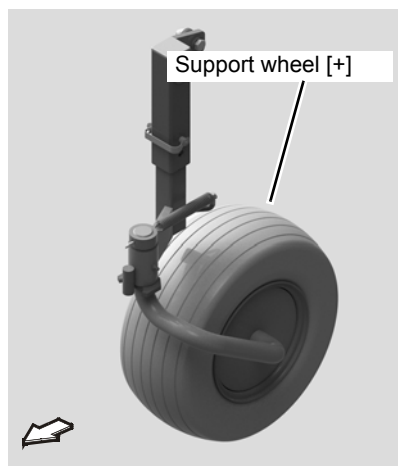

To ensure the machine offers even better contour guidance during operation, the manufacturer can also supply an optional support wheel. The support wheel can be fitted on the right or on the left.



When using the optional support wheel, ensure that a lift of at least 10 mm is guaranteed for the drawbar cylinder.

Lift link drawbar [+]

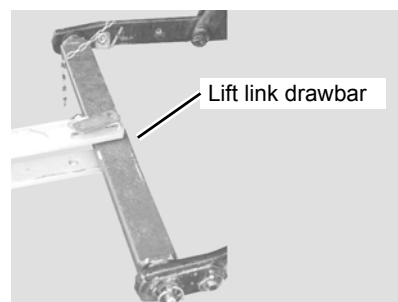

As a special accessory, there is a rotatable lift link drawbar for “category II”.

Additional equipment

Warning sign kit [+]

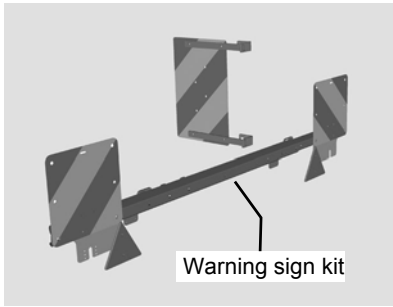

The optional warning sign kit increases safety when travelling on the road.

Lighting equipment set [+]

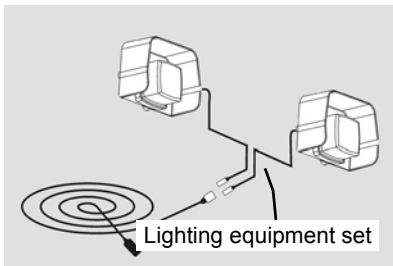

The optional lighting equipment set increases safety when travelling on the road.

Illuminated warning signs USA [+]

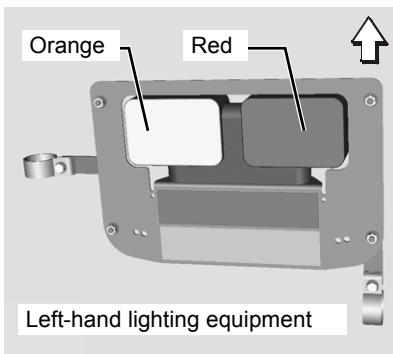

The optional kit increases safety when travelling on the road.

Power adapter USA [+]

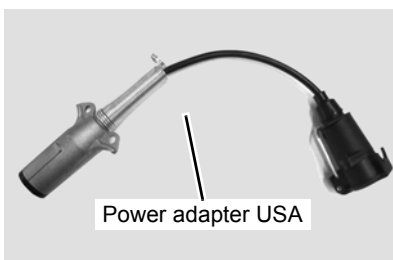

A specific power adapter is available for the USA.

Spare wheel [+]

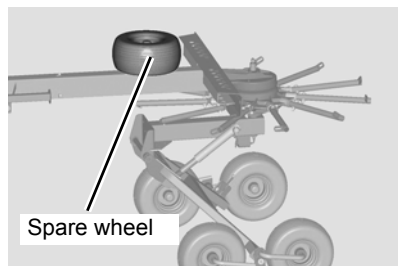

The optional spare wheel is mounted on the frame and can replace any one of the running wheels.

Fault elimination

Faults

Faults can often be eliminated quickly and easily. Before contacting Customer Service, refer to the table to check whether you can remedy the fault yourself.



In case of a fault, proceed as follows:

- ▶ Immediately stop operation.
- ▶ Switch off the tractor PTO shaft drive.
- ▶ Switch off the tractor and secure it.
- ▶ The fault must be repaired before work can be resumed. Otherwise, damage to the machine and serious or fatal injury may be caused as a result.

Problem	Cause	Solution
Rotor is leaving crop behind on one side and is digging too deeply into the ground on the other side.	Incorrect adjustment of rotor pitch.	→ Chapter »Preparing for use«, section »Rotor pitch«, page 39
Rotor is leaving crop behind across the entire width.	Working depth set too high.	→ Chapter »Preparing for use«, section »Rotor pitch«, page 39
Crop is heavily contaminated.	Rotor tines set too low.	→ Chapter »Preparing for use«, section »Rotor pitch«, page 39
		→ Chapter »Coupling the machine«, section »Coupling the machine«, page 30
Machine not operating cleanly at high speed.	Rotor tines set too high. Uneven terrain.	→ Chapter »Preparing for use«, section »Rotor pitch«, page 39
	Speed too high to process crop mass	Reduce speed.
Rotor dragging crop along – Unclean swath form	Crop mass too large.	Reduce speed.
	Rotary speed too high.	Reduce speed.
PTO shaft coupling responding frequently.	Crop mass too large or uneven.	Reduce speed.
	Rotor tines set too low.	→ Chapter »Preparing for use«, section »Rotor pitch«, page 39
Noise production during work	Loose screwed connections or worn-out tine supports. Tine support bent	Check tine supports and screwed connections on tines.
Machine rolls offset behind the tractor when driving in a straight line.	Steering/tracking incorrectly adjusted or worn out.	Contact dealer.
Rotor not working cleanly.	Poor adaptation to the contours of the land due to severe rotor load relief	Please consult your dealer. You will find assistance under »Circuit diagrams«, page 75.

Hydraulic system
connection
diagram

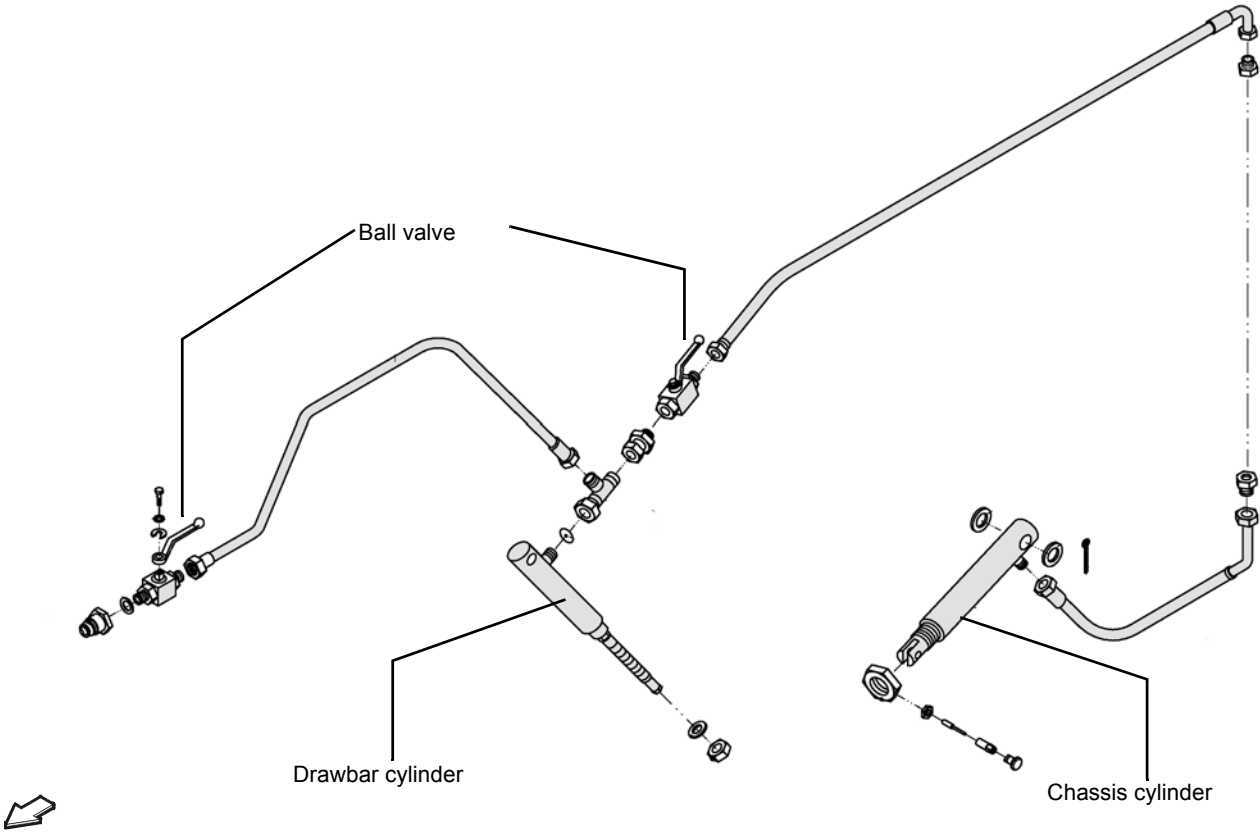

Circuit diagrams

Lighting equipment circuit diagram

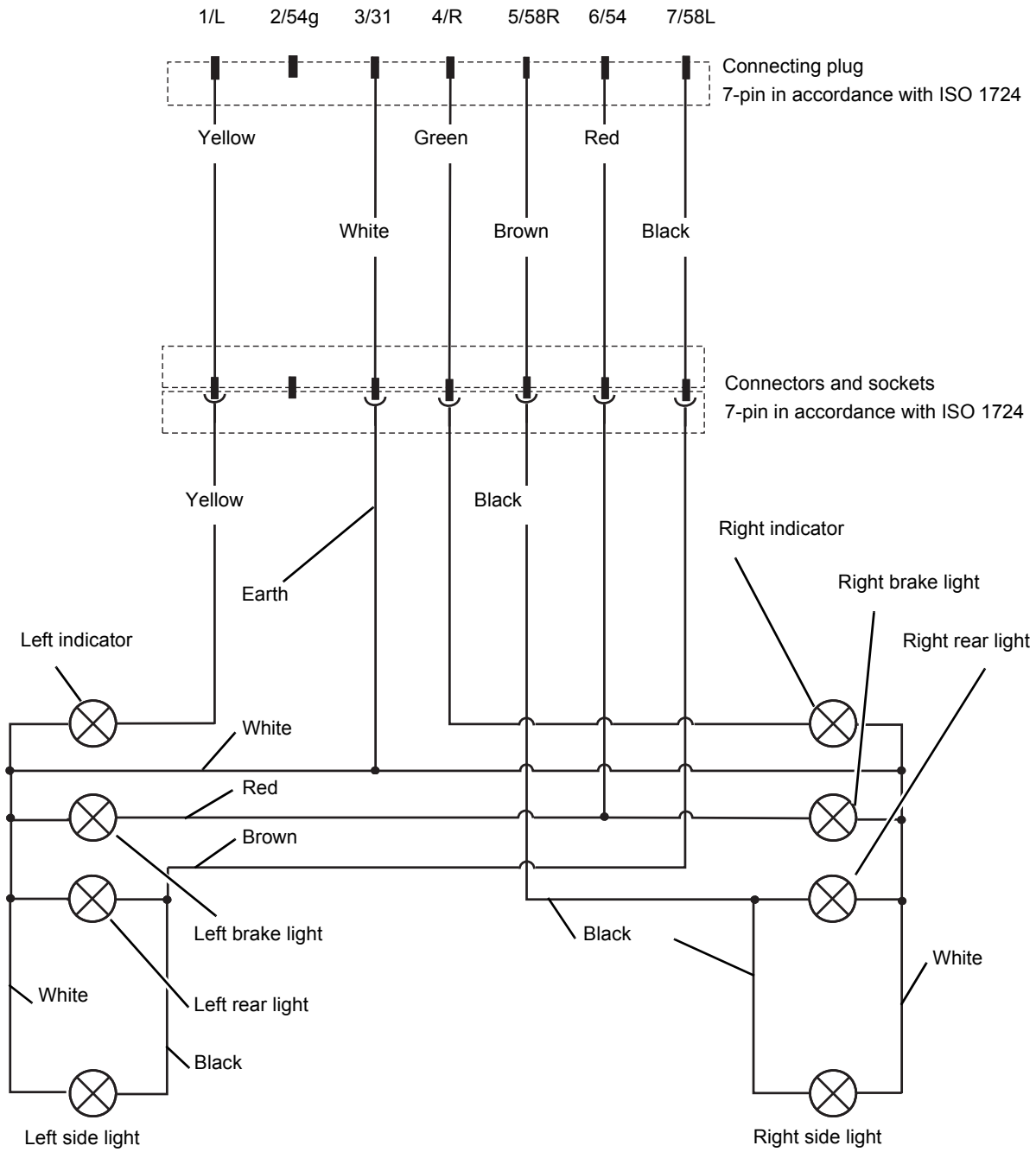

Environment

During decommissioning, the individual parts must be disposed of properly and in an environmentally friendly manner. Please observe the waste disposal guidelines that are currently in force.

Plastic parts

Plastic parts can be disposed of in normal household waste (residual waste), depending on the laws specific to your country.

Metal parts

All metal parts can be sent for recycling.

Oil

In terms of waste legislation, environmentally-compatible hydraulic oils must be stored, collected and disposed of separately in accordance with regulations.

Rubber

Rubber parts, such as hoses or tyres, must be brought to a rubber recycling centre.

EC Declaration of Conformity

**Conforms to
EC Directive
2006/42/EC**

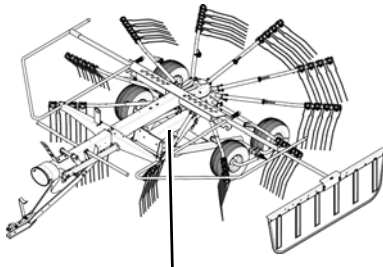

Type plate and CE marking

We

**Kverneland Group Kerteminde AS
Taarpstrandvej 25
DK-5300 Kerteminde
Denmark**

declare with sole responsibility that the product

**Andex 424 T
9442 T
RA 1042 T
and its accessories**

Model: 6598

**Valid from machine number:
VF65982451 –**

to which this declaration relates, comply with the relevant basic health and safety requirements of EC Directive 2006/42/EC.

To demonstrate our compliance with the health and safety requirements quoted in the EC Directive, we make reference to the following standards:

- DIN EN ISO 12 100:2010
- DIN EN ISO 4254-1:2009 + AC:2010
- DIN EN ISO 4254-10:2009 + AC:2010
- DIN 11001-3:1998

Kverneland Group Kerteminde AS
Kerteminde, 11.06.2013

A handwritten signature in black ink, appearing to read 'Uwe Kellermeier'.

Uwe Kellermeier

EC authorised representative

EC Declaration of Conformity

T

Target group	4
Technical specifications	
Dimensions in transport position	22
Dimensions in work position	23
Machine equipment	25
Tractor equipment	24
Weights	24
Tightening torques	
Screwed connections	66
Spring tines	65
Wheel nuts	65
Tractors with quick-release couplings	30
Tractors without quick-release coupling	31
Tyres	69
Tyre pressure	69