

### Cascade® Models

#### Standards

- Meet CSA 22.2 construction standards
- Meet or exceed NRCan energy efficiency standards

#### Benefits

- Bottom cold water entry resulting 10% more hot water
- High-quality magnesium anode
- Low density bolt-on immersion elements
- Coating of blue cobalt glass enriched with zircon to protect the inner tank against corrosion and perforation.
- Secure drain valve for easy drainage
- Factory-installed 3/4" NPT dielectric connections
- Factory-installed heat traps help reduce hot water migration, thus limiting heat loss
- Safety valve protects the tank against the damaging effects of excess temperature and pressure

- Automatic temperature control with adjustable thermostats
- Uniform thickness of insulating foam keeps water warmer for longer periods

#### Warranty

- 8-year warranty against inner tank leakage
- 5-year warranty on parts



Illustrated model: 152B-3F7M

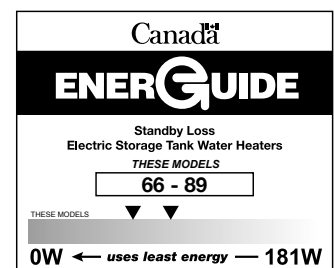

### Cascade® Models

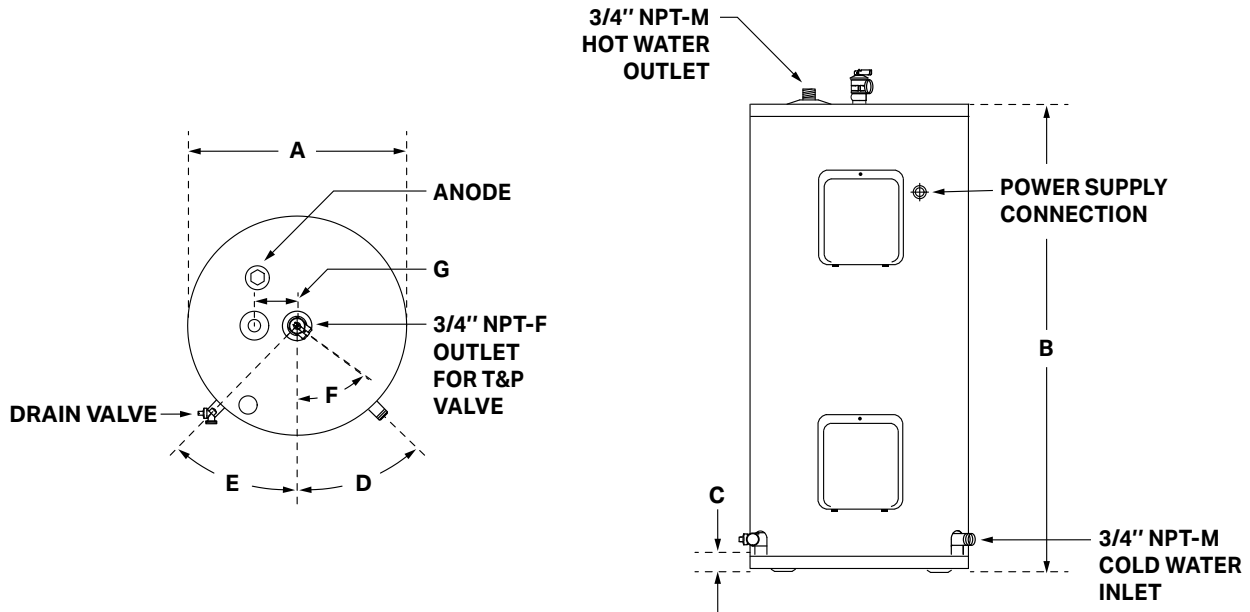

#### SPECIFICATIONS

Model	Storage Capacity			Input watts	Voltage volts	Standby loss watts	Plumbing connections	Waranty Tank / Parts years
	US gal.	liters	IMP gal.					
152B-1F7M	49	184	41	1,500	120	66	3/4" NPT	8 / 5
152B-2F7M	49	184	41	3,000	208	66	3/4" NPT	8 / 5
152B-3F7M	49	184	41	3,000	240	66	3/4" NPT	8 / 5
172B-2F7M	74	279	61	4,500	208	89	3/4" NPT	8 / 5
172B-3F7M	74	279	61	4,500	240	89	3/4" NPT	8 / 5

#### DIMENSIONS

Model	A	B	C	D	E	F	G	Estimated shipping weight lb (kg)
	in (cm)	in (cm)	in (cm)				in (cm)	
152B	22 (56)	49 1/4 (125)	2 1/2 (6)	45°	45°	52°	4 (10)	140 (64)
172B	24 (61)	59 7/8 (152)	2 1/2 (6)	45°	45°	52°	4 (10)	185 (84)