

### Cascade Models

#### Standards

- Meet CSA 22.2 construction standards
- Meet or exceed NRCan energy efficiency standards

#### Benefits

- Bottom cold water entry resulting 10% more hot water
- High-quality magnesium anode
- Low density bolt-on immersion elements
- Coating of blue cobalt glass enriched with zircon to protect the inner tank against corrosion and perforation.
- Secure drain valve for easy drainage
- Factory-installed 3/4" NPT dielectric connections
- Factory-installed heat traps help reduce hot water migration, thus limiting heat loss
- Safety valve protects the tank against the damaging effects of excess temperature and pressure

- Automatic temperature control with adjustable thermostats
- Uniform thickness of insulating foam keeps water warmer for longer periods

#### Warranty

- 8-year warranty against inner tank leakage
- 5-year warranty on parts



Illustrated model: 152B-3F7M

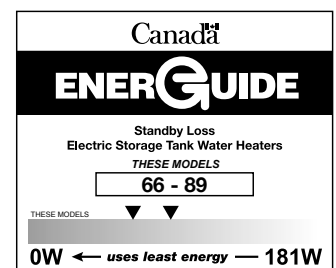

### Cascade Models

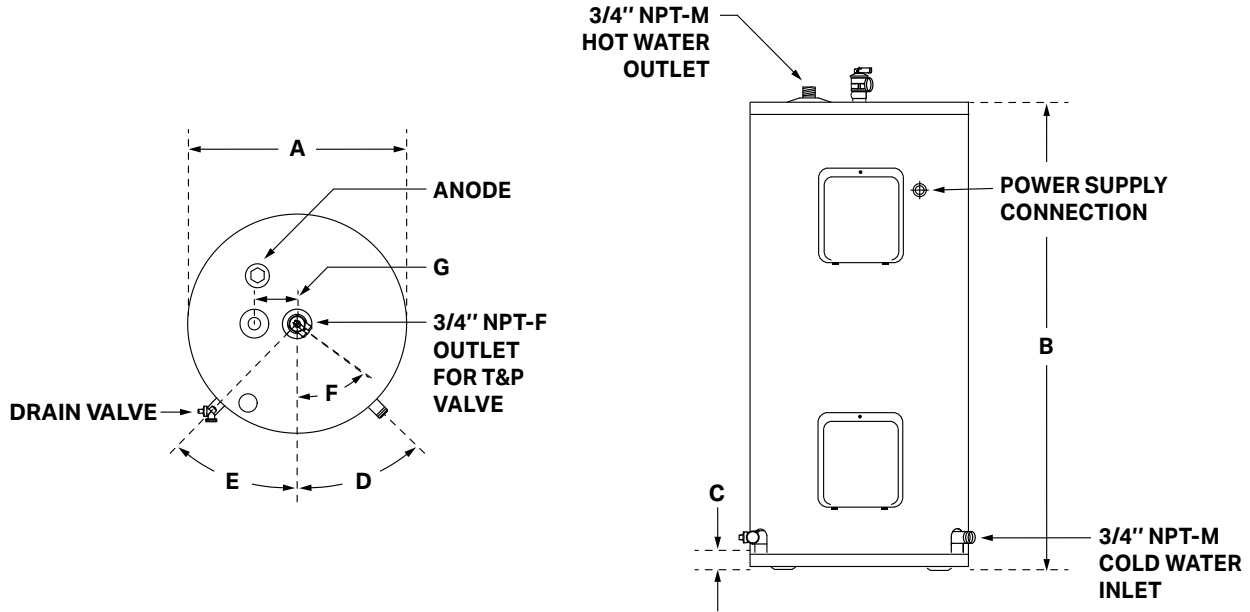

#### SPECIFICATIONS

| Model     | Storage Capacity |        |          | Input<br>watts | Voltage<br>volts | Standby loss<br>watts | Plumbing<br>connections | Waranty<br>Tank / Parts<br>years |
|-----------|------------------|--------|----------|----------------|------------------|-----------------------|-------------------------|----------------------------------|
|           | US gal.          | liters | IMP gal. |                |                  |                       |                         |                                  |
| 152B-1F7M | 49               | 184    | 41       | 1,500          | 120              | 66                    | 3/4" NPT                | 8 / 5                            |
| 152B-2F7M | 49               | 184    | 41       | 3,000          | 208              | 66                    | 3/4" NPT                | 8 / 5                            |
| 152B-3F7M | 49               | 184    | 41       | 3,000          | 240              | 66                    | 3/4" NPT                | 8 / 5                            |
| 172B-2F7M | 74               | 279    | 61       | 4,500          | 208              | 89                    | 3/4" NPT                | 8 / 5                            |
| 172B-3F7M | 74               | 279    | 61       | 4,500          | 240              | 89                    | 3/4" NPT                | 8 / 5                            |

#### DIMENSIONS

| Model | A       | B            | C         | D   | E   | F   | G       | Estimated<br>shipping weight<br>lb (kg) |
|-------|---------|--------------|-----------|-----|-----|-----|---------|---|
|       | in (cm) | in (cm)      | in (cm)   |     |     |     | in (cm) |   |
| 152B  | 22 (56) | 49 1/4 (125) | 2 1/2 (6) | 45° | 45° | 52° | 4 (10)  | 140 (64)                                |
| 172B  | 24 (61) | 59 7/8 (152) | 2 1/2 (6) | 45° | 45° | 52° | 4 (10)  | 185 (84)                                |