

Flexible Models - 105 (40 Imp. gallons)

Standards

- These models meet the safety and construction requirements of CSA Standard C22.2 No. 110
- Meet or exceed the standby loss requirements of NRCAN and ASHRAE 90.1 Standard

Benefits

- **COMMERCIAL DESIGN:** Manufactured with thicker special steel and works so as to feed the elements or a bank of elements alternately and not simultaneously
- Insulated with a uniform 2 inch (5 cm) layer of insulation reducing heat loss and energy costs
- Two (2) oversized high quality magnesium anodes to provide superior protection against the corrosive effects of water and extend the life of the tank
- Conveniently located handhole to help clean and remove sediment accumulation inside the water heater
- Inner tank is glass-lined with a uniquely formulated blue cobalt glass enriched with zircon
- 1-1/2" hot and cold water NPT di-electric connections on all models

- Increased ease of voltage and power conversion on site
- **CONVERSION KIT :** Light and medium duty: allows more than 90 different configurations. Heavy duty: allows more than 343 different configurations.
- T&P valve(supplied) to protect the tank from damaging effects of excessive temperature and pressure (factory installed on 112 models)
- Equipped with two hinged doors for easy service access to components
- Brass drain valve
- Surface mount thermostat at 160°F
- CSA certified immersion heating elements
- Patented twist-lock flange for easier element replacement

Warranty

- 3-year warranty against inner tank leakage
- 1-year warranty on parts



Flexible Models - 105 (40 Imp. gallons)

Light & Medium Duty - 208, 240 & 480 Volts / Single-Phase

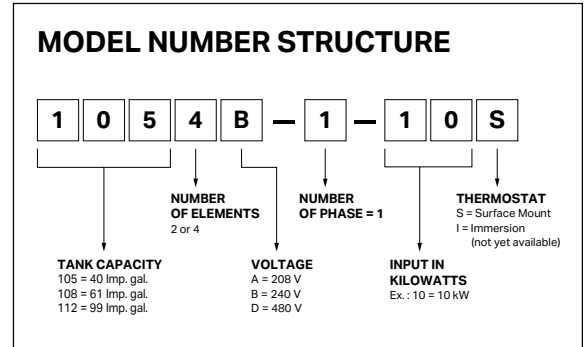
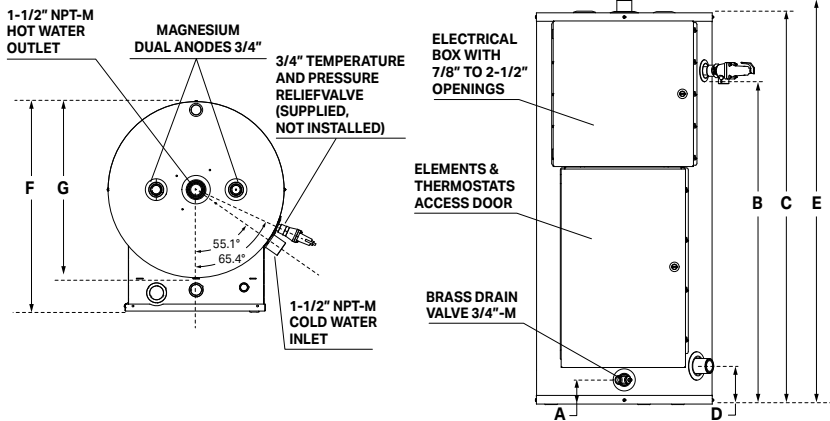

VOLTAGE INDEX	
A	208 Volts
B	240 Volts
D	480 Volts

SPECIFICATIONS						
Model*	Input	Amperage			Phase	Number of elements
	kW	208 V	240 V	480 V		
LIGHT & MEDIUM DUTY - 2 or 4 elements						
1052Y-1-3S	3	14.4	12.5	6.3	1	2
1052Y-1-4.5S	4.5	21.6	18.8	9.4		
1052Y-1-5S	5	24.0	20.8	10.4		
1052Y-1-6S	6	-	25.0	12.5		
1054Y-1-6S	6	28.8	25.0	12.5		4
1054Y-1-9S	9	43.3	37.5	18.8		
1054Y-1-10S	10	48.1	41.7	20.8		
1054Y-1-12S	12	-	50.0	25.0		

* Replace the "Y" by the letter referring to its voltage (refer to the following "Voltage index" as well as the "Model Number Structure" for further details).

CAPACITY & DIMENSIONS											
Model	Storage Capacity			A	B	C	D	E	F	G	Est. Shipping Weight
	IMP gal.	Liters	US gal.	inches (cm)	inches (cm)	inches (cm)	inches (cm)	inches (cm)	inches (cm)	inches (cm)	
All 105	40	184	49	3 1/8 (7.9)	40 3/16 (102.1)	49 1/8 (124.8)	4 7/8 (12.4)	50 3/4 (129)	26 1/4 (66.7)	22 (55.9)	230 (104)

Flexible Models - 105 (40 Imp. gallons)

Heavy Duty - 208, 240 & 480 Volts

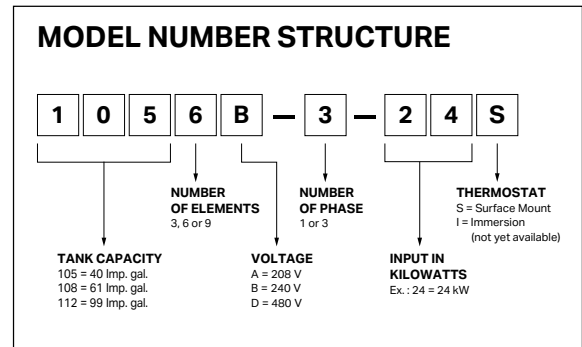
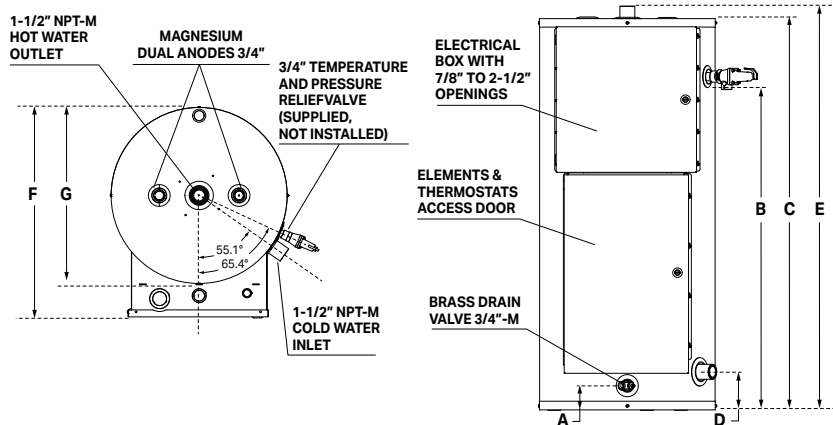

VOLTAGE INDEX

A	208 Volts
B	240 Volts
D	480 Volts

SPECIFICATIONS

Model*	Input kW	Amperage			Phase	Number of elements
		208 V	240 V	480 V		
HEAVY DUTY - 3, 6 or 9 elements						
1053Y-1-6S	6	28.8	25.0	12.5	1	3
1053Y-3-6S		16.7	14.7	7.2	3	
1053Y-1-9S		43.3	37.5	18.8	1	
1053Y-3-9S	9	25.0	21.7	10.8	3	
1053Y-1-12S	12	57.7	50.0	25.0	1	
1053Y-3-12S		33.3	28.9	14.4	3	
1053Y-1-13.5S		64.9	56.3	28.1	1	
1053Y-3-13.5S	13.5	37.5	32.5	16.2	3	
1053Y-1-15S	15	72.1	62.5	31.3	1	
1053Y-3-15S		41.6	36.1	18.0	3	
105XY-1-18S		18	86.5†	75.0	37.5	1
105XY-3-18S	50.0†	43.3	21.7	3	3 or 6	
1056Y-1-24S	24	115.4	100.0	50.0	1	6
1056Y-3-24S		66.6	57.7	28.9	3	
1056Y-1-27S		129.8	112.5	56.3	1	
1056Y-3-27S	27	74.9	65.0	32.5	3	
1056Y-1-30S	30	144.2	125.0	62.5	1	
1056Y-3-30S		83.3	72.2	36.1	3	
105XY-1-36S		36	173.1††	150.0	75.0	
105XY-3-36S	99.9††	86.6	43.3	3	6 or 9	
1059Y-1-40.5S	40.5	194.7	168.8	84.4	1	
1059Y-3-40.5S		112.4	97.4	48.7	3	
1059Y-1-45S		216.3	187.5	93.8	1	
1059Y-3-45S	45	124.9	108.3	54.1	3	
1059Y-1-54S	54	—	255.0	112.5	1	
1059Y-3-54S		—	129.9	65.0	3	

* Replace the "X" in the model number by the element quantity shown in the "Number of elements" column as well as the "Y" by the letter referring to its voltage (refer to the following "Voltage index" as well as the "Model Number Structure" for further details).

† For 208 V Models with a 18 kW input, only the 6-element configuration is possible.

†† For 208 V Models with a 36kW input, only the 9-element configuration is possible.

CAPACITY & DIMENSIONS

Model	Storage Capacity			A	B	C	D	E	F	G	Est. Shipping Weight lb (kg)
	IMP gal.	Liters	US gal.	inches (cm)	inches (cm)	inches (cm)	inches (cm)	inches (cm)	inches (cm)	inches (cm)	
All 105	40	184	49	3 1/8 (7.9)	40 3/8 (102.1)	49 1/8 (124.8)	4 7/8 (12.4)	50 3/4 (129)	26 1/4 (66.7)	22 (55.9)	230 (104)

Flexible Models - 105 (40 Imp. gallons)

Heavy Duty - 600V / Three-Phase

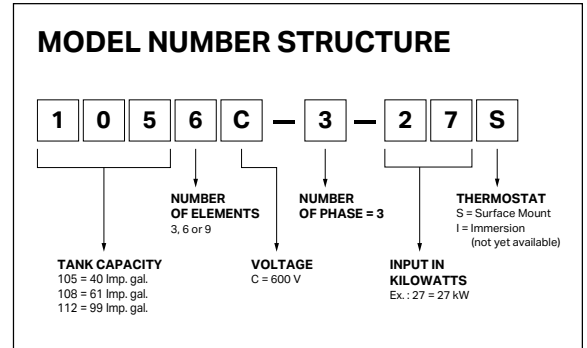
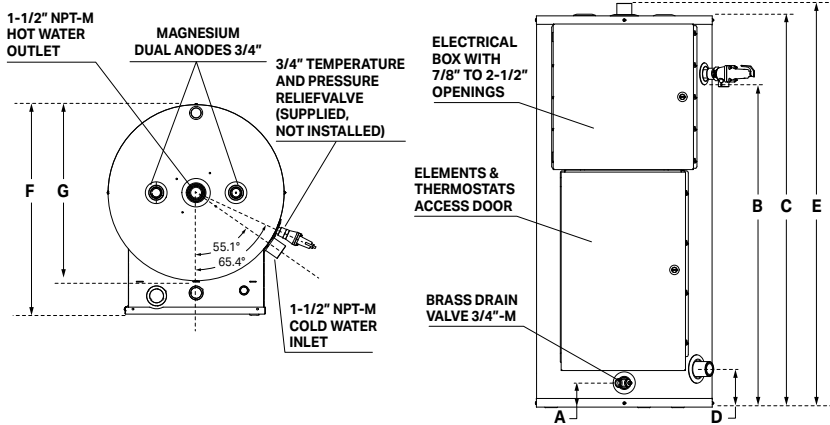

VOLTAGE INDEX	
C	600 Volts

SPECIFICATIONS				
Model	Input		Number of elements	Amperage
	kW			
HEAVY DUTY - 600V				
1053C-3-6S	6		3	5.8
1053C-3-9S	9			8.7
1053C-3-12S	12			11.5
1053C-3-13.5S	13.5			13.0
1053C-3-15S	15			14.4
1053C-3-18S	18			17.3
1056C-3-18S	18			6
1056C-3-24S	24		23.1	
1056C-3-27S	27		26.0	
1056C-3-30S	30		28.9	
1056C-3-36S	36		34.6	
1059C-3-36S	36		34.6	
1059C-3-40.5S	40.5		9	
1059C-3-45S	45			43.3
1059C-3-54S	54			52.0

CAPACITY & DIMENSIONS											
Model	Storage Capacity			A	B	C	D	E	F	G	Est. Shipping Weight
	IMP gal.	Liters	US gal.								
All 105	40	184	49	3 7/8 (7.9)	40 3/16 (102.1)	49 1/8 (124.8)	4 7/8 (12.4)	50 3/4 (129)	26 1/4 (66.7)	22 (55.9)	230 (104)