

### 1000-ISO / 1100-ISO Models

Giant's commercial storage tanks are built to be used as an additional support for your hot water storage needs.

#### Standards

- This model meets all safety and construction requirements of UL Standard 1453

#### Benefits

- Designed to be used in conjunction with our traditional water heaters or any other water heating equipment such as boilers, booster tanks, etc.
- Can handle multiple demands for hot water in different locations simultaneously
- Inner tank is glass-lined with a uniquely formulated blue cobalt glass enriched with zircon
- Equipped with two (2) oversized magnesium anode rods. They provide excellent protection against the corrosive effects of water and extends tank life
- Front and rear water connections included on the storage tanks are designed for flexible installation and easy coupling of the recirculation system. Factory installed on insulated models and supplied on non-insulated models

- Supplied T&P relief valve protects the tank from the damaging effects of excessive temperature and pressure. *Note: For safety purposes, a temperature and pressure-relief valve MUST be installed on all Giant storage tanks*
- A high quality and tamper resistant one-piece brass drain valve is installed on insulated models for easy drainage
- Handhole conveniently located to help clean and remove sediment accumulation inside the water heater. Standard on all models

#### Warranty

- 5-year warranty against inner tank leakage
- 1-year warranty on parts



### 1000-ISO / 1100-ISO Models

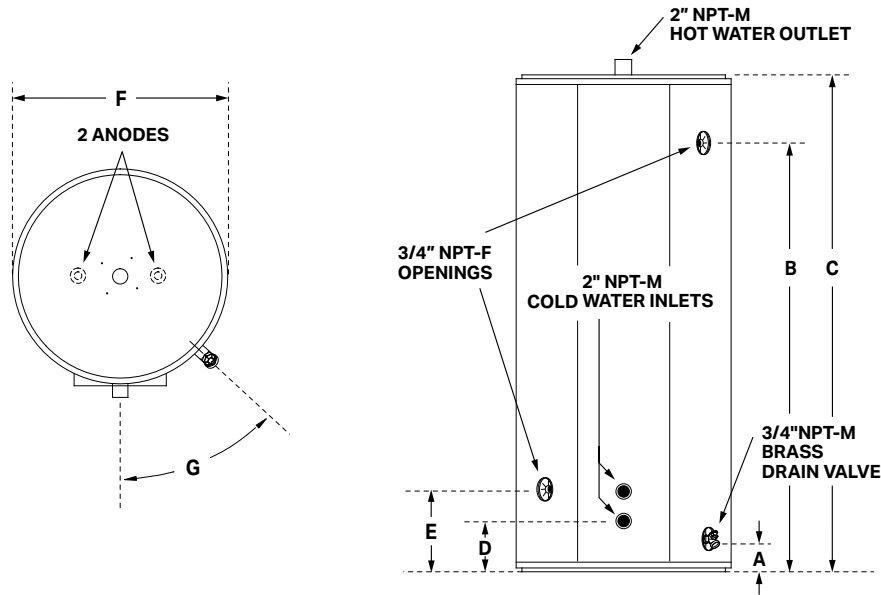

CAPACITY & DIMENSIONS										Est. Shipping Weight lb (kg)	
Model	Storage Capacity			A	B	C	D	E	F		G
	US gal.	Liters	IMP gal.	inches (cm)	inches (cm)	inches (cm)	inches (cm)	inches (cm)	inches (cm)		
1000-ISO	96	364	80	3 3/4 (10)	45 3/4 (116)	55 1/4 (140)	6 5/8 (17)	10 5/8 (129)	28 1/4 (72)	47°	370 (168)
1100-ISO	120	455	100	3 (8)	58 (147)	67 5/16 (171)	6 1/2 (17)	10 1/2 (27)	28 1/4 (72)	46.8°	415 (188)