

Master-Fit™

FULLY TESTED FOR SAFETY AND PERFORMANCE

- Design certified by Underwriters Laboratories for 180°F (82°C) hot water service
- Certified for use on combustible flooring
- 80% thermal efficiency

FULLY AUTOMATIC CONTROLS WITH SAFETY SHUTOFF

- Accurate, dependable control system
- Manual reset gas shutoff device for added safety
- Maximum inlet gas pressure is 13.8" w.c. for natural gas and propane, and minimum gas pressure is 4.5" w.c. for natural gas and 11" w.c. for propane

WATER CONNECTIONS

- For ease of installation, most models feature water connections on the top, front, and rear

GLASS-LINED TANK

- PermaGlas® Ultra Coat™ is the proprietary liquid glass coating developed by A. O. Smith
- Applied after tank construction, the tank is mechanically maneuvered to ensure the liquid glass covers all surfaces for superior protection

Eliminator™ SELF CLEANING DEVICE DIRECTS INCOMING COLD WATER TO SWEEP THE BOTTOM OF THE TANK SO SEDIMENT DOES NOT ACCUMULATE

FOAM INSULATION SAVES FUEL AND HELPS REDUCE STANDBY HEAT LOSS

HEAVY GAUGE STEEL JACKET WITH BAKED ENAMEL FINISH OVER A BONDERIZED UNDERCOAT

HANDHOLE CLEANOUT ALLOWS FOR EASY CLEANING

INTERMITTENT IGNITION DEVICE

- Eliminates standing pilot
- Provides flame failure response in less than one second
- Power ON/OFF switch

EASY-TO-INSTALL

- Completely factory-assembled - only gas, water, vent and electric connections need be made
- Provided with drain valve

FACTORY-INSTALLED AND TESTED DRAFT DIVERTER

- Low-profile draft hood with automatic motorized flue damper to minimize standby losses

CoreGard™ LONG-LIFE, STAINLESS STEEL CORE ANODE RODS

COMPLIANCE

- All models comply with ANSI Z21.10.3 – CSA 4.3 standard, meet NRCAN thermal efficiency and standby loss requirements for **replacement units (only)**, and current edition of ASHRAE/IESNA 90.1

OTHER FEATURES

- Equipped with gas pressure regulator and pilot filter
- Integral automatic gas shutoff system prevents excessive water temperature
- CSA Certified and ASME Rated T&P relief valve
- Maximum working pressure is 160 psi (1103 kPa) standard
- Adjustable thermostat with a 120-180°F (49°C-82°C) range

OPTIONS

- Power vent kits for side wall venting (see back page for details)
- Meets NSF Standard 5 with optional leg kit (part number 9003425205)

WARRANTY

- 3 year limited tank warranty
- 1 year limited parts warranty
- For complete information, consult the written warranty or A. O. Smith

BTRC 120-400A

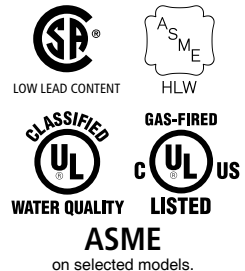

Approved to NSF Standard 5
with Optional Leg Kit

ROUGH-IN DIMENSIONS - SIDE VIEW Models BTRC 120-400A

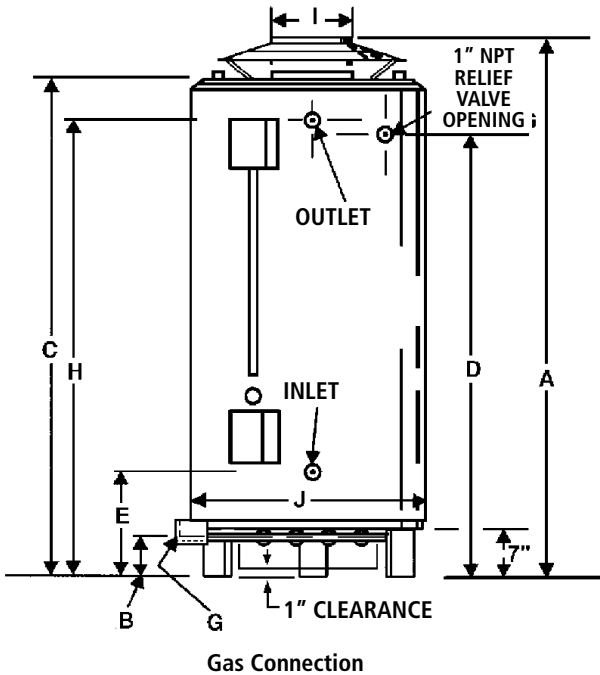

MODEL	CLEARANCE TO COMBUSTIBLES		CLEARANCE TO NON-COMBUSTIBLES	
	SIDES & REAR	TOP COVER	SIDES & REAR	TOP COVER
BTRC-120	1" (2.54 cm)	12" (30.48 cm)	0" (0 cm)	12" (30.48 cm)
BTRC-154	1" (2.54 cm)	12" (30.48 cm)	0" (0 cm)	12" (30.48 cm)
BTRC-180	1" (2.54 cm)	12" (30.48 cm)	0" (0 cm)	12" (30.48 cm)
BTRC-197	1" (2.54 cm)	12" (30.48 cm)	0" (0 cm)	12" (30.48 cm)
BTRC-199	1" (2.54 cm)	12" (30.48 cm)	0" (0 cm)	12" (30.48 cm)
BTRC-200A	1" (2.54 cm)	12" (30.48 cm)	0" (0 cm)	12" (30.48 cm)
BTRC-250A	2" (5.08 cm)	12" (30.48 cm)	0" (0 cm)	12" (30.48 cm)
BTRC-251(A)	2" (5.08 cm)	12" (30.48 cm)	0" (0 cm)	12" (30.48 cm)
BTRC-275A	2" (5.08 cm)	12" (30.48 cm)	0" (0 cm)	12" (30.48 cm)
BTRC-305(A)	2" (5.08 cm)	12" (30.48 cm)	0" (0 cm)	12" (30.48 cm)
BTRC-365(A)	4" (10.16 cm)	4" (10.16 cm)	4" (10.16 cm)	12" (30.48 cm)
BTRC-400A	3" (7.62 cm)	12" (30.48 cm)	0" (0 cm)	12" (30.48 cm)

Top View of BTRC

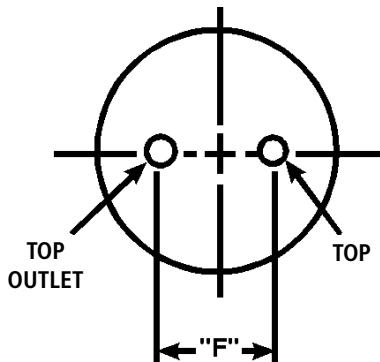

MODEL	WATER CONNECTIONS IN INCHES (NPT)					
	INLET			OUTLET		
	TOP	FRONT	REAR	TOP	FRONT	REAR
BTRC-120	1.5"	1.5"	1.5"	1.5"	1.5"	1.5"
BTRC-154	1.5"	1.5"	1.5"	1.5"	1.5"	1.5"
BTRC-180	1.5"	1.5"	1.5"	1.5"	1.5"	1.5"
BTRC-197	1.5"	1.5"	1.5"	1.5"	1.5"	1.5"
BTRC-199	1.5"	1.5"	1.5"	1.5"	1.5"	1.5"
BTRC-200A	1.5"	2"	2"	1.5"	2"	2"
BTRC-250A	1.5"	2"	2"	1.5"	2"	2"
BTRC-251(A)	N/A	1.5"	1.5"	N/A	1.5"	1.5"
BTRC-275A	1.5"	2"	2"	1.5"	2"	2"
BTRC-305(A)	N/A	1.5"	2"	N/A	2"	1.5"
BTRC-365(A)	N/A	1.5"	1.5"	N/A	1.5"	1.5"
BTRC-400A	1.5"	2"	2"	1.5"	2"	2"

	GAS PRESSURE REQUIREMENTS	
	NATURAL GAS	PROPANE GAS
Max. Supply Pressure	13.8" w.c.	13.8" w.c.
Min. Supply Pressure	4.5" w.c.	11" w.c.
Manifold Pressure	3.5" w.c.	10" w.c.

	ELECTRICAL SPECIFICATIONS	
	VOLTS	AMPS
BTRC	120VAC	.7
BTRC with Power Venter	120VAC	3.0 FLA



Commercial Gas Water Heaters

DIMENSION TABLES FOR BTRC MODELS 120-400A

MODEL	INPUT RATING		CAPACITY USG (L)	A IN (CM)	B IN (CM)	C IN (CM)	D IN (CM)	E IN (CM)	F IN (CM)	G IN	H IN (CM)	I IN (CM)	J IN (CM)	SHIPPING WEIGHT LB (KG)	
	BTU/h	kW/h												STD.	ASME
BTRC-120	120,000	35	71 (268)	69 3/4 (177)	4 1/4 (11)	59 1/2 (151)	50 7/8 (129)	19 3/4 (50)	19 (48)	1/2	51 7/8 (132)	5 (13)	27 3/4 (71)	512 (232)	N/A
BTRC-154	154,000	45	81 (307)	73 (185)	4 1/4 (11)	66 1/2 (169)	57 7/8 (147)	19 3/4 (50)	19 (48)	1/2	59 (150)	6 (15)	27 3/4 (71)	552 (250)	N/A
BTRC-180	180,000	53	76 (288)	67 1/2 (171)	4 1/2 (12)	62 (157)	53 3/8 (136)	20 1/2 (52)	21 (53)	1/2	54 3/8 (139)	6 (15)	27 3/4 (71)	576 (261)	N/A
BTRC-197	199,000	58	95 (360)	75 (191)	4 1/2 (12)	70 (178)	61 3/8 (157)	20 1/2 (52)	21 (53)	1/2	62 3/8 (159)	6 (15)	27 3/4 (71)	645 (293)	N/A
BTRC-199	199,000	58	76 (288)	67 1/2 (171)	4 1/2 (12)	62 (157)	53 3/8 (136)	20 1/2 (52)	21 (53)	1/2	54 3/8 (139)	6 (15)	27 3/4 (71)	592 (269)	N/A
BTRC-200A	199,000	58	100 (379)	72 (183)	4 1/2 (12)	65 1/8 (165)	55 7/8 (142)	19 3/4 (50)	23 (58)	1/2	56 3/8 (143)	6 (15)	30 1/4 (77)	N/A	715 (324)
BTRC-250A	250,000	72	100 (379)	72 (183)	4 1/2 (12)	65 1/8 (165)	55 7/8 (142)	19 3/4 (50)	23 (58)	1/2	56 3/8 (143)	8 (20)	30 1/4 (77)	N/A	715 (324)
BTRC-251(A)	251,000	73	65 (246)	75 (191)	4 1/2 (12)	65 3/4 (167)	57 1/4 (145)	20 (51)	N/A	1/2	58 3/4 (149)	8 (20)	27 3/4 (71)	660 (299)	661 (300)
BTRC-275A	275,000	80	100 (379)	72 (183)	4 1/2 (12)	65 1/8 (165)	55 7/8 (142)	19 3/4 (50)	23 (58)	1/2	56 3/8 (143)	8 (20)	30 1/4 (77)	N/A	721 (327)
BTRC-305(A)	305,000	89	65 (246)	75 (191)	4 1/2 (12)	65 3/4 (167)	57 1/4 (145)	20 (51)	N/A	1/2	58 3/4 (149)	8 (20)	27 3/4 (71)	659 (299)	672 (305)
BTRC-365(A)	360,000	105	65 (246)	75 (191)	4 1/2 (12)	65 3/4 (167)	57 1/4 (145)	20 (51)	N/A	3/4	58 3/4 (149)	8 (20)	27 3/4 (71)	670 (304)	661 (300)
BTRC-400A	390,000	117	100 (379)	75 1/2 (192)	4 1/2 (12)	67 1/2 (171)	58 1/4 (148)	26 3/4 (68)	23 (58)	3/4	59 (150)	8 (20)	30 1/4 (77)	N/A	844 (383)

*"A" suffix identifies ASME only.

*("A)" suffix identifies optional ASME model available. Contact A. O. Smith Enterprises for dimensions of ASME versions of the BTRC- 251, 305 & 365

Models available in both natural gas and propane, as well as sea level and high altitude.

MODEL	INPUT RATING		CAPACITY USG (L)	THERMAL EFFICIENCY	RECOVERY RATING CAPACITIES GPH (LPH)											
	BTU/h	kW/h			30°F (17°C)	40°F (22°C)	50°F (28°C)	60°F (33°C)	70°F (39°C)	80°F (45°C)	90°F (50°C)	100°F (56°C)	110°F (61°C)	120°F (67°C)	130°F (72°C)	140°F (78°C)
BTRC-120	120,000	35	71 (268)	80%	388 (1469)	291 (1102)	233 (882)	194 (734)	166 (628)	145 (549)	129 (488)	116 (439)	106 (401)	97 (367)	90 (341)	83 (314)
BTRC-154	154,000	45	81 (307)	80%	498 (1885)	373 (1412)	299 (1132)	249 (943)	213 (806)	187 (708)	166 (628)	149 (564)	136 (515)	124 (469)	115 (435)	107 (405)
BTRC-180	180,000	53	76 (288)	80%	579 (2192)	434 (1643)	347 (1314)	289 (1094)	248 (939)	217 (821)	193 (731)	174 (659)	158 (598)	145 (549)	134 (507)	124 (469)
BTRC-197	199,000	58	95 (360)	80%	643 (2434)	482 (1825)	386 (1461)	322 (1219)	276 (1045)	241 (912)	214 (810)	193 (731)	175 (662)	161 (609)	148 (560)	132 (500)
BTRC-199	199,000	58	76 (288)	80%	643 (2434)	482 (1825)	386 (1461)	322 (1219)	276 (1045)	241 (912)	214 (810)	193 (731)	175 (662)	161 (609)	148 (560)	132 (500)
BTRC-200A	199,000	58	100 (379)	80%	643 (2434)	482 (1825)	386 (1461)	322 (1219)	276 (1045)	241 (912)	214 (810)	193 (731)	175 (662)	161 (609)	148 (560)	132 (500)
BTRC-250A	250,000	72	100 (379)	80%	808 (3059)	606 (2294)	485 (1836)	404 (1529)	346 (1310)	303 (1147)	269 (1018)	242 (916)	220 (833)	202 (765)	186 (704)	173 (655)
BTRC-251(A)	251,000	73	65 (246)	80%	811 (3070)	608 (2301)	487 (1843)	406 (1537)	348 (1317)	304 (1151)	270 (1022)	243 (920)	221 (837)	203 (768)	187 (708)	174 (659)
BTRC-275A	275,000	80	100 (379)	80%	889 (3365)	667 (2525)	533 (2018)	444 (1681)	381 (1442)	333 (1261)	296 (1120)	267 (1011)	242 (916)	222 (840)	205 (776)	190 (719)
BTRC-305(A)	305,000	89	65 (246)	80%	986 (3732)	739 (2797)	592 (2241)	493 (1866)	423 (1601)	370 (1401)	329 (1245)	296 (1120)	269 (1018)	246 (931)	228 (863)	211 (799)
BTRC-365(A)	360,000	105	65 (246)	80%	1164 (4406)	873 (3304)	698 (2642)	582 (2203)	499 (1888)	436 (1650)	388 (1468)	349 (1321)	317 (1199)	291 (1105)	269 (1018)	249 (942)
BTRC-400A	390,000	117	100 (379)	80%	1290 (4883)	967 (3660)	774 (2930)	645 (2442)	553 (2093)	484 (1832)	430 (1628)	387 (1465)	352 (1332)	322 (1219)	298 (1128)	276 (1045)

POWER VENT KITS FOR BTRC

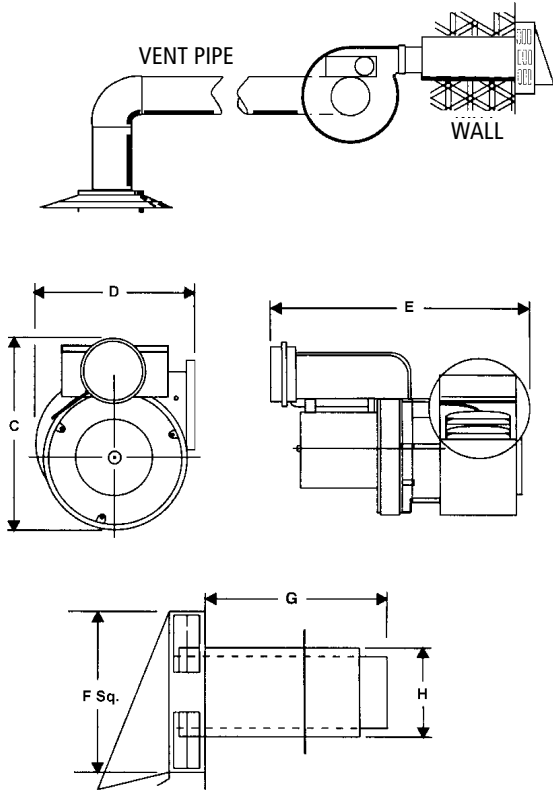

FEATURES

DESIGNED FOR FLEXIBILITY - Easy to install sidewall power vent system. Use these kits where gas is the preferred choice, but conventional venting is costly. Allows conversion from electric to gas or upgrading to units with higher inputs without having to do costly venting system upgrades. Easy to install and wire. Approved for use on all A. O. Smith water heaters listed below. Allows the use of smaller diameter vent pipe than allowed with conventional venting.

POWERFUL 115 VOLT POWER VENTER - Allows venting up to 100 (30.48m) equivalent feet away. Each model sized for a perfect match with A. O. Smith water heaters. Power Venters have one or more of the following depending on the heater's requirements. Built in 24/115 volt relay to interface with control systems. Combination 24 volt relay and adjustable post-purge timer control in lieu of relay on some models. Installed diaphragm draft proving switch. Vibration isolation mount works with common plumber's strap and helps keep operation quiet. All controls factory mounted and wired for simple installation.

ALUMINUM VENT HOOD - Mounts on outside of wall. Features telescoping vent pipe connection sleeve, rust free construction, outside wall condensate shield, 1" air space provides clearance for combustibles, special heat shield protects building exterior. Mounting hardware included.

COLOUR CODED WIRING HARNESS - Eliminates need for electrician (check codes). Simple 24 volt connections and a 40 ft. (12.2m) low voltage cable.

MODEL	PART NUMBER	MOTOR WATT	MOTOR AMPS	MAX LENGTH OF VENT FT (M)	VENT DIAMETER SIZE IN (CM)	DIMENSIONS IN (CM)						
						C VENT ASSEMBLY HEIGHT	D VENT ASSEMBLY DEPTH	E VENT ASSEMBLY WIDTH	F VENT TERMINATION SQUARE	G	H	ROUGH IN
BTRC-120-200A	100054906	95	1.26	100 (30.48)	4 (10.1)	7 7/8 (20)	7 (17.7)	11 (27.9)	9 (22.9)	8 7/8 (22.5)	7 1/2 sq. (19.1)	8 sq. (20.3)
BTRC-250A - 400A	100054907	224	2.0	100 (30.48)	6 (15.2)	9 1/4 (23.5)	8 1/2 (21.6)	11 1/2 (29.2)	10 1/8 (25.7)	9 1/2 (24.1)	8 1/2 dia. (21.6)	9 dia (22.9)

* Vent pipe/vent hood connection based on Class B vent pipe sizes. Calculated using total pipe length, plus 5 ft. (1.524m) for every 90° elbow and 2 1/2 ft. (0.762m) for every 45° elbow.

SUGGESTED SPECIFICATION

Water Heater(s) shall be Model _____ as manufactured by A. O. Smith, or equal. Water heater(s) shall be of glass-lined design, and gas-fired, equipped to burn _____ gas and design certified by Underwriters Laboratories under Volume III tests for commercial heaters for delivery of 180°F (82°C) water, and meet or exceed the thermal efficiency and/or standby loss requirements of NRCan and current edition of ASHRAE/IESNA 90.1. Heaters shall have an input rating of _____ and a recovery rating of _____ GPH (LPH) at a temperature rise of 100°F (38°C) with a storage capacity of _____ gallons (liters). Heaters shall be equipped with 1 1/2" (38.1mm) water inlet and outlet openings, a 2 3/4" (69.85mm) x 3 3/4" (95.25mm) boiler-type hand hole clean out and shall have a maximum working pressure of 160 psi (1103.1 kPa). Water heater(s) shall be equipped with an integrated control system consisting of a 180°F (82°C) adjustable thermostat with upper and lower sensing bulbs, which average the water temperatures at the top and bottom of the tank for maximum water temperature control. Heater(s) shall be provided with a manual reset gas shutoff device, a gas pressure regulator set for the type of gas supplied, coated steel burners, an approved draft hood, anodes for cathodic protection, flue damper and IID system. A CSA Certified and ASME Rated T&P relief valve shall be furnished and installed by the factory. The heater shall be insulated with foam insulation or equal. The outer jacket shall have a baked enamel finish over a bonderized undercoating. All internal surfaces of the heater(s) exposed to water shall be glass-lined with an alkaline borosilicate composition that has been fused-to-steel by firing at a temperature range of 1400° (760°C) to 1600°F (871°C). Heater tank shall have a 3-year limited warranty against corrosion or sediment buildup as outlined in the written warranty. Fully illustrated instruction manual to be included.

For Technical Information call 888-599-2837. A. O. Smith Enterprises Ltd. reserves the right to make product changes or improvements without prior notice.