



Giant®

Enhancing everyday living

COMMERCIAL
STORAGE TANKS

| 80 | 99 | 100 | IMP. GALLONS

COMMERCIAL STORAGE TANKS PRODUCT RANGE

Giant's commercial storage tanks are built to be used as an additional support for your hot water storage needs.

During peak periods, increase your hot water availability by combining one of our 80 or 100 imp. gallon capacity storage tanks with a traditional water heater. This way, you will draw a large volume of hot water in a short period of time!

Choose between a bare or a jacketed model, each equipped with multiple water connections for easy installation and flexibility.

Giant's commercial storage tanks are designed to provide the best solution for your business!

NON-INSULATED MODELS



1001 | **1101**
80 IMP Gal. | 100 Imp Gal.

CSB120
99 IMP Gal.

INSULATED MODELS



1100
100 IMP Gal.

CS120
99 IMP Gal.

BENEFITS

1 - APPLICATION

Designed to be used in conjunction with our traditional water heaters or any other water heating equipment such as boilers, booster tanks, etc.

2 - CAPACITY TO SUPPLY

Giant's commercial storage tanks will allow you to get a large volume of hot water, when you need it the most, in a short period of time. Can handle multiple demands for hot water in different locations simultaneously.

3 - INSULATION

CS120 tanks are insulated with a 2" (5 cm) uniform and eco-friendly blanket. This foam's thermal insulation exceeds R13.5. It allows a maximum heat retention and resistance within the storage tank. The water is, thus, kept hotter for a longer period of time, reducing also standby losses and energy costs.

1100 ISO Tanks are insulated with a high density fiber glass that provides favorable heat retention and efficiency while being environmentally friendly.

4 - GLASS-LINED INNER TANK

A uniquely formulated blue cobalt glass enriched with zircon is fused to specially treated steel at 1,600°F (871°C) to provide the best coating available against corrosion for many years. The tank is certified at a test pressure of 300 PSI (2,068 kPa) and a working pressure of 150 PSI (1,034 kPa).

5 - OVERSIZED HIGH QUALITY MAGNESIUM ANODE RODS

Each tank are equipped with two (2) oversized magnesium anode rods. They provide excellent protection against the corrosive effects of water and extends tank life.

6 - STANDARD INSTALLATION

CS120 and CSB120 models can easily replace the most common storage tank models available on the market.

7 - MULTIPLE WATER CONNECTIONS, 2" NPT DI-ELECTRIC NIPPLES

Front and rear water connections included on the storage tanks are designed for flexible installation and easy coupling of the recirculation system. Extends the life of the water heater by providing excellent corrosion protection. Factory installed on insulated models and supplied on non-insulated models.

NB: Commercial ISO models have different hot and cold water connections than the other models. Please refer to the diagram provided for complete details.

8 - SUPPLIED T&P RELIEF VALVE

Protects the tank from the damaging effects of excessive temperature and pressure.

Warning: For safety purposes, a temperature and pressure-relief valve MUST be installed on all Giant storage tanks.

9 - BRASS DRAIN VALVE

A high quality and tamper resistant one-piece brass drain valve is installed on insulated models for easy drainage.

10 - HANDHOLE CLEANOUT

Conveniently located to help clean and remove sediment accumulation inside the water heater. Standard on all models.

11 - HEAVY GAUGE STEEL JACKET

With powder coated paint finish. Offers more benefits than liquid coating by containing no solvents and releasing little to no amount of Volatile Organic Compounds (VOC). This finish also produces much thicker coatings without running or sagging, thus protecting the tank from external corrosive effects.

12 - COMMERCIAL GRADE RED OXIDE PRIMER

Protects the surface of the steel in severely corrosive atmosphere. Gives extra protection against rust under excessive heat and humidity. On non-insulated models.



CS120 | INSULATED

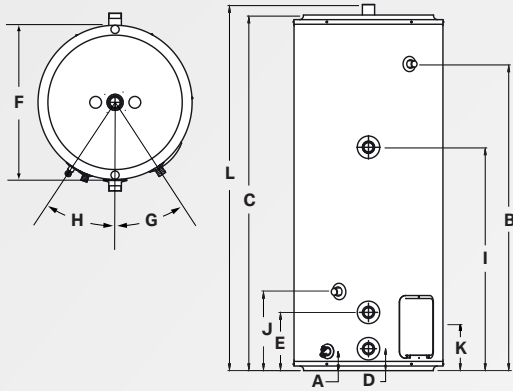

CSB120 | NON-INSULATED

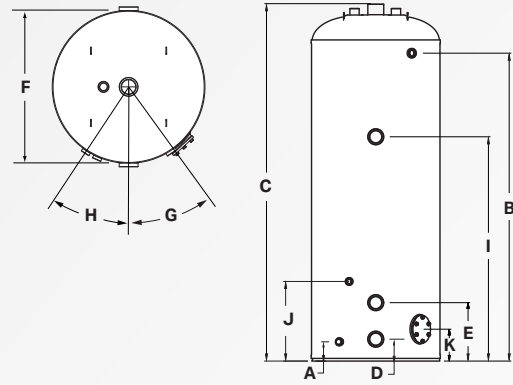

1100 ISO | INSULATED

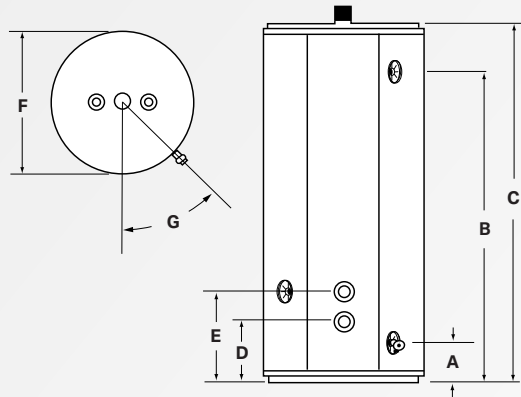

1001 & 1101 | NON-INSULATED

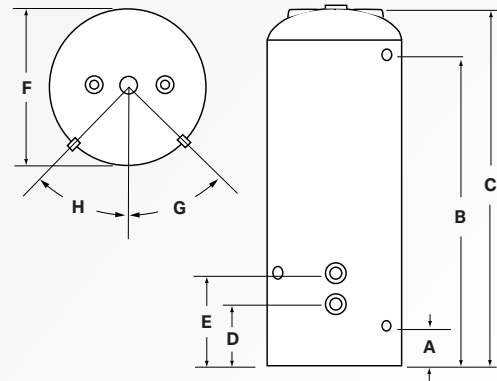

SPECIFICATIONS & DIMENSIONS

Models	Storage Capacity			A	B	C	D	E	F	G	H	I	J	K	L	Est. ship. weight	
	U.S. gal.	Litre	Imp. gal.													inches (cm)	inches (cm)
Insulated Models																	
CS120	119	451	99	2 3/4 (7)	58 (147)	67 1/4 (171)	4 1/4 (11)	11 (28)	28 1/4 (72)	42.5°	23.8°	42 1/4 (107)	15 (38)	6 (15)	69 1/2 (177)	405 (187)	
1100 ISO	120	455	100	3 (8)	58 (147)	67 5/16 (171)	6 1/2 (17)	10 1/2 (27)	28 1/4 (72)	46.8°	—	—	—	—	—	415 (188)	
Non-insulated Models																	
CSB120	119	451	99	3 5/8 (9)	58 (147)	65 3/4 (167)	4 1/8 (10)	11 (28)	24 1/16 (61)	42.8°	33.3°	42 1/4 (107)	15 (38)	6 (15)	—	324 (147)	
1001	96	364	80	3 5/8 (9)	45 7/8 (117)	53 1/2 (136)	6 1/2 (17)	10 1/2 (27)	24 (61)	47°	47°	—	—	—	—	325 (147)	
1101	120	455	100	3 5/8 (9)	57 7/8 (147)	65 1/2 (166)	6 1/2 (17)	10 1/2 (27)	24 (61)	47°	47°	—	—	—	—	370 (168)	

WARRANTY

5 years against inner tank leakage

1 year on component parts

Giant offers a FIVE (5) year basic limited warranty on commercial storage tanks against inner tank leakage from the date of installation and a ONE (1) year basic limited warranty on component parts. For more specific warranty details including exceptions, consult the owner's manual that comes with each storage tank.



11021, Notre-Dame Street East, Montreal-East, Quebec, Canada, H1B 2V5
 Telephone : 514-645-8893 • Toll free : 1-800-363-9354
 General fax : 514-640-0969
 Customer Service fax : 514-645-8413

giantinc.com