

Kit Instructions

COMMERCIAL POWERED ANODE KIT

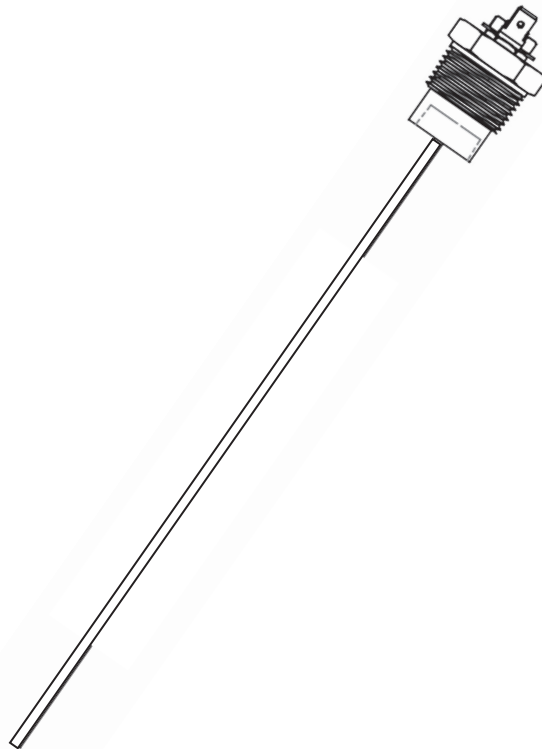

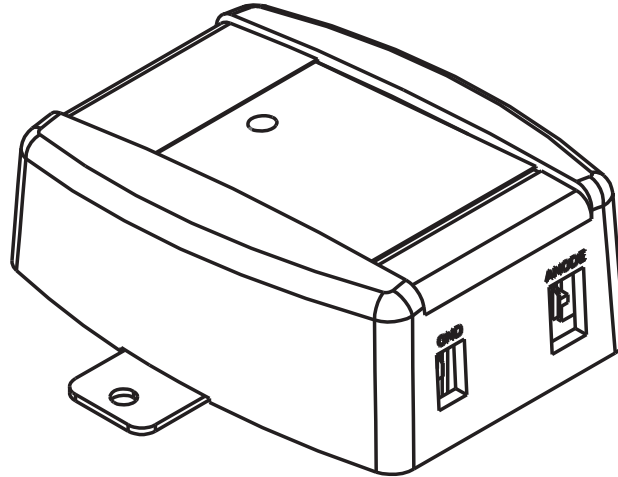



**KEEP THIS MANUAL IN THE POCKET ON HEATER FOR FUTURE REFERENCE WHENEVER MAINTENANCE
ADJUSTMENT OR SERVICE IS REQUIRED.**

CONTENTS

IMPORTANT SAFETY INFORMATION	3	Tools and Supplies Required:.....	6
SYSTEM CONTROL WIRING DIAGRAM.....	4	Procedure	7
INTRODUCTION	4	REGULATORY NOTICES	10
How Does the Powered Anode System Work?.....	4	FCC (United States of America).....	10
On Which Models Can I Use the Powered Anode System?...	5	ICES-003 (Canada).....	10
INSTALLATION.....	6	SPECIFICATIONS.....	10
Kit Components:	6	ASSISTANCE	10

IMPORTANT SAFETY INFORMATION

Your safety and the safety of others is extremely important in the installation, use and servicing of this appliance. Many safety-related messages and instructions have been provided in this manual and on your own water heater to warn you and others of a potential injury hazard. Read and obey all safety messages and instructions throughout this manual. It is very important that the meaning of each safety message is understood by you and others who install, use or service this water heater.

	This is the safety alert symbol. It is used to alert you to potential personal injury hazards. Obey all safety messages that follow this symbol to avoid possible injury or death. Keep this manual near the water heater.
	DANGER indicates an imminently hazardous situation which, if not avoided, will result in injury or death.
	WARNING indicates a potentially hazardous situation which, if not avoided, could result in injury or death.
	CAUTION indicates a potentially hazardous situation which, if not avoided, could result in minor or moderate injury.
	CAUTION used without the safety alert symbol indicates a potentially hazardous situation which, if not avoided, could result in property damage.

All safety messages will generally tell you about the type of hazard, what can happen if you do not follow the safety message, and how to avoid the risk of injury.

⚠ WARNING	
Safety Hazard	
	<p>Improper installation, operation, alteration, or service might cause a malfunction that results in property damage, personal injury, or death.</p> <p>Read and follow all instructions, cautions, and warnings in this manual as well as in the water heaters' use and care guide. Failure to do so can lead to property damage, personal injury or death.</p> <p>If you lack the necessary skills to install the Powered Anode System properly, or you have difficulty following the instructions, do not proceed with the installation. Have a qualified person perform the installation.</p> <p>The powered anode system must be installed according to all local and state codes or, in the absence of local and state codes, the current edition of the "National Electrical Code", ANSI/NFPA 70.</p>

SYSTEM CONTROL WIRING DIAGRAM

+12V EXTERNAL

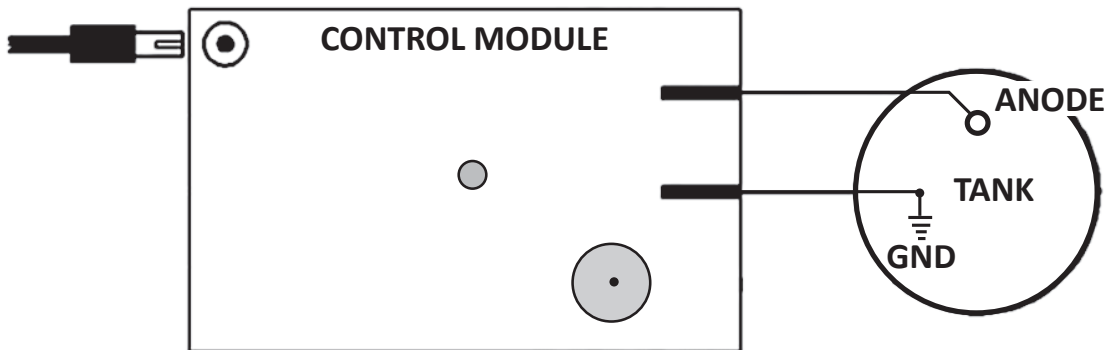

⚠ WARNING

Electrical Shock Hazard



Contact with electrical components can result in severe injury or death from electrical shock.

- **Ensure that power to the module is disconnected before installing or servicing the Powered Anode System.**
- Electric water heaters only: Disconnect power to the water heater by opening the circuit breaker(s) before installation or service
- Use a non-contact circuit tester to confirm that power is off before installation or service.
- Verify proper operation after servicing.

INTRODUCTION

HOW DOES THE POWERED ANODE SYSTEM WORK?

The Powered Anode System replaces sacrificial anodes which are normally shipped with water heaters.

In order to protect the water heater from corrosion, a traditional anode deteriorates over time. As a result, when an anode is consumed by the corrosive effects of water, the tank will begin to deteriorate. Leaks result. However, the Powered Anode System will not be consumed over time, and if it is not working properly, its alert system will notify you.

In short, the Powered Anode System measures the low levels of voltage that exist in the tank's water. It then supplies the necessary current (very slight) to help protect the tank's metal parts. It may also control water odor.

NOTICE: The powered anode system must remain plugged into a non-switched, powered outlet. Failure to do so could result in water heater damage, leaks, and property damage.

The Powered Anode System can be used with any DRE, DVE, or DSE water heater between 50 gallons and 120 gallons.

Note: One of the anodes will need to be removed.

If you are unsure of your anode's location, refer to the manual or call the manufacturer's technical assistance number.



Figure 1. Powered Anode Control Module

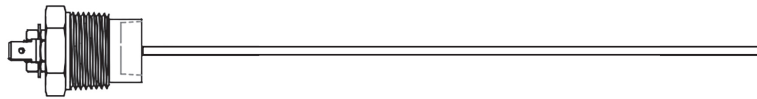



Figure 2. Powered Anode Electrode



Figure 3. Power Supply

INSTALLATION

FOLLOW ALL SAFETY NOTICES IN YOUR WATER HEATER'S MANUAL.

⚠ WARNING	
Electrical Shock Hazard	
	<p>Contact with electrical components can result in severe injury or death from electrical shock.</p> <ul style="list-style-type: none">• Ensure that power to the module is disconnected before installing or servicing the Powered Anode System.• Disconnect power to the water heater by opening the circuit breaker(s) before installation or service• Use a non-contact circuit tester to confirm that power is off before installation or service.• Verify proper operation after servicing.

KIT COMPONENTS:

- Control Module with two self-tapping screws
- Anode (Electrode)
- Power Supply (Input 120 VAC/
Output to module: 12 VDC)
- Wiring Harness

TOOLS AND SUPPLIES REQUIRED:

- 1-1/16" deep-well socket
- Air compressor (if an air impact wrench is used)
- Electric or air impact wrench
- Screwdriver or nut driver (to loosen/tighten screw on water heater jacket)
- Water Hose

PROCEDURE

1. Shut off the electric power supply to your water heater.
Refer to the shutdown instructions in your water heater's manual.
2. Drain the water heater according to these steps:
 - A. Turn off the cold water supply to the water heater.
 - B. Open hot water faucets to relieve the water pressure.
 - C. Attach a water hose to the drain valve. Run the hose to a drain or outdoors.
 - D. Open the drain valve and drain about five gallons of water from the water heater. (Water inside the heater will help hold the unit steady while removing the anode rod.)
 - E. Close the water heater drain valve, then close the hot water faucets.
3. Remove one of the old anode rods.
 - A. Locate the anode rod's hex head on top of the water heater.
 - B. Loosen the hex head with a quick burst from the impact wrench (1-1/16" socket).
 - C. Unscrew the anode by hand once it is loose. (This prevents tank damage.)
 - D. Remove the old anode rod. If you are in an area with a low ceiling, you can bend the anode rod, if needed.
4. Install the new anode from your kit:
 - A. Insert the new anode into the anode opening and start screwing it in by hand (clockwise).
Note: DO NOT use pipe dope or thread sealing tape on the anode's threads. It has sealant on the threads already.
Note: During the next step, use a deep well socket only. Doing so will prevent damage to the anode's flag terminal.
 - B. Tighten the anode with a deep well 1-1/16" socket until tight.

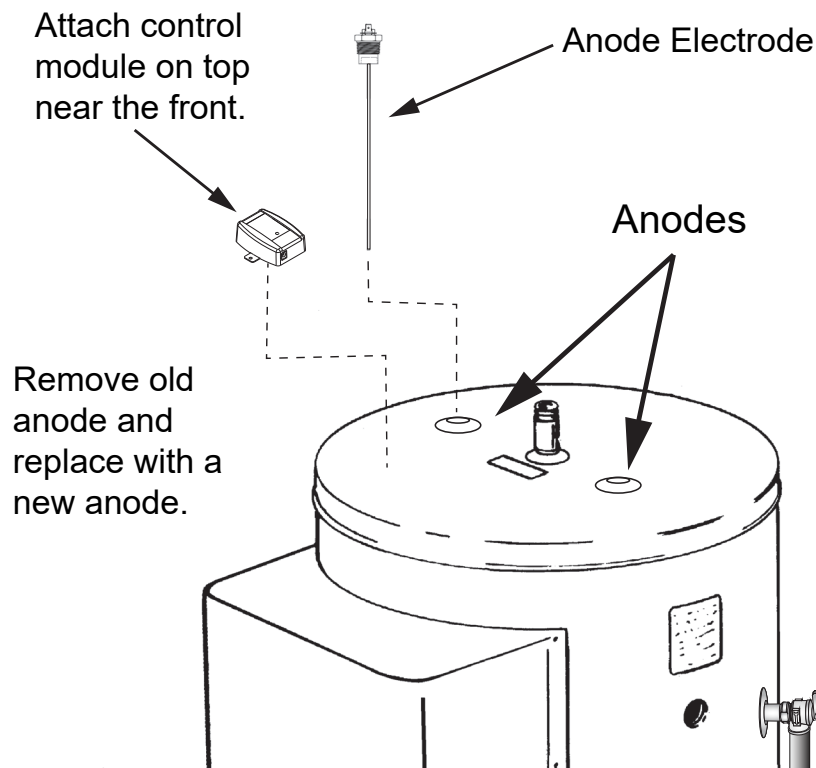

Figure 4. Top View of Heater

5. Attach the new control module:
 - A. Set the control module on top of the water heater. See Figure 5 or Figure 6.
 - B. Secure the module to the water heater's top with two self-tapping screws (provided).
6. Connect the wiring harness:

Note: During the following steps, plug each harness connector into the module carefully. To avoid damage, do not use excessive force or twist the connectors during installation.

 - A. Plug the harness' red wire connector into the module (Figure 5).
 - B. Plug the harness' green wire connector into the module (Figure 5).
 - C. Slide the wire harness' red wire spade connector onto the anode's flag terminal. See Figure 5 and Figure 6.
 - D. Secure the green wire's fork terminal underneath a jacket screw. See instructions in Figure 5 and Figure 8.
7. Return the water heater to service:
 - A. Ensure that the drain valve is closed, then open the cold water supply to the refill the water heater.
 - B. Open a hot water faucet and allow the water to run until it flows with a full stream.
 - C. Let the water run full stream for three minutes. Close the hot water faucet. **Check for leaks at the anode.**
 - D. Plug the power supply cord into the module.

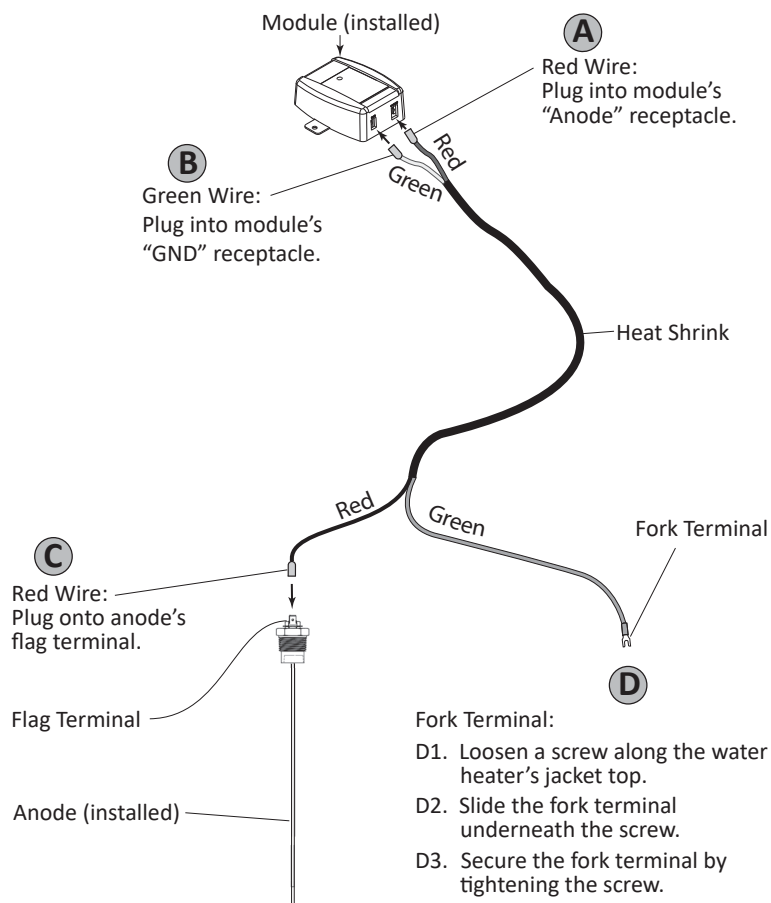

Figure 5. Harness Installation

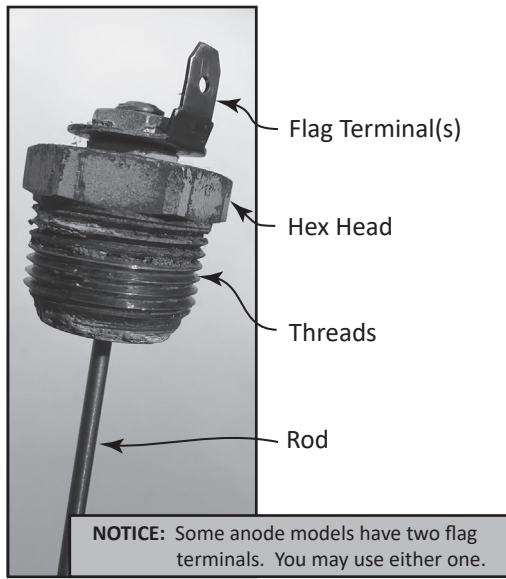

Figure 6. Top of new anode

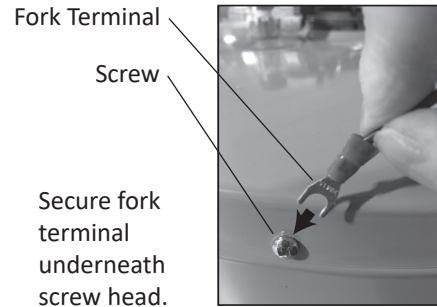

Figure 7. Fork Terminal Placement

- E. Plug the external power supply into a 120VAC wall outlet.
- F. Return the water heater to service according to its user manual. Verify proper operation.

Table 1. System Feedback	
LED	Description/ Corrective Action
Solid (Green)	System is operating properly (i.e., components are installed properly, module is powered, and the tank is full of water).
1 Flash (Red)*	Anode disconnected. Check for loose connections and breaks in the wire between the control module and the anode/tank. The tank connection must be to bare metal (i.e., not paint).
2 Flashes (Red)*	Anode shorted. 1.) Check for shorted wiring. Correct wiring as necessary. 2.) Check for corrosion on top of anode (electrode) and clean with a brush. 3.) Anode may have corrosion or contamination. Clean as described below. ⚠ WARNING! Electric Shock Risk. Contact with electrical components can result in severe injury or death from electrical shock. Use a non-contact circuit tester to confirm that power is off. Turn off power to the Powered Anode System. Disconnect power to the water heater if it is an electric model. Remove the anode and clean it with a cloth.
3 Flashes (Red)*	Module failure. Replace the control module.

* Beeper will sound during error code.

NOTICE:

- It will take about 20 seconds for the system to indicate an error condition.
- It may take several seconds for the system to show correct operation after corrections are made.

REGULATORY NOTICES

FCC (UNITED STATES OF AMERICA)

This equipment has been tested and found to comply with the limits for a Class B digital device, pursuant to part 15 of the FCC rules. These limits are designed to provide reasonable protection against interference in a commercial installation. This equipment generates, uses, and can radiate radio frequency energy and, if not installed and used in accordance with the instruction manual, may cause interference to radio communications. However, there is no guarantee that interference will not occur in a particular installation. If this equipment does cause interference to radio or television reception, which can be determined by turning the equipment off and on, the user is encouraged to try to correct the interference by one or more of the following measures:

- Reorient or relocate the receiving antenna.
- Increase the separation between the equipment and receiver.
- Connect the equipment into an outlet on a circuit different from that to which the receiver is connected.
- Consult the dealer or an experienced radio/TV technician

Caution: Changes or modifications to this equipment not expressly approved by the party responsible for compliance (A.O. Smith) could void the user's authority to operate the equipment.

ICES-003 (CANADA)

This Class B digital apparatus complies with Canadian ICES-003.

Cet appareil numérique de la classe B est conforme à la norme NMB-003 du Canada.

SPECIFICATIONS

Environmental Specifications:

- Humidity up to 95% non-condensing.
- Temperature, operational = -4°F to 158°F (-20°C to 70°C)
- Temperature, storage = -40°F to 176°F (-40°C to 80°C)
- Vibration = 0.5G

Power Supply (Provided):

Input 100-240VAC, 50-60Hz. 0.5A

Output 12V DC, 1.0A

Power Supply Requirements for Powered Anode System:

12V @ 150mA

ASSISTANCE

For warranty questions, call:

800.527.1953

When calling, be ready to provide the following information: your name, address, and telephone number; the serial number of your Powered Anode System; proof of purchase/installation; and a clear description of the problem.

