

## ProLine® Master Connected Electric Water Heaters

Our ProLine® Master Connected Electric water heaters are designed with iCOMM™ Wi-Fi technology greater control, leak detection and protection to provide homeowners with peace of mind.

### Features

#### Energy Savings

- Meets the NRCAN standby loss requirements

#### Designed for Performance

- Element dry-fire protection
- Leak detection sensor sounds alarm when water is detected
- Dual elements for fast recovery and reliable operation
- Self-cleaning diptube is made from long-lasting PEX cross-linked polymer and helps to reduce lime and sediment buildup and maximizes hot water output
- Anode rod with stainless steel core that extends the life of the rod, allowing superior tank protection far longer than standard anode rods
- Glass coating provides superior corrosion resistance compared to industry-standard glass lining
- CSA certified and ASME rated T&P relief valve

#### Serviceability

- Seven-segment electronic control display with diagnostic feedback and two operating modes
- Enhanced-flow solid brass, tamper-resistant ball type drain valve uses a standard female hose fitting that allows for fast and easy draining during maintenance. The drain valve includes an integral screwdriver slot that features a ¼ turn (open/close) radius, which permits full straight-through water flow and a quick and positive shut off
- Optional shut-off valve automatically shuts off incoming cold water when leak is detected

#### Exclusive Design

- Design-listed by Underwriters Laboratories, certified at 300 psi test pressure and 150 psi working pressure and listed according to UL 174 standards governing storage tank-type electric water heaters

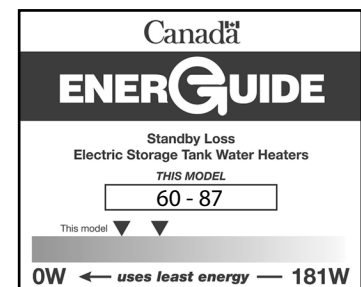

#### WARRANTY

8 year limited warranty on tank and parts  
on ProLine® Master models  
For complete information, consult written  
warranty or go to [johnwoodwaterheaters.com](http://johnwoodwaterheaters.com)

### SPECIFICATIONS

Model	Capacity			Input		Standby Loss WATTS	First Hour Rating USG (L)	Height to Top of Tank A IN (CM)	Diameter B IN (CM)	Approx. Shipping Weight LB (KG)	BC/ON/QC Compliant
	IG	USG	LITRES	240V	208V						
E50TEME-30	40	50	182	3,000W	2,253W	60	50 (188)	49 ¼ (125)	23 (59)	117 (53)	√
E50TEME-38	40	50	182	3,800W	3,000W	60	53 (202)	49 ¼ (125)	23 (59)	117 (53)	√
E80TEME-45	60	80	287	4,500W	3,500W	87	81 (305)	60 ½ (154)	24 (61)	174 (79)	√
E80TEME-55	60	80	287	5,500W	4,000W	87	85 (322)	60 ½ (154)	24 (61)	174 (79)	√

3/4" water connections on 8" center.

Only available for 240V.

Equipped as dual element only, no single element configurations available.

Dimensions and specifications subject to change without notice in accordance with our policy of continuous product improvement.

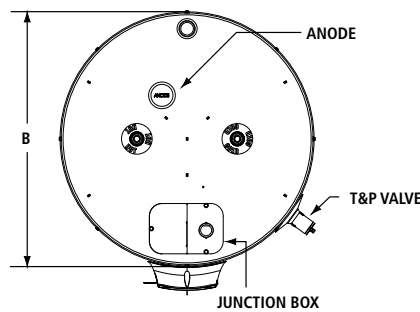
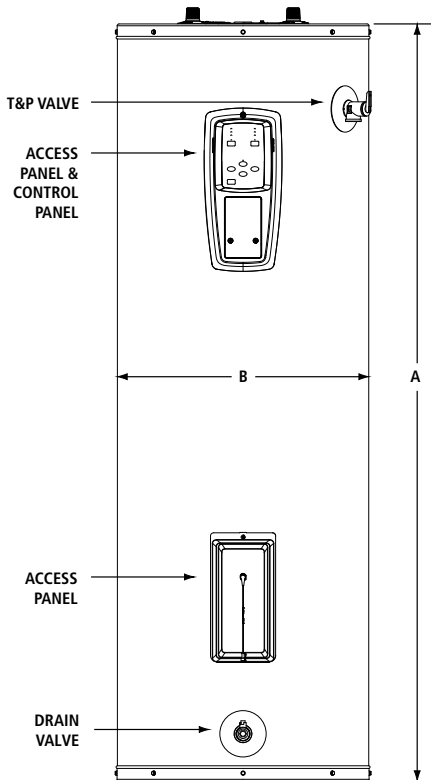

### CONTROL PANEL



### iCOMM™ SMART CONNECTIVITY

Download the free A. O. Smith app to get started.

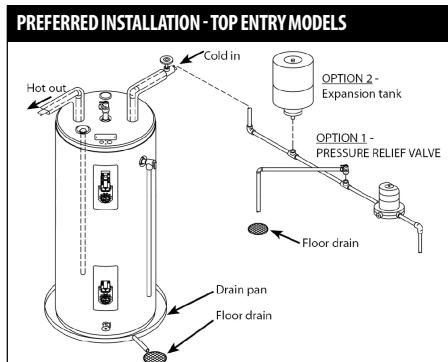

Apple logo and Apple App Store Logo are trademarks of Apple Inc.  
Google Play and the Google Play logo are trademarks of Google LLC.