



Giant®

Enhancing everyday living

RESIDENTIAL GAS-FIRED WATER HEATERS
POWER VENT

| 40 | 50 | 60 | U.S. GALLONS

FVIR COMPLIANT

All residential gas-fired water heaters are FVIR compliant, meeting the current edition of ANSI Z21.10.1 – CSA 4.1 standard for water heaters. Flammable vapour ignition resistance, or FVIR, means that the water heater is designed to prevent the accidental ignition of flammable vapours such as those from aerosol sprays, cleaning solvents, gasoline, paints, paint thinner, or lacquer.

Our power vent models have a unique FVIR design: an FV sensor shuts down the water heater when flammable vapours are detected and an air intake snorkel pulls clean combustion air from an area above where flammable vapours would collect near the water heater. This also allows the FV sensor to shut down the water heater before the vapours enter the combustion chamber.

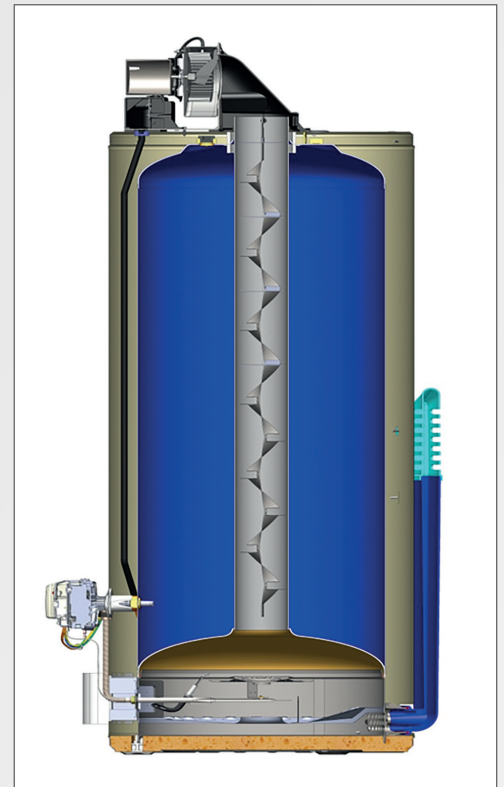

BENEFITS

ROTATABLE BLOWER

Equipped with a 3-position rotatable blower for optimized venting, energy efficiency and ease of installation.

TANKSAVER® DESIGN

An exclusive TankSaver® design to prolong tank life.

SIDE TAPS AVAILABLE

Convenient 3/4" side taps for combination applications on 50-62 high-input models.

GLASS-LINED INNER TANK

Glass lining provides superior protection against tank corrosion.

SENSOR DETECTION

Sensor detects the presence of flammable vapours and automatically disables the unit to prevent ignition.

AIR INTAKE SNORKEL

Robust air intake snorkel inhibits flammable vapours from entering the combustion chamber.

GAS CONTROL VALVE

State-of-the-art electronic gas control valve features advanced self diagnostic capability that makes troubleshooting easy.

FACTORY INSTALLED T&P RELIEF VALVE AND DRAIN VALVE

Conveniently located T&P and brass drain valve for ease of installation and serviceability.

HIGH-QUALITY MAGNESIUM ANODE

Top mounted heavy-duty magnesium anode rod for added tank protection.

VENTING OPTIONS

Can be vented horizontally or vertically with 2", 3" or 4" ULC S636 PVC, CPVC or polypropylene pipe, up to 180 equivalent feet.

MODELS AVAILABLE FOR PROPANE AND NATURAL GAS!



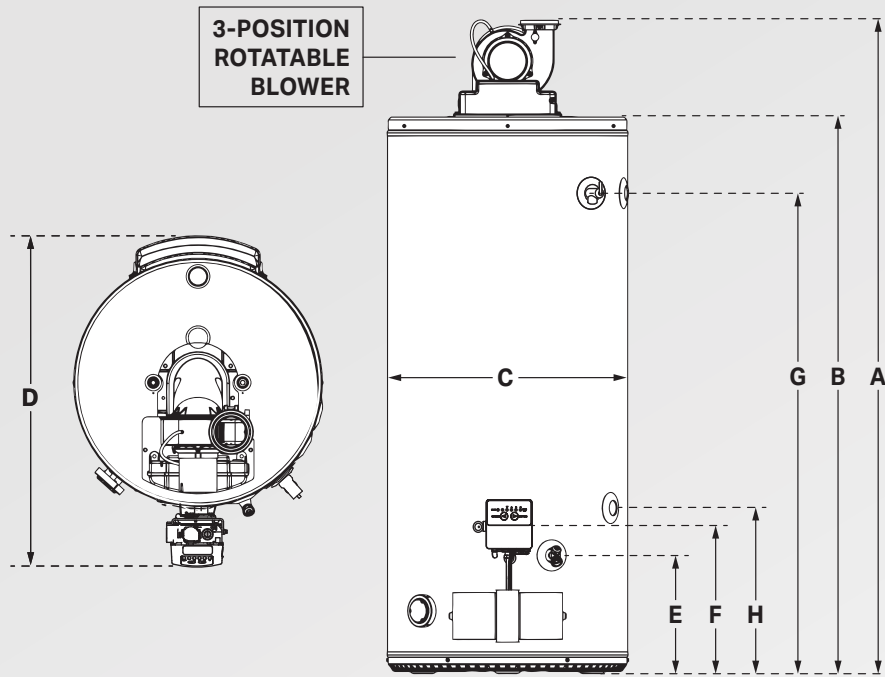

Canada
ENERGUIDE

Uniform Energy Factor (UEF)
Gas / Propane-fired Storage Water Heaters

This product's capacity*
Very small
Low
Medium
High

This product
0.67-0.73

more → energy use ← least

*Only compare products of similar capacities
Visit energiguide.gc.ca/water-heater-label for more information.



SPECIFICATIONS

Model	Capacity			Input BTU	Altitude Feet (Meters)	Recovery Rate 90°F / 50°C			First Hour Rating US gal.(L)	Energy Factor	UEF	Estimated Shipping Weight lb (kg)
	US gal.	Liters	IMP gal.			US gal.	Liters	gal. IMP				
NATURAL GAS												
UG40-40SPV3-N2 204	40	151	33	40,000	10,100 (3,078)	44	167	37	73 (276)	0.70	0.67	174 (79)
UG50-40SPV3-N2 204	50	189	42	40,000	10,100 (3,078)	44	167	37	90 (341)	0.70	0.72	198 (90)
UG50-62SPV3-N2 204*	50	189	42	62,000	10,100 (3,078)	69	261	57	110 (416)	0.73	0.73	212 (96)
UG60-42SPV3-N2 204	60	227	50	42,000	10,100 (3,078)	46	174	38	106 (401)	0.70	0.69	216 (98)
PROPANE GAS												
UG40-40SPV3-P2 201	40	151	33	40,000	10,100 (3,078)	44	167	37	73 (276)	0.70	0.67	174 (79)
UG50-40SPV3-P2 201	50	189	42	40,000	10,100 (3,078)	44	167	37	90 (341)	0.70	0.72	198 (90)
UG50-62SPV3-P2 201*	50	189	42	62,000	10,100 (3,078)	69	261	57	110 (416)	0.73	0.73	212 (96)
UG60-42SPV3-P2 201	60	227	50	42,000	10,100 (3,078)	46	174	38	106 (401)	0.70	0.69	216 (98)

DIMENSIONS

Model	A		B		C		D		E		F		G		H	
	inches	(cm)	inches	(cm)	inches	(cm)	inches	(cm)	inches	(cm)	inches	(cm)	inches	(cm)	inches	(cm)
UG40	59	(150)	49 5/8	(126)	22	(56)	29 1/8	(74)	11	(28)	13 1/4	(34)	42 1/2	(108)	—	—
UG50-40	60 1/8	(153)	50 3/4	(129)	24	(61)	31 1/8	(79)	11	(28)	13 1/4	(34)	43 3/4	(111)	—	—
UG50-62	61 1/8	(155)	52	(132)	24	(61)	31 1/8	(79)	11	(28)	13 1/4	(34)	44 1/2	(113)	15 1/4	(39)
UG60	67 1/4	(171)	57 7/8	(147)	24	(61)	31 1/8	(79)	11	(28)	13 1/4	(34)	50 3/8	(128)	—	—

*Models with side 3/4" side taps.
 All models are suitable for potable water and space heating applications.
 Toxic chemicals, such as those used for boiler treatment, must NEVER be introduced into this system.
 These unit must NEVER be connected to any existing heating system or component(s) previously used with a non-potable water heating appliance.
 All models are certified for normal and high altitude applications.
 For specific details, consult the owner's manual provided with each water heater.

WARRANTY

<p style="font-size: 1.2em; font-weight: bold; color: red; margin: 0;">6 years</p> <p style="font-size: 0.8em; margin: 0;">against inner tank leakage</p>	<p style="font-size: 1.2em; font-weight: bold; color: red; margin: 0;">6 years</p> <p style="font-size: 0.8em; margin: 0;">on component parts</p>
---	---

Giant offers a SIX (6)* year limited warranty against inner tank leakage on residential atmospheric vent water heaters from the date of installation and a SIX (6)* year limited warranty on component parts. For specific warranty details including exceptions, consult the owner's manual provided with each water heater.

*When installed by a professional.

Giant®

11021, Notre-Dame Street East, Montreal-East, Quebec, Canada, H1B 5H3
 Telephone : 514-645-8893 • Toll free : 1-800-363-9354
 General fax : 514-640-0969
 Customer Service fax : 514-645-8413

giantinc.com