

DURA-POWER™ XI COMMERCIAL ELECTRIC

ADVANCED ELECTRONIC CONTROL

- A. O. Smith's new propriety electronic water heater control, provides precise + or - 1°F temperature control, that is ideal for industrial and food service applications where accurate hot water temperatures are needed.

EASY-TO-READ TEXT

- Animated icons display detailed operational and diagnostic information. Fault or alert messages appear if an operational issue occurs.

LOW WATER CUT-OFF

- Factory standard on board low water cut-off uses a remote electronic immersion type probe to prevent energizing of the elements in the event of low water condition and eliminates accidental dry firing.

PROGRESSIVE MODULATING

- Matches number of elements to current load conditions. Rotates and lead lags element loads to provide long life and equal wear.

ECONOMY MODE OPERATION

- Control system automatically lowers the operating set point by a programmed value during user defined time periods. Seven-day clock may be programmed for night set back and or weekend shutdown to reduce operating cost and save money.

BMS COMPATIBLE

- Modbus/BACnet compatible with optional Gateway interface. Call 888 WATER02 for more information.

PERMAGLAS® GLASS LINING IS STANDARD

- Exclusive process provides superior protection against corrosion in varying water conditions. Cement linings are optional.

ASME CODE CONSTRUCTION

- All models are constructed to the requirements of ASME and are available in 125, 150 and 160 psi working pressures (125 psi working pressure - standard). Consult factory for ASME code tanks with greater or lesser working pressures and special configurations or materials.

INCOLOY IMMERSION HEATERS

- Heavy-duty elements have incoloy sheathing: provide excellent protection against oxidation and scaling. The input ranges from 15kW to 900kW (see accompanying chart).

FUSING

- Control and power circuit fusing to meet N.E.C.

COMPLIANCE

- Meets the standby loss requirements of NRCan and current edition of ASHRAE/IES 90.1.

MAGNETIC CONTACTOR(S)

- Heavy duty UL rated for 100,000 cycles.

OTHER STANDARD FEATURES

- Colour-coded circuitry for easier servicing
- Anode rods for maximum corrosion protection
- Standard voltages include 208, 240, 380, 400, 415, 480, 600 volt single or three-phase
- International voltages available (consult factory)
- Factory-installed terminal block(s)
- Temperature and pressure relief valve

OPTIONAL DUAL-ENERGY SOURCE CAPABILITY

- Provides emergency back up energy source or winter/summer boiler operation. Can be specified with optional water to water or steam to water heat exchangers. Both single and double-wall heat exchangers are available. Complete control packages can be factory-installed for hook-up and run capability.

THREE YEAR LIMITED WARRANTY

- For complete warranty information consult written warranty or go to hotwater.com



DVE-150 THRU 2500



DHE-150 THRU 2500



Vertical Round Models 150-1000

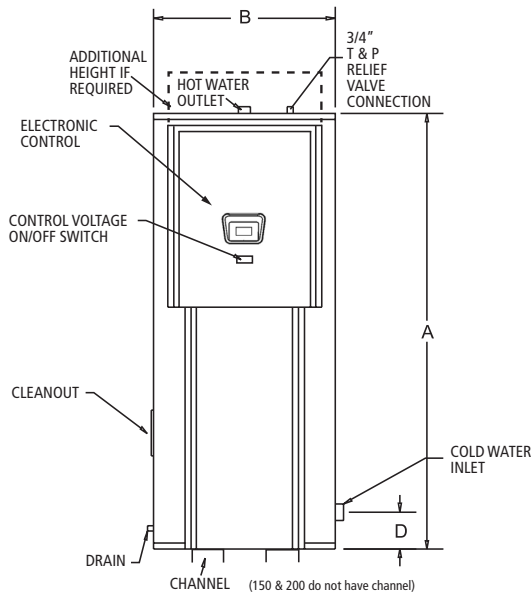

TOP VIEW

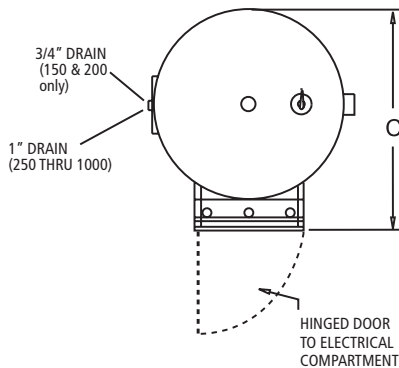

Vertical Square Models 1250-2500

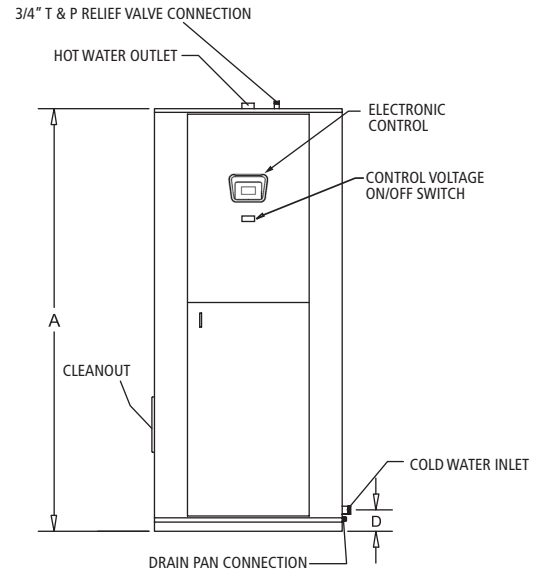

TOP VIEW

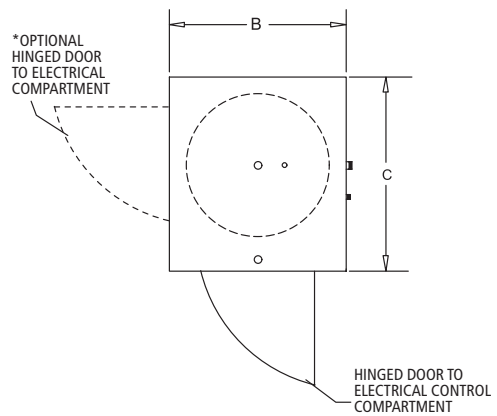

*An oversized control panel may be required on models with inputs above 72 kW. An oversized control panel may increase the width and depth of the square jacket by up to 2".

Horizontal Models

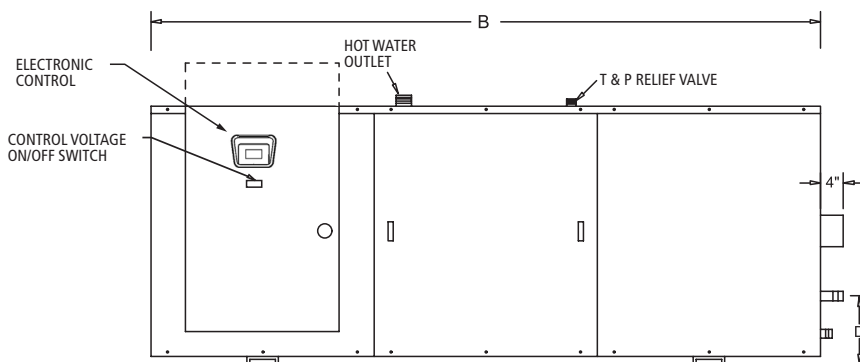

A & D ELEVATION FROM FINISHED FLOOR

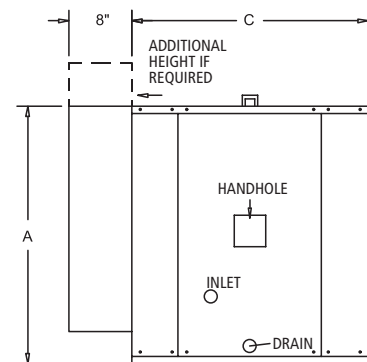

END VIEW

EXTRA PANEL BOX MAY BE NECESSARY FOR INPUTS HIGHER THAN 72KW. CONSULT FACTORY



Commercial Electric Water Heaters

| MODEL NUMBER | MAX. KW | TANK CAPACITY | | DIMENSIONS | | | | | | | | WATER CONNECTION | | SHIPPING WEIGHT | |
|--|---------|---------------|-------|------------|-----|---------|-----|--------|-----|--------|----|------------------|-----------------|-----------------|-------|
| | | | | A | | B | | C | | D | | INLET OPENINGS | OUTLET OPENINGS | | |
| | | USG | LITRE | INCHES | CM | INCHES | CM | INCHES | CM | INCHES | CM | IN (NPT) | IN (NPT) | LB | KG |
| VERTICAL ROUND ELECTRIC STORAGE HEATER | | | | | | | | | | | | | | | |
| DVE-150A | 156 | 150 | 568 | 65-1/2 | 166 | 32 | 81 | 38-3/4 | 98 | 11-3/4 | 30 | 1-1/2 | 1-1/2 | 650 | 295 |
| DVE-200A | 195 | 200 | 757 | 78 | 198 | 32 | 81 | 38-3/4 | 98 | 11-3/4 | 30 | 1-1/2 | 1-1/2 | 750 | 340 |
| DVE-250A | 228 | 250 | 946 | 92 | 234 | 34 | 86 | 40-3/4 | 104 | 19-1/4 | 49 | 1-1/2 | 1-1/2 | 1,165 | 528 |
| DVE-300A | 276 | 300 | 1,136 | 80 | 203 | 40 | 102 | 46-3/4 | 119 | 20-3/4 | 53 | 2 | 2 | 1,350 | 612 |
| DVE-400A | 324 | 400 | 1,514 | 80 | 203 | 46 | 117 | 52-3/4 | 134 | 22-1/4 | 57 | 2 | 2 | 1,590 | 721 |
| DVE-500A | 420 | 500 | 1,893 | 92 | 234 | 46 | 117 | 52-3/4 | 134 | 22-1/4 | 57 | 2 | 2 | 1,700 | 771 |
| DVE-600A | 420 | 600 | 2,271 | 92 | 234 | 52 | 132 | 60-3/4 | 154 | 24-1/4 | 62 | 2-1/2 | 2-1/2 | 2,010 | 912 |
| DVE-800A | 432 | 750 | 2,839 | 104 | 264 | 52 | 132 | 60-3/4 | 154 | 24-1/4 | 62 | 2-1/2 | 2-1/2 | 2,450 | 1,111 |
| DVE-1000A | 432 | 950 | 3,596 | 128 | 325 | 52 | 132 | 60-3/4 | 154 | 24-1/4 | 62 | 2-1/2 | 2-1/2 | 3,160 | 1,433 |
| VERTICAL SQUARE ELECTRIC STORAGE HEATER | | | | | | | | | | | | | | | |
| DVE-1250A | 900 | 1,250 | 4,732 | 132-1/2 | 337 | 64-1/2 | 164 | 64-1/2 | 164 | 23-1/4 | 59 | 3 | 3 | 3,560 | 1,615 |
| DVE-1500A | 900 | 1,500 | 5,678 | 128-1/2 | 326 | 70-1/2 | 179 | 70-1/2 | 179 | 25-1/4 | 64 | 3 | 3 | 4,120 | 1,869 |
| DVE-2000A | 900 | 2,000 | 7,571 | 124-1/2 | 316 | 78-1/2 | 199 | 78-1/2 | 199 | 27 | 69 | 3 | 3 | 4,350 | 1,973 |
| DVE-2500A | 900 | 2,500 | 9,464 | 146-1/2 | 372 | 82-1/2 | 210 | 82-1/2 | 210 | 29 | 74 | 3 | 3 | 5,750 | 2,608 |
| HORIZONTAL SQUARE ELECTRIC STORAGE HEATER | | | | | | | | | | | | | | | |
| DHE-150A | 162 | 150 | 568 | 37 | 94 | 68-1/2 | 174 | 34-1/4 | 87 | 12 | 31 | 2 | 2 | 1,180 | 535 |
| DHE-200A | 195 | 200 | 757 | 37 | 94 | 78 | 198 | 34-1/4 | 87 | 12 | 31 | 2 | 2 | 1,370 | 621 |
| DHE-250A | 228 | 250 | 946 | 39 | 99 | 90-1/4 | 229 | 36-1/4 | 92 | 13 | 33 | 2 | 2 | 1,450 | 658 |
| DHE-300A | 276 | 300 | 1,136 | 45 | 114 | 78-1/4 | 199 | 42-1/4 | 107 | 14-3/4 | 37 | 2 | 2 | 1,530 | 694 |
| DHE-400A | 324 | 400 | 1,514 | 52 | 132 | 78-1/4 | 199 | 48-1/4 | 123 | 16 | 41 | 2 | 2 | 1,750 | 794 |
| DHE-500A | 420 | 500 | 1,893 | 52 | 132 | 90-3/4 | 231 | 48-1/4 | 123 | 16 | 41 | 2 | 2 | 1,860 | 844 |
| DHE-600A | 420 | 600 | 2,271 | 58 | 147 | 90-3/4 | 231 | 54-1/4 | 138 | 13-1/2 | 34 | 2-1/2 | 2 | 2,340 | 1,061 |
| DHE-800A | 432 | 750 | 2,839 | 58 | 147 | 102-1/4 | 260 | 54-1/4 | 138 | 13-1/2 | 34 | 2-1/2 | 2 | 2,850 | 1,293 |
| DHE-1000A | 432 | 950 | 3,596 | 58 | 147 | 126-1/4 | 321 | 54-1/4 | 138 | 13-1/2 | 34 | 2-1/2 | 2 | 3,040 | 1,379 |
| DHE-1250A | 900 | 1,250 | 4,732 | 64 | 163 | 130-1/4 | 331 | 60-1/4 | 153 | 15 | 38 | 3 | 3 | 3,750 | 1,701 |
| DHE-1500A | 900 | 1,500 | 5,678 | 70 | 178 | 126-1/4 | 321 | 66-1/4 | 168 | 16 | 41 | 3 | 3 | 4,340 | 1,969 |
| DHE-2000A | 900 | 2,000 | 7,571 | 82 | 208 | 123-1/4 | 313 | 78-1/4 | 199 | 14 | 36 | 3 | 3 | 4,580 | 2,077 |
| DHE-2500A | 900 | 2,500 | 9,464 | 82 | 208 | 144-1/4 | 366 | 78-1/4 | 199 | 16-1/2 | 42 | 3 | 3 | 6,060 | 2,749 |

For higher inputs consult the factory.



Commercial Electric Water Heaters

| KW INPUT | GPH 100°F RISE | BTU/h EQUIVALENT | MAX. NO. OF ELEMENTS | NO. OF CONTROL STEPS | KW PER ELEMENT | NO. OF CONTACTORS 240/480V | SUGGESTED MODULATING CONTROL STEPS 240/480V | AMPERAGE DRAW | | | | | |
|----------|----------------------|---------------------|----------------------------|----------------------------|-------------------|----------------------------------|---|--------------------|--------------------|-------------|------|------|------|
| | | | | | | | | SINGLE PHASE | | THREE PHASE | | | |
| | | | | | | | | 208V | 240V | 208V | 240V | 480V | 600V |
| 15 | 62 | 51,180 | 1 | 1 | 15 | 2/1 | | 72 | 63 | 42 | 36 | 18 | 15 |
| 18 | 74 | 61,416 | 1 | 1 | 18 | 2/1 | | 87 | 75 | 50 | 44 | 22 | 18 |
| 30 | 123 | 102,360 | 2 | 1 | 15 | 2/1 | | 144 | 125 | 83 | 72 | 36 | 29 |
| 36 | 148 | 122,832 | 2 | 1 | 18 | 4/2 | 4/2 | 174 | 150 | 100 | 87 | 44 | 35 |
| 45 | 185 | 153,540 | 3 | 1 | 15 | 3/2 | 3/2 | 216 | 188 | 125 | 108 | 54 | 44 |
| 54 | 221 | 184,248 | 3 | 1 | 18 | 6/2 | 3/2 | 260 | 225 | 150 | 130 | 65 | 52 |
| 60 | 246 | 204,720 | 4 | 2 | 15 | 12/6 | 4/3 | 289 | 250 | 167 | 144 | 72 | 58 |
| 72 | 295 | 245,664 | 4 | 2 | 18 | 8/4 | 4/4 | Not Recommended | Not Recommended | 200 | 174 | 87 | 70 |
| 90 | 369 | 307,080 | 5 | 2 | 18 | 6/3 | 3/3 | | | 250 | 217 | 109 | 87 |
| 108 | 443 | 368,496 | 6 | 2 | 18 | 12/4 | 4/4 | | | 300 | 260 | 130 | 104 |
| 120 | 492 | 409,440 | 8 | 3 | 15 | 8/4 | 4/4 | | | 333 | 289 | 144 | 116 |
| 135 | 554 | 460,620 | 9 | 3 | 15 | 9/6 | 4/4 | | | 375 | 325 | 162 | 130 |
| 144 | 590 | 491,328 | 8 | 3 | 18 | 16/8 | 4/4 | | | 400 | 347 | 174 | 139 |
| 162 | 664 | 552,744 | 9 | 3 | 18 | 18/6 | 8/6 | | | 450 | 389 | 195 | 156 |
| 180 | 738 | 614,160 | 10 | 4 | 18 | 20/10 | 8/8 | | | 500 | 434 | 217 | 174 |
| 216 | 886 | 736,992 | 12 | 4 | 18 | 24/8 | 8/8 | | | 600 | 519 | 260 | 208 |
| 234 | 959 | 798,408 | 13 | 5 | 18 | 26/13 | 8/8 | | | 650 | 563 | 282 | 226 |
| 252 | 1,033 | 859,824 | 14 | 5 | 18 | 28/14 | 8/8 | | | 700 | 607 | 304 | 243 |
| 270 | 1,107 | 921,240 | 15 | 5 | 18 | 30/10 | 12/10 | | | 750 | 649 | 325 | 260 |
| 288 | 1,181 | 982,656 | 16 | 6 | 18 | 32/16 | 12/12 | | | 800 | 692 | 347 | 278 |
| 306 | 1,255 | 1,044,072 | 17 | 6 | 18 | 34/17 | 12/12 | | | 850 | 736 | 368 | 295 |
| 324 | 1,328 | 1,105,488 | 18 | 6 | 18 | 36/12 | 12/12 | | | 900 | 780 | 390 | 312 |
| 342 | 1,402 | 1,166,904 | 19 | 7 | 18 | 38/19 | 12/12 | | | 950 | 822 | 412 | 330 |
| 360 | 1,476 | 1,228,320 | 20 | 7 | 18 | 40/20 | 12/12 | | | 1,000 | 865 | 435 | 347 |
| 378 | 1,550 | 1,289,736 | 21 | 7 | 18 | 42/14 | 14/14 | | | 1,050 | 909 | 455 | 364 |
| 396 | 1,624 | 1,351,152 | 22 | 8 | 18 | 44/22 | 15/16 | | | 1,100 | 952 | 477 | 381 |
| 414 | 1,697 | 1,412,568 | 23 | 8 | 18 | 46/23 | 16/16 | | | 1,150 | 995 | 498 | 399 |
| 432 | 1,771 | 1,473,984 | 24 | 8 | 18 | 48/16 | 16/16 | 1,200 | 1,040 | 520 | 416 | | |

For higher inputs consult the factory.



Commercial Electric Water Heaters

TANK LININGS OPTIONS

CEMENT

- A special formulation of cement providing excellent corrosion protection. Available on 250 gallon and larger tanks.

SPECIAL CONSTRUCTION OPTIONS

"12 X 16" MANHOLE – AVAILABLE ON 250 GALLON AND ABOVE

150 OR 160 PSI WORKING PRESSURE

- Must be specified at time of order.

OTHER OPTIONAL FEATURES

TEMPERATURE AND PRESSURE RELIEF VALVES

- For working pressures other than standard; consult factory.

HORIZONTAL OR VERTICAL

- See specifications, most gallon capacities may be obtained in vertical or horizontal construction.

CIRCULATING PUMP PACKAGE

- Circulating pump and piping sized to turn over entire storage capacity of tank once each hour. Recommended to optimize available water at temperature in horizontal tanks particularly where low draw conditions are anticipated.

OPTIONAL INTERNATIONAL VOLTAGES

- 380 and 415 volts three-phase.

FACTORY-INSTALLED DIAL-TYPE PRESSURE GAUGE

FACTORY-INSTALLED DIAL-TYPE TEMPERATURE GAUGE

CONTROL OPTIONS

HOT WATER GENERATING TUBE HEAT EXCHANGERS

- Custom dual energy source units with heating units and control trim and can be built to design specifications on a special order basis for steam or boiler water applications. Consult factory or Hot Water Generator specification sheets for tube bundle sizing information and control options.

- Allows for remote connection to building demand limiter or other functions.

PILOT LIGHTS AND SWITCHES

- Denotes heating stage(s) in operation. Up to one light per contactor is available.
- A simple means of load control allows all or part of unit input to be controlled manually. Up to one switch per contactor is available.

SAFETY DOOR INTERLOCK

- Prevents opening of control panel door when heater power supply is on. NOTE: Once door is opened heater may be energized if necessary for service diagnosis.

SHUNT TRIP CIRCUIT BREAKER

- A safety device (circuit breaker) which disconnects power to heater in the event of over-current, high temperature or low water level, breaker must be manually reset and field installed.

SAMPLE SPECIFICATIONS

The heater(s) shall be A. O. Smith Commercial Electric Model Number _____ or an approved equal. Heater(s) shall be rated at _____ kW, _____ V, _____ phase, 60 cycle AC. The heater shall be for (vertical/horizontal) installation with lifting lug access and channel skid base not on every tank. Vessel shall be constructed to Section IV of the ASME Code for 125 psi working pressure. Vessel shall be glass-lined with anodic protection. Entire vessel and electrical controls are to be encased in a sheet metal enclosure with baked enamel finish. Tank to be insulated with fiberglass insulation. Enclosure to have hinged locking door over electric controls. There shall be _____ individually replaceable heavy duty Incoloy sheathed heating elements each complete with prewired terminal leads. These elements will be switched by magnetic contactors which are operated by a 120V fused control circuit protected by manual reset high limit. Control circuit is activated by a master pilot switch and electronic low water cutoff. This control shall prevent the entire electrical load from being switched on instantaneously. The control shall have even load progressive sequencing which utilizes the "first on, first off" principle thereby equalizing the operating time of heating elements and contactors. Each magnetic contactor and heating element circuit will be protected by a maximum of 60 amp cartridge type fuses with a minimum of 100,000 amp interrupting capacity. The entire water heating package shall be prewired to solderless terminal lugs, factory tested, complete with a CSA Certified and ASME Rated T&P relief valve and bear the Underwriters' Laboratories label. Heater(s) shall have a 3-year limited warranty as outlined in the written warranty. Fully illustrated instruction manual included. Water heater unit(s) shall be compatible with building management systems using Modbus or BACnet with factory supplied gateway.



Commercial Electric Water Heaters

For Technical Information call 888-599-2837. A. O. Smith Enterprises Ltd. reserves the right to make product changes or improvements without prior notice.

February 2025

www.hotwatercanada.ca | 888-599-2837 Toll-free Canada | A. O. Smith Enterprises Ltd. | 599 Hill Street West | Fergus, ON N1M 2X1

©2025 A. O. Smith Enterprises Ltd. All rights reserved.

Page 6 of 6
CANCE15500