



Residential Product Guide



John Wood® Safety Systems

Flammable Vapour Ignition Resistant (FVIR) technology you can trust.

John Wood residential water heaters use one of three unique Flammable Vapour Ignition Resistant (FVIR) Safety Systems that reduce the risk of accidental fires caused by the ignition of flammable vapours from products such as gasoline, paint thinner and solvents: the Flame Guard® and Flame Safe™ Safety Systems and the Power Vent Safety System.



Flame Guard® Safety System Used on John Wood Atmospheric Vent Water Heaters

The Flame Guard® Safety System is a recognized and proven technology used on John Wood Atmospheric Vent water heaters. The award winning Flame Guard® Safety System protects the consumer by trapping burning vapours within the water heater combustion chamber through the patented “Flame-Trap.” As long as the vapours are present and within the flammability range, they will continue to burn safely until they “burn themselves out.”



Flame Safe™ Safety System Used on John Wood Direct Vent Water Heaters

Flame Safe™ technology - designed to protect the consumer against the ignition of flammable vapours.

Power Vent Safety System

The Safety System used on John Wood Power Vent water heaters features a flammable vapour sensor and air intake snorkel. This system not only shuts down the unit when flammable vapours are detected in the area of the water heater but elevates the air intake so that flammable vapours do not enter the combustion chamber and ignite before the sensor shuts down the water heater.

Table of Contents

RESIDENTIAL TANK-TYPE PRODUCTS

Electric Water Heaters	4
ProLine® & ProLine® Master	4
ProLine® Master Connected	6
Space Saver®	8
Voltex® AL Connected Heat Pump	10
Gas Water Heaters	13
ProLine® & ProLine® Master Atmospheric Vent	13
ProLine® XE Atmospheric Vent	15
ProLine® XE Power Vent	17
ProLine® XE Power Direct Vent	19
ProLine® Direct Vent	21
High-efficiency Gas Water Heaters	23
Envirosense® Power Vent	23
Envirosense® Power Direct Vent	25
Envirosense® SF	27
Polaris™	29

RESIDENTIAL TANKLESS PRODUCTS

Powered by Takagi	31
Electric Tankless Products	32
Point-of-Use Tankless	32
Gas Tankless Products	37
Adapt™ Tankless	37
Condensing Tankless	41

RESIDENTIAL STORAGE TANK PRODUCTS

Storage Booster Tank	45
Flow THRU® Series Storage Tanks	47

APPENDICES

Ohm's Law	48
Reference Guide for Water Heating	48

ProLine® & ProLine® Master Electric

Features

Energy Savings

- Meets and exceeds NRCan energy efficiency standards
- Styropour™ base for added energy efficiency

Designed for Performance

- ProLine® and ProLine® Master models are residential water heaters with commercial-grade quality
- Factory-installed plastic-lined heat trap nipples
- Exclusive TankSaver® design to prolong tank life
- Glass lining provides superior protection against tank corrosion
- Thermostatically controlled, long life elements
- Brass drain valve
- CFC-free foam insulation

Serviceability

- Conveniently located T&P and drain valve for ease of installation and serviceability
- Top-mounted heavy duty anode rod for added tank protection

Exclusive Design

- The exclusive TankSaver® design aids the glass lining process to ensure optimum coverage, and guards tank openings for watertight connections

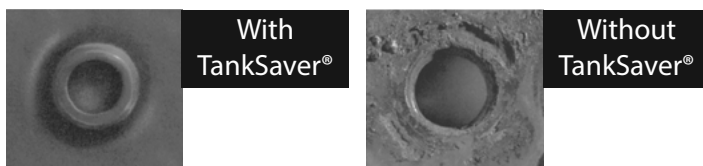
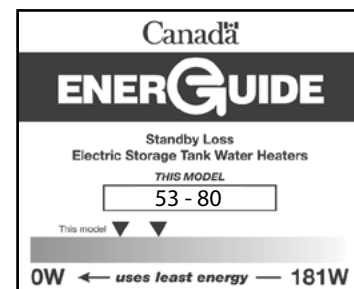

WARRANTY

6 year limited tank and parts on ProLine® models
 8 year limited tank and parts on ProLine® Master models
 2 or 4 year tank warranty extension kits are available for 6 year models

SPECIFICATIONS

Model	Series	Capacity			Elements (Upper and Lower)		Standby Loss WATTS	Energy Factor	First Hour Rating USG (L)	Height to Top of Tank A IN (CM)	Diameter B IN (CM)	Shipping Weight LB (KG)	Warranty Tank/Parts Years	BC/ON/QC Compliant
		IG	USG	LITRES	WATTS	VOLTS								
TOP ENTRY														
E50TE-30208	250	40	50	182	3000	208	53	0.92	50 (188)	48 ¾ (124)	22 (56)	125 (57)	6/6	✓
E50TE-30240	250	40	50	182	3000 ⁺	240	53	0.92	50 (188)	48 ¾ (124)	22 (56)	125 (57)	6/6	✓
E50TE-38240	250	40	50	182	3800 ⁺⁺	240	53	0.92	53 (202)	48 ¾ (124)	22 (56)	125 (57)	6/6	✓
E50TE-45208	250	40	50	182	4500	208	53	0.92	57 (214)	48 ¾ (124)	22 (56)	125 (57)	6/6	✓
E50TE-45240	250	40	50	182	4500 ⁺⁺⁺	240	53	0.92	57 (214)	48 ¾ (124)	22 (56)	125 (57)	6/6	✓
E50TE-55208	250	40	50	182	5500	208	53	0.92	61 (231)	48 ¾ (124)	22 (56)	125 (57)	6/6	✓
E50TE-60240	250	40	50	182	6000 ⁺⁺⁺⁺	240	53	0.92	63 (240)	48 ¾ (124)	22 (56)	125 (57)	6/6	✓
E66TE-38240	275	50	66	250	3800 ⁺⁺	240	79	0.88	69 (261)	60 ¼ (153)	22 (56)	146 (66)	6/6	
E66TE-45208	275	50	66	250	4500	208	79	0.88	72 (273)	60 ¼ (153)	22 (56)	146 (66)	6/6	
E66TE-45240	275	50	66	250	4500 ⁺⁺⁺	240	79	0.88	72 (273)	60 ¼ (153)	22 (56)	146 (66)	6/6	
E80TE-30208	250	60	80	287	3000	208	78	0.90	74 (279)	60 ½ (154)	24 (61)	170 (77)	6/6	✓
E80TE-30240	250	60	80	287	3000 ⁺	240	78	0.90	74 (279)	60 ½ (154)	24 (61)	170 (77)	6/6	✓
E80TE-38240	250	60	80	287	3800 ⁺⁺	240	78	0.90	77 (293)	60 ½ (154)	24 (61)	170 (77)	6/6	✓
E80TE-45208	250	60	80	287	4500	208	78	0.90	81 (305)	60 ½ (154)	24 (61)	170 (77)	6/6	✓
E80TE-45240	250	60	80	287	4500 ⁺⁺⁺	240	78	0.90	81 (305)	60 ½ (154)	24 (61)	170 (77)	6/6	✓
E80TE-55208	250	60	80	287	5500	208	78	0.90	85 (322)	60 ½ (154)	24 (61)	170 (77)	6/6	✓
E80TE-60240	250	60	80	287	6000 ⁺⁺⁺⁺	240	78	0.90	87 (331)	60 ½ (154)	24 (61)	170 (77)	6/6	✓
TOP ENTRY														
E50TEM-30240	250	40	50	182	3000 ⁺	240	53	0.92	50 (188)	48 (122)	22 (56)	122 (55)	8/8	✓
E50TEM-38240	250	40	50	182	3800 ⁺⁺	240	53	0.92	53 (202)	48 (122)	22 (56)	122 (55)	8/8	✓
E80TEM-45240	250	60	80	287	4500 ⁺⁺⁺	240	78	0.90	81 (305)	60½ (154)	24 (61)	170 (77)	8/8	✓
BOTTOM ENTRY														
E50BE-30208	250	40	50	182	3000	208	65	0.91	50 (188)	48 (122)	22 (56)	122 (55)	6/6	✓
E50BE-30240	250	40	50	182	3000 ⁺	240	65	0.91	50 (188)	48 (122)	22 (56)	122 (55)	6/6	✓
E50BE-45208	250	40	50	182	4500	208	65	0.91	57 (214)	48 (122)	22 (56)	122 (55)	6/6	✓
E50BE-45240	250	40	50	182	4500 ⁺⁺⁺	240	65	0.91	57 (214)	48 (122)	22 (56)	122 (55)	6/6	✓
E80BE-30208	250	60	80	287	3000	208	80	0.90	74 (279)	60½ (154)	24 (61)	170 (77)	6/6	✓
E80BE-30240	250	60	80	287	3000 ⁺	240	80	0.90	74 (279)	60½ (154)	24 (61)	170 (77)	6/6	✓
E80BE-45208	250	60	80	287	4500	208	80	0.90	81 (305)	60½ (154)	24 (61)	170 (77)	6/6	✓
E80BE-45240	250	60	80	287	4500 ⁺⁺⁺	240	80	0.90	81 (305)	60½ (154)	24 (61)	170 (77)	6/6	✓

All models comply with national energy efficiency regulations.

- *Model is dual-rated. At 208V wattage is 2253.
- **Model is dual-rated. At 208V wattage is 2854.
- ***Model is dual-rated. At 208V wattage is 3380.
- ****Model is dual-rated. At 208V wattage is 4507.

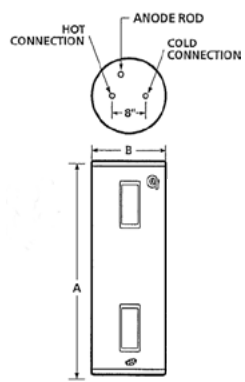
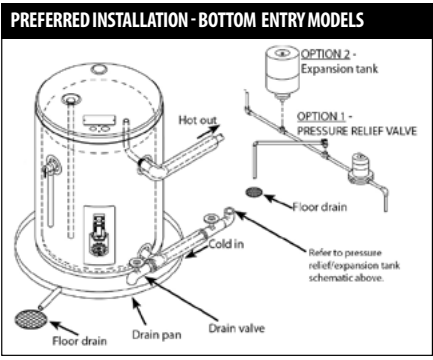
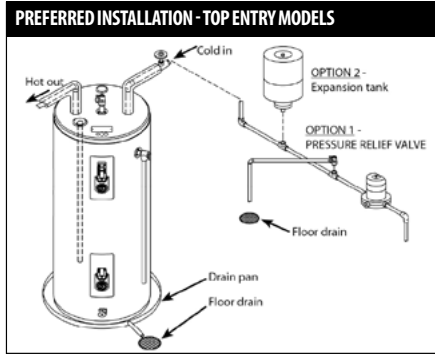

All John Wood electric water heaters listed on this spec sheet have a maximum temperature setting of 150°F.

ProLine® Master Connected Electric Water Heaters

Our ProLine® Master Connected Electric water heaters are designed with iCOMM™ Wi-Fi technology greater control, leak detection and protection to provide homeowners with peace of mind.

Features

Energy Savings

- Meets the NRCAN standby loss requirements

Designed for Performance

- Element dry-fire protection
- Leak detection sensor sounds alarm when water is detected
- Dual elements for fast recovery and reliable operation
- Self-cleaning diptube is made from long-lasting PEX cross-linked polymer and helps to reduce lime and sediment buildup and maximizes hot water output
- Anode rod with stainless steel core that extends the life of the rod, allowing superior tank protection far longer than standard anode rods
- Glass coating provides superior corrosion resistance compared to industry-standard glass lining
- CSA certified and ASME rated T&P relief valve

Serviceability

- Seven-segment electronic control display with diagnostic feedback and two operating modes
- Enhanced-flow solid brass, tamper-resistant ball type drain valve uses a standard female hose fitting that allows for fast and easy draining during maintenance. The drain valve includes an integral screwdriver slot that features a ¼ turn (open/close) radius, which permits full straight-through water flow and a quick and positive shut off
- Optional shut-off valve automatically shuts off incoming cold water when leak is detected (kit #100345338)

Exclusive Design

- Design-listed by Underwriters Laboratories, certified at 300 psi test pressure and 150 psi working pressure and listed according to UL 174 standards governing storage tank-type electric water heaters

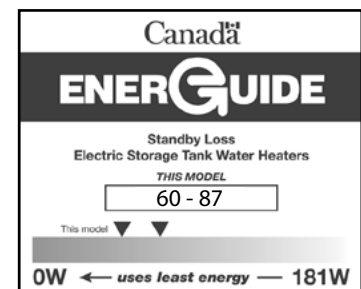

WARRANTY

8 year limited warranty on tank and parts on ProLine® Master models
For complete information, consult written warranty or go to johnwoodwaterheaters.com

SPECIFICATIONS

Model	Capacity			Input		Standby Loss	First Hour Rating	Height to Top of Tank A	Diameter B	Approx. Shipping Weight	BC/ON/QC Compliant
	IG	USG	LITRES	240V	208V						
E50TEME-30	40	50	182	3,000W	2,253W	60	50 (188)	49 ¼ (125)	23 (59)	117 (53)	√
E50TEME-38	40	50	182	3,800W	3,000W	60	53 (202)	49 ¼ (125)	23 (59)	117 (53)	√
E80TEME-45	60	80	287	4,500W	3,500W	87	81 (305)	60 ½ (154)	24 (61)	174 (79)	√
E80TEME-55	60	80	287	5,500W	4,000W	87	85 (322)	60 ½ (154)	24 (61)	174 (79)	√

3/4" water connections on 8" center.

Only available for 240V.

Equipped as dual element only, no single element configurations available.

Dimensions and specifications subject to change without notice in accordance with our policy of continuous product improvement.

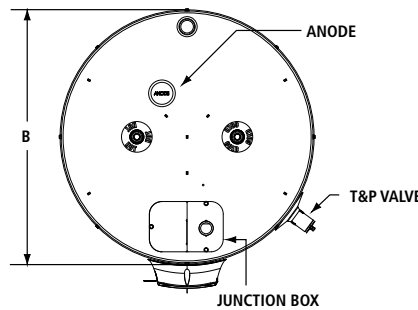
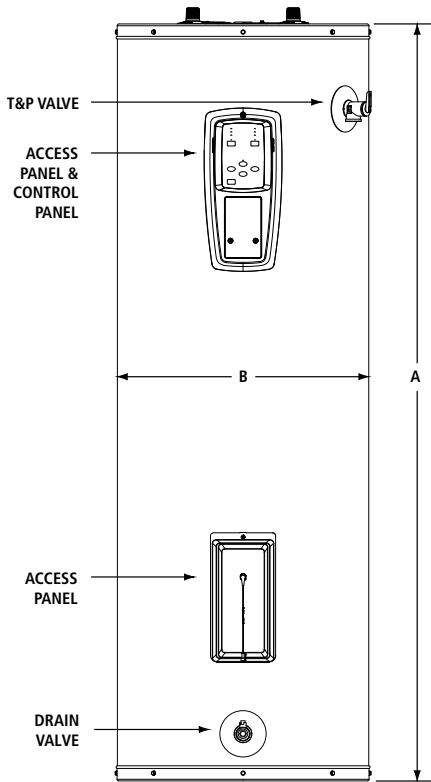

CONTROL PANEL



iCOMM™ SMART CONNECTIVITY

Download the free A. O. Smith app to get started.

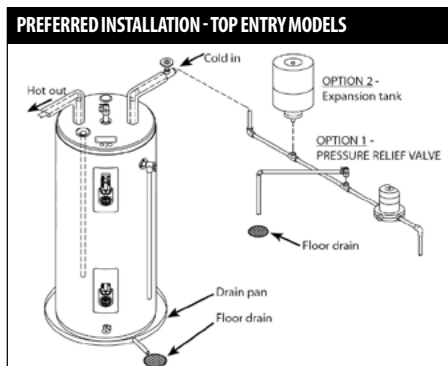

Apple logo and Apple App Store Logo are trademarks of Apple Inc. Google Play and the Google Play logo are trademarks of Google LLC.



Residential Electric Water Heaters

Featuring a variety of models designed for installations in cottages, offices, mobile homes or other applications where space is limited, the SpaceSaver® line of residential electric water heaters provides optimum reliability, performance and energy efficiency.

DESIGNED FOR PERFORMANCE

- Exclusive TankSaver® design
- Glass-lined tanks for longer life
- Meets latest energy efficiency standards
- Factory-installed plastic-lined nipples
- Styropour™ base for added energy efficiency
- Thermostatically controlled long life elements
- CFC-free foam insulation
- Personnel protector covers elements and controls

EASY TO INSTALL AND REPAIR

- Conveniently located T&P and drain valve
- Removable anodes

WARRANTY

- 6 year limited tank warranty
- 1 year limited parts warranty

EXCLUSIVE DESIGN

- The exclusive TankSaver design aids the glass lining process to ensure optimum coverage, and guards tank openings for watertight connections

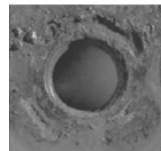

Without TankSaver®

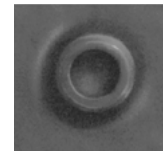

With TankSaver®

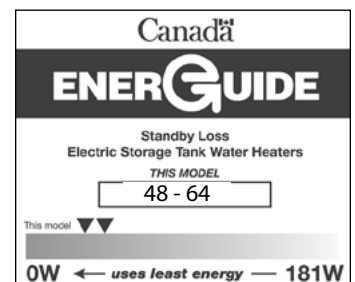

For Technical Information call 888-599-2837. A. O. Smith Enterprises Ltd. reserves the right to make product changes or improvements without prior notice.



Residential Electric Water Heaters

SPECIFICATIONS												
Model	Series	Capacity			Input		Standby Loss	Height	Diameter	Width	Shipping Weight	BC/ON/QC Compliant
		IG	USG	L	WATTS	VOLTS						
TOP ENTRY SINGLE ELEMENT MODELS												
SS025SE15	100	2	2.5	9	1440	120*	N/A	14 1/2 (37)	10 3/8 (26)**	11 3/4 (30)	17 (8)	√
SS04SE15	100	3	4	15	1440	120*	N/A	19 1/4 (49)	10 3/8 (26)**	11 3/4 (30)	20 (9)	√
SS06SE15	100	5	6	23	1440	120*	N/A	18 (46)	15 1/2 (39)***	11 3/4 (30)	24 (11)	√
BOTTOM ENTRY SINGLE ELEMENT MODELS												
SS06SEB15	N/A	5	6	23	1500	120	N/A	15 1/4 (39)	14 1/4 (36)	N/A	35 (16)	√
SS06SEB30	N/A	5	6	23	3000+	240	N/A	15 1/4 (39)	14 1/4 (36)	N/A	35 (16)	√
SS12SEB15	N/A	10	12	45	1500	120	N/A	22 3/4 (58)	16 (41)	N/A	55 (25)	√
SS12SEB30	N/A	10	12	45	3000+	240	N/A	22 3/4 (58)	16 (41)	N/A	55 (25)	√
SS620SSEB-15K	100	14	17	65	1500	120	51	25 1/2 (65)	20 (51)	N/A	65 (30)	√
SS620SSEB-30	100	14	17	65	3000+	240	51	25 1/2 (65)	20 (51)	N/A	65 (30)	√
SS630SSEBN-15K	100	22	27	102	1500	120	48	30 (76)	22 (56)	N/A	101 (46)	√
SS630SSEBN-30	100	22	27	102	3000+	240	48	30 (76)	22 (56)	N/A	101 (46)	√
TOP ENTRY DOUBLE ELEMENT MODELS												
SS640SDE3-15K	100	32	38	144	1500	120	54	50 (127)	20 (51)	N/A	103 (47)	√
SS640SDE3-30X	100	32	38	144	3000	208	54	50 (127)	20 (51)	N/A	103 (47)	√
SS640SDE3-30	100	32	38	144	3000+	240	54	50 (127)	20 (51)	N/A	103 (47)	√
SS650SDE-30	100	40	50	182	3000+	240	53	48 3/4 (124)	22 (56)	N/A	125 (57)	√
SS680TDE-45	100	60	80	287	4500++	240	78	60 1/2 (154)	24 (61)	N/A	170 (77)	√
LOWBOY TOP ENTRY DOUBLE ELEMENT MODELS												
SS630LDE-45X	250	22	27	102	4500	208	53	31 (79)	22 (56)	N/A	96 (44)	ON/QC only
SS630LDE-45	250	22	27	102	4500++	240	53	31 (79)	22 (56)	N/A	96 (44)	ON/QC only
SS640LDE-45X	250	30	36	137	4500	208	62	33 1/2 (85)	24 (61)	N/A	113 (51)	ON/QC only
SS640LDE-45	250	30	36	137	4500++	240	62	33 1/2 (85)	24 (61)	N/A	113 (51)	ON/QC only
SS650LDEN-45	280	40	48	181	4500	240	64	37 3/4 (96)	26 1/2 (67)	N/A	170 (77)	-

*Plug-in model.
 **Depth. Width is 11 3/4 (30).
 ***Depth. Width is 15 3/4 (40).
 +Model is dual-rated. At 208V wattage is 2253.
 ++Model is dual-rated. At 208V wattage is 3380.

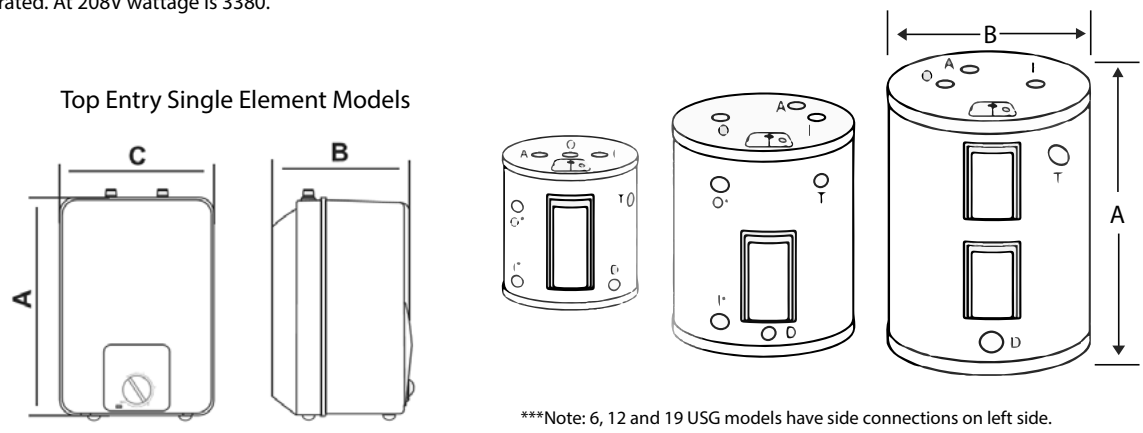

For Technical Information call 888-599-2837. A. O. Smith Enterprises Ltd. reserves the right to make product changes or improvements without prior notice.

CHAUFFE-EAU VOLTEX^{MD} AL INTELLIGENT HYBRIDE ÉLECTRIQUE – POMPE À CHALEUR, À DÉTECTEUR DE FUITE

Le chauffe-eau hybride électrique-pompe à chaleur Voltex^{MD} AL par A. O. Smith constitue l'option d'efficacité énergétique la plus élevée pour les consommateurs qui souhaitent réduire leur facture d'électricité. En plus de vous faire économiser, le Voltex^{MD} AL incorpore un tout nouveau détecteur de fuite pouvant être combiné à un robinet d'arrêt automatique, pour une plus grande tranquillité d'esprit.

COMMENT ÇA MARCHE ?

Absorbe la chaleur de l'air ambiant et la transmet à l'eau à l'aide d'une pompe à chaleur

- La pompe à chaleur est intégrée sous le couvercle supérieur du chauffe-eau
- Les éléments électriques s'activent uniquement si le mode correspondant est sélectionné ou lors d'une grande demande en eau chaude

EFFICACITÉ EXCEPTIONNELLE

- Efficacité améliorée atteignant 4,02 UEF (Facteur énergétique unifié), réduction potentielle du coût de chauffage de l'eau jusqu'à 75 %*
- La pompe à chaleur peut extraire la chaleur de l'air ambiant jusqu'à une température de 2°C (37°F)
- Certification ENERGY STAR®

MODULE INTELLIGENT ICOMM^{MC}

- Surveillance et réglage du chauffe-eau avec l'application gratuite A. O. Smith
- Connectivité Wi-Fi ou directement par Bluetooth^{MD}
- Envoi d'alertes et de notifications

PROTECTION CONTRE LES FUITES

- Anode sacrificielle électrifiée: l'intensité de la protection s'adapte aux conditions de l'eau pour prolonger la durée de vie du chauffe-eau
- Le module ajuste le taux d'épuisement de l'anode: procure au chauffe-eau une protection nettement plus longue par rapport à une anode passive standard
- Le module envoie une notification lorsque l'anode est entièrement épuisée et qu'elle doit être remplacée
- Détecteur de fuite intelligent: déclenche l'envoi d'une notification pouvant éviter un dégât d'eau
- Robinet d'arrêt automatique pour une protection supérieure (kit d'accessoire **100345338**)
- Les notifications sont générées par le module iCOMM^{MC} et transmises à l'appli A. O. Smith

FONCTIONNEMENT SILENCIEUX

- Étonnamment silencieux: 45 dBA

OPTIONS D'INSTALLATION

- Raccords d'eau sur le dessus ou l'avant
- Aucun dégagement latéral et à l'arrière: parfait dans un petit espace
- Adaptateurs d'apport d'air intégrés: pour installations dans un espace confiné
- Choix idéal pour le sous-sol ou au garage: la pompe à chaleur transfère la chaleur de l'air ambiant vers l'eau tout en déshumidifiant l'air

COMMANDE ÉLECTRONIQUE

- Conviviale interface numérique: réglage facile de la température et du mode de fonctionnement, codes diagnostiques clairs

GARANTIE LIMITÉE DE 10 ANS

- Pour des informations complètes, consultez la garantie écrite ou rendez-vous sur hotwatercanada.ca



Faible teneur en plomb



ENERGY STAR



LISTED



*Comparaison d'un Voltex^{MD} AL à pompe à chaleur de 80 USG par rapport à un chauffe-eau électrique standard de même capacité pré-2015, avec taux de conversion FE / FEU du DoE américain et tarif électrique de 0,14 \$ par kWh. Les économies réalisées peuvent varier.

Modèle	Capacité		Facteur énergétique uniforme (UEF)	First Hour Rating	Dimensions po (cm)							Poids approx. à l'expédition lb (kg)
	USG	L			USG (L)	A	B	C	D	E	F	
HPTS-50	50	189	3,80	65 (246)	63 (160)	22 (56)	40 ½ (103)	3 ¾ (9.5)	8 (20)	43 ½ (136)	48 (122)	196 (89)
HPTS-66	66	250	4,02	82 (310)	61 ½ (156)	26 ½ (67)	38 ¼ (97)	4 (10)	8 (20)	41 ¼ (105)	46 (115)	284 (129)
HPTS-80	80	303	3,88	95 (360)	69 (175)	26 ½ (67)	46 ½ (118)	4 (10)	8 (20)	50 ½ (128)	54 ½ (138)	302 (137)

Nécessite un disjoncteur de 30 ampères.
Option de raccord T&P sur le dessus non offerte.

PLUSIEURS MODES DE FONCTIONNEMENT

Sélectionnez le mode qui convient en fonction de vos besoins en eau chaude, des économies recherchées ou de la température ambiante

- Hybride (par défaut): sélection automatique du mode Pompe à chaleur ou Électrique pour maximiser le volume d'eau produit et les économies d'énergie
- Pompe à chaleur: efficacité énergétique maximale
- Électrique: taux de production d'eau chaude maximal
- Vacances: fonctionnement minimal lors d'une absence prolongée

CONNECTIVITÉ INTELLIGENTE iCOMM^{MC}

Téléchargez l'application gratuite A. O. Smith !



AUTRES AVANTAGES

- Boîte de jonction à l'avant pour faciliter l'accès
- Isolant en mousse sans CFC: préserve l'environnement
- Robuste robinet de vidange en laiton à débit élevé
- Soupape de sûreté T&P certifiée CSA et conforme ASME

EXIGENCES D'INSTALLATION

- Nécessite un moyen d'évacuation de la condensation non acide: drain de plancher ou pompe à condensation
- Alimentation électrique: circuit exclusif de 30 A, 208/240VCA 4500/3380W 50/60Hz monophasé

Le logo Apple et le logo Apple App Store sont des marques commerciales d'Apple Inc.
Google Play et le logo Google Play sont des marques commerciales de Google LLC.

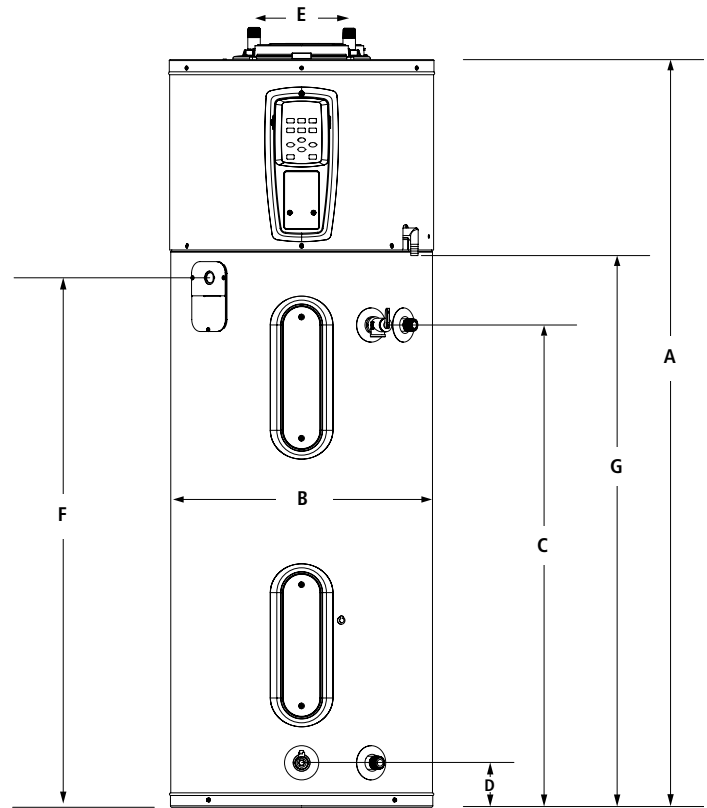

S'INSTALLE DANS UN ESPACE CONFINÉ DE 450PI³: VOLUME 35 % MOINDRE QUE CELUI REQUIS POUR LES PRODUITS CONCURRENTS

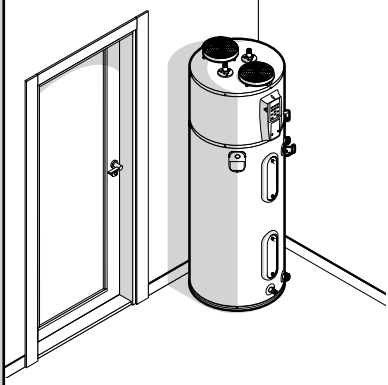
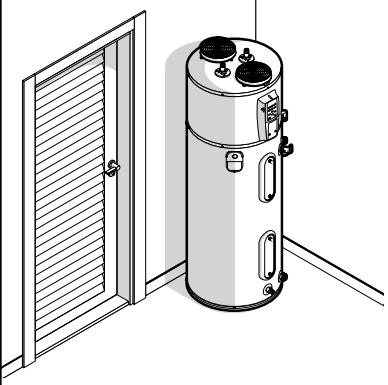
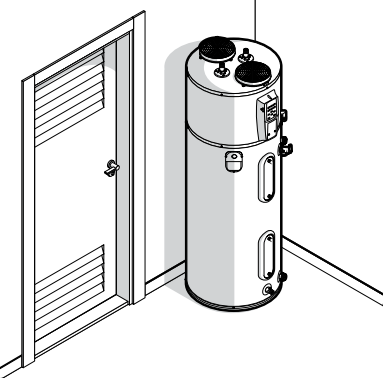
			
Configuration	Espace confiné	Porte persienne pleine hauteur	Porte persienne partielle (haut et bas) ^{1,2}
Espace minimal (pi³)	450	84	84
Exemple de dimensions P x L x H (pi)	6 x 7,5 x 10	3 x 2,8 x 10	3 x 2,8 x 10

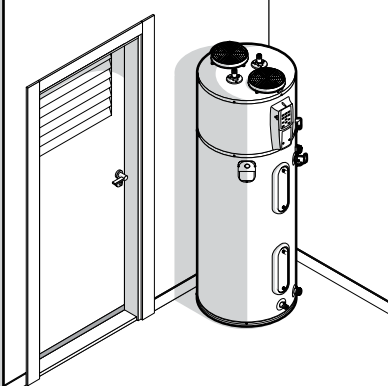
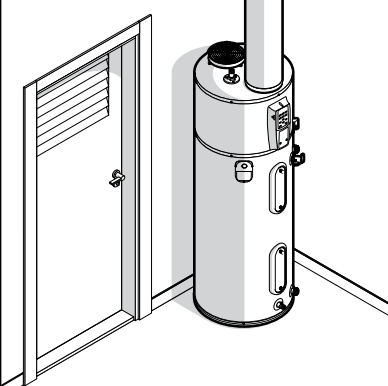
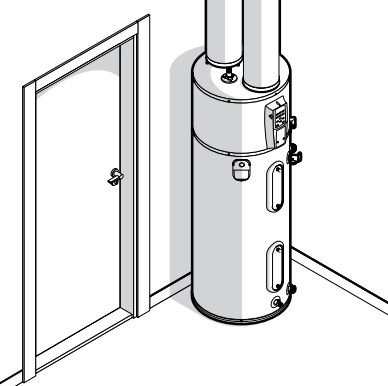
			
Configuration	Porte persienne partielle (haut) et ouverture au bas ^{1,3,4}	Conduit d'apport d'air OU d'évacuation et porte persienne partielle OU ouverture au bas ^{1,3,4,5}	Conduits d'apport d'air ET d'évacuation ⁵
Espace minimal (pi³)	84	Aucun espace minimal requis	Aucun espace minimal requis
Exemple de dimensions P x L x H (pi)	6 x 7,5 x 10		

¹Taille minimale de l'ouverture à lattes: surface libre de 130 po² chacune.

²Porte à deux ouvertures à lattes: une au haut de la porte et la seconde près du plancher.

³Ouverture au bas de la porte: hauteur minimale de 0,75 po et surface libre d'au moins 18 po².

⁴Porte à une seule ouverture à lattes: au haut de la porte.

⁵Compatible avec des conduits d'air de divers diamètres, rigides ou flexibles. Consulter le manuel pour plus de détails à ce sujet.

ProLine® & ProLine® Master Atmospheric Vent

Features

Designed for Performance

- ProLine® and ProLine® Master models are residential water heaters with commercial-grade quality
- Turbulator dip tube reduces sediment build-up at the bottom of the tank
- Thermopile design provides robust pilot to withstand down drafts and environmental conditions
- Easy temperature adjustments
- Robust 1/4" pilot tubing
- Glass lining provides superior protection against tank corrosion
- 3/4" side taps on 75 USG model for combination applications

Serviceability

- Easy-to-access combustion chamber
- Conveniently located T&P and drain valve for ease of installation and serviceability
- Piezoelectric ignitor allows for push-button pilot lighting
- Top mounted heavy duty anode rod for added tank protection
- LED indicator:
 - gives visual confirmation that pilot is on by flashing continuously
 - provides diagnostics and troubleshooting

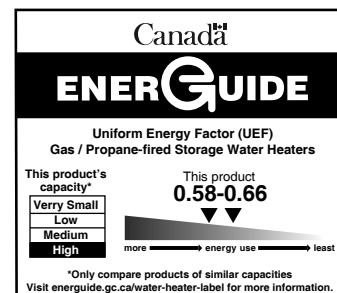

WARRANTY

6 year limited tank and parts on ProLine® models
8 year limited tank and parts on ProLine® Master models
2 or 4 year tank warranty extension kits are available for 6 year models (except 75G models)

PERFORMANCE

Model	Series	Capacity	Input †	Maximum Certified Altitude	Recovery Rate at 90°F Temperature Rise	First Hour Rating	UEF	Warranty Tank/Parts
		USG (L)	BTU/h	FT (M)	GPH (LPH)	GPH (LPH)		Years
NATURAL GAS								
AV30NR	400/401	30 (114)	32,000	10,100 (3,078)	32 (121)	55 (208)	0.60	6/6
AV40N	400/401	40 (151)	40,000	10,100 (3,078)	41 (155)	67 (254)	0.58	6/6
AV40TN	400/401	40 (151)	40,000	10,100 (3,078)	42 (159)	70 (265)	0.66	6/6
AV50N	400/401	50 (189)	40,000	10,100 (3,078)	43 (163)	93 (352)	0.62	6/6
AV50TN	400/401	50 (189)	40,000	10,100 (3,078)	42 (159)	88 (333)	0.62	6/6
AV60N	400/401	60 (227)	52,200	10,100 (3,078)	54 (204)	104 (394)	0.59	6/6
AV75N*	400/401	75 (284)	75,100	7,700 (2,347)	80 (303)	125(473)	0.60	6/6
NATURAL GAS								
AV40NM	400/401	40 (151)	40,000	10,100 (3,078)	41 (155)	67 (254)	0.62	8/8
AV50NM	400/401	50 (189)	40,000	10,100 (3,078)	43 (163)	93 (352)	0.61	8/8

Propane models sub N with P. Natural gas models are series 400. Propane models are series 401.
 All models comply with national energy efficiency regulations.
 *Model has side connections
 † Propane Gas – 36,000 for the 50 gallon short, 37,000 for the 50 gallon tall, & 36,000 for 40 gallon models and 29,000 input for 30 gallon models.

DIMENSIONS & SHIPPING WEIGHT

Model	Installation Height	Height to Top of Tank	Tank Diameter	Height to Gas Inlet	Cold Connection to Hot Connection	Height to T&P	Drafthood Connector Diameter	Shipping Weight
	A IN (CM)	B IN (CM)	C IN (CM)	D IN (CM)	E IN (CM)	F IN (CM)	IN	LB (KG)
AV30NR	50 ¼ (128)	46 ¾ (119)	20 (51)	14 (35)	8 (20)	40 (102)	3 or 4	108 (49)
AV40N / AV40NM	51 ½ (131)	47 ¾ (121)	22 (56)	13 (33)	8 (20)	41 (104)	3 or 4	135 (61)
AV40TN	61 ¾ (157)	58 ¼ (148)	20 (51)	13 (33)	8 (20)	51 ¾ (131)	3 or 4	150 (68)
AV50N / AV50NM	53 ¼ (135)	49 ½ (126)	24 (61)	13 (33)	8 (20)	42 ½ (108)	3 or 4	175 (79)
AV50TN	61 (155)	57 ¼ (145)	22 (56)	13 (33)	8 (20)	50 ¼ (128)	4	165 (75)
AV60N	62 ¾ (159)	59 (150)	24 (61)	13 (33)	8 (20)	51 ½ (131)	4	205 (93)
AV75N	61 (155)	57 ¼ (145)	26 ½ (67)	14 ¾ (37)	8 (20)	50 ¼ (128)	4	273 (124)

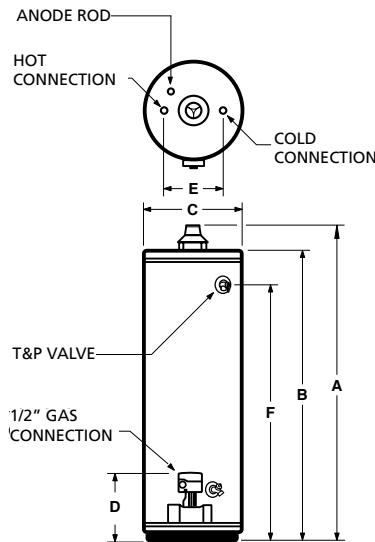
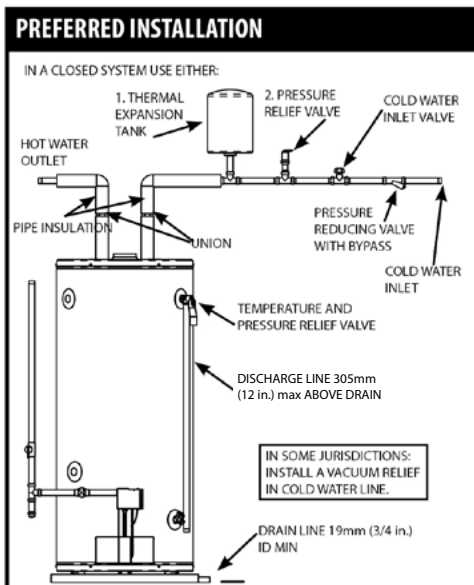

ProLine® XE Atmospheric Vent

Features

Energy Savings

- Exceed NRCan energy efficiency standards
- Built-in heat traps on the water inlet and outlet reduce the amount of heat lost through piping

Designed for Performance

- ProLine® XE models are residential water heaters with commercial-grade quality
- Flue damper for increased energy efficiency and performance
- 24 Volt Gas Valve offers:
 - Diagnostic capabilities
 - Monitoring of damper to ensure proper operation and safety
 - Spark ignition eliminating the need for a standing pilot
- Robust 1/4" pilot tubing
- Durable brass drain valve
- Turbulator dip tube reduces sediment build-up at bottom of the tank
- Glass lining provides superior protection against tank corrosion
- Plugs into a standard 110/120V outlet (10 ft. power cord included)

Serviceability

- Easy-to-access Combustion chamber
- Conveniently located T&P and drain valve for ease of installation and serviceability
- Top mounted heavy duty anode rod for added tank protection

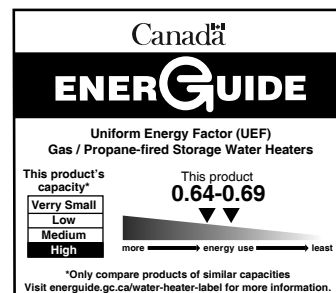

WARRANTY
6 year limited tank and parts

PERFORMANCE

Model	Series	Capacity	Input*	Maximum Certified Altitude	Recovery Rate at 90°F Temperature Rise	First Hour Rating	UEF	Warranty Tank/Parts
		USG (L)	BTU/h	FT (M)	GPH (LPH)	GPH (LPH)		Years
NATURAL GAS								
JW640S40N-AV-ES2	100/101	40 (151)	40,000	10,100 (3,078)	41 (155)	67 (254)	0.66	6/6
JW640T40N-AV-ES2	100/101	40 (151)	40,000	10,100 (3,078)	41 (155)	67 (254)	0.64	6/6
JW650S40N-AV-ES2	100**	50 (189)	40,000	10,100 (3,078)	41 (155)	81 (307)	0.69	6/6
JW650T40N-AV-ES2	100/101	50 (189)	40,000	10,100 (3,078)	41 (155)	81 (307)	0.69	6/6

Propane models sub N with P. Natural gas models are series 100. Propane models are series 101. All models comply with national energy efficiency regulations.

*Propane Gas – 36,000 for the 40 gallon models and 37,000 for the 50 gallon tall models.

**50 USG Short models are not available for Propane.

DIMENSIONS & SHIPPING WEIGHT

Model	Installation Height	Height to Top of Tank	Tank Diameter	Height to Gas Inlet	Hot Connection to Cold Connection	Height to T&P	Draft Hood Connector Diameter	Shipping Weight
	A IN (CM)	B IN (CM)	C IN (CM)	D IN (CM)	E IN (CM)	F IN (CM)	IN	LB (KG)
JW640S40N-AV-ES2	54 (137)	47 ¾ (121)	22 (56)	13 (33)	8 (20)	41 (104)	3 or 4	149 (68)
JW640T40N-AV-ES2	64 ¼ (163)	58 ¼ (148)	20 (51)	13 (33)	8 (20)	51 ¾ (131)	3 or 4	152 (69)
JW650S40N-AV-ES2	55 ¾ (142)	49 ½ (126)	24 (61)	13 (33)	8 (20)	42 ½ (108)	3 or 4	183 (83)
JW650T40N-AV-ES2	63 ½ (161)	57 ¼ (145)	22 (56)	13 (33)	8 (20)	50 ¼ (128)	3 or 4	167 (76)

PREFERRED INSTALLATION

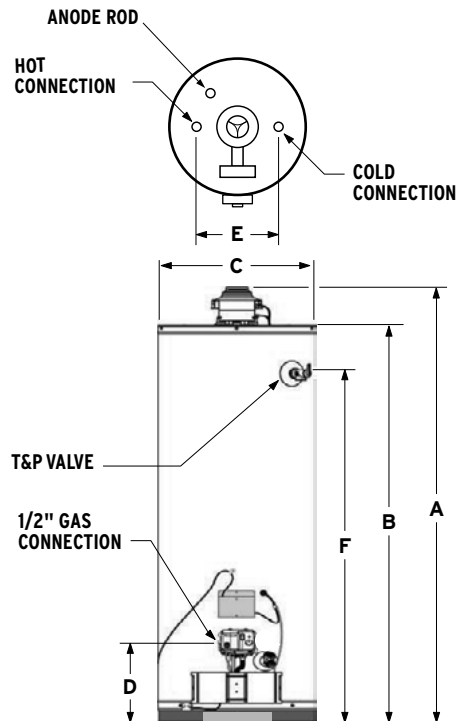
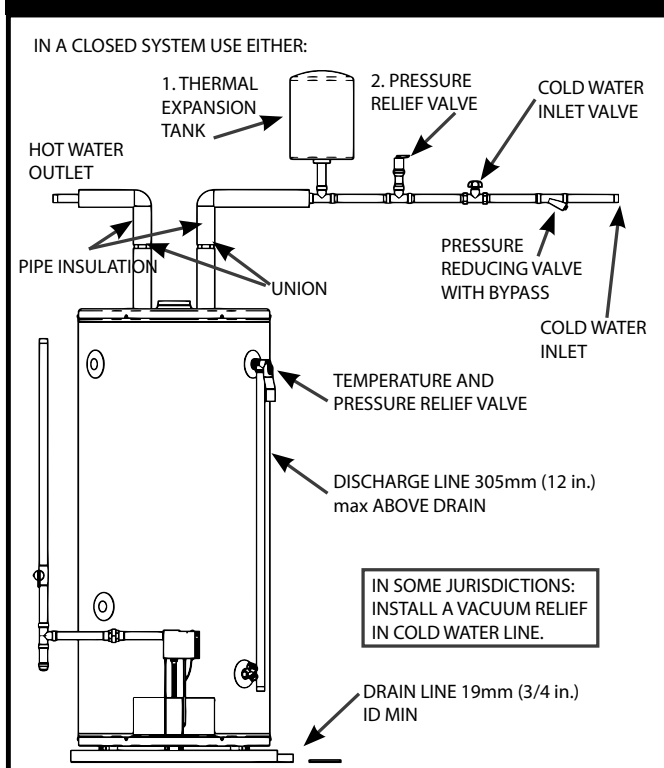

Maximum Hydrostatic Working Pressure: 150 PSI.

ProLine® XE Power Vent

Features

Energy Savings

- Industry-leading energy efficient power vent, with up to a 0.73 UEF
- 2" CFC-free foam insulation to improve energy efficiency
- Built-in heat traps on the water inlet and outlet reduce the amount of heat lost through piping
- Exceeds NRCan energy efficiency standards

Designed for Performance

- ProLine®XE models are residential water heaters with commercial-grade quality
- Easy to install with a 3-position rotatable blower
- Exclusive TankSaver® design to prolong tank life
- Convenient 3/4" side taps for combination applications on 50 USG high-input and 75 USG models
- Suitable for elevations up to 10,100 ft. (3,078 m)
- Available for both natural gas or propane
- Glass lining provides superior protection against tank corrosion

Safety Features

- Sensor detects the presence of flammable vapours and automatically disables the unit, preventing their ignition
- Robust air intake snorkel inhibits flammable vapours from entering the combustion chamber

Serviceability

- State-of-the-art electronic gas control features advanced self-diagnostic capability that makes troubleshooting easy
- Conveniently located T&P and drain valve for ease of installation and serviceability

The Ultimate in Venting Flexibility

- Can be vented with 2", 3" or 4" ULC S636 PVC, CPVC or polypropylene pipe
- Vertical or horizontal venting configurations

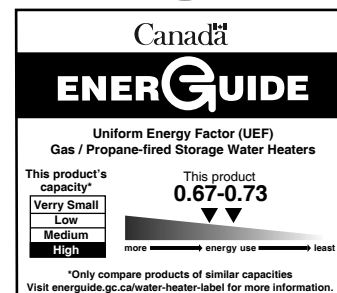

WARRANTY

6 year limited tank and parts
8 year limited tank and parts
2 or 4 year tank warranty extension kits are available for 6 year models

PERFORMANCE								
Model	Series	Capacity	Input	Maximum Certified Altitude	Recovery Rate at 90°F Temperature Rise	First Hour Rating	UEF	Warranty Tank/Parts
		USG (L)	BTU/h	FT (M)	GPH (LPH)	GPH (LPH)		Years
NATURAL GAS								
PV40N	200/201	40 (151)	40,000	10,100 (3,078)	44 (167)	73 (276)	0.67	6/6
PV40TN	200/201	40 (151)	50,000	10,100 (3,078)	50 (189)	90 (341)	0.70	6/6
PV50N	200/201	50 (189)	40,000	10,100 (3,078)	44 (167)	90 (341)	0.72	6/6
PV50TN	200/201	50 (189)	50,000	10,100 (3,078)	50 (189)	96 (363)	0.72	6/6
PV50HIN*	200/201	50 (189)	62,000	10,100 (3,078)	69 (261)	110 (416)	0.73	6/6
PV60N	200/201	60 (227)	42,000	10,100 (3,078)	46 (174)	106 (401)	0.69	6/6
PV75N*	300/301	75 (284)	72,000	10,100 (3,078)	80 (303)	155 (587)	0.69	6/6
NATURAL GAS								
PV50NM	200/201	50 (189)	40,000	10,100 (3,078)	44 (167)	90 (341)	0.72	8/8
PV50HINM*	200/201	50 (189)	62,000	10,100 (3,078)	69 (261)	110 (416)	0.73	8/8

For propane models sub N with P. Natural gas models are series 200/300. Propane models are series 201/301. All models comply with national energy efficiency regulations.

* Model has side connections

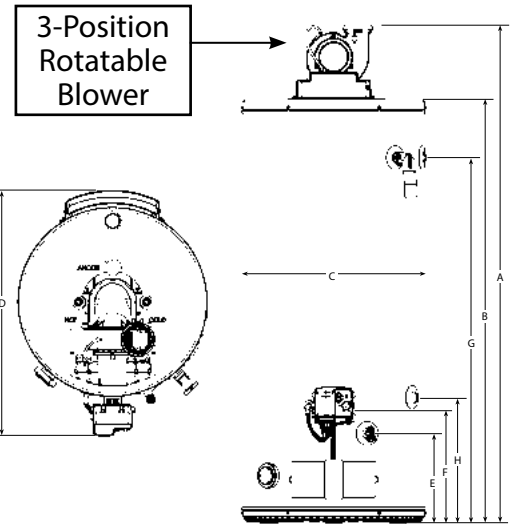

DIMENSIONS & SHIPPING WEIGHT										
Model	Installation Height	Height to Top of Tank	Tank Diameter	Overall Depth	Height to Drain Valve	Height to Gas Inlet	Height to T&P	Height to Upper Side Connection	Height to Lower Side Connection	Shipping Weight
	A IN (CM)	B IN (CM)	C IN (CM)	D IN (CM)	E IN (CM)	F IN (CM)	G IN (CM)	G IN (CM)	H IN (CM)	LB (KG)
NATURAL GAS										
PV40N	59 (150)	49 1/8 (126)	22 (56)	29 1/8 (74)	11 (28)	13 1/4 (34)	42 1/2 (108)	N/A	N/A	174 (79)
PV40TN	68 1/2 (174)	59 1/4 (150)	20 (51)	27 1/8 (69)	11 (28)	13 1/4 (34)	53 1/8 (135)	N/A	N/A	176 (80)
PV50N / PV50NM	60 1/8 (153)	50 3/4 (129)	24 (61)	31 1/8 (79)	11 (28)	13 1/4 (34)	43 3/4 (111)	N/A	N/A	198 (90)
PV50TN	68 1/8 (173)	58 3/4 (149)	22 (56)	29 1/8 (74)	11 (28)	13 1/4 (34)	51 3/4 (131)	N/A	N/A	192 (87)
PV50HIN / PV50HINM	61 1/8 (155)	52 (132)	24 (61)	31 1/8 (79)	11 (28)	13 1/4 (34)	44 1/2 (113)	44 1/2 (113)	15 1/4 (39)	212 (96)
PV60N	67 1/4 (171)	57 7/8 (147)	24 (61)	31 1/8 (79)	11 (28)	13 1/4 (34)	50 3/8 (128)	N/A	N/A	216 (98)
PV75N	70 5/8 (179)	61 1/4 (156)	26 (66)	33 1/8 (84)	11 (28)	13 1/4 (34)	53 (135)	53 (135)	15 1/4 (39)	277 (126)

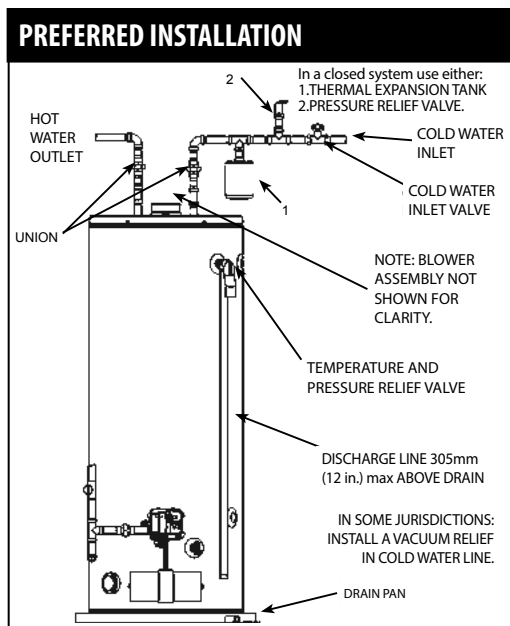

JWPV100 (06-23)

VENT PIPE LENGTHS				
Model	Vent Pipe Diameter IN	Minimum Number of Elbows Required*	Maximum Vent Length with one 90° Elbow FT (M)	Minimum Vent Length with one 90° Elbow FT (M)
PV40N	2	0	50 (15.2)	7 (2.1)
PV40TN	3	0	125 (38.1)	50 (15.2)
PV50N / PV50NM				
PV50TN	4	0	180 (54.9)	125 (38.1)
PV60				
PV50HIN / PV50HINM	3	0	50 (15.2)	7 (2.1)
PV75N	4	0	125 (38.1)	50 (15.2)

* Refer to installation manual for further details.

VENT KITS	
Description	Part Number
3" Vent Kit Includes coupling for blower outlet and termination screens	100112701
4" Vent Termination Kit Includes termination screens	100112700

ProLine® XE Power Direct Vent

Features

Energy Savings

- Exceeds NRCan energy efficiency standards
- Factory installed heat trap nipples

Designed for Performance

- ProLine® XE models are residential water heaters with commercial-grade quality
- Compact design - ideal as a replacement water heater and for closet installations
- Exclusive TankSaver® design to prolong tank life
- Ultra-quiet blower
- Convenient 3/4" side water connections for combination applications on high input 50 USG and 75 USG units (plugs are factory installed)
- Factory installed T&P valve and drip tube
- Glass lining provides superior protection against tank corrosion

Safety Features

- Sealed combustion chamber design, eliminating the need for a flammable vapour sensor
- Zero clearance to combustibles

Serviceability

- State-of-the-art gas control features advanced self-diagnostic capability that makes troubleshooting easy
- Conveniently located T&P and drain valve for ease of serviceability
- Auto-reset temperature switch monitors vent temperature

The Ultimate in Venting Flexibility

- Can be vented with 2", 3" or 4" ULC S636 PVC, CPVC or polypropylene pipe up to 180 equivalent feet (see installation manual for full details)
- Can be installed using a concentric vent kit (see reverse or installation manual for details)

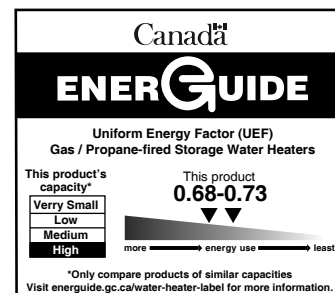

WARRANTY

6 year limited tank and parts
2 or 4 year tank warranty extension kits are available

PERFORMANCE

Model	Series	Capacity	Input	Recovery Rate at 90°F Temperature Rise	First Hour Rating	UEF	Warranty Tank/Parts
		USG (L)	BTU/h	GPH (LPH)	GPH (LPH)		Years
NATURAL GAS							
PDV40N	300/301	40 (151)	40,000	45 (170)	71 (269)	0.68	6/6
PDV50N	300/301	50 (189)	45,000	50 (189)	93 (352)	0.72	6/6
PDV50HIN*	300/301	50 (189)	62,000	73 (276)	100 (379)	0.73	6/6
PDV75N*	300/301	75 (284)	72,000	82 (310)	154 (583)	0.68	6/6

For propane models sub N for P. Natural gas models are series 300. Propane models are series 301. All models rated for installation at altitudes up to 10,100 ft (3,078 m).

*Side connections.

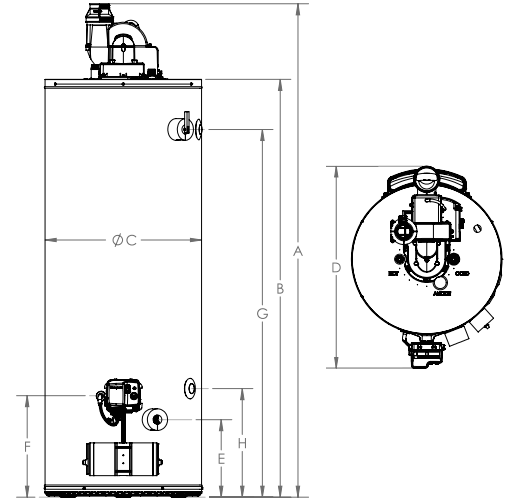

DIMENSIONS & SHIPPING WEIGHT

Model	Installation Height	Height to Top of Tank	Tank Diameter	Overall Depth	Height to Drain Valve	Height to Gas Inlet	Height to T&P	Height to Upper Side Connection	Height to Lower Side Connection	Vent Diameter	Shipping Weight
	A IN (CM)	B IN (CM)	C IN (CM)	D IN (CM)	E IN (CM)	F IN (CM)	G IN (CM)	G IN (CM)	H IN (CM)	IN	LB (KG)
NATURAL GAS											
PDV40N	58 ¼ (148)	49 ½ (126)	22 (56)	29 ⅞ (76)	11 (28)	13 ¼ (34)	42 ⅜ (108)	N/A	N/A	2, 3 or 4	174 (79)
PDV50N	67 ½ (171)	58 ⅞ (150)	22 (56)	29 ⅞ (76)	11 (28)	13 ¼ (34)	51 ¾ (131)	N/A	N/A	2, 3 or 4	192 (87)
PDV50HIN	68 ⅞ (175)	60 ¼ (153)	22 (56)	29 ⅞ (76)	11 (28)	13 ¼ (34)	52 ¾ (134)	52 ¾ (134)	15 ¼ (39)	3 or 4	200 (91)
PDV75N	70 ⅝ (179)	60 ½ (154)	26 (66)	33 ⅞ (86)	11 (28)	13 ¼ (34)	53 (135)	53 (135)	15 ¼ (39)	3 or 4	277 (126)

PREFERRED INSTALLATION

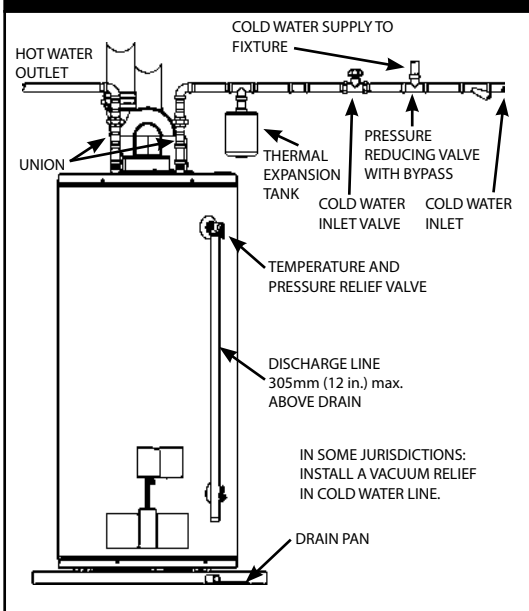

For Technical Information/Warranty:
Call 1-888-479-8324 or
email techsupport@johnwoodwaterheaters.com
www.johnwoodwaterheaters.com

VENT PIPE LENGTHS

Model	Vent Pipe Diameter IN	Minimum Number of Elbows Required*	Minimum Vent Length with One Elbow FT (M)		Maximum Equivalent Vent Length FT (M)	
			Concentric	2 Pipe	Concentric	2 Pipe
PDV40N	2	1	7 (2)	7 (2)	50 (15)	50 (15)
	3	1	7 (2)	7 (2)	100 (30)	125 (38)
	4	1	N/A	50 (15)	N/A	180 (55)
PDV50N	2	1	7 (2)	7 (2)	50 (15)	50 (15)
	3	1	7 (2)	7 (2)	100 (30)	125 (38)
	4	1	N/A	50 (15)	N/A	180 (55)
PDV50HIN	3	1	7 (2)	7 (2)	45 (14)	50 (15)
	4	1	N/A	50 (15)	N/A	125 (38)
PDV75N	3	1	7 (2)	7 (2)	30 (9)	50 (15)
	4	1	N/A	50 (15)	N/A	125 (38)

* Refer to installation manual for further details.

OPTIONAL KITS

Description	Part Number
2" concentric vent kit	100112869
3" concentric vent kit	100111100
High ambient kit	100308923

ProLine® Direct Vent

Features

Designed for Performance

- ProLine® models are residential water heaters with commercial-grade quality
- Thermopile design provides robust pilot to withstand down drafts and environmental conditions
- Easy temperature adjustments
- 90" coaxial vent supplied with water heater
- Glass lining provides superior protection against tank corrosion
- Factory-installed plastic-lined nipples with heat traps
- Automatic gas control
- CFC-free foam insulation
- 50 USG high input model available for combination applications
- Suitable for closet installations
- 3/4" side taps available on 50 USG high input model for combination applications

Safety Features

- Sealed combustion system, eliminates the need for a Flammable Vapour sensor

Serviceability

- Easy-to-access combustion chamber
- Conveniently located T&P and drain valve for ease of installation and serviceability
- LED indicator:
 - Gives visual confirmation that pilot is on by flashing continuously
 - Provides diagnostics and troubleshooting
- Piezoelectric ignitor allows for push-button pilot lighting
- Top mounted heavy duty anode rod for added tank protection

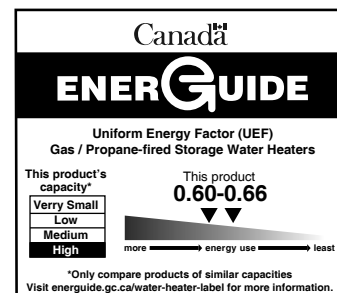

WARRANTY

6 year limited tank and parts
2 or 4 year tank warranty extension kits are available

PERFORMANCE								
Model	Series	Capacity	Input	Maximum Certified Altitude	Recovery Rate at 90° F Temperature Rise	First Hour Rating	UEF	Warranty Tank/Parts
		USG (L)	BTU/h	FT (M)	GPH (LPH)	GPH (LPH)		Years
DV40N	300/301	40 (151)	38,000	7,700 (2,347)	42 (159)	72 (273)	0.60	6/6
DV50N	300/301	50 (189)	40,000	7,700 (2,347)	43 (163)	91 (344)	0.66	6/6
DV50HIN*	300/301	50 (189)	47,000	7,700 (2,347)	51 (193)	92 (348)	0.65	6/6

For propane models sub N with P. Natural gas models are series 300. Propane models are series 301. All models comply with national energy efficiency regulations.
 *Model has side connections.

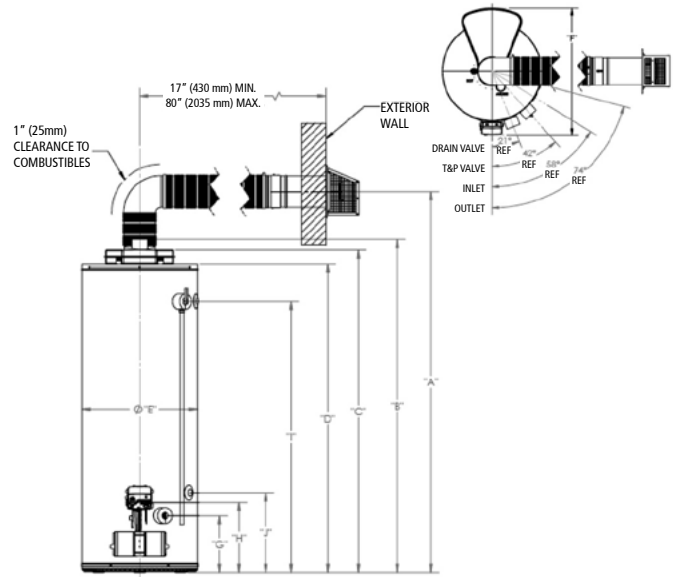

DIMENSIONS & SHIPPING WEIGHT													
Model	Height to Center of Vent	Height to Top of Flue Outlet	Height to Top of Air Box	Height to Top of Heater	Diameter	Overall Depth	Height to Drain	Height to Gas Inlet	Height to T&P	Height to Side Tap (Hot Out)	Height to Side Tap (Cold In)	Shipping Weight	
	A IN (CM)	B IN (CM)	C IN (CM)	D IN (CM)	E IN (CM)	F IN (CM)	G IN (CM)	H IN (CM)	I IN (CM)	I IN (CM)	J IN (CM)	LB (KG)	
DV40N	64 (163)	54 3/8 (138)	52 1/2 (133)	49 3/8 (126)	22 (56)	29 (74)	10 3/4 (27)	13 1/4 (34)	42 3/8 (108)	N/A	N/A	178 (81)	
DV50N	73 (185)	63 3/8 (162)	61 3/4 (157)	58 7/8 (150)	22 (56)	29 (74)	10 3/4 (27)	13 1/4 (34)	51 3/8 (131)	N/A	N/A	200 (91)	
DV50HIM*	74 (188)	64 3/8 (164)	62 7/8 (160)	60 (152)	22 (56)	29 (74)	10 3/4 (27)	13 1/4 (34)	52 3/8 (134)	52 3/8 (134)	15 1/4 (39)	215 (98)	

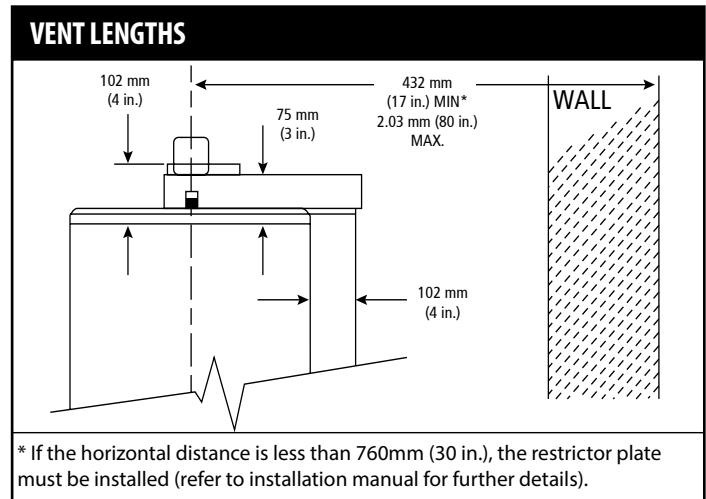
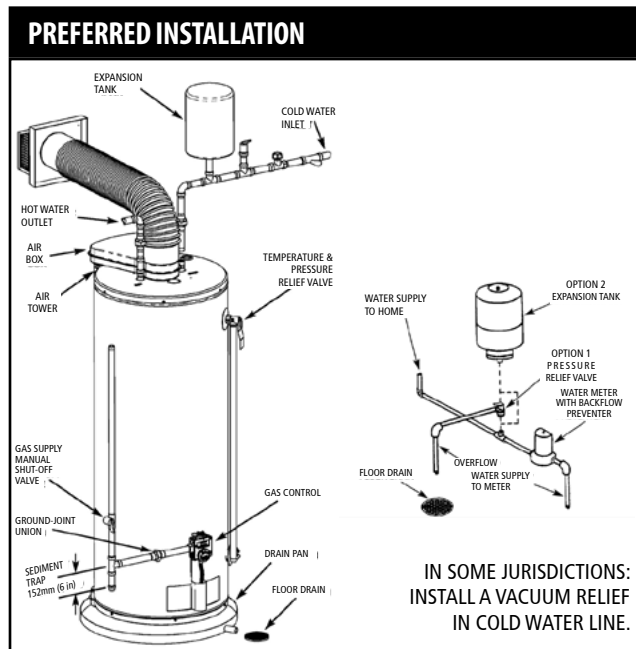

Refer to the installation manual for complete installation and venting requirements.



Envirosense® Power Vent

94% Condensing Gas Water Heater

The Envirosense® Power Vent is an ENERGY STAR® qualified, 50-gallon, 76,000 BTU gas water heater, equipped with a fully submerged, spiral-shaped condensing heat exchanger. This design provides much greater heat transfer surface than a standard straight flue tube, resulting in 94% thermal efficiency and higher hot water output than standard 78% efficient water heaters. With a 22" diameter, the Envirosense Power Vent can be installed in less space than a 75-gallon unit and delivers greater recovery and lower operating costs. The Envirosense Power Vent is so advanced, it delivers hot water shower after shower... at a continuous flow of over 3 gallons per minute.*

POWER VENT DESIGN FOR INSTALLATION VERSATILITY

- Modular blower, with 120V, 60Hz electrical system (5 amps or less), 6-foot cord with standard 3-prong connector
- Combined horizontal and vertical vent runs terminating through outside wall, using ULC S636 PVC, CPVC or polypropylene pipe as follows:
 - 2" pipe allows vent runs up to 25 equivalent feet
 - 3" pipe allows vent runs up to 65 equivalent feet
 - 4" pipe allows vent runs up to 125 equivalent feet
- Supplied with PVC pipe and elbows to connect heat exchanger outlet to blower, including condensate elbow and drain, and ULC S636 PVC Vent Attenuation Assembly (VAA)

SIDE-MOUNTED TAPS FOR RECIRCULATING SYSTEMS

- Hot and cold side taps allow for combination systems for water heating plus space heating, radiant floor heating or other applications requiring a recirculating hot water loop
- Plugs for recirculating taps are shipped with water heater

Intelli-Vent™ GAS CONTROL WITH SILICON NITRIDE HOT SURFACE IGNITER

- Premium-grade hot surface igniter eliminates standing pilot
- Electronic circuitry provides superior system diagnostic capabilities plus extremely precise temperature control

COMMERCIAL-GRADE GLASS LINING WITH TWO MAGNESIUM ANODE RODS

- Superior protection against tank corrosion
- Glass lining protects all water side tank surfaces plus inside of internal heat exchanger exposed to condensate

WARRANTY**

- 6 year limited tank warranty
- 6 year limited parts warranty

AVAILABLE IN NATURAL GAS ONLY

* 3.21 GPM continuous flow, based on 65°F/18°C inlet water temperature and 110°F/43°C outlet water temperature. **In residential applications. Reduced warranty in commercial applications.



For Technical Information call 888-599-2837. A. O. Smith Enterprises Ltd. reserves the right to make product changes or improvements without prior notice.

ENVPV100 (03-23)



Envirosense® Power Vent

94% Condensing Gas Water Heater

PERFORMANCE									
Model	Series	Capacity		Maximum Certified Altitude	Input	Recovery Rate at 90°F Temperature Rise	Thermal Efficiency	UEF	BC Compliant
		USG	L						
NATURAL GAS									
6G5076NVC02*	130	50	189	5,300 (1,615)	76,000	96 (364)	94%	0.88	√

DIMENSIONS & SHIPPING WEIGHT														
Model	Installation Height	Height to Top of Tank	Height to T&P	Height to Upper Side Connection	Height to Lower Side Connection	Height to Drain Valve	Height to Thermostat	Tank Diameter	Hot Connection to Cold Connection	Water Connection Depth From Front of Tank	Overall Depth	Top Water Connections	Side Water Connections	Shipping Weight
	A IN (CM)	B IN (CM)	C IN (CM)	C IN (CM)	D IN (CM)	E IN (CM)	F IN (CM)	G IN (CM)	H IN (CM)	J IN (CM)	K IN (CM)	IN NPT	IN NPT	LB (KG)
NATURAL GAS														
6G5076NVC02*	71 (180)	68 3/8 (174)	52 (132)	52 (132)	21 (53)	9 1/8 (23)	12 (30)	22 (56)	8 (20)	15 3/4 (40)	27 (69)	3/4	3/4	225 (102)

Natural gas only.
 *Model has side connections.

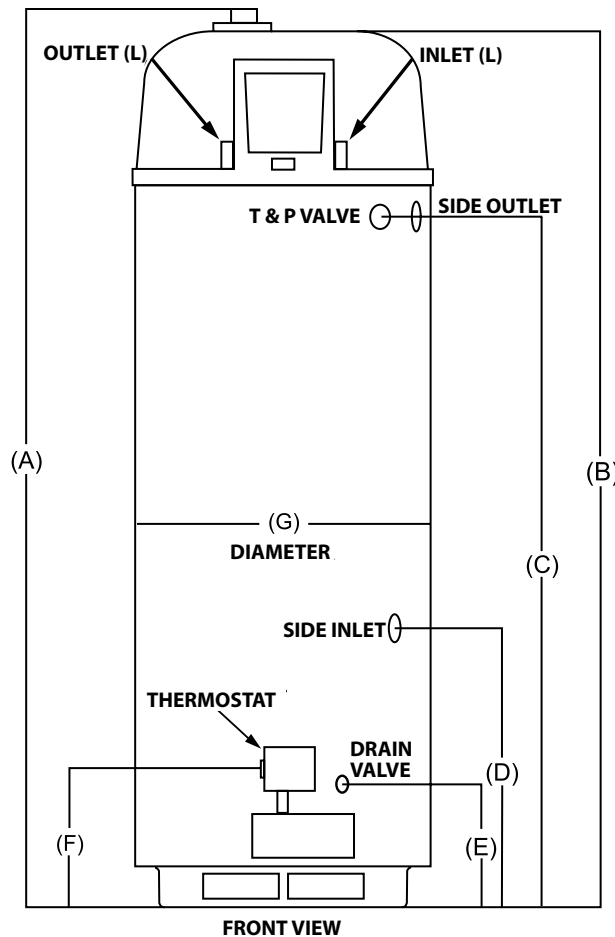
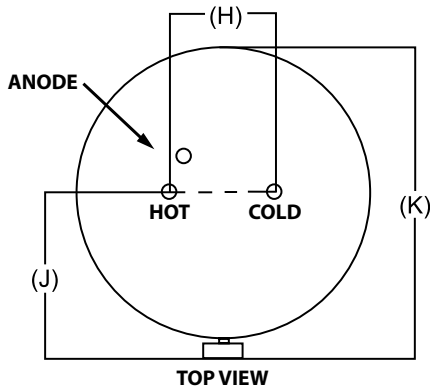

For Technical Information call 888-599-2837. A. O. Smith Enterprises Ltd. reserves the right to make product changes or improvements without prior notice.



Envirosense® Power Direct Vent

96% Efficient Gas Water Heater

The 100,000 BTU ENERGY STAR® qualified Envirosense® Power Direct Vent gas water heater is equipped with a fully submerged, spiral-shaped condensing heat exchanger and 50 or 75 gallons of storage capacity. This design provides much greater heat transfer surface than a standard straight flue tube, resulting in 96% thermal efficiency and higher hot water output* than comparable 80% efficient water heaters.

POWER DIRECT VENT DESIGN

- Top fired burner
- Combined horizontal and vertical vent runs terminating through outside wall or roof, using ULC S636 PVC, CPVC or polypropylene pipe as follows:
 - 2" pipe allows vent runs up to 45 equivalent feet
 - 3" pipe allows vent runs up to 128 equivalent feet

INTELLIGENT CONTROL SYSTEM WITH TOUCH SCREEN DISPLAY

- Exclusive touch display control system
- Precise temperature control
- Advanced diagnostics

AVAILABLE IN NATURAL GAS OR PROPANE

SIDE-MOUNTED TAPS FOR RECIRCULATING SYSTEMS

- Hot and cold side taps allow for combination systems for water heating plus space heating, radiant floor heating or other applications requiring a recirculating hot water loop
- Plugs for recirculating taps are factory installed

GLASS LINED TANK WITH TWO MAGNESIUM ANODE RODS

- Provides superior protection against corrosion
- Commercial-grade glass lining protects all water side tank surfaces plus inside of internal heat exchanger exposed to condensate

WARRANTY**

- 6 year limited tank warranty
- 6 year limited parts warranty

* 4.3 GPM continuous flow, based on 65°F/18°C inlet water temperature and 110°F/43°C outlet water temperature.
 **In residential applications. Reduced warranty in commercial applications.



50 Gallon Model Shown



For Technical Information call 888-599-2837. A. O. Smith Enterprises Ltd. reserves the right to make product changes or improvements without prior notice.

GPDVENV0609 (03-23)



Envirosense® Power Direct Vent

96% Efficient Gas Water Heater

PERFORMANCE

Model	Series	Capacity		Maximum Certified Altitude	Input	Recovery Rate at 90°F Temperature Rise	Thermal Efficiency	UEF	BC Compliant
		USG	L						
NATURAL GAS									
6G50100NPDVH02*	300/301	50	189	10,100 (3,078)	100,000	128 (485)	96%	0.88	√
6G75100NPDVH02*	300/301	75	284	10,100 (3,078)	100,000	128 (485)	96%	0.86	√

DIMENSIONS & SHIPPING WEIGHT

Model	Height to Top of Tank	Height to T&P	Height to Upper Side Connection	Tank Diameter	Height to Lower Side Connection	Height to Drain Valve	Outlet to Inlet	Top Water Connections	Side Water Connections	Gas Connection	Shipping Weight
	A IN (CM)	B IN (CM)	B IN (CM)	C IN (CM)	D IN (CM)	E IN (CM)	F IN (CM)	IN NPT	IN NPT	IN NPT	LB (KG)
NATURAL GAS											
6G50100NPDVH02*	66 ¾ (170)	49 ¼ (125)	49 ¼ (125)	22 (56)	15 ¾ (40)	3 (8)	8 (20)	¾	¾	½	255 (116)
6G75100NPDVH02*	65 ¼ (166)	45 ⅝ (116)	45 ⅝ (116)	27 ¾ (71)	16 (41)	3 ¾ (10)	8 (20)	1	¾	½	382 (173)

For propane models sub N for P. Natural gas models are series 140. Propane models are series 141.
 Inlet and outlet connections: 3/4" male for 6G50100NPDVH02 and 1" for 6G75100NPDVH02
 Circulation loop connections: 3/4" female
 Gas inlet: 1/2"
 Maximum Supply Pressure: 14 inches W.C. (3.48kPa)
 Minimum Supply Pressure for Natural Gas: 3.50 inches W.C. (.87kPa)
 Minimum Supply Pressure for Propane Gas: 8.00 inches W.C. (1.99kPa)
 Minimum pressure must be maintained under both load and no load (dynamic and static) conditions.
 Electrical Characteristics - 120V, 60Hz, Amperes <5
 *Model has side connections

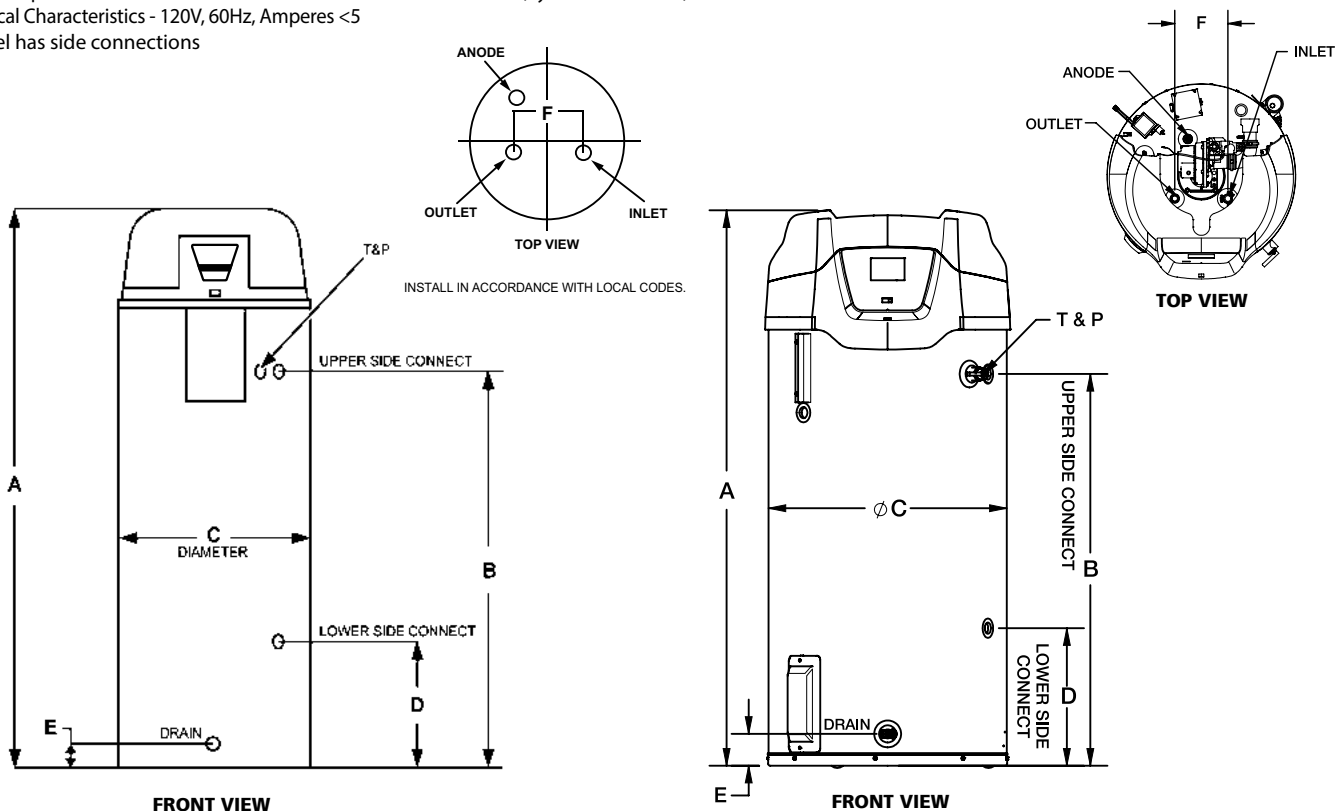

For Technical Information call 888-599-2837. A. O. Smith Enterprises Ltd. reserves the right to make product changes or improvements without prior notice.

GPDVENV0609 (03-23)



Envirosense[®] SF

HIGH-EFFICIENCY RESIDENTIAL GAS WATER HEATERS

Flexible, Powerful & Highly Efficient Gas Water Heaters.

Commercial-grade hot water delivery is now more attainable than ever. The Envirosense SF provides flexible, powerful and highly efficient performance to the everyday home. The fully condensing Envirosense SF design is so advanced, it can deliver continuous hot water at a constant flow of over 2.5 gallons per minute.*

ENERGY STAR[®] QUALIFIED

CONDENSING DESIGN

- High efficiency operation with up to 0.90 Uniform Energy Factor to save money on operating costs

SIDE FIRED GAS BURNER

- Unique side fire design allows for optimal burner placement

HELICAL INTERNAL HEAT EXCHANGER

- Spiral heat exchanger keeps hot combustion gases in the tank longer to lengthen the heat transfer cycle
- Positioned in the center of the tank for more even heat distribution
- Spiral design reduces the effect of lime scale and sediment on the heat exchanger to maintain high-efficiency operation over time

POWER VENT AND POWER DIRECT VENT WITH A SINGLE DESIGN

- Combined vertical and horizontal runs terminating through an outside wall. Vents using PVC, CPVC, or polypropylene pipe.
- 2" pipe vents up to 60 equivalent feet
- 3" pipe vents up to 150 equivalent feet

ADVANCED ELECTRONIC CONTROL

- Precise temperature control
- Built-in diagnostics and operational information

SIDE-MOUNTED HOT AND COLD RECIRCULATING TAPS

- Allows Envirosense SF to be installed as part of combination space heating/water heating applications

HEAVY-DUTY ANODIC PROTECTION

- Comes standard with dual sacrificial anodes to protect the tank
- Optional Powered Anode available for enhanced tank protection in all water conditions

GLASS TANK LINING

- Provides superior corrosion resistance compared to industry standard glass lining.

CSA CERTIFIED AND ASME RATED T&P RELIEF VALVE

MAXIMUM HYDROSTATIC WORKING PRESSURE: 150 PSI

AVAILABLE IN NATURAL GAS

CODE COMPLIANCE

- Meets NRCAN and provincial thermal efficiency and standby loss requirements.

DESIGN-CERTIFIED BY CSA

- Certified at 300 psi test pressure and 150 psi working pressure. Listed according to ANSI Z21.10.1 - CSA 4.1 standards governing storage tank-type water heaters.

6-YEAR LIMITED TANK AND PARTS WARRANTY

- For complete information, consult written warranty or go to hotwater.com

*Continuous hot water based on 65,000 BTU unit, 2.8 GPM continuous flow with a 65°F inlet water temperature, 110°F outlet temperature, and installed per the manufacturer's instructions.



MODEL SHOWN ENV-40





Envirosense[®] SF

HIGH-EFFICIENCY RESIDENTIAL GAS WATER HEATERS

MODEL NUMBER	NOMINAL CAPACITY USG (L)	RATED STORAGE VOLUME USG (L)	FIRST HOUR RATING USG (L)	UEF	THERMAL EFFICIENCY	RECOVERY @ 90° RISE GPH (LPH)	BTU INPUT PER HOUR	APPROX. SHIPPING WEIGHT LB (KG)
ENV-40N	40 (151)	39 (147)	86 (325)	0.90	93%	62 (234)	50,000	216 (98.2)
ENV-50N	50 (189)	48 (181)	118 (446)	0.90	93%	81 (306)	65,000	246 (111.8)

Available in natural gas only.
 Top Inlet and outlet connections: 3/4" male NPT. Circulation loop connections: 3/4" female NPT
 Models certified for sea level to 10,100 ft. elevation.

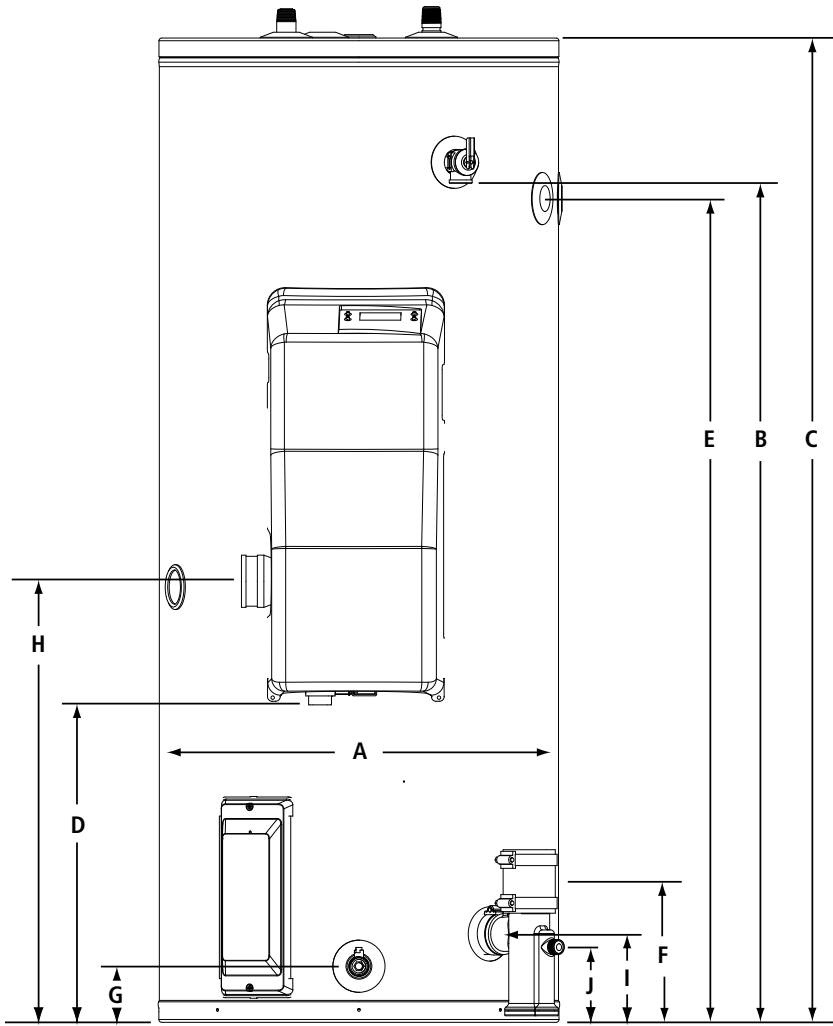

	DESCRIPTION	DIMENSIONS IN (CM)	
		40 GAL	50 GAL
A	DIAMETER	22 (56)	22 (56)
B	HEIGHT TO T&P	38-3/8 (97)	47-3/8 (120)
C	HEIGHT TO TOP	44-7/8 (114)	54-1/4 (138)
D	HEIGHT TO GAS CONNECTION	16-1/2 (42)	17-1/2 (44)
E	HEIGHT TO UPPER SIDE CONNECT	36-3/8 (92)	45-3/8 (115)
F	HEIGHT TO LOWER SIDE CONNECT	8-5/8 (22)	7-7/8 (20)
G	HEIGHT TO DRAIN VALVE	3-7/8 (10)	3 (8)
H	HEIGHT TO AIR INTAKE	22-1/8 (56)	24-1/4 (62)
I	HEIGHT TO EXHAUST	5-3/8 (14)	4-7/8 (12)
J	HEIGHT TO CONDENSATE CONNECTION	5-1/2 (14)	4 (10)
K	OVERALL DEPTH	28-1/2 (72)	28-1/2 (72)
L	WATER CONNECTIONS	8 (20)	8 (20)

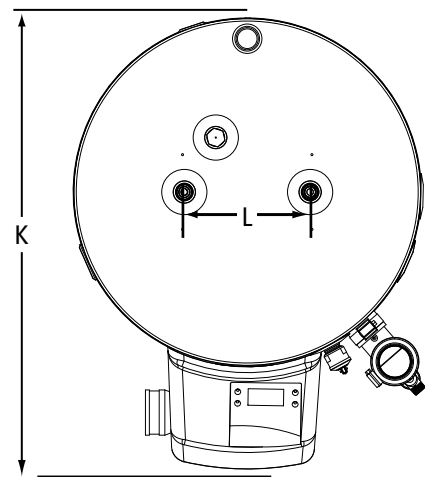

OPTIONAL ACCESSORIES

PART NUMBER	DESCRIPTION
100112869	2" concentric termination kit
100111100	3" concentric termination kit
100187903	2" low-profile termination kit
100187887	3" low-profile termination kit
100112159	Condensate neutralizer kit
100305721	Powered anode kit

ENV40 (04-22)

POLARIS

Polaris™ High-Efficiency Residential Gas Water Heater

The Polaris high efficiency gas water heater is the high performance answer for today's hot water needs. It can provide endless hot water* and can be used for a combination of domestic hot water and space heating.

CONDENSING DESIGN

- Operates at up to 96% thermal efficiency which saves money on operating costs compared to a standard 80% efficient gas water heater
- Helical internal heat exchanger keeps hot combustion gases in the tank longer to transfer more heat into the water

STAINLESS STEEL CONSTRUCTION

- Tank and helical heat exchanger are constructed from 444 stainless steel for excellent corrosion resistance without the need for an anode

WHISPER QUIET OPERATION

- Ultra quiet blower and burner to minimize noise

POWER DIRECT VENT DESIGN

- Direct vent using ULC S636, PVC, CPVC or Polypropylene (solid core only) through a sidewall or roof
- Optional concentric vent kit
- 2" pipe vents up to 52 equivalent feet (100-150k BTU/h inputs)
- 3" pipe vents up to 130 equivalent feet

ADVANCED ELECTRONIC CONTROL

- Large touchscreen display
- Precise temperature control
- Advanced water heater status and diagnostics

MODULATING GAS BURNER

- Modulating burner maintains high efficiency operation at lower input rates

SIDE-MOUNTED HOT AND COLD RECIRCULATING TAPS

- Polaris can be easily installed with a recirculation system or as part of a combined domestic & space heating system

FULLY SERVICEABLE FROM THE FRONT

- Two front access panels expose all serviceable components. Modular components are all easily removed

AVAILABLE IN NATURAL GAS OR PROPANE

CSA CERTIFIED AND ASME RATED T&P RELIEF VALVE

10-YEAR LIMITED TANK AND 1-YEAR PARTS WARRANTY

*When sized appropriately. Model PR50-199 can deliver 6.95 GPM continuous flow, based on 65°F inlet water temperature, 120°F outlet temperature.



For Technical Information call 888-599-2837. A. O. Smith Enterprises Ltd. reserves the right to make product changes or improvements without prior notice.



Polaris™ High-Efficiency Residential Gas Water Heater

PERFORMANCE								
Model	Series	Capacity		Maximum Certified Altitude	Input	Recovery Rate at 90°F Temperature Rise	Thermal Efficiency	Warranty Tank/Parts
		USG	L					
NATURAL GAS								
PR 34-100 N	200	34	129	7,700 (2,437)	100,000	129 (488)	96%	10/1
PR 34-130 N	200	34	129	7,700 (2,437)	130,000	168 (636)	96%	10/1
PR 34-150 N	200	34	129	7,700 (2,437)	150,000	190 (719)	94%	10/1
PR 50-130 N	200	50	189	7,700 (2,437)	130,000	165 (625)	95%	10/1
PR 50-150 N	200	50	189	7,700 (2,437)	150,000	190 (719)	95%	10/1
PR 50-175 N	200	50	189	7,700 (2,437)	175,000	222 (840)	96%	10/1
PR 50-199 N	200	50	189	7,700 (2,437)	199,000	253 (958)	96%	10/1

For propane models sub N with P. Natural gas models are series 200. Propane models are series 201. All models comply with national energy efficiency regulations. Input, output and recovery may vary depending upon air inlet and exhaust outlet installations, consult manual for details.

DIMENSIONS & SHIPPING WEIGHT												
Model	Height to Top of Tank	Tank Diameter	Height to Heating System Return	Height to Cold Water Inlet	Height to Heating System Outlet	Height to T&P	Height to Gas Supply	Height to Air Inlet	Water Connections	Gas Connections	Vent Diameter	Shipping Weight
	A IN (CM)	B IN (CM)	C IN (CM)	C IN (CM)	D IN (CM)	E IN (CM)	F IN (CM)	G IN (CM)	IN NPT	IN NPT	IN	LB (KG)
NATURAL GAS												
PR 34-100 N	48 ½ (123)	22 (56)	15 ¾ (40)	15 ¾ (40)	40 ½ (103)	41 (104)	6 ¾ (16)	6 ¾ (16)	1	½	2 or 3	150 (68)
PR 34-130 N	48 ½ (123)	22 (56)	15 ¾ (40)	15 ¾ (40)	40 ½ (103)	41 (104)	6 ¾ (16)	6 ¾ (16)	1	½	2 or 3	150 (68)
PR 34-150 N	48 ½ (123)	22 (56)	15 ¾ (40)	15 ¾ (40)	40 ½ (103)	41 (104)	6 ¾ (16)	6 ¾ (16)	1	½	2 or 3	150 (68)
PR 50-130 N	62 ¾ (158)	22 (56)	15 ¾ (40)	15 ¾ (40)	54 ½ (138)	55 (140)	6 ¾ (16)	6 ¾ (16)	1	½	2 or 3	176 (80)
PR 50-150 N	63 ¾ (162)	22 (56)	15 ¾ (40)	15 ¾ (40)	55 ¾ (142)	56 ¼ (143)	6 ¾ (16)	6 ¾ (16)	1	½	2 or 3	180 (82)
PR 50-175 N	63 ¾ (162)	22 (56)	15 ¾ (40)	15 ¾ (40)	55 ¾ (142)	56 ¼ (143)	6 ¾ (16)	6 ¾ (16)	1	½	3	180 (82)
PR 50-199 N	63 ¾ (162)	22 (56)	15 ¾ (40)	15 ¾ (40)	55 ¾ (142)	56 ¼ (143)	6 ¾ (16)	6 ¾ (16)	1	½	3	180 (82)

OPTIONAL KITS	
Description	Part Number
2" Concentric vent kit	100093946
3" Concentric vent kit	100093947

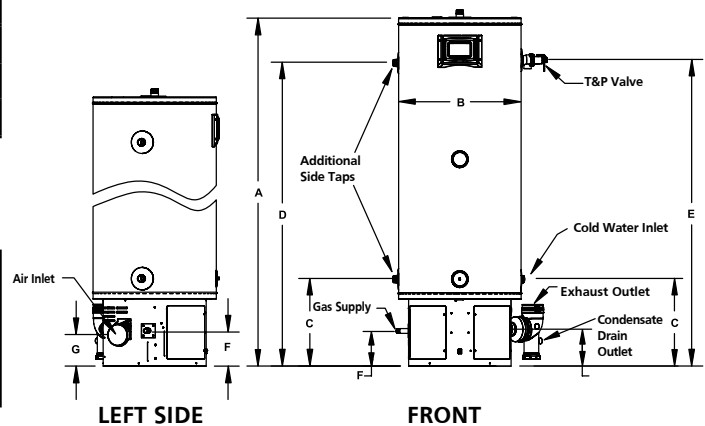
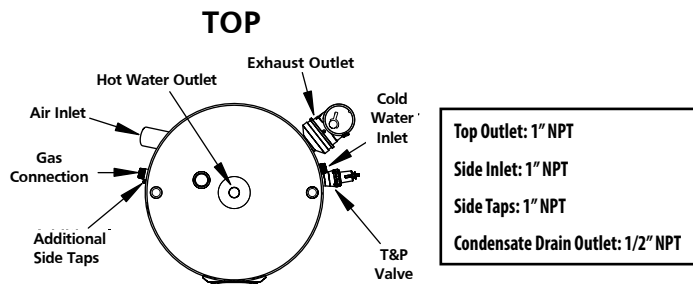

For Technical Information call 888-599-2837. A. O. Smith Enterprises Ltd. reserves the right to make product changes or improvements without prior notice.

Powered by  **TAKAGI**

The John Wood powered by Takagi condensing tankless water heaters provide endless hot water.* The durable primary heat exchanger is made of commercial-grade copper while the secondary heat exchanger is made of Type 316L stainless steel, preventing corrosion and prolonging the life of the heater. These direct vent models combine durability and versatility in an easy-to-install space-saving design.



Features of Condensing Tankless Models:

- Integrated temperature and error display
- Advanced safety features
- ULC S636 PVC, CPVC, polypropylene pipe or Cat. III/IV stainless steel venting
- Internal freeze protection system
- New 540P model with integrated recirculation pump

*When sized appropriately



Point-of-Use Electric Tankless Water Heaters

EASY TO INSTALL

- Compact size for installations with space constraints
- Wall mount vertically or horizontally
- ¾" NPT water connections (1/2" NPT reducers included)

DRY-FIRE PROTECTION

- Prevents element failure due to dry-fire
- Internal air bypass
- Temporary shutoff with excess air in chamber

SCALE-REDUCTION TECHNOLOGY

- Reduces failures and service requirements due to scale build-up
- Power-sharing technology reduces scale deposits on elements
- Dupont™ Zytel® chambers resist scale buildup

DIGITAL USER INTERFACE (2-CHAMBER MODEL)

- Easy temperature adjustment
- Error codes are clearly displayed

WARRANTY

- 6-year limited chamber warranty
- 1-year limited parts warranty



SPECIFICATIONS

Model	Series	Input		Amp Load	Recommended Breaker Size	Recommended Wire Gauge	Activation GPM	Flow Rate at 70°F Rise	Height	Depth	Width	Shipping Weight
		WATTS	VOLTS	AMP				GPM (LPM)	A IN (CM)	B IN (CM)	C IN (CM)	LB (KG)
SINGLE CHAMBER, SINGLE ELEMENT MODELS												
SSET-70E	100	7,000	240*	29	40 Amp	8	0.25	0.7 (2.6)	15 ½ (39)	6 ½ (17)	7 (18)	9 (4)
TWO CHAMBER, TWO ELEMENT MODEL												
SSET-180E	100	18,000	240	75	50 Amp x 2	8	0.25	1.8 (6.8)	16 ⅝ (42)	6 ⅞ (16)	11 ½ (29)	20 (9)

*Model is dual-rated. At 208V, wattage is 5258.

For Technical Information call 888-599-2837. A. O. Smith Enterprises Ltd. reserves the right to make product changes or improvements without prior notice.



POINT-OF-USE ELECTRIC TANKLESS COMMERCIAL/RESIDENTIAL

EASY INSTALLATION

- Compact size perfect for point-of-use applications close to fixtures
- Mounts easily to the wall
- No venting required
- ½" NPT water connection
- No T&P valve required (check local codes)

WIDE ARRAY OF MODELS AND MODES OF OPERATION

- 1.75kW – 3.5kW, 120V
- 3.5kW – 11kW, 240V (208V)
- Single Phase, 50/60 Hz
- Two mode options, easy switching
- Lavatory mode, default 105°F; temp range 80°F – 149°F
- Emergency eye wash mode, 85°F

ONBOARD SELF-DIAGNOSTICS & TROUBLESHOOTING

- Onboard self-diagnostics to monitor performance and protect the unit
- Bright LED display for status updates and making system selections and adjustments
- Error codes for troubleshooting and faster resolution

HIGHLY EFFICIENT & RELIABLE THERMOSTATIC DESIGN

- On-demand water heater capable of supplying endless hot water when appropriately sized
- Ultra-low activation of 0.17 GPM min.
- Energy efficiency 0.91 UEF or higher
- Dry-fire protection to prevent premature element failures
- Secondary temperature regulation to limit hot water output appropriate for use with hand or eye washing applications
- Scale detection (Patent Pending) and easy maintenance for extended service life of the heater

CONSTRUCTION

- Housing – Bayblend® FR3010 plastic, dark gray
- Chamber Material – Entec Nylon, glass-filled
- Sheathed copper elements for longer life

WARRANTY

- 6-Year limited warranty on chambers
- 1-Year limited warranty on all parts
- For complete information, consult the written warranty





POINT-OF-USE ELECTRIC TANKLESS COMMERCIAL/RESIDENTIAL

PRODUCT SPECIFICATIONS								
Model Number	Voltage (V)	Number of Elements	Total Input Wattage (kW)	Wattage per Element	Total Current Draw (Amps)	Recommended Canada Circuit Breaker Size (Amps)	Conductor Size (AWG)	Activation GPM
SSETU-18K	120	2	1.75	0.88	14.58	20	14	0.17
SSETU-24K	120	2	2.40	1.20	20.00	25	12	0.17
SSETU-30K	120	2	3.00	1.50	25.00	35	10	0.17
SSETU-35K	120	2	3.50	1.75	29.17	40	10	0.17
SSETU-35E	240+	2	3.50	1.75	14.58	20	14	0.17
SSETU-45E	240+	2	4.50	2.25	18.75	25	12	0.17
SSETU-55E	240+	2	5.50	2.75	22.92	30	10	0.17
SSETU-70E	240+	4	7.00	1.75	29.17	40	10	0.17
SSETU-90E	240+	4	9.00	2.25	37.50	50	8	0.17
SSETU-110E	240+	4	11.00	2.75	45.83	60	8	0.17

Copper conductors only. All wiring/conductors must be rated for 90°C or greater.

+ This model may be connected to a 208 VAC supply with reduced power output. Connection to 208 VAC may require different breaker and/or wire size than shown in the table.

NOTICE: Incoming line voltage variations may result in nuisance breaker trips. Contact Technical Support if there are multiple breaker trips when the recommended breaker size is in use.

Volts	kW	GPM AT TEMPERATURE RISE												
		25°F	30°F	35°F	40°F	45°F	50°F	55°F	60°F	65°F	70°F	75°F	80°F	85°F
120V	1.75kW	0.47	0.39	0.33	0.29	0.26	0.23	0.21	0.20	0.18	0.17	-	-	-
	2.4kW	0.64	0.54	0.46	0.40	0.36	0.32	0.29	0.27	0.25	0.23	0.21	0.20	0.19
	3kW	0.80	0.67	0.57	0.50	0.45	0.40	0.36	0.33	0.31	0.29	0.27	0.25	0.24
	3.5kW	0.94	0.78	0.67	0.59	0.52	0.47	0.43	0.39	0.36	0.33	0.31	0.29	0.28
240V (208V)	3.5kW	0.94	0.78	0.67	0.59	0.52	0.47	0.43	0.39	0.36	0.33	0.31	0.29	0.28
	4.5kW	1.20	1.00	0.86	0.75	0.67	0.60	0.55	0.50	0.46	0.43	0.40	0.38	0.35
	5.5kW	1.47	1.23	1.05	0.92	0.82	0.74	0.67	0.61	0.57	0.53	0.49	0.46	0.43
	7kW	1.87	1.56	1.34	1.17	1.04	0.94	0.85	0.78	0.72	0.67	0.62	0.59	0.55
	9kW	2.41	2.01	1.72	1.50	1.34	1.20	1.09	1.00	0.93	0.86	0.80	0.75	0.71
	11kW	2.94	2.45	2.10	1.84	1.63	1.47	1.34	1.23	1.13	1.05	0.98	0.92	0.87

Cold water inlet temperatures raised to 105°F setpoint.



POINT-OF-USE ELECTRIC TANKLESS COMMERCIAL/RESIDENTIAL

DIMENSIONS

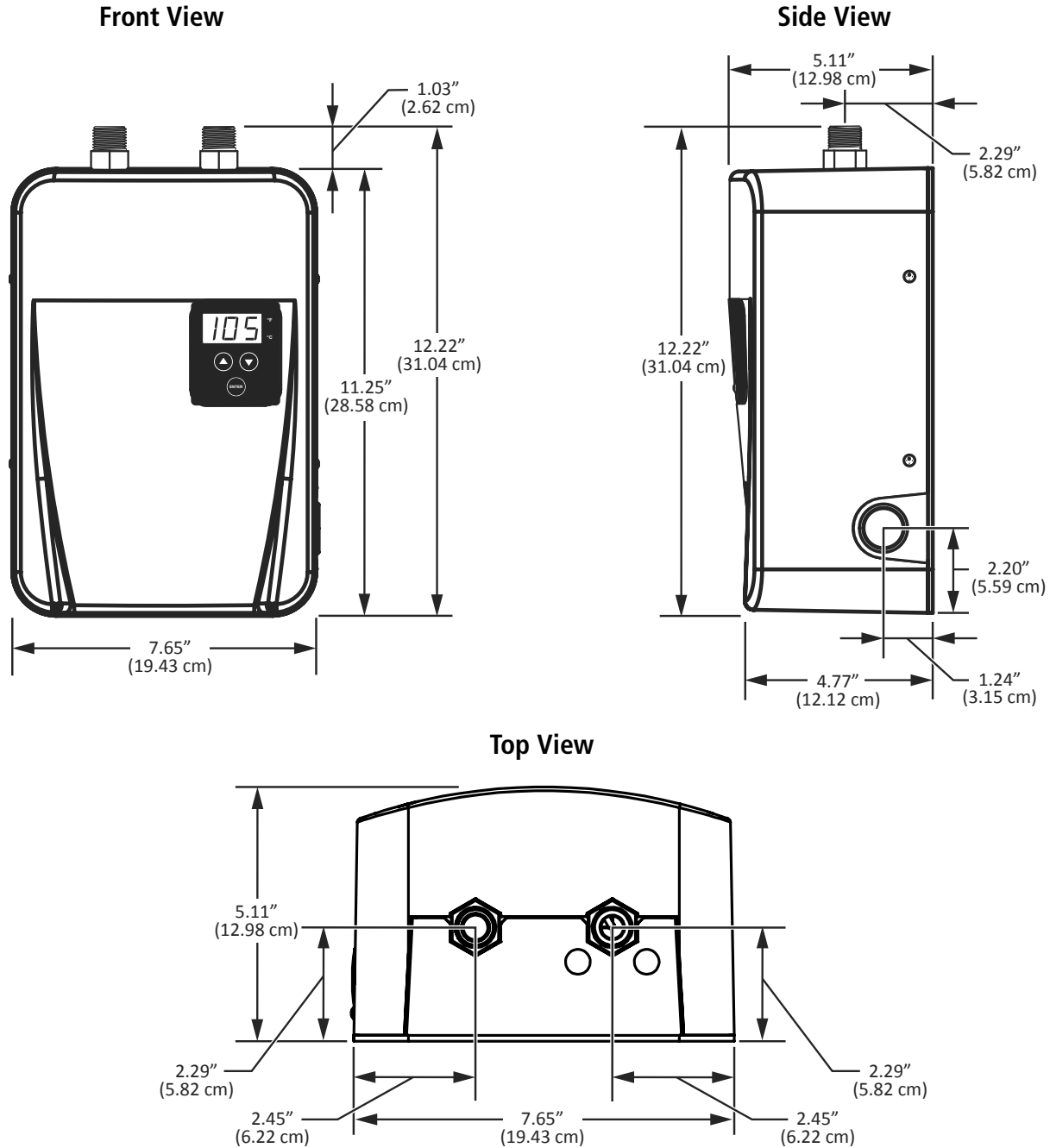

DIMENSIONS – SHIPPING

Models	Width in (cm)	Height in (cm)	Depth in (cm)	Weight lb (kg)
1.75kW - 5.5kW	11.25 (28)	15.5 (38)	8 (20)	6.0 (2.7)
7.0kW - 11kW	11.25 (28)	15.5 (38)	8 (20)	8.0 (3.6)



POINT-OF-USE ELECTRIC TANKLESS COMMERCIAL/RESIDENTIAL

INSTALLATION

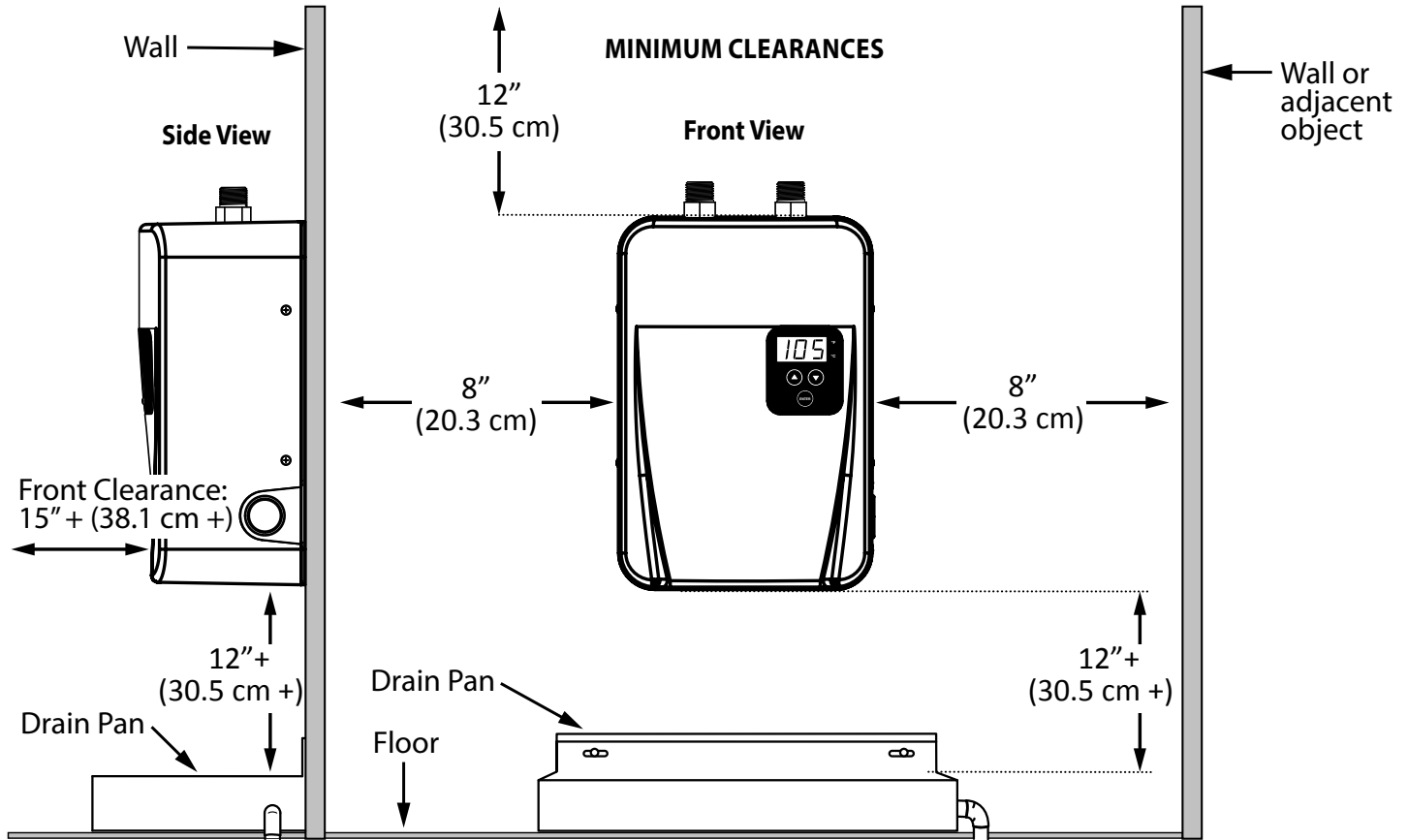

ORIENTATION & CLEARANCE

- All models must be oriented with the inlet and outlet facing upward.
- Top clearance – a minimum of 12 inches (30.5 cm) to provide access for plumbing connections.
- Side clearance – a minimum of 8 inches (20.3 cm) to remove the screws and protective cover and to provide access for electrical wires to enter through the side of the unit.
- Bottom clearance – a minimum of 12 inches (30.5 cm) for access to and maintenance of heating elements. Do not store any items beneath the water heater.
- Front clearance – a minimum of 8 inches (20.3 cm). In the absence of a door or removable access panel in front of the heater, allow a minimum of 15 inches (38.1 cm) for cover removal and ease of service.

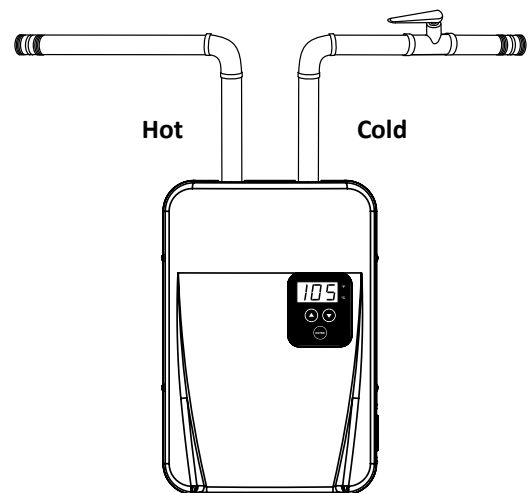

For Technical Information call 1-888-599-2837. A. O. Smith Enterprises Ltd. reserves the right to make product changes or improvements without prior notice.

ADAPT™ PREMIUM CONDENSING TANKLESS WITH X3™ SCALE PREVENTION TECHNOLOGY & INTEGRATED RECIRC PUMP

Introducing A. O. Smith's ADAPT™ premium condensing gas tankless water heaters, delivering robust, on-demand performance and the flexibility to install in practically any residential setting.

FEATURES:

X3™ SCALE PREVENTION TECHNOLOGY (PATENTED DESIGN)

- Units maintain like-new performance longer and life extended by up to 3x versus unprotected units
- Eliminates need for annual descaling
- Included with all X3 models, optional accessory for M (bypass) models

HEAVY-DUTY STAINLESS STEEL HEAT EXCHANGER DESIGN

- Single heavy-duty stainless steel heat exchanger design minimizes internal welds and improves overall reliability
- More resilient to scale buildup and corrosion

INTEGRATED RECIRCULATION PUMP & DISPLAY

- Integrated recirculation pump
- Built-in Control Display to set and review recirc schedules, status, and error codes

PERFORMANCE & EFFICIENCY

- 160,000, 180,000, 199,000 BTU/h models
- 9,000 BTU/h min. input
- 22:1 turndown ratio on 199,000 BTU/h models
- 10.5 GPM maximum flow rate
- 0.4 GPM activation flow rate
- 0.95 UEF, ENERGY STAR® certified
- Ultra Low NOx: NOx emissions less than 14 ng/J or 20 ppm for natural gas and less than 77 ppm for propane

ULTIMATE FLEXIBILITY EASE OF INSTALLATION

- Field convertible from natural gas to LP (kit included with unit)
- Vent up to 75' (23 m) with 2" pipe or up to 150' (46 m) with 3" pipe
- Cat. IV venting may be used
- Vent with ULC S636 certified PVC, CPVC, or polypropylene pipe
- X3 models include pressure relief valve
- Outdoor rated power cord standard on every unit
- Cascade up to 12 units (cable included with unit)

LIMITED WARRANTY

- No hard water exclusions on X3 models (exclusions apply to M models even with the addition of the optional X3 cartridge)
- 15-year limited warranty on heat exchanger in residential applications
- 5-year limited warranty on all parts in residential applications
- 1-year limited warranty on heat exchanger and parts in commercial applications



ATHR-160X3, ATHR-180X3, ATHR-199X3
X3 Scale Prevention Technology included



ATHR-160M, ATHR-180M, ATHR-199M
X3 Scale Prevention Technology can be added at any time (optional accessory)



CSA/ANSI Z21.10.3 • CSA 4.3



Gas Tankless Water Heaters

RESIDENTIAL/COMMERCIAL MODELS

		ATHR-160M	ATHR-160X3	ATHR-180M	ATHR-180X3	ATHR-199M	ATHR-199X3
Installation Type		Indoor / Outdoor*		Indoor / Outdoor*		Indoor / Outdoor*	
X3™ Scale Prevention Technology		Optional Accessory	Included	Optional Accessory	Included	Optional Accessory	Integrated
Recirculation Pump		Integrated					
Input Rate	Minimum	9,000 BTU/h					
	Maximum	160,000 BTU/h		180,000 BTU/h		199,000 BTU/h	
Fuel Type		Natural Gas (Field Convertible to Liquid Propane, Kit Included)					
Heat Exchanger		Stainless Steel					
Uniform Energy Factor (UEF)		0.95					
Maximum Flow Rate**		10.5 GPM					
Activation Flow Rate		0.4 GPM					
Continuous Fire Flow Rate		0.26 GPM					
Water Pressure Min. - Max.		15 - 150 PSI (40 PSI Recommended for Maximum Flow)					
Supply Gas Pressure (NG)	Min. in W.C. (kPa)	3.5 (0.9)					
	Max. in W.C. (kPa)	10.5 (2.6)					
Supply Gas Pressure (LP)	Min. in W.C. (kPa)	8.0 (2)					
	Max. in W.C. (kPa)	13.0 (3.2)					
Hot/Cold Connections		3/4" NPT					
Gas Connection		1/2" NPT					
Temperature Settings Min. - Max.		100°F (38°C) - 140°F (60°C); Default 120°F (49°C)					
Ignition System		Electronic Ignition					
Power Supply		120V, 50Hz/60Hz, <5A					
Sound Level		50.3 dB**					
Elevation		Certified from Sea Level to 10,100' (3,078.5 m)					
Freeze Protection*		- 5°F (-21°C)					
Venting - Exhaust, Intake	Type	Power Direct Vent					
	Size, Max Run	2", 75' (5 cm, 22.9 m); 3", 150' (8 cm, 45.7 m)					
	Material	ULC S636 certified PVC, CPVC, or polypropylene					
Unit Dimensions	Height***	33.8" (86 cm)	41.8" (106.2 cm)	33.8" (86 cm)	41.8" (106.2 cm)	33.8" (86 cm)	41.8" (106.2 cm)
	Width	16.5" (42 cm)					
	Depth	16.1" (41 cm)					
	Weight	104 lb. (47 kg)					
Shipping Dimensions****	Height	20.8" (53 cm)					
	Width	22.3" (57 cm)					
	Depth	40" (102 cm)					
	Weight	125 lb (57 kg)					

All models are ENERGY STAR® certified.

* Outdoor installations require outdoor vent cap kit (100369060) sold separately.

** Based on factory settings.

*** Height from flue collar to top of X3 scale control media cartridge on X3 models and to top of manifold cartridge on M models.

**** Packaged and shipped on unit back.

*Internal freeze protection for heater only; Freeze protection for the X3 and bypass cartridges (kits sold separately) is recommended for outdoor installations.

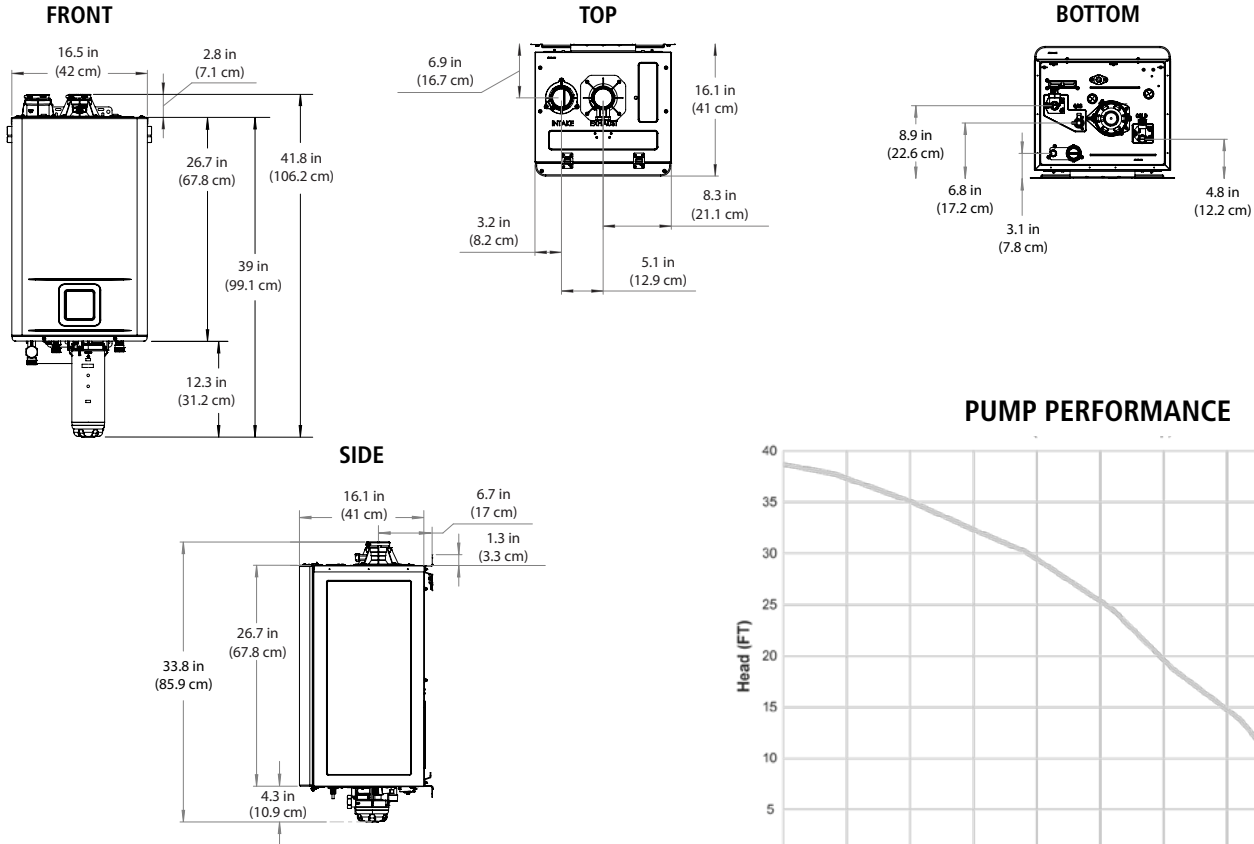

PUMP PERFORMANCE

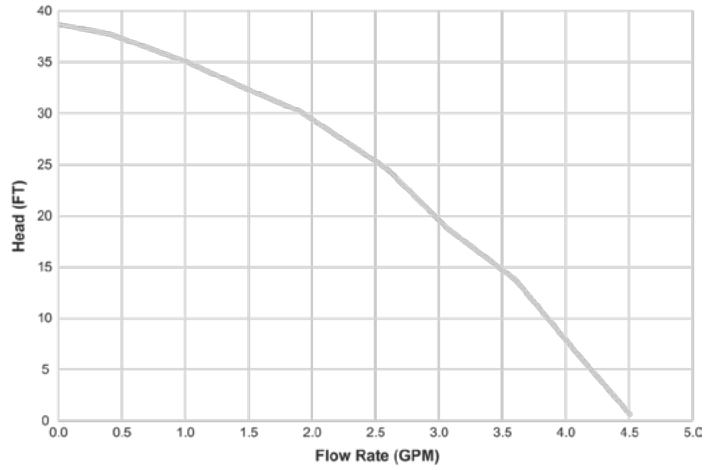



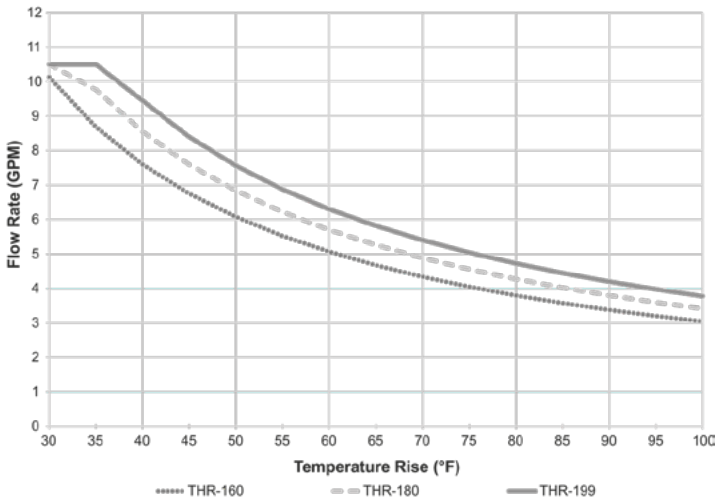



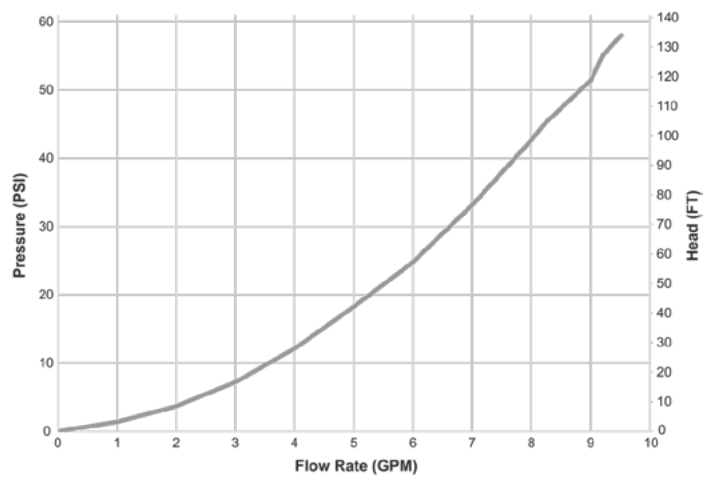

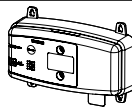
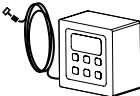
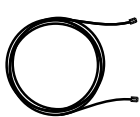
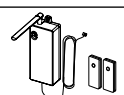
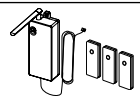
FLOW RATE

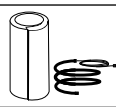

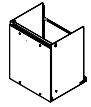
PRESSURE LOSS

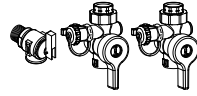

Item	Material Number		Description
X3 Cartridge	100368986		Add to an M model heater to prevent scale buildup and eliminate the need for annual descaling.
Wi-Fi Module Kit	100371922		Wi-Fi Module for electronically connecting tankless water heaters to the internet and adapter to connect to the water heater. Kit contains: Module (1x), Cable (1x), Adapter (1x)
Remote Temperature Controller	100377310		Remote Temperature Controller with 10' (3 m) cable.
Communication Cable - 10' (3 m)	100377341		Replacement 10' (3 m) Communication Cable for Remote Temperature Controller, WiFi Module, or On-Demand Receiver.
Communication Cable - 32' (10 m)	100377342		Extended 32' (10 m) Communication Cable for Remote Temperature Controller, WiFi Module, or On-Demand Receiver.
Remote Recirculation Kit - Two Buttons	100371920		Remote Recirculation Kit activates the water heater and recirculation at a touch of a button for on-demand hot water. Kit contains: Receiver (1x), Buttons (x2)
Remote Recirculation Kit - Three Buttons	100371921		Remote Recirculation Kit activates the water heater and recirculation at a touch of a button for on-demand hot water. Kit contains: Receiver (1x), Buttons (x3)
Individual Spare Button	100377309		Add Remote Recirculation Buttons to a system to a maximum of 30.
X3 Freeze Protection (X3 Models)	100325654		Freeze Protection for the X3 cartridge for outdoor installations. Cartridge is not protected by the water heater's internal freeze protection.
Bypass Freeze Protection (M Models)	100371918		Freeze Protection for the bypass cartridge for outdoor installations. Cartridge is not protected by the water heater's internal freeze protection.
Pipe Cover	100374697		Pipe Cover protects plumbing connections to the heater while improving the appearance of the installation. Affixes to bottom of heater.
Neutralizer Assembly Kit	100112159		Neutralizer Assembly neutralizes the condensate (acidic water) that forms in the heat exchanger of the water heater. It connects to the condensate drain port of the water heater by using connectors included with the neutralizer kit.
Outdoor Vent Cap Kit	100369060		Vent cap kit and accessories for installing the tankless heater outdoors. Kit contains: Vent Cap (1x), User Interface Overlay (1x)
Isolation Valve Kit with Pressure Relief Valve	100112156		Isolation Valves help control water flow during routine maintenance. Pressure Relief Valve limits pressure in the water heater. X3 models include a pressure relief valve.
Cross Over Valve Kit	100327167		For systems without a dedicated return line necessary. Install at the faucet furthest from the hot water heater.

Tankless High Efficiency Condensing Models

Features

Designed for Performance

- Condensing technology provides up to a 0.94 UEF
- Primary heat exchanger is constructed of commercial-grade copper which is more resilient against erosion
- Secondary heat exchanger is made of Type 316L Stainless Steel to protect against corrosion
- Continuous maximum flow rates up to 10.0 GPM
- Available in natural gas (NG) or propane (LP)
- JWT 540H can be used in both residential and commercial applications
- Electronic ignition - no pilot light
- Includes a built-in temperature controller and advanced diagnostics for easy troubleshooting
- Factory-installed power cord
- New 540P model with integrated recirculation pump
- Easy-Link up to 4 units with no additional parts or accessories needed using built-in Easy-Link System (540 models only)
- Multi-link up to 20 units (540 models only) with a multi-unit controller (TM-MC02)
- Internal freeze protection system

Safety features

- Air-Fuel Ratio (AFR) sensor
- Exhaust & water temperature safety control
- Overheat cut-off fuse

Power direct vent design

- Exhaust, 3" venting up to 70 equivalent feet or 4" venting up to 100 equivalent feet
- Provides flexible venting with ULC S636 approved PVC, CPVC or polypropylene pipe for intake and exhaust (solid core only) or Category III/IV Stainless Steel



JWT-240H

JWT-340H

JWT-540H



JWT-540P



540H model only

ANSI Z21.10.3 CSA 4.3

WARRANTY

15-year limited warranty on heat exchanger in residential applications

6-year limited warranty on heat exchanger in commercial applications

5-year limited warranty on all parts

Consult installation manual for terms and conditions or visit www.johnwoodwaterheaters.com for more information.

FLOW RATE vs TEMPERATURE RISE

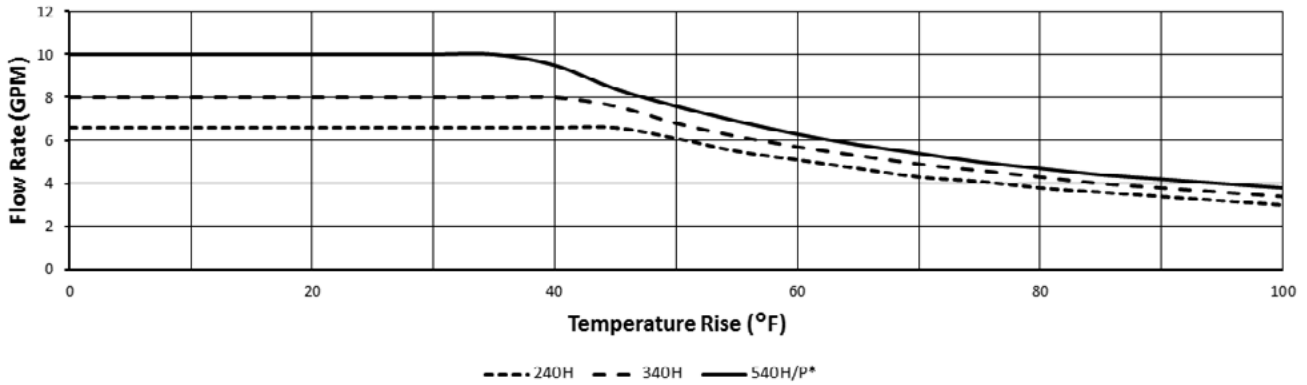

*Maximum flow rate with set temperature above 130°F (55°C) is 8.0 GPM.

PRESSURE LOSS vs FLOW RATE

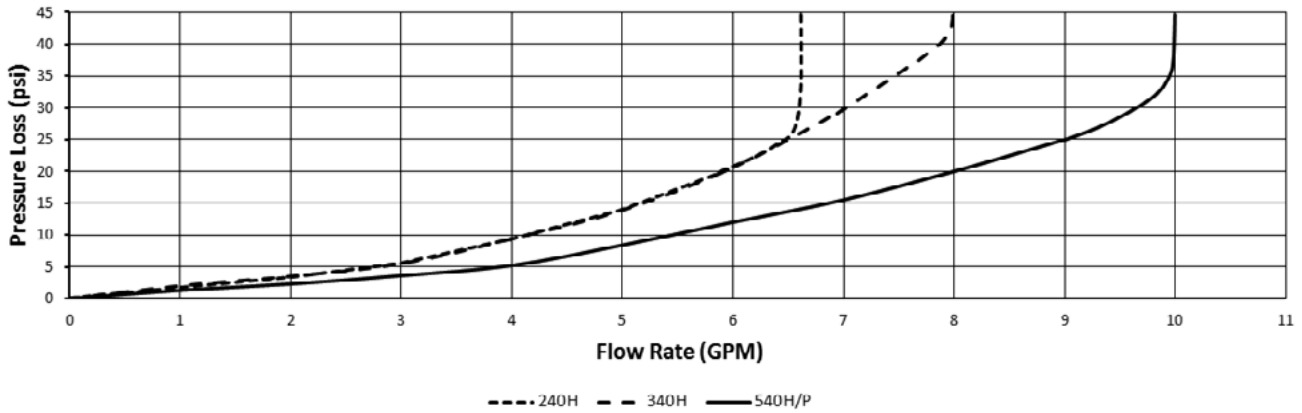

Optional Accessories

PART NUMBER	DESCRIPTION
100112163	Concentric termination kit
100112159	Condensate neutralizer kit
100209924	Remote temperature controller for temperatures up to 167°F
100112572	Remote temperature controller for temperatures up to 185°F (540H models only)
100112691	Multi-unit controller (540H/P models only)
100112156	Isolation valve kit (with Pressure Relief Valve)
100112190	Pipe cover
100113154	Product Preservers [®] Anti-Scale System
100113130	Non-return valve for Common Vent Systems

SAMPLE SPECIFICATION

Water heater(s) shall be John Wood tankless water heater model _____, having a maximum input rating of _____ BTU/h. The heater shall have ¾" male NPT water and gas connections. The inlet gas supply pressures shall be _____ in. WC (minimum) up to _____ in. WC (maximum) for _____ fuel. The heater(s) shall incorporate an integrated temperature controller that will provide heater set temperature, diagnostic, and fault history information.

The water heater(s) shall be vented with 3" or 4" ULc S636 approved Schedule 40 PVC or CPVC, polypropylene, or Category IV vent pipe with a length not to exceed 70' (equivalent) for 3" vent or 100' (equivalent) for 4" vent, terminating horizontally or vertically. The intake air pipe may be of such material as PVC or CPVC, ABS, polypropylene, aluminum, or Category IV pipe and cannot exceed 70' (equivalent) for 3" pipe or 100' for 4" pipe.

The water heater(s) shall use a commercial grade copper alloy, fin tube primary heat exchanger with quick release brass or bronze waterways, and a 316L stainless steel secondary heat exchanger. The heater(s) shall be controlled by an onboard solid-state printed circuit board using thermistors to monitor inlet and outlet water temperature and exhaust temperature, a flow sensor to measure flow rate, a flame sensor to monitor combustion, and an air-fuel ratio rod to measure and adjust operation in order to maintain optimal combustion efficiency. The heater(s) shall also consist of inline fusing and surge absorbers for electrical surge protection, an electronic spark igniter, aluminized stainless steel burners, hi-limit temperature switch to monitor water temperature, modulating gas valve, and an overheat cutoff fuse. The heater(s) shall include an exhaust temperature monitoring system using an exhaust thermistor and automatic hi-limit switch to maintain safe exhaust temperatures for Schedule 40 PVC and incorporate ceramic heating blocks and an auto-fire system for freeze protection of the heat exchanger and water piping.

The water heater(s) shall be design certified by CSA according to ANSI Z21.10.3 - CSA 4.3 and meet the energy efficiency requirements of NRCan and the current edition of ASHRAE 90.1.

SPECIFICATIONS

Model	Fuel Type	Gas Consumption Input		Inlet Gas Pressure		Energy Factor	Max GPM*	Hot and Cold Gas Connection	Dimensions IN (CM)			Unit Weight LB (KG)
		Min. BTU/h	Max. BTU/h	Min. W.C.	Max. W.C.				Height A	Width B	Depth C	
JWT-240H-N	Natural	15,000	160,000	5.0	10.5	0.94	6.6	¾" NPT	22 ½ (57)	17 ¾ (45)	10 ¾ (27)	58 (26)
JWT-240H-P	Propane	13,000	160,000	8.0	14.0	0.94	6.6	¾" NPT	22 ½ (57)	17 ¾ (45)	10 ¾ (27)	58 (26)
JWT-340H-N	Natural	15,000	180,000	5.0	10.5	0.94	8.0	¾" NPT	22 ½ (57)	17 ¾ (45)	10 ¾ (27)	58 (26)
JWT-340H-P	Propane	13,000	180,000	8.0	14.0	0.94	8.0	¾" NPT	22 ½ (57)	17 ¾ (45)	10 ¾ (27)	58 (26)
JWT-540H-N	Natural	15,000	199,000	5.0	10.5	0.93	10.0	¾" NPT	22 ½ (57)	17 ¾ (45)	10 ¾ (27)	59 (27)
JWT-540H-P	Propane	13,000	199,000	8.0	14.0	0.93	10.0	¾" NPT	22 ½ (57)	17 ¾ (45)	10 ¾ (27)	59 (27)
JWT-540P-N	Natural	15,000	199,000	4.0	10.5	0.93	10.0	¾" NPT	23 ⅝ (60)	17 ¾ (45)	11 ¼ (29)	61 (28)
JWT-540P-P	Propane	13,000	199,000	8.0	14.0	0.93	10.0	¾" NPT	23 ⅝ (60)	17 ¾ (45)	11 ¼ (29)	61 (28)

15-150 psi Water Pressure. 40 psi or above is recommended for maximum flow.

*Current numbers based on factory testing; 0.4 GPM required for continuous fire after initial ignition.

Models are certified from sea level to 10,100 ft. (3,078 m) elevations.

The manufacturer reserves the right to discontinue, or change at any time, specifications or designs without notice and without incurring obligation.

JWT-240H, JWT-340H and JWT-540 H/P DIMENSIONS MINIMUM CLEARANCES: TOP 12", BOTTOM 12", FRONT* 4", BACK 1", SIDES 3" *Recommended 24" clearance from front of unit for maintenance

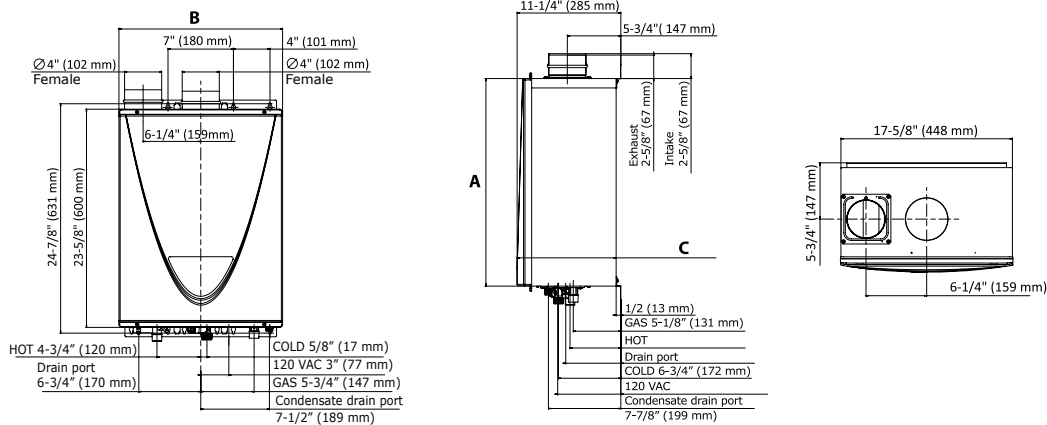

Bottom View 240H, 340H, and 540H

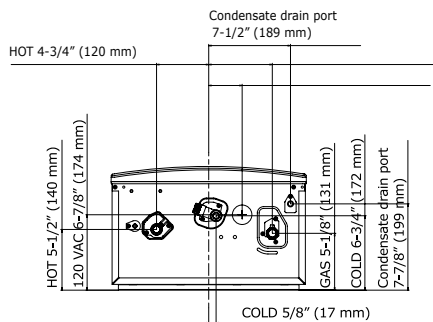

Bottom View 540P

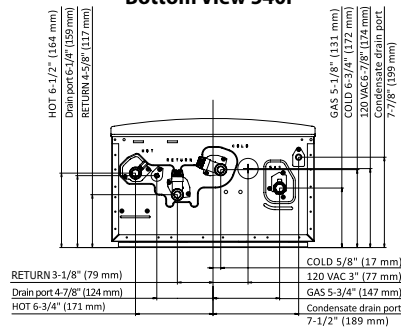

John Wood Storage Booster Tanks provide the hot water storage capacity that is required to support high-demand applications including combination hot water and space heating applications.

Features

- Available in 40, 50, and 80 gallon capacities to meet the hot water requirements of modern households
- Meets and exceeds NRCan energy efficiency standards
- Glass-lined inner tanks for long life
- Automatic temperature control through adjustable thermostat



Low Lead Content

WARRANTY

5 Year Limited Tank Warranty*

1 Year Limited Parts Warranty

Consult installation manual for terms and conditions or visit www.johnwoodwaterheaters.com for more information.

*1 Year Limited Tank Warranty on Commercial Installations

DIMENSIONS & SHIPPING WEIGHT

Model	Capacity	Water Connections	Height to Top of Tank	Tank Diameter	Height to T&P	Approximate Shipping Weight
	USG (L)	IN	IN (CM)	IN (CM)	IN (CM)	LB (KG)
JWSB-40C	40 (151)	3/4" NPT	50 (127)	20½ (52)	41 (104)	98 (45)
JWSB-50C	50 (189)	3/4" NPT	49 (124)	23 (58)	40½ (103)	142 (65)
JWSB-80C	80 (287)	3/4" NPT	60½ (154)	24 (61)	52 (132)	174 (79)

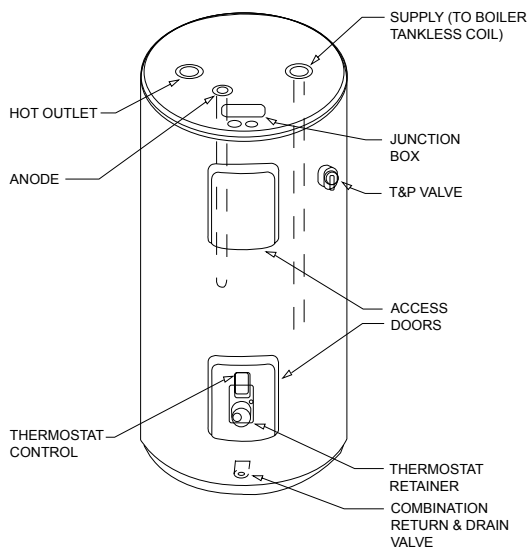

PREFERRED INSTALLATION

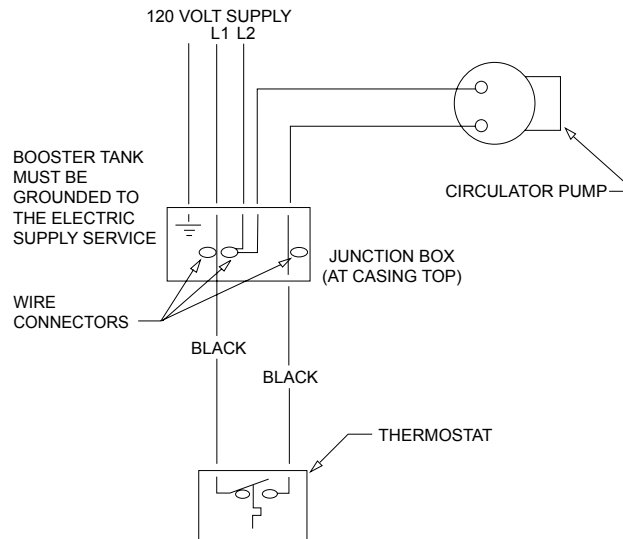
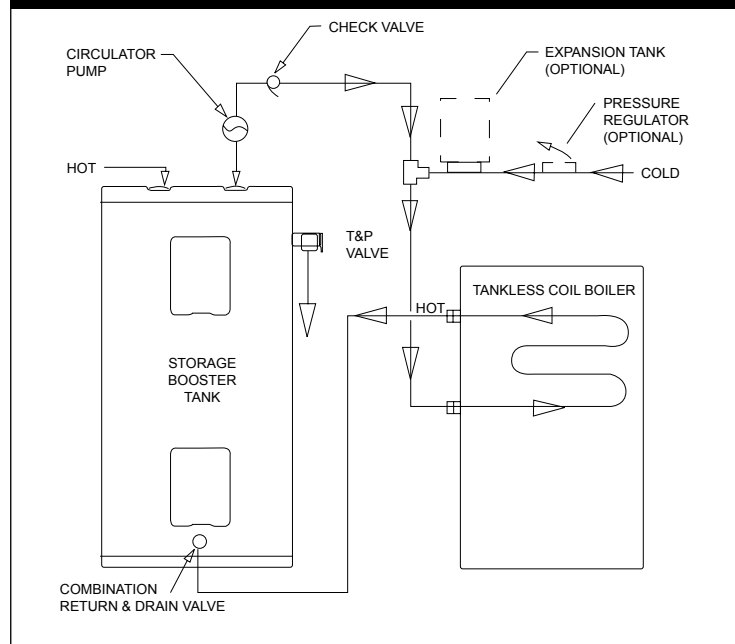

IF WIRE HAS TO BE REPLACED IN THE FIELD, USE ONLY TYPE TEW 105°C WIRE

FlowTHRU® Series Storage Tanks

The line of Flow THRU® hot water storage tanks are available in 19 and 30 US gallon models. The units were specifically designed to complement our tankless series of water heaters enhancing their performance to meet the needs of our customers.

FEATURES

- Exclusive, patented TankSaver® design works to prolong tank life
- Factory installed dielectric nipples for ease of installation
- T&P valve conveniently located on the side
- Front access junction box for convenient electrical hook-up
- Equipped with an adjustable thermostat, pre-wired and ready for connection to a circulator pump

WARRANTY*

- 6 year limited tank warranty
- 1 year limited parts warranty

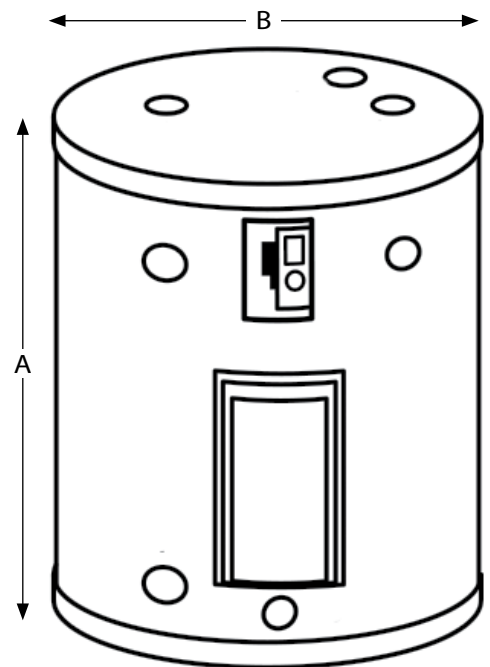

SPECIFICATIONS							
Model	Series	Capacity		Height	Diameter	Water Connections	Shipping Weight
		USG	L	A IN (CM)	B IN (CM)	IN NPT	LB (KG)
GST 20	200	19	67	25 ½ (65)	19 (48)	¾	65 (29)
GST 30	200	30	108	31 ½ (80)	22 (56)	¾	94 (43)

*In residential applications. Reduced warranty in commercial applications.

Reference Calculations and Conversions for Electricity

Ohm's Law

Ohm's Law defines the relationships between (P) power, (E) voltage, (I) current, and (R) resistance. One ohm is the resistance value through which one volt will maintain a current of one ampere.

(I) Current is what flows on a wire or conductor like water flowing down a river. Current flows from points of high voltage to points of low voltage on the surface of a conductor. Current is measured in (A) amperes or amps.

(E) Voltage is the difference in electrical potential between two points in a circuit. It's the push or pressure behind current flow through a circuit, and is measured in (V) volts.

(R) Resistance determines how much current will flow through a component. Resistors are used to control voltage and current levels. A very high resistance allows a small amount of current to flow. A very low resistance allows a large amount of current to flow. Resistance is measured in ohms.

(P) Power is the amount of current times the voltage level at a given point measured in wattage or watts.

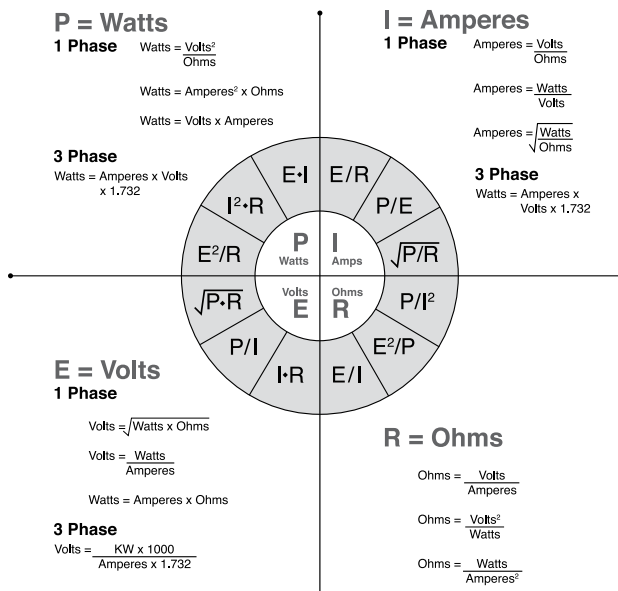

Reference Guide for Water Heating

One US gallon of fresh water weighs 8.333 lb.

Water expands 4.34% heated from 40° to 212° F.

1 BTU = Amount of heat required to raise the temperature of 1 lb. of water 1° F.

$$\text{Recovery GPH (Electric)} = \frac{KW \times 3412}{8.33 \times \Delta T}$$

$$\text{Recovery GPH (Gas)} = \frac{\text{Input} \times \text{Efficiency}}{8.33 \times \Delta T}$$

$$\text{Req. BTU Input} = \frac{\text{Water Heater Capacity} \times 8.33 \times \Delta T}{\% \text{ Efficiency}}$$

First Hour Draw (FHD)

$$FHD = (\text{Storage} \times \% \text{ Efficiency}) + \text{Recovery}$$

% of hot and cold water needed to be mixed to obtain a desired temperature

$$\text{Hot water percentage} = \frac{M-C}{H-C}$$

$$\text{Cold water percentage} = \frac{H-M}{H-C}$$

Water C = Cold Water Temperature
 H = Hot Water Temperature
 M = Mixed Water Temperature

$$\% \text{ Efficiency} = \frac{GPH \times 8.33 \times \text{Temp. Rise}}{BTU/Hr. \text{ Input}}$$

Reference Guide for Water Heating

$$\text{BTU/Output} = \text{GPH} \times 8.33 \text{ lbs./Gal.} \times \text{Temp. Rise}$$

$$\text{BTU/Input} = \frac{\text{GPH} \times 8.33 \times \text{Temp. Rise}}{\% \text{ Efficiency}}$$

$$\text{KW} = \frac{\text{GPH} \times 8.33 \times \text{Temp. Rise}}{3413}$$

Temperatures

To convert from degrees Centigrade (C) to degrees Fahrenheit (F) multiply the number of degrees C by 9/5 (or 1.8) and add 32.

To convert from degrees Fahrenheit (F) to degrees Centigrade (C) first subtract 32 from the number of degrees F then multiply the remainder by 5/9 (or 0.556).

Gas

Gas	BTU
1 lb. of Butane	= 21,300
1 Gal. of Butane	= 102,600
1 Cu. Ft. of Butane	= 3,260
1 Cu. Ft. of Manufactured	= 530
1 Cu. Ft. of Mixed	= 850
1 Cu. Ft. of Natural	= 1,075
1 lb. of Propane	= 21,600
1 Gal. of Propane	= 91,700
1 Cu. Ft. of Propane	= 2,570

Oil vs. Electric vs. Propane vs. Natural Gas

Oil	1 litre = 36,515 BTUs* Example Price = 60.0¢/litre
Electric	1 Kilowatt Hour = 3,413 BTUs* Example Price = 10.1¢/KW (kilowatt)
Propane	1 litre = 24,197 BTUs* Example Price = 63.0¢/litre
Natural Gas	1 M ³ 35,310 BTUs* Example Price = 44.0¢/M ³ (cubic metre)**
Formula	$\frac{\text{BTUs per Unit} \times \text{Efficiency}}{\text{Cost per Unit}}$
Example:	Propane = $\frac{24,197 \times 92\%}{0.63} = 35335 \text{ BTUs per } \1.00

GST is extra on all prices.

* Information supplied by The Ontario Ministry of Energy.
** This price reflects delivery charge and monthly administration charge to service your account.

Formulas and Facts

- 1 gallon of water weighs 8.33 lbs.
- 1 gallon of water has a volume of 231 cubic inches
- 1 cubic foot of water weighs 62.38 lbs. and contains 7.48 gallons of water
- 100 feet of 3/4" copper pipe contains 2.5 gallons of water; 1" pipe contains 4.3 gallons
- 8.33 BTU will raise 1 gallon of water 1° F at 100% efficiency (electricity)

Reference Guide for Water Heating

- 11 BTUs are required to raise 1 gallon of water 1° F at 70% efficiency (gas)
- 3,412 BTUs equal 1 kilowatt hour (KW)
- 1 KW will raise 410 gallons of water 1° F at 100% efficiency
- 1 BTU x 0.293 = watts
- 1 KW = 1000 watts
- 2.42 watts are required to raise 1 gallon of water 1° F
 - 1 KW will raise 10.25 gallons of water 40° F at 100% efficiency
 - 1 KW will raise 6.8 gallons of water 60° F at 100% efficiency
 - 1 KW will raise 5.1 gallons of water 80° F at 100% efficiency
 - 1 KW will raise 4.1 gallons of water 100° F at 100% efficiency

Formula for mixing hot water

$$\frac{M-C}{H-C} = \text{Percent of hot water required to produce desired mixed temperature}$$

Where:

M = mixed water temperature;
 C = cold water temperature;
 H = hot water temperature

For example: How much of a shower is hot water and how much is cold water?

My shower temperature is 105° F, my water heater thermostat is set on 120° F and the cold water inlet temperature is 50° F.

$$\frac{105 - 50}{120 - 50} = \frac{55}{70} = 79\% \text{ of the shower is } 120^\circ \text{ hot water}$$

This formula for mixing hot water is important when explaining a NOT ENOUGH HOT WATER trouble call and the water heater is functioning properly.

ELECTRIC	GAS
ENERGY COSTS:	ENERGY COSTS:
KW x fuel costs = energy costs	Cubic feet x fuel costs = energy costs
100 x 0.05 = \$5.00	100 x 0.75 = \$7.50
To obtain gallons per hour (GPH) recovery <u>WATTS</u> 2.42 x (temp rise ° F)	To obtain gallons per hour (GPH) recovery <u>HOURLY INPUT (BTUs)</u> 11.0 x (temp rise ° F)
I have a 30-gallon electric heater, non-simultaneous operation, 4,500 watt elements. What is the recovery GPH if my cold water is 40° F and my thermostat is set to 120° F? <u>4,500</u> 2.42 x 80 per hour = 23 gallons	I have a 30-gallon gas heater, rated at 40,000 BTUs. What is the recovery GPH if my cold water is 40° F and my thermostat is set to 120° F? <u>40,000</u> 11.0 x 80 per hour = 45 gallons
Temperature Rise (° F) <u>WATTS</u> 2.42 x GPH	Temperature Rise (° F) <u>HOURLY INPUT (BTUs)</u> 11.0 x GPH
I have a 30-gallon electric heater, non-simultaneous operation, 4,500 watt elements. What is the maximum temperature rise if the heater can recover 23 gallons per hour? <u>4,500</u> 2.42 x 23 rise = 80° temp	I have a 30-gallon gas heater, rated at 40,000 BTUs. What is the maximum temperature rise if the heater can recover 45 gallons per hour? <u>40,000</u> 11.0 x 45 rise = 80° temp

Reference Guide for Water Heating

Oil	BTU
1 Gal. #1 Fuel	= 136,000
1 Gal. #2 Fuel	= 138,500
1 Gal. #3 Fuel	= 141,000
1 Gal. #5 Fuel	= 148,500
1 Gal. #6 Fuel	= 152,000

1 lb. of Gas = 28" Water Column
 1 lb. of Gas = 16 oz.
 100 Cu. Ft. = 1 therm.

Conversions

Multiply	By	To Obtain
BTU/HR	0.293	W
Ft.	0.3048	m
Ft./min., fpm	0.00508	m/s
Ft. ²	0.0929	m ²
Ft. ³	0.0283	m ³
Gallon (U.S. 231 in ³)	3.79	L
Gallon	0.00379	m ³
Horsepower (boiler)	9.81	KW
Inch	25.4	mm
Mile	1.61	km
Pound lb. (mass)	0.454	kg
Psi	6.89	kPa