



Giant®

Enhancing everyday living

RESIDENTIAL ELECTRIC WATER HEATERS

POINT-OF-USE

| 2 | 5 | 10 | 16 | 22 | IMP. GALLONS

BENEFITS

1 - HIGH DENSITY FIBERGLASS INSULATION

Provides superior heat retention and efficiency while being environmentally friendly.

2 - FACTORY INSTALLED 3/4" NPT DI-ELECTRIC NIPPLES

Extend the life of the water heater by providing excellent corrosion protection.

3 - HIGH QUALITY MAGNESIUM ANODE

Provides excellent protection against the corrosive effects of water and extends tank life.

4 - ELECTRIC ELEMENTS

All models are equipped with CSA approved screw-in type immersion elements made by Giant. These elements can be easily replaced with no special tools, resulting in low maintenance costs.

5 - GLASS-LINED INNER TANK

A uniquely formulated blue cobalt glass enriched with zircon is fused to specially treated steel at 1,600°F (871°C) to provide the best coating available against corrosion for many years. The tank is certified at a test pressure of 300 PSI (2,068 kPa) and a working pressure of 150 PSI (1,035 kPa).

6 - AUTOMATIC TEMPERATURE CONTROL

Adjustable thermostat will provide years of reliable trouble-free service at the desired water temperature and a safety cut-off is provided for abnormal conditions.

7 - FACTORY INSTALLED TEMPERATURE AND PRESSURE-RELIEF VALVE†

Protects the tank from the damaging effects of excessive temperature and pressure.

†Supplied but not installed for 130E model.



103ETE Model

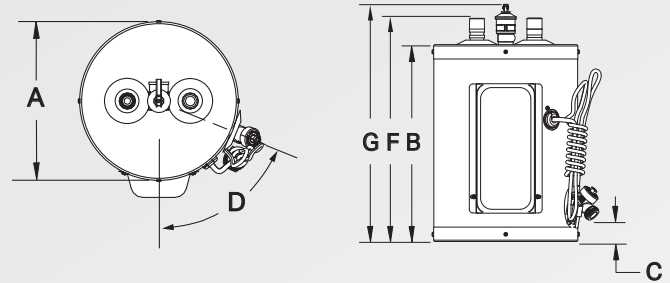

106SEO, 112SEO & 119SEO1 Models

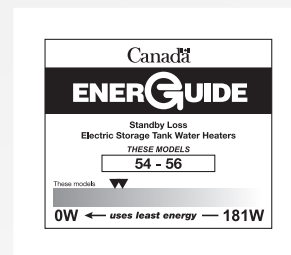
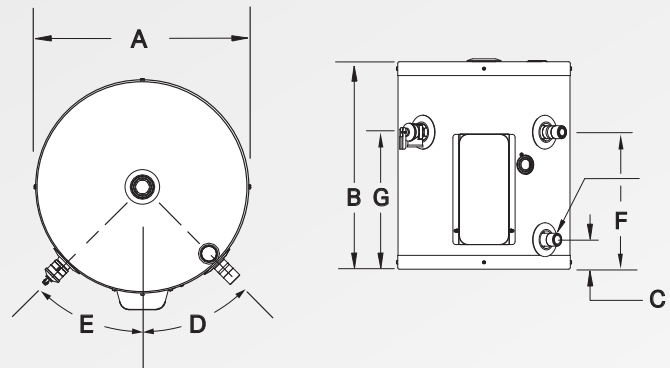

SPECIFICATIONS & DIMENSIONS

Models	Storage capacity			Factory installed wattages						Standby Loss Watts	Diameter (A)		Height (B)		C		D	E	F		G	Estimated ship. weight		
				120V		208V		240V			inches	(cm)	inches	(cm)	inches	(cm)			inches	(cm)		inches	(cm)	lb
	US gal.	Liters	IMP gal.	Watts	Amp.	Watts	Amp.	Watts	Amp.	Watts														
103ETE	2.5	10	2	1,500	12.50	-	-	-	-	-	10	(25)	13 3/4	(35)	2	(5)	68.4°	-	15 5/8	(40)	16 1/2	(42)	22	(10)
106SEO	6	23	5	1,500	12.50	2,250	10.8	3,000	12.50	-	14	(36)	16 7/8	(43)	2 5/8	(7)	45°	45°	11 3/8	(29)	10 1/8	(26)	35	(14)
112SEO	12	45	10	1,500	12.50	2,250	10.8	3,000	12.50	-	16	(41)	22 3/8	(57)	2 5/8	(7)	45°	45°	16 5/8	(42)	15 1/4	(39)	52	(24)
119SEO	19	72	16	1,500	12.50	2,250	10.8	3,000	12.50	54	18 1/4	(46)	26 1/2	(67)	2 5/8	(7)	45°	45°	20 5/8	(52)	19 3/8	(49)	65	(30)
130E†	26	100	22	1,500	12.50	2,250	10.8	3,000	12.50	56	18 1/4	(46)	42 1/2	(108)	2 1/4	(6)	58°	-	43 3/4	(111)	-	-	90	(41)

† Model not illustrated

WARRANTY

6 years

against inner tank leakage

1 year

on component parts

Giant offers a SIX (6)* year limited warranty against inner tank leakage from the date of installation ONE (1)* year limited warranty on component parts. For more specific warranty details including exceptions, consult the owner's manual that comes with each water heater.

*When installed by a professional.

Giant®

11021, Notre-Dame Street East, Montreal-East, Quebec, Canada, H1B 5H3

Telephone : 514-645-8893 • Toll free : 1-800-363-9354

General fax : 514-640-0969

Customer Service fax : 514-645-8413

giantinc.com